

SAFETY SENSORS

Facility safeguarding

SSP
Safety System Products

Content

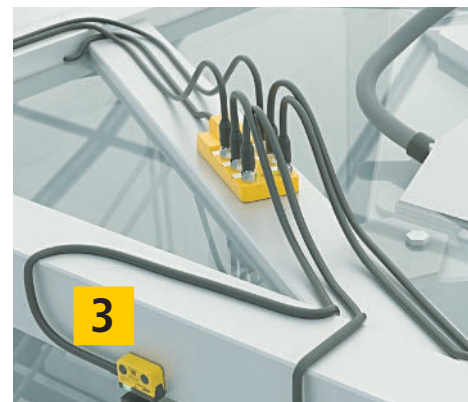
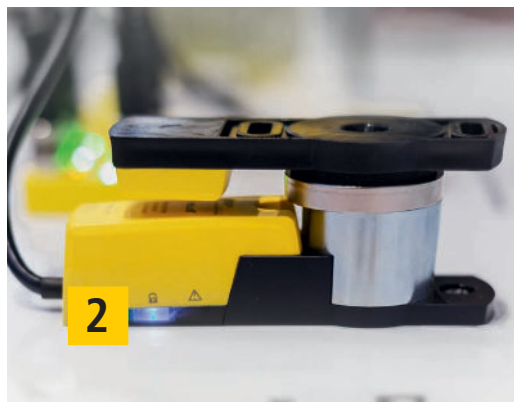

1	RFID Safety Sensors	4
	SAFIX Product Line	4
	Safe Networking	6
	LED Diagnosis	8
	Did you know - EDM	10
	LPZ Product Line	12
	Did you know - Risk time	14
2	HOLDX R RFID Process Lock	16
	PLC Diagnosis	18
	LED Diagnosis	20
	Anchor Plates	22
	Did you know - OSSD outputs	23
	Diagnosis App	24
	Series Connection	28
	Wiring	30
	Did you know - Series connection	32
3	Passive Junction	36
	XCONN Product Line	36
	Product Line Simplifier Wireless Distributor	38



Implementation of safety solutions is often unnecessarily complicated.

At SSP we think differently – We want to make the safety technology applications again as simple as possible and have committed ourselves to the **we wimplify safety** mission.

However, to modify or improve existing products is not enough. **We define safety in a new way.** In the form of a comprehensive, coordinated product range, which offers everything from a single source. From safety fences and sensors to control technology and safety services. In order to achieve this aim, a dynamic team of engineers and technicians works daily on developing products and solutions.

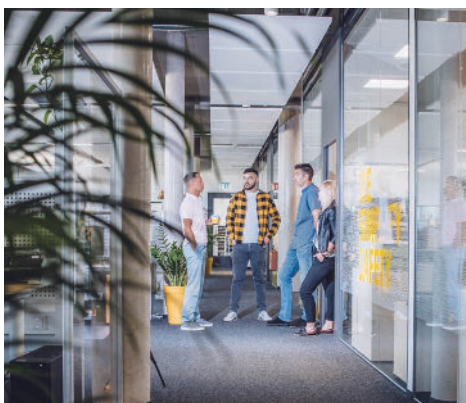

SAFIX Safety Sensor

Compact design

22 mm hole spacing
36 mm width

High protection classes

IP 67 - IP 69K

Connections

5 m line /
10 m line
or pigtail cable M12 8-pin

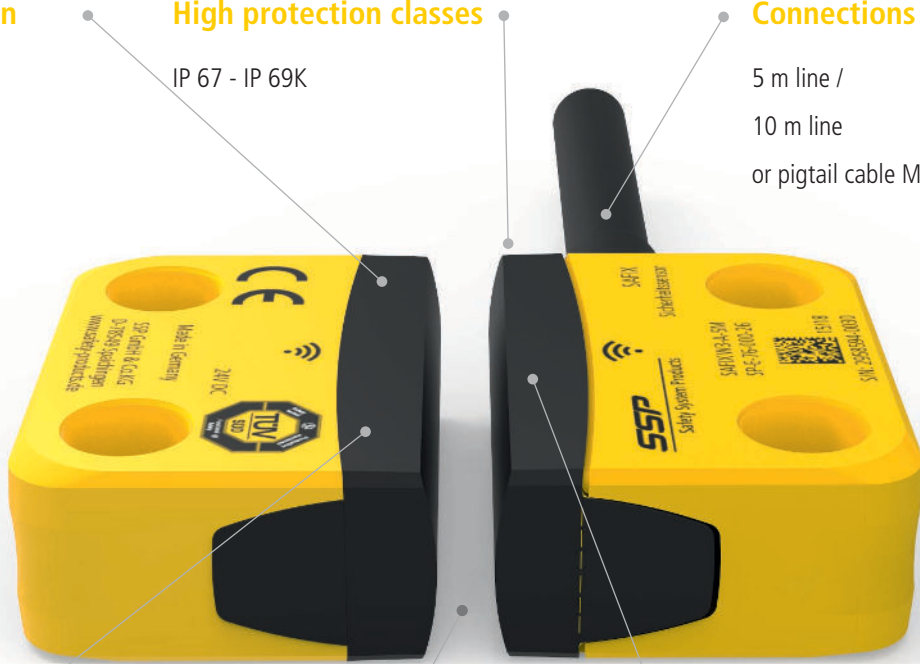

Technology

State-of-the-art RFID sensors

Operating distance

12 mm, can also be
approached from the side

Extended LED diagnosis

On both sides

ECOLAB

IP69K

Intelligent and safe door monitoring

Non-contact RFID safety sensors are used whenever it is possible to open a door at any time. However, the prerequisite for this is that the system quickly comes to a standstill or that the required safety distance can be maintained. Therefore, short risk times and a fast and flexible wiring concept are often one of the most important requirements. In this case, the SAFIX with its short risk time of only 75 ms and its series connection can significantly simplify the planning of a plant.



Risk time and danger zones?

**RISK TIME
75 ms**



SAFIX 3 sensors with XCONN passive junction

Wide range of safety applications

- ✓ PLe acc. to EN ISO 13849-1:2015
- ✓ High coded acc. to EN ISO 14119:2013
- ✓ Series connection of up to 30 sensors without loss of safety
- ✓ Risk time of only 75 ms
- ✓ Integrated EDM function with manual or automatic reset (no safety relay necessary)

Flexible in assembly and wiring

- ✓ High protection classes IP67 and IP69K for use in harsh environments, ECOLAB approval
- ✓ Flexible wiring concept with the XCONN passive junction or wireless-distributor
- ✓ Connections via fixed 5 m and 10 m cable or M12 pigtail connector
- ✓ Extended LED diagnosis



Waterproof housing IP 67 and IP 69K



Resistant to cleaning agents



Flat actuator SAFIX T6

Safe Networking

Safely evaluate and network RFID sensors with the Simplifier Wireless Distributor

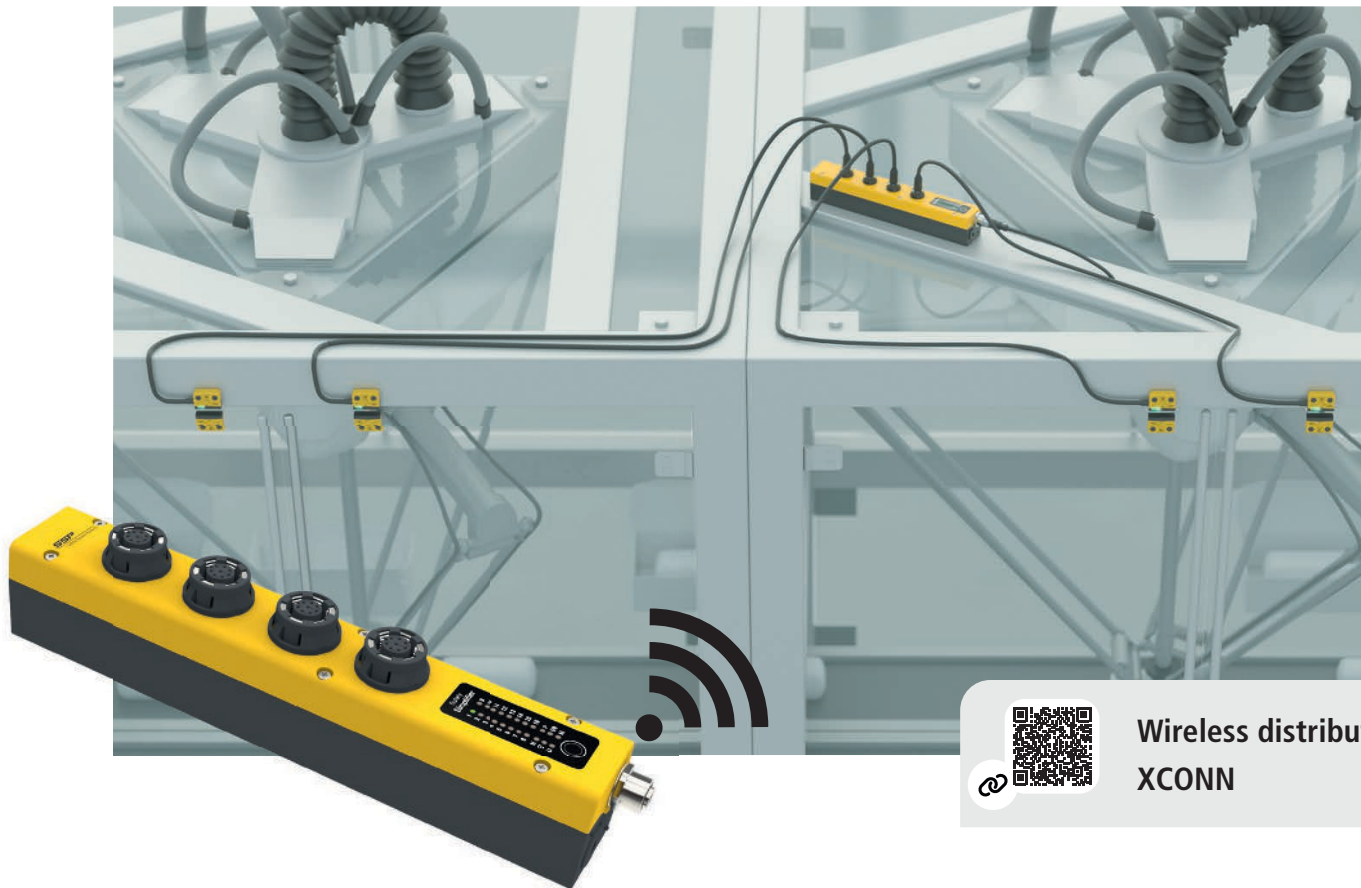

Wireless distributor
XCONN

Connection diagram

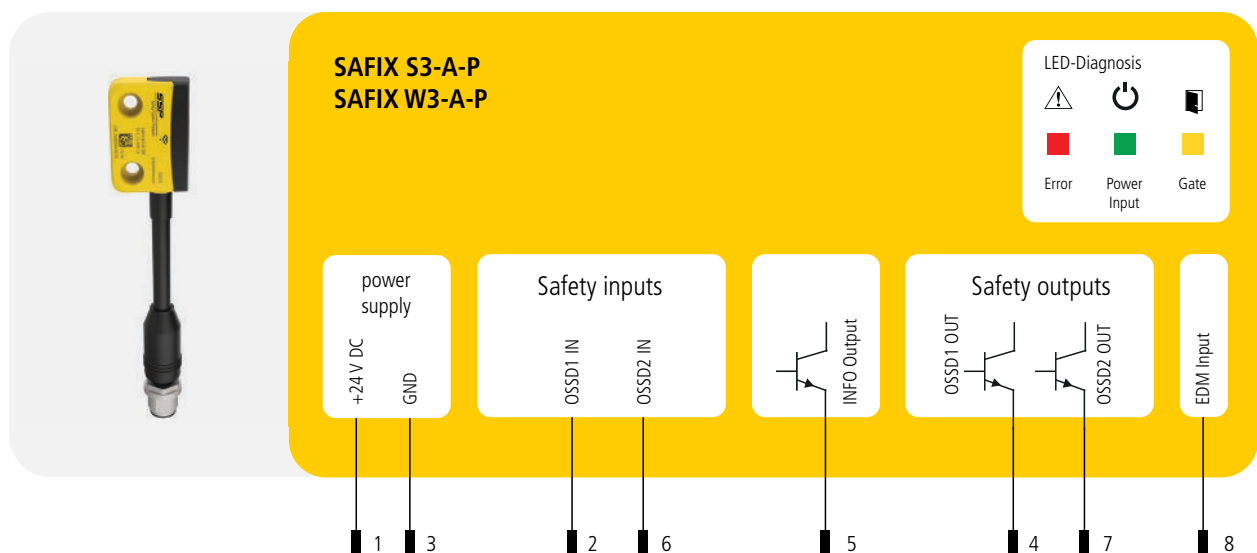



EXTRACT FROM EN ISO 14119:2013

5.2 Arrangement and installation of position switches

Position switches must be arranged in such a way that they are adequately protected against any change in their position. To achieve this, the following requirements must be met:

- a) the fastening elements of the position switches must be reliable and a tool must be required to loosen them.



Risk assessment

If it is stated in the risk assessment that the safety switch must be prevented from loosening (EN ISO 14119:2013), the screw covers supplied are a possibility to omit the safety screws. For subsequent opening of the screws, the cover must be opened with a special tool.

Connection diagram

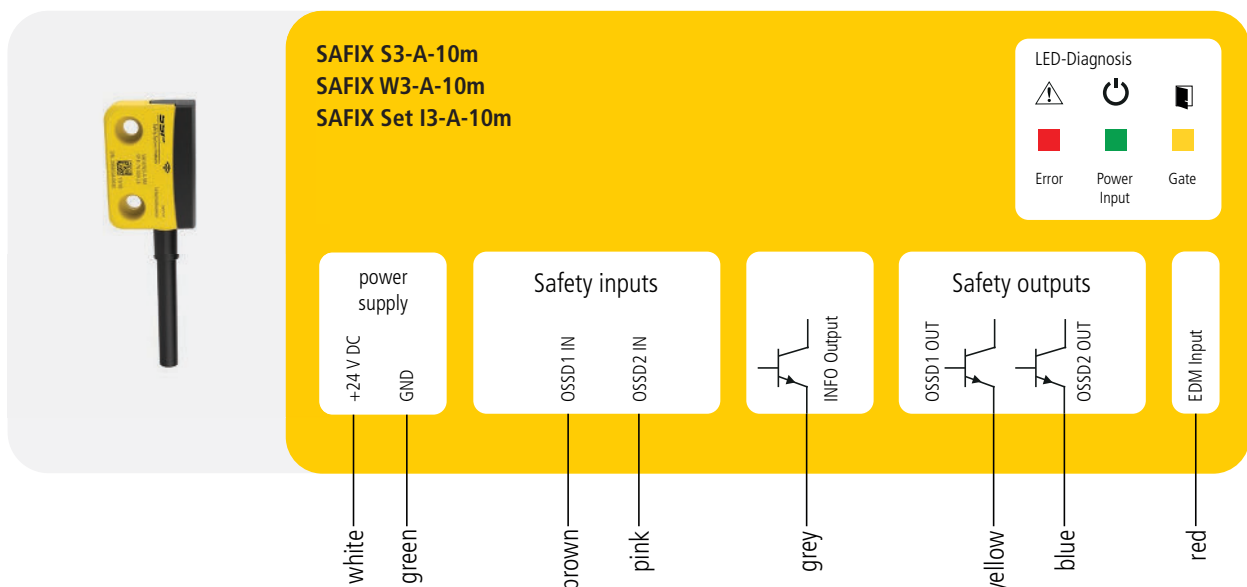

SAFIX Diagnosis

Extended LED diagnosis

Green	Red	Yellow	Remark
off	off	on	Sensor not actuated, voltage applied
on	off	off	Sensor actuated, all inputs set correctly
flashes	off	off	Sensor actuated, safety inputs not set (low level)
flashes	off	off	Safety inputs set (high level), waiting for start pulse
off	off	flashes	Actuator at the reception limit
off	off	flashes	Teach-in process

Green	Red	Yellow	Remark
off	flashes	off	error safety outputs
off	flashes	off	error safety inputs
off	flashes	off	Error safety inputs. EDM automatic: Safety relay fault. EDM manual: Faulty start impulse
off	flashes	off	Overvoltage or undervoltage fault
off	flashes	off	Temperature outside the permitted range
off	flashes	off	Wrong actuator
off	on	off	Permanent light
off	flashes	off	Internal device error

Advantages of the extended diagnosis

- ✓ Reduced machine downtime thanks to LED diagnostic function
 - Door open / closed
 - Error in input / output circuit
 - Series connection diagnosis, whether a door in the series has been opened
- ✓ Diagnostic output for visualization on the standard PLC
 - Door open / closed

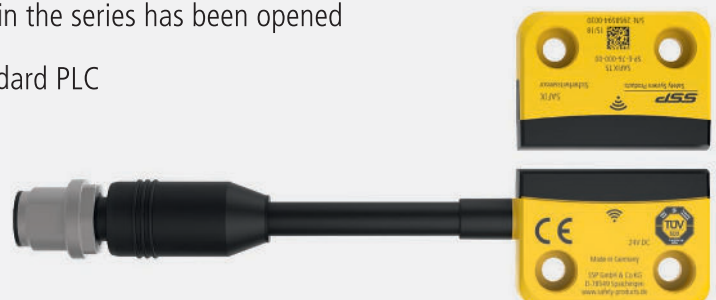

SAFIX 3 connection example with the SSP safety relay S2 series

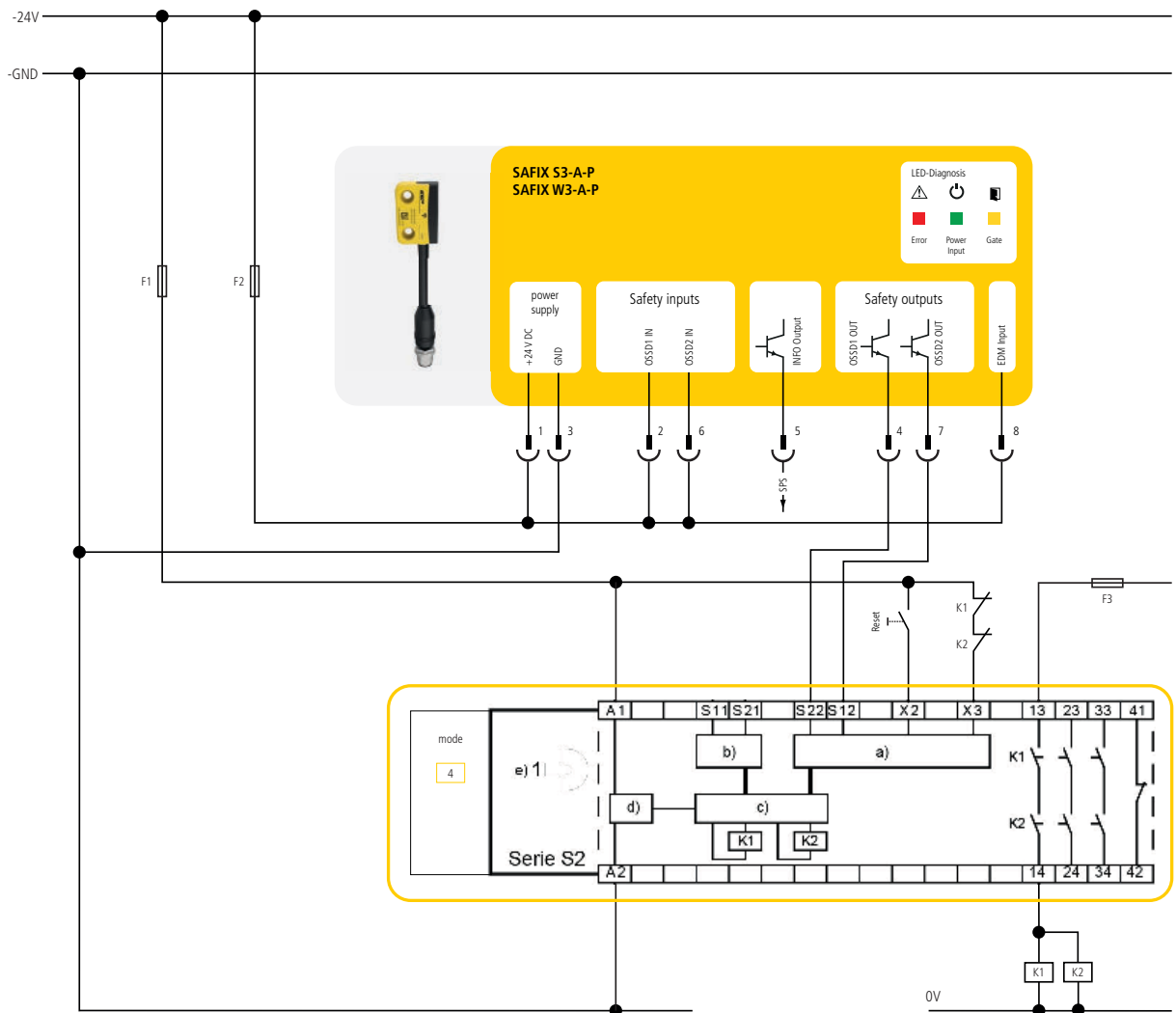

Dimensioning

Sensor

Standard actuator T5

Flat actuator T6

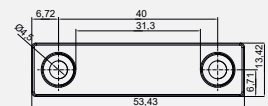
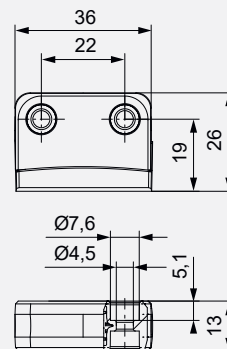
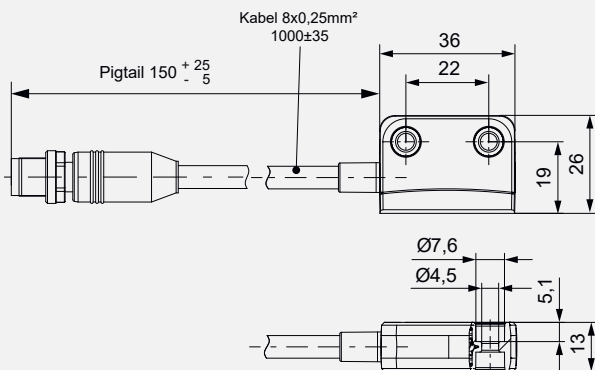

DID YOU KNOW...



... what EDM stands for?

EDM stands for "External Device Monitoring" (feedback circuit). The safety relay monitors the feedback circuits of externally connected contactors with positively driven contacts. The signal at the EDM input is compared with the status of the safety outputs.

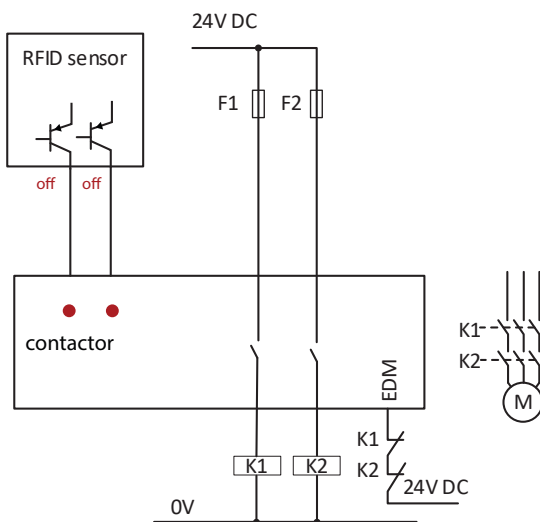

Figure 1:

Safety sensor has shut down,
Contactor are switched off, motor is off,
24 V is available at the EDM input

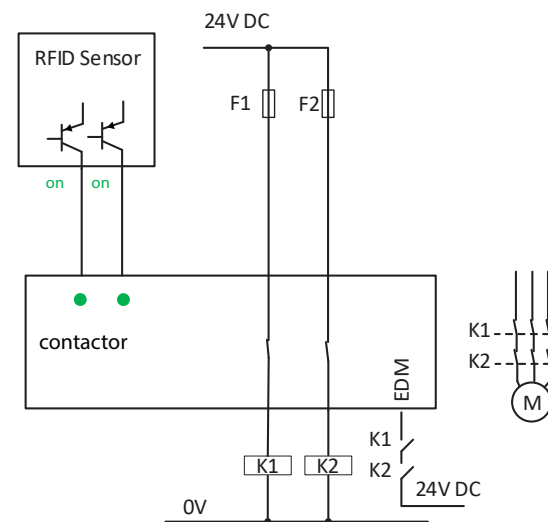

Figure 2:

Safety sensor is switched on,
Contactors are switched on, motor running,
no voltage present at the EDM input

When the safety output is switched on, the feedback circuit is open and when the safety output is switched off, the EDM input 24 V is connected. The NC contacts of the contactors with positively driven contacts are used to check whether the contactors have reached their safe state before they are actuated again. If a safety relay with manual reset function is used, the reset button is connected in series with the feedback circuit contacts.

... that the SAFIX 3 safety sensor already has the EDM function integrated?

The SAFIX 3 safety RFID sensor and the HOLDX R smart process lock have not only implemented state-of-the-art RFID technology, but also the full function of a safety switch device with EDM function. The SAFIX 3 / HOLDX R sensor can optionally be ordered with a manual or automatic reset function. Downstream contactors up to a current consumption of 500 mA can be connected directly to the safe OSSD outputs on the sensor. EDM- input monitors the externally connected contactors with positively driven contacts.

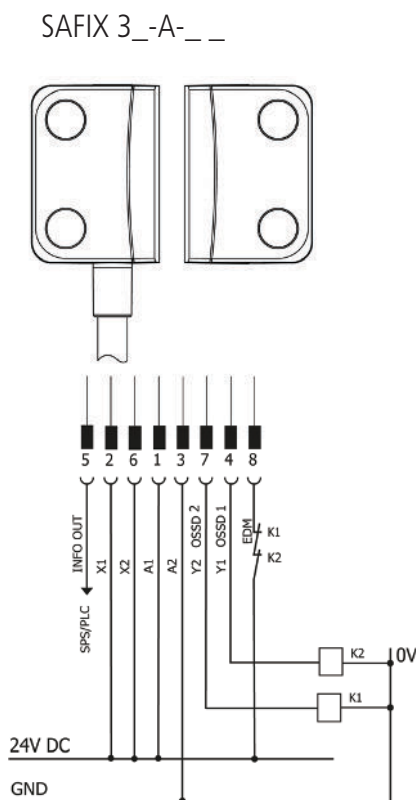

Figure 3:

EDM function with automatic reset button

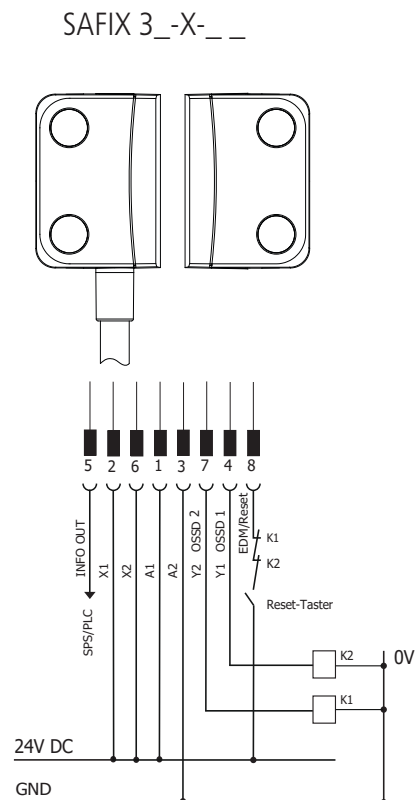

Figure 4:

EDM function with manual reset button

LPZ Safety Sensor

Extended LED diagnosis

On both sides

Operating distance

12 mm

Technology

State-of-the-art RFID sensor technology

Connections



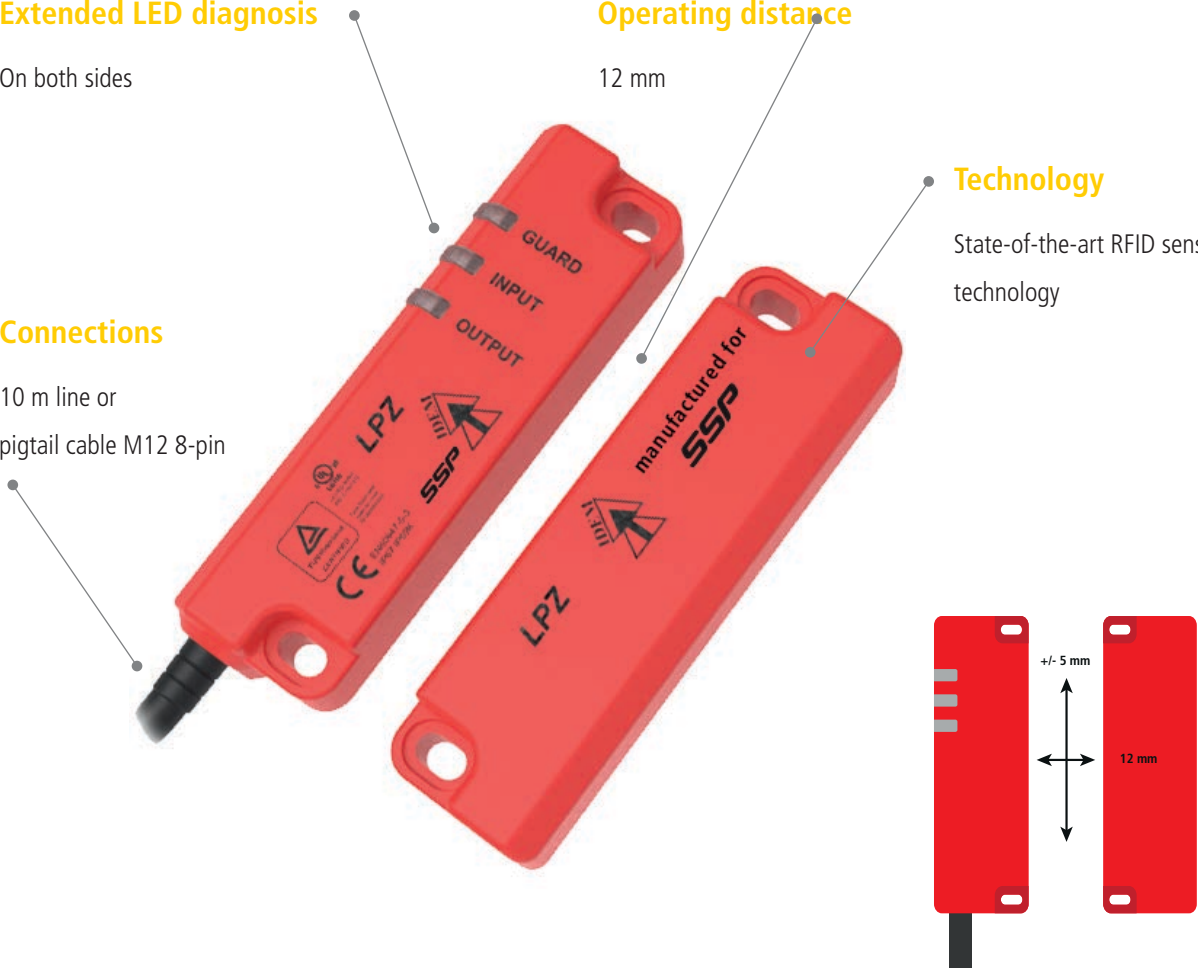

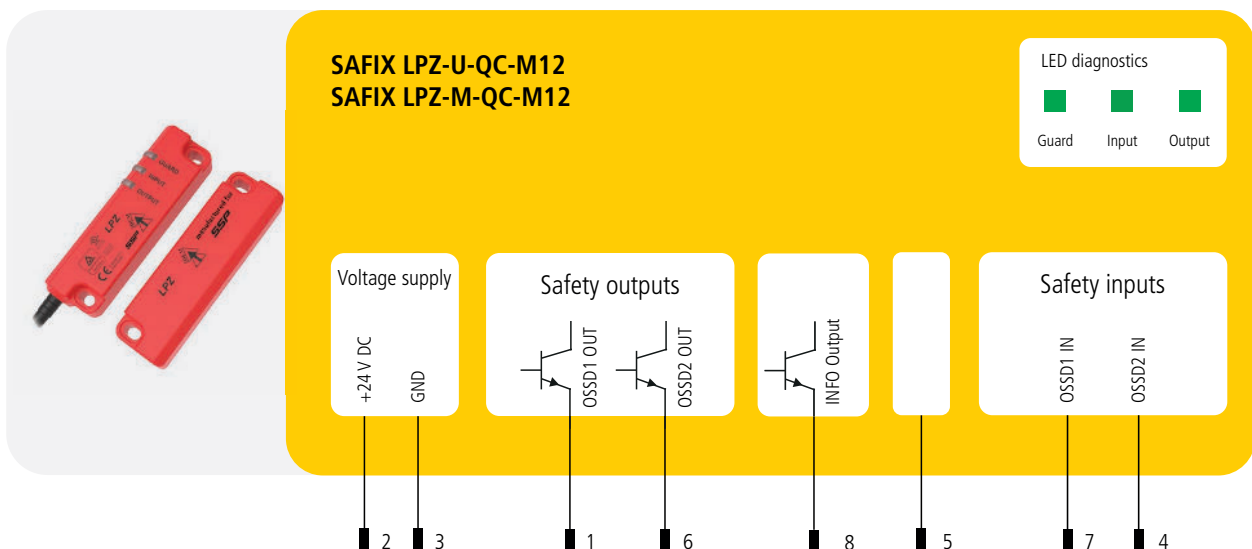

10 m line or pigtail cable M12 8-pin

















Connection diagram



Extended LED diagnosis

Green	Red	GUARD LED
on 	off 	door closed
off 	flashes 	Wrong actuator
off 	on 	door opened

Green	Red	INPUT LED
on 	off 	Safety inputs set
flashes 	off 	Safety inputs missing
off 	off 	Safety inputs not set
off 	on 	Internal error

Green	Red	OUTPUT LED
on 	off 	Safety outputs set
flashes 	off 	Safety outputs missing
off 	flashes 	External error

- Risk time of only 60 ms
- Typical operating distance 12 mm
- High installation tolerance of +/- 5 mm from each side
- Assured operating distance S_{ao} 8 mm
- Assured operating distance S_{ar} 20 mm
- IP69K for the cable version

Connection diagram

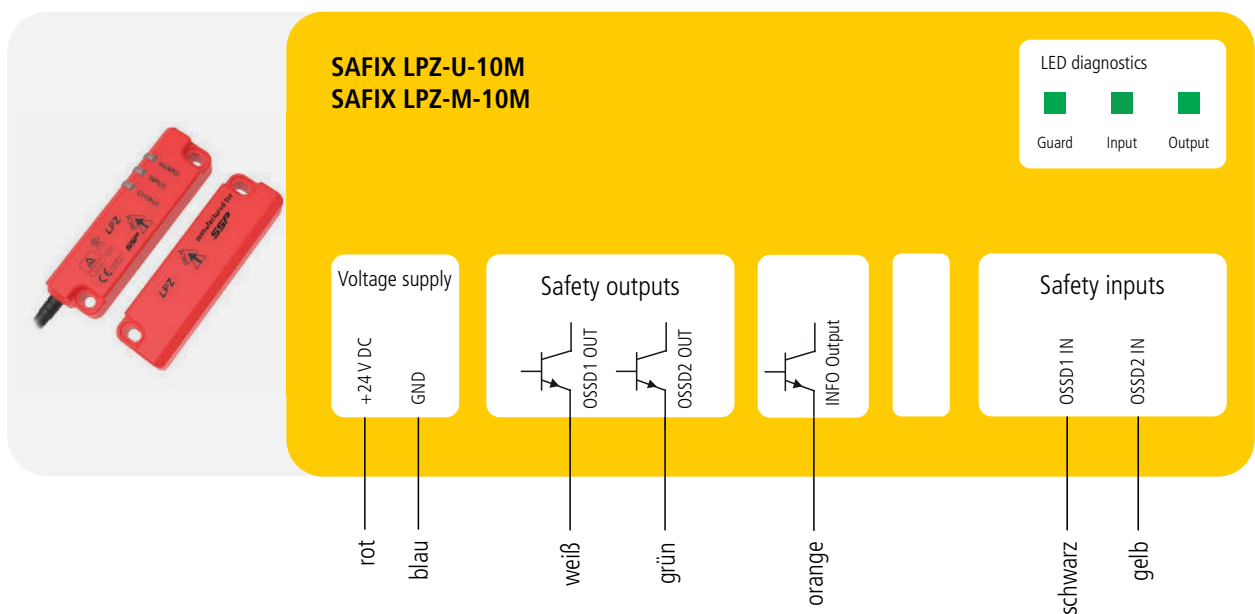

DID YOU KNOW...



... how important fast risk times of RFID sensors are and how does the risk time affect the distance to the danger point?

The standard EN ISO 13855:2010 describes the arrangement of protective devices with regard to the approach speed of human bodies. The minimum distance of a guard without guard locking to the first dangerous movement is therefore calculated as shown in the following diagram.



$$S = K \cdot T$$

S = Distance to danger point

K = Constant = 1600 mm/s

T = Total time to standstill



In the following calculations we would like to show you an example of how the risk time of RFID safety sensors can affect the distance to the danger point (without series connection).

<p>Example RFID safety sensor SAFIX 3 or process lock HOLDX R</p> <p>Switch-off delay (toff) actuator to OSSD output: max. 75 ms</p>	<p>process lock</p> <p>Switch-off delay (toff) actuator to OSSD output: max. 260 ms</p>
<p>$S = 1600 \text{ mm/s} \cdot 75 \text{ ms}$ $S = 120 \text{ mm}$</p>	<p>$S = 1600 \text{ mm/s} \cdot 260 \text{ ms}$ $S = 416 \text{ mm}$</p>
<p>The risk time of 75 ms alone results in a safety distance of 120 mm. For very precise calculation, you must add the risk time of the evaluation unit (e.g. safety controller) and the overrun to standstill.</p> <p>Example of standard RFID safety sensor or</p>	<p>The calculation shows that by using a risk time of 260 ms, a safety distance of 412 mm is already maintained. This is 292 mm more than in the previous calculation. This can be an important factor for the design of a machine.</p>



If safety sensors are connected in series, the risk time of switching off the inputs must also be taken into account in the calculation. In the following example, 24 sensors are connected in series.

<p>Example RFID safety sensor SAFIX 3 or process lock HOLDX R</p> <p>1 x Switch-off delay (toff) actuator to OSSD output: max. 75 ms</p> <p>23 x switch-off delay (toff) inputs max. 3 ms</p>	<p>Example of standard RFID safety sensors or process locks</p> <p>1 x Switch-off delay (toff) actuator to OSSD output: max. 260 ms.</p> <p>23 x switch-off delay (toff) inputs max. 20 ms</p>
<p>$T = 75 \text{ ms} + 23 \cdot 3 \text{ ms}$ $T = 144 \text{ ms}$</p> <p>$S = 1600 \text{ mm/s} \cdot 144 \text{ ms}$ $S = 230.4 \text{ mm}$</p>	<p>$T = 260 \text{ ms} + 23 \cdot 20 \text{ ms}$ $T = 720 \text{ ms}$</p> <p>$S = 1600 \text{ mm/s} \cdot 720 \text{ ms}$ $S = 1152 \text{ mm}$</p>
<p>For for exact calculation, you must also add the risk time of the evaluation unit (e.g. safety controller) and the overrun to standstill.</p>	

HOLDX R

INDUSTRY
4.0

The Smart Process Lock HOLDX R

Protecting processes and humans

The smart HOLDX R process lock protects packaging systems from unintentional opening. The integrated RFID safety sensor ensures the safety of the system, while the electromagnet keeps the door closed and thus protects automated processes. The integrated RFID safety sensor meets the highest performance level PLe according to EN ISO 13849-1:2015. An integrated Bluetooth interface and extended LED diagnosis enable smart operation and fast evaluation. With the variants RS (small, 600 N locking force) and RL (large, 1200 N locking force), two variants are available for a wide range of applications.

Two designs for maximum flexibility



HOLDX RS

In its small and compact design, the HOLDX RS enables a locking force of 600 N. In addition to the locking force of the electromagnet, the movably supported anchor plate has a 50 N permanent magnet which prevents a door from instant opening.



HOLDX RL

Ideal for large doors. Thanks to the locking force of 1200 N the HOLDX RL prevents doors from tearing open. With a slim width of only 35 mm, the guard locking is ideal for space-saving installation on aluminum profile systems. Like the HOLDX RS, the guard locking has also has a permanent magnet of 50 N, which prevents a door from opening.



Simple installation, reduced commissioning time

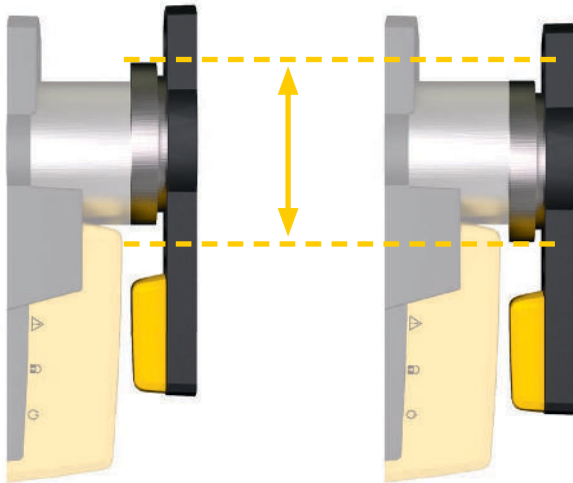

Flexible door offset

Through the combination of RFID technology and a modern electromagnet, HOLDX R allows a large tolerance in door offset and thus significantly increases machine availability even with inaccurate door guidance.

Simplified application

- ✓ Reduced commissioning time thanks to flexible assembly concept on aluminum systems
- ✓ Pigtail connection reduces cable diversity (straight and angled cables)
- ✓ Reduced machine downtime thanks to diagnostic function

Quick installation

- ✓ 600 N locking force for small flaps
- ✓ 1200 N locking force for heavy doors
- ✓ 50 N permanent latching force (optional)
- ✓ Flexible adjustment of latching force from 0-50 N via free app or desktop software
- ✓ Integrated magnetic flux measurement for contamination diagnosis



Extended PLC Diagnosis



Only 1 input for the diagnosis function with more than 30 status information.

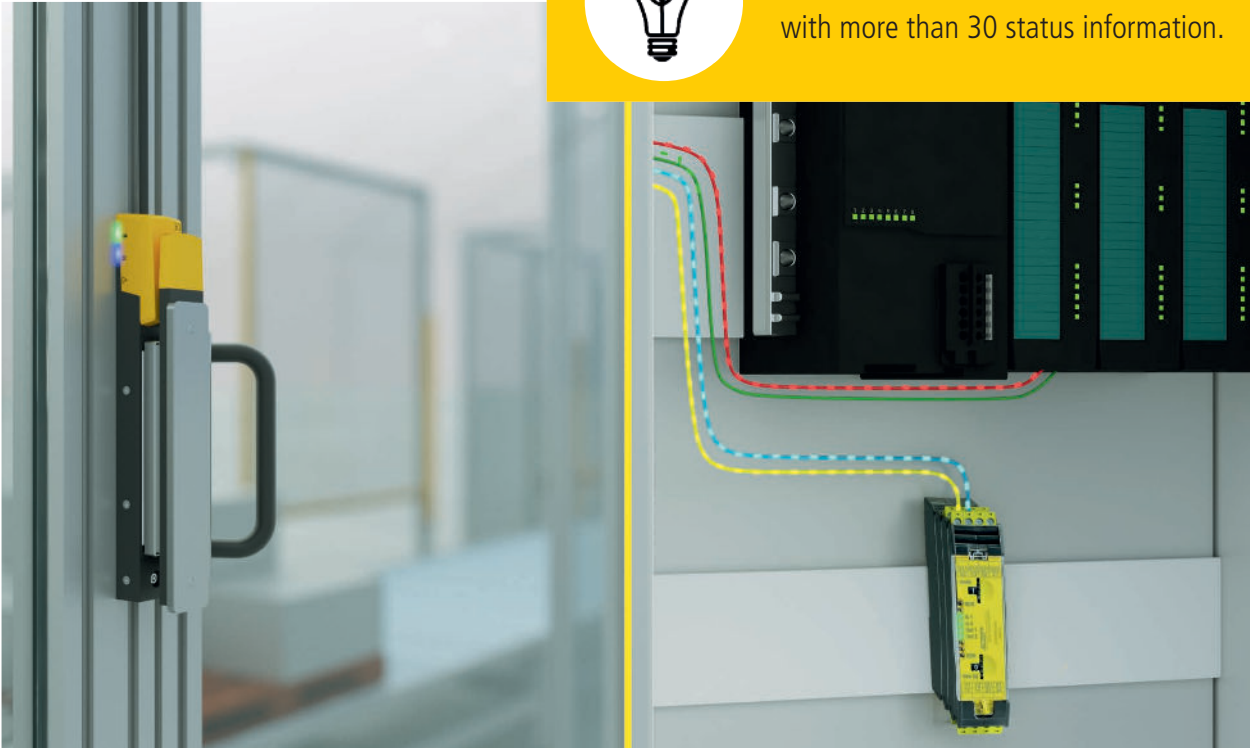

Diagnosis on machines and plants is becoming increasingly important; downtime due to wear or defective components costs a lot of money. Service activities around the world often cause unnecessary costs and require technical personnel - these personnel are occupied and not available elsewhere.

The smart HOLDX process lock is a unique new approach. With only one standard input at your higher-level PLC, you get a full diagnosis spectrum. The HOLDX reports information to you, such as:

- ✓ Short circuits in the output circuit
- ✓ Line interruptions in the input circuit
- ✓ Under- or over-voltages
- ✓ Too high temperature
- ✓ Contamination of the guard locking
- ✓ Manipulation (wrong RFID tag)
- ✓ Status messages Door open or closed
- ✓ Guard locking ACTIVE

Ready-to-use Functional Modules

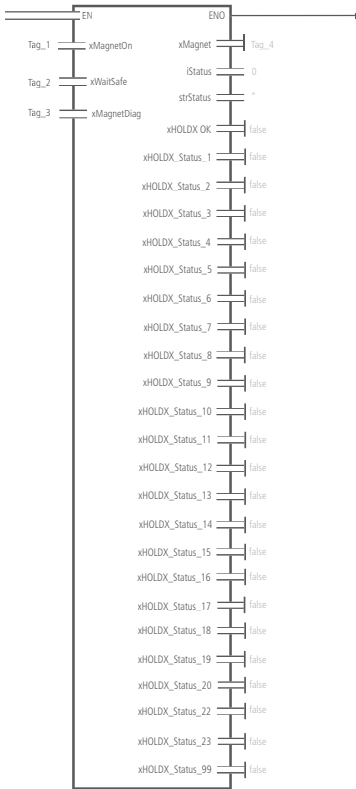

In line with the SSP vision "we simplify safety", ready-to-use functional modules for the higher-level PLC are available for download from the website. Not only do you get the diagnosis output, but you also get direct plain text messages to your HMI for each condition.



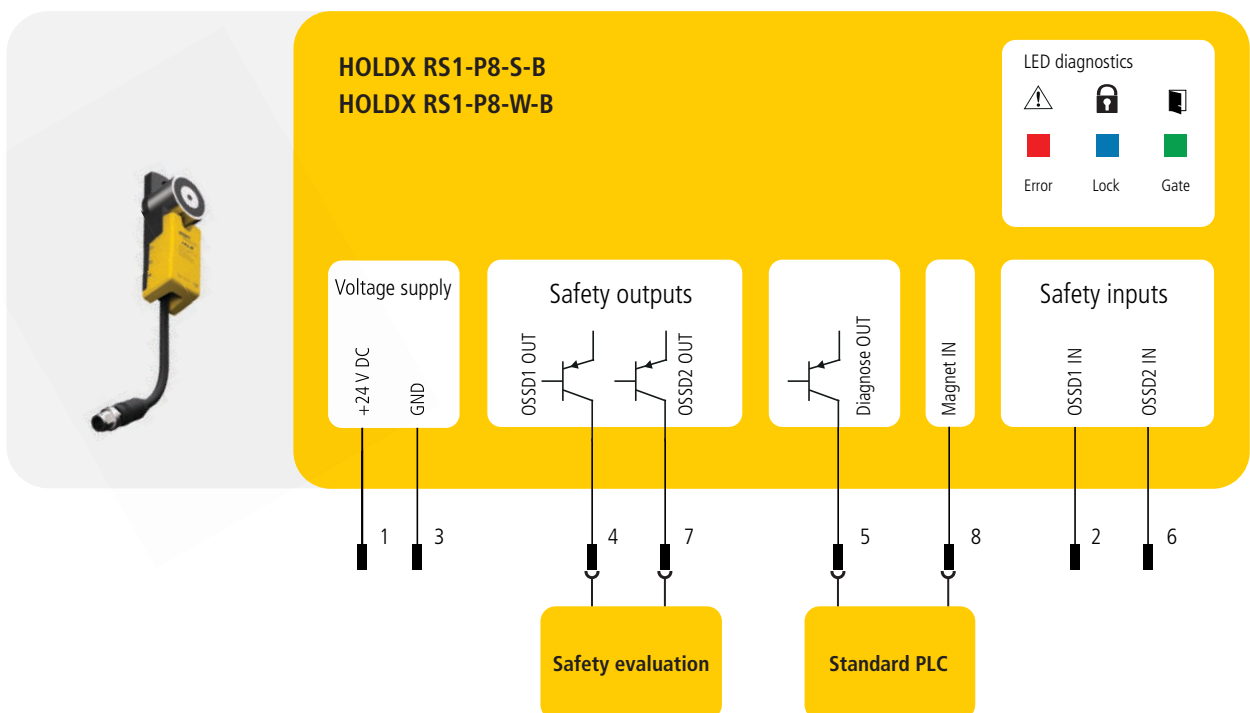

Siemens, Rockwell,
Beckhoff, B&R, Codesys

Connection of the HOLDX to the standard PLC for diagnosis



HOLDX R

Extended LED Diagnosis

Green	Safe sensor function
on	OSSD input circuit available, door closed
flashes 	door opened
flashes 	OSSD input circuit not available, door closed
flashes 	OSSD input circuit not available, door opened

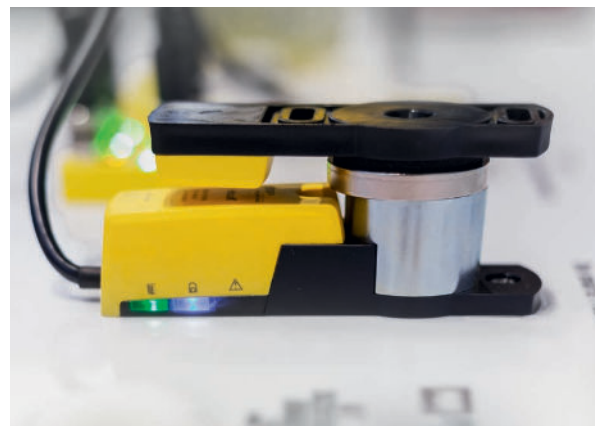

The smart HOLDX R process lock enables simple and fast diagnostics thanks to LEDs on both sides. It immediately detects if another process lock in the system does not achieve the desired locking force or if there is a fault in the input or output circuit of the guard locking. In this way, the system or guard locking can be cleaned or realigned completely in line with the preventive maintenance of the system.

Connection diagram

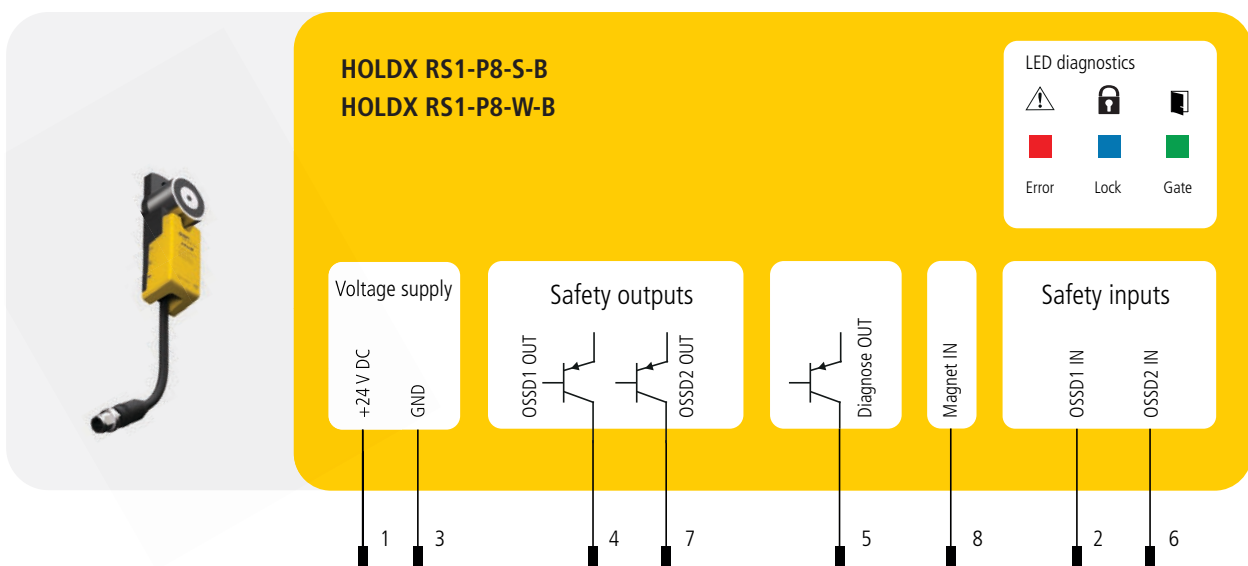



Extended LED diagnosis

Green	Red	Blue	System states
on 	on 	on 	device start
flashes 	flashes 	flashes 	teach-in process RFID
flashes 	flashes 	flashes 	Device pinged
flashes 	-	flashes 	Calibration of the magnets required

Blue	Guard locking function
off 	magnet not actuated
on 	door closed, Locking force available
flashes 	door closed, locking force not reached
flashes 	Door opened, Magnet actuated
flashes 	Magnet is being calibrated (fast flashing)

Red	Fault diagnosis
off 	No error present
on 	Internal device error
flashes 	error safety outputs
flashes 	error safety inputs
flashes 	overvoltage or undervoltage
flashes 	error door torn opened
flashes 	Temperature outside the permitted range
flashes 	Wrong RFID actuator
flashes 	Error magnetic flux measurement
flashes 	Set B10 ₀ values in limit range
flashes 	RFID sync error

Connection diagram

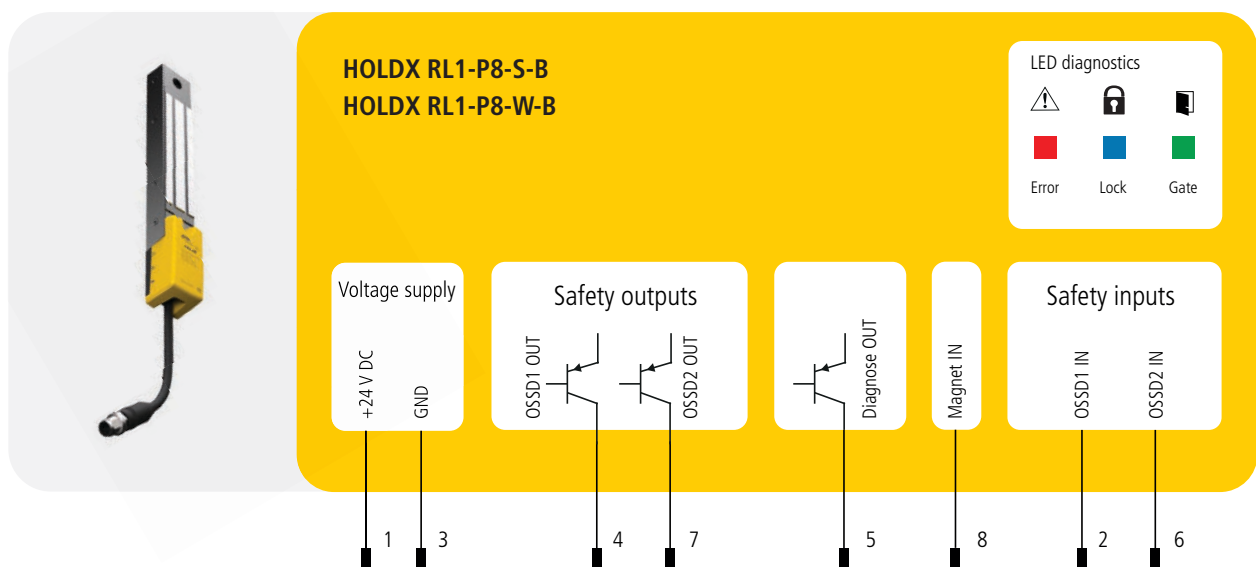

Flexible Anchor Plates

Two variants can be selected, with or without permanent magnet for both sizes.

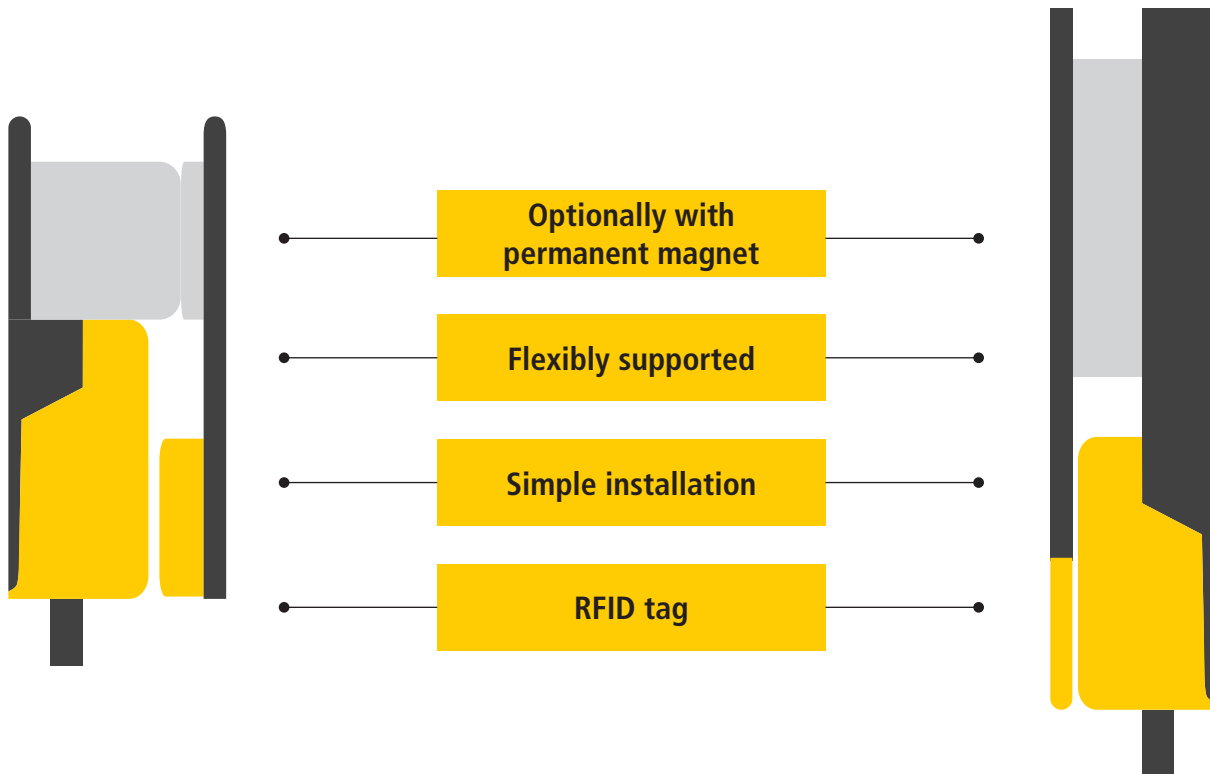

HOLDX RS-A1 with 50 N permanent magnet
 HOLDX RS-A2 without 50 N permanent magnet

HOLDX RL-A1 with 50 N permanent magnet
 HOLDX RL-A2 without 50 N permanent magnet

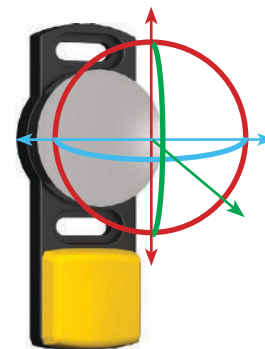

Movable anchor plate

DID YOU KNOW...



... how OSSD outputs work?

OSSD means "Output Switching Signal Device". This output type is typically used with safety sensors and safety light curtains or for safe control outputs. Conventional 24 V DC outputs are actually critical for safety functions, as they cannot be detected by an external 24 V line via a short circuit. For this reason, the two OSSD outputs are switched off with a time delay. During the pause time of the output, a built-in input is activated and read back. If 24 V is present at the input after switching off the output, an error is detected and the two built-in processors safely switch off both outputs.

This technology makes it easy to monitor short circuits and cross circuits up to PLe according to EN ISO 13849-1:2015. With the aid of an extended LED diagnosis, such as on the HOLDX R process lock or the RFID safety sensors of the SAFIX, the detected faults on the safety sensor can be quickly identified, making troubleshooting much easier.

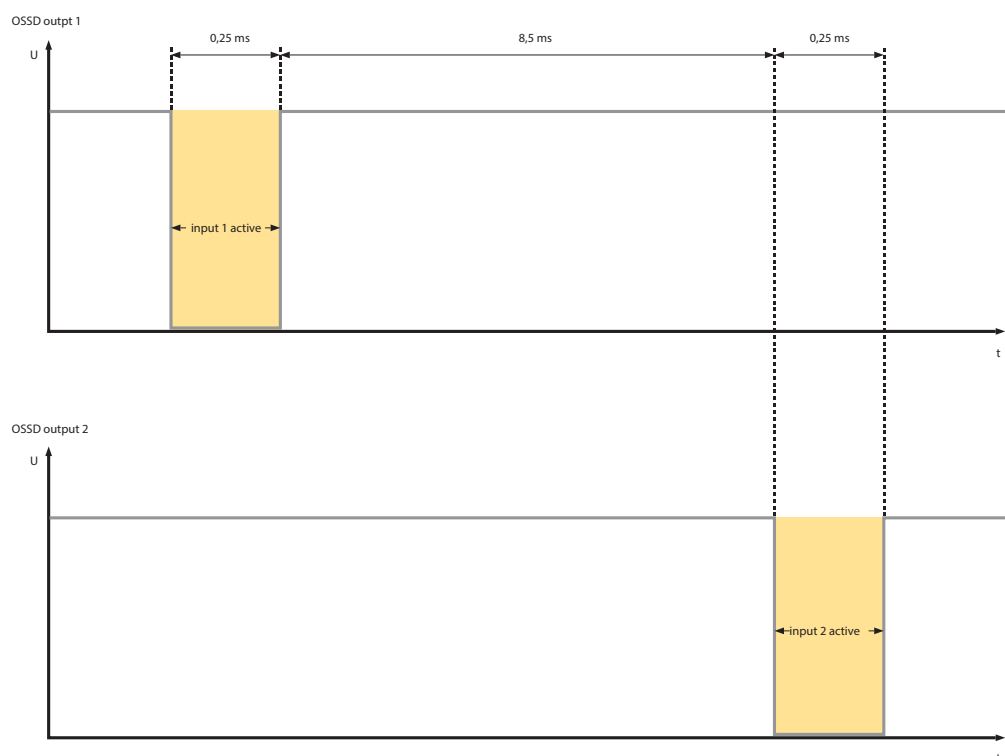
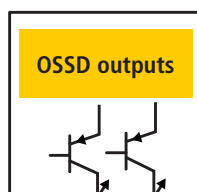
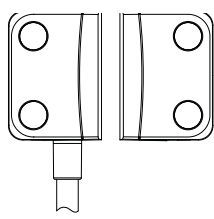

Time course of input and output functions

Free Software



Contemporary mobile security technology.
Smartphone compatible.



Download HOLDX Manager for
Apple, Android and Microsoft

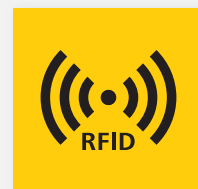

Manipulation monitoring

Quick traceability:
Frequency of actuators that have been
taught in again is documented.

HOLDX Manager

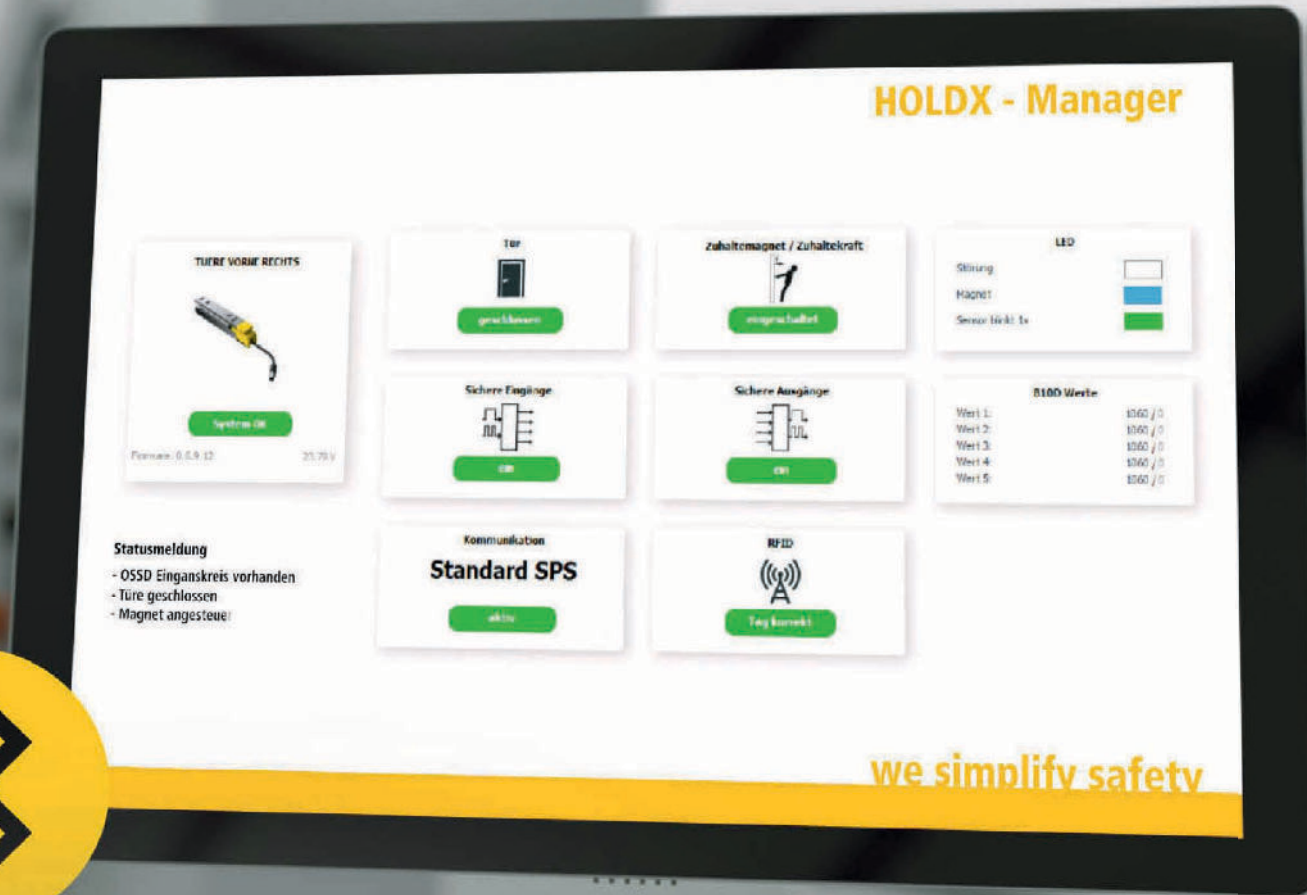

Quick troubleshooting

Direct diagnostics in the circuit diagram for fast maintenance and troubleshooting.

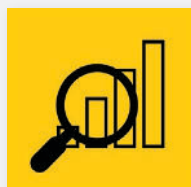

Error history

Documented fault history for sustainable servicing.

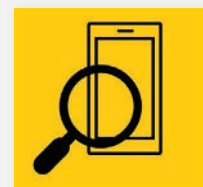

Mobile diagnosis

Comfortably search for errors on your desktop or save time with your smartphone. Sophisticated measuring devices are not necessary.

Software Surface

You receive all status messages of the smart HOLDX process interlock in one view.

The software surface displays the following components:

- No Device Name:** Firmware: 0.9.10.71, 24.12.17, System OK
- Tür:** geschlossen
- Zuhaltmagnet / Zuhaltkraft:** Freigeschaltet
- LED:** Steuerung, Magnet, Sensor
- Diagnosedaten:** (highlighted)
- Sichere Eingänge:** Ein
- Sichere Ausgänge:** Ein
- B100 Werte:**

B1001-Description	202 / 0
B1002-Description	202 / 0
B1003-Description	202 / 0
B1004-Description	202 / 0
B1005-Description	202 / 0
- Verschmutzungswert:** 100%
- Statusmeldung:**
 - OSD Eingangsstatus vorhanden
 - Tür geschlossen
 - Magnet eingeschaltet
- Kommunikation Standard SPS:** aktiv
- RFID:** Tag korrekt
- Standalone:**

Direct and fast fault diagnosis

The software surface displays the following components:

- No Device Name:** Firmware: 0.9.10.20, 23.02.17, Fehler
- Tür:** geschlossen
- Zuhaltmagnet / Zuhaltkraft:** Ausgeschaltet
- LED:** Steuerung blinkt bl, Magnet, Sensor
- Diagnosedaten:**
- Sichere Eingänge:** Ein
- Sichere Ausgänge:** (highlighted) Fehler
- B100 Werte:**

B1001-Description	03 / 0
B1002-Description	03 / 0
B1003-Description	03 / 0
B1004-Description	03 / 0
B1005-Description	03 / 0
- Verschmutzungswert:** -
- Statusmeldung:** Fehler RFID Betätigt
- Kommunikation Standard SPS:** aktiv
- RFID:** Tag korrekt
- Master:**

Status information about the RFID tag

The software surface displays the following components:

- No Device Name:** Firmware: 0.9.10.20, 03.03.17, Fehler
- Tür:** geöffnet
- Zuhaltmagnet / Zuhaltkraft:** Ausgeschaltet
- LED:** Steuerung blinkt bl, Magnet, Sensor
- Diagnosedaten:**
- Sichere Eingänge:** Ein
- Sichere Ausgänge:** Aus
- B100 Werte:**

B1001-Description	19 / 0
B1002-Description	19 / 0
B1003-Description	19 / 0
B1004-Description	19 / 0
B1005-Description	19 / 0
- Verschmutzungswert:** 100%
- Statusmeldung:** Fehler RFID Betätigt
- Kommunikation Standard SPS:** aktiv
- RFID:** (highlighted) Tag nicht korrekt
- Standalone:**

All current states and the fault history help to plan maintenance and servicing or troubleshooting in a plant.

Gate Monitoring		Error Historie		Diagnosedaten	
Anzahl Türe aufgerissen	2	Error 1: - Fehler Über bzw. Unterspannung		Anzahl Über- bzw. Unterspannung	5
Anzahl Magnet angesteuert	199	Error 2: - Fehler Über bzw. Unterspannung		Anzahl Übertemperatur	0
Anzahl Zuhaltkraft unterschritten	14	Error 3: - Fehler Über bzw. Unterspannung		Anzahl interne Fehler	0
Anzahl falscher RFID Tag	0	Error 4: - Fehler Über bzw. Unterspannung		Anzahl RFID-Sync Fehler	0
Anzahl Fehler am Sicherheitsausgang	19	Error 5: - Fehler Über bzw. Unterspannung		Anzahl UART Fehler	0
Anzahl Fehler am Sicherheitseingang	1	Error 6: - Fehler Sicherheitseingänge			
Anzahl Teachvorgänge	0	Error 7: - Fehler Türe aufgerissen			
		Error 8: - Fehler Türe aufgerissen			
		Error 9: - Fehler Türe aufgerissen			
		Error 10: - Fehler Über bzw. Unterspannung			

The fault can be determined here in the circuit diagram without operating manual: External voltage at outputs PIN 4 and PIN 7. Each error receives a suggested solution for troubleshooting and a status display.

No Bremsname



Fehler

Firmware: 0.8.10.67 23.76 V

Sichere Ausgänge

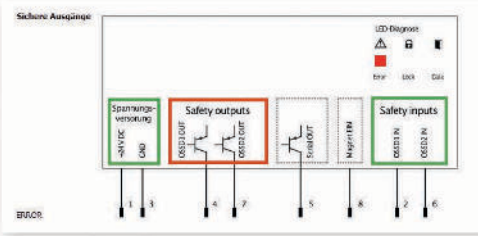

LED Diagnose: ■ ■ ■ ■

ErrF Lock Data

Status

- Fehler Sicherheitsausgänge

Ursache

- Kurzschluss zwischen Sicherheitsausgängen gegen Masse oder gegen +24 V DC
- Drahtbruch

Lösung

- Versorgungsspannung abschalten
- Kurzschluss/Drahtbruch am Ausgang beseitigen
- Versorgungsspannung neu anlegen

At a glance, you can see how often a new actuator has been taught or manipulation attempts have been made.

Slave 2



Fehler

Firmware: 0.8.10.73 24.24 V

RFID

Falscher Tag erkannt: **2**

Neuer Tag geteacht: **0**

Status

- Falscher RFID Betätiger

Ursache

- Falscher Betätiger im Erfassungsbereich des Sensors

Lösung

- Korrekten Betätiger verwenden

HOLDX R2

Smart Series Connection

Packaging machines and assembly plants often have many doors so that easy access to the machine is guaranteed during set-up mode or for maintenance purposes. More than ten doors in a safety circuit are not uncommon. The smart HOLDX R2 process lock was developed for exactly this kind of applications.



The pigtail cables of the HOLDX R2 are designed so that a double leaf door can be mounted without additional connecting cables. The cable ends of the pigtail cables are simply connected together.

Extensive diagnosis

- ✓ Door opened/closed
- ✓ Door locked
- ✓ Dirty or poorly adjusted
- ✓ Manipulation of RFID sensors has taken place (values are stored)
- ✓ Short-circuit in input or output circuit

Advantages in the application

- ✓ High locking force of up to 1200 N
- ✓ PLe acc. to EN ISO 13849-1:2015
- ✓ Series connection – up to 30 guard locking devices without loss of safety
- ✓ No gateway required for diagnosis and communication with the higher-level PLC
- ✓ Single information signals of each HOLDX R2 available
- ✓ Locking force of 600 N or 1200 N, depending on model



Planning, wiring and commissioning easier than ever before

Thanks to an intelligent and simple wiring concept, up to 30 HOLDX R2 can be easily connected in series without giving up the diagnosis options. This allows individual evaluation of each participant without the need for an additional gateway. It is also possible to evaluate the information from the HOLDX R2 on any commercially available control unit. SSP offers ready-to-use functional modules for controllers from Siemens, Beckhoff, Rockwell and B&R. Thus, the HOLDX R2 provides more than 300 pieces of information for diagnosis of the control unit.



Open each door specifically

With the smart HOLDX R2, not only do you get full diagnostics on the door's status, but each door can be enabled individually to turn off the corresponding magnet:

Optimal for double doors, thanks to the flexible pigtail cables.

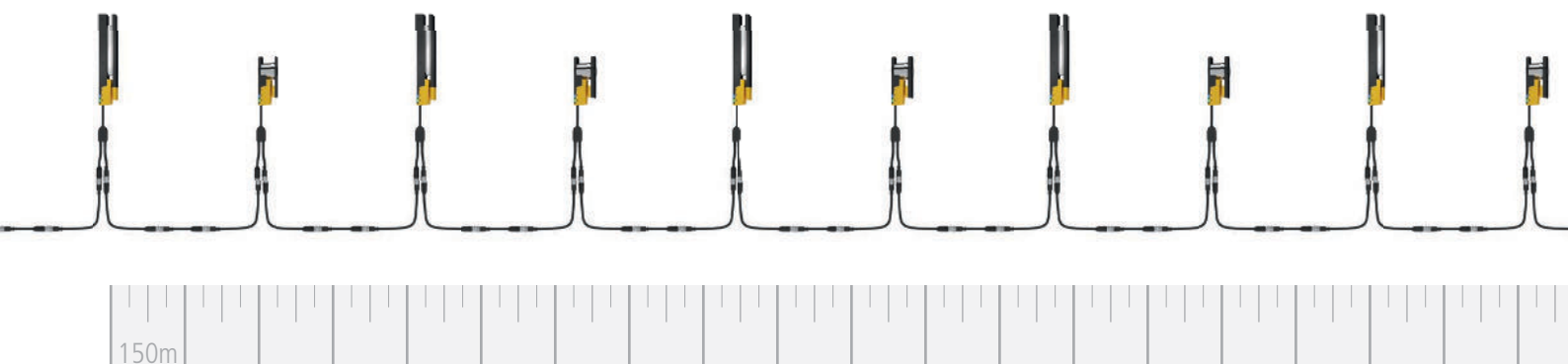

Simple Wiring

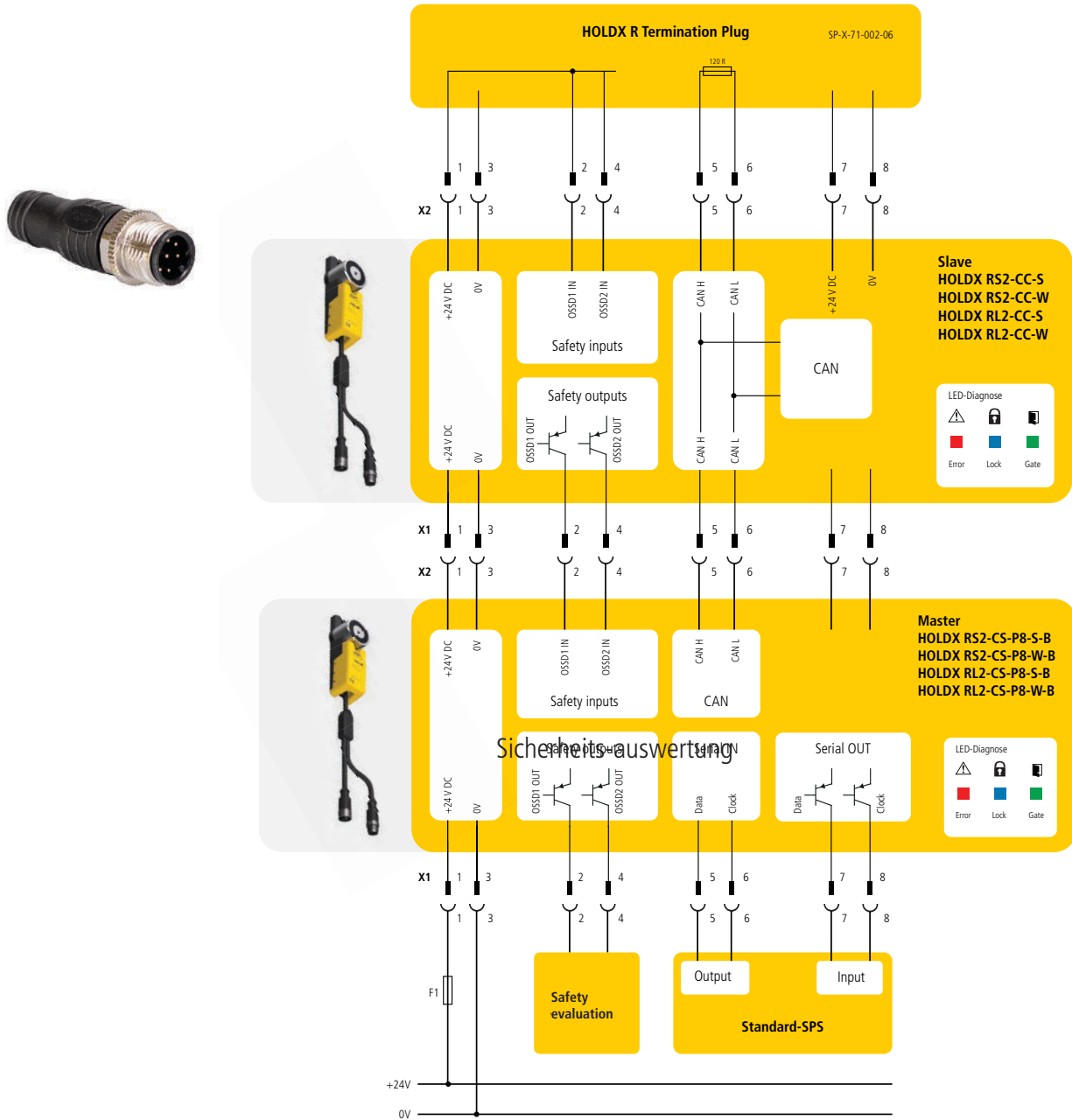

Cable lengths in the system of up to 150 m can be implemented without voltage drop. After approx. 6-8 HOLDX, the voltage supply can be optimized using an external voltage supply.

Thanks to the HOLDX Manager, the system and wiring can be planned in a user-friendly and time-saving way before commissioning.



Intelligent Series Connection

Advantages of intelligent series connection

- ✓ Series connection of up to 30 process locks up to PLe according to EN ISO 13849-1:2015
- ✓ Up to 300 diagnostic information are available in the system with series connection
- ✓ Each process lock can be controlled individually
- ✓ Evaluation of diagnostics on the standard - PLC without gateway
- ✓ Functional modules for Siemens / Beckhoff / Rockwell/ B&R available on the homepage for evaluation of diagnostics

Addressing without laptop & without software

The HOLDX R2 sequence and commissioning is done by opening and closing the door once. The HOLDX Manager guides the user through the learning process of the HOLDX application. The software is purely supportive and is not mandatory.



DID YOU KNOW...



... that the Performance Level (PL) is reduced with a series connection of safety switches with mechanical contacts?

In order to save costs, safety switches of several safety doors are often connected in series to a safety relay. However, the diagnostic capability of the faults is greatly reduced with a series connection of door switches with mechanical contacts. This makes it difficult to determine the achievable performance level. This topic is described in EN ISO 14119:2013 in paragraph "8.6 Logic series connection of interlocking devices" and reference is made to the technical report ISO/TR 24119. In the past, the same degree of diagnostic coverage (DC) was often incorrectly assumed for mechanical safety switches, even with a series connection and a DC of 99% was specified by the manufacturers.

However, in a series connection the actual DC often shrinks below 60% and the achievable performance level of PLe drops to PLc. For this reason, many machines are unnoticed equipped with an inadequate PL and are therefore not safe. According to ISO/TR, these faults are referred to as fault concealment, but EN ISO 13849-1:2015 requires for Cat. 3 or Cat. 4 that every first fault is detected by the system - without impairing the protective function. For this reason, no category 3 can be claimed for these machines and the performance level PLe is not achieved, regardless of whether the DC is above 60%.

Figure 1:

All doors are closed. No error in the safety circuit, motor is running

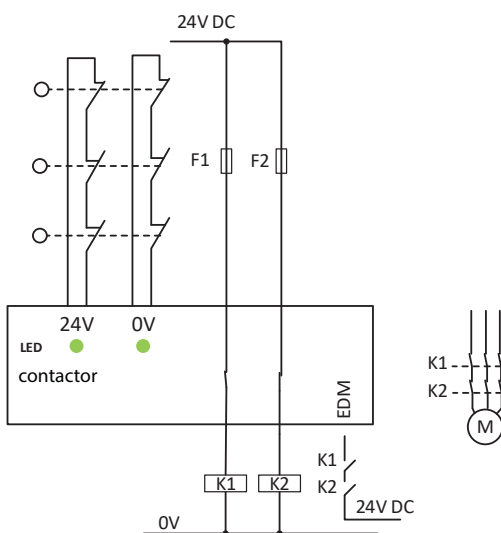
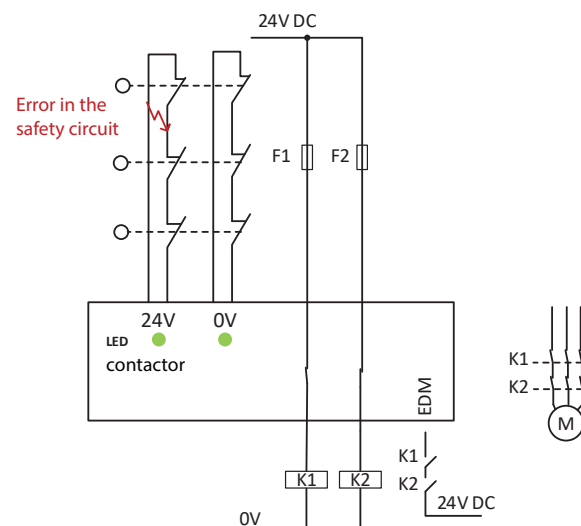

Figure 2:

All doors are closed. Error present in safety circuit (cross-circuit), error not detected by safety relay, motor is running



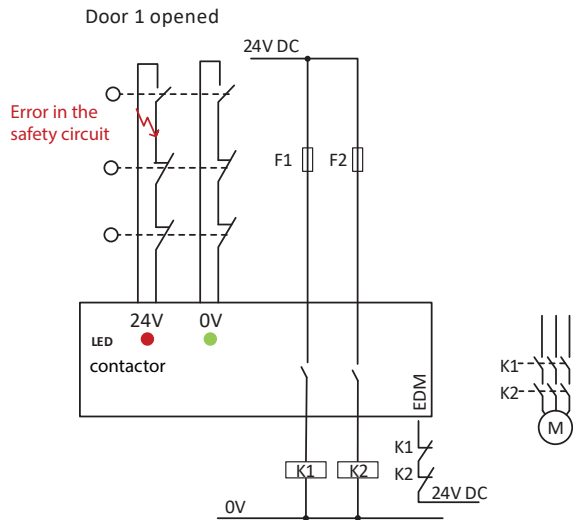

Figure 3:

Door 1 opened. Error present in the safety circuit, 2-channel error is detected by the safety relay (only one channel switches off), motor is stopped

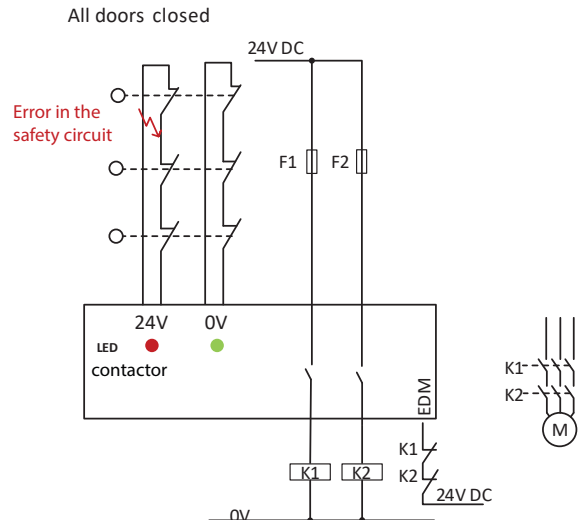

Figure 4:

All doors are closed. Error present in the safety circuit, 2-channel error is detected by the safety relay, motor is stopped

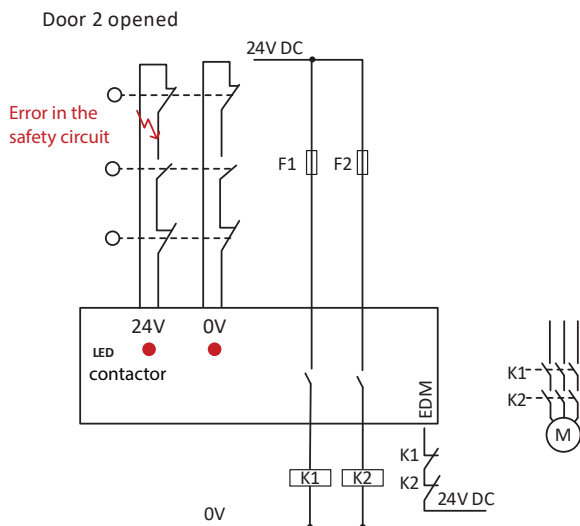

Figure 5:

Door 2 opened. Error present in safety circuit, errors are cleared in safety relay by opening both channels, motor is stopped

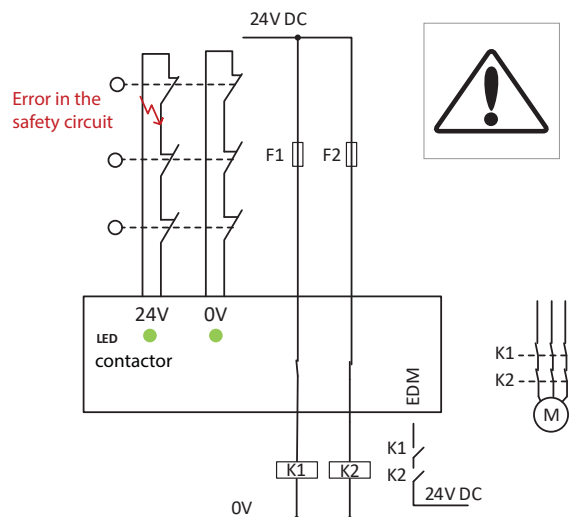

Figure 6:

All doors are closed. Error in the safety circuit, no error detected in the safety relay (error overwritten by opening both channels), motor running

DID YOU KNOW...



... that SAFIX 3 and HOLDX R have safe OSSD outputs in the output circuit?

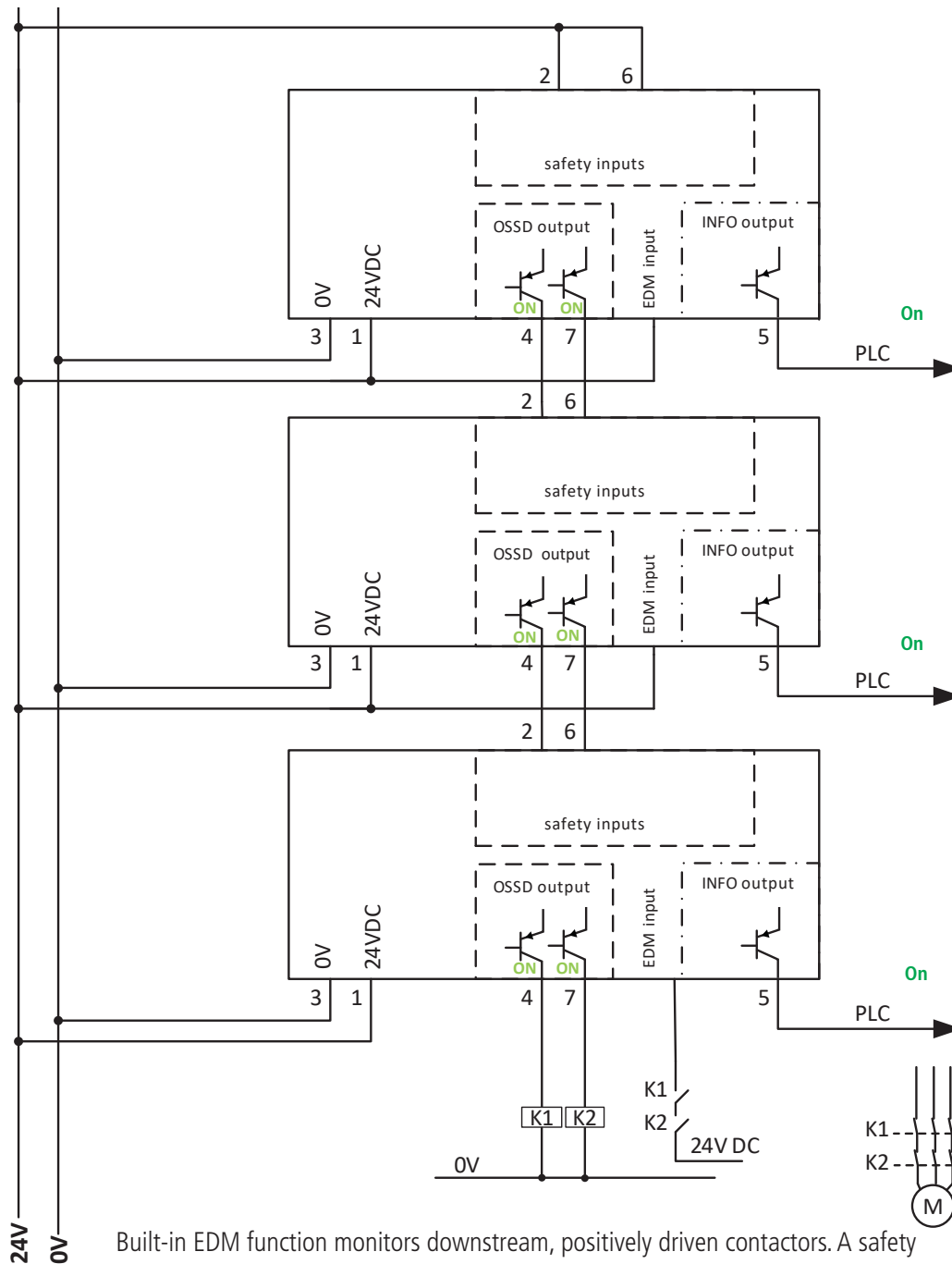

Built-in EDM function monitors downstream, positively driven contactors. A safety relay is no longer necessary.

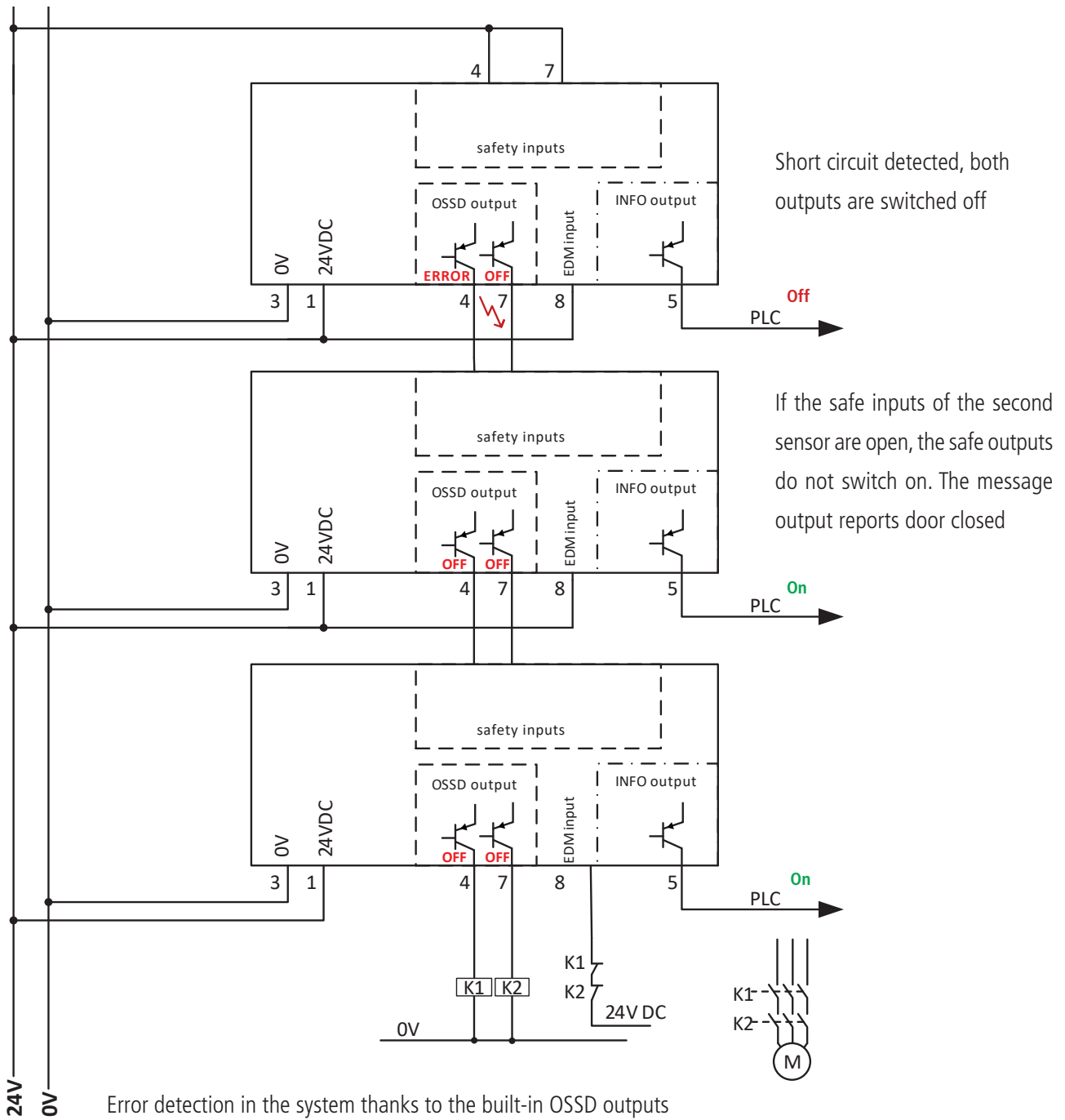

The use of OSSD outputs changes neither the wiring category nor the diagnostic coverage (DC) according to EN ISO 13849-1:2015. Every single error that occurs is detected in the system and leads to a safe shutdown. Several safety switches up to PLe can be connected in series without any problems.

If the safety switches are cascaded (connected in series), only the PFHD value of the entire circuit must be calculated. For the validation software SISTEMA libraries are available which can be downloaded from the SSP website.

XCONN

Passive Junction for Easy Wiring



Y-distributor for two SAFIX safety sensors or HOLDX process lock.

XCONN Y-M12 Y-distributor

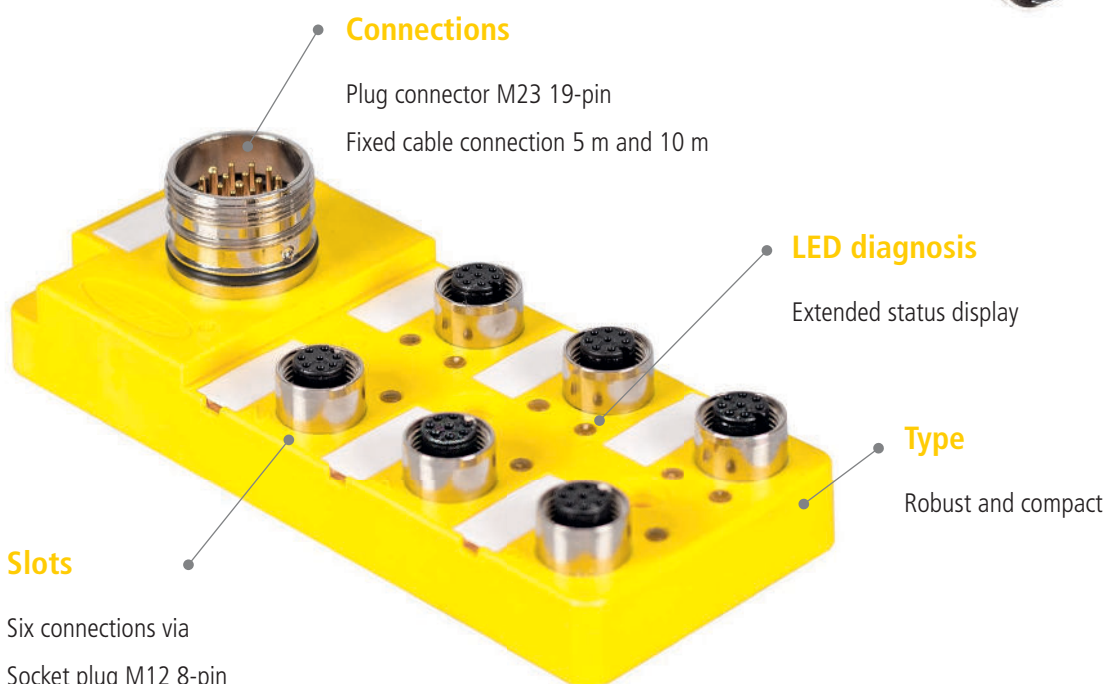

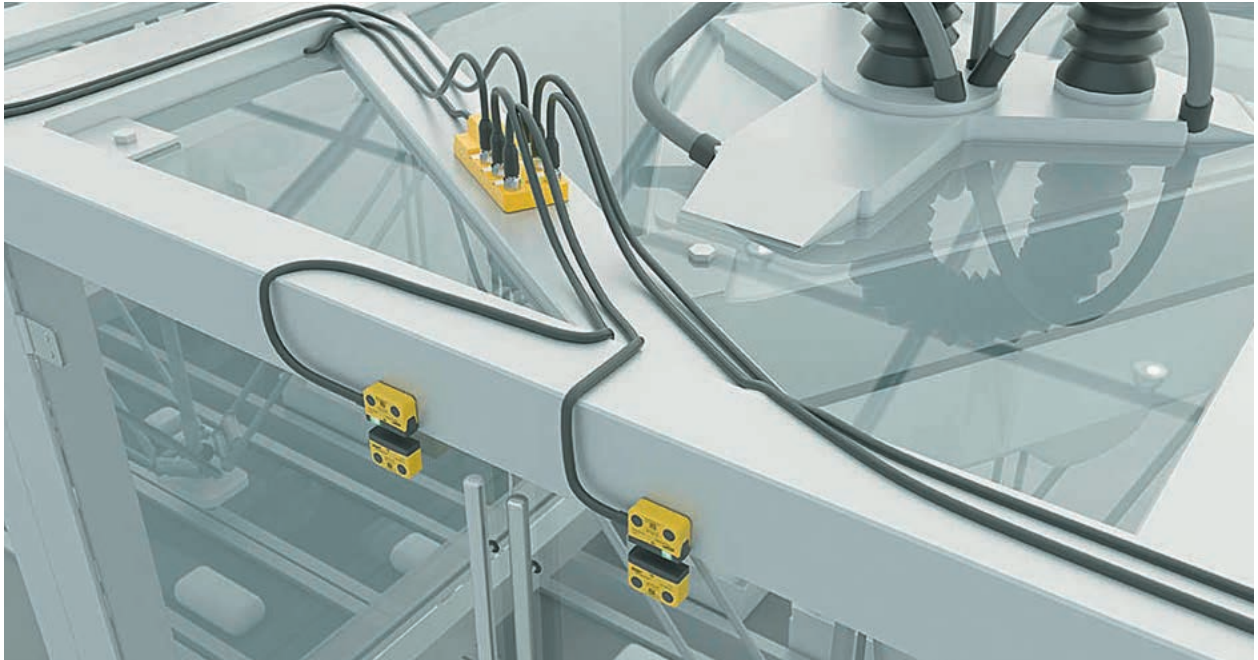

- ✓ Simple extension
- ✓ Fast planning
- ✓ Reduction of wiring
- ✓ Reduction of safe I/O Reduction of the software validation
- ✓ LED diagnosis on the plant

Connection diagram

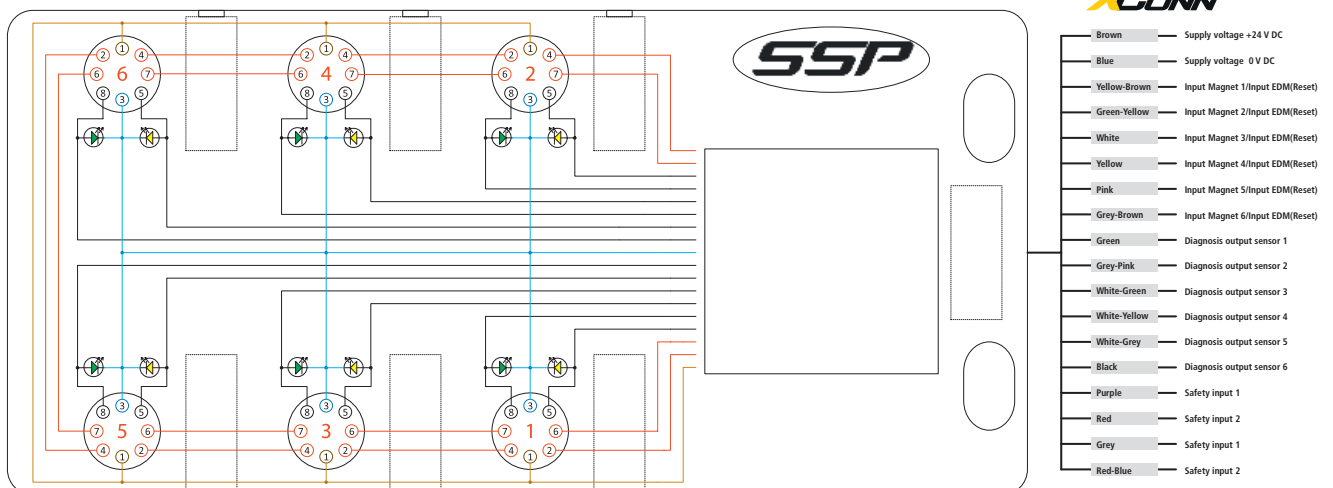

Safety Simplifier



The Simplifier wireless distributor offers unique advantages, with M12 8-pin slots and integrated safety controller with wireless communication.

Up to 4 safe I/O's are available at one slot with M12 8-pin socket plug.

There is no need for an additional safety control or bus system. Communication can be established stand-alone or decentralized via wireless or CAN connection.

Example with a safety guard locking: Two safe OSSD outputs, a door open/close status message and the safe control of the unlocking magnet can be connected and controlled via the Simplifier distribution box.

In this way, the 8-pin slots not only enable safe evaluation, but also diagnosis of the door position.



Wireless Distributors

4 SAFE I/O
PER SLOT

Connection options

Emergency stop

Inputs with cross-circuit monitoring



RFID safety sensor

Inputs for OSSD signals



Process lock

Inputs for OSSD signals,
control of the magnet



RFID safety switch

Inputs for OSSD signals,
control of the magnet



Safety light curtain

Inputs for OSSD signals

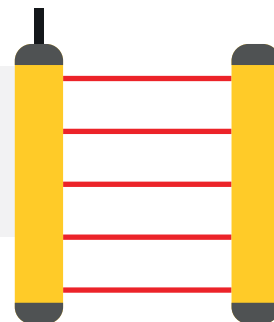

Safety valve

Control and evaluation of safety
valves



SSP

Safety System Products

SSP Safety System Products GmbH & Co. KG

Zeppelinweg 4 · 78549 Spaichingen · Germany

Tel. +49 7424 98049-0 · Fax +49 7424 98049-99

www.safety-products.de · info@ssp.de

INTERNATIONAL PARTNERS

Find them on our website

www.safety-products.de



Our contribution

Environmentally friendly paper
FSC®, EU Ecolabel



Modifications and errors excepted

December 2022 | 4.0

1001870

we simplify safety