

MOTION CONTROL DRIVES

SINAMICS Converters for Single-Axis Drives

SINAMICS G220

Built-in and wall-mounted units

[siemens.com/d36-1](https://www.siemens.com/d36-1)

















Catalog
D 36.1

Edition
June
2024

Next
Generation

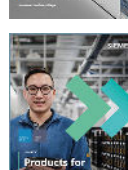

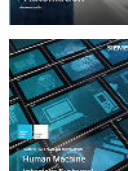
Related catalogs

<p>Motion Control Drives D 31.1 SINAMICS Converters for Single-Axis Drives Built-In Units</p> <p>PDF (E86060-K5531-A111-A4-7600)</p>		<p>SIMOTICS S-1FG1 D 41 Servo geared motors Helical, Parallel shaft, Bevel and Helical worm geared motors</p> <p>PDF (E86060-K5541-A101-A6-7600)</p>	
<p>Motion Control Drives D 31.2 SINAMICS Converters for Single-Axis Drives Distributed Converters</p> <p>PDF (E86060-K5531-A121-A3-7600)</p>		<p>Motion Control NC 63 SINUMERIK ONE Equipment for Machine Tools</p> <p>PDF (E86060-K4463-A101-A7-7600)</p>	
<p>Motion Control Drives D 31.5 SINAMICS Converters for Single-Axis Drives SINAMICS G120X infrastructure converters for HVAC/Water/Wastewater</p> <p>PDF (E86060-K5531-A151-A4-7600)</p>		<p>Motion Control NC 64 SINUMERIK MC Equipment for woodworking, glass working and stone working machines, as well as special technologies</p> <p>PDF (E86060-K4464-A101-A3-7600)</p>	
<p>Motion Control Drives D 32 SINAMICS S210 Servo Drive System</p> <p>PDF (E86060-K5532-A101-A8-7600)</p>		<p>Motion Control NC 82 SINUMERIK 828 Equipment for Machine Tools</p> <p>PDF (E86060-K4482-A101-B1-7600)</p>	
<p>Motion Control Drives D 33 SINAMICS V90 Basic Servo Drive System</p> <p>PDF (E86060-K5533-A101-A3-7600)</p>		<p>Industrial Controls IC 10 SIRIUS</p> <p>PDF (E86060-K1010-A101-B5-7600)</p>	
<p>Motion Control Drives D 34 SIMATIC MICRO-DRIVE Servo Drive System</p> <p>PDF (E86060-K5534-A101-A3-7600)</p>		<p>Low-Voltage Power Distribution and Electrical Installation Technology LV 10 SENTRON • SIVACON • ALPHA</p> <p>PDF (E86060-K8280-A101-B7-7600)</p>	
<p>SINAMICS S120 D 21.3 Chassis Format Converter Units Chassis-2 Format Converter Units Cabinet Modules, Cabinet Modules-2 SINAMICS S150 Converter Cabinet Units PDF (E86060-K5521-A131-A9-7600)</p>		<p>SIMATIC ST 70 Products for Totally Integrated Automation</p> <p>PDF (E86060-K4670-A101-C0-7600)</p>	
<p>Motion Control Drives D 21.4 SINAMICS S120, SINAMICS S220 and SIMOTICS</p> <p>PDF (E86060-K5521-A141-A2-7600)</p>		<p>SIMATIC HMI / PC-based Automation ST 80/ST PC Human Machine Interface Systems PC-based Automation</p> <p>PDF (E86060-K4680-A101-D1-7600)</p>	
<p>Motion Control Drives D 37.1 SINAMICS S200 Servo drive system</p> <p>PDF (E86060-K5537-A111-A1-7600)</p>		<p>SiePortal Information and Ordering Platform on the Internet</p> <p>sieportal.siemens.com</p>	

Catalog
D 36.1

Edition
June
2024

Next
Generation

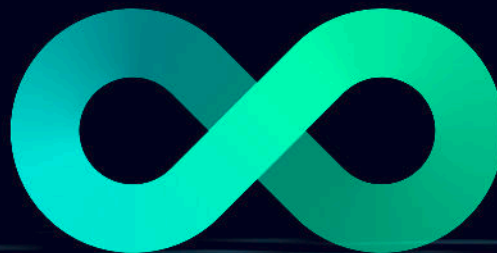

Combining the real and digital worlds ...
Transformation

MOTION CONTROL DRIVES

SINAMICS Converters for Single-Axis Drives

SINAMICS G220

Built-in and wall-mounted units

[siemens.com/d36-1](https://www.siemens.com/d36-1)

Dear Customer,

We are happy to present you with the new PDF version of the Catalog D 36.1 · June 2024.

The catalog provides a comprehensive overview of the SINAMICS G220 built-in and wall-mounted units including the innovative SINAMICS G220 Clean Power to reduce effectively line harmonics. The new SINAMICS G220 is an efficient, secure and future-proof converter system that has been specifically developed for high-performance applications in manufacturing, process industries and marine infrastructure.

The products listed in this Catalog are also included in SiePortal.
Please contact your local Siemens office for additional information.

Up-to-date information about SINAMICS G220 is available online at www.siemens.com/sinamics-g220

You can access SiePortal on the internet at <https://sieportal.siemens.com>

Your personal contact will be glad to receive your suggestions and recommendations for improvement. You can find your representative in our personal contacts database at www.siemens.com/automation-contact

We hope that you will often enjoy using the new Catalog D 36.1 · June 2024 as a selection and ordering reference document and wish you every success with our products and solutions.

With kind regards

Frank Golüke
Vice President
General Motion Control
Siemens AG, Digital Industries, Motion Control

Siemens
EcoTech



SINAMICS Converters for Single-Axis Drives

SINAMICS G220 built-in and wall-mounted units

Motion Control Drives



Catalog D 36.1 · June 2024

Supersedes:
Catalog D 36.1 · April 2024

Refer to SiePortal for current updates of this catalog:
<https://sieportal.siemens.com>

Please contact your local Siemens branch.

© Siemens 2024

Click on an Article No. in the catalog PDF to call it up in SiePortal and to obtain all the information.

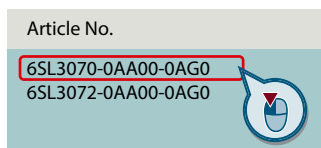

Or directly on the internet, e.g.
www.siemens.com/product_catalog_DIMC?6SL3070-0AA00-0AG0



The products and systems described in this catalog are manufactured/distributed under application of a certified quality management system in accordance with EN ISO 9001. The certificate is recognized by all IQNet countries.

System overview

1

SINAMICS G220 built-in and wall-mounted units

2

Engineering tools

3

Services and documentation

4

Appendix

5



Motion beyond expectations

Drives move the industries. But how can they make them more efficient, more reliable and more sustainable – and exceed all expectations while they are doing it? Our answer: Siemens Xcelerator for Digital Drivetrain.

Digital solutions for Drivetrain Design and Drivetrain Health

Combine the real and the digital world to reach the next level of efficiency and sustainability in your drivetrain value chain: with suitable digital solutions for drivetrain design and drivetrain health.

Drivetrain Design:

Simplify and shorten the engineering steps to get faster and more efficiently from concept to the commissioned drivetrain.

Drivetrain Health:

Reduce total cost of ownership for your equipment and machine park – energy, maintenance, downtime.

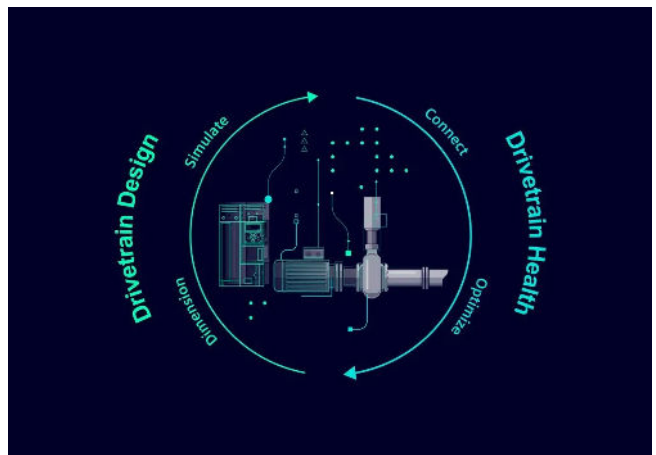

[siemens.com/digital-drivetrain](https://www.siemens.com/digital-drivetrain)

Digitalization along the drivetrain value chain



Dimension

Accurate in motion: Dimension your motors, gearboxes, and complete drivetrains digitally with greater precision – for greater reliability and energy efficiency.



Simulate

Faster in motion: Add the digital twin of the drivetrain to your machine simulation to speed up your design and engineering phases and to accelerate your time-to-market!



Connect

Data in motion: Acquire high-quality raw data and connect your entire drivetrains or machines to cloud or on-premise platforms – for a consistent and secure data flow.



Optimize

Better in motion: Analyze and visualize drivetrain and machine data in digital solutions and apps to identify optimization potentials and concrete actionable measures how to tap it.

Use cases for digital drivetrain technology



Condition monitoring for drivetrains

Healthy in motion: Gain valuable insights into your drivetrain to optimize maintenance, system availability, cost efficiency, and sustainability: Discover intelligent digital condition monitoring for your drivetrains!

Are your drivetrains fit enough for tough times?

The industries are expected to produce ever more efficiently, ever more sustainably and ever more cost-effectively. And if you can't do that, it's easier to be left behind by the competition. Use digitalization and the data from your motors and converters to optimize your competitiveness – and to keep your production in motion.



What if you consume too much electricity?

With digital solutions and digital drive technology, you can significantly reduce your share of this!



What if you waste too much energy?

Digitalization enables you to detect energy waste and impending system downtimes at an early stage so that you can take counter-measures in due time!



What if your motors are incorrectly designed?

Digital tools make it quicker and easier to correctly design your drive components!



What if your drives fail unexpectedly?

With digital solutions, you can identify risks in your drivetrain at an early stage and react before a failure occurs.

"Our digital solutions transform your drivetrain value chain to the next level of efficiency and sustainability."



SINAMICS frequency converters

SINAMICS frequency converters – the ultimate solution for all drive applications. From low voltage to medium voltage to direct current (DC), our frequency converters meet your needs. With increased efficiency and versatility, take your applications to the next generation for a digital and sustainable future.

Driving next generation applications

When it comes to driving industry advancements, look no further than our SINAMICS frequency converters. They fuel the creation of innovative, next-generation applications that meet the unique needs of every industry.

From pumping and ventilating to moving, positioning, processing, and machining, our converters have you covered. Get ready to take your applications to new heights.



Low voltage converters

Low voltage frequency converters are suitable for a huge range of applications. For example, if materials must be moved, processed, positioned, pumped or compressed. Variable-speed operation saves energy and also increases process quality and process availability.



Medium voltage converters

Medium voltage converters for motor voltages in the range from 1.4 kV up to 13.8 kV. Medium voltage converters for high voltage motors are used when the required drive power and/or voltage is too high for low voltage drive solutions and to address special applications.



Servo converters

These servo converters meet the highest dynamic requirements for single and multi-axis applications. The perfect solution for machine tools, packaging machines, continuous material handling, cranes, rolling mills, test stands, material handling, robotics and many other applications requiring high-precision, dynamic motion control.



DC converters

The dynamic performance, ruggedness, and cost-effectiveness of DC technology continue to make it the most cost-effective and proven drive solution for many applications today – with numerous advantages in terms of reliability, ease of use, and operational performance.



Accelerating the digital and sustainable transformation of industry

How can you make production more efficient? Accelerate your digital transformation? And become more sustainable?

The answer is our SINAMICS frequency converters. They are energy efficient, offer the versatility you need for any application, and drive your digital transformation by providing the data to continuously improve production efficiency and sustainability. Our converters offer you integrated safety and security features, efficient engineering and software tools as well as comprehensive lifecycle services. In other words: Everything you need to address the next generation of applications – today and tomorrow.

EFFICIENT

Implement energy-efficient applications easily, quickly, and safely with efficient motion control.

- Sustainable drive systems
- Efficient Motion Control solutions
- Drive System Services

VERSATILE

Drives equipped with tailored safety features to ensure optimal machine safety in a wide range of industrial applications.

- Safety and Security Integrated
- Drive applications
- Drives for any industry

FUTURE-PROOF

Efficient engineering, powerful software tools, and cloud and edge connectivity for greater transparency.

- Digitalization in drive technology
- Efficient drive engineering
- Drive Software for all applications

Totally Integrated Automation



Totally Integrated Automation (TIA) offers smart automation development, flexible machine concepts, transparent operation, and sustainable solutions that enable access to data to calculate and optimize the product carbon footprint. We are constantly improving and expanding TIA to be future-proof and adaptive to existing and upcoming challenges.

A comprehensive portfolio for the challenges of today and tomorrow

The TIA offering is integrated seamlessly and it's so comprehensive that it provides the right automation solutions for every industry. We will continue to improve and expand our proven automation portfolio and are constantly including innovative technologies and solutions that pave the way towards the factory of the future.

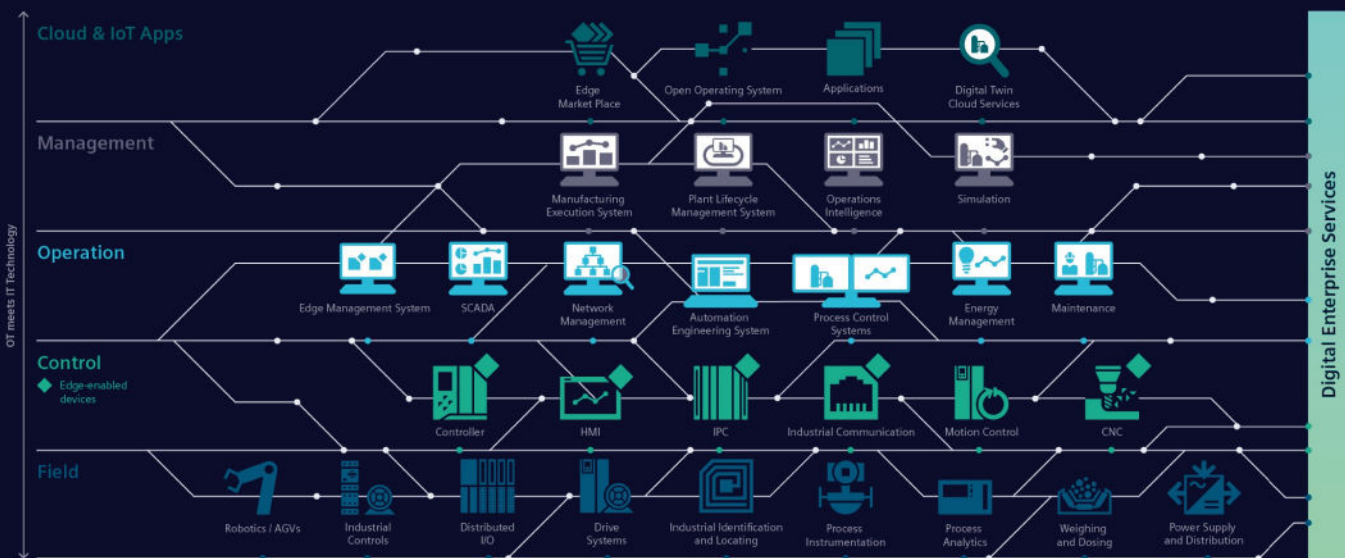

Real added value for the automation of your production

From the development of innovative machine concepts to engineering and optimized production:

TIA offers real added value along the entire value chain.

Smart Automation Development

Innovative machine concepts made easy: When you use standardized library concepts and preconfigured expertise, you can count on efficient engineering. Thanks to the integration of safety features, diagnostic functions, and cybersecurity, you also save valuable time.

Flexible Machine Concepts

No matter what new requirements emerge in the market, TIA supports modular machine concepts and the simple integration of new machines into existing lines – thanks to standardized hardware interfaces and engineering libraries. As a machine builder, this enables you to meet any challenge quickly and reliably.

Transparent Operation

Integrated interfaces let you achieve a new level of transparency for the essential performance indicators in your processes and plants. The connection between IT and OT along with efficient data management lay the foundation for new service models such as predictive maintenance.

Future-proof Automation

Our TIA portfolio is constantly being refined with a view to integrating automation technologies more and more efficiently. The components can then interact with modern IT capabilities, which are becoming increasingly important for specific applications in automation. TIA provides a solid foundation, whether for working with our Industrial Operations X portfolio or for everything the future has in store.

Sustainable Solutions

Sustainability starts with the acquisition of data. With the TIA portfolio, you can measure energy and resource data and make it transparent, providing a solid foundation for calculating the Product Carbon Footprint. This is crucial for drawing the right conclusions and responding to sudden changes in order to lastingly reduce CO₂ emissions and save more resources in production.

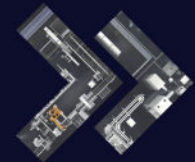

www.siemens.com/tia



TIA Selection Tool – quick, easy, smart configuration

For you to get the most out of our portfolio quickly and easily.

Do you always need the optimum configuration for planning your project?

For your application we offer the TIA Selection Tool to support all project planners, beginners and experts alike.

No detailed portfolio knowledge is necessary.

TIA Selection Tool is available for download as a free desktop version or a cloud variant.

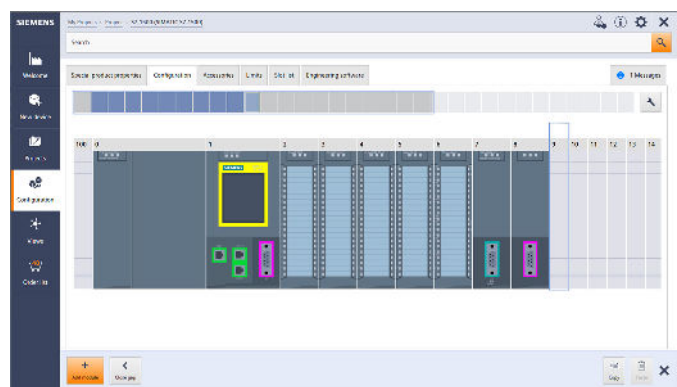

Your Advantages

Quick

- Configure a complete project with just a few entries – without a manual, without special knowledge
- Import and export of hardware configuration to TIA Portal or other systems
- Ideal visualization of the projects to be configured

Easy

- Tool download either as desktop version or web-based cloud version
- Technically always up-to-date about product portfolio and innovative approaches
- Highly flexible, secure, cross-team work in the cloud
- Direct ordering in SiePortal

Smart

- Smart selection wizard for error-free configuration and ordering
- Configuration options can be tested and simulated in advance
- Library for archiving sample configurations

The TIA Selection Tool is a completely paperless solution.

Download it now:

www.siemens.com/tst

For more
information,
scan the
QR code





Sustainability @Siemens

Transforming the everyday to create a better tomorrow.



For more information, see www.siemens.com/sustainability-figures

As a company, Siemens considers environmental, social and governance (ESG) criteria from all angles with its DEGREE framework (decarbonization, ethics, governance, resource efficiency, equity and employability). We are not only committed to reducing the carbon footprint in our own operations to net zero by 2030, but also helping our customers achieve their decarbonization and sustainability goals.

Mission & strategy

As a focused technology company, Siemens is committed to addressing the world's most profound challenges by leveraging the synergies between digitalization and sustainability.

Technology with aim and purpose

We develop technologies that connect the real and digital worlds and enable our customers to positively transform the industries that form the backbone of our economy: industry, infrastructure, transportation and healthcare.

Our contribution

Siemens makes an impact every day by providing innovative solutions in response to challenges relating to environmental protection, decarbonization, health and safety. Innovative solutions that have a clear goal: to make the world more sustainable, more integrative and a better place to live.

Sustainability facts

For almost 175 years, Siemens has been driven by the desire to improve the lives of people around the world with our technologies.

System overview



1/2	The SINAMICS converter family
1/3	Drive selection
1/4	SIMOTICS motors
1/5	Energy efficiency classes in accordance with IEC 61800-9-2
1/8	SINAMICS Drive Software
1/8	Overview
1/10	Motor Control Functions
1/12	Technology Functions
1/14	SINAMICS G220 built-in and wall-mounted units
1/15	SINAMICS G220 starter kits

Further information about SINAMICS can be found on the internet at www.siemens.com/sinamics

System overview

The SINAMICS converter family

1

Overview

SINAMICS frequency converters

SINAMICS frequency converters are the ultimate solution for all drive applications. From low voltage to medium voltage to direct current (DC), our frequency converters meet your needs.

With increased efficiency and versatility, take your drive applications to the next generation for a digital and sustainable future.

www.siemens.com/sinamics





Low voltage											Direct voltage
Standard performance frequency converters		Distributed frequency converters	Industry-specific frequency converters		Servo converters			High performance frequency converters			DC converters
SINAMICS V20 G120C G120	SINAMICS G130 G150	SINAMICS G115D G120D SIMATIC ET 200pro FC-2	SINAMICS G120X	SINAMICS G180	SINAMICS V90 S200	SINAMICS S110	SINAMICS S210 S210 (New)	SINAMICS G220	SINAMICS S120 S120M	SINAMICS S150	SINAMICS DCM DCP ¹⁾
0.12 kW to 250 kW	75 kW to 2700 kW	0.37 kW to 7.5 kW	0.75 kW to 630 kW	2.2 kW to 6600 kW	0.05 kW to 7 kW	0.55 kW to 132 kW	0.05 kW to 7 kW	0.55 kW to 55 kW	0.55 kW to 5700 kW	75 kW to 1200 kW	6 kW to 30 MW
Pumps, fans, compressors, conveyor belts, mixers, mills, spinning machines, textile machines, refrigerated display counters, fitness equipment, ventilation systems, single-axis positioning applications in machine and plant engineering	Pumps, fans, compressors, conveyor belts, mixers, mills, extruders	Conveyor technology, single-axis positioning applications (G120D)	Pumps, fans, compressors, building management systems, process industry, HVAC, water/waste water industries	Pumps, fans, compressors, conveyor belts, extruders, mixers, mills, kneaders, centrifuges, separators	Handling machines, packaging machines, automatic assembly machines, metal forming machines, printing machines, winding and unwinding units	Single-axis positioning applications in machine and plant engineering	Packaging machines, handling equipment, feed and withdrawal devices, stacking units, automatic assembly machines, laboratory automation, wood, glass and ceramics industry, digital printing machines	Pumps, fans, compressors, conveyor belts, mixers, mills, spinning machines, textile machines, refrigerated display counters, fitness equipment, ventilation systems, single-axis positioning applications in machine and plant engineering	Production machines (packaging, textile and printing machines, paper machines, plastic processing machines), machine tools, plants, process lines and rolling mills, marine drives, test bays	Test bays, cross cutters, centrifuges	Rolling mill drives, wire-drawing machines, extruders and kneaders, cableways and lifts, test bay drives
Catalog D 31.1	Catalog D 11	Catalog D 31.2	Catalog D 31.5	Catalog D 18.1	Catalog D 33 D 37.1	Catalog D 31.1	Catalog D 32	Catalog D 36.1	Catalogs D 21.3, D 21.4 NC 62	Catalog D 21.3	Catalog D 23.1, SiePortal

Engineering tools (e.g. Siemens Product Configurator, TIA Selection Tool, DriveSim Designer/Engineer, STARTER and SINAMICS Startdrive)

¹⁾ DC/DC controllers, see SiePortal.

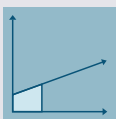
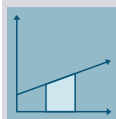
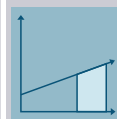
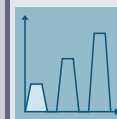
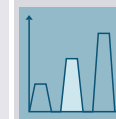
Overview

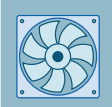
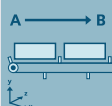
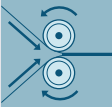
SINAMICS selection guide – typical applications

Use	Requirements for torque accuracy/speed accuracy/position accuracy/coordination of axes/functionality					
	Continuous motion			Non-continuous motion		
	Basic	Medium	High	Basic	Medium	High
						
Pumping, ventilating, compressing 	Centrifugal pumps Radial / axial fans Compressors V20 G120C G120X	Centrifugal pumps Radial / axial fans Compressors G120X G130/G150 G180 ¹⁾ DCM	Eccentric screw pumps G220 S120	Hydraulic pumps Metering pumps G120/ G220	Hydraulic pumps Metering pumps S110	Descaling pumps Hydraulic pumps S120
Moving 	Conveyor belts Roller conveyors Chain conveyors V20 G115D G120C ET 200pro FC-2 ²⁾	Conveyor belts Roller conveyors Chain conveyors Lifting/ lowering devices Elevators Escalators/ moving walkways Indoor cranes Marine drives Cable railways G120/ G220 G120D G130/G150 G180 ¹⁾	Elevators Container cranes Mining hoists Excavators for open-cast mining Test bays G220 S120 S150 DCM	Acceleration conveyors Storage and retrieval machines V90 S200 G120/ G220 G120D	Acceleration conveyors Storage and retrieval machines Cross cutters Reel changers S110 S210 DCM	Storage and retrieval machines Robotics Pick & place Rotary indexing tables Cross cutters Roll feeds Engagers/ disengagers S120 S210 DCM
Processing 	Mills Mixers Kneaders Crushers Agitators Centrifuges V20 G120C	Mills Mixers Kneaders Crushers Agitators Centrifuges Extruders Rotary furnaces G120/ G220 G130/G150 G180 ¹⁾	Extruders Winders/unwinders Lead/follower drives Calenders Main press drives Printing machines G220 S120 S150 DCM	Tubular bagging machines Single-axis motion control such as Position profiles Path profiles V90 S200 G120/ G220	Tubular bagging machines Single-axis motion control such as • Position profiles • Path profiles S110 S210	Servo presses Rolling mill drives Multi-axis motion control such as • Multi-axis positioning • Cams • Interpolations S120 S210 DCM
Machining 	Main drives for • Turning • Milling • Drilling S110	Main drives for • Drilling • Sawing S110 S120	Main drives for • Turning • Milling • Drilling • Gear cutting • Grinding S120	Axis drives for • Turning • Milling • Drilling S110	Axis drives for • Drilling • Sawing S110 S120	Axis drives for • Turning • Milling • Drilling • Lasering • Gear cutting • Grinding • Nibbling and punching S120

Using the SINAMICS selection guide

The varying range of demands on modern variable frequency drives requires a large number of different types. Selecting the optimum drive has become a significantly more complex process. The application matrix shown simplifies this selection process considerably, by suggesting the ideal SINAMICS drive for examples of typical applications and requirements.

- The application type is selected from the vertical column
 - Pumping, ventilating, compressing
 - Moving
 - Processing
 - Machining
- The quality of the motion type is selected from the horizontal row
 - Basic
 - Medium
 - High

More information

Further information about SINAMICS is available on the internet at www.siemens.com/sinamics

Practical application examples and descriptions are available on the internet at www.siemens.com/sinamics-applications

¹⁾ Industry-specific converters.

²⁾ Information on the SIMATIC ET 200pro FC-2 frequency converter is available in Catalog D 31.2 and at www.siemens.com/et200pro-fc

System overview

SIMOTICS motors

Overview

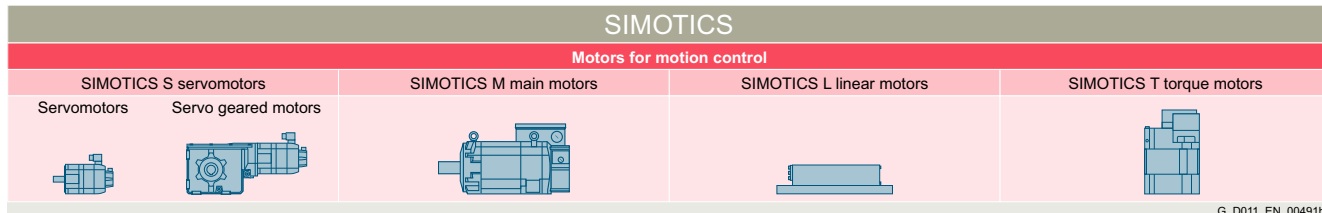

SIMOTICS stands for

- 150 years of experience in building electric motors
- The most comprehensive range of motors for motion control applications
- Optimum solutions in all industries, regions and power/performance classes
- Innovative motor technologies of the highest quality and reliability
- Highest dynamic performance, precision and efficiency together with the optimum degree of compactness
- Our motors can be integrated into the drive train as part of the overall system
- A global network of skill sets and worldwide service around the clock

A clearly structured portfolio

The entire SIMOTICS product portfolio is transparently organized according to application-specific criteria in order to help users select the optimum motor for their application.

Whatever it is that you want to move – we can supply the right motor for the task.

www.siemens.com/simotics

An outstanding performance for any job

A key characteristic of all SIMOTICS motors is their quality. They are robust, reliable, dynamic and precise to assure the requisite performance level for any process and deliver exactly the capabilities demanded by the application in hand. Thanks to their compact design, they can be integrated as space-saving units into installations. Furthermore, their impressive energy efficiency makes them effective as a means of reducing operating costs and protecting the environment.

A dense network of skill sets and servicing expertise around the world

SIMOTICS offers not only a wealth of sound experience gleaned from a development history which stretches back over around 150 years, but also the know-how of hundreds of engineers. This knowledge and our worldwide presence form the basis for a unique proximity to industries which feeds through in tangible terms to the specific motor configuration which is tailored to suit your application.

Our specialists are available to answer all your queries regarding any aspect of motor technology. At any time – wherever you are in the world. When you choose SIMOTICS, therefore, you reap the benefits of a global service network which is continuously accessible, thereby helping to optimize response times and minimize downtimes.

Perfection of the complete drive train

SIMOTICS is perfectly coordinated with other Siemens product families. In combination with the SINAMICS integrated converter family and the SIRIUS complete portfolio of industrial controls, SIMOTICS fits seamlessly as part of the complete drive train into automation solutions which are based on the SIMATIC, SIMOTION and SINUMERIK control systems.

Overview

Step by step to more efficiency

One of the core objectives of the European Union is a sustainable power industry. In industrial plants today, around 70 % of the power demand is from electrically driven systems. This high percentage contains huge potential for saving energy in electrical drives. For that reason, the European Union introduced minimum requirements for the energy efficiency of electric motors in the form of a statutory motor regulation as early as 2011.

These activities are extended by the 2019/1781 EU regulation dealing with stricter requirements for DOL (Direct On Line) motors and defining efficiency limits for frequency converters. The regulation provides a legal basis for technical content regarding the efficiency of specific products and services. Standardization, however, has played a leading role in determining the field and the available market technology.

Energy efficiency improvement is supported through a systematic selection of the most efficient converter and drive system technology via the IEC 61800-9 series of standards. Part 1 specifies the methodology to determine the energy efficiency index of an application based on the extended product approach (EPA) and semi analytical models (SAMs), while Part 2 provides indicators for assessing the energy efficiency performance and the classification of converters and drive systems.

To take account of the different use cases, consideration of eight application-relevant operating points has been introduced as mandatory for the first time. Determination of loss values at these eight points and definition of efficiency classes are laid down by the standard in a uniform way. This enables data relevant to operation, such as application-specific load profiles, to now be taken into account more easily in the energy efficiency analysis.

The standard is especially important for variable-speed drives of the following types:

- for AC/AC converters without energy recovery functionality
- for motors with integrated converters
- for supply voltages of 100 V to 1000 V
- for power ratings of 0.12 kW to 1000 kW

To cover all applications of driven machines, the IEC 61800-9-2 standard defines operating points in full-load and partial-load operation, at which the losses of the motor and drive systems have to be determined. Based on the loss data at the operating points in partial-load operation, variable-speed drives can be explicitly considered in more detail. This makes their advantages especially clear.

Centrifugal pumps, fans

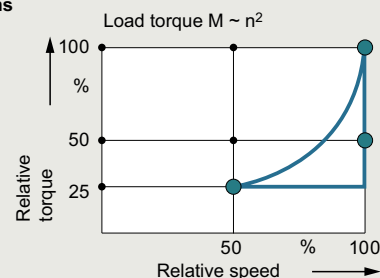

Hoisting gear, extruders, conveyor belts

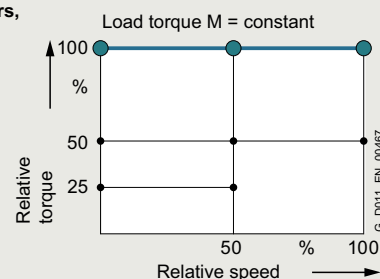
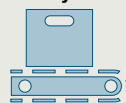

Winders, coilers

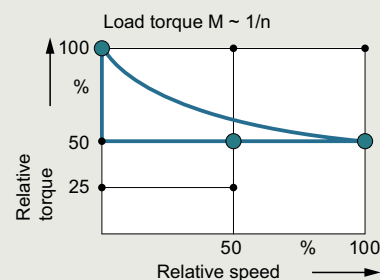

Duty cycles for different driven machines

Moreover, frequency converters and motor systems are classified in efficiency classes, which permit an initial rough estimate of the potential saving. Definition of reference systems is a key aspect of this because they provide standard reference values. The positioning of these reference systems defines the efficiency class. The relative distance from the reference system can be used as an absolute measure of the efficiency at the operating point in question.

System overview

1

Energy efficiency classes in accordance with IEC 61800-9-2

Overview

Advantages of the detailed loss consideration of IEC 61800-9-2 over the previous consideration of efficiencies and maximum loss values

For motors, the efficiency consideration was previously only defined for operation without a converter at 50/60 Hz. It provides a good way of comparing the energy efficiency of motors from different manufacturers for this use case.

The more detailed loss analysis of IEC 61800-9-2, on the other hand, is aimed at speed-controlled operation and therefore now also includes motors especially designed for converter operation in the energy analysis. These were previously not covered by the applicable standards.

Moreover, a loss analysis over the entire setting and load range of the motor is possible. This is done in accordance with the standard IEC 61800-9-2 with typical values.

For holistic consideration, it is essential to include all the relevant components of a drive system. The IEC 61800-9-2 standard defines this in detail. The standardized expression of power loss data as a percentage makes comparison considerably easier and more transparent.

The method also makes it possible to consider a motor that produces a holding torque at speed zero, for example. In this case, the efficiency is zero, but a power loss from current producing magnetization and holding torque does occur. In summary, the key advantage of standard IEC 61800-9-2 is the ability to perform the energy analysis of an electrical drive system based on standardized load profiles in all operating ranges due to uniform general conditions. This provides the user with complete transparency irrespective of the manufacturer.

Establishing efficiency classes of frequency converters (Complete Drive Modules CDM)

To avoid overmodulation and to ensure comparability between makes, which cannot be achieved otherwise, the efficiency classes of CDMs refer to the 90/100 operating point (90 % motor stator frequency, 100 % torque current).

Standard IEC 61800-9-2 defines the relative losses of a CDM in efficiency classes IE0 to IE2. With reference to the value of a CDM of efficiency class IE1 (reference converter), a CDM of efficiency class IE2 has 25 % lower losses and a CDM of efficiency class IE0 has 25 % higher losses.

The publication of the 2019/1781 EU regulation has made mandatory the fulfillment of the ecodesign requirements for the declaration of product conformity.

AC/AC converters belonging to the aforementioned categories (specific voltage and power level without regenerative capability) have to fulfill efficiency class IE2 in order to be approved for installation/utilization within EU.

Operating points for CDMs

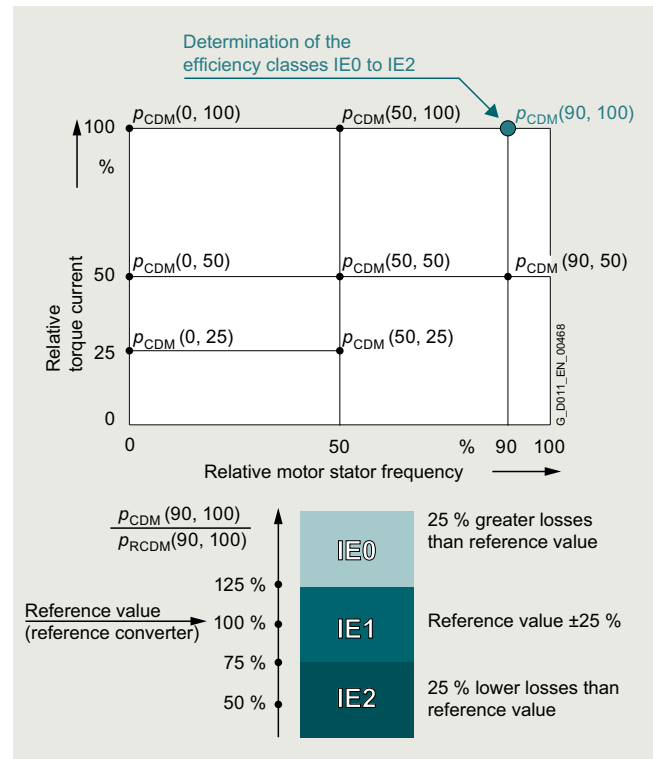

Complete Drive Module (CDM) – determining the efficiency class

Establishing the efficiency classes of drive systems (Power Drive Systems PDS)

What is possible for the individual systems, of course, also applies to the entire electrical PDS (frequency converter plus motor). Detailed comparisons are now possible at this level, too. The reference values for the reference system provide clear indications of the energy performance of the PDS.

Because targeted matching of the motor and CDM provides additional potential for optimization in electrical drive systems, it is especially important for the user to consider the entire drive system.

For the efficiency class of a PDS, too, a specific load point is defined. In this case, the reference point used is the 100/100 operating point (100 % motor stator frequency, 100 % torque).

Standard IEC 61800-9-2 defines the relative losses of a PDS in efficiency classes IES0 to IES2. With reference to the value of a PDS of efficiency class IES1 (reference drive), a PDS of efficiency class IES2 has 20 % lower losses and a PDS of efficiency class IES0 has 20 % higher losses.

Energy efficiency classes in accordance with IEC 61800-9-2

Overview

Operating points for PDS

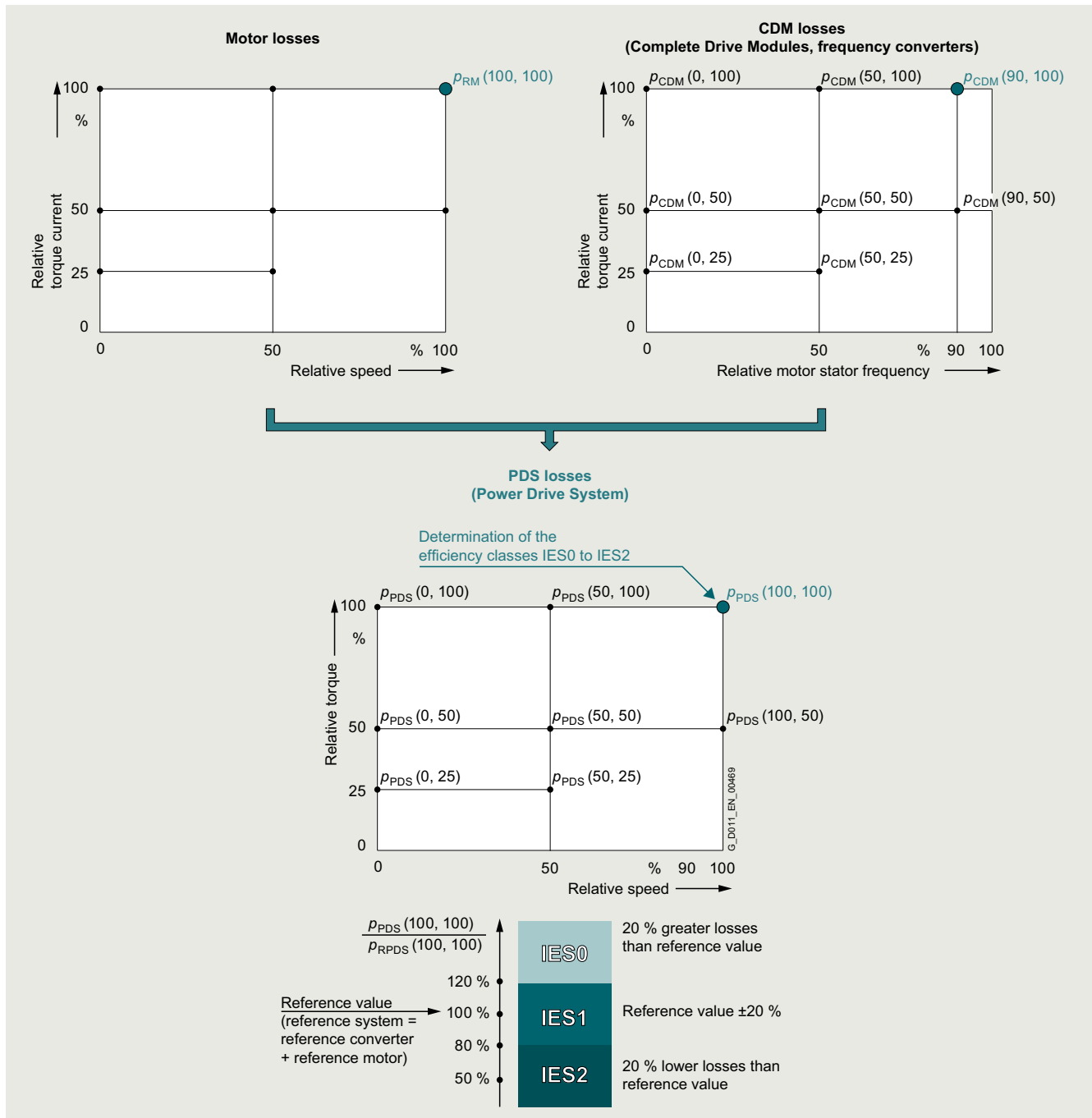

Power Drive System (PDS) – determining the efficiency class

More information

Power loss data of SINAMICS converters for single-axis drives are available

- for SINAMICS V20, SINAMICS G115D/G120/G120C/G120D/G120P/G120X/G130/G150/G180 and SINAMICS S110/S120/S150 on the internet at <https://support.industry.siemens.com/cs/document/94059311>
- for SINAMICS G220 via ID-Link or Siemens Product Configurator in SiePortal at www.siemens.com/sinamics-g220/configuration

More information on current laws and standards, new standards, and mandatory guidelines is available on the internet at www.siemens.com/legislation-and-standards

System overview

SINAMICS Drive Software > Overview

1

Overview

SINAMICS Drive Software – The right function for every application

SINAMICS Drive Software ensures that our SINAMICS frequency converters operate smoothly and reliably.

It offers comprehensive functionality, is easily expandable and enables the greatest possible flexibility for a wide range of applications.

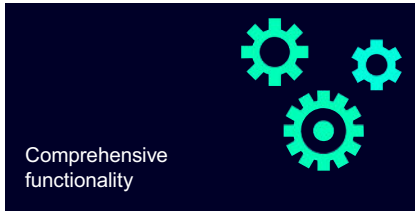

Comprehensive functionality

The software enables highly accurate and dynamic control of different types of motors.

Integrated functions help to reduce energy consumption. The software protects the converter against overload and ensures high availability. Furthermore, positioning tasks as well as logic and technology functions can be taken over directly by the drive.

The Safety Integrated functions ensure maximum safety for operating and maintenance personnel. The special requirements of industries and applications e. g. pumps, fans and conveyor technology are met by specific functions.



Easily expandable

Most of the SINAMICS Drive Software functionality is already included in the basic scope of our frequency converters.

However, the scope of performance can be further increased via additional SINAMICS Drive Software options.

These options allow the use of special added value or expansion functions.

For example, the SINAMICS Safety Integrated Extended option provides additional safety functions compared to the basic version.



Greatest flexibility

The additional SINAMICS Drive Software options can easily be ordered together with the SINAMICS frequency converter.

You do not know which options you need at the beginning?

No problem, besides options that can be ordered directly at the time of purchase, some options can also be ordered later.

Before purchasing, you can test the SINAMICS Drive Software options free of charge for a limited time (trial license concept).

Overview

**Motor Control Functions**

Basic – but most important!
From standard pump and fan applications to high-end drives with complex multi-axis servo applications: Motor control with SINAMICS drives is always perfect. A wide variety of motor technologies and performance levels with optimal settings for all applications can be controlled. Just the perfect control for your task!

**User Experience**

An excellent user experience is given throughout the whole engineering chain as well as throughout the whole drives portfolio due to consistent Ethernet-based interfaces, communication protocols (wired or wireless) as well as up to date browser technologies.

All of the converter functions have been designed so that they can be handled in the same way from an engineering perspective, irrespective of the selected drive type. Knowledge gained can therefore be reused easily and efficiently.

www.siemens.com/engineering-tools

**Security Integrated Functions**

Keep systems and data safe with Security Integrated.

With the new Security Integrated functions, we are hardening SINAMICS drives and therefore also your machines against cyber attacks from the outside (available for SINAMICS S200, SINAMICS S210 (New), SINAMICS G220).

www.siemens.com/industrial-cybersecurity

**Connectivity Functions**

Consistent openness today and tomorrow.

SINAMICS offers a comprehensive range of communication options for engineering, exchanging data between drives – and naturally for exchanging data with higher level automation systems.

www.siemens.com/profinet

**Technology Functions**

The SINAMICS drives' range of applications is significantly expanded by the Technology Functions. From logic to positioning and more – everything on board!

**Safety Integrated Functions**

SINAMICS drives offer comprehensive and integrated safety functions. These act significantly faster than conventional designs. As a consequence, Safety Integrated further increases the safety of a machine.

www.siemens.com/safety-drives

**Energy Efficiency and Grid Capability Functions**

Energy is valuable and should be used as efficiently as possible. SINAMICS drives offer integrated functions for energy efficiency and naturally also support PROfinenergy.

www.siemens.com/drives-energy-efficiency

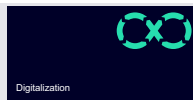
**Digitalization in drive technology**

Getting started in drive technology digitalization is very easy. We offer suitable digitalization solutions for low-voltage motors and low-voltage converters for every phase in the life cycle of a machine or plant. Our portfolio extends from the digital to the real drive train. Thanks to continuous integration, it is possible to start today in one area with little effort – and use the information acquired elsewhere tomorrow.

www.siemens.com/digital-drivetrain

More information

Further information about SINAMICS Drive Software is available on the internet at:
www.siemens.com/sinamics-drive-software

System overview

SINAMICS Drive Software > Motor Control Functions > "SINAMICS Motor Control Extended" for SINAMICS G220

Overview

Motor Control Functions				
Motor Control Functions				
Control philosophy				
Drives	SINAMICS S Multi-axis			
	SINAMICS G			SINAMICS S Single-axis
Control mode	Vector Control			Servo Control
	Standard Drive Control	Dynamic Drive Control	Expert Mode	<ul style="list-style-type: none"> Special closed-loop control for highest dynamics servo motor applications Especially important for machine tool applications
	<ul style="list-style-type: none"> Pumps, fans and compressors with flow characteristic Blasting technology Mills, mixers, kneaders, crushers, agitators Horizontal conveyor technology Basic spindles 	<ul style="list-style-type: none"> Demanding applications with high utilization of the motor/converter Pumps and compressors with displacement machines Extruders Centrifuges Vertical conveyor technology 	<ul style="list-style-type: none"> All applications All setting options are available 	
Required data	Rated speed and rated current	Rated speed, rated current and rated power	Depending on commissioning routine	Depending on commissioning routine
Focus	Easy & fast commissioning for the untrained user	Simplified commissioning for most applications	Maximum performance for the expert user	Maximum performance for the expert user

Motor control modes

The control methods are the core of the entire converter firmware. They are responsible for optimum movement of the connected motor and the attached machines. The better the control functions, the faster, better and more smoothly the machine operates, thereby significantly enhancing the quality of the production output.

Open loop control

The U/f open-loop control characteristic is the simplest way to control an induction motor. Several different characteristics, e. g. linear or parabolic, can be configured. In addition, basic functions like slip compensation, voltage boost or resonance damping are supported.

Universal closed-loop control (Vector Control)

The vector control emulates the motor as precisely as possible to obtain the best results regarding control precision and control quality.

For most applications and motors, the closed-loop vector control is the perfect choice. It is optimized for both Siemens and 3rd party motors.

Unknown motors – regardless of the technology (induction, synchronous reluctance, permanent magnet synchronous) – can be identified and commissioned easily.

The vector control is characterized by features like

- Best speed accuracy
- Best speed ripple
- Best torque accuracy
- Best torque ripple
- Optimized for control with or without encoder

Closed-loop control for highest dynamics (Servo Control)

In the servo control mode, the connected motor is emulated in a vector model based on its equivalent circuit diagram data. Consequently, the servo control constitutes a field-oriented control. In contrast to vector control, the vector model is optimized according to other criteria in servo control. In favor of achieving a high dynamic performance, a small deterioration in the control accuracy and control quality is accepted.

Special features of the servo control include

- Maximum computing speed
- Shortest sampling times
- Maximum dynamic performance
- High output frequencies
- Preferably used with permanent magnet synchronous motors with encoder for the appropriate dynamic performance

General control loop structures

Both servo and vector control share some common used control loop structures:

- Extended brake control. It allows complex brake controls, such as for motor holding brakes and service brakes.
- Setpoint channel. It is the link between the setpoint source and the motor control. The converter has a special feature that supports simultaneous input of two setpoints. Generation and subsequent modification of the total setpoint (influencing the direction, skip frequency, up/down ramp) take place in the setpoint channel.
- Command sources. Different sources of command usually result from the requirements to operate a drive from different places (on-site/remote), in different situations (standard/emergency mode) and/or different operating. The signal interconnection allows to configure and combine the command and setpoint sources completely individually.
- Limiters or limits are used to constrain input and/or output variables as appropriate to the connected machine; this means that not all positioning variables are used over their full range but are limited judiciously to enhance the safety and quality of the production process.
- Pulse frequency & modulation. Several different pulse frequencies possible to adjust the drive to the application including asynchronous pulse frequencies to minimize derating and mechanical resonances. In addition, wobbling is available to generate a more pleasant acoustic experience.

Overview

The software option SINAMICS Motor Control Extended for SINAMICS G220 enables high-performance encoderless closed-loop control of synchronous reluctance motors from standstill, by enabling pulse technique at very low speeds.

Main benefits

- Reduces commissioning time and effort (less configuration, tuning and wiring)
- Saves energy due to permanent operation in closed-loop vector control
- Saves cost for encoder, cable, installation, spares, etc.
- Allows continuous operation at near zero speeds including torque control
- Improves system stability and robustness
- Improves drive dynamic performance
- Improves reliability and availability by reducing system complexity

Example 1: Low speeds, robustness and energy efficiency

The following diagram shows a measured load cycle. In the low speed range, the software option SINAMICS Motor Control Extended leads to significant reduced currents and therefore increased energy efficiency. Also, continuous operation with high loads is possible near zero speed.

When medium speeds are reached (in diagram: rectangle), the control switches from the pulse technique to standard sensorless vector control.

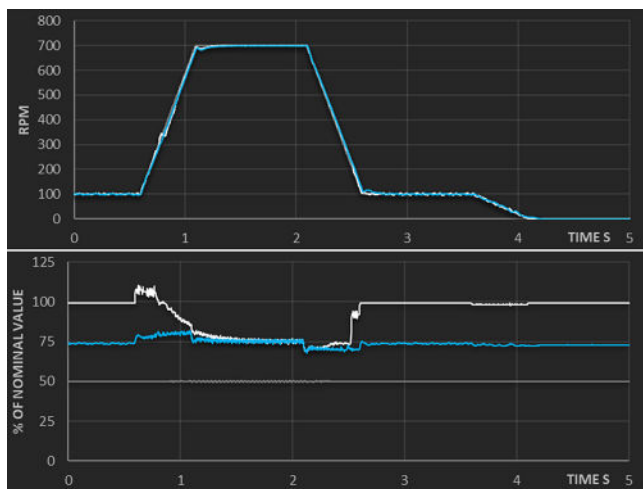

Example 2: Dynamic behavior

In the following measurement, a sinusoidal signal was used to demonstrate the dynamic performance of the pulse technique. The sinusoidal signal is reproduced perfectly with the pulse technique while maintaining a relatively low current compared to the standard sensorless control near zero speed. For higher sinusoidal frequencies, the standard control would not be able to work.

This shows perfectly that with the software option SINAMICS Motor Control Extended, also high dynamic applications that need fast reaction times at low speeds without ramps are possible.

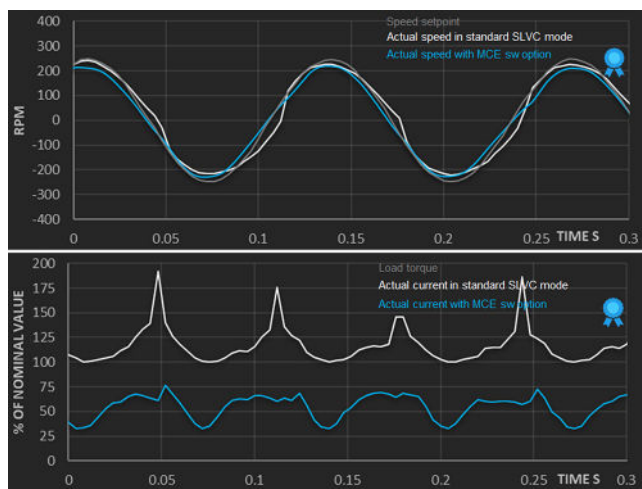

In which cases should SINAMICS Motor Control Extended be used?

With synchronous reluctance motor drive

- the application requires frequent or long or even permanent operation at very low speeds during operation cycle and/or precise torque control from 0 r/min is required (e. g. winders, mixers, extruders).
- If the load peak at start is difficult to predict or changes dynamically and/or positioning in the application is required (e. g. logistics, cranes, hoists).
- If the drive dynamic performance is critical, requiring operation with no or very short ramps in closed-loop (e. g. servo pumps).
- If the motor works in harsh conditions or it is impossible to use an encoder (dust, heavy vibrations, mechanical restrictions) (e. g. heavy industry).

SD card



Selection and ordering data

Description	Article No.
Delivery with SD card, 8 GB	
SINAMICS Motor Control Extended (license)	6SL5970-0AA00-0AA0-Z H01
With firmware V6.2 and SINAMICS Motor Control Extended (license)	6SL4170-1GC00-0AA0-Z H01
Delivery in electronic form, eCOL (without SD card)	6SL5977-0AA00-1DA0
SINAMICS Motor Control Extended (license)	

System overview

SINAMICS Drive Software > Technology Functions

Overview

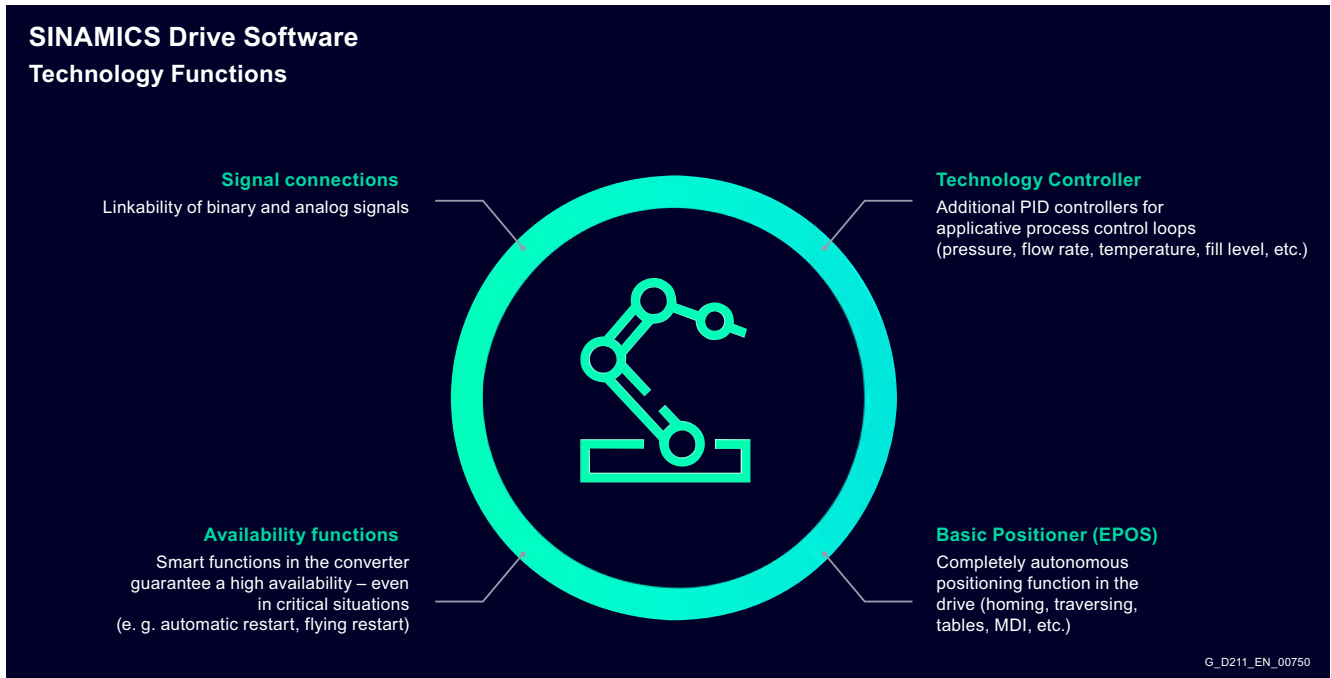

Signal connections

Create new functions by intelligently interconnecting sub-functions. Signal Connect gives you the flexibility you need to configure customized solutions to meet your needs.

Basic Positioner

The basic positioner provides powerful and precise positioning functions. Due to its flexibility and adaptability, the basic positioner (EPOS) can be used for a wide range of positioning tasks.

The functions are easy to use during both commissioning and operation, and the comprehensive monitoring functions are very powerful.

As a consequence, many applications can be implemented without having to use external position controls.

Technology Controller

The technology controller is implemented as a PID controller for performing all kinds of process control tasks. It can be used to control the line pressure, fill level, temperature, flow or tension control, or load balancing etc.

Availability functions

Smart functions in the converter guarantee a high availability – even in critical situations. These functions are e. g. automatic restart, flying restart, kinetic buffering, overvoltage limitation, keep running mode and emergency operation mode.

Function

Signal interconnection

The SINAMICS drive system allows input and output signals of different SINAMICS Drive Software functions to be interconnected with one another. In addition to setting parameters, the ability to interconnect signals is an additional option of adapting SINAMICS Drive Software functions to address the particular application. Signal connection enables flexible adaptation of SINAMICS to a wide range of the customer requirements.

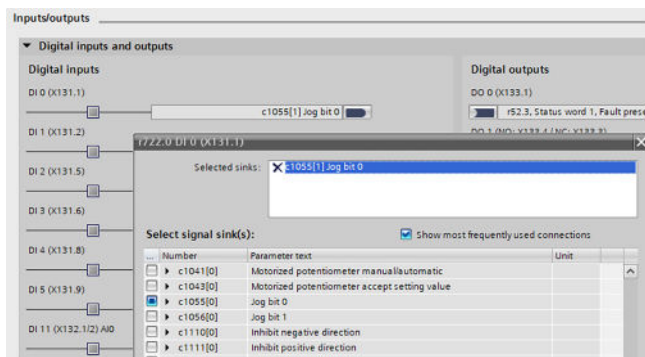

Technology Controller

The integrated technology controller in SINAMICS Drive Software enables precise control of process variables such as pressure, temperature, level and flow. With a wide range of additional functions, the technology controller offers an optimum solution for your individual requirements:

Setpoint specification: Flexible selection between analog value and fixed setpoint in order to achieve the desired objective precisely.

Setpoint channel: With functions such as scaling, ramp-function generator and filter, you have full control over the desired setpoint.

Actual value channel: Use filtering, limiting and signal conditioning for precise acquisition and processing of the actual value.

PID controller: Optimize the performance of your control system by individually setting the D component, blocking the I component and adjusting the control sense.

Enabling and limiting the controller output: Control the output of the controller as required and set individual limits to ensure the stability of your processes.

Fault reaction: Our PID controller reacts to errors that occur, ensuring reliable and safe control of your process parameters.

The technology controller not only offers precision, but also user-friendliness and adaptability. Rely on proven technology for optimum results in your applications!

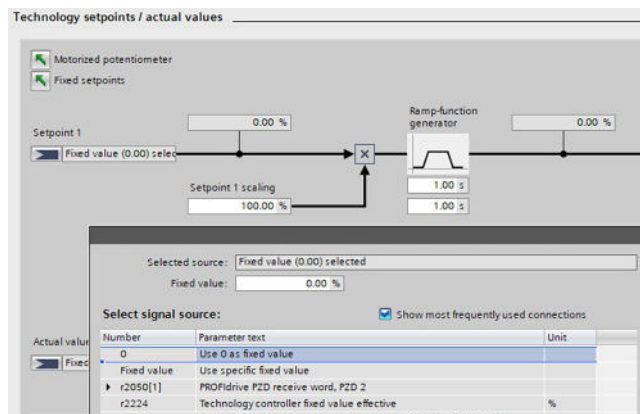

Availability functions

The following smart functions are available to increase availability:

Automatic restart:

Use the powerful automatic restart function in the SINAMICS drive system to ensure a reliable and automatic restart. This innovative function enables seamless power recovery, especially after a power failure.

Any faults that occur are automatically acknowledged and the drive restarts automatically. This functionality goes beyond mains faults and can be used flexibly for any fault shutdowns. The automatic restart function therefore offers a comprehensive solution for critical situations.

Thanks to its adaptability and reliability, this function minimizes downtimes and increases the overall availability of the drive system.

Flying restart:

Experience the impressive "flying restart" function – an intelligent solution that allows your motor module to seamlessly switch to a motor that may already be rotating after it has been switched on. This advanced function can be activated both in operation with and without an encoder and offers maximum application versatility.

A practical example illustrates the performance of this function: After a power failure, a fan drive can be quickly synchronized with the running fan motor again thanks to the "flying restart" function. This enables operation to be resumed as quickly as possible and significantly minimizes downtimes.

Integrate the "flying restart" function into your drive systems and benefit from reliable, flexible and efficient motor control – exactly when it matters.

System overview

SINAMICS G220 built-in and wall-mounted units

1

Overview



Example: SINAMICS G220 built-in units, degree of protection IP20 / UL Open Type, frame sizes FSA, FSB, FSC, FSD1, FSD2 and FSE



Example: SINAMICS G220 wall-mounted units, degree of protection IP55 / UL Type 12, version without a maintenance switch, frame sizes FSB, FSC, FSD1, FSD2 and FSE

The SINAMICS G220 built-in and wall-mounted units are efficient, secure, and future-proof frequency converters that have been specifically developed for high-performance applications in manufacturing, process industries, and marine.

This converter series sets itself apart, especially as a result of its advanced motor control, high flexibility, very simple selection and operation, as well as fast commissioning, low harmonics, and long cable lengths. SINAMICS G220 built-in and wall-mounted units allow for increased availability of the plant or system and optimize energy efficiency.

SINAMICS G220 converter series provides a complete and seamless range of products:

- Voltage versions and power ratings:
 - 200 V to 240 V 3 AC: 0.55 kW to 30 kW (0.75 hp to 40 hp)
 - 380 V to 500 V 3 AC: 1.1 kW to 55 kW (1.5 hp to 40 hp)
 - 525 V to 690 V 3 AC (available soon)
- Degrees of protection (IP20 / UL Open Type and IP55 / UL Type 12)
- Clean Power to reduce line harmonics
 - 380 V to 500 V 3 AC: 7.5 kW to 55 kW
- Power ratings from 55 kW up to 1 MW available in the future

Overview



SINAMICS G220 starter kit incl. SINAMICS Smart Adapter

A SINAMICS G220 starter kit comprises a SINAMICS G220 converter (200 V or 400 V 3 AC; PROFINET / Modbus TCP/IP, EtherNet/IP) with SINAMICS Smart Adapter for Wi-Fi access to the integrated web server of the converter.

The delivery quantity is limited to three units per customer.

The SINAMICS G220 starter kits can be combined with the SIMATIC starter kits. In this way, simple drive tasks up to motion control applications can be quickly implemented.

Selection and ordering data

Description	Article No.
SINAMICS G220 starter kits SINAMICS G220 converter (3 AC, PROFINET / Modbus TCP/IP, EtherNet/IP) with SINAMICS Smart Adapter for Wi-Fi access to the integrated web server.	
<ul style="list-style-type: none"> • 200 V to 240 V 3 AC, IP20 / UL Open Type, 2.2 kW, FSA, without integrated line filter 	6SL4990-0AE10-0AA0
<ul style="list-style-type: none"> • 380 V to 500 V 3 AC, IP20 / UL Open Type, 4 kW, FSA, with integrated line filter Category C2 (removable) 	6SL4990-0AE11-0AA0
<ul style="list-style-type: none"> • 380 V to 500 V 3 AC, IP20 / UL Open Type, 7.5 kW, FSB, with integrated line filter Category C2 (removable), SINAMICS SDI Pro 5.5" handheld kit 	Available soon
<ul style="list-style-type: none"> • 380 V to 500 V 3 AC, IP55 / UL Type 12, 5.5 kW, FSB, with integrated line filter Category C2 (removable) 	Available soon
<ul style="list-style-type: none"> • 380 V to 500 V 3 AC, Clean Power, IP20 / UL Open Type, 7.5 kW, FSD1, with integrated line filter Category C2 (removable) 	Available soon
<ul style="list-style-type: none"> • 380 V to 500 V 3 AC, Clean Power, IP55 / UL Type 12, 15 kW, FSD1, with integrated line filter Category C2 (removable), SINAMICS SDI Pro 5.5" with SINAMICS IP55 panel mounting frame 	Available soon

System overview

Notes

1

SINAMICS G220 built-in and wall-mounted units



2/2	SINAMICS G220 built-in and wall-mounted units
2/2	Overview
2/6	Benefits
2/6	Integration
2/8	Dimensional drawings
2/10	Selection and ordering data
2/10	IP20/UL Open Type 200 ... 240 V 3 AC · 0.55 kW to 30 kW
2/12	IP20/UL Open Type 380 ... 500 V 3 AC · 1.1 kW to 55 kW
2/14	IP55/UL Type 12 200 ... 240 V 3 AC · 1.1 kW to 30 kW
2/16	IP55/UL Type 12 380 ... 500 V 3 AC · 1.1 kW to 55 kW
2/18	Clean Power/IP20/UL Open Type NEW 380 ... 500 V 3 AC · 7.5 kW to 55 kW
2/20	Supplementary system components for SINAMICS G220 built-in and wall-mounted units
2/21	Safety Integrated for SINAMICS G220
2/23	Supplementary system components
2/23	Option Modules
2/23	OM-DQ Option Module DRIVE-CLiQ
2/24	OM-IIoT Option Module IIoT
2/25	OM-SMT Option Module Safe Motor Temperature
2/26	Smart Drive Interfaces
2/27	SINAMICS SDI Standard
2/29	SINAMICS SDI Pro 5.5"
2/34	SINAMICS Smart Adapter
2/36	Encoder system connection
2/36	SMC20 Sensor Module Cabinet-Mounted
2/37	SMC30 Sensor Module Cabinet-Mounted

Further information about SINAMICS G220

can be found on the internet at
www.siemens.com/sinamics-g220

More technical specifications

can be found on the internet at
[www.siemens.com/sinamics-g220/
documentation](http://www.siemens.com/sinamics-g220/documentation)

and concerning ordering and configuration
via the Siemens Product Configurator in
SiePortal:

[www.siemens.com/sinamics-g220/
configuration](http://www.siemens.com/sinamics-g220/configuration)

SINAMICS G220 built-in and wall-mounted units

Overview



Example: SINAMICS G220 built-in units, degree of protection IP20 / UL Open Type, frame sizes FSA, FSB, FSC, FSD1, FSD2 and FSE



Example: SINAMICS G220 wall-mounted units, degree of protection IP55 / UL Type 12, version without a maintenance switch, frame sizes FSB, FSC, FSD1, FSD2 and FSE

The SINAMICS G220 built-in and wall-mounted units are efficient, secure, and future-proof frequency converters that have been specifically developed for high-performance applications in manufacturing, process industries, and marine.

This converter series sets itself apart, especially as a result of its advanced motor control, high flexibility, very simple selection and operation, as well as fast commissioning, low harmonics, and long cable lengths. SINAMICS G220 built-in and wall-mounted units allow for increased availability of the plant or system and optimize energy efficiency.

SINAMICS G220 converter series provides a complete and seamless range of products:

- Voltage versions and power ratings:
 - 200 V to 240 V 3 AC: 0.55 kW to 30 kW (0.75 hp to 40 hp)
 - 380 V to 500 V 3 AC: 1.1 kW to 55 kW (1.5 hp to 40 hp)
 - 525 V to 690 V 3 AC (available soon)
- Degrees of protection (IP20 / UL Open Type and IP55 / UL Type 12)
- Clean Power to reduce line harmonics
 - 380 V to 500 V 3 AC: 7.5 kW to 55 kW
- Power ratings from 55 kW up to 1 MW available in the future

Overview

Enjoy a new efficiency level and let your technology do the work for you

The SINAMICS G220 is a compact and efficient converter solution for a wide range of applications. It offers highly efficient commissioning, diagnostics and maintenance thanks to the engineering tools.

SINAMICS web server for SINAMICS G220

Web server for efficient commissioning, diagnostics, maintenance and operator control and monitoring, any time, from anywhere.

SINAMICS SDI Standard (Smart Drive Interface)



The SINAMICS SDI Standard is a highly user-friendly Operator Panel for the SINAMICS G220. The SDI Standard supports newcomers and drive experts alike with essential tasks locally on the device. Thanks to its high-contrast 1.4" color display and membrane keyboard, the device can assist with diagnosing faults in plain text, operation and monitoring, and with maintenance and servicing of the converter on site.

SINAMICS SDI Pro 5.5" (Smart Drive Interface)



SINAMICS SDI Pro 5.5", Handheld

The SINAMICS SDI Pro 5.5" represents a powerful and user-friendly Operator Panel for SINAMICS G220. The SDI Pro supports both newcomers and drive experts. Thanks to its touch interface and high-contrast 5.5" color display, it goes hand-in-glove for commissioning, diagnostics, operator control and monitoring as well as on-site maintenance and servicing of converters.

The additional available options, such as the SINAMICS SDI Pro 5.5" handheld kit and SINAMICS SDI Pro 5.5" door mounting kit, extend the operating range of the device. With the SDI Pro 5.5" handheld kit, the device can be equipped with a rubber overshooth for mobile use. The SINAMICS SDI Pro 5.5" door mounting kit enables the SINAMICS SDI Pro to be installed in control cabinet doors.

SINAMICS Smart Adapter



SINAMICS Smart Adapter

SINAMICS Smart Adapter is a Wi-Fi solution for engineering, service and maintenance tasks with the next generation of SINAMICS converters. The adapter is designed to be plugged into and powered from the service interface (X127) on the converter.

SINAMICS Startdrive commissioning tool in TIA Portal

Integration via PROFINET communication, Modbus TCP or EtherNet/IP into a higher-level control system has never been so easy thanks to the full integration of SINAMICS G220 into the SINAMICS Startdrive commissioning tool in TIA Portal. In combination with SIMATIC S7-1500, the SINAMICS G220 drive with PROFINET communication is a harmonized and coordinated motion control solution in TIA Portal. The connection to the SINAMICS G220 converter is made via clock-synchronous PROFINET IRT and the safety connection (in case of faulty SIMATIC S7-1500F) directly via PROFIsafe. This approach reduces engineering times and increases productivity.

SINAMICS G220 built-in and wall-mounted units

Overview

More efficient and sustainable due to minimized harmonics



The SINAMICS G220 is the first choice for anyone seeking an energy efficient converter. The innovative **SINAMICS G220 Clean Power**¹⁾ effectively reduces line harmonics. With its revolutionary and integrated active infeed unit, harmonics are reduced to the minimum and the total harmonic current distortion is typically less than 5 %. No additional options are required to comply with IEC 61000-5-19 reducing the material footprint for a more sustainable industry.

In addition, the advanced hardware and software functions of SINAMICS G220 provide reliable motor control of high efficiency motors such as synchronous reluctance motors and permanent magnet synchronous motors.

SINAMICS G220 is designed for long cable lengths and it can reach to up to 150 m according to C2 EMC Category. Integrated DC link reactor is also available in all power ratings and a wide portfolio of energy saving functions.

Master tomorrow's challenges today with safe and secure technology

SINAMICS G220 provides Security Integrated functions increasing the level of data security to comprehensively protect industrial plants and systems from cyber attacks – from both inside and outside. SINAMICS G220 "Defense in Depth" security concept ensures and provides individual user management including access control along with secure communication between the variable frequency converter and the TIA Portal engineering system or web client. It reliably protects availability through Security Integrated functions.

Furthermore, this new variable frequency converter is equipped with Safety Integrated functions up to SIL3 (safety integrity level) and PL e (performance level) according to IEC 62061 and ISO 13849-1 standards. This means that the system and the machine comply with strict safety requirements.

Local safety concepts can be implemented by controlling the integrated safety functions via fail-safe terminals as well as integrated in the automation via fail-safe PROFIsafe communication profile.

The variable frequency converter is equipped with the following safety functions as standard:

- Safe Torque Off (STO)
- Safe Stop 1 time-controlled (SS1-t)
- Safe Motor Temperature (SMT) in combination with the optional OM-SMT Option Module Safe Motor Temperature → New functionality, which allows an easy integration of safe motor temperature monitoring for ATEX applications. Option module OM-SMT Safe Motor Temperature is required.

Extended safety functions can be simply added via the Safety Integrated Extended software option:

- Safe Stop 1 (SS1) with SBR/SAM
- Safely Limited Speed (SLS)
- Safe Direction (SDI)
- Safe Speed Monitor (SSM)

Thanks to the high degree of protection IP55 / UL Type 12 and the 3C3 coating on the electronics, the SINAMICS G220 is ready to work in harsh environments ensuring longer lifetimes and rugged operation.

In addition, SINAMICS G220 secures the availability of processes and machines thanks to the support of PROFINET media redundancy protocol and S2 system redundancy.



Example: SINAMICS G220, degree of protection IP55 / UL Type 12, version without a maintenance switch, frame size FSD1

Siemens EcoTech Profile (SEP) for SINAMICS G220

Siemens introduces a new label: Siemens EcoTech. It is an environmental declaration for products based on product-specific evaluations of sustainability relevant KPIs. To provide maximum transparency, the Siemens EcoTech Profile (SEP) were created for all Siemens EcoTech products.

It is a Siemens-created, standardized product data sheet which gives insight about the product performance in environmental relevant criteria as well as about interpretation and comparison of data against an existing norm, standard or predecessor product.

You can find more information on the internet at:

<https://support.industry.siemens.com/cs/ww/en/ps/28308/cert?ci=5702>
www.siemens.com/SiemensEcoTech



¹⁾ SINAMICS G220 Clean Power with degree of protection IP20/UL Open Type is released for 380 ... 500 V 3 AC in power range 7.5 kW to 55 kW. SINAMICS G220 Clean Power with degree of protection IP55/UL Type 12 is available soon.

Overview

Future-proof your applications by accelerating the digital transformation

SINAMICS G220 is ready for digitalization in every phase of the life cycle: Design – Realize – Optimize.

In the design phase, the **SINAMICS G220 digital twin** integrated in SINAMICS Startdrive commissioning tool in TIA Portal via **DriveSim Engineer** makes it possible to virtualize, simulate and test the drive behavior, identify issues and make changes ahead of time in order to speed up the development of machines and plants.

During the realization phase, our powerful digitalization engineering tools, for example SINAMICS Startdrive commissioning tool in TIA Portal and Drive Connector SINAMICS, speed up the implementation, commissioning and connectivity of SINAMICS G220. Thanks to the IIoT (Industrial Internet of Things) option module together with the edge application Drive Connector SINAMICS, high frequency data can be transferred from the drive to the Industrial Edge and to the cloud. Finally, in the optimization phase, the acquired data can be analyzed on Industrial Edge or in the Cloud for example with the application Drivetrain Analyzer ¹⁾. The result is improved machine capacity utilization, higher availability, enhanced productivity and optimized energy efficiency.

Attain a high level of flexibility and seamlessly integrate your solutions globally

SINAMICS G220 offers a high-performance drive solution that can be matched to the customer-specific requirements using the wide range of available option modules and software functions.

- Different option modules can be easily plugged beneath the converter. This allows you to customize the SINAMICS G220 by adding DRIVE-CLiQ interface, ATEX certified sensor temperature connection and the gateway to digitalization via the IIoT module. Same flexibility concept applies to the communication of the converter. The communication modules can be simply exchanged to meet the requirements of the standard field-buses. In the first step, PROFINET, Modbus TCP and EtherNet/IP communication protocols are available. PROFIBUS and Modbus RTU will be added to the portfolio soon.
- The SINAMICS Drive Software ensures that SINAMICS G220 frequency converters operate smoothly and reliably. It offers an easy to expand comprehensive software portfolio and enables high flexibility for a wide range of applications. For example, SINAMICS Motor Control Extended for an optimal motor control near standstill, or an extension of the Safety Integrated functions with Safety Extended option.

The SINAMICS G220 is compliant with all the global standards. This frequency converter offers a wide range of power ratings based on a seamlessly integrated system, for all common voltages, line supplies as well as degrees of protection IP20 / UL Open Type and IP55 / UL Type 12.

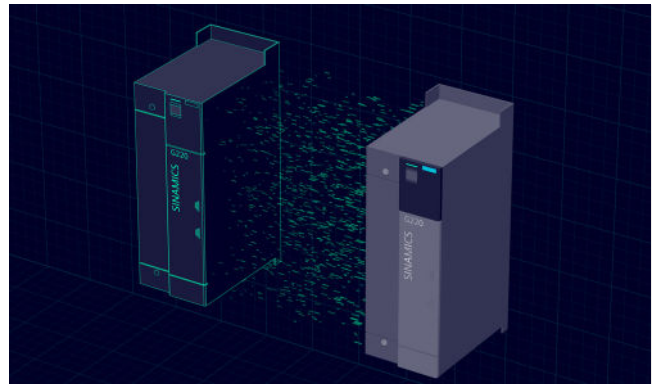

Option Modules



SINAMICS G220 OM-DQ Option Module DRIVE-CLiQ



SINAMICS G220 OM-IIoT Option Module IIoT



SINAMICS G220 OM-SMT Option Module Safe Motor Temperature

¹⁾ Available soon.

SINAMICS G220 built-in and wall-mounted units

Overview

Extended warranty

For SINAMICS G220, Siemens offers an optional extended warranty of up to 5½ years via **Service Protect**:

- Free for the first 6 months after registering the product at: <https://myregistration.siemens.com>
- Subject to a charge for a further 3 or 5 years of extended warranty.
You can find detailed information here: <https://support.industry.siemens.com/cs/ww/en/sc/4842>

You can find the correct Service Protect product number for your SINAMICS G220 converter using our simple configurator www.siemens.com/serviceprotect

Concerning standard warranty please ask your partner at Siemens.

Your partner can be found in our Personal Contacts Database at: www.siemens.com/automation-contact

2

Benefits

- **Reduce energy consumption** with the ultimate Clean Power technology in low harmonics and high efficiency motors control.
- **Protect know-how** and ensure safe personnel, machines and systems with Safety Integrated and Security Integrated.
- **Accelerate time-to-market** by using the digital twin of the drive during design, test and optimization phase.
- **Boost productivity** thanks to easy commissioning, diagnostics, service and the integration into TIA Portal.
- **Safeguard system availability** even in harsh environments thanks to S2 redundancy, IP55 / UL Type 12, ATEX-certified input and Edge and Cloud connectivity.
- **Maximize system flexibility** thanks to a configurable drive solution via hardware and software options.

Integration

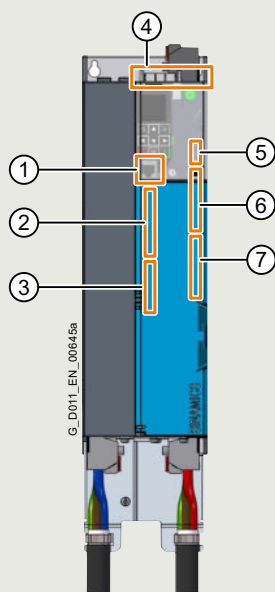

- ① X127 Service interface (e. g. connection for the operation unit)
- ② X132 Analog inputs, analog outputs and temperature sensors
- ③ X133 Digital outputs
- ④ X1xx Communications module
- ⑤ X124 External power supply
- ⑥ X130 Fail-safe digital input, fail-safe digital output
- ⑦ X131 Digital inputs

Example: SINAMICS G220, Interface overview, degree of protection IP20 / UL Open Type

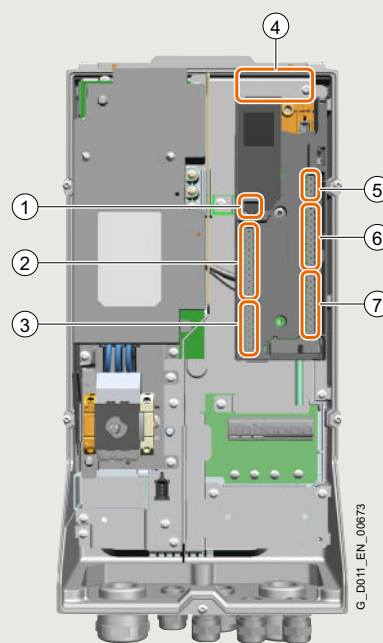

- ① X127 Service interface (e. g. connection for the operation unit)
- ② X132 Analog inputs, analog outputs and temperature sensors
- ③ X133 Digital outputs
- ④ X1xx Communications module
- ⑤ X124 External power supply
- ⑥ X130 Fail-safe digital input, fail-safe digital output
- ⑦ X131 Digital inputs

Example: SINAMICS G220, Interface overview, degree of protection IP55 / UL Type 12

SINAMICS G220 built-in and wall-mounted units

Integration

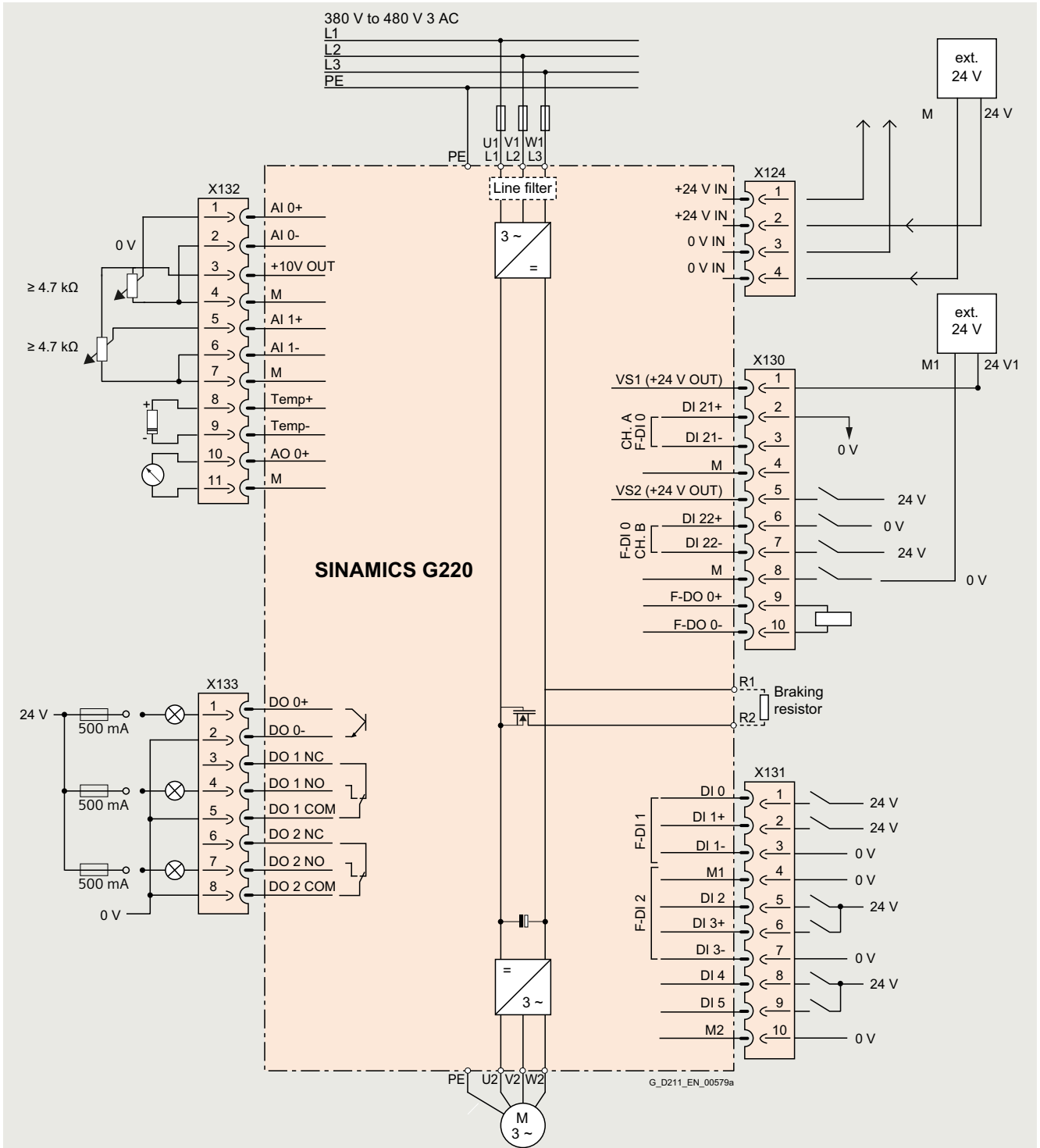

Example: SINAMICS G220, Connection diagram

SINAMICS G220 built-in and wall-mounted units

Dimensional drawings

SINAMICS G220 degree of protection IP20 / UL Open Type

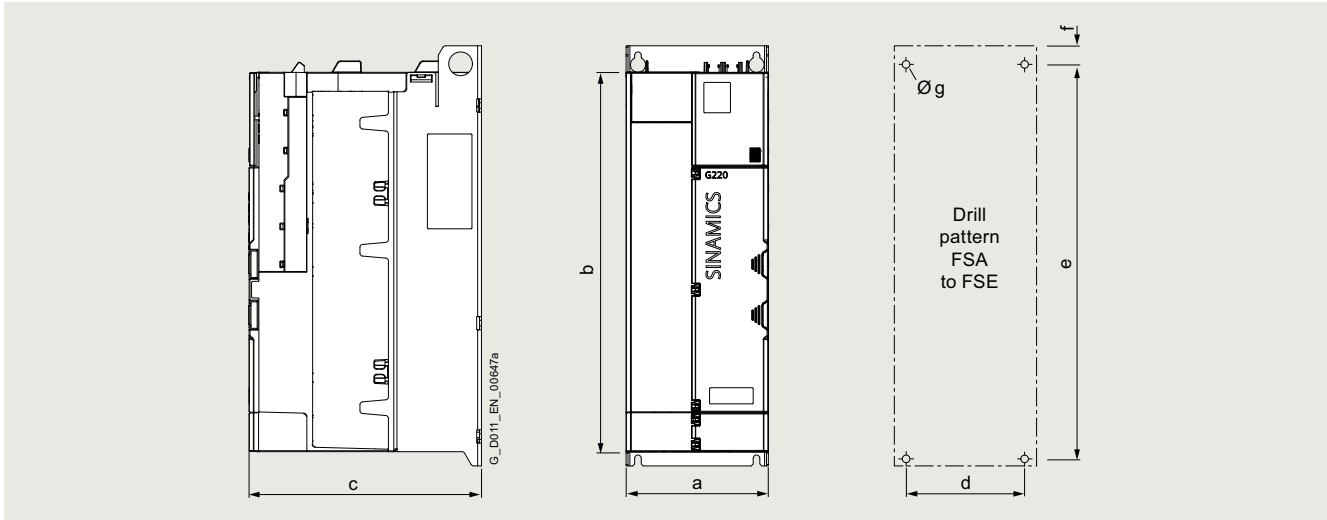

Principle dimension drawing and drill pattern for SINAMICS G220 degree of protection IP20 / UL Open Type

Frame size	Dimensions in mm (inches)			Drilling dimensions in mm (inches)				Mounting With screws (plus washers and nuts)	Cooling clearance in mm (inches)		Minimal mounting clearance (inches) front
	a (width)	b (height) ¹⁾	c (depth)	d	e	f	g		top	bottom	
FSA	73 (2.88)	250 (9.84)	219 (8.63)	50 (1.97)	272 (10.71)	10 (0.39)	11 (0.43)	4 × M4	85 (3.35)	85 (3.35)	10 (0.39)
FSB	85 (3.35)	355 (13.98)	219 (8.63)	50 (1.97)	375 (14.76)	8.7 (0.34)	11 (0.43)	4 × M5	85 (3.35)	108 (4.26)	10 (0.39)
FSC	125 (4.92)	355 (13.98)	219 (8.63)	100 (3.94)	375 (14.76)	10 (0.39)	11.5 (0.45)	4 × M5	85 (3.35)	149 (5.87)	10 (0.39)
FSD1	150 (5.91)	400 (15.75)	256 (10.09)	125 (4.92)	425 (16.73)	10 (0.39)	16 (0.63)	4 × M6	90 (3.55)	160 (6.30)	10 (0.39)
FSD2	200 (7.87)	442 (17.41)	256 (10.09)	175 (6.89)	475 (18.70)	10 (0.39)	16 (0.63)	4 × M6	90 (3.55)	160 (6.30)	10 (0.39)
FSE	250 (9.84)	520 (20.47)	256 (10.09)	225 (8.86)	550 (21.66)	10 (0.39)	16 (0.63)	4 × M6	90 (3.55)	193 (7.60)	10 (0.39)

¹⁾ Height is extended by the shield plate – refer to the equipment user manual for specific values

Dimensional drawings

SINAMICS G220 degree of protection IP55 / UL Type 12

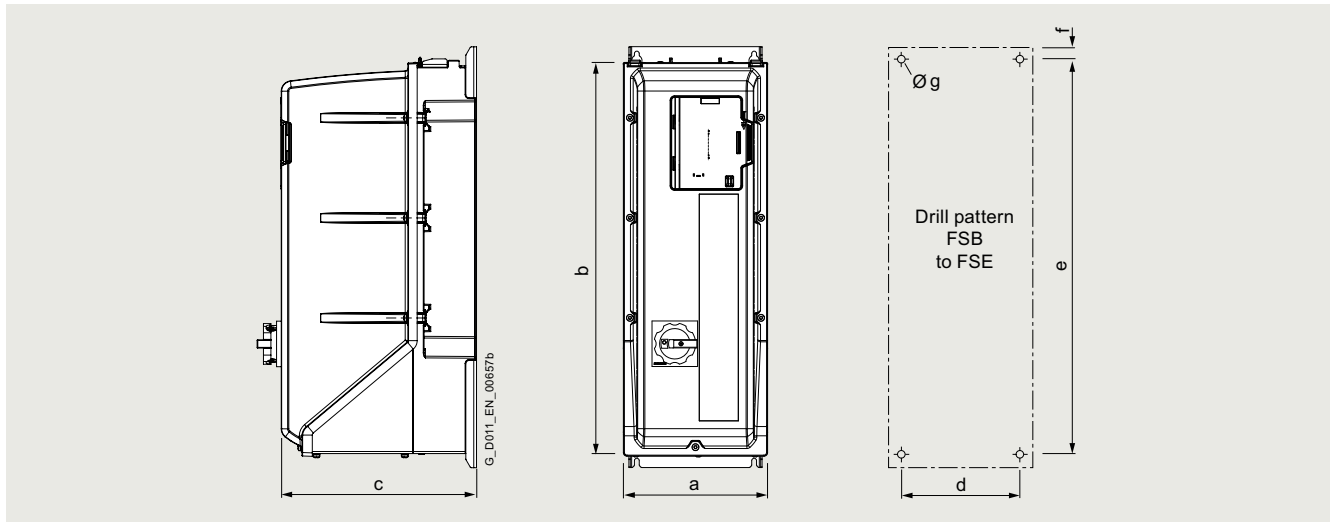

Principle dimension drawing and drill pattern for SINAMICS G220 degree of protection IP55 / UL Type 12

Frame size	Dimensions in mm (inches)			Drilling dimensions in mm (inches)				Mounting With screws (plus washers and nuts)	Cooling clearance in mm (inches)	
	a (width)	b (height)	c (depth)	d	e	f	g		top	bottom
FSB	225 (8.87)	415 (16.35)	265 (10.44)	170 (6.70)	435 (17.14)	8 (0.32)	13 (0.51)	4 × M4	103 (4.06)	103 (4.06)
FSC	245 (9.65)	460 (18.12)	290 (11.43)	200 (7.88)	480 (18.91)	10 (0.39)	16 (0.63)	4 × M5	115 (4.53)	115 (4.53)
FSD1	209 (8.23)	571 (22.50)	324 (12.77)	170 (6.70)	590 (23.25)	10 (0.39)	15 (0.59)	4 × M5	143 (5.63)	143 (5.63)
FSD2	270 (10.64)	650 (25.61)	329 (12.96)	225 (8.87)	675 (26.60)	14 (0.55)	14 (0.55)	4 × M6	163 (6.42)	163 (6.42)
FSE	327 (12.88)	778 (30.65)	390 (15.37)	285 (11.23)	800 (31.54)	14 (0.55)	14 (0.55)	4 × M6	195 (7.68)	195 (7.68)

SINAMICS G220 built-in and wall-mounted units

Clicking to SiePortal

6SL3255-0AA00-5AA0



IP20/UL Open Type · 200 ... 240 V 3 AC · 0.55 kW to 30 kW (0.75 hp to 40 hp)

Selection and ordering data

SINAMICS G220 built-in and wall-mounted units → Configuration with power components (see right page)

Rated power				Rated output current				Rated input current		Frame size	SINAMICS G220 without integrated line filter
Low overload (LO)		High overload (HO)		Low overload (LO)		High overload (HO)		Low overload (LO)			
Acc. to IEC	Acc. to NEC	Acc. to IEC	Acc. to NEC	Acc. to IEC	Acc. to NEC	Acc. to IEC	Acc. to NEC	Acc. to IEC	Acc. to NEC		
230 V	240 V	230 V	240 V	230 V	240 V	230 V	240 V	230 V	240 V		
kW	hp	kW	hp	A	A	A	A	A	A	Article No.	

200 ... 240 V 3 AC · Rated pulse frequency 4 kHz · Input frequency 50/60 Hz (47 ... 63 Hz)

0.55	0.75	0.37	0.5	3.9	3.2	2.9	2.2	3.2	3.0	FSA	6SL4112-0 ■ A 05 - 0 ■ F 0
0.75	1	0.55	0.75	4.7	4.2	3.9	3.2	3.9	3.7	FSA	6SL4112-0 ■ A 06 - 0 ■ F 0
1.1	1.5	0.75	1	6.5	6.0	4.7	4.2	5.4	5.1	FSA	6SL4112-0 ■ A 08 - 0 ■ F 0
1.5	2	1.1	1.5	8.5	6.8	6.5	6.0	7.1	6.4	FSA	6SL4112-0 ■ A 10 - 0 ■ F 0
2.2	3	1.5	2	11	9.6	8.5	6.8	10.1	9.3	FSA	6SL4112-0 ■ A 11 - 0 ■ F 0
3	4	2.2	3	14.5	12.4	11	9.6	13.1	11.9	FSB	6SL4112-0 ■ A 12 - 0 ■ F 0
4	5	3	4	19	15.2	14.5	12.4	17.7	14.7	FSB	6SL4112-0 ■ A 13 - 0 ■ F 0
5.5	7.5	4	5	27	22	19	15.2	21.7	20.1	FSC	6SL4112-0 ■ A 15 - 0 ■ F 0
7.5	10	5.5	7.5	34	28	27	22	29.5	26.6	FSC	6SL4112-0 ■ A 16 - 0 ■ F 0
11	15	7.5	10	46	42	40	28	41.8	39.5	FSD2	6SL4112-0 ■ A 17 - 0 ■ F 0
15	20	11	15	63	54	46	42	53.9	49.7	FSD2	6SL4112-0 ■ A 18 - 0 ■ F 0
18.5	25	15	20	75	68	63	54	66.5	62.5	FSD2	6SL4112-0 ■ A 20 - 0 ■ F 0
22	30	18.5	25	90	80	75	68	76.0	72.1	FSE	6SL4112-0 ■ A 21 - 0 ■ F 0
30	40	22	30	112	104	90	80	103.2	96.1	FSE	6SL4112-0 ■ A 23 - 0 ■ F 0

Article No. supplements

Degree of protection	Cooling	Coating acc. to IEC 60721-3-3: 2002	Housing				
IP20/UL Open Type	Internal	Class 3C2 Class 3C3 ¹⁾	Standard	C	D		
Hardware configuration							
Standard						A	
Line filter							
Without integrated line filter							0
Additional hardware option							
Without hardware option or with more than one hardware option (see Special versions)							A
OM-DQ Option Module DRIVE-CLiQ							B
OM-ILoT Option Module ILoT ¹⁾							E
OM-SMT Option Module Safe Motor Temperature							F
Communication							
PROFINET, Modbus TCP and EtherNet/IP							F
Special versions							
Only for selection of more than one hardware option (Additional hardware option = "A")							
OM-DQ Option Module DRIVE-CLiQ							6SL4112-0 ■ ... - A 0 - Z ... + ... + ...
OM-ILoT Option Module ILoT ¹⁾							T01
OM-SMT Option Module Safe Motor Temperature							T04
							T05

More information

Further technical specifications and documentation are available on the internet at:
www.siemens.com/sinamics-g220/documentation
 and concerning ordering and configuration via the Siemens Product Configurator in SiePortal:
www.siemens.com/sinamics-g220/configuration

¹⁾ Available soon.

Clicking to SiePortal

6SL3255-0AA00-5AA0



SINAMICS G220 built-in and wall-mounted units

IP20/UL Open Type · 200 ... 240 V 3 AC · 0.55 kW to 30 kW (0.75 hp to 40 hp)

2

Line-side components					DC link components	Load-side power components		
Line reactors	Recommended line-side overcurrent protection devices				Braking resistors	Output reactors	dv/dt filters plus VPL	
	More information at: www.siemens.com/sinamics-g220/ocpd							
	Fuses IEC-compliant		Fuses UL/cUL-compliant Rated voltage 600 V AC					
	Current		Fuse type	Current				
Article No.	A	Article No.	Class/Article No.	A	Article No.	Article No.	Article No.	
A DC line reactor is integrated – therefore no line reactor is required.	6	3NA3801	J	6	JJY:023151720007	–	–	
	10	3NA3803	J	8		–	–	
	10	3NA3803	J	10		–	–	
	16	3NA3805	J	12		–	–	
	16	3NA3805	J	15		–	–	
	20	3NA3807	J	20		JJY:023163720018	–	–
	32	3NA3812	J	30		–	–	
	40	3NA3817	J	40		JJY:023433720001	–	–
	50	3NA3820	J	50		–	–	
	80	3NA3824	J	70		JJY:023422620002	–	–
	100	3NA3830	J	90		–	–	
	100	3NA3830	J	110		–	–	
	125	3NA3832	J	125		JJY:023423320001	–	–
160	3NA3836	J	150	–	–			

Ordering examples

Basic selection

SINAMICS G220 converters · degree of protection IP20/UL Open Type · 200 ... 240 V 3 AC, 15 kW · without integrated line filter

Example 1: 6SL4112-0 C A 18- 0 A F 0 -Z

Example 2: 6SL4112-0 D A 18- 0 B F 0

Degree of protection	Cooling	Coating acc. to IEC 60721-3-3: 2002	Housing
IP20/UL Open Type	Internal	Class 3C2 Class 3C3 ¹⁾	Standard

Article No. supplements

Hardware configuration
Standard

Line filter
Without integrated line filter

Additional hardware option
Without hardware option or with more than one hardware option (see Special versions)

OM-DQ Option Module DRIVE-CLiQ
OM-ILoT Option Module ILoT ¹⁾
OM-SMT Option Module Safe Motor Temperature

Communication
PROFINET, Modbus TCP and EtherNet/IP

Special versions
OM-DQ Option Module DRIVE-CLiQ
OM-ILoT Option Module ILoT ¹⁾
OM-SMT Option Module Safe Motor Temperature

Complete Article No.
with "-Z" and order codes

Order codes:
T01
T04
T05

6SL4112-0 C A 18- 0 A F 0 -Z T01 + T04 + T05

6SL4112-0 D A 18- 0 B F 0 T01 + T04 + T05

¹⁾ Available soon.

SINAMICS G220 built-in and wall-mounted units

Clicking to SiePortal

6SL3255-0AA00-5AA0



IP20/UL Open Type · 380 ... 500 V 3 AC · 1.1 kW to 55 kW (1.5 hp to 75 hp)

Selection and ordering data

SINAMICS G220 built-in and wall-mounted units → Configuration with power components (see right page)

Rated power		Rated output current				Rated input current		Frame size	SINAMICS G220 without integrated line filter	SINAMICS G220 with integrated line filter		
Low overload (LO)		High overload (HO)		Low overload (LO)		High overload (HO)		Low overload (LO)		High overload (HO)		
Acc. to IEC	Acc. to NEC	Acc. to IEC	Acc. to NEC	Acc. to IEC	Acc. to NEC	Acc. to IEC	Acc. to NEC	Acc. to IEC	Acc. to NEC	Acc. to IEC	Acc. to NEC	
400 V	480 V	400 V	480 V	400 V	480 V	400 V	480 V	400 V	480 V	400 V	480 V	
kW	hp	kW	hp	A	A	A	A	A	A	Article No.	Article No.	
380 ... 500 V 3 AC · Rated pulse frequency 4 kHz · Input frequency 50/60 Hz (47 ... 63 Hz)												
1.1	1.5	0.75	1	3.9	3.0	2.9	2.1	3.3	3.0	FSA	6SL4113-0 ■ A 08 - 0 ■ F 0	6SL4113-0 ■ A 08 - 2 ■ F 0
1.5	2	1.1	1.5	4.7	3.4	3.9	3.0	4.1	3.7	FSA	6SL4113-0 ■ A 10 - 0 ■ F 0	6SL4113-0 ■ A 10 - 2 ■ F 0
2.2	3	1.5	2	6.5	4.8	4.7	3.4	5.6	4.9	FSA	6SL4113-0 ■ A 11 - 0 ■ F 0	6SL4113-0 ■ A 11 - 2 ■ F 0
3	4	2.2	3	8.5	6.2	6.5	4.8	7.3	6.1	FSA	6SL4113-0 ■ A 12 - 0 ■ F 0	6SL4113-0 ■ A 12 - 2 ■ F 0
4	5	3	4	11	7.6	8.5	6.2	9.6	7.3	FSA	6SL4113-0 ■ A 13 - 0 ■ F 0	6SL4113-0 ■ A 13 - 2 ■ F 0
5.5	7.5	4	5	14.5	11	11	7.6	12.9	11.0	FSB	6SL4113-0 ■ A 15 - 0 ■ F 0	6SL4113-0 ■ A 15 - 2 ■ F 0
7.5	10	5.5	7.5	19	14	14.5	11	17.3	14.0	FSB	6SL4113-0 ■ A 16 - 0 ■ F 0	6SL4113-0 ■ A 16 - 2 ■ F 0
11	15	7.5	10	27	21	19	14	23.3	19.6	FSC	6SL4113-0 ■ A 17 - 0 ■ F 0	6SL4113-0 ■ A 17 - 2 ■ F 0
15	20	11	15	34	27	27	21	31.3	25.4	FSC	6SL4113-0 ■ A 18 - 0 ■ F 0	6SL4113-0 ■ A 18 - 2 ■ F 0
18.5	25	15	20	40	34	34	27	37.8	31.6	FSD1	6SL4113-0 ■ A 20 - 0 ■ F 0	6SL4113-0 ■ A 20 - 2 ■ F 0
22	30	18.5	25	46	40	40	34	44.9	37.5	FSD1	6SL4113-0 ■ A 21 - 0 ■ F 0	6SL4113-0 ■ A 21 - 2 ■ F 0
30	40	22	30	63	52	46	40	59.9	49.8	FSD2	6SL4113-0 ■ A 23 - 0 ■ F 0	6SL4113-0 ■ A 23 - 2 ■ F 0
37	50	30	40	75	65	63	52	72.6	59.9	FSD2	6SL4113-0 ■ A 24 - 0 ■ F 0	6SL4113-0 ■ A 24 - 2 ■ F 0
45	60	37	50	90	77	75	65	86.7	71.3	FSE	6SL4113-0 ■ A 26 - 0 ■ F 0	6SL4113-0 ■ A 26 - 2 ■ F 0
55	75	45	60	112	96	90	77	105.9	88.3	FSE	6SL4113-0 ■ A 27 - 0 ■ F 0	6SL4113-0 ■ A 27 - 2 ■ F 0

Article No. supplements

Degree of protection	Cooling	Coating acc. to IEC 60721-3-3: 2002	Housing	Order codes	
IP20/UL Open Type	Internal	Class 3C2 Class 3C3 ¹⁾	Standard	C D	C D
Hardware configuration				A	A
Standard				A	A
Line filter				0	2
Without integrated line filter				0	2
With integrated line filter Category C2				0	2
Additional hardware option				A B E F	A B E F
Without hardware option or with more than one hardware option (see Special versions)				A B E F	A B E F
OM-DQ Option Module DRIVE-CLiQ				A	A
OM-ILoT Option Module ILoT ¹⁾				B	B
OM-SMT Option Module Safe Motor Temperature				E	E
Communication				F	F
PROFINET, Modbus TCP and EtherNet/IP				F	F
Special versions				F	F
Only for selection of more than one hardware option (Additional hardware option = "A")				6SL4113-0 ■ ... - . A . 0	-Z...+...+...
OM-DQ Option Module DRIVE-CLiQ				T01	T01
OM-ILoT Option Module ILoT ¹⁾				T04	T04
OM-SMT Option Module Safe Motor Temperature				T05	T05

More information

Further technical specifications and documentation are available on the internet at:
www.siemens.com/sinamics-g220/documentation

and concerning ordering and configuration via the Siemens Product Configurator in SiePortal:
www.siemens.com/sinamics-g220/configuration

¹⁾ Available soon.

Clicking to SiePortal

6SL3255-0AA00-5AA0



SINAMICS G220 built-in and wall-mounted units

IP20/UL Open Type · 380 ... 500 V 3 AC · 1.1 kW to 55 kW (1.5 hp to 75 hp)

Line-side components					DC link components	Load-side power components	
Line reactors	Recommended line-side overcurrent protection devices				Braking resistors	Output reactors	dv/dt filters plus VPL
	More information at: www.siemens.com/sinamics-g220/ocpd Fuses IEC-compliant Fuses UL/cUL-compliant Rated voltage 600 V AC						
Article No.	Current A	Article No.	Fuse type Class/Article No.	Current A	Article No.	Article No.	Article No.
A DC line reactor is integrated – therefore no line reactor is required.	6	3NA3801	J	6	6SL3201-0BE14-3AA0	–	available soon
	10	3NA3803	J	8		–	available soon
	10	3NA3803	J	10	6SL3201-0BE21-0AA0	–	available soon
	16	3NA3805	J	12		–	available soon
	16	3NA3805	J	15		–	available soon
	20	3NA3807	J	20	6SL3201-0BE21-8AA0	–	available soon
	32	3NA3812	J	30		–	available soon
	40	3NA3817	J	40	6SL3201-0BE23-8AA0	–	available soon
	50	3NA3820	J	50		–	available soon
	63	3NA3822	J	60	JJY:023422620001	–	available soon
	80	3NA3824	J	70		–	available soon
	100	3NA3830	J	90	JJY:023424020001	–	available soon
	100	3NA3830	J	110		–	available soon
	120	3NA3832	J	125	JJY:023434020001	–	available soon
160	3NA3836	J	150		–	available soon	

2

SINAMICS G220 built-in and wall-mounted units

Clicking to SiePortal

6SL3255-0AA00-5AA0



IP55/UL Type 12 · 200 ... 240 V 3 AC · 1.1 kW to 30 kW (1.5 hp to 40 hp)

Selection and ordering data

SINAMICS G220 built-in and wall-mounted units → Configuration with power components (see right page)

Rated power				Rated output current				Rated input current		Frame size	SINAMICS G220 without integrated line filter
Low overload (LO)		High overload (HO)		Low overload (LO)		High overload (HO)		Low overload (LO)			
Acc. to IEC	Acc. to NEC	Acc. to IEC	Acc. to NEC	Acc. to IEC	Acc. to NEC	Acc. to IEC	Acc. to NEC	Acc. to IEC	Acc. to NEC		
230 V	240 V	230 V	240 V	230 V	240 V	230 V	240 V	230 V	240 V		
kW	hp	kW	hp	A	A	A	A	A	A	Article No.	

200 ... 240 V 3 AC · Rated pulse frequency 4 kHz · Input frequency 50/60 Hz (47 ... 63 Hz)

1.1	1.5	0.75	1	6.5	6	4.7	4.2	5.4	5.1	FSB	6SL4112-0 ■ 08 - 0 ■ F 0
1.5	2	1.1	1.5	8.5	6.8	6.5	6	7.1	6.4	FSB	6SL4112-0 ■ 10 - 0 ■ F 0
2.2	3	1.5	2	11	9.6	8.5	6.8	10.1	9.3	FSB	6SL4112-0 ■ 11 - 0 ■ F 0
3	4	2.2	3	14.5	12.4	11	9.6	13.1	11.9	FSB	6SL4112-0 ■ 12 - 0 ■ F 0
4	5	3	4	19	15.2	14.5	12.4	17.7	14.7	FSB	6SL4112-0 ■ 13 - 0 ■ F 0
5.5	7.5	4	5	27	22	19	15.2	21.7	20.1	FSC	6SL4112-0 ■ 15 - 0 ■ F 0
7.5	10	5.5	7.5	34	28	27	22	29.5	26.6	FSC	6SL4112-0 ■ 16 - 0 ■ F 0
11	15	7.5	10	46	42	40	28	41.8	39.5	FSD2	6SL4112-0 ■ 17 - 0 ■ F 0
15	20	11	15	63	54	46	42	53.9	49.7	FSD2	6SL4112-0 ■ 18 - 0 ■ F 0
18.5	25	15	20	75	68	63	54	66.5	62.5	FSD2	6SL4112-0 ■ 20 - 0 ■ F 0
22	30	18.5	25	90	80	75	68	76.0	72.1	FSE	6SL4112-0 ■ 21 - 0 ■ F 0
30	40	22	30	112	104	90	80	103.2	96.1	FSE	6SL4112-0 ■ 23 - 0 ■ F 0

Article No. supplements

Degree of protection	Cooling	Coating acc. to IEC 60721-3-3: 2002	Housing							
IP55/UL Type 12	Internal	Class 3C2	Standard	J						
		Class 3C3 ¹⁾	Maintenance switch ¹⁾	L						
			Standard	K						
			Maintenance switch ¹⁾	M						
Hardware configurations										
Standard										
Gland plate for connecting in IP55 degree of protection according to IEC										
Gland plate for connecting in UL Type 12 degree of protection										
Line filter										
Without integrated line filter										
Additional hardware option										
Without hardware option or with more than one hardware option (see Special versions)										
OM-DQ Option Module DRIVE-CLiQ										
OM-IIoT Option Module IIoT ¹⁾										
OM-SMT Option Module Safe Motor Temperature										
Communication										
PROFINET, Modbus TCP and EtherNet/IP										
Special versions										
Only for selection of more than one hardware option (Additional hardware option = "A")										
6SL4112-0 ■ . . . - A . 0 - Z . . . + . . . + . . .										
OM-DQ Option Module DRIVE-CLiQ										
OM-IIoT Option Module IIoT ¹⁾										
OM-SMT Option Module Safe Motor Temperature										
Order codes										
T01										
T04										
T05										

More information

Further technical specifications and documentation are available on the internet at:
www.siemens.com/sinamics-g220/documentation
 and concerning ordering and configuration via the Siemens Product Configurator in SiePortal:
www.siemens.com/sinamics-g220/configuration

¹⁾ Available soon.

Clicking to SiePortal

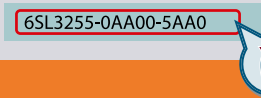

SINAMICS G220 built-in and wall-mounted units

IP55/UL Type 12 · 200 ... 240 V 3 AC · 1.1 kW to 30 kW (1.5 hp to 40 hp)

Line-side components					DC link components	Load-side power components	
Line reactors	Recommended line-side overcurrent protection devices				Braking resistors	Output reactors	dv/dt filters plus VPL
	More information at: www.siemens.com/sinamics-g220/ocpd				Degree of protection IP54		
	Fuses IEC-compliant		Fuses UL/cUL-compliant Rated voltage 600 V AC				
	Current		Fuse type	Current			
Article No.	A	Article No.	Class/Article No.	A	Article No.	Article No.	Article No.
A DC line reactor is integrated – therefore no line reactor is required.	10	3NA3803	J	10	–	–	–
	16	3NA3805	J	12	–	–	–
	16	3NA3805	J	15	–	–	–
	20	3NA3807	J	20	–	–	–
	32	3NA3812	J	30	–	–	–
	40	3NA3817	J	40	–	–	–
	50	3NA3820	J	50	–	–	–
	80	3NA3824	J	70	–	–	–
	100	3NA3830	J	90	–	–	–
	100	3NA3830	J	110	–	–	–
	125	3NA3832	J	125	–	–	–
	160	3NA3836	J	150	–	–	–



SINAMICS G220 built-in and wall-mounted units

Clicking to SiePortal

6SL3255-0AA00-5AA0



IP55/UL Type 12 · 380 ... 500 V 3 AC · 1.1 kW to 55 kW (1.5 hp to 75 hp)

Selection and ordering data

SINAMICS G220 built-in and wall-mounted units → Configuration with power components (see right page)

Rated power		Rated output current				Rated input current		Frame size	SINAMICS G220 without integrated line filter	SINAMICS G220 with integrated line filter	
Low overload (LO)		High overload (HO)		Low overload (LO)		High overload (HO)		Low overload (LO)		High overload (HO)	
Acc. to IEC	Acc. to NEC	Acc. to IEC	Acc. to NEC	Acc. to IEC	Acc. to NEC	Acc. to IEC	Acc. to NEC	Acc. to IEC	Acc. to NEC	Acc. to IEC	Acc. to NEC
400 V	480 V	400 V	480 V	400 V	480 V	400 V	480 V	400 V	480 V	400 V	480 V
kW	hp	kW	hp	A	A	A	A	A	A	Article No.	Article No.

380 ... 500 V 3 AC · Rated pulse frequency 4 kHz · Input frequency 50/60 Hz (47 ... 63 Hz)

1.1	1.5	0.75	1	3.9	3	2.9	2.1	3.3	3.0	FSB	6SL4113-0 ■ ■ 08 - 0 ■ F 0	6SL4113-0 ■ ■ 08 - 2 ■ F 0
1.5	2	1.1	1.5	4.7	3.4	3.9	3	4.1	3.7	FSB	6SL4113-0 ■ ■ 10 - 0 ■ F 0	6SL4113-0 ■ ■ 10 - 2 ■ F 0
2.2	3	1.5	2	6.5	4.8	4.7	3.4	5.6	4.9	FSB	6SL4113-0 ■ ■ 11 - 0 ■ F 0	6SL4113-0 ■ ■ 11 - 2 ■ F 0
3	4	2.2	3	8.5	6.2	6.5	4.8	7.3	6.1	FSB	6SL4113-0 ■ ■ 12 - 0 ■ F 0	6SL4113-0 ■ ■ 12 - 2 ■ F 0
4	5	3	4	11	7.6	8.5	6.2	9.6	7.3	FSB	6SL4113-0 ■ ■ 13 - 0 ■ F 0	6SL4113-0 ■ ■ 13 - 2 ■ F 0
5.5	7.5	4	5	14.5	11	11	7.6	12.9	11.0	FSB	6SL4113-0 ■ ■ 15 - 0 ■ F 0	6SL4113-0 ■ ■ 15 - 2 ■ F 0
7.5	10	5.5	7.5	19	14	14.5	11	17.3	14.0	FSB	6SL4113-0 ■ ■ 16 - 0 ■ F 0	6SL4113-0 ■ ■ 16 - 2 ■ F 0
11	15	7.5	10	27	21	19	14	23.3	19.6	FSC	6SL4113-0 ■ ■ 17 - 0 ■ F 0	6SL4113-0 ■ ■ 17 - 2 ■ F 0
15	20	11.0	15	34	27	27	21	31.3	25.4	FSC	6SL4113-0 ■ ■ 18 - 0 ■ F 0	6SL4113-0 ■ ■ 18 - 2 ■ F 0
18.5	25	15.0	20	40	34	34	27	37.8	31.6	FSD1	6SL4113-0 ■ ■ 20 - 0 ■ F 0	6SL4113-0 ■ ■ 20 - 2 ■ F 0
22	30	18.5	25	46	40	40	34	44.9	37.5	FSD1	6SL4113-0 ■ ■ 21 - 0 ■ F 0	6SL4113-0 ■ ■ 21 - 2 ■ F 0
30	40	22.0	30	63	52	46	40	59.9	49.8	FSD2	6SL4113-0 ■ ■ 23 - 0 ■ F 0	6SL4113-0 ■ ■ 23 - 2 ■ F 0
37	50	30	40	75	65	63	52	72.6	59.9	FSD2	6SL4113-0 ■ ■ 24 - 0 ■ F 0	6SL4113-0 ■ ■ 24 - 2 ■ F 0
45	60	37	50	90	77	75	65	86.7	71.3	FSE	6SL4113-0 ■ ■ 26 - 0 ■ F 0	6SL4113-0 ■ ■ 26 - 2 ■ F 0
55	75	45	60	112	96	90	77	105.9	88.3	FSE	6SL4113-0 ■ ■ 27 - 0 ■ F 0	6SL4113-0 ■ ■ 27 - 2 ■ F 0

Article No. supplements

Degree of protection	Cooling	Coating acc. to IEC 60721-3-3: 2002	Housing	J	L	K	M
IP55/UL Type 12	Internal	Class 3C2	Standard				
		Class 3C3 ¹⁾	Maintenance switch ¹⁾				
			Standard				
			Maintenance switch ¹⁾				

Hardware configurations

Standard	A
Gland plate for connecting in IP55 degree of protection according to IEC	P
Gland plate for connecting in UL Type 12 degree of protection	Q

Line filter

Without integrated line filter	0
With integrated line filter Category C2	2

Additional hardware option

Without hardware option or with more than one hardware option (see Special versions)	A
OM-DQ Option Module DRIVE-CLiQ	B
OM-ILoT Option Module ILoT ¹⁾	E
OM-SMT Option Module Safe Motor Temperature	F

Communication

PROFINET, Modbus TCP and EtherNet/IP	F
--------------------------------------	---

Special versions

Only for selection of more than one hardware option (Additional hardware option = "A")	6SL4113-0 ■ ... - A 0	Order codes	-Z ... + ...
OM-DQ Option Module DRIVE-CLiQ		T01	T01
OM-ILoT Option Module ILoT ¹⁾		T04	T04
OM-SMT Option Module Safe Motor Temperature		T05	T05

More information

Further technical specifications and documentation are available on the internet at:
www.siemens.com/sinamics-g220/documentation

and concerning ordering and configuration via the Siemens Product Configurator in SiePortal:
www.siemens.com/sinamics-g220/configuration

¹⁾ Available soon.

Clicking to SiePortal

GSL3255-0AA00-5AA0



SINAMICS G220 built-in and wall-mounted units

IP55/UL Type 12 · 380 ... 500 V 3 AC · 1.1 kW to 55 kW (1.5 hp to 75 hp)

Line-side components					DC link components	Load-side power components	
Line reactors	Recommended line-side overcurrent protection devices				Braking resistors	Output reactors	dv/dt filters plus VPL
	More information at: www.siemens.com/sinamics-g220/ocpd				Degree of protection IP54		
	Fuses IEC-compliant	Fuses UL/cUL-compliant Rated voltage 600 V AC					
Article No.	Current A	Article No.	Fuse type Class/Article No.	Current A	Article No.	Article No.	Article No.
A DC line reactor is integrated – therefore no line reactor is required.	6	3NA3801	J	6	–	–	–
	10	3NA3803	J	8	–	–	–
	10	3NA3803	J	10	–	–	–
	16	3NA3805	J	12	–	–	–
	16	3NA3805	J	15	–	–	–
	20	3NA3807	J	20	–	–	–
	32	3NA3812	J	30	–	–	–
	40	3NA3817	J	40	–	–	–
	50	3NA3820	J	50	–	–	–
	63	3NA3822	J	60	–	–	–
	80	3NA3824	J	70	–	–	–
	100	3NA3830	J	90	–	–	–
	100	3NA3830	J	110	–	–	–
	120	3NA3832	J	125	–	–	–
160	3NA3836	J	150	–	–	–	

SINAMICS G220 built-in and wall-mounted units

Clicking to SiePortal

6SL3255-0AA00-5AA0



Clean Power/IP20/UL Open Type · 380 ... 500 V 3 AC · 7.5 kW to 55 kW (10 hp to 75 hp)

Selection and ordering data

SINAMICS G220 built-in and wall-mounted units → Configuration with power components (see right page)

Rated power		Rated output current				Rated input current		Frame size	SINAMICS G220 Clean Power with integrated line filter NEW
Low overload (LO)		High overload (HO)		Low overload (LO)		High overload (HO)		Low overload (LO)	Article No.
Acc. to IEC	Acc. to NEC	Acc. to IEC	Acc. to NEC	Acc. to IEC	Acc. to NEC	Acc. to IEC	Acc. to NEC	Acc. to IEC	
400 V	480 V	400 V	480 V	400 V	480 V	400 V	480 V	400 V	
kW	hp	kW	hp	A	A	A	A	A	

380 ... 500 V 3 AC · Rated pulse frequency 4 kHz · Input frequency 50/60 Hz (47 ... 63 Hz)

7.5	10	5.5	7.5	19	14	14.5	11	15.2	12.3	FSD1	6SL4113-2 ■ A 16 - 2 ■ F 0
11	15	7.5	10	27	21	19	14	20.6	17.5	FSD1	6SL4113-2 ■ A 17 - 2 ■ F 0
15	20	11	15	34	27	27	21	28.0	23.2	FSD1	6SL4113-2 ■ A 18 - 2 ■ F 0
18.5	25	15	20	40	34	34	27	33.5	28.5	FSD1	6SL4113-2 ■ A 20 - 2 ■ F 0
22	30	18.5	25	46	40	40	34	39.9	34.2	FSD1	6SL4113-2 ■ A 21 - 2 ■ F 0
30	40	22	30	63	52	46	40	52.9	44.4	FSD2	6SL4113-2 ■ A 23 - 2 ■ F 0
37	50	30	40	75	65	63	52	65.3	55.7	FSD2	6SL4113-2 ■ A 24 - 2 ■ F 0
45	60	37	50	90	77	75	65	77.5	65.5	FSE	6SL4113-2 ■ A 26 - 2 ■ F 0
55	75	45	60	112	96	90	77	95.1	81.9	FSE	6SL4113-2 ■ A 27 - 2 ■ F 0

Article No. supplements

Degree of protection	Cooling	Coating acc. to IEC 60721-3-3: 2002	Housing		
IP20/UL Open Type	Internal	Class 3C2 Class 3C3	Standard	C D	
Hardware configuration				A	
Standard					
Line filter				2	
With integrated line filter Category C2					
Additional hardware option				A B E F	
Without hardware option or with more than one hardware option (see Special versions)					
OM-DQ Option Module DRIVE-CLiQ					
OM-ILoT Option Module ILoT ¹⁾					
OM-SMT Option Module Safe Motor Temperature					
Communication				F	
PROFINET, Modbus TCP and EtherNet/IP					
Special versions					Order codes
Only for selection of more than one hardware option (Additional hardware option = "A")				6SL4113-2 ■ ... - . A . 0	-Z...+...+...
OM-DQ Option Module DRIVE-CLiQ					T01
OM-ILoT Option Module ILoT ¹⁾					T04
OM-SMT Option Module Safe Motor Temperature					T05

More information

Further technical specifications and documentation are available on the internet at:

www.siemens.com/sinamics-g220/documentation

and concerning ordering and configuration via the Siemens Product Configurator in SiePortal:

www.siemens.com/sinamics-g220/configuration

¹⁾ Available soon.

Clicking to SiePortal

6SL3255-0AA00-5AA0



SINAMICS G220 built-in and wall-mounted units

Clean Power/IP20/UL Open Type · 380 ... 500 V 3 AC · 7.5 kW to 55 kW (10 hp to 75 hp)

Line-side components					DC link components	Load-side power components	
Line reactors	Recommended line-side overcurrent protection devices				Braking resistors	Output reactors	dv/dt filters plus VPL
	More information at: www.siemens.com/sinamics-g220/ocpd Fuses IEC-compliant Fuses UL/cUL-compliant Rated voltage 600 V AC						
Article No.	Current A	Article No.	Fuse type Class/Article No.	Current A	Article No.	Article No.	Article No.
A DC line reactor is integrated – therefore no line reactor is required.	32	3NA3812	J	30	6SL3201-0BE21-8AA0	–	–
	40	3NA3817	J	40	6SL3201-0BE23-8AA0	–	–
	50	3NA3820	J	50		–	–
	63	3NA3822	J	60	JJY:023422620001	–	–
	80	3NA3824	J	70		–	–
	100	3NA3830	J	90	JJY:023424020001	–	–
	100	3NA3830	J	110		–	–
	125	3NA3832	J	125	JJY:023434020001	–	–
	160	3NA3836	J	150		–	–

2

SINAMICS G220 built-in and wall-mounted units

Supplementary system components

Selection and ordering data

Supplementary system components for SINAMICS G220 built-in and wall-mounted units

Description	Article No.
Option Modules ¹⁾ for SINAMICS G220 <ul style="list-style-type: none"> • OM-DQ Option Module DRIVE-CLiQ • OM-IloT Option Module IloT ³⁾ • OM-SMT Option Module Safe Motor Temperature 	6SL4950-0AL00-0BA0 6SL4950-0AL00-0EA0 6SL4950-0AL00-0FA0
Additional components for SINAMICS G220 <ul style="list-style-type: none"> • SINAMICS Smart Adapter Wi-Fi solution for the next generation of SINAMICS converters • SMC20 Sensor Module Cabinet-Mounted Without DRIVE-CLiQ cable • SMC30 Sensor Module Cabinet-Mounted Without DRIVE-CLiQ cable 	6SL4950-0AJ00-0AA0 6SL3055-0AA00-5BA3 6SL3055-0AA00-5CA2
Accessories for re-ordering of SMC20 and SMC30 <ul style="list-style-type: none"> • Dust protection blanking plugs (50 units) For DRIVE-CLiQ port 	6SL3066-4CA00-0AA0
Smart Drive Interfaces ³⁾ for SINAMICS G220 <ul style="list-style-type: none"> • SINAMICS SDI Pro 5.5" ³⁾ • SINAMICS SDI Pro 5.5" handheld kit for use with the SINAMICS SDI Pro 5.5" • SINAMICS SDI Pro 5.5" door mounting kit for mounting a SINAMICS SDI Pro 5.5" in control cabinet doors • SINAMICS IP55 panel mounting frame 	6SL4950-0AH35-2AA0 6SL4950-0AH65-0AA0 6SL4950-0AH55-0AA0 6SL4950-0AH75-0AA0

SINAMICS Drive Software Options for SINAMICS G220 built-in and wall-mounted units

Description	Article No.
Delivery with SD card, 8 GB The parameter assignment, firmware and licenses for a converter can be stored on the memory card. <ul style="list-style-type: none"> • SD card without firmware (empty) • With SINAMICS Motor Control Extended (license) • With SINAMICS Safety Integrated Extended (license) • With SINAMICS Motor Control Extended (license) and SINAMICS Safety Integrated Extended (license) 	6SL5970-0AA00-0AA0 6SL5970-0AA00-0AA0-Z H01 6SL5970-0AA00-0AA0-Z F01 6SL5970-0AA00-0AA0-Z H01+F01
<ul style="list-style-type: none"> • SD card with firmware V6.2 • With firmware V6.2 and SINAMICS Motor Control Extended (license) • With firmware V6.2 and SINAMICS Safety Integrated Extended (license) • With firmware V6.2 and SINAMICS Motor Control Extended (license) and SINAMICS Safety Integrated Extended (license) 	6SL4170-1GC00-0AA0 6SL4170-1GC00-0AA0-Z H01 6SL4170-1GC00-0AA0-Z F01 6SL4170-1GC00-0AA0-Z H01+F01
Delivery in electronic form, eCoL (without SD card) ²⁾ <ul style="list-style-type: none"> • SINAMICS Motor Control Extended (license) • SINAMICS Safety Integrated Extended (license) 	6SL5977-0AA00-1DA0 6SL5977-0AA00-2HA0

For an overview and more information on all available firmware versions, see <https://support.industry.siemens.com/cs/document/109807094>

¹⁾ Option Modules can also be ordered directly as a part of the converter as an additional hardware option or a special version.

²⁾ The memory card is not included in the scope of delivery. The Safety license and the SINAMICS Motor Control Extended license can also be ordered together with a memory card (see above). With the Certificate of License (CoL) in electronic form, the license is supplied as a PDF file. Notification of this with a download link is received by email.

Safety Integrated

The integrated safety functions provide highly effective, application-oriented protection for personnel and machinery (terms as defined in IEC 61800-5-2).

The following Safety Integrated Basic Functions are included as standard:

- Safe Torque Off (STO)
- Safe Stop 1 time-controlled (SS1-t)
- Safe Motor Temperature (SMT) in combination with the optional OM-SMT Option Module Safe Motor Temperature

The following Safety Integrated Extended Functions are available as options:

- Safe Stop 1 (SS1) with SBR/SAM
- Safely-Limited Speed (SLS)
- Safe Direction (SDI)
- Safe Speed Monitor (SSM)

The Safety Integrated Functions are implemented electronically and therefore require no additional installation effort or space in the control cabinet. Furthermore, the costs are considerably lower than for externally implemented monitoring functions.

The Safety Integrated Functions can be easily commissioned using the web server of the converter or SINAMICS Startdrive commissioning tool in TIA Portal.

Environmental Product Declaration (EPD)

Environmental Product Declarations (EPD) are available as PDFs for this product.

The EPD PDF provides brief and concise information about the ecological properties of a product.

You can find more information on the internet at: <https://support.industry.siemens.com/cs/ww/en/ps/28308/cert?ci=5690>

More information

Further technical specifications and documentation, such as the operating instructions, are available on the internet at: www.siemens.com/sinamics-g220/documentation

Detailed information on the SINAMICS G220 built-in and wall-mounted units, including the latest technical documentation (brochures, tutorials, dimensional drawings, certificates, manuals and operating instructions), is available on the internet at:

www.siemens.com/sinamics-g220

and also via the Siemens Product Configurator in SiePortal: www.siemens.com/sinamics-g220/configuration

³⁾ Available soon.

Overview



The SINAMICS G220 converter features Safety Integrated Functions as standard.

Safety Integrated overview

The Safety Integrated Functions are implemented electronically and therefore offer short response times and easy handling in comparison to solutions with externally implemented monitoring functions.

The integrated safety functions comply with the requirements of SIL 3 according to IEC 61508 and IEC 61062 and PL e/category 4 according to ISO 13849-1.

No additional license is required for the Basic Functions STO, SS1-t and SMT. One Safety Extended Runtime license per device is required for the Extended Functions SS1-r, SS1-a, SLS, SSM and SDI.

Use of the Basic Functions does not require a motor encoder, but use of the Extended Functions does require a Safety-capable encoder connected via DRIVE-CLiQ or SMC20 Sensor Module Cabinet-Mounted.

Controlling the Safety Integrated Functions

The Safety Integrated Functions are completely integrated into the drive system. They can be activated via fail-safe digital inputs or via PROFINET with PROFIsafe.

The SINAMICS G220 converter has up to three fail-safe digital inputs.

The STO function in the converter is released ex works, and is assigned to the fail-safe digital input F-DI 0. When wiring an emergency stop operating device, the STO function can therefore be used right away with no additional configuration. The F-DI 0 is delivered with a bridge, meaning that the drive can be operated even without wiring an emergency stop operating device.

To comply with the requirements of ISO 13849-1 and IEC 61508 for timely error detection, the fail-safe inputs and switch-off signal paths of the SINAMICS G220 are tested cyclically and automatically during operation. A test stop and consequent shutdown of the drive is therefore not necessary for error detection.

OM-SMT Option Module Safe Motor Temperature



OM-SMT Option Module Safe Motor Temperature

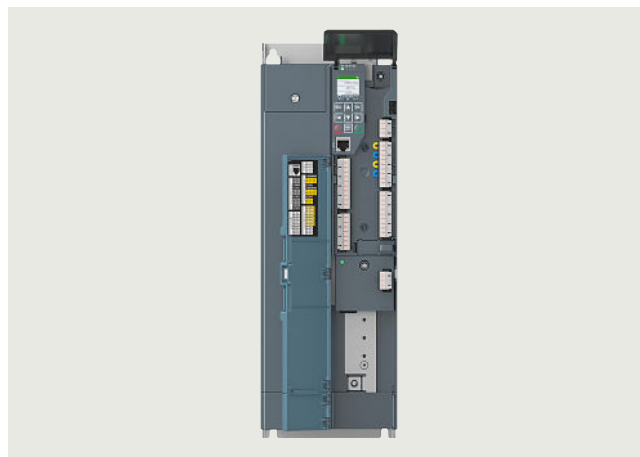

Integrated safety solution: SINAMICS G220 with inserted OM-SMT Option Module Safe Motor Temperature

The OM-SMT Option Module (Safe Motor Temperature)

- is suitable for monitoring the temperature of a motor in an explosive atmosphere (ATEX applications).
- is required for the SMT (Safe Motor Temperature) safety function.
- monitors the temperature of motors with two connected PTC temperature sensors for a warning threshold and a shutdown threshold.
- also detects short-circuits and wire breaks in the sensor circuit.
- detects when the limit temperature is exceeded. Once the shutdown threshold is reached, the converter automatically triggers the STO stop function, which prevents the motor from receiving any more energy from the converter; and the temperature can no longer rise.
- is classified for EX II (2) GD. Shutdown is certified for ATEX to SIL 2 in accordance with IEC 61508 and IEC 61062 and PL d, category 3 in accordance with ISO 13849-1.
- is intended for operation in the option slot of the converter. Operation is possible in converters with degree of protection IP20 / UL Open Type and IP55 / UL Type 12.

SINAMICS G220 built-in and wall-mounted units

Safety Integrated for SINAMICS G220

Function

Function	Control	Underlying function	Reaction to limit overshoot	Encoder required	License required
Basic functions (no additional license is required)					
STO	<ul style="list-style-type: none"> F-DI PROFIsafe 	–	–	No	No
SS1 time-controlled	<ul style="list-style-type: none"> F-DI PROFIsafe 	Following expiry of the parameterized delay time or if the speed falls below the minimum speed limit STO	–	No	No
SMT	–	When STO limit temperature exceeded	STO	No	No
Extended functions (an additional license is required)					
SS1 with SBR/SAM	<ul style="list-style-type: none"> F-DI PROFIsafe 	Safe Acceleration Monitor (SAM) or Safe Brake Ramp (SBR) during braking. Following expiry of the parameterized delay time or if the speed falls below the minimum speed limit STO	STO	Yes	Yes
SLS	<ul style="list-style-type: none"> F-DI PROFIsafe 	–	STO, SS1 (can be parameterized)	Yes	Yes
SDI	<ul style="list-style-type: none"> F-DI PROFIsafe 	–	STO, SS1 (can be parameterized)	Yes	Yes
SSM	<ul style="list-style-type: none"> F-DI PROFIsafe 	–	Signals that the speed has fallen below a specified value	Yes	Yes

2

SINAMICS G220 built-in and wall-mounted units

Supplementary system components

Option Modules > OM-DQ Option Module DRIVE-CLiQ

Overview



SINAMICS G220 OM-DQ Option Module DRIVE-CLiQ

The OM-DQ Option Module DRIVE-CLiQ connects the converter to DRIVE-CLiQ modules.

The OM-DQ Option Module DRIVE-CLiQ is intended for operation in the option slot of the converter. Operation is possible in converters with degree of protection IP20 / UL Open Type and IP55 / UL Type 12. The OM-DQ Option Module DRIVE-CLiQ connects the converter to other Option Modules or DRIVE-CLiQ modules that are mounted outside the converter.

Selection and ordering data

Description	Article No.
OM-DQ Option Module DRIVE-CLiQ	
• For ordering as a supplementary system component or a spare part	6SL4950-0AL00-0BA0
• For ordering as a part of the converter with an order code	6SL4.....-.....-Z T01

Technical specifications

	OM-DQ Option Module DRIVE-CLiQ 6SL4950-0AL00-0BA0
Max. current consumption (at 24 V DC)	0.08 A
Weight	0.075 kg
Operating temperature	-20 ... 60 °C
Transfer rate	100 Mbit/s

SINAMICS G220 built-in and wall-mounted units

Supplementary system components

Option Modules > OM-IIoT Option Module IIoT

Overview



SINAMICS G220 OM-IIoT Option Module IIoT

The OM-IIoT Option Module IIoT connects the converter to the Industrial Internet of Things (IIoT).

The OM-IIoT Option Module IIoT is intended for operation in the option slot of the converter. Operation is possible in converters with degree of protection IP20 / UL Open Type and IP55 / UL Type 12. The OM-IIoT Option Module IIoT can be operated outside the option slot via the OM-DQ Option Module DRIVE-CLiQ.

Selection and ordering data

Description	Article No.
OM-IIoT Option Module IIoT ¹⁾	6SL4950-0AL00-0EA0
• For ordering as a supplementary system component or a spare part	6SL4...-...-...-Z
• For ordering as a part of the converter with an order code	T04

Technical specifications

	OM-IIoT Option Module IIoT 6SL4950-0AL00-0EA0
Max. current consumption (at 24 V DC)	0.08 A
Weight	0.075 kg
Operating temperature	-20 ... 60 °C

¹⁾ Available soon.

SINAMICS G220 built-in and wall-mounted units

Supplementary system components

Option Modules > OM-SMT Option Module Safe Motor Temperature

Overview



SINAMICS G220 OM-SMT Option Module Safe Motor Temperature

The OM-SMT Option Module Safe Motor Temperature is suitable for monitoring the temperature of a motor in a hazardous atmosphere.

The OM-SMT Option Module Safe Motor Temperature monitors the temperature of motors with two connected PTC temperature sensors. It also detects short-circuits and wire breaks in the sensor circuit.

The OM-SMT Option Module Safe Motor Temperature is intended for operation in the option slot of the converter. Operation is possible in converters with degree of protection IP20 / UL Open Type and IP55 / UL Type 12. The OM-SMT Option Module Safe Motor Temperature can be operated outside the option slot via the OM-DQ Option Module DRIVE-CLiQ.

Selection and ordering data

Description	Article No.
OM-SMT Option Module Safe Motor Temperature <ul style="list-style-type: none"> For ordering as a supplementary system component or a spare part For ordering as a part of the converter with an order code 	6SL4950-0AL00-0FA0 6SL4.....-.....-Z T05

Technical specifications

	OM-SMT Option Module Safe Motor Temperature 6SL4950-0AL00-0FA0
Max. current consumption (at 24 V DC)	0.08 A
Weight	0.075 kg

SINAMICS G220 built-in and wall-mounted units

Supplementary system components

Smart Drive Interfaces

Overview

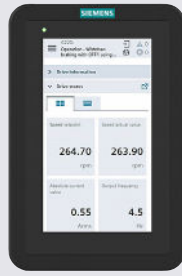
Operator panel	SINAMICS SDI Standard	SINAMICS SDI Pro 5.5"
Description	 <p>With its high-contrast color display (1.4"), menu navigation and the extensive functionality provided by the integrated web server of the connected converter, it is easy to implement commissioning, diagnostics, operator control and monitoring, and service scenarios of the standard drives, for example.</p>	 <p>Thanks to the high-contrast color touch display (5.5"), menu navigation and the extensive functionality provided by the integrated web server of the connected converter, it is easy to implement commissioning, diagnostics, operator control and monitoring, and service scenarios of the standard drives, for example.</p>
Possible applications	<ul style="list-style-type: none"> • Integrated into the SINAMICS G220 converter 	<ul style="list-style-type: none"> • Mountable on the SINAMICS G220¹⁾ IP55 converter with adapter • Can be mounted in a control cabinet door using a door mounting kit (achievable degree of protection is IP55/UL type 12 enclosure) • The SINAMICS SDI Pro 5.5" can also be used as a handheld device when using the handheld kit. • Wired connection to the converter via the service interface (X127) or PROFIBUS interface (X150) • Direct power supply via the service interface of the converter (X127)
Quick commissioning without expert knowledge		<ul style="list-style-type: none"> • Easy commissioning of standard applications via quick/advanced commissioning, no knowledge of the parameter structure necessary • Series commissioning with clone function (backup/restore). Backup files are stored directly on the SINAMICS SDI Pro 5.5" • User-defined parameter list with focused, custom parameter selection • Simple on-site commissioning thanks to its use as a handheld
High degree of operator friendliness and intuitive handling	<ul style="list-style-type: none"> • Intuitive navigation with integrated keyboard • Graphical color display (1.4") to show status values such as pressure or flow rate in the form of scalar values • Status display with freely selectable units to specify physical values • User interface has context-sensitive help, making diagnostics of alarms, for example, possible with minimal documentation • Direct manual operation of the drive with easy switchover between the automatic and manual modes • The following languages are supported: English, French, German, Italian, Spanish, Chinese Simplified 	<ul style="list-style-type: none"> • Intuitive navigation thanks to touch operation • Graphic color touch display (5.5") to show status values such as pressure or flow rate in the form of scalar values • Status display with predefined units • User interface has context-sensitive help, making commissioning or diagnostics of alarms, for example, possible with minimal documentation • Direct manual operation of the drive with the control panel • The SINAMICS SDI Pro 5.5" lets the user easily access a large number of converters (installed in a cabinet, for example) either with an automatically or manually created converter list. • The following languages are supported: English, French, German, Italian, Spanish, Chinese Simplified
Minimization of maintenance times	<ul style="list-style-type: none"> • Diagnostics using plain text display, can be used locally on-site without documentation • The support function allows for easy access to information about the converter, for which it provides QR code links. • Using the support function, the display can show a QR code representing the IP address of the service/fieldbus interface currently configured on the converter. By scanning the code (for example, with a smartphone), the user can easily access the integrated web server of the converter. • Simple cloning of the SINAMICS SDI default settings with the converter's backup/restore function. • Updating of the SINAMICS SDI standard function with a drive firmware upgrade. 	<ul style="list-style-type: none"> • Diagnostics using plain text display; can be used locally on-site without documentation • The support function allows for easy access to information about the SINAMICS SDI Pro and the converter, for which it provides QR code links. • Simple cloning of the SDI Pro settings with the backup/restore function of the Panel. • Thanks to the USB C interface on the SINAMICS SDI Pro, the Panel can be upgraded to the latest features. The upgrade only affects the internal functionality of the SINAMICS SDI Pro. The user interface of the converter is not affected. It is provided by the respective converter.

¹⁾ Release for SINAMICS S200 and SINAMICS S210 (New) available soon.

Overview



SINAMICS G220 SDI Standard

The SINAMICS SDI Standard is a highly user-friendly Operator Panel for the SINAMICS G220. The SDI Standard supports newcomers and drive experts alike with essential tasks locally on the device. Thanks to its high-contrast 1.4" color display and membrane keyboard, the device can assist with diagnosing faults in plain text, operation and monitoring, and with maintenance and servicing of the converter on site.

The user interface to the converter is provided by the converter's built-in web server. The technology in the SDI Standard gives it access to select functions of the web server.

This includes:

- Home page with selected display values (values are configurable)

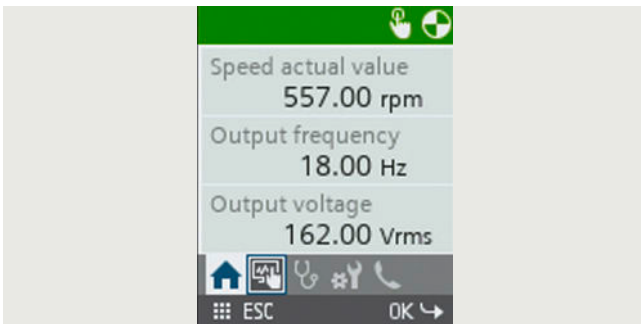

- Operate motor in manual operation

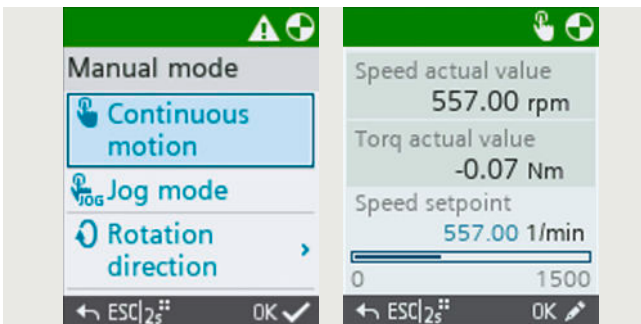

- Diagnose alarms in plain text and view fault cause/remedy messages



- System settings to configure the web server, converter interfaces, date and time and display settings (brightness, backlight timer) as well as the user interface language

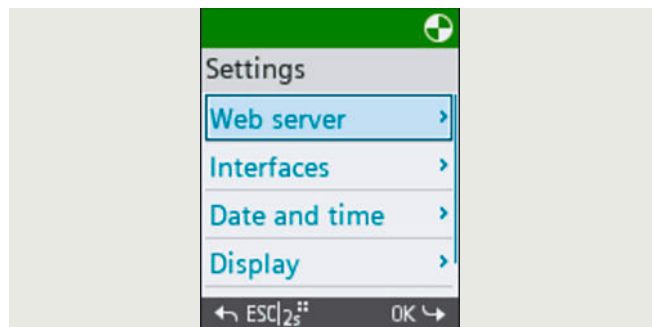

- Support page with scannable information (QR code) for the configured IP address of the service interface and PROFINET interface (X127 / X150) and for the individual components of the SINAMICS G220 drive.

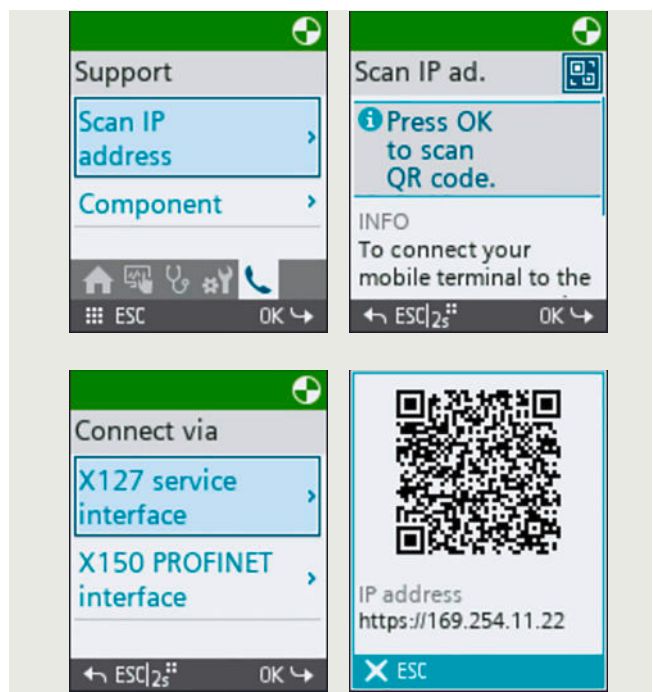

SINAMICS G220 built-in and wall-mounted units

Supplementary system components

Smart Drive Interfaces > SINAMICS SDI Standard

Selection and ordering data

Description	Article No.
SINAMICS SDI Standard integrated in SINAMICS G220 Operating languages: German, English, French, Italian, Spanish, Chinese Simplified	6SL4950-0AH12-2AA0

Technical specifications

	SINAMICS SDI Standard 6SL4950-0AH12-2AA0
Display • Resolution	1.4" color display 128 x 160 pixels
User languages	German, English, French, Italian, Spanish, Chinese Simplified
Converter service interface	X127 service interface (1 RJ45)
Ambient temperature • During storage • During transport • During operation - without power reduction, max.	-25 ... +55 °C (-13 ... +131 °F) -40 ... +70 °C (-40 ... +158 °F) -20 ... +60 °C (-4 ... +140 °F) +40 °C (+104 °F)
Environmental class/harmful chemical substances • Operation	
Air humidity	Relative air humidity < 95 %, non-condensing
Degree of protection	IP20/IP55
Certificate of suitability	UL, cUL, CE, EAC, REACH, RoHS II, Green Passport

2

SINAMICS G220 built-in and wall-mounted units

Supplementary system components

Smart Drive Interfaces > SINAMICS SDI Pro 5.5"

Overview

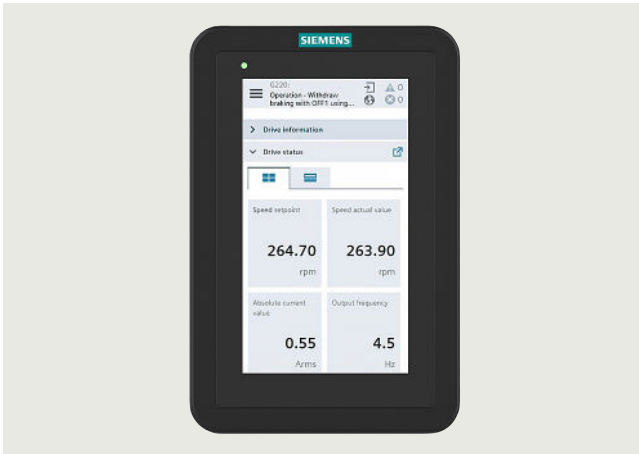

SINAMICS SDI Pro 5.5"

The SINAMICS SDI Pro 5.5" represents a powerful and user-friendly Operator Panel for SINAMICS G220, SINAMICS S200¹⁾ and SINAMICS S210 (New)¹⁾. The SDI Pro supports both newcomers and drive experts. Thanks to its touch interface and high-contrast 5.5" color display, it goes hand-in-glove for commissioning, diagnostics, operator control and monitoring as well as on-site maintenance and servicing of converters.

The user interface to the converter is provided by the converter's built-in web server. The technology of the SDI Pro grants full access to the functionality of the web server.

The supported web server functions pertaining to each converter can be found here:

- SINAMICS G220 ⇒ For more information on web server functions, see [SINAMICS web server for SINAMICS G220](#).
- SINAMICS S200¹⁾ ⇒ For more information on web server functions, see [SINAMICS web server for SINAMICS S200](#).
- SINAMICS S210 (New)¹⁾ ⇒ For more information on web server functions, see [SINAMICS web server for SINAMICS S210 \(New\)](#).

In addition, the SDI Pro offers its own configuration interface with the following settings options:

- SDI Pro main menu

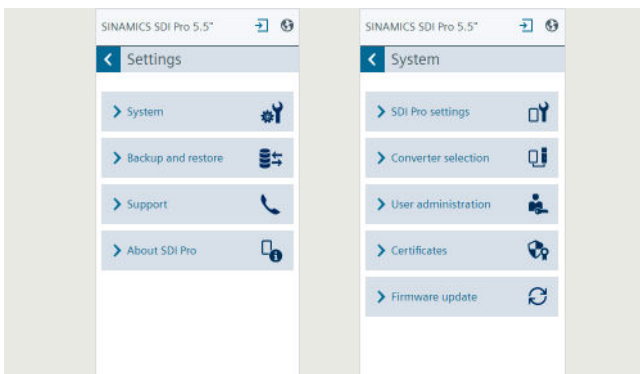

- Set the SDI Pro system settings such as user interface language, real-time clock, interface settings, display settings, change background image of the home screen



- Back up and restore the SDI Pro device settings

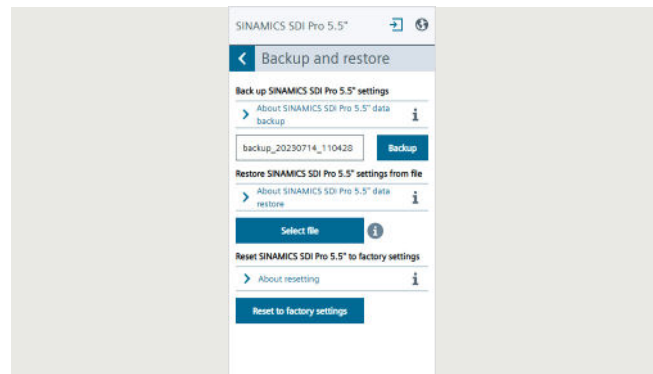

- Access product-specific information (e.g. manuals, downloads, FAQs) and information on SDI Pro (e.g. currently installed firmware version, security notifications)

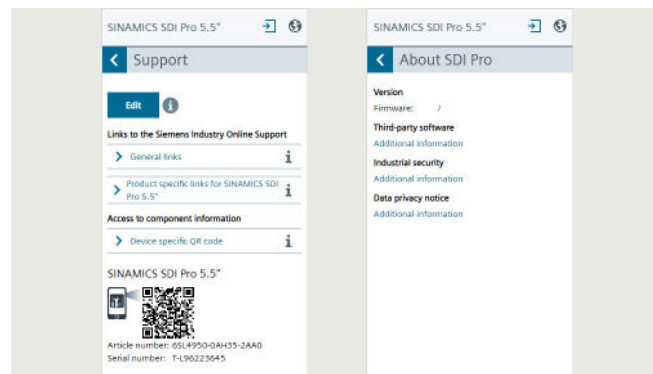

The additional available options in the form of the SINAMICS SDI Pro 5.5" handheld kit and SINAMICS SDI Pro 5.5" door mounting kit extend the operating range of the device. With the SDI Pro 5.5" handheld kit, the device can be equipped with a rubber oversheath for mobile use. The SINAMICS SDI Pro 5.5" door mounting kit enables the SINAMICS SDI Pro to be installed in control cabinet doors.

¹⁾ Release for SINAMICS S200 and SINAMICS S210 (New) available soon.

SINAMICS G220 built-in and wall-mounted units

Supplementary system components

Smart Drive Interfaces > SINAMICS SDI Pro 5.5"

Selection and ordering data

Description	Article No.
SINAMICS SDI Pro 5.5" ^{2) 4) 5)} for use with SINAMICS G220 SINAMICS S200 ¹⁾ SINAMICS S210 (New) ¹⁾ Operating languages: German, English, French, Italian, Spanish, Chinese Simplified	6SL4950-0AH35-2AA0
Accessories	
SINAMICS SDI Pro 5.5" handheld kit ^{2) 5)} for use with the SINAMICS SDI Pro 5.5" Included in the scope of delivery: • Handheld housing • Ethernet connecting cable Length 3 m (9.84 ft), can be used to connect a SINAMICS SDI Pro 5.5" with a converter	6SL4950-0AH65-0AA0
SINAMICS SDI Pro 5.5" door mounting kit ^{2) 5)} for mounting a SINAMICS SDI Pro 5.5" in control cabinet doors with metal thicknesses of 1 ... 3 mm (0.04 ... 0.12 in) Degree of protection IP55 Included in the scope of delivery: • Metal plate for installing the SINAMICS SDI Pro 5.5" • Fixing accessories	6SL4950-0AH55-0AA0
SINAMICS IP55 panel mounting frame ⁵⁾ for SINAMICS G220 Included in the scope of delivery: • SINAMICS IP55 panel mounting frame • Ethernet connecting cable, length approx. 15 cm (5.91 in)	6SL4950-0AH75-0AA0
Bundle SINAMICS SDI Pro 5.5" with SINAMICS IP55 panel mounting frame ⁵⁾ for SINAMICS G220 Included in the scope of delivery: • SINAMICS SDI Pro 5.5" • SINAMICS IP55 panel mounting frame • Ethernet connecting cable, length approx. 15 cm (5.91 in)	6SL4950-0AH45-0AA0
IE TP Cord RJ45/RJ45 ³⁾ Patch cable, available fully assembled • With 4 x 2 cores for 10/100/1000 Mbps Ethernet • Small cable diameter • Cat6 _A (4 x 2) of the ISO/IEC 11801 and EN 50173 international cabling standards 0.3 m 0.5 m 1 m 2 m 3 m 4 m 6 m 10 m 15 m 20 m 25 m 30 m	6XV1870-3QE30 6XV1870-3QE50 6XV1870-3QH10 6XV1870-3QH20 6XV1870-3QH30 6XV1870-3QH40 6XV1870-3QH60 6XV1870-3QN10 6XV1870-3QN15 6XV1870-3QN20 6XV1870-3QN25 6XV1870-3QN30

¹⁾ For information on updates to the SINAMICS SDI Pro 5.5", see www.siemens.com/sinamics-sdi-pro-dl

²⁾ The Ethernet connection cable to connect the SDI Pro to the service interface of the converter (X127) or the PROFINET interface (X150) must be ordered separately.
 To use the operator panel without an additional power supply at the service interface of the converter (X127; point-to-point connection), an 8-wire RJ45 Ethernet cable is required. Pre-assembled cables can be ordered as an accessory.

³⁾ For applications where the space behind the SINAMICS SDI Pro 5.5" is very limited, a cable with angled connectors can be used. Such cables can be purchased from HARTING under the order number 09 48 858 5745 050. For information on HARTING cables visit www.harting.com.

⁴⁾ Release for SINAMICS S200 and SINAMICS S210 (New) available soon.

⁵⁾ Available soon.

Benefits

- User interface
 - Intuitive user interface for the drive provided by the converter itself
 - High-contrast 5.5" color touch display
 - SINAMICS SDI Pro device design open for future function expansions (e.g. device functions, languages)
 - Easily upgradable to latest features via USB C interface
- Commissioning
 - Easy commissioning of the connected converter via the Quick/Advanced Commissioning Wizard. Neither variant requires expert knowledge of converter parameters.
 - Quick commissioning gives the user simple and fast access to all the basic parameters required to commission simple applications.
 - Advanced commissioning provides the parameters required to commission more complex applications, dispensing with the need to switch between different areas within the user interface.
 - Fast series commissioning of frequency converters thanks to cloning function (backup/restore)
 - For quicker access right on the SDI Pro, the names of the backup files you wish to create can be entered or modified with the on-screen keyboard.
 - Context-sensitive help functions provide support for the user during commissioning.
 - Simple local commissioning on-site using the handheld kit
- Operator control and monitoring
 - Simple, individual local drive control (start/stop, setpoint value specification, change in direction of rotation)
 - Actual values from the converter are displayed clearly. You can change the parameters you wish to monitor depending on the requirement.
- Diagnostics
 - Rapid diagnostics thanks to on-site plain text display
 - Integrated plain text help function for local display and resolution of fault messages
- Service and Support function
 - Input/output of a service contact person
 - Easy access to component information via QR code shown on the display
 - Quick access to product information, documentation, FAQs using mobile devices (e.g. smartphones, tablets) by scanning a QR code generated on the SDI Pro
 - Optional scanning and evaluation of the QR code with the Industry Online Support app (<https://support.industry.siemens.com/cs/ww/en/sc/2067>)
 - Simple cloning of specific settings of the SINAMICS SDI Pro such as the language setting, backlight timer, date/time settings, interface settings (IP address), list of available converters, user administration of the SDI Pro. Settings made once can thus be transferred easily to many other SINAMICS SDI Pro 5.5" devices.
 - Firmware upgrade for the SINAMICS SDI Pro 5.5"
 The SDI Pro can be updated and expanded with the integrated USB C port.
 Data can be transferred from a PC to the device for future expansions. Furthermore, the USB interface allows user languages and firmware updates¹⁾ that will become available in future to be downloaded.
- Management of users allowed to have access to the SDI Pro settings (UMAC)
- Management of certificates for encrypted communication to the converter (https)

SINAMICS G220 built-in and wall-mounted units

Supplementary system components

Smart Drive Interfaces > SINAMICS SDI Pro 5.5"

Integration

- Flexible deployment in point-to-point and network configurations
 - The SDI Pro can either be connected to the service interface (X127) or the PROFINET interface (X150) of the converter.
 - SDI Pro can be directly supplied with power via the converter service interface. An external power supply is not required.¹⁾
- If the SDI Pro is operated in a network with n converters ($1 < n \leq 20$), the converters can be accessed in a flexible way via a drive list. As such, a wide range of converters can be operated or diagnosed via an SDI Pro, for instance. The drive list can be conveniently created on the SDI Pro either automatically or manually.

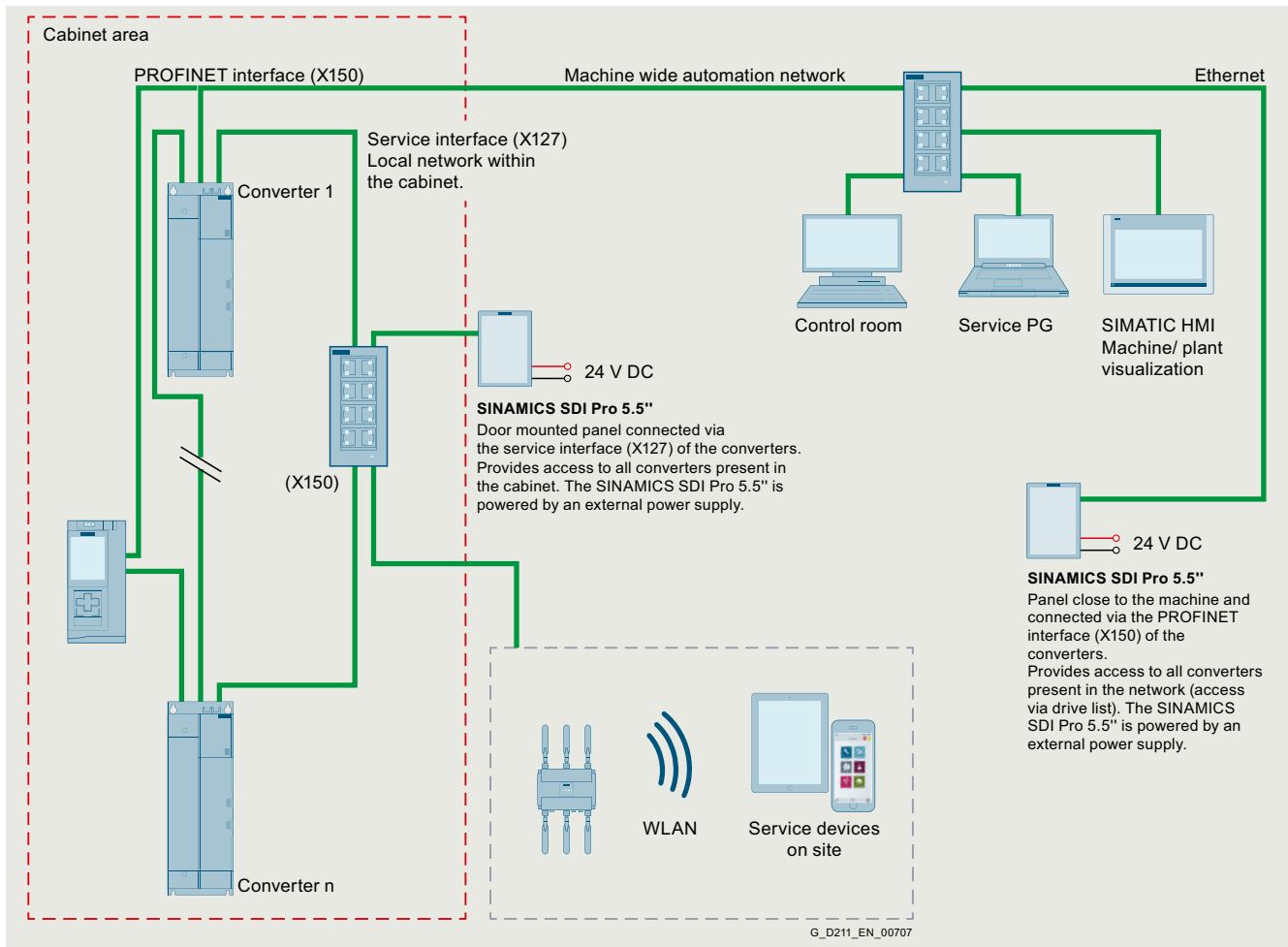

Application example in which multiple converters in a control cabinet can be reached with one SINAMICS SDI Pro

¹⁾ To use the operator panel without an additional power supply at the service interface of the converter (X127; point-to-point connection), an 8-wire RJ45 Ethernet cable is required. Pre-assembled cables can be ordered as an accessory.

SINAMICS G220 built-in and wall-mounted units

Supplementary system components

Smart Drive Interfaces > SINAMICS SDI Pro 5.5"

Technical specifications

SINAMICS SDI Pro 5.5" 6SL4950-0AH35-2AA0	
Display • Resolution	High-contrast color display 320 × 580 pixels
Operator panel	Touch display
User languages	German, English, French, Italian, Spanish, Chinese Simplified
Power supply	20 ... 29 V DC 24 V DC via the RJ45 (8-core) X127 cable connection from the converter ¹⁾ or external power supply via the external power supply terminals on the Operator Panel
Current, max.	300 mA
Ambient temperature • During transport and storage • During operation	-40 ... +70 °C (-40 ... +158 °F) When using the SINAMICS SDI Pro 5.5" handheld kit: -20 ... +55 °C (-4 ... +131 °F) If installed with the SINAMICS SDI Pro 5.5" door mounting kit: -20 ... +55 °C (-4 ... +131 °F)
Air humidity	Relative air humidity < 95 %, non-condensing
Environmental class/harmful chemical substances • Operation	Class 3C3 per IEC 60721-3-3: 2002
Degree of protection	IP20 on the rear side or when in use with the SINAMICS SDI Pro 5.5" handheld kit IP55 on the front side, mounted with the SINAMICS SDI Pro 5.5" door mounting kit
Dimensions (H × W × D)	167 mm × 111 mm × 16.1 mm (6.57 in × 4.37 in × 0.63 in)
Weight, approx.	0.275 kg (0.61 lb)
Certificate of suitability	CE, UKCA, RCM, cULus, EAC, KC-REM-S49-SINAMICS

SINAMICS SDI Pro 5.5" handheld kit 6SL4950-0AH65-2AA0	
Ambient temperature • During transport and storage	-40 ... +70 °C (-40 ... +158 °F)
Air humidity	Relative air humidity < 95 %, non-condensing
Degree of protection	IP20
Weight, approx.	0.265 kg (0.58 lb)

SINAMICS SDI Pro 5.5" door mounting kit 6SL4950-0AH55-0AA0	
Ambient temperature • During transport and storage	-40 ... +70 °C (-40 ... +158 °F)
Air humidity	Relative air humidity < 95 %, non-condensing
Degree of protection	IP20 on the rear side or inside of the cabinet IP55 on the front side, mounted with the SINAMICS SDI Pro 5.5" door mounting kit
Dimensions • Door mounting kit dimensions	Cabinet cutout: 93 mm × 153 mm (3.66 in × 6.02 in), Screws: M4 × 20, 6 pcs., Tightening torque: 0.1 Nm (0.89 lbf-in) / M3 × 6, 2 pcs., Tightening torque: 1.2 Nm (10.6 lbf-in)
Weight, approx.	0.214 kg (0.47 lb)

SINAMICS IP55 Panel mounting frame 6SL4950-0AH75-0AA0	
Ambient temperature • During transport and storage	-40 ... +70 °C (-40 ... +158 °F)
Air humidity	Relative air humidity < 95 %, non-condensing
Degree of protection	IP55, including the SINAMICS SDI Operator Panel
Dimensions • Mounting frame dimensions	180 mm × 150 mm × 35 mm (7.09 in × 5.91 in × 1.38 in), Screws: M4 × 20, 4 pcs., Tightening torque: 1.2 Nm (10.6 lbf-in)
Weight, approx.	0.405 kg (0.89 lb) + 0.275 kg (0.61 lb) if the SINAMICS SDI Pro Operator Panel is inserted in the mounting frame

¹⁾ The Ethernet connection cable to connect the SDI Pro to the service interface of the converter (X127) or the PROFINET interface (X150) must be ordered separately.
To use the operator panel without an additional power supply at the service interface of the converter (X127; point-to-point connection), an 8-wire RJ45 Ethernet cable is required. Pre-assembled cables can be ordered as an accessory.

SINAMICS G220 built-in and wall-mounted units

Supplementary system components

Smart Drive Interfaces > SINAMICS SDI Pro 5.5"

Accessories

SINAMICS SDI Pro 5.5" handheld kit



SINAMICS SDI Pro 5.5" with handheld kit

A handheld kit can be ordered to assist with using the SINAMICS SDI Pro 5.5" while on the go. It contains a rubber housing and a 3 m long Ethernet connecting cable.

SINAMICS IP55 Panel mounting frame

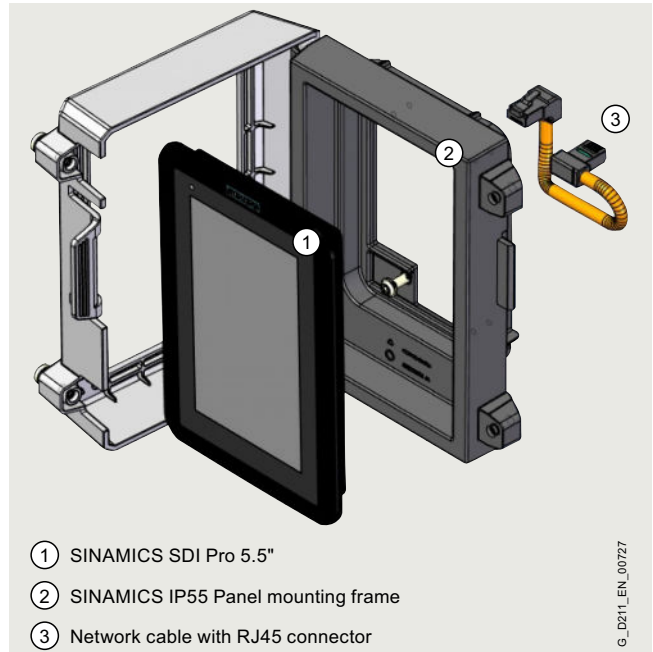

SINAMICS IP55 Panel mounting frame

The SINAMICS IP55 Panel mounting frame is designed so that the SINAMICS SDI Pro Operator Panel can be connected to the IP55 converter while retaining the IP55 degree of protection of the converter.

SINAMICS SDI Pro 5.5" door mounting kit



With the optional SINAMICS SDI Pro 5.5" door mounting kit, a SINAMICS SDI Pro 5.5" can be easily installed in a control cabinet door in just a few steps. The door mounting kit includes a metal plate for installing the SINAMICS SDI Pro 5.5" e.g. in a cabinet cutout.¹⁾ In case of door mounting with the SDI Pro 5.5" Operator Panel, the degree of protection IP55/UL type 12 enclosure is achieved for the front side.

¹⁾ The Ethernet connection cable to connect the SDI Pro to the service interface of the converter (X127) or the PROFINET interface (X150) must be ordered separately.

To use the operator panel without an additional power supply at the service interface of the converter (X127; point-to-point connection), an 8-wire RJ45 Ethernet cable is required. Pre-assembled cables can be ordered as an accessory.

SINAMICS G220 built-in and wall-mounted units

Supplementary system components

SINAMICS Smart Adapter

Overview



SINAMICS Smart Adapter

SINAMICS Smart Adapter is a Wi-Fi solution for engineering, service and maintenance tasks for the next generation of SINAMICS converters SINAMICS S200 ¹⁾, SINAMICS S210 (New) ¹⁾ and SINAMICS G220. The adapter is designed to be plugged into and powered from the service interface (X127) on the converter.

Benefits

- Wireless access to the converter-integrated web server via mobile users device
- Wireless access with SINAMICS Startdrive to the SINAMICS converters
- Portable and compact Wi-Fi solution for engineering, service and maintenance tasks for the next generation of SINAMICS converters SINAMICS S200 ¹⁾, SINAMICS S210 (New) ¹⁾ and SINAMICS G220
- Advanced security technology
- Plug and Play interface for easy connectivity
- User friendly

Application

SINAMICS Smart Adapter is used in general industrial applications as an engineering solution for quick commissioning and service.

The adapter is especially valuable in areas, which are difficult to access due to their mechanical mounting locations. The use of SINAMICS Smart Adapter avoids cable clutter and tripping points during commissioning and service tasks and therefore prevents from occasional accidents.

Function

- Easy and quick service and commissioning via a wireless solution using the converter-integrated web server
- Interface that is suitable for the next generation of SINAMICS converters SINAMICS S200 ¹⁾, SINAMICS S210 (New) ¹⁾ and SINAMICS G220 allows power supply of SINAMICS Smart Adapter directly from the converter.
- Advanced security with WPA3 protocol

Selection and ordering data

Description	Article No.
SINAMICS Smart Adapter ¹⁾ Wi-Fi solution for the next generation of SINAMICS converters SINAMICS S200 ¹⁾ , SINAMICS S210 (New) ¹⁾ and SINAMICS G220	6SL4950-0AJ00-0AA0

Technical specifications

SINAMICS Smart Adapter 6SL4950-0AJ00-0AA0	
Supported operating systems	Apple iOS (from 12.2), Android, Microsoft Windows, Mac OS (from 10.15)
Recommended browsers	Google Chrome (from 69.0), Microsoft Edge (from 80.0), Safari, Opera (from 56.0)
Ambient temperature	
• During storage and transport	-40 °C ... +70 °C (-40 ... +158 °F)
• During operation	-10 °C ... +40 °C (-40 ... +104 °F)
Humidity	< 95 %, without condensation
Rated voltage	24 V DC
Wireless technology and frequency range ²⁾	
• At 2.4G:	Wi-Fi 2400 MHz ... 2483.5 MHz
• At 5G:	Wi-Fi 5150 MHz ... 5250 MHz
Wireless modulation type	
• At 2.4G:	802.11 b/g/n
• At 5G:	802.11 a/n
Maximum output power (EIRP)	
• At 2.4G:	17.66 dBm
• At 5G:	14.50 dBm
Type of modulation	DSSS (DBPSK, DQPSK, CCK), OFDM (BPSK, QPSK, 16QAM, 64QAM)
Maximum wireless communication distance	50 m (164 ft)
Maximum antenna gain	
• At 2.4G:	1.2 dBi
• At 5G:	1.6 dBi
Maximum radio frequency output power	
• At 2.4G:	18 dBm
• At 5G:	15 dBm
Degree of protection	IP20/UL Open Type
Dimensions	
• Width	30 mm (1.18 in)
• Height	200 mm (7.87 in)
• Depth	18 mm (0.71 in)
Weight, approx.	0.032 kg (0.071 lb)
Compliance with standards	CE, UKCA, UL, CRC, IMDA, NBTC, KCC, NCC, ICASA, SDPPI, UkrCEPRO, JRF, RED, FCC, IC, WPC, ANATEL, TRA, MIC, SRRC, RCM, ENACOM, SUBTEL, MTC, SDOC, MOC

¹⁾ Release for SINAMICS S200 and SINAMICS S210 (New) available soon.

²⁾ The actual frequency range may vary depending on market.

SINAMICS G220 built-in and wall-mounted units

Supplementary system components

SINAMICS Smart Adapter

Integration

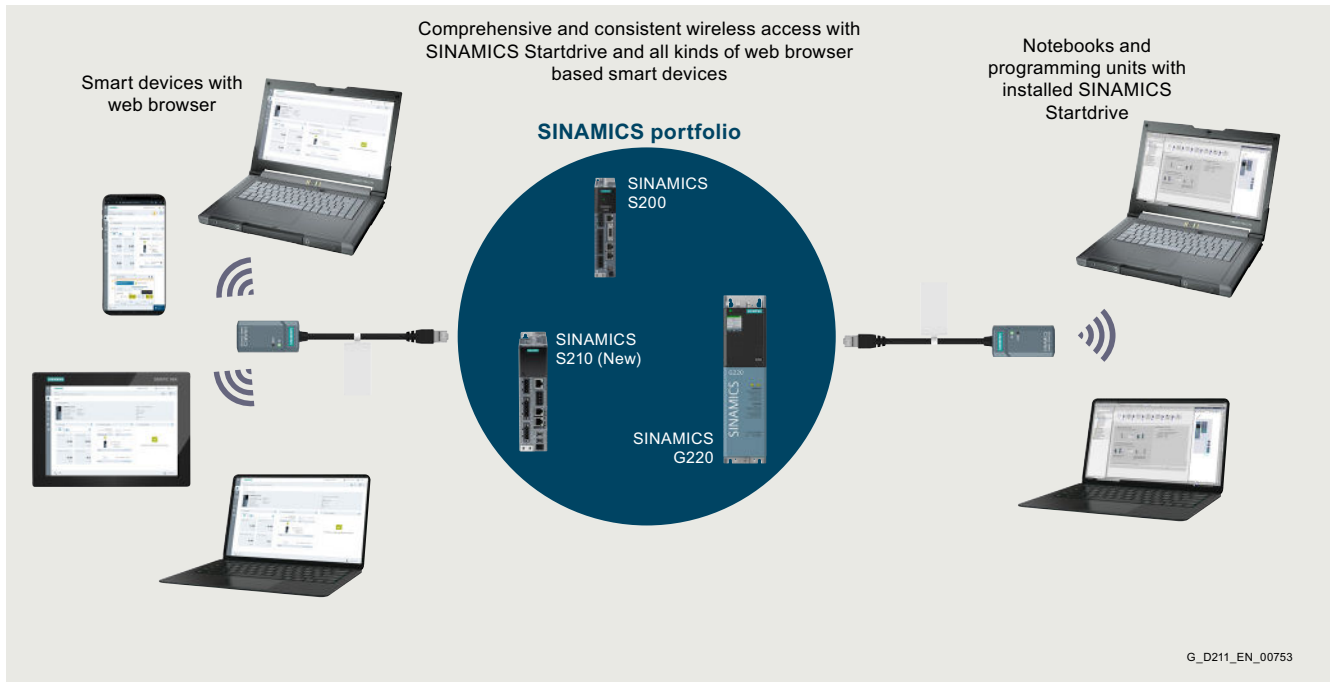

Wireless access with SINAMICS Startdrive via SINAMICS Smart Adapter

SINAMICS G220 built-in and wall-mounted units

Supplementary system components

Encoder system connection > SMC20 Sensor Module Cabinet-Mounted

Overview



SMC20 Sensor Module Cabinet-Mounted

The SMC20 Sensor Module Cabinet-Mounted is required to evaluate the encoder signals of motors without a DRIVE-CLiQ interface. External encoders can also be connected via the SMC20.

The following encoder signals can be evaluated:

- Incremental encoder sin/cos 1 V_{pp}
- Absolute encoder EnDat 2.1
- SSI encoder with incremental signals sin/cos 1 V_{pp} (firmware version 2.4 and later)

The motor temperature can also be sensed using a PTC thermistor KTY84-130, Pt1000¹⁾ or PTC.

Design

The SMC20 Sensor Module Cabinet-Mounted features the following connections and interfaces as standard:

- 1 encoder connection including motor temperature sensing (KTY84-130, Pt1000¹⁾ or PTC) via SUB-D connector
- 1 DRIVE-CLiQ interface
- 1 connection for the electronics power supply via the 24 V DC supply connector
- 1 PE/protective conductor connection

The status of the SMC20 Sensor Module Cabinet-Mounted is indicated via a multi-color LED.

The SMC20 Sensor Module Cabinet-Mounted can be snapped onto a TH 35 standard mounting rail according to EN 60715 (IEC 60715).

The signal cable shield is connected via the encoder system connector and can also be connected to the SMC20 Sensor Module Cabinet-Mounted via a shield connection terminal, e.g. Phoenix Contact type SK8 or Weidmüller type KLBÜ CO 1. The shield connection terminal must not be used as a strain relief mechanism.

Integration

SMC20 Sensor Modules Cabinet-Mounted communicate via DRIVE-CLiQ with selected devices e.g. SINAMICS S110/S120/S150 Control Units and SINAMICS G220 converters with OM-DQ Option Module DRIVE-CLiQ.

Selection and ordering data

Description	Article No.
SMC20 Sensor Module Cabinet-Mounted	6SL3055-0AA00-5BA3
Without DRIVE-CLiQ cable	
Accessories for re-ordering	
Dust protection blanking plugs (50 units)	6SL3066-4CA00-0AA0
For DRIVE-CLiQ port	

For the SINAMICS S150 and SINAMICS S120 Cabinet Modules, the SMC20 Sensor Module Cabinet-Mounted can be ordered as an option by specifying order code **K48**.

Technical specifications

	SMC20 Sensor Module Cabinet-Mounted 6SL3055-0AA00-5BA3
Power requirement, max. at 24 V DC, without taking encoder into account	0.2 A
• Conductor cross-section, max.	2.5 mm ²
• Fuse protection, max.	20 A
Power loss, max.	10 W
Encoders which can be evaluated	<ul style="list-style-type: none"> • Incremental encoder sin/cos 1 V_{pp} • Absolute encoder EnDat 2.1 • SSI encoder with incremental signals sin/cos 1 V_{pp} (firmware version 2.4 and later)
• Encoder supply	5 V DC/0.35 A
• Encoder frequency incremental signals, max.	500 kHz
• Signal subdivision (interpolation), max.	16384 times (14 bits)
• SSI baud rate	100 ... 1000 kBaud
• Cable length to encoder, max.	100 m (328 ft)
PE connection	M4 screw
Dimensions	<ul style="list-style-type: none"> • Width • Height • Depth
• Width	30 mm (1.18 in)
• Height	150 mm (5.91 in)
• Depth	111 mm (4.37 in)
Weight, approx.	0.45 kg (0.99 lb)
Certificate of suitability	cULus

¹⁾ The Pt1000 sensor is not supported when combined with a Control Unit CU305.

SINAMICS G220 built-in and wall-mounted units

Supplementary system components

Encoder system connection > SMC30 Sensor Module Cabinet-Mounted

Overview



SMC30 Sensor Module Cabinet-Mounted

The SMC30 Sensor Module Cabinet-Mounted is required to evaluate the encoder signals of motors without a DRIVE-CLiQ interface. External encoders can also be connected via the SMC30.

The following encoder signals can be evaluated:

- Incremental encoders TTL/HTL with/without open-circuit detection (open-circuit detection is only available with bipolar signals)
- SSI encoder with TTL/HTL incremental signals
- SSI encoder without incremental signals

The motor temperature can also be sensed using a PTC thermistor KTY84-130, Pt1000¹⁾ or PTC.

Design

The SMC30 Sensor Module Cabinet-Mounted features the following connections and interfaces as standard:

- 1 encoder connection including motor temperature sensing (KTY84-130, Pt1000¹⁾ or PTC) either via SUB-D connector or via terminals
- 1 DRIVE-CLiQ interface
- 1 connection for the electronics power supply via the 24 V DC supply connector
- 1 PE/protective conductor connection

The status of the SMC30 Sensor Module Cabinet-Mounted is indicated via a multi-color LED.

The SMC30 Sensor Module Cabinet-Mounted can be snapped onto a TH 35 standard mounting rail in according to EN 60715 (IEC 60715).

The maximum encoder cable length between SMC30 modules and encoders is 100 m. For HTL encoders, this length can be increased to 300 m if the A+/A- and B+/B- signals are evaluated and the power supply cable has a minimum cross-section of 0.5 mm².

The signal cable shield can be connected to the SMC30 Sensor Module Cabinet-Mounted via a shield connection terminal, e.g., Phoenix Contact type SK8 or Weidmüller type KLBÜ CO 1. The shield connection terminal must not be used as a strain relief mechanism.

Integration

SMC30 Sensor Modules Cabinet-Mounted communicate via DRIVE-CLiQ with selected devices e.g. SINAMICS S110/S120/S150 Control Units and SINAMICS G220 converters with OM-DQ Option Module DRIVE-CLiQ.

Selection and ordering data

Description	Article No.
SMC30 Sensor Module Cabinet-Mounted	6SL3055-0AA00-5CA2
Without DRIVE-CLiQ cable	
Accessories for re-ordering	
Dust protection blanking plugs (50 units)	6SL3066-4CA00-0AA0
For DRIVE-CLiQ port	

For the SINAMICS S150 and SINAMICS S120 Cabinet Modules, the SMC30 Sensor Module Cabinet-Mounted can be ordered as an option by specifying order code **K50**.

A second SMC30 can be ordered as an option with the order code **K52** for reliable actual value acquisition when using the Safety Integrated Extended Functions.

Technical specifications

	SMC30 Sensor Module Cabinet-Mounted 6SL3055-0AA00-5CA2
Current requirement, max. at 24 V DC, without taking encoder into account	0.2 A
• Conductor cross-section, max.	2.5 mm ²
• Fuse protection, max.	20 A
Power loss, max.	10 W
Encoders which can be evaluated	<ul style="list-style-type: none"> • Incremental encoder TTL/HTL • SSI encoder with TTL/HTL incremental signals • SSI encoder without incremental signals
• Input current range TTL/HTL	4 ... 20 mA (typ. 10 mA)
• Encoder supply	24 V DC/0.35 A or 5 V DC/0.35 A
• Encoder frequency, max.	500 kHz
• SSI baud rate	100 ... 1000 kBaud
• Resolution absolute position SSI	30 bits
• Cable length, max.	
- TTL encoder	100 m (328 ft) (only bipolar signals permitted ²⁾)
- HTL encoder	100 m (328 ft) for unipolar signals 300 m (984 ft) for bipolar signals ²⁾
- SSI encoder	100 m (328 ft)
PE connection	M4 screw
Dimensions	
• Width	30 mm (1.18 in)
• Height	150 mm (5.91 in)
• Depth	111 mm (4.37 in)
Weight, approx.	0.45 kg (0.99 lb)
Certificate of suitability	cULus

¹⁾ The Pt1000 sensor is not supported when combined with a Control Unit CU305.

²⁾ Signal cables twisted in pairs and shielded.

SINAMICS G220 built-in and wall-mounted units

Notes

2



SINAMICS Selector App Mobile selection guide for frequency converters



Siemens has developed the SINAMICS Selector app as a practical tool for finding article numbers for your SINAMICS converter in the power range from 0.1 kW to 630 kW quickly and easily. Whether for SINAMICS V20, SINAMICS V90, SINAMICS G120C, SINAMICS G120P, SINAMICS G120X, SINAMICS G120, SINAMICS G220, SINAMICS S200 or SINAMICS S210:

The app will provide you with the correct article numbers conveniently. How does it work? Simply select your application, the frequency converter you require, the rated power and device options as well as the necessary accessories. Then you can save your selection and send it by email. The preselection serves as the basis for an order specification with the dealer/Siemens.

You will find free downloads for Android and iOS here:

www.siemens.com/sinamics-selector

3/2	DriveSim Designer
3/4	DriveSim Engineer
3/6	Siemens Product Configurator
3/7	TIA Selection Tool
3/8	SINAMICS web server for SINAMICS G220
3/12	SINAMICS Startdrive commissioning tool

Cybersecurity information

Siemens provides products and solutions with industrial cybersecurity functions that support the secure operation of plants, systems, machines and networks.

In order to protect plants, systems, machines and networks against cyber threats, it is necessary to implement – and continuously maintain – a holistic, state-of-the-art industrial cybersecurity concept.

Siemens' products and solutions constitute one element of such a concept.

Customers are responsible for preventing unauthorized access to their plants, systems, machines and networks. Such systems, machines and components should only be connected to an enterprise network or the internet if and to the extent such a connection is necessary and only when appropriate security measures (e.g. firewalls and/or network segmentation) are in place.

For additional information on industrial cybersecurity measures that may be implemented, please visit www.siemens.com/cybersecurity-industry

Siemens' products and solutions undergo continuous development to make them more secure. Siemens strongly recommends that product updates are applied as soon as they are available and that the latest product versions are used. Use of product versions that are no longer supported, and failure to apply the latest updates may increase customer's exposure to cyber threats.

To stay informed about product updates, subscribe to the Siemens Industrial Security RSS Feed under www.siemens.com/cert

Engineering tools

DriveSim Designer

Overview

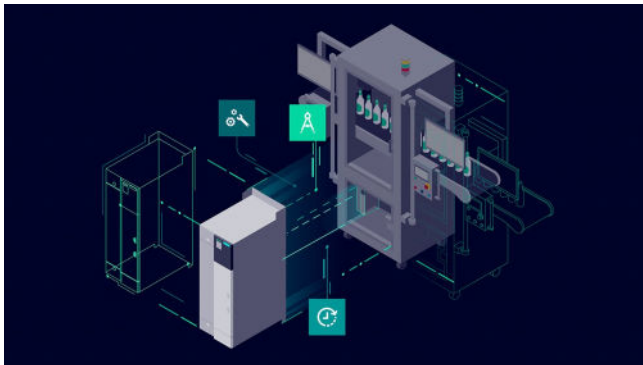

DriveSim Designer provides easy-to-use models for PROFIdrive-enabled SINAMICS converters, so you can create a digital twin of your drive.

The models are validated and tested against real SINAMICS converters and are available in the form of a standardized FMU (Functional Mockup Unit). Therefore, they are compatible with various standard time-based simulation programs such as SIMIT, Simcenter Amesim, ANSYS Twin Builder, MATLAB Simulink or Hopsan.

DriveSim Designer is another element in your engineering toolbox. Together with other virtual Siemens solutions, e.g. SIMATIC S7-PLCSIM Advanced or NX Mechatronics Concept Designer, a consistent model-based development process can be implemented.

Benefits

- Speed up time-to-market for OEMs
- Test validated SINAMICS models under real conditions already at the design or planning stage and make needed adjustments
- Identify issues and improvement capabilities early in the design stage and reduce testing effort to save time and cost
- Download the free-of-charge basic version with reduced functionality set, DriveSim Basic, to try the suitability of our solution before buying it
- The full version DriveSim Designer offers a wide range of additional functionalities to improve the SINAMICS simulation model, e. g. safety or position telegrams
- Valid for the most used Siemens drives

Advantages of DriveSim Designer compared to SIMIT PROFIdrive blocks:

- Increased level of detail due to speed controller, current setpoint filters and internal load model
- Identical parameter values and meaning as in the real SINAMICS device
- Direct reference to SINAMICS documentation
- Basic Safety functions
- Brake control functions for lifting applications
- Validated against the real SINAMICS drive
- No wiring effort to represent functional configurations
- Significant reduction of SIMIT simulation tags (even more is possible if unused in-/ outputs are deselected within the Component Type Editor (CTE))
- Enables simulation of an (internal) two-mass oscillator as application with realistic SINAMICS parameter settings, besides the known limitations by the minimum sample time in SIMIT
- Compatible with every FMU Co-Simulation 2.0 compatible simulation tool

Application

With DriveSim Designer, you can implement three major use cases:

- Providing load characteristics for drive selection and dimensioning
- Virtual commission your PLC already in the design phase
- Test and improve interaction between PLC, drives and application virtually

Use case 1: Dimension and size the correct drive and motor for your application

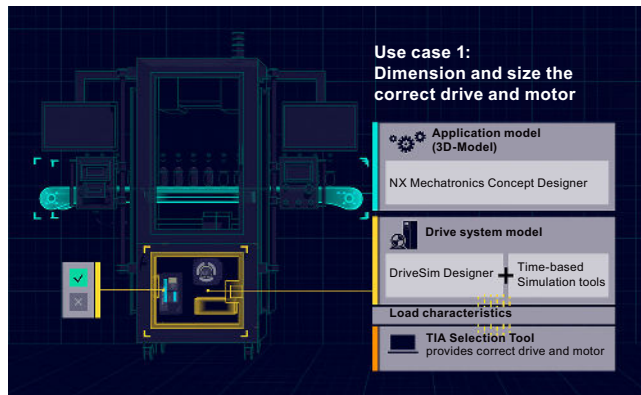

If you are designing a machine, you want to make sure that you select the SINAMICS converter and SIMOTICS motor most suitable for your drive application. As DriveSim Designer is control-unit-agnostic and thus represents a generic drive, you can parametrize it according to the functionality of your application. Running the simulation results in load characteristics, i.e. torque or speed curves over time. You can import these load profiles into TIA Selection Tool to select the suitable Control Unit and dimension the drive to best fit to the demand. So as a result you have well selected SINAMICS converters and SIMOTICS motors with the help of the digital twin.

Use case 2: Virtual commission your drive and PLC early in the design phase

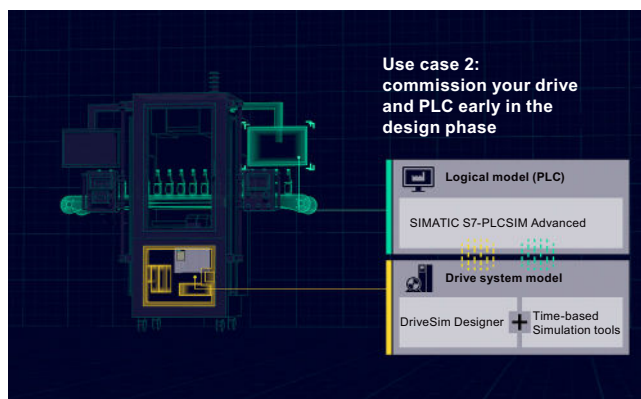

If you are designing a machine, you want to make sure the PLC code works with your SINAMICS drive. After writing the PLC code in TIA Portal, you can connect it via PLCSIM Advanced to any time-based simulation tool (e.g. SIMIT). Integrated into the simulation tool, DriveSim Designer acts as a realistic communication partner for the PLC. Next, you can commission the virtual PLC in TIA Portal as you would do with a real PLC connected to a real drive. Without simulation, you would need to do that on-site. With simulation, you not only save time, but also have the freedom to try out various configurations and optimize your PLC code early in the process.

Application

Use case 3: Combine the application model and automation model with realistic drive system behavior

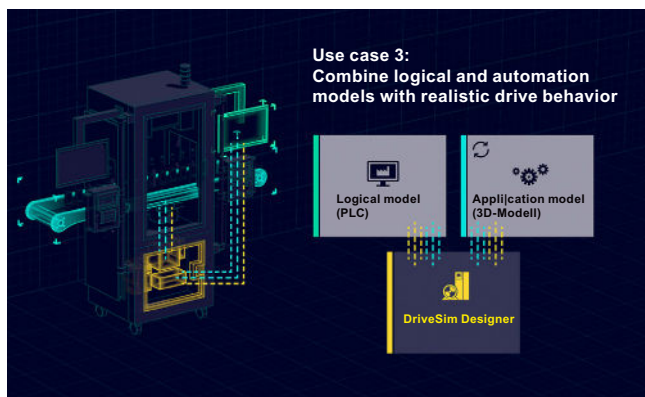

With the third Use case, you can connect a simulation tool such as NX Mechatronic Concept Designer to visualize the mechanical movements of your application. This way, you ensure that the drive behaves according to the desired machine performance. You can test several fault scenarios and optimize the interaction between PLC, application and drive virtually so overall, you can avoid unplanned machine behavior and increase the performance of your setup.

Integration

DriveSim Designer can be run in tools that support FMU 2.0 Co-Simulation Import (<https://fmi-standard.org/tools/>).

The FMU has been tested in the following simulation environments and is available in the attached application examples.

Tool	Manufacturer	DriveSim*** variant	PLC Sim Advanced interface	Notes
SIMIT	Siemens	***.fmu	Yes	<ul style="list-style-type: none"> Permissible configuration: ExternalLoad = 1 & . Speed-Controller = 0 or ExternalLoad = 0 & . Speed-Controller = 1 Simulation with external load can provide wrong results because the minimum possible time step is 1 ms
Simcenter Amesim	Siemens	***_double.fmu	Yes	
MATLAB Simulink	MathWorks	< 2019a ***_unstruct.fmu ≥ 2019a ***.fmu	Yes	
ANSYS Twin Builder	ANSYS	***.fmu	No	
Hopsan	Linköping University	***_double.fmu	No	<ul style="list-style-type: none"> Open Source Install "win64-with_compiler-installer.exe" package

Selection and ordering data

Description	Article No.
DriveSim Designer	9SV1110-3AA00-0AA0

More information

More information is provided on the internet at:
www.siemens.com/drive-virtualization
<https://support.industry.siemens.com/cs/document/109812859>

You can find more videos on the topic at:

- [Simulation of drive systems - Quick, Easy and Validated](#)
- [Simulation of drive systems - An introduction to SINAMICS](#)
- [Getting started with DriveSim Designer](#)
- [How to import DriveSim Designer into SIMIT, Matlab Simulink, Amesim and ANSYS TwinBuilder](#)
- [How to connect DriveSim Designer via PLCsIm Advance to TIA Portal](#)
- [How to use DriveSim Designer for drive sizing with TIA Selection Tool](#)
- [How to visualize drive system behavior in NX Mechatronics Concept Designer](#)

Engineering tools

DriveSim Engineer

Overview

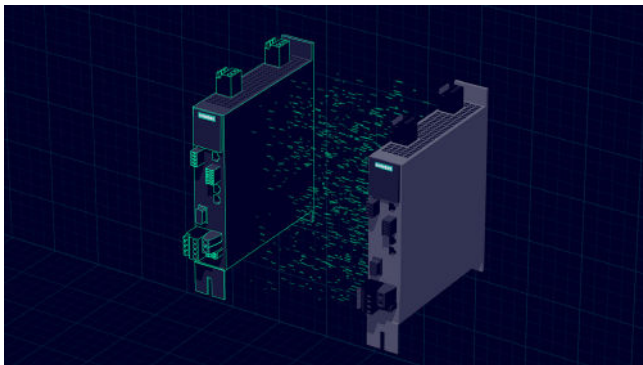

In summary, DriveSim Engineer is a powerful tool that provides a complete digital twin of the next generation of SINAMICS converters SINAMICS G220 and SINAMICS S210 (New), ensuring unparalleled accuracy and reliability. With its seamless integration into the TIA Portal and SINAMICS Startdrive, the advanced level of customization, the detailed and intuitive interface, it is the ultimate solution for optimizing your drive train system.

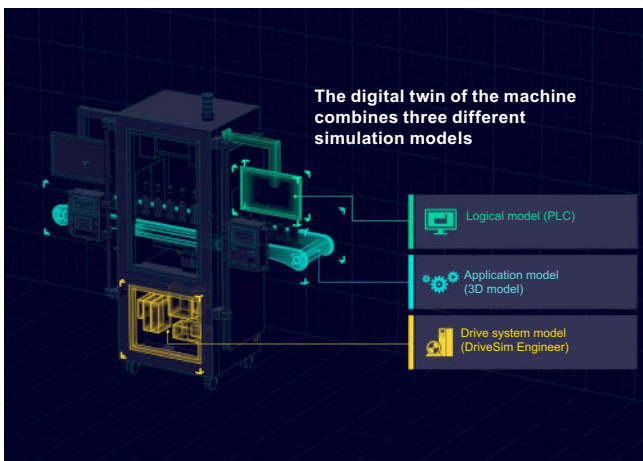

DriveSim Engineer is an innovative solution that combines drive simulation and virtual commissioning. With this powerful combination, you can optimize your drive systems, test and validate your projects and ensure that your drive systems function correctly prior to the installation.

DriveSim Engineer is the ultimate solution for optimizing your drive systems. With its advanced technology and user-friendly interface, you can simulate and optimize the performance of your drive systems to meet the demands of your processes. DriveSim Engineer is the solution you have been searching for to improve efficiency, productivity, as well as the overall performance of your drive systems.

The complete digital twin of the real SINAMICS firmware for the next generation of SINAMICS converters SINAMICS G220 and SINAMICS S210 (New) ensures that all parameters and configurations are identical to those of the real drive, providing unparalleled accuracy and reliability.

DriveSim Engineer is a software-dependent solution that works seamlessly with the TIA Portal and SINAMICS Startdrive, eliminating the need for additional simulation tools. Its low-level interaction with the current control loop of the real drive ensures that the behavior is validated and verified, making it a reliable partner for optimizing your drive train system.

What sets DriveSim Engineer apart is its advanced level of customization and detail, allowing for more accurate testing and optimization of the drive train system. Its intuitive interface enables the fast set-up and configuration of your digital twin as well as the simulation of different operating conditions and scenarios.

Whether you are designing, commissioning or optimizing your drive train system, DriveSim Engineer is the tool you need. Its advanced features and high level of accuracy make it an essential tool for the best possible system performance.

Benefits

- Reduce costs and time: Eliminate the need for on-site visits, reduce costs and speed up the commissioning process.
- Testing and optimization of the drive train system without material damage.
- Improved accuracy: Perform precision simulations and tests on your systems, ensuring that they are optimized before the actual purchase.
- Increased flexibility: Make changes to your systems quickly and easily with flexibility to respond to the changes in your project requirements.
- Train the engineers and new users with the help of the virtual twin acting as a realistic partner.
- Virtual demonstration of the SINAMICS converters (prior to mounting or purchase).
- Diagnose and validate the faults or issues in the real environment and fix them with the help of the simulation without any risk of material damage and save resources (lower maintenance and downtime time, i.e. lower costs) without time pressure on the plant side.
- Identify issues and improvement capabilities early in the design stage and reduce testing effort to save time and cost.
- Valid for the next generation of SINAMICS converters SINAMICS G220 and SINAMICS S210 (New).

Application

DriveSim Engineer can be implemented in three major use cases.

Use case	Old approach	Advantages of the new approach with DriveSim Engineer
Virtual commissioning and engineering of the next generation of SINAMICS converters SINAMICS G220 and SINAMICS S210 (New) prior to the mounting	Commissioning of the converters after mounting or purchase	<ul style="list-style-type: none"> • Saving of resources (lower maintenance and shorter downtime, i.e. lower costs) • No time pressure in the real installation, quick and fast reconfiguration of the system • Improved accuracy of the drive train system in detecting and resolving potential issues • Virtual commissioning helps ensure that the system is future-proof by incorporating the latest technologies and design standards.
Virtual training and demonstration of the next generation of SINAMICS converters SINAMICS G220 and SINAMICS S210 (New) for engineers and new users	Trainings and demonstrations on the plant side (not in advance)	<ul style="list-style-type: none"> • Virtual trainings and demonstrations in advance with the digital twin acting as a realistic partner • Make the changes to your systems quickly and easily. • Show and use different application (drives) just on one computer (no need for demo cases). • Traveling costs for trainings and demonstrations will not rise. Everything can be done virtually and in advance (before the hardware is purchased or released).
Diagnose and validate the faults or issues in the real environment and fix them with the digital twin (optimization of the real machine)	Faults and issues of the system are solved on the plant side	<ul style="list-style-type: none"> • Saving of resources (lower maintenance and shorter downtime, i.e. lower costs) • No time pressure in the real installation, quick and fast reconfiguration of the system • Improved accuracy of the drive train system in detecting and resolving potential issues • Virtual commissioning helps ensure that the system is future-proof by incorporating the latest technologies and design standards.

Integration

DriveSim Engineer is directly integrated in TIA Portal and SINAMICS Startdrive, i.e. different software tools are not necessary. Only the installation of DriveSim Engineer and TIA Portal with SINAMICS Startdrive is required.

Selection and ordering data

Description	Article No.
DriveSim Engineer V1.1 – Perpetual license (unlimited)	9SV1210-4AA00-0AA0
DriveSim Engineer V1.1 – Subscription (1 year license)	9SV1210-3AA00-0AA0

More information

More information is provided on the internet at:
www.siemens.com/global/en/products/drives/digitalization-in-drive-technology/virtualization.html

Engineering tools

Siemens Product Configurator

Overview

The Siemens Product Configurator helps you to configure the optimum drive technology products for a number of applications. The product portfolio comprises the full drive technology range of gearbox, motor, converter and connection system as well as corresponding controller with suitable software license. The intuitive user interface in conjunction with product-specific preliminary selectors makes it simple, fast and efficient to configure products. The result is a bill of materials with extensive documentation consisting of technical data sheets, motor characteristic curves, 2D dimensional drawings / 3D CAD models, EPLAN macros and much more. You can order the products directly by transferring the bill of materials to the shopping cart of SiePortal.



Siemens Product Configurator at a glance

- Quick and easy configuration of drive products and associated components – gearboxes, motors, converters, controllers, connection systems
- Extensive documentation for all products and components, such as
 - Data sheets in up to 12 languages
 - Motor characteristic curves
 - 2D dimensional drawings / 3D CAD models in different formats
 - Terminal box drawing and terminal connection diagram
 - Certificates
 - EPLAN macros
- Ability to order products directly through SiePortal

Access to the Siemens Product Configurator

The Siemens Product Configurator can be accessed without the need for registration or logging in:
www.siemens.com/spc

Overview

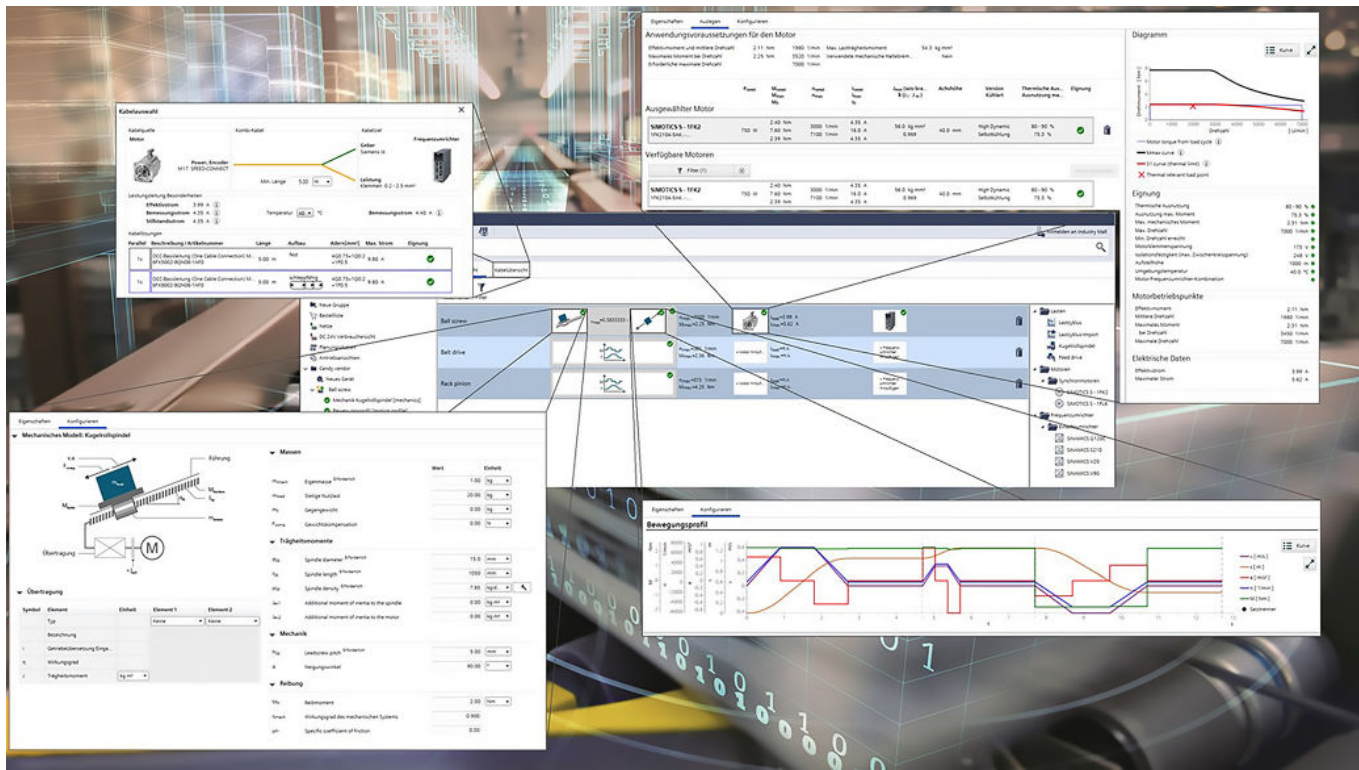

Selection guide and configurator for automation technology

Error-free configuration without expert knowledge through intelligent configurators and selection wizards. Desktop and cloud versions enable cross-team collaboration with maximum flexibility.

There are two versions of the TIA Selection Tool:

- for downloading and executing on Windows PCs (from Microsoft Windows 10)
- One for running from the cloud, which is launched from mobile devices directly in the browser (we recommend Safari, Chrome and Firefox)

Projects stored in the cloud can be edited with both tools. This makes it possible to work on-the-go using a tablet, at home on a PC – and vice versa, or together with colleagues and customers.

In order to use the full functionality, we recommended setting up a SiePortal account for both cases. This gives you access to prices and enables you to save your projects to our cloud.

You can find additional information about the TIA Selection Tool at:

www.siemens.com/tia-selection-tool

Drive dimensioning in the TIA Selection Tool

Application-specific requirements can be determined using drive technology dimensioning in the TIA Selection Tool. This can include motors, gearboxes and converters. The tool supports the configuration and dimensioning of control functions with an open and closed control loop. The technical documentation with features of the technical drive system, as well as a product list for ordering via SiePortal can also be compiled.

You can find more information on the SIZER for Siemens Drives engineering tool at

<https://support.industry.siemens.com/cs/ww/en/ps/13434/dl>

Engineering tools

SINAMICS web server for SINAMICS G220

Overview

Web server for efficient commissioning, diagnostics, maintenance and operator control and monitoring, any time, from anywhere

Thanks to the web server, the SINAMICS G220 drive system offers an efficient commissioning, diagnostics, maintenance option as well as operation and monitoring functions. The user is supported by a help function and additional links to specific product information, downloads, FAQs and manuals.

The web server provides access to a multi-faceted range of new options for commissioning or parameter assignment, drive diagnostics, remote maintenance as well as operator control and monitoring for any networked PC with a web browser or for tablets and smartphones (via a separate WLAN access point, such as SINAMICS Smart Adapter).

The following provides an insight into the functionality offered.

The start screen offers a quick overview of the state of the drive

- Drive type, connected motor as well as the article number and installed firmware
- Important drive parameters show the operating state (can be configured)
- The connection overview provides information about the status of the connections (operating unit - converter - motor)
- Overview of all pending fault and warning messages

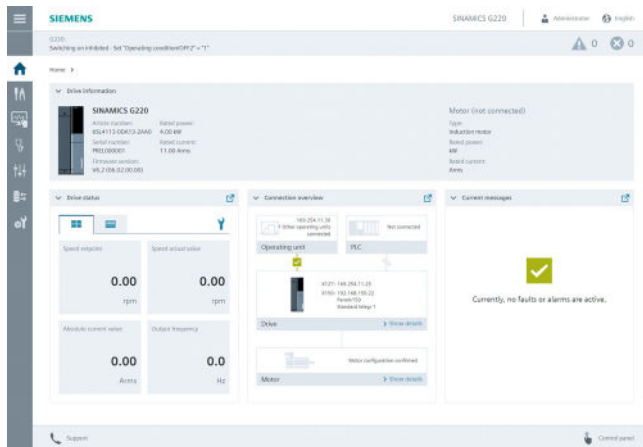

Start screen of the web server integrated into SINAMICS G220

Commissioning

- In the quick commissioning, the most important drive characteristics are defined, e.g. motor data, limit values and the configuration of the inputs and outputs. If an motor-side filter is installed, the extended commissioning has to be used.
- In the extended commissioning, drive options and functions are defined to suit your application. The extended commissioning includes all the settings of the quick commissioning as well as additional options and functions.
- Safety Integrated commissioning guides you through the commissioning of the Safety Integrated functions of the converter.

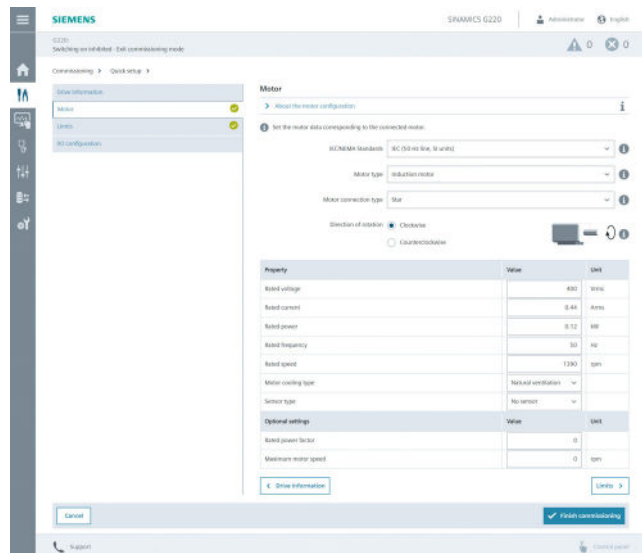

Quick commissioning with open dialog showing the set motor data

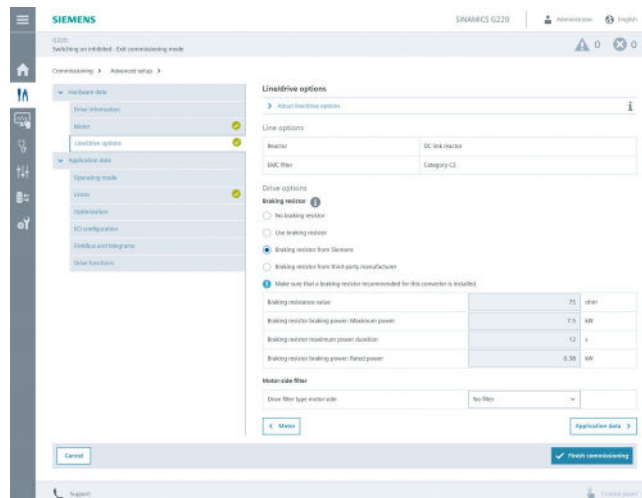

Extended commissioning with open dialog for the line/drive options

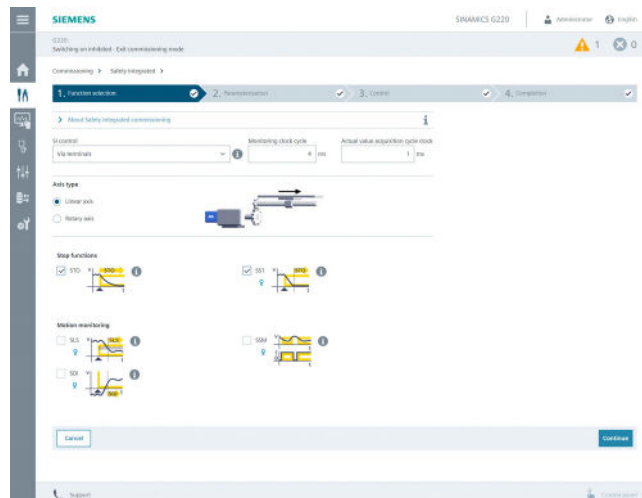

Safety Integrated assistant

Overview

Operator control and monitoring

- Configurable drive status with value or trend display
- Status of the inputs and outputs
- Drive traversing via the control panel, which can be freely positioned on the screen

Diagnostics

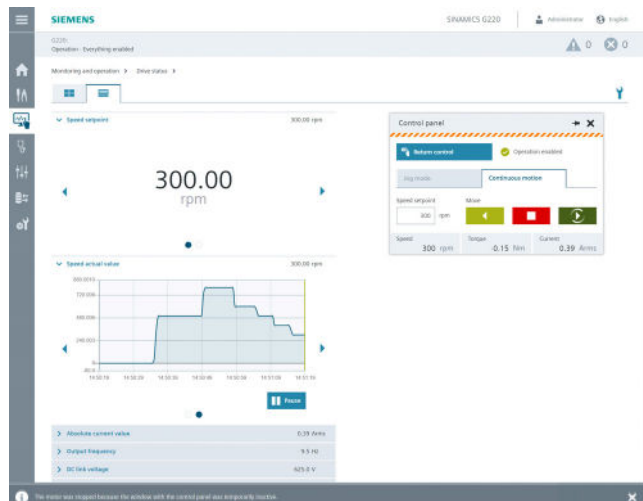

Operator control and monitoring of the drive with the help of the drive status and control panel

- Evaluation of warnings and fault messages
- Evaluation of system events (diagnostic buffer)
- Analysis of the safety status
- Connection overview, diagnostics of the drive communication and control and status words

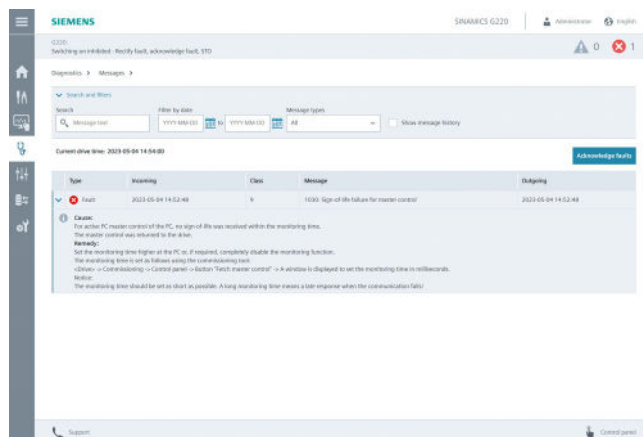

Alarm view with convenient search and filter functions

Service and maintenance functions

- Monitor and adjust drive parameters
- Convenient creation and management of signal interconnections
- Create, import and export user-specific parameter lists
- Back up and restore the drive configuration
- Perform firmware update, also via the network
- Manage software licenses
- Configure basic settings for the drive and web server (e.g. date and time of the drive)
- Configure and manage user accounts and access controls (UMAC)

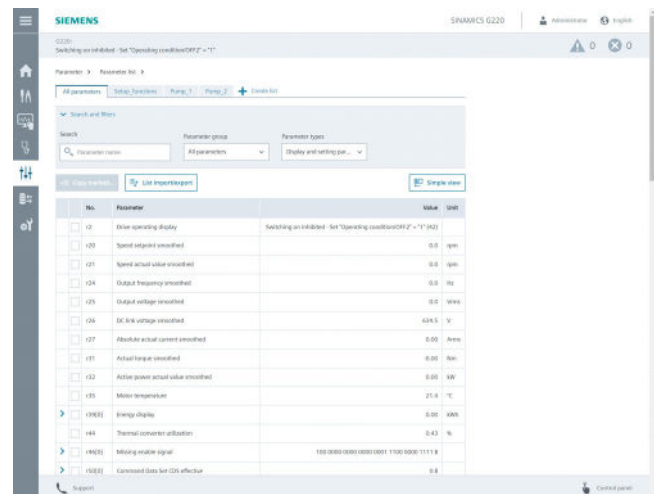

Parameter list for quick access to drive parameters, also via user-defined parameter lists

Support

- Operator support with comprehensive information about the drive and user interface
- Easy access to product information such as FAQs, software downloads, manuals and certificates
- When storing the html documentation on the drive memory card, the user manual can be accessed in a context-sensitive manner from the user interface

Engineering tools

SINAMICS web server for SINAMICS G220

Overview

Support✕

Links to the Siemens Industry Online Support

▼ **General links**

[Product page SINAMICS G220](#)
[Siemens Industry Online Support - Home](#)

▼ **Product-specific links for SINAMICS G220**

[Product Support](#)
[FAQs](#)
[Software downloads](#)
[Manuals / Operating Instructions](#)
[Test certificates / certificates](#)
[Product update](#)

Data matrix codes for the Siemens Industry Online Support App

▶ [Siemens Industry Online Support App](#) ⓘ

Component

Type: SINAMICS G220
Article number: 6SL4113-0DA13-2AA0
Serial number: PREL000001
Firmware version: 06.02.00.00

OK

Support dialog for quick access to product-specific information

Benefits

Simple and fast commissioning

- Installation of additional commissioning software is not required. Tools required for the commissioning are ready to use via the integrated web server.
- Standard pages to set thresholds and onboard inputs
- Guided parameterization of Safety Integrated functions
- Extensive online help with context-sensitive access to the Operating Instructions (memory card required)

Shorter machine downtimes

- Quick overview of the current configuration and the state of the drive
- Efficient diagnostics and maintenance
- Understandable diagnostic information and messages, including the causes of issues and possible remedies, are displayed in plain text in multiple languages
- Context-sensitive help with optional access to the web-based device documentation provides quick help with questions about drive functions

Convenient service and maintenance functions

- Quick backup and restoration of the drive data
- Convenient firmware update, also via the network
- Convenient access to drive parameters and their signal interconnections
- User-defined parameter lists that focus on what matters
- Easy and efficient handling of the parameter list by using search functions and filters (e.g. parameter groups, parameter types)
- Easy exchange with operating personnel by importing/exporting user-defined parameter lists.
- User-defined parameter lists can be exchanged between the SINAMICS Startdrive and the web server.

Direct language selection

- English, French, German, Italian, Spanish, Chinese Simplified

Accessibility

- Via all LAN or PROFINET interfaces
- Use of mobile devices (e.g. notebooks/tablets and smartphones) via WLAN e.g. with SINAMICS Smart Adapter or a separate access point
- Access to the web server via PCs/notebooks, SIMATIC HMI (> 10"), smartphones/tablets with a Chromium-based internet browser

Access security

- Protection against unauthorized access to the drive functions and data
- Convenient user administration that supports a roles concept
- Easy set-up and management of user accounts

Application

The web server is ideal for applications not requiring any special commissioning software or version dependencies. Commissioning, diagnostics and maintenance as well as operator control and monitoring are possible both locally and remotely, provided appropriate security measures are applied.

Integration

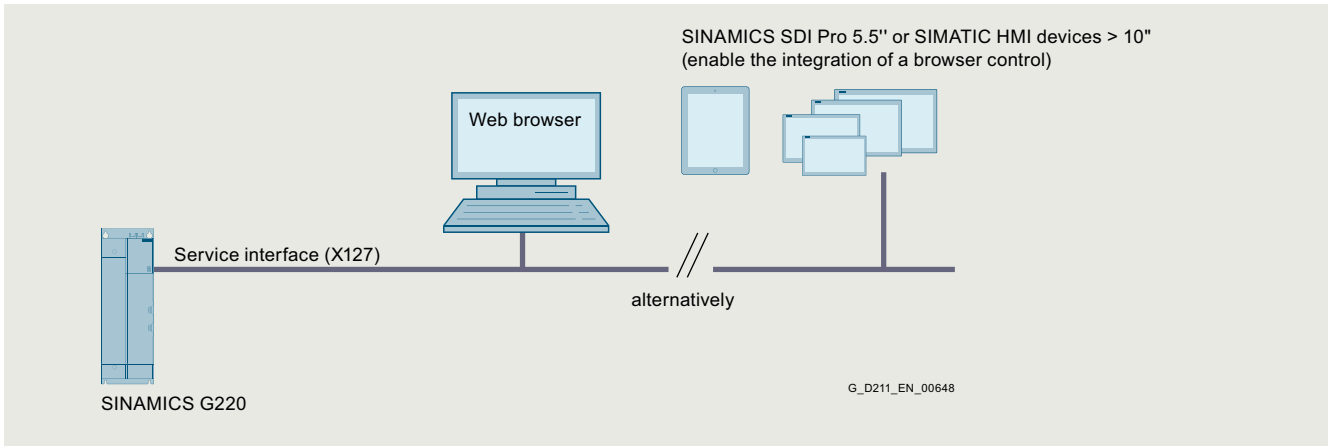

Integration of the SINAMICS web server based on the example of a SINAMICS G220 and the service interface (X127)

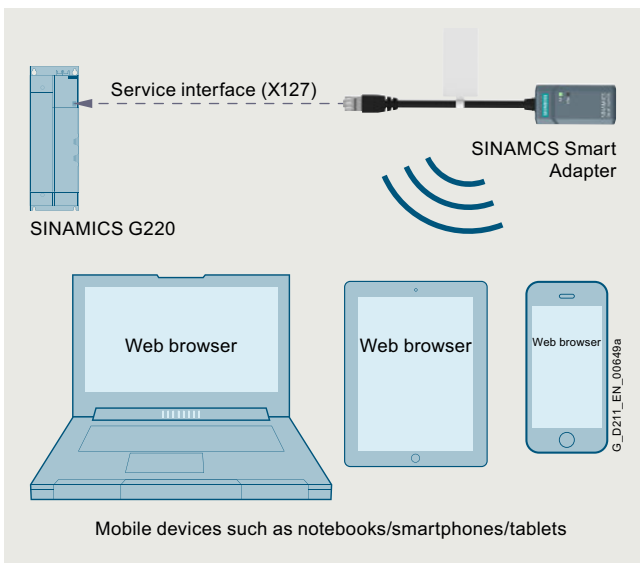

Wireless access to the web server via the service interface (X127) of the SINAMICS G220 with the help of the SINAMICS Smart Adapter

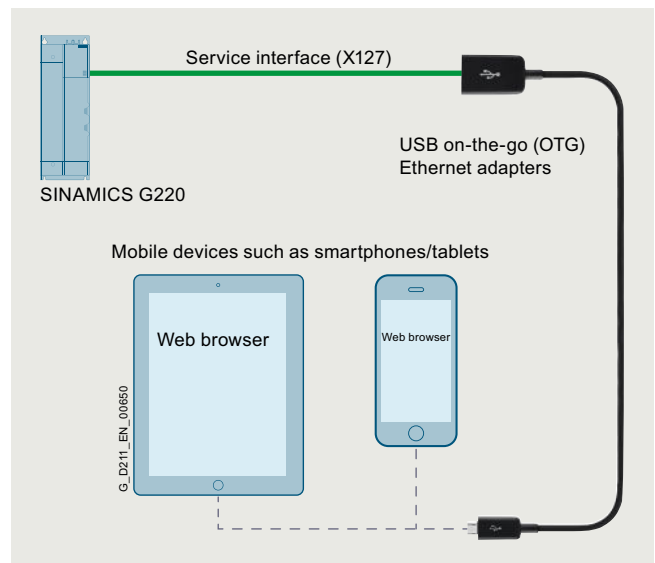

Access to the web server via the service interface (X127) of the SINAMICS G220 with the help of a USB on-the-go (OTG) Ethernet adapter

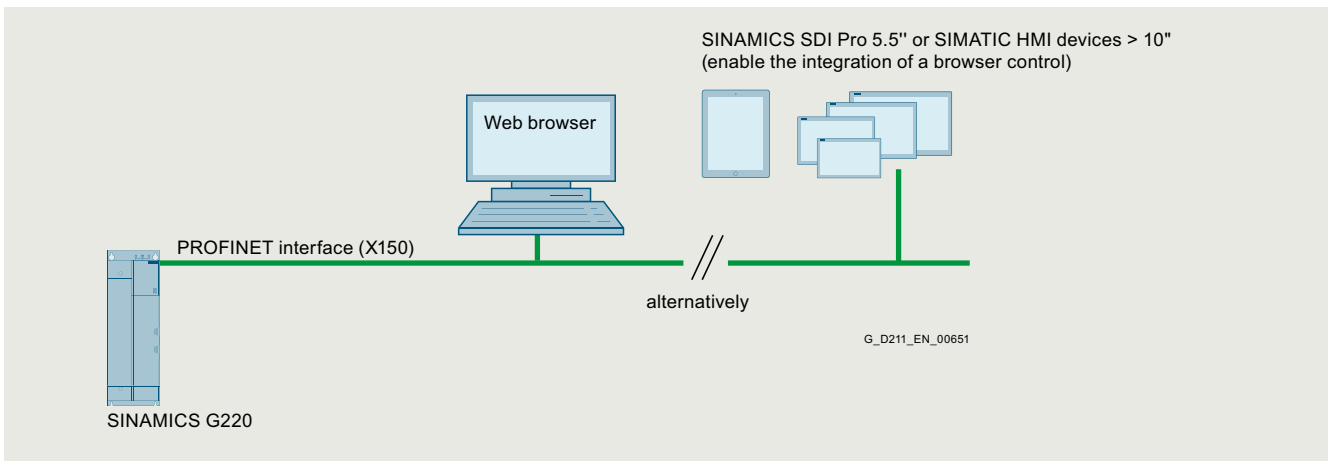

Integration of the SINAMICS web server based on the example of a SINAMICS G220 and the PROFINET interface (X150) as connected web client (e.g. PC, SIMATIC HMI etc.)

Engineering tools

SINAMICS Startdrive commissioning tool

Overview

SINAMICS Startdrive is integrated in the TIA Portal and is a tool for the configuration, commissioning and diagnostics of the SINAMICS family of converters.

The SINAMICS Startdrive commissioning tool has been optimized with regard to user friendliness and consistent use of the TIA Portal benefits of a common working environment for PLC, HMI and drives. Time-saving and guided step-by-step commissioning with maximum flexibility is complemented by user-friendly graphic function views for all drive functions, including functional safety (Safety Integrated) and drive-based technology functions (e.g. EPOS). The automatic message display, the powerful real-time trace and the context-sensitive online help make converter diagnostics very easy.

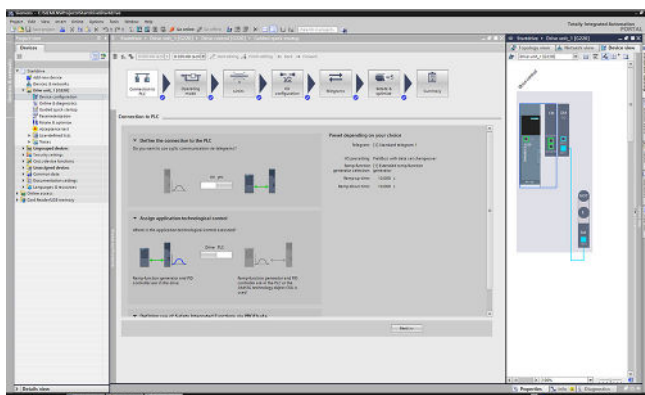

The software packages based on the TIA Portal are harmonized with each other and offer important benefits, the main advantage being a shared project storage. The TIA Portal enables simple integration of SINAMICS converters in your automation solution. Thanks to the standardization of operator actions and the integration in general TIA Portal operating concepts (e.g. UMAC, Openness) as well as standard TIA Portal functions (e.g. Undo/Redo), familiarization is easy both for drive experts as well as SIMATIC users. Special focus is placed on the interaction between SIMATIC and SINAMICS, especially when connecting the SINAMICS drives to SIMATIC technology objects.

Integration

Supported frequency converters

SINAMICS Startdrive Basic enables complete commissioning, diagnostics, parameterization, optimization and connection to the PLC for the following SINAMICS converters integrated in SINAMICS Startdrive:

- SINAMICS G120, G120C, G120D, G120P
- SINAMICS G115D
- SINAMICS G130, G150
- SINAMICS G220 (as of V18 SP2 Update 1)
- SINAMICS S120¹⁾, S150
- SINAMICS S210 and SINAMICS S210 (New) (as of V18 SP1)
- SINAMICS S200 (as of V18 SP2)
- SINAMICS MV

¹⁾ Including SINAMICS S220 Smart Line Modules in booksize format as of SINAMICS Startdrive V17 Update 1.

SINAMICS Startdrive Advanced

With SINAMICS Startdrive Advanced (available as of V15) you benefit from powerful engineering functions that save you considerable time and ultimately costs.

- Safety acceptance test:
 - Guided acceptance test wizard for all drive-based Safety Integrated functions
 - Automatic and safety function-specific generation of traces to analyze the machine behavior
 - Generation of an acceptance report as Excel file (xlsx format, can also be used with OpenOffice)
 - Safety Activation Test
- Improved optimization options in the drive: Extended measuring functions (available for CU320-2 PN/DP and CU310-2 PN as of V5.2 SP3, SINAMICS S210 (New) as of V6.1 and SINAMICS S200 as of V6.2), long-term trace
- Also contains all Startdrive Basic functions
- Only license key required, no additional installation

New in V19

Startdrive Basic V19

- Support of the shared device functionality for SINAMICS S210, S120, G220 for separate control of the drives by separate controllers
- Improvement of the library function for individual drive objects in the multi-axis system
- Integration of the decentralised SINAMICS S120M drives
- Unit switching (SI/US/%) for SINAMICS CU3x0-2 based drives (from V19 SP1)
- Integration of the drive version V6.3 for SINAMICS S200 and SINAMICS S210 (New):
 - Introduction of the positioning function EPOS for SINAMICS S210 (New)

Startdrive Advanced V19

- Long-term trace functionality for CU320-2 PN/DP and CU310-2 PN-based drive units

Installation versions

SINAMICS Startdrive can be installed as an optional package to SIMATIC STEP 7 or as a stand-alone application (without SIMATIC STEP 7).

System requirements

The following table shows the recommended hardware and system equipment for the operation of SINAMICS Startdrive.

Hardware	Recommendation
Computer	As of SIMATIC FIELD PG M6 Comfort (or comparable PC)
Processor	Intel Core i5-8400H (2.5 ... 4.2 GHz; 4 cores + hyper-threading; 8 MB Smart Cache)
RAM	16 GB or more (32 GB for large projects)
Hard disk	SSD with at least 50 GB available memory
Screen resolution	15.6" Full HD display (1920 × 1080 or larger)
Operating systems	<ul style="list-style-type: none"> • Microsoft Windows 10 (64 bit) <ul style="list-style-type: none"> - Windows 10 Professional Version 22H2 - Windows 10 Enterprise 21H2, 22H2 - Windows 10 Enterprise 2016 LTSC - Windows 10 Enterprise 2019 LTSC - Windows 10 Enterprise 2021 LTSC • Microsoft Windows 11 (64 bit) <ul style="list-style-type: none"> - Windows 11 Home Version 21H2, 22H2 - Windows 11 Professional Version 21H2, 22H2 - Windows 11 Enterprise 21H2, 22H2 • Microsoft Windows Server (64 bit) <ul style="list-style-type: none"> - Windows Server 2016 Standard (full installation) - Windows Server 2019 Standard (full installation) - Windows Server 2022 Standard (full installation)

Integration

Compatibility with other products

- SINAMICS Startdrive V19 operates with STEP 7, WinCC and Scout TIA V19 in one framework
- SINAMICS Startdrive V19 can be installed on the same computer in parallel with other versions of SINAMICS Startdrive V12 to V18
- SINAMICS Startdrive can be installed on the same computer as SINAMICS MICROMASTER STARTER

Supported virtualization platforms

SINAMICS Startdrive can be installed in a virtual machine. For this purpose, one of the following virtualization platforms in the specified version or a newer version can be used:

- VMware vSphere Hypervisor (ESXi) 6.7
- VMware Workstation 15.5.0
- VMware Player 15.5.0
- Microsoft Hyper-V Server 2019

Supported safety programs

The following safety programs have been tested with SINAMICS Startdrive V19:

- Virus scanners:
 - Symantec Endpoint Protection 14.6
 - Trend Micro OfficeScan 14.0
 - McAfee Endpoint Security (ENS) 10.6 and 10.7
 - Microsoft Defender
 - Qihoo 360 "Safe Guard 12.1" + "Virus Scanner"
- Encryption software:
 - Microsoft Bitlocker
- Host-based Intrusion Detection System
 - McAfee Application Control 8.3.3

Selection and ordering data

Description	Article No.
SINAMICS Startdrive Basic V19 SP1 commissioning tool Single license and certificate of license English, French, German, Italian, Spanish, Chinese Simplified • Software download (email address required for delivery)	6SL3072-4KA02-0XG0
SINAMICS Startdrive Advanced V19 SP1 commissioning tool License key (floating license) English, French, German, Italian, Spanish, Chinese Simplified • On DVD-ROM with license key on USB flash drive • Software download incl. license key (email address required for delivery)	6SL3072-4KA02-0XA5 6SL3072-4KA02-0XG5
Upgrade SINAMICS Startdrive Advanced V15 ... V18 to V19 SP1 • On DVD-ROM with license key on USB flash drive • Software download incl. license key (email address required for delivery)	6SL3072-4KA02-0XE5 6SL3072-4KA02-0XK5
Software Update Service with SINAMICS Startdrive Advanced in the TIA Portal Delivery is performed according to the number of ordered SUS products (e.g. 10 upgrade license keys (floating license) with 10 DVD-ROMs, 10 USB flash drives, etc.) • On DVD-ROM with upgrade license key on USB flash drive • Software download incl. license key (email address required for delivery)	6SL3072-4AA02-0XL8 6SL3072-4AA02-0XY8

Accessories

Depending on the version of the Control Unit (CU), the Control Unit of the drive unit can communicate with the programming device (PG) or PC via PROFIBUS or PROFINET/Ethernet or via a serial interface. The following accessories are available for the particular drive system as listed in the following table.

Recommended accessories For communication between the drive unit and the programming device or PC	
Description	Article No.
SINAMICS G220 • Wi-Fi SINAMICS Smart Adapter ¹⁾ Wi-Fi solution for the next generation of SINAMICS converters SINAMICS S200 ¹⁾ , SINAMICS S210 (New) ¹⁾ and SINAMICS G220	6SL4950-0AJ00-0AA0

More information

The SINAMICS Startdrive Basic commissioning tool is available free on the internet at www.siemens.com/startdrive

¹⁾ Release for SINAMICS S200 and SINAMICS S210 (New) available soon.

Engineering tools

Notes

3

Services and documentation

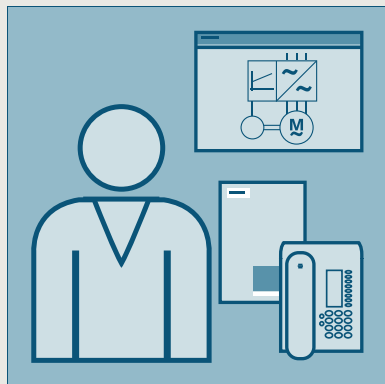

4/2	Partner
4/3	Industry Services
4/4	Industry Services – Portfolio overview
4/5	Online Support
4/6	Training
4/6	SITRAIN
4/8	Training courses for SINAMICS low-voltage converters
4/9	SINAMICS G220 training case
4/10	Control cabinets
4/12	Applications
4/13	Field and maintenance services
4/13	General overhaul
4/13	Function check
4/14	Spare parts services
4/14	Delivery of spare parts
4/15	Delivery as exchange product
4/15	Component upgrade service
4/16	Return of diagnostic parts
4/16	Stock reduction in spare parts store
4/16	Extended spare part availability
4/17	Repair services
4/18	Spares on Web
4/19	Drives Options Partner
4/20	mySupport documentation
4/21	Documentation
4/21	General documentation
4/22	SINAMICS G220 documentation

Services and documentation

Overview

Partner at Siemens

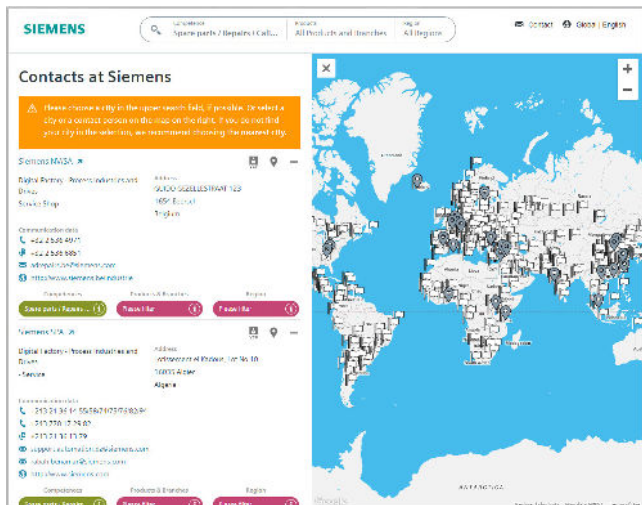

At your service locally, around the globe for consulting, sales, training, service, support, spare parts on the entire portfolio of Siemens.

Your partner can be found in our Personal Contacts Database at: www.siemens.com/automation-contact

You start by selecting

- the required competence,
- products and branches,
- a country and a city

or by a

location search or free text search.

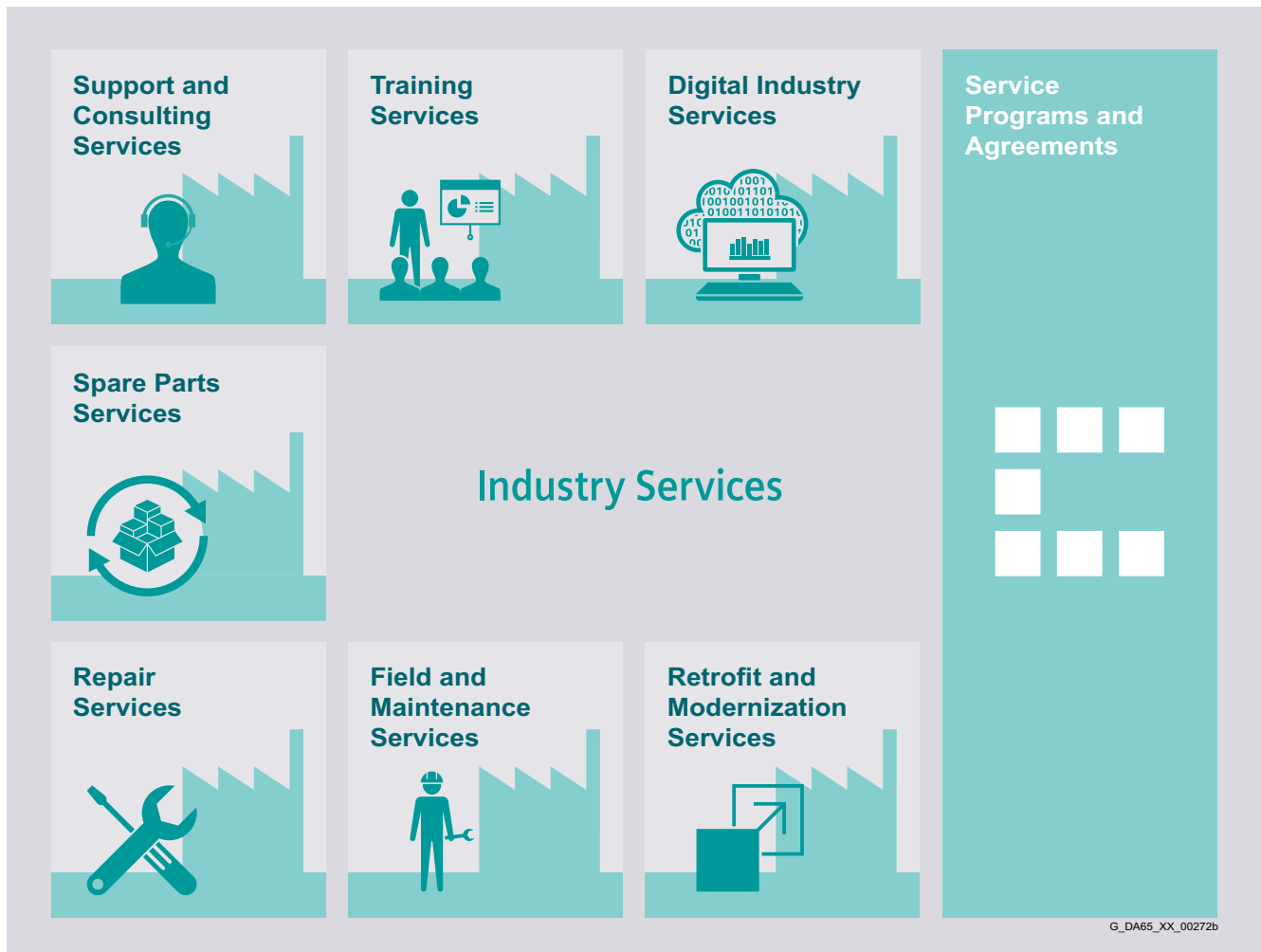
Overview

Keep your business running and shaping your digital future – with Industry Services

Optimizing the productivity of your equipment and operations can be a challenge, especially with constantly changing market conditions. Working with our service experts makes it easier. We understand your industry's unique processes and provide the services needed so that you can better achieve your business goals.

You can count on us to maximize your uptime and minimize your downtime, increasing your operations' productivity and reliability. When your operations have to be changed quickly to meet a new demand or business opportunity, our services give you the flexibility to adapt. Of course, we take care that your production is protected against cyber threats. We assist in keeping your operations as energy and resource efficient as possible and reducing your total cost of ownership. As a trendsetter, we ensure that you can capitalize on the opportunities of digitalization and by applying data analytics to enhance decision making: You can be sure that your plant reaches its full potential and retains this over the longer lifespan.

You can rely on our highly dedicated team of engineers, technicians and specialists to deliver the services you need – safely, professionally and in compliance with all regulations. We are there for you, where you need us, when you need us.

www.siemens.com/digital-enterprise-services

Services and documentation

Industry Services

Industry Services – Portfolio overview

Overview



Digital Industry Services

Digital Industry Services make your industrial processes transparent to gain improvements in productivity, asset availability, and energy efficiency.

Production data is generated, filtered and translated with intelligent analytics to enhance decision-making.

This is done whilst taking data security into consideration and with continuous protection against cyber-attack threats.

www.siemens.com/digital-enterprise-services

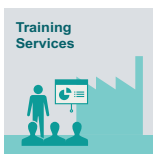

Training Services

From the basics and advanced to specialist skills, SITRAIN courses provide expertise right from the manufacturer – and encompass the entire spectrum of Siemens products and systems for the industry.

Worldwide, SITRAIN courses are available wherever you need a training course in more than 170 locations in over 60 countries.

<https://support.industry.siemens.com/cs/ww/en/sc/2226>



Support and Consulting Services

Industry Online Support site for comprehensive information, application examples, FAQs and support requests.

Technical and Engineering Support for advice and answers for all inquiries about functionality, handling, and fault clearance. The Service Card as prepaid support for value added services such as Priority Call Back or Extended Support offers the clear advantage of quick and easy purchasing.

Information & Consulting Services, e.g. SIMATIC System Audit; clarity about the state and service capability of your automation system or Lifecycle Information Services; transparency on the lifecycle of the products in your plants.

<https://support.industry.siemens.com/cs/ww/en/sc/2235>



Spare Parts

Spare Parts Services are available worldwide for smooth and fast supply of spare parts – and thus optimal plant availability. Genuine spare parts are available for up to ten years. Logistic experts take care of procurement, transport, custom clearance, storage and order management.

Reliable logistics processes ensure that components reach their destination as needed.

Since not all spare parts can be kept in stock at all times, Siemens offers a preventive measure for spare parts provisioning on the customer's premises with optimized **Spare Parts Packages** for individual products, custom-assembled drive components and entire integrated drive trains – including risk consulting.

Asset Optimization Services help you design a strategy for parts supply where your investment and carrying costs are reduced and the risk of obsolescence is avoided.

<https://support.industry.siemens.com/cs/ww/en/sc/2110>



Repair Services

Repair Services are offered on-site and in regional repair centers for fast restoration of faulty devices' functionality.

Also available are extended repair services, which include additional diagnostic and repair measures, as well as emergency services.

<https://support.industry.siemens.com/cs/ww/en/sc/2154>



Field and Maintenance Services

Siemens specialists are available globally to provide expert field and maintenance services, including commissioning, functional testing, preventive maintenance and fault clearance.

All services can be included in customized service agreements with defined reaction times or fixed maintenance intervals.

<https://support.industry.siemens.com/cs/ww/en/sc/2265>



Retrofit and Modernization Services

Provide a cost-effective solution for the expansion of entire plants, optimization of systems or upgrading existing products to the latest technology and software, e.g. migration services for automation systems.

Service experts support projects from planning through commissioning and, if desired over the entire extended lifespan, e.g. Retrofit for Integrated Drive Systems for an extended lifetime of your machines and plants.

<https://support.industry.siemens.com/cs/ww/en/sc/2286>



Service Programs and Agreements

A technical Service Program or Agreement enables you to easily bundle a wide range of services into a single annual or multi-year agreement.

You pick the services you need to match your unique requirements or fill gaps in your organization's maintenance capabilities.

Programs and agreements can be customized as KPI-based and/or performance-based contracts.

<https://support.industry.siemens.com/cs/ww/en/sc/2275>

Overview

Online Support – fast, intuitive, whenever you want, wherever you need



Web
www.siemens.com/online-support

App

GET IT ON Google Play | GET IT ON App Store | Download on the Microsoft Store

Scan the QR code for information on our Online Support app.



- FAQ / Application examples**
Information about industrial products, programming and configuration as well as application examples
- Technical information**
Videos, documentation, manuals, updates, product notes, compatibility tool, certificates, planning data such as dimensional drawings, product data, 3D models
- Forum**
Exchange information and experience with other users and experts

Online Support for Siemens Industry Products

Siemens Industry and Online Support with some 1.7 million visitors per month is one of the most popular web services provided by Siemens. It is the central access point for comprehensive technical know-how about products, systems and services for automation and drives applications as well as for process industries.

In connection with the challenges and opportunities related to digitalization you can look forward to continued support with innovative offerings.

Services and documentation

Training

SITRAIN

Introduction

Learn the way you like it – with SITRAIN

SITRAIN imparts a wide range of technical knowledge for all industries and applications. Our offering is oriented toward the needs of learners and the demands of innovative companies. Get pleasure out of learning - thanks to innovative learning methods, personal support, and knowledge that will help you in your work and further development. For successful, flexible, and continuous learning.

Education and training directly from the manufacturer

SITRAIN provides you with training from the industrial product and solution portfolio from Siemens and benefits from 30 years of expertise in technical training. Take a look at the many options for expanding your knowledge with SITRAIN and find the course that meets your needs! The following training and further education units are available to you for your individual knowledge building:



Industrial Automation Systems SIMATIC

Training available for: SIMATIC S7-1500, TIA Portal, SIMATIC S7-300/400, SIMATIC S7-1200



Drive Technology

Training available for: SINAMICS S120 and SINAMICS G120 low-voltage converters, SINAMICS G130 / G150 / G180 / S150



SINUMERIK CNC automation system

Training available for: SINUMERIK 840D, SINUMERIK 840D sl and SINUMERIK ONE



Process Control Systems

Training available for: SIMATIC PCS 7, SIMATIC PCS neo



Digital Enterprise

Training available for: Openness, SIMIT, OPC UA, Industrial Edge, Virtual commissioning



Industrial Communications

Training available for: PROFINET, SCALANCE, RUGGEDOM, Industrial Ethernet, Fieldbus communication, Industrial Security, Remote communication



Identification and Locating

Training available for: RFID, RTLS-Systems



Operator Control and Monitoring Systems

Training available for: SIMATIC WinCC Unified in TIA Portal, SIMATIC WinCC in TIA Portal, SIMATIC WinCC V7x



Motion Control System SIMOTION

Training available for: SIMOTION (Programming, Commissioning, Diagnostics, Service)



Smart Infrastructure

Training available for: SIRIUS, SENTRON, SIVACON, ALPHA, SIMOCODE, Circuit breakers



Process Analytics & Instrumentation

Training is available for process analytics and instrumentation, explosion protection, process gas chromatographs



Additional training offer

SIMOVE with Automated Guided Vehicles (AGV), SIPLUS CMS, Guidelines and standards for control cabinets

Introduction

Different learning formats and methods for maximum learning success

With our SITRAIN training formats, you learn in the way that best suits your preferences and routine. You decide whether you would rather take online training or face-to-face training. It is up to you whether you would like to study on demand or at fixed times.

With a personal learning consultant, in the team, or on your own – you can explore all the possibilities.

Discover our three learning formats:



Learning Event

SITRAIN Learning Events are the perfect choice when you want to achieve a defined learning goal in the shortest possible time. You learn in a protected learning environment outside of the daily work routine under the guidance of a learning consultant - virtually, in the training center, or at your company.



**Learning Membership
SITRAIN Access**

With SITRAIN access, you enter a world of extensive and constantly expanding self-study units on our digital learning platform for industry. With SITRAIN access, you can implement a modern learning culture in your team or company with independent and continuous learning.



Learning Journey

The Learning Journey is the perfect combination of units taken live and self-study units for sustainable learning success. The modular approach enables simple integration into your daily work. This also includes one-year membership for using the SITRAIN access digital learning platform.



Live

Learn together with others, simultaneously and guided by a learning consultant. Online, in the SITRAIN training center or at your company.

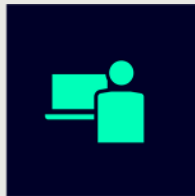

Self-reliant

Expand your knowledge self-determined with industry learning and work on your learning units at your own pace and according to your own schedule.

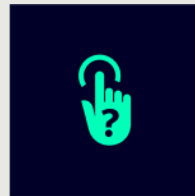

On demand

Get the knowledge you need, exactly when you need it. Be it to answer a current question or to work on a special topic.

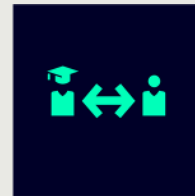

Individual

Talk directly with the learning consultant, clarify detailed questions and get personal coaching for transferring the learned topics to your own application.



Training cases catalog

<https://www.siemens.com/sitrain-catalog-training-cases>

www.siemens.com/sitrain

Find your local offer here



Services and documentation

Training

Training courses for SINAMICS low-voltage converters

Overview

Training courses for SINAMICS drive system



This provides an overview of the training courses available for the SINAMICS drive system.

The courses are modular in design and are directed at a variety of target groups as well as individual customer requirements.

The system overview will acquaint decision-makers and sales personnel with the system very quickly.

The engineering course provides all the information you need to configure the drive system.

The courses dedicated to diagnostics and servicing, parameterization and commissioning, communication as well as extended functions such as Safety Integrated are sure to provide all the technical knowledge service engineers will need.

All courses contain as many practical exercises as possible to enable intensive and direct training on the drive system and with the tools in small groups.

Please also take note of the training options available for SIMOTICS motors. You will find more information about course contents and dates on the internet.

Title (all courses are available in English and German)	Target group			Duration	Order code
	Planners, decision-makers, sales personnel	Commissioning engineers, configuring engineers	Service personnel, maintenance technicians		
Course Fundamentals and overview					
SINAMICS and SIMOTICS – Basics of drive technology	✓	✓	✓	5 days	DR-GAT
Courses SINAMICS S120					
SINAMICS S120 Designing and Engineering	✓	–	–	5 days	DR-S12-PL
SINAMICS S120 Parameterizing and Commissioning with STARTER	–	✓	–	5 days	DR-S12-PM
SINAMICS S120 Parameterizing and Commissioning in the TIA Portal	–	✓	–	5 days	DR-S12-PMT
SINAMICS S120 Parameterizing Safety Integrated	–	✓	–	4 days	DR-S12-SAF
SINAMICS S120 Parameterizing and Optimization	–	✓	–	5 days	DR-S12-OPT
SINAMICS S120 Diagnostics and Service	–	–	✓	5 days	DR-S12-DG
SINAMICS S120 Diagnostics and Service in the TIA Portal	–	–	✓	5 days	DR-S12-DGT
SINAMICS S120 Diagnostics on Chassis and Cabinet Units	–	✓	✓	3 days	DR-S12-CHA
Course SINAMICS G120 (including SINAMICS G120X, SINAMICS G120D and SINAMICS G115D)					
Parameterizing and Commissioning	–	✓	–	2 days	DR-G12-PM
Courses SINAMICS G130/G150/G180/S150					
SINAMICS G150/G130/S150 - Diagnostics and Service	–	✓	✓	5 days	DR-G15-DG
SINAMICS G180 – Diagnostics and Service	–	–	✓	2.5 days	DR-G18-DG

Overview**SINAMICS G220 training case**

SINAMICS G220 training case

The SINAMICS G220 training case is a convincing demonstration system thanks to its compact design. It is suitable for direct customer presentations as well as for tests in technical departments. It enables the functions of SINAMICS G220 to be demonstrated and tested quickly and easily.

It contains the following components:

- SINAMICS G220 frequency converter, PROFINET, EtherNet/IP, Modbus TCP/IP, 230 V, 0.55 kW
- SIMATIC S7-1511F PN PLC
- Asynchronous motor, IE3, 0.12 kW
- SINAMICS Smart Adapter (Wi-Fi adapter)
- SINAMICS OM-DQ Option Module DRIVE-CLiQ
- SINAMICS OM-IIoT Option Module IIoT (Edge and cloud interface option module)
- SINAMICS OM-SMT Option Module Safe Motor Temperature (ATEX safe)
- Internal galvanic isolation module

The SINAMICS G220 training case is supplied as a trolley with a removable hood.

Selection and ordering data

Description	Article No.
SINAMICS G220 training case ¹⁾	6AG1067-1AA36-0AA0
Accessories	
SINAMICS G220 synchronous reluctance motor case ¹⁾	6AG1067-1AA41-0AA0

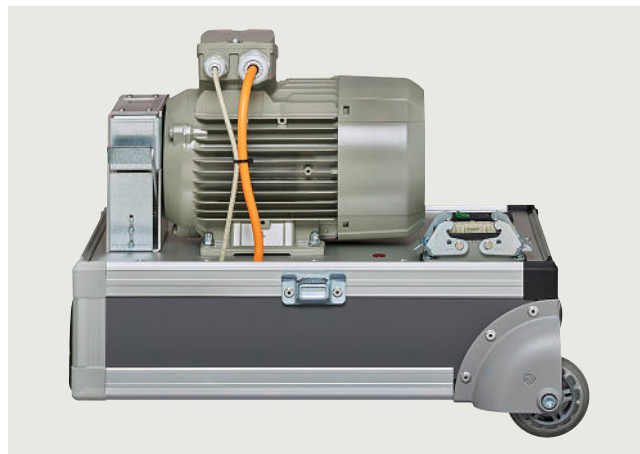
Accessories**SINAMICS G220 synchronous reluctance motor case**

SINAMICS G220 synchronous reluctance motor case

The case serves as a supplement to the SINAMICS G220 training case for applications of synchronous reluctance motors. Together, both cases are used for training and acquisition of the SINAMICS G220 vector control drive system. They are also suitable for use in laboratory testing.

It contains the following components:

- Synchronous reluctance motor, 0.55 kW
- Internal galvanic isolation module

The SINAMICS G220 synchronous reluctance motor case is supplied as a trolley with a removable hood.

Technical specifications

	SINAMICS G220 training case	SINAMICS G220 synchronous reluctance motor case
	6AG1067-1AA36-0AA0	6AG1067-1AA41-0AA0
Supply voltage	230 V 1 AC	230 V 1 AC
Dimensions		
• Width	570 mm (22.46 in)	380 mm (14.97 in)
• Height	320 mm (12.61 in)	430 mm (16.94 in)
• Depth	350 mm (13.79 in)	300 mm (11.82 in)
Weight, approx.	16.2 kg (35.7 lb)	22 kg (48.5 lb)

¹⁾ Available soon.

Services and documentation

Control cabinets

Overview

Complete equipment for machine tools and production systems

Our supplied range of products and services also includes complete equipment for machine tools and production systems with all services in the process chain from consulting through to after-sales service.

We support you in the areas of engineering, production and logistics.

Engineering support

Siemens supports you with advice on design in accordance with standards and concepts for drive systems, control, operation and safety.

Our engineers configure for you in EPLAN P8 and other commonly used CAD systems, execute projects designed to cost and adapt your documents where necessary to UL or new systems.

Our Technical Competence Center Cabinets in Chemnitz supports you with selecting and optimizing the suitable control cabinet air-conditioning system. Apart from calculation and simulation, we also use instrumentation testing in our heat laboratory with load simulation.

We also offer the following services:

- Vibration measurements and control cabinet certification in the field
- Measurement of conducted interference voltages in our laboratory



Cabinet engineering

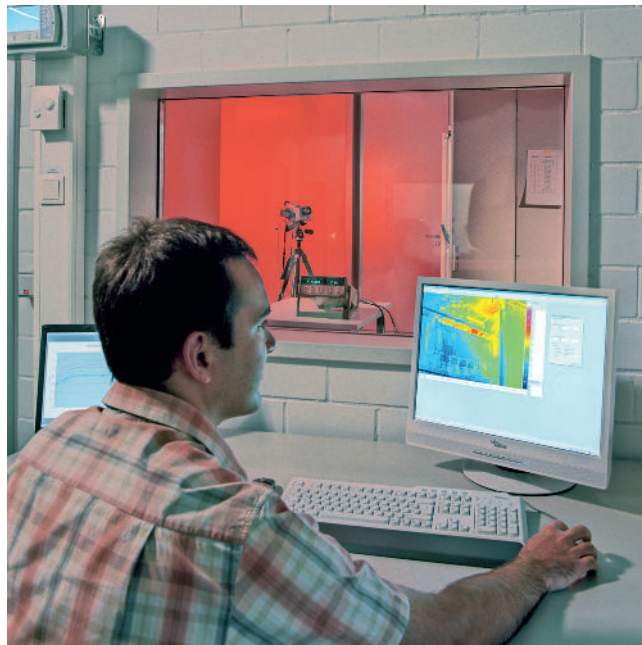

Testing in the heat laboratory

Production at a high level of quality

Complete equipment is manufactured at a high industrial level. This means:

- Examining consistency of the order documentation
- Checking for adherence to current regulations
- Collision check in 3D layout, taking into account the free space required thermally and electrically
- Automatic preparation of enclosures, cables and cable bundles
- Automated inspection and shipment free of faults
- Documentation and traceability
- Declaration of conformity regarding the Low-Voltage Directive and manufacturer's declaration on machinery directive
- UL label on request

Superior logistics

Everything from a single source offers you the following advantages:

- Cost savings for procurement, stockkeeping, financing
- Reduction in throughput times
- Just-in-time delivery

Individual support and maximum flexibility

Our technical consultants for complete equipment support customers and sales departments in the various regions. Our control cabinet customers are supported in the Systems Engineering Plant Chemnitz (WKC) by ordering centers and production teams that are permanently assigned to customers.

Distance does not present a problem; we also use web cams for consulting our customers.

Overview



Worldwide repair service

Customer-specific logistics models, flexible production capacity and production areas as well as change management in all process phases ensure maximum flexibility.

Customized supplementary products

As part of its complete equipment program, Siemens also offers the development and construction of customized supplementary products, e.g. special operator panels and power supply systems.

Liability for defects

Of course we accept the same liability for defects for our complete equipment as for our SINUMERIK and SINAMICS products.

Furthermore, you can use our worldwide repair service anywhere and at any time.

Your benefits

One partner, one quotation, one order, one delivery, one invoice, and one contact partner for liability of defects.

For series production or individual items, Siemens is your competent partner for complete equipment.



Control cabinet with SINAMICS S120 in bookshelf format

Services and documentation

Applications

Overview



Our understanding of an application is the customer-specific solution of an automation task based on standard hardware and software components. In this respect, industry knowledge and technological expertise are just as important as expert knowledge about how our products and systems work. We are setting ourselves this challenge with more than 280 application engineers in 20 countries.

Application centers

We currently have application centers in:

- Germany:
 - Head Office in Erlangen and in other German regions, e.g. in Munich, Nuremberg, Stuttgart, Mannheim, Frankfurt, Chemnitz, Cologne, Bielefeld, Bremen, Hanover, Hamburg
- Belgium: Brussels
- Brazil: Sao Paulo
- China: Beijing and 12 regions
- Denmark: Ballerup
- France: Paris
- Great Britain: Manchester
- India: Mumbai
- Italy: Bologna, Milan
- Japan: Tokyo, Osaka
- The Netherlands: The Hague
- Austria: Vienna
- Poland: Warsaw
- Sweden: Göteborg
- Switzerland: Zurich, Lausanne
- Spain: Madrid
- South Korea: Seoul
- Taiwan: Taipei
- Turkey: Istanbul
- USA: Atlanta

These application centers specialize in the use of SIMATIC/SIMOTION/SINAMICS. You therefore can rely on automation and drive specialists for implementing successful applications. By involving your personnel at an early stage in the process, we can provide a solid basis for rapid knowledge transfer, maintenance and further development of your automation solution.

Advice on applications and implementation

We offer a variety of consultation services to help you find the optimum solution for the SIMATIC/SIMOTION/SINAMICS application you want to implement:

The quotation phase includes

- clarification of technical questions,
- discussion of machine concepts and customer-specific solutions,
- selection of suitable technology and
- suggestions for implementation.

A technical feasibility study is also performed at the outset. In this way, difficult points of the application can be identified and solved early on. We can also configure and implement your application as a complete solution from a single source.

A large number of proven standard applications are available for use during the implementation phase. This saves engineering costs.

The system can be commissioned by experienced, competent personnel, if required. This saves time and trouble.

If servicing is required, we can support you on site or remotely. For further information about servicing, please see the section "Industry Services".

On-site application training

Training for the implemented applications can also be organized and carried out on site. This training for machine manufacturers and their customers does not deal with individual products, but the entire hardware and software system (for example, automation, drives and visualization).

From an initial concept to successful installation and commissioning: We provide complete support for SIMATIC/SIMOTION/SINAMICS! Contact your Siemens representative.

You can find further information at www.siemens.com/machinebuilding

Overview

Efficient and cost-effective maintenance strategies for the entire product lifecycle



For you as an industry plant operator, maximum system productivity is your top priority.

Regular machine and plant maintenance performed by qualified service experts helps you ensure top plant performance for the long term.

For more information visit us at:
www.siemens.com/field-maintenance-services

General overhaul

Overview

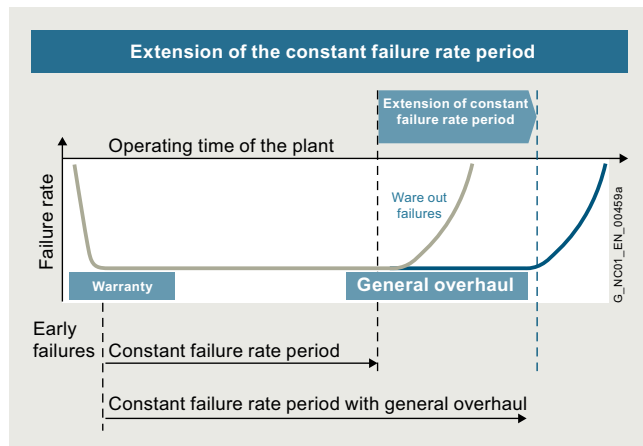

Extension of phases with a constant failure rate

Machines and plants are expected to have a long service life. The service life of electronic components and mechanical parts is, however, limited and normally shorter than the planned machine/plant operating times. For higher availability of the machines or plants, we offer a general overhaul (preventive maintenance) for electronic components and motors at favorable conditions.

During the planned general overhaul, wear parts and aging parts are replaced in accordance with their stated service life so as to reduce unplanned downtimes. In the case of motors, replacement of bearings and encoders is also offered in addition to a general overhaul.

If a fault is detected during a general overhaul, troubleshooting and repair will be performed after requesting confirmation.

In the case of severe wear or major damage, we offer an "as new" spare part instead of a general overhaul for reasons of quality.

Benefits

- Preventive replacement of wear parts and aging parts in accordance with their stated service life
- Reduction in unplanned plant stoppages
- Enhanced production reliability
- Extended availability of your machines/plants
- New liability for defects for 12 months for components which have undergone a general overhaul
- Low price

More information

You can find more information on the internet at:
<https://support.industry.siemens.com/cs/sc/2120>

Contact information for your local Siemens office or national company is available on the internet at:
www.siemens.com/automation-contact

Function check

Overview

A check is made to ensure that the components function reliably. The first step involves cleaning the components. After that, all hardware, software and firmware enhancements are implemented that are known to the development, production, suppliers, service and quality management departments. Using a comprehensive test concept of series production, all functions of the software, firmware, ASICs, and complex and less complex function blocks are checked.

If a fault is detected during an overhaul, troubleshooting and repair will be performed after requesting confirmation. In the case of severe wear or major damage, we offer an "as new" spare part.

Benefits

- The component is checked and can be deployed again
- The component contains all the known improvements
- The customer's own spare parts stock is up-to-date
- Low price

More information

You can find more information on the internet at:
<https://support.industry.siemens.com/cs/sc/2122>

Contact information for your local Siemens office or national company is available on the internet at:
www.siemens.com/automation-contact

Services and documentation

Spare parts services

Overview

Be safe in an emergency – always the right spare part at hand



Minimum downtimes and optimum use of staff and equipment are key to long-term success in industry.

But when a failure happens, it can bring the entire plant to a standstill in the worst case. Since even the best components will eventually reach the end of their lifecycle, our Spare Parts Services form the essential basis for smooth operation.

For more information visit us at:
www.siemens.com/spare-parts-services

Delivery of spare parts

Overview

In every sector worldwide, plants and systems are required to operate with ever increasing availability. Not having a specific spare part at the right time can result in considerable costs.

We will provide you with the support you need to prevent a standstill from occurring in the first place: with a worldwide network and optimized logistics chains.

Order type	Logistics service	Remark
Standard	Cost-optimized: Contracted shipping company	Delivery within the normal national delivery times by the contracted shipping company
Plant downtime	Time-optimized: Express, courier, collection	You choose the shortest possible delivery time as it suits you best: <ul style="list-style-type: none"> • Delivery by means of collection or courier service • Delivery by means of express delivery
Emergency service	Special logistics: Courier	Spare parts can be ordered from us 24/7 – even outside normal working hours, as well as on weekends or national holidays. <ul style="list-style-type: none"> • Delivery by means of courier service

Benefits

- New liability for spare part defects
- Long-term spare parts availability
- Optimum system compatibility

More information

You can find more information on the internet at:
<https://support.industry.siemens.com/cs/sc/2112>

Contact information for your local Siemens office or national company is available on the internet at:
www.siemens.com/automation-contact

Overview

With many products, we also offer you the option of an exchange in addition to the simple delivery of spare parts. This has the advantage that you not only receive the spare part quickly, but are able to return the defective device to us for a credit. You therefore receive our spare part at the lower exchange price.

A credit will be awarded on condition that the repair code indicates that repurchasing is admissible, a replacement is obtained from the spare parts store, and that the returned product is repairable.

The order type and logistics service determine the delivery of spare parts:

Order type	Logistics service	Remark
Standard	Cost-optimized: Contracted shipping company	Delivery within the normal national delivery times by the contracted shipping company
Plant downtime	Time-optimized: Express, courier, collection	You choose the shortest possible delivery time as it suits you best: <ul style="list-style-type: none"> • Delivery by means of collection or courier service • Delivery by means of express delivery
Emergency service	Special logistics: Courier	Spare parts can be ordered from us 24/7 – even outside normal working hours, as well as on weekends or national holidays. <ul style="list-style-type: none"> • Delivery by means of courier service

Return

For product returns, we require the following information:

- Reason for return
- If defective: detailed description of the fault
- Machine number
- Machine/system manufacturer
- End user

We will then be able to provide you with additional information in the repair report/inspection report regarding the diagnosis/inspection as well as information about the completed repair.

Benefits

- Price benefits through the option of returning defective parts
- A spare part is available immediately in the event of failure
- New liability for spare part defects
- Long-term spare parts availability
- Optimum system compatibility

More information

You can find more information on the internet at:
<https://support.industry.siemens.com/cs/sc/2112>

Contact information for your local Siemens office or national company is available on the internet at:
www.siemens.com/automation-contact

Overview

Upgrade service for components: From OLD to NEW

Machines and plant are expected to have a long service life. The service life of the electronic components is, however, limited and normally shorter than the planned machine/plant operating times. To ensure that the required extended availability of the machines/plants is achieved, we offer an upgrade service for components at an attractive price.

In the course of their lifecycle, electronic components are normally redesigned/upgraded several times. With the upgrade service for components, you will always receive the latest technology.

A planned component upgrade from OLD to NEW helps to prevent unplanned machine stoppages and supports a safer and longer machines/plant availability. The upgrade service is mainly offered for older components that will soon be discontinued.

For information about the latest potential upgrades, please contact your local contact person. The upgrade service for components can only be offered to machine manufacturers or operators.

Benefits

- Price benefit through upgrade service
- New liability for new component defects
- Extended availability of your machines/plants
- Prevention of component failures due to wear and aging
- Prevention of machine stoppages due to unavailability of spare parts
- Reduced spare parts inventories
- Latest technology
- Easier servicing due to fewer variants
- Industry Services through Siemens are assured for the future

More information

You can find more information on the internet at:
<https://support.industry.siemens.com/cs/sc/2112>

Contact information for your local Siemens office or national company is available on the internet at:
www.siemens.com/automation-contact

Services and documentation

Spare parts services

Return of diagnostic parts

Overview

Spare parts used for diagnostic purposes from the spare parts store can be returned within 3 months and a credit note for up to 85 % is issued.

For unused spare parts in their original packaging, you will receive a credit of 100 % in which case you will be charged a fixed price for handling.

Benefits

- Can be used for diagnostics
- Reduced spare parts inventories
- Low costs

More information

You can find more information on the internet at: <https://support.industry.siemens.com/cs/sc/2112>

Contact information for your local Siemens office or national company is available on the internet at: www.siemens.com/automation-contact

Stock reduction in spare parts store

Overview

Fast spare part delivery by Siemens enables manufacturers and plant operators to reduce their spare part stocks. For this purpose, we offer an analysis that shows exactly which parts should remain in the customer warehouse for a particular machine stock and which can be purchased directly from Siemens.

Benefits

- Reduced costs
- Stock optimization
- Minimization of fault downtimes

More information

You can find more information on the internet at: <https://support.industry.siemens.com/cs/sc/2112>

Contact information for your local Siemens office or national company is available on the internet at: www.siemens.com/automation-contact

Extended spare part availability

Overview

We normally retain spare parts for all products and systems for a period of 10 years after discontinuation of product marketing.

In individual cases, when we do not carry spare parts, we will offer a repair.

For a wide range of products and systems, spare parts availability is extended. We can provide you with the current spare parts availability for your machines/plants as a service once you have registered online with identSNAPSHOT.

www.siemens.com/identsnapshot

If you require longer availability of spare parts for your machines/plants, please contact your local contact person.

Benefits

- Higher plant availability
- Security of investment
- Reduction of lifecycle costs

More information

You can find more information on the internet at: <https://support.industry.siemens.com/cs/sc/2112>

Contact information for your local Siemens office or national company is available on the internet at: www.siemens.com/automation-contact

Overview

High quality support in a breakdown – either at your premises or at a certified Siemens workshop

Even the best components eventually reach the end of their lifecycle. The result: downtimes and reduced productivity.

Our Repair Services comprise all service tasks over the entire product lifecycle, from functional maintenance to increasing performance. In this way, our service experts analyze, repair, maintain and optimize your components at Siemens manufacturer level, so that costly downtimes are minimized.

For more information visit us at:
www.siemens.com/repair-services

Downtimes cause problems in the plant as well as unnecessary costs. We can help you to reduce both to a minimum – with our worldwide repair facilities. The advantages for you are: Defects can be rectified before they cause further harm.

Repair is a favorable option when you have specific reasons for not wanting to replace the defective device or part with a new one (delivery as exchange product).

We maintain a global network of Siemens repair shops and certified partners to ensure that we will always be able to process your repairs quickly.

We can offer you different types of repair depending on your requirements:

Normal repair

Normal repair at standard conditions normally takes 10 working days following receipt of the defective item at our repair shop.

Fast repair

In particularly urgent cases, we offer you the option of a fast repair within 1 or 2 working days for many products at additional cost.

Mobile repair service

We come to you and perform the required repairs on site, for example, when the device or component cannot be removed due to its weight.

Function repair

A function repair is the same as a normal repair but excludes the repair of cosmetic defects, e.g. scratches, inscriptions, discoloration. The conditions applicable to function repairs should be observed in this case. The function repair can only be offered to machine manufacturers or operators. Please contact your local contact person for more information.

Long Life Repair

As a rule, a spare parts and repair service is offered for electronics products for a period of up to ten years after the period of active marketing. After this time, these services are generally only available in the case of acknowledged warranty conditions. Not so at Siemens. The Long Life Repair Service is available for selected electronic products and standard motors. Siemens thus offers a complete solution that includes short delivery times, long availability of original spare parts, economical repairs and a service availability of up to 25 years.

Benefits

- Short downtimes for machines and plants
- Only certified original parts are used
- Additional services from Siemens:
 - Longer availability of your machine/plant through the early replacement of wear parts and aging parts
 - Highest standards of quality
 - Use of the comprehensive test concept of series production, including software, firmware, ASICs, complex function blocks, etc.
 - Implementation of all the hardware and software/firmware enhancements known from development, production, suppliers, and service and quality management departments.
- Information supplied by repair report/inspection report

More information

You can find more information on the internet at:
<https://support.industry.siemens.com/cs/sc/3098>

Contact information for your local Siemens office or national company is available on the internet at:
www.siemens.com/automation-contact

Services and documentation

Spares on Web

Overview

Spares on Web – online identification of spare parts

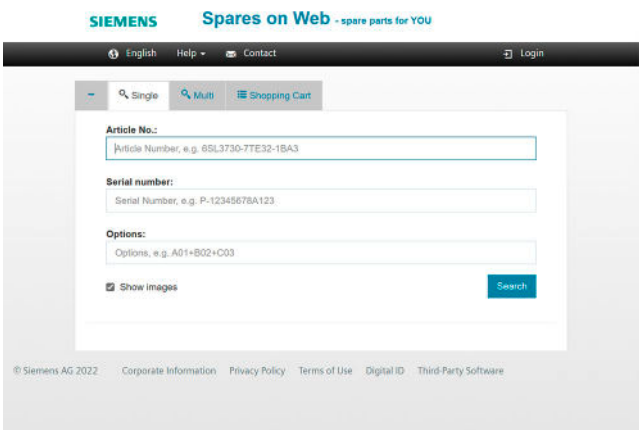

The screenshot displays the Siemens Spares on Web interface. At the top, the Siemens logo and the text "Spares on Web - spare parts for YOU" are visible. Below this, there is a navigation bar with "English", "Help", "Contact", and "Login" links. The main search area includes a "Single" search mode selected, a "Multi" search mode, and a "Shopping Cart" icon. The search form contains three input fields: "Article No." with a placeholder "Article Number, e.g. 6SL3730-7TE32-1BA3", "Serial number" with a placeholder "Serial Number, e.g. P-12345678A123", and "Options" with a placeholder "Options, e.g. A01+B02+C03". A "Search" button is located to the right of the "Options" field. Below the search form, there is a "Show Images" checkbox. At the bottom of the page, there is a footer with the text "© Siemens AG 2022" and links for "Corporate Information", "Privacy Policy", "Terms of Use", "Digital ID", and "Third-Party Software".

Spares on Web is a web-based tool for identifying spare parts. After you have entered the Article No. and serial number, the spare parts available for the relevant unit are displayed.

www.siemens.com/sow

Overview

Siemens Product Partners for Drives Options

Individual options for our drives

In order to meet as many customer requirements as possible in the field of drive technology, in addition to its own products, Siemens also relies on the individual and complementary services of selected partners.

We are increasingly focusing on the standard drive options, and our Siemens Product Partners for Drives Options supplement our drives with individual drive options.

This gives Siemens a unique flexibility to meet all application requirements. Naturally, we support our Siemens Product Partners for Drives Options in tailoring their options perfectly to our drives.

For you as our customer, there are multiple benefits:

- The Siemens Product Partners for Drives Options meet the same high standards of quality and performance that we place on our own products
- Drive options can be adapted to individual requirements/designs
- The Siemens Product Partners for Drives Options know our Siemens converter portfolio and can advise you individually and quickly

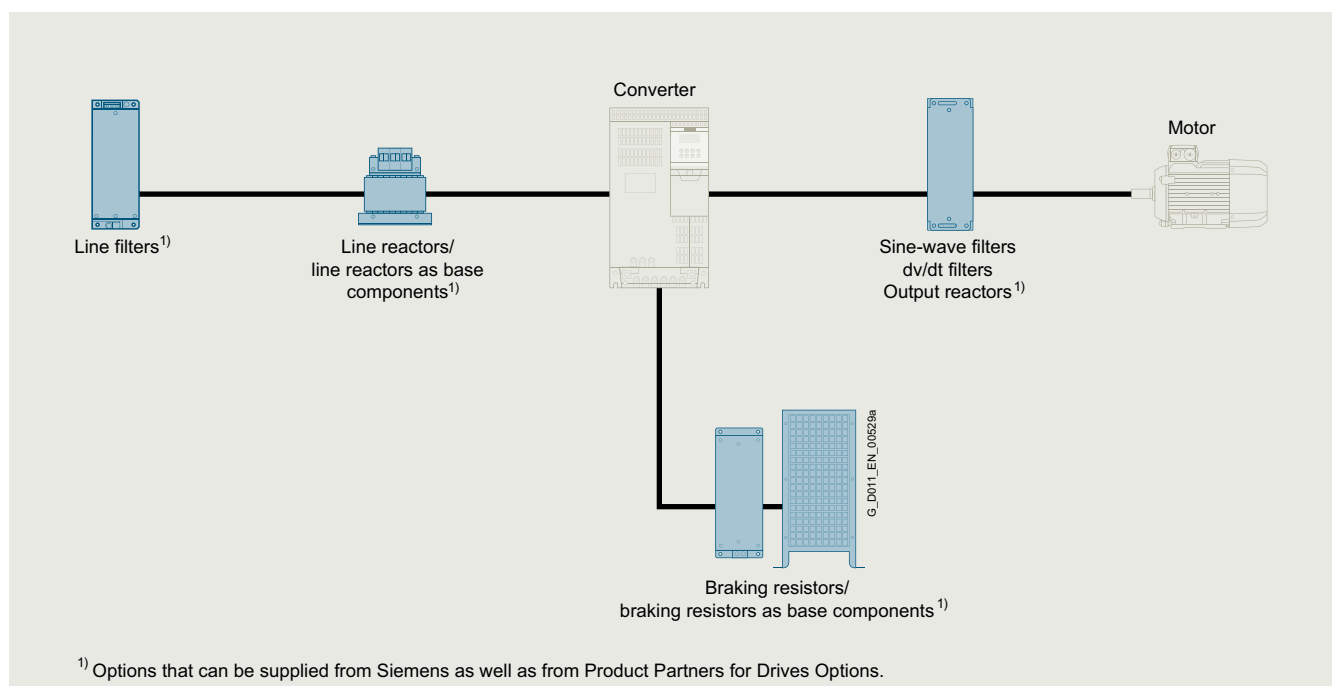

Schematic circuit diagram

More information

You can find more information on the internet at www.siemens.com/drives-options-partner

Services and documentation

mySupport documentation

Overview

mySupport documentation – Compiling personal documents

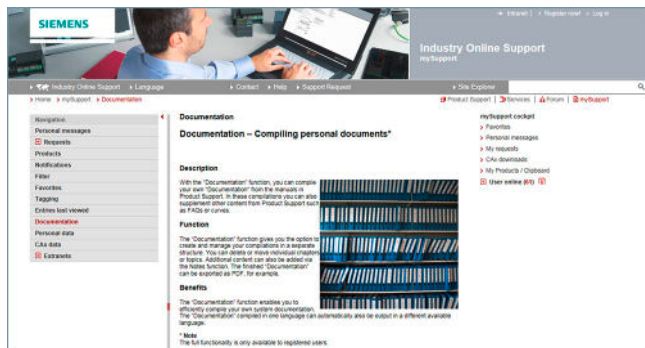

mySupport documentation is a web-based system for generating personalized documentation based on standard documents and is part of the Siemens Industry Online Support portal.

In mySupport, a personal document library can be created in the "Documentation" category. This library can be accessed online in mySupport or also be generated in various formats for offline use.

Previously, this functionality was available in the My Documentation Manager for configurable manuals. Due to the integration in mySupport, all entries of the Industry Online Support can now be imported into the personal document library, including FAQs or product notifications.

If you have already worked with the My Documentation Manager, all of the previously created libraries will continue to be available without restrictions in mySupport.

In addition, the personal library in mySupport can be shared with other mySupport users. In this way, a collection of relevant documents can be created very effectively and used together with other mySupport users all over the world.

You must register/log in for configuring and generating/managing.

Benefits

- Display
View, print or download standard documents or personalized documents
- Configure
Transfer standard documents or parts of them to personalized documents
- Generate/Manage
Generate and manage personalized documents in the formats PDF, RTF or XML in all available languages

Function

Opening mySupport documentation in the Industry Online Support portal

- About the product support, entry type "Manual":
<https://support.industry.siemens.com/cs/ww/en/ps/man>
By clicking on the required version of the manual and then "Show and configure", the manual opens in a modular view, where you can navigate from topic to topic. Here the direct link to a topic can be used and made available to other users. The selected document can be added to the personal library via "mySupport Cockpit" > "Add to mySupport documentation".
- Via the direct link
<https://support.industry.siemens.com/my/ww/en/documentation/advanced>
After logon/registration, the online help is displayed as the current document.

More information

You can find additional information on the internet at

- <https://support.industry.siemens.com/my/ww/en/documentation>
- https://support.industry.siemens.com/cs/helpcenter/en/index.htm?#persoenliche_bibliothek_aufbauen.htm

Overview

A high-quality programmable control or drive system can be used to maximum effect only if the user is aware of the performance of the products used as a result of intensive training and good technical documentation.

This is becoming more important due to the shorter innovation cycles of modern automation products and the convergence of electronics and mechanical engineering.

A comprehensive range of documentation is available which includes a Getting Started guide, operating instructions, installation manuals and a list manual.

In addition to technical information for SINUMERIK, SINAMICS, SIMOTION and SIMOTICS, the documentation is available for downloading as a PDF file from the internet:

- SINUMERIK
<https://support.industry.siemens.com/cs/document/108464614>
- SINAMICS
<https://support.industry.siemens.com/cs/document/109807358>
- SIMOTION
<https://support.industry.siemens.com/cs/document/109479653>
- SIMOTICS
<https://support.industry.siemens.com/cs/document/109813641>

Selection and ordering data

Description	Article No.
Automating with PROFINET: Industrial Communication Based on Industrial Ethernet	Via bookstore
<ul style="list-style-type: none"> • German • English 	ISBN 978-3-89578-293-0 ISBN 978-3-89578-294-7

Application

Explanations of the manuals:

- **Operating Instructions**
contain all the information needed to install the device and make electrical connections, information about commissioning and a description of the converter functions.
Phases of use: Control cabinet construction, commissioning, operation, maintenance and servicing.
- **Hardware Installation Manual**
contains all relevant information about the intended use of the components of a system (technical specifications, interfaces, dimensional drawings, characteristics, or possible applications), information about installation and electrical connections and information about maintenance and servicing.
Phases of use: Control cabinet configuration/construction, maintenance and servicing.
- **Operating and Installation Instructions (for converter and accessories)**
contain all relevant information about the intended use of the components, such as technical specifications, interfaces, dimensional drawings, characteristics, or possible applications.
Phases of use: Control cabinet configuration/construction.
- **Manual/Configuration Manual**
contains all necessary information about the intended use of the components of a system, e.g. technical specifications, interfaces, dimensional drawings, characteristics, or possible applications.
Phases of use: Cabinet configuration/setup, circuit diagram configuration/drawing.
- **Commissioning Manual**
contains all information relevant to commissioning after installation and wiring. It also contains all safety and warning notices relevant to commissioning in addition to overview drawings.
Phases of use: Commissioning of components that have already been connected, configuration of system functions.
- **List Manual**
contains all parameters, function diagrams, and faults/alarms for the product/system as well as their meanings and setting options. It contains parameter data and fault/alarm descriptions with functional correlations.
Phases of use: Commissioning of components that have already been connected, configuration of system functions, fault cause/diagnosis.
- **Getting Started**
provides information about getting started for the first-time user as well as references to additional information. It contains information about the basic steps to be taken during commissioning. The information in the other documentation should be carefully observed for all of the other work required.
Phases of use: Commissioning of components that have already been connected.
- **Function Manual Drive Functions**
contains all the relevant information about individual drive functions: Description, commissioning and integration in the drive system.
Phases of use: Commissioning of components that have already been connected, configuration of system functions.

Services and documentation

Documentation

SINAMICS G220 documentation

Overview

Identification link according to IEC 61406 for SINAMICS G220

The ID link contains the article and serial number of the product. As a QR code, it replaces the previous data matrix code on the nameplate and takes you with the URL directly to a product information page on the internet with access to the technical documentation, data sheet, certificates, FAQs, product notifications, and catalogs. Paper package inserts become superfluous since the information is available electronically directly via the QR code, even years later. In this way, we are making a valuable contribution to the preservation of our environment. You don't need an additional app. Simply scan the QR code with your smartphone or tablet. According to IEC 61406, the QR code of an ID link is marked with a frame and a triangle at the bottom right.

With their globally unique identifiers, Siemens products are ready for Industry 4.0.

The ID serves as a connection to the administration shell with which modules of the digital twin can be provided.

Further documentation, such as the operating instructions, is available free on the internet at:

www.siemens.com/sinamics-g220/documentation

Detailed information on the SINAMICS G220 built-in and wall-mounted units, including the latest technical documentation (brochures, tutorials, dimensional drawings, certificates and operating instructions), is available on the internet at:

www.siemens.com/sinamics-g220

and is also available via the Siemens Product Configurator on the internet.

The Siemens Product Configurator can be found in the Siemens Industry Mall at the following address:

www.siemens.com/spc

Environmental Product Declaration (EPD)

Environmental Product Declarations (EPD) are available as PDFs for this product.

The EPD PDF provides brief and concise information about the ecological properties of a product.

You can find more information on the internet at:
<https://support.industry.siemens.com/cs/ww/en/ps/28308/cert?ci=5690>

Appendix



5/2 Certificates of suitability (approvals)

5/4 Software licenses

5/6 Conversion tables

5/9 Conditions of sale and delivery

Appendix

Certificates of suitability (approvals)







Overview

Many of the products in this catalog fulfill requirements, e.g. for UL, CSA or FM and are labeled with the corresponding approval designation.

All of the certificates of suitability, approvals, certificates, declarations of conformity, test certificates, e.g. CE, UL, Safety Integrated etc. have been performed with the associated system components as they are described in the Catalogs and Configuration Manuals.



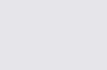

The certificates are only valid if the products are used with the described system components, are installed according to the Installation Guidelines and used for their intended purpose.

In other cases, the vendor of these products is responsible for arranging for the issue of new certificates.

Test code	Tested by	Device series/ Component	Test standard	Product category/ File No.
UL: Underwriters Laboratories Independent public testing body in North America				
	UL according to UL standard	SINUMERIK	Standard UL 508, CSA C22.2 No. 142	NRAQ/7.E164110 NRAQ/7.E217227
		SIMOTION	Standard UL 508, CSA C22.2 No. 142	NRAQ/7.E164110
	UL according to CSA standard	SINAMICS	Standard UL 508, 508C, 61800-5-1 CSA C22.2 No. 142, 274	NRAQ/7.E164110, NMMS/2/7/8.E192450, NMMS/2/7/8.E203250, NMMS/7.E214113, NMMS/7.E253831
				NMMS/2/7/8.E121068 NMMS/7.E355661 NMMS/7.E323473
	UL according to UL and CSA standards			
	UL according to UL standard	SIMODRIVE	Standard UL 508C, CSA C22.2 No. 274	NMMS/2/7/8.E192450 NMMS/7.E214113
	UL according to CSA standard	SIMOTICS	Standard UL 1004-1, 1004-6, 1004-8, CSA C22.2 No. 100	PRGY2/8.E227215 PRHZ2/8.E93429 PRHJ2/8.E342747
				PRGY2/8.E253922 PRHZ2/8.E342746
	UL according to UL and CSA standards			
		Line/motor reactors	Standard UL 508, 506, 5085-1, 5085-2, 1561, CSA C22.2 No. 14, 47, 66.1-06, 66.2-06	XQNX2/8.E257859 NMTR2/8.E219022 NMMS2/8.E333628 XPTQ2/8.E257852 XPTQ2/8.E103521 NMMS2/8.E224872 XPTQ2/8.E354316 XPTQ2/8.E198309 XQNX2/8.E475972
		Line filters, dv/dt filters, sine-wave filters	UL 1283, CSA C22.2 No. 8	FOKY2/8.E70122
		Resistors	UL 508, 508C, CSA C22.2 No. 14, 274	NMTR2/8.E224314 NMMS2/8.E192450 NMTR2/8.E221095 NMTR2/8.E226619
TUV: TÜV Rheinland of North America Inc. Independent public testing body in North America, Nationally Recognized Testing Laboratory (NRTL)				
TÜV: TÜV SÜD Product Service Independent public testing body in Germany, Nationally Recognized Testing Laboratory (NRTL) for North America				
	TUV according to UL and CSA standards	SINAMICS	NRTL listing according to standard UL 508C	U7V 12 06 20078 013 U7 11 04 20078 009 U7 11 04 20078 010 U7 11 04 20078 011
		SIMOTION	NRTL listing according to standard UL 508	U7V 13 03 20078 01
		SIMODRIVE	NRTL listing according to standard UL 508C, CSA C22.2. No. 14	CU 72090702
		Motion Control Encoder	NRTL listing according to UL 61010-1 CSA C22.2 No. 61010-1	U8V 10 06 20196 024

Certificates of suitability (approvals)

Overview

Test code	Tested by	Device series/ Component	Test standard	Product category/ File No.
CSA: Canadian Standards Association Independent public testing body in Canada				
	CSA according to CSA standard	SINUMERIK	Standard CSA C22.2 No. 142	2252-01 : LR 102527
FMRC: Factory Mutual Research Corporation Independent public testing body in North America				
	FM according to FM standard	SINUMERIK	Standard FMRC 3600, FMRC 3611, FMRC 3810, ANSI/ISA S82.02.1	–
EAC: Independent public testing body within the Eurasian Conformity Area				
	EAC in accordance with the EAC Directive	SINAMICS SINUMERIK SIMOTION	Standard IEC 61800-5-1/-2, IEC 61800-3	–
RCM: Australian Communications and Media Authority Independent public testing body in Australia				
	RCM according to EMC standard	SINAMICS SINUMERIK SIMOTION	Standard IEC AS 61800-3, EN 61800-3	–
KC: National Radio Research Agency Independent public testing body in South Korea				
	KC according to EMC standard	SINAMICS SINUMERIK SIMOTION	Standard KN 11	–
BIA Federal Institute for Occupational Safety				
–	Functional safety	SINAMICS SINUMERIK SIMOTION	Standard EN 61800-5-2	–
TÜV SÜD Rail				
–	Functional safety	SINAMICS SINUMERIK SIMOTION	Standard EN 61800-5-2	–

More information about certificates can be found online at:
<https://support.industry.siemens.com/cs/ww/en/ps/cert>

Appendix

Software licenses

Overview

Software types

Software requiring a license is categorized into types. The following software types have been defined:

- Engineering software
- Runtime software

Engineering software

This includes all software products for creating (engineering) user software, e.g. for configuring, programming, parameterizing, testing, commissioning or servicing.

Data generated with engineering software and executable programs can be duplicated for your own use or for use by third-parties free-of-charge.

Runtime software

This includes all software products required for plant/machine operation, e.g. operating system, basic system, system expansions, drivers, etc.

The duplication of the runtime software and executable programs created with the runtime software for your own use or for use by third-parties is subject to a charge.

You can find information about license fees according to use in the ordering data (e.g. in the catalog). Examples of categories of use include per CPU, per installation, per channel, per instance, per axis, per control loop, per variable, etc.

Information about extended rights of use for parameterization/configuration tools supplied as integral components of the scope of supply can be found in the readme file supplied with the relevant product(s).

License types

Siemens Digital Industries and Smart Infrastructure offers various types of software license:

- Floating license
- Single license
- Rental license
- Rental floating license
- Trial license
- Demo license
- Demo floating license

Floating license

The software may be installed for internal use on any number of devices by the licensee. Only the concurrent user is licensed. The concurrent user is the person using the program. Use begins when the software is started. A license is required for each concurrent user.

Single license

Unlike the floating license, a single license permits only one installation of the software per license.

The type of use licensed is specified in the ordering data and in the Certificate of License (CoL). Types of use include for example per instance, per axis, per channel, etc.

One single license is required for each type of use defined.

Rental license

A rental license supports the "sporadic use" of engineering software. Once the license key has been installed, the software can be used for a specific period of time (the operating hours do not have to be consecutive).

One license is required for each installation of the software.

Rental floating license

The rental floating license corresponds to the rental license, except that a license is not required for each installation of the software. Rather, one license is required per object (for example, user or device).

Trial license

A trial license supports "short-term use" of the software in a non-productive context, e.g. for testing and evaluation purposes. It can be transferred to another license.

Demo license

The demo license support the "sporadic use" of engineering software in a non-productive context, for example, use for testing and evaluation purposes. It can be transferred to another license. After the installation of the license key, the software can be operated for a specific period of time, whereby usage can be interrupted as often as required.

One license is required per installation of the software.

Demo floating license

The demo floating license corresponds to the demo license, except that a license is not required for each installation of the software. Rather, one license is required per object (for example, user or device).

Certificate of License (CoL)

The CoL is the licensee's proof that the use of the software has been licensed by Siemens. A CoL is required for every type of use and must be kept in a safe place.

Downgrading

The licensee is permitted to use the software or an earlier version/release of the software, provided that the licensee owns such a version/release and its use is technically feasible.

Delivery versions

Software is constantly being updated. The following delivery versions

- PowerPack
- Upgrade

can be used to access updates.

Existing bug fixes are supplied with the ServicePack version.

PowerPack

PowerPacks can be used to upgrade to more powerful software. The licensee receives a new license agreement and CoL (Certificate of License) with the PowerPack. This CoL, together with the CoL for the original product, proves that the new software is licensed.

A separate PowerPack must be purchased for each original license of the software to be replaced.

Upgrade

An upgrade permits the use of a new version of the software on the condition that a license for a previous version of the product is already held.

The licensee receives a new license agreement and CoL with the upgrade. This CoL, together with the CoL for the previous product, proves that the new version is licensed.

A separate upgrade must be purchased for each original license of the software to be upgraded.

Overview

ServicePack

ServicePacks are used to debug existing products. ServicePacks may be duplicated for use as prescribed according to the number of existing original licenses.

License key

Siemens Digital Industries and Smart Infrastructure supplies software products with and without license keys.

The license key serves as an electronic license stamp and is also the "switch" for activating the software (floating license, rental license, etc.).

The complete installation of software products requiring license keys includes the program to be licensed (the software) and the license key (which represents the license).

Software Update Service (SUS)

As part of the SUS contract, all software updates for the respective product are made available to you free of charge for a period of one year from the invoice date. The contract will automatically be extended for one year if it is not canceled three months before it expires.

The possession of the current version of the respective software is a basic condition for entering into an SUS contract.

You can download explanations concerning license conditions from https://mall.industry.siemens.com/legal/ww/en/terms_of_trade_en.pdf

Appendix

Conversion tables

Rotary inertia (to convert from A to B, multiply by entry in table)

A \ B	lb-in ²	lb-ft ²	lb-in-s ²	lb-ft-s ² slug-ft ²	kg-cm ²	kg-cm-s ²	gm-cm ²	gm-cm-s ²	oz-in ²	oz-in-s ²
lb-in ²	1	6.94×10^{-3}	2.59×10^{-3}	2.15×10^{-4}	2.926	2.98×10^{-3}	2.92×10^3	2.984	16	4.14×10^{-2}
lb-ft ²	144	1	0.3729	3.10×10^{-2}	421.40	0.4297	4.21×10^5	429.71	2304	5.967
lb-in-s ²	386.08	2.681	1	8.33×10^{-2}	1.129×10^3	1.152	1.129×10^6	1.152×10^3	6.177×10^3	16
lb-ft-s ² slug-ft ²	4.63×10^3	32.17	12	1	1.35×10^4	13.825	1.355×10^7	1.38×10^4	7.41×10^4	192
kg-cm ²	0.3417	2.37×10^{-3}	8.85×10^{-4}	7.37×10^{-5}	1	1.019×10^{-3}	1000	1.019	5.46	1.41×10^{-2}
kg-cm-s ²	335.1	2.327	0.8679	7.23×10^{-2}	980.66	1	9.8×10^5	1000	5.36×10^3	13.887
gm-cm ²	3.417×10^{-4}	2.37×10^{-6}	8.85×10^{-7}	7.37×10^{-8}	1×10^{-3}	1.01×10^{-6}	1	1.01×10^{-3}	5.46×10^{-3}	1.41×10^{-5}
gm-cm-s ²	0.335	2.32×10^{-3}	8.67×10^{-4}	7.23×10^{-5}	0.9806	1×10^{-3}	980.6	1	5.36	1.38×10^{-2}
oz-in ²	0.0625	4.34×10^{-4}	1.61×10^{-4}	1.34×10^{-5}	0.182	1.86×10^{-4}	182.9	0.186	1	2.59×10^{-3}
oz-in-s ²	24.13	0.1675	6.25×10^{-2}	5.20×10^{-3}	70.615	7.20×10^{-2}	7.09×10^4	72.0	386.08	1

Torque (to convert from A to B, multiply by entry in table)

A \ B	lb-in	lb-ft	oz-in	N-m	kg-cm	kg-m	gm-cm	dyne-cm
lb-in	1	8.333×10^{-2}	16	0.113	1.152	1.152×10^{-2}	1.152×10^3	1.129×10^6
lb-ft	12	1	192	1.355	13.825	0.138	1.382×10^4	1.355×10^7
oz-in	6.25×10^{-2}	5.208×10^{-3}	1	7.061×10^{-3}	7.200×10^{-2}	7.200×10^{-4}	72.007	7.061×10^4
N-m	8.850	0.737	141.612	1	10.197	0.102	1.019×10^4	1×10^7
kg-cm	0.8679	7.233×10^{-2}	13.877	9.806×10^{-2}	1	10^{-2}	1000	9.806×10^5
kg-m	86.796	7.233	1.388×10^3	9.806	100	1	1×10^5	9.806×10^7
gm-cm	8.679×10^{-4}	7.233×10^{-5}	1.388×10^{-2}	9.806×10^{-5}	1×10^{-3}	1×10^{-5}	1	980.665
dyne-cm	8.850×10^{-7}	7.375×10^{-8}	1.416×10^{-5}	10^{-7}	1.0197×10^{-6}	1.019×10^{-8}	1.019×10^{-3}	1

Length (to convert from A to B, multiply by entry in table)

A \ B	inches	feet	cm	yd	mm	m
inches	1	0.0833	2.54	0.028	25.4	0.0254
feet	12	1	30.48	0.333	304.8	0.3048
cm	0.3937	0.03281	1	1.09×10^{-2}	10	0.01
yd	36	3	91.44	1	914.4	0.914
mm	0.03937	0.00328	0.1	1.09×10^{-3}	1	0.001
m	39.37	3.281	100	1.09	1000	1

Force (to convert from A to B, multiply by entry in table)

A \ B	lb	oz	gm	dyne	N
lb	1	16	453.6	4.448×10^5	4.4482
oz	0.0625	1	28.35	2.780×10^4	0.27801
gm	2.205×10^{-3}	0.03527	1	1.02×10^{-3}	N.A.
dyne	2.248×10^{-6}	3.59×10^{-5}	980.7	1	0.00001
N	0.22481	3.5967	N.A.	100000	1

Mass (to convert from A to B, multiply by entry in table)

A \ B	lb	oz	gm	kg	slug
lb	1	16	453.6	0.4536	0.0311
oz	6.25×10^{-2}	1	28.35	0.02835	1.93×10^{-3}
gm	2.205×10^{-3}	3.527×10^{-2}	1	10^{-3}	6.852×10^{-5}
kg	2.205	35.27	10^3	1	6.852×10^{-2}
slug	32.17	514.8	1.459×10^4	14.59	1

Rotation (to convert from A to B, multiply by entry in table)

A \ B	r/min	rad/s	degrees/s
r/min	1	0.105	6.0
rad/s	9.55	1	57.30
degrees/s	0.167	1.745×10^{-2}	1

Power (to convert from A to B, multiply by entry in table)

A \ B	hp	Watts
hp (English)	1	745.7
(lb-in) (deg./s)	2.645×10^{-6}	1.972×10^{-3}
(lb-in) (r/min)	1.587×10^{-5}	1.183×10^{-2}
(lb-ft) (deg./s)	3.173×10^{-5}	2.366×10^{-2}
(lb-ft) (r/min)	1.904×10^{-4}	0.1420
Watts	1.341×10^{-3}	1

Temperature Conversion

°F	°C	°C	°F
0	-17.8	-10	14
32	0	0	32
50	10	10	50
70	21.1	20	68
90	32.2	30	86
98.4	37	37	98.4
212	100	100	212
subtract 32 and multiply by $\frac{5}{9}$		multiply by $\frac{9}{5}$ and add 32	

Mechanism Efficiencies

Acme-screw with brass nut	~0.35–0.65
Acme-screw with plastic nut	~0.50–0.85
Ball-screw	~0.85–0.95
Chain and sprocket	~0.95–0.98
Preloaded ball-screw	~0.75–0.85
Spur or bevel-gears	~0.90
Timing belts	~0.96–0.98
Worm gears	~0.45–0.85
Helical gear (1 reduction)	~0.92

Friction Coefficients

Materials	μ
Steel on steel (greased)	~0.15
Plastic on steel	~0.15–0.25
Copper on steel	~0.30
Brass on steel	~0.35
Aluminum on steel	~0.45
Steel on steel	~0.58
Mechanism	μ
Ball bushings	<0.001
Linear bearings	<0.001
Dove-tail slides	~0.2++
Gibb ways	~0.5++

Material Densities

Material	lb-in ³	gm-cm ³
Aluminum	0.096	2.66
Brass	0.299	8.30
Bronze	0.295	8.17
Copper	0.322	8.91
Hard wood	0.029	0.80
Soft wood	0.018	0.48
Plastic	0.040	1.11
Glass	0.079–0.090	2.2–2.5
Titanium	0.163	4.51
Paper	0.025–0.043	0.7–1.2
Polyvinyl chloride	0.047–0.050	1.3–1.4
Rubber	0.033–0.036	0.92–0.99
Silicone rubber, without filler	0.043	1.2
Cast iron, gray	0.274	7.6
Steel	0.280	7.75

Wire Gauges¹⁾

Cross-section mm ²	Standard Wire Gauge (SWG)	American Wire Gauge (AWG)
0.2	25	24
0.3	23	22
0.5	21	20
0.75	20	19
1.0	19	18
1.5	17	16
2.5	15	13
4	13	11
6	12	9
10	9	7
16	7	6
25	5	3
35	3	2
50	0	1/0
70	000	2/0
95	00000	3/0
120	0000000	4/0
150	–	6/0
185	–	7/0

¹⁾ The table shows approximate SWG/AWG sizes nearest to standard metric sizes; the cross-sections do not match exactly.

Appendix

Notes

1. General Provisions

By using this catalog you can purchase hard- and software products as well as services (together hereinafter referred to as "products") described therein from Siemens Aktiengesellschaft subject to the following Terms and Conditions of Sale and Delivery (hereinafter referred to as "T&C"). Note, for products purchased from any Siemens entity having a registered office outside of Germany, the respective terms and conditions of sale and delivery of the respective Siemens entity apply exclusively. The following T&C apply exclusively for orders placed with Siemens Aktiengesellschaft, Germany.

1.1 For customers with a seat or registered office in European Union

For customers with a seat or registered office in European Union, the following terms and conditions apply subordinate to T&C:

- for products, which include specific terms and conditions in the text of the product description, these specific terms and conditions shall apply and subordinate thereto,,
- for stand-alone software products and software products forming a part of a product or project, the "General Conditions for Software Products for Infrastructure & Industry Business (German law)"¹⁾ and/or
- for consulting services the "Allgemeine Geschäftsbedingungen für Beratungsleistungen für Infrastructure & Industry Geschäft (Deutsches Recht)"¹⁾ (available only in German) and/or
- for other services, the „Supplementary Terms and Conditions for Services for Infrastructure & Industry Business (German Law) ("BL")"¹⁾ and/or
- for other products the "General Conditions for the Supply of Products and Services of the Electrical and Electronics Industry"¹⁾.
In case such products should contain Open Source Software, the conditions of which shall prevail over the "General Conditions for the Supply of Products and Services of the Electrical and Electronics Industry"¹⁾, the Product will be given a note as to which special conditions apply to this open source software. This shall apply mutatis mutandis for notices referring to other third-party software components.

1.2 For customers with a seat or registered office outside European Union

For customers with a seat or registered office outside European Union, the following terms and conditions apply subordinate to T&C:

- for products, which include specific terms and conditions in the description text, these specific terms and conditions shall apply and subordinate thereto,
- for consulting services the "Standard Terms and Conditions for Consulting Services for Infrastructure & Industry Business (Swiss Law)"¹⁾ and/or
- for other services the "International Terms & Conditions for Services"¹⁾ supplemented by "Software Licensing Conditions"¹⁾ and/or
- for other products the "International Terms & Conditions for Products"¹⁾ supplemented by "Software Licensing Conditions"¹⁾

1.3 For customers with master or framework agreement

To the extent products offered are covered by an existing master or framework agreement, the terms and conditions of that agreement shall apply instead of T&C.

2. Prices

The prices are in € (Euro) ex point of delivery, exclusive of packaging.

The sales tax (value added tax) is not included in the prices. It shall be charged separately at the respective rate according to the applicable statutory legal regulations.

Prices are subject to change without prior notice. We will charge the prices valid at the time of delivery.

To compensate for variations in the price of raw materials (e.g. silver, copper, aluminum, lead, gold, dysprosium and neodym), surcharges are calculated on a daily basis using the so-called metal factor for products containing these raw materials.

A surcharge for the respective raw material is calculated as a supplement to the price of a product if the basic official price of the raw material in question is exceeded.

The metal factor of a product indicates the basic official price (for those raw materials concerned) as of which the surcharges on the price of the product are applied, and with what method of calculation. The metal factor, provided it is relevant, can be found in the respective product description.

An exact explanation of the metal factor can be downloaded at: https://mall.industry.siemens.com/legal/ww/en/terms_of_trade_en.pdf

To calculate the surcharge (except in the cases of copper, dysprosium and neodym), the official price from the day prior to that on which the order was received or the release order was effected is used.

To calculate the surcharge applicable to copper, the official price from two days prior to that on which the order was received or the release order was effected is used.

To calculate the surcharge applicable to dysprosium and neodym ("rare earths"), the corresponding three-month basic average price in the quarter prior to that in which the order was received or the release order was effected is used with a one-month buffer (details on the calculation can be found in the explanation of the metal factor).

3. Additional Terms and Conditions

The dimensions are in mm. In Germany, according to the German law on units in measuring technology, data in inches apply only to devices for export.

Illustrations are not binding.

Insofar as there are no remarks on the individual pages of this catalog – especially with regard to data, dimensions and weights given – these are subject to change without prior notice.

¹⁾ The text of the Terms and Conditions of Siemens AG can be downloaded at https://mall.industry.siemens.com/legal/ww/en/terms_of_trade_en.pdf

Appendix

Conditions of sale and delivery

4. Export Control and Sanctions Compliance

4.1 General

Customer shall comply with all applicable sanctions, embargoes and (re-)export control laws and regulations, and, in any event, with those of the European Union, the United States of America and any locally applicable jurisdiction (collectively "Export Regulations").

4.2 Checks for Products

Prior to any transaction by customer concerning products (including hardware, documentation and technology) delivered by Siemens, or products (including maintenance and technical support) performed by Siemens with a third party, customer shall check and certify by appropriate measures that

- (i) the customer's use, transfer, or distribution of such products, the brokering of contracts or the provision of other economic resources in connection with products will not be in violation of any Export Regulations, also taking into account any prohibitions to circumvent these (e.g., by undue diversion)
- (ii) the products are not intended or provided for prohibited or unauthorized non-civilian purposes (e.g. armaments, nuclear technology, weapons, or any other usage in the field of defense and military);
- (iii) customer has screened all direct and indirect parties involved in the receipt, use, transfer, or distribution of the products against all applicable restricted party lists of the Export Regulations concerning trading with entities, persons and organizations listed therein and
- (iv) products within the scope of items-related restrictions, as specified in the respective annexes to the Export Regulations, will not, unless permitted by the Export Regulations, be
 - (a) exported, directly or indirectly (e.g., via Eurasian Economic Union (EAEU) countries), to Russia or Belarus, or
 - (b) resold to any third party business partner that does not take a prior commitment not to export such products to Russia or Belarus.

4.3 Non-Acceptable Use of Software and Cloud Services

Customer shall not, unless permitted by the Export Regulations or respective governmental licenses or approvals,

- (i) download, install, access or use the products from or in any location prohibited by or subject to comprehensive sanctions or subject or to license requirements according to the Export Regulations;
 - (ii) grant access to, transfer, (re-)export (including any "deemed (re-)exports"), or otherwise make available the products to any entity, person, or organization identified on a restricted party list of the Export Regulations;
 - (iii) use the products for any purpose prohibited by the Export Regulations (e.g. use in connection with armaments, nuclear technology or weapons);
 - (iv) upload to a products platform any customer content unless it is non-controlled (e.g. in the EU: AL = N; in the U.S.: ECCN = N or EAR99);
 - (v) facilitate any of the afore mentioned activities by any user.
- Customer shall provide all users with all information necessary to ensure compliance with the Export Regulations.

4.4 Semiconductor Development

Customer will not, without advance written authorization from Siemens, use offerings for the development or production of integrated circuits at any semiconductor fabrication facility located in China meeting the criteria specified in the U.S. Export Administration Regulations, 15 C.F.R. 744.23.

4.5 Information

Upon request by Siemens, customer shall promptly provide Siemens with all information pertaining to users, the intended use and the location of use or the final destination (in the case of hardware, documentation and technology) of the products. Customer will notify Siemens prior to customer disclosing any information to Siemens that is defense-related or requires controlled or special data handling pursuant to applicable government regulations, and will use the disclosure tools and methods specified by Siemens.

4.6 Reservation

Siemens shall not be obligated to fulfill this agreement if such fulfillment is prevented by any impediments arising out of national or international foreign trade or customs requirements or any embargoes or other sanctions. Customer acknowledges that Siemens may be obliged under the Export Regulations to limit or suspend access by customer and/or users to products.

5. Miscellaneous

Errors excepted and subject to change without prior notice.

Selection and ordering at Siemens SiePortal – Ordering products and downloading catalogs

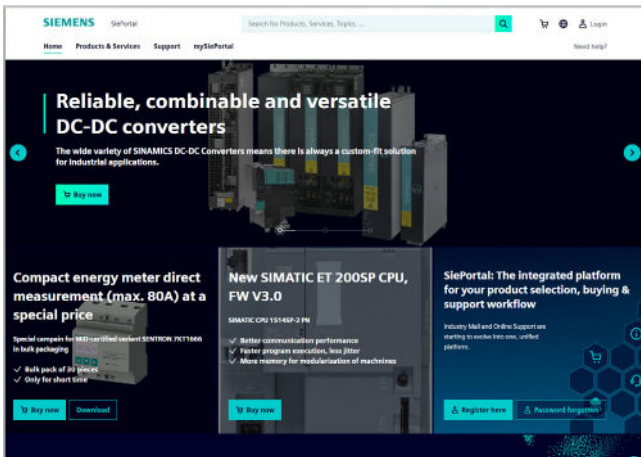

Easy product selection and ordering with SiePortal

SiePortal > Products & Services

The internet ordering platform of Siemens AG is located in SiePortal. It provides you with online access to a comprehensive product spectrum that is presented in an informative, well-organized way.

Powerful search functions help you select the required products, while configurators enable you to configure complex product and system components quickly and easily. CAX data are also available for you to use.

Data transfer allows the entire procedure, from selection through ordering to tracking and tracing, to be carried out online. Availability checks, individual customer discounting, and quotation preparation are also possible.

<https://sieportal.siemens.com>

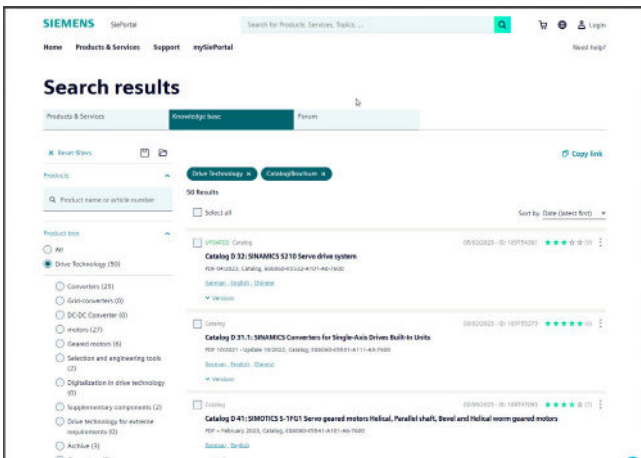

Downloading catalogs

SiePortal > Support > Knowledge base

You can download catalogs and brochures in PDF format from Siemens Industry Online Support without having to register.

The filter box makes it possible to perform targeted searches.

<https://sieportal.siemens.com>

Cybersecurity information

Siemens provides products and solutions with industrial cybersecurity functions that support the secure operation of plants, systems, machines and networks.

In order to protect plants, systems, machines and networks against cyber threats, it is necessary to implement – and continuously maintain – a holistic, state-of-the-art industrial cybersecurity concept. Siemens' products and solutions constitute one element of such a concept.

Customers are responsible for preventing unauthorized access to their plants, systems, machines and networks. Such systems, machines and components should only be connected to an enterprise network or the internet if and to the extent such a connection is necessary and only when appropriate security measures (e.g. firewalls and/or network segmentation) are in place.

For additional information on industrial cybersecurity measures that may be implemented, please visit www.siemens.com/cybersecurity-industry

Siemens' products and solutions undergo continuous development to make them more secure. Siemens strongly recommends that product updates are applied as soon as they are available and that the latest product versions are used. Use of product versions that are no longer supported, and failure to apply the latest updates may increase customer's exposure to cyber threats.

To stay informed about product updates, subscribe to the Siemens Industrial Cybersecurity RSS Feed under www.siemens.com/cert

Get more information

SINAMICS G220 built-in and wall-mounted units:

www.siemens.com/sinamics-g220

SIMOTICS electric motors:

www.siemens.com/simotics

Motion Control Systems and Solutions for production machine and machine tool equipment:

www.siemens.com/motioncontrol

Local partners worldwide:

www.siemens.com/automation-contact

Published by
Siemens AG

Digital Industries
Motion Control
Postfach 31 80
91050 Erlangen, Germany

For the U.S. published by
Siemens Industry Inc.

100 Technology Drive
Alpharetta, GA 30005
United States

PDF (Article No. E86060-K5536-A111-A3-7600)
V6.MKKATA.GMC.600
KG 0624 112 En
Produced in Germany
© Siemens 2024



Subject to changes and errors. The information given in this document only contains general descriptions and/or performance features which may not always specifically reflect those described, or which may undergo modification in the course of further development of the products. The requested performance features are binding only when they are expressly agreed upon in the concluded contract.

All product designations may be trademarks or product names of Siemens AG or other companies whose use by third parties for their own purposes could violate the rights of the owners.