

PRODUCT OVERVIEW

All solutions at a glance.



CONTENTS

Protecting - Switching - Monitoring Product overview

0 Introduction		
Contents	2	
The company	4	
Technical information	6	
1 Circuit breakers & circuit protectors		
Overview	12	
1.1 Thermal circuit breakers		
104/105/106	14	
1110	14	
1140-E/-F/-G	16	
1140-G15	16	
1160	16	
1170/1176	16	
1180	18	
1410-F	18	
1410-L/-G	18	
1610/1616	18	
1620/1626	20	
1658	20	
3120-N	20	
3130	20	
3131	22	
3140	22	
4130	22	
2-5700	22	
1.2 Thermal-magnetic circuit breakers		
201	24	
2210-S	24	
2210-T	26	
2215	26	
2216-S	26	
3120-N-...M1	26	
3300/3400/3600/3900	28	
4230-T	28	
1.3 Magnetic and hydraulic-magnetic circuit breakers		
808	30	
8340-G	30	
8340-F	32	
8340-T	32	
8345	32	
1.4 High performance CBEs		
410/520/530	34	
412/413	34	
437	36	
446/447/449	36	
452	36	
482	36	
483/583	38	
4120	38	
4140/5140	38	
9510	38	
1.5 Power entry modules		
X3120/X3130	40	
XR38	40	
2 Electronic overcurrent protection AC and DC		
Overview	42	
2.1 DC electronic overcurrent protection		
ESS22-T	44	
ESS30-S	44	
ESS31-T	46	
ESX10/ESX10-S	46	
ESX10-T	46	
REF16-S	46	
EM12-T	48	
PM12	48	
REX12-T	48	
REX22D	48	
2.2 AC electronic overcurrent protection		
EBU10-T	50	

3 Relays	SVS04	74	CPC12	94
Overview	SVS25	74	REX12D	94
			REX22D	94
3.1 Solid state relays	4.2 Customer-specific		5.3 CPC20 ControlPlex® System	
ESR10	system solutions		Overview	96
	Overview	76		
3.3 Timer relays	4.3 Power-D-Box® Systems		18plus module	98
ETR10	Overview	78	ESX60D	98
			CPC20	98
3.4 Special relays	Power-D-Box®		5.4 ControlPlex® Rack	
EXR10	PCB-based version	80	Overview	100
3.5 Power relays	Power-D-Box® Economy	80		
MPR10/MPR20	Power-D-Box® High Power	80	Power-D-Box® CP	102
HPR10	Power Distribution Module	80	ESX300-S minus/plus	102
EPR10			EAI300	102
	5 Intelligent power distribution		RCI11/RSI10	102
3.6 High voltage relays	systems			
HVR10	Overview	82	5.5 PowerPlex® Systems	
			Overview	104
3.7 Solid state remote	5.1 Smart Control Systems® SCS		PowerPlex® HMI Solution	106
power controllers	Overview	84	PowerPlex® Power Module	106
E-1048-S6	SCS200	86	PowerPlex® Suite	106
E-1048-S7	SCS1000	86	PowerPlex® Service/Support	106
E-1072-128	SCS3000	86		
E-1048-8I			5.6 E-BOX	
E-1072-100	5.2 EM12D ControlPlex® System		Overview	108
	Overview	88	E-BOX® Module	108
4 Conventional power	EM12D	90	E-BOX® Panel	108
distribution systems	PM12	90		
Overview	REX12D	90	6 Subsidiaries and representatives	
	REX22D	90	Contact	110
4.1 Power distribution	5.2 CPC12 ControlPlex® System			
systems/modules	Overview	92		
Overview				
Module 17plus				
Module 18plus				

WE PROTECT LIVES AND ASSETS

E-T-A secures your products and your success



Founded in 1948, E-T-A pioneered in the development of precision performance circuit breakers for equipment protection and is now the market leader in the field of overcurrent protection and power distribution. We produce a wide range of circuit breakers for equipment protection, solid state relays and remote power controllers as well as system solutions for the global markets in our production facilities in Germany, Tunisia, Indonesia and the USA. Our products are sold by a world-wide network of E-T-A subsidiaries, representatives and sales partners.

E-T-A products provide protection. In everything we do, with each and every unit we produce that our customers install in their applications, we protect people and machines against the effects of overcurrent and

short circuit. For this purpose, we offer mechanical and electronic solutions, single components or entire systems, standardised or customer-specific products. We ensure that the current, without which our modern life is simply unthinkable, remains manageable and that it does not cause any damage in the event of a failure.

We always strive to protect life and limb. But it is also a matter of protecting assets. We ensure that the equipment, machines and vehicles where our devices are installed do not get damaged and that they function and work constantly and that they are paid off in the end.







We make sure that all things equipped with our products are more reliable, more capable and above all

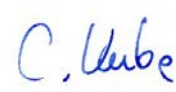

Back row from left to right:
 Ralf Dietrich, Christian Kube, Dr. Clifford Sell
 Front row from left to right:
 Dr. Bernd Bernecker, Dr. Jennifer Sell,
 Manfred Kiefl, Sandra Nowey,

safer, whether it is a production line, a garden shredder, a truck or an aircraft.

We know that you want to offer your customers the best possible solution. You'll manage even better by using E-T-A's high quality solutions. We hope we can support you with our products and make the world a little safer. Please do not hesitate to get in touch.

The E-T-A Elektrotechnische Apparate GmbH
 Management Board

TECHNICAL INFORMATION

The right E-T-A product for every application. We offer many products in the circuit breaker and monitoring equipment area for just as many markets and applications. Unlike devices for the undifferentiated mass market, E-T-A solutions are customised for the respective application in terms of protecting, switching and monitoring.

E-T-A focuses on different business fields to guarantee the best possible support for the individual sectors. Our specialists know their customers' requirements and the challenges of the respective industry. They work closely together with our customers to develop pioneering and sustainable solutions. These are our key markets:

AUTOMATION:

Overcurrent protection and power distribution for the machine building and process control industry

EQUIPMENT:

Medical equipment, professional tools, equipment control

TRANSPORTATION:

Vehicles, aerospace, railway and marine

AUTOMATION

Automation technology is traditionally one of E-T-A's key markets for circuit breakers for equipment protection. E-T-A products provide high performance and cost-saving solutions in a remarkably slim design – particularly suitable for control cabinets, where space is at a premium. Switch mode power supplies with their particular performance characteristics are widely used in the automation industry today. They require a specific protection design to prevent overloaded loads from shutting down complete systems. This a vital aspect when looking at the profitability of plants. E-T-A's electronic circuit breakers provide state-of-the-art protection without compromise.

Efficient, space- and cost-saving installation and wiring of the components is realised in the control cabinet through modular and flexibly designed power distribution systems.

EQUIPMENT

E-T-A offers a wide range of protection equipment for applications in the areas of household and garden appliances and professional tools and equipment, including e.g. circuit breakers for medical equipment, perfectly tailored to the special requirements of this industry.

TRANSPORTATION

E-T-A offers a wide range of products for protecting, switching and monitoring electrical loads in passenger cars and utility vehicles of all kinds (trucks, buses,





© Ondrooo - Getty Images/iStockphoto

construction machinery, agricultural machinery, specialty vehicles). The product portfolio ranges from circuit breakers – as replacement for conventional fuses – to electronic relays, power relays, battery master switches and intelligent CAN power distribution modules.

For aerospace applications, E-T-A supplies special high performance circuit breakers which meet all the requirements of the relevant aircraft standards and which have all necessary approvals required for the installation in all types of aircrafts or helicopters. Some of these products even meet far higher standards than required for civil aviation.

Railway applications include wall socket protection for laptops as well as complete control cabinets for power distribution.

E-T-A has a comprehensive portfolio of circuit breakers for power distribution in boats. One of our most widely used products is our rocker switch with integral overcurrent protection. Our portfolio for the marine industry is completed with bus-controlled systems and battery master switches which were specifically

designed to meet the high requirements of this sector.

QUALITY STRATEGY

E-T-A solutions protect human lives and high material and brand assets. Safety and reliability are the basic requirements in all areas of the company.

Impeccable quality, short delivery times, absolute supply reliability, competitive prices are the pre-requisites for our success on the global markets. All employees at E-T-A share the responsibility for our high quality standards. Based on this, we work together to continuously develop the necessary qualifications and working environments. In this way, we enable all employees to provide and ensure the best performance on their own responsibility. An essential basis is the documentation of our knowledge. Our management board actively live our quality strategy.

Impeccable quality is ensured by robust design, flawless parts and optimised processes. Our products and processes are subject to continuous reviews and improvement. We put our focus on methodical error prevention instead of trouble-shooting.

MAXIMUM RELIABILITY

All of E-T-A's low voltage switchgear is subject to strict quality inspection in our own test laboratory. It is approved according to the DIN EN ISO/IEC 17025 »Allgemeine Anforderungen an die Kompetenz von Prüf- und Kalibrierlaboratorien« ("General requirements for the competence of testing and calibration laboratories") standard. The E-T-A test laboratory has been accredited by the DAkkS ("Deutsche Akkreditierungsstelle - German Accreditation Authority, previously DATech) for the performance of electrical and environmental tests on low voltage switchgear in 1991. Therefore, the E-T-A test laboratory is officially qualified to test circuit breakers and similar devices – both internal and external devices – for conformity with international, European and North American standards. These test results are used for an independent assessment of conformity with EU directives (EU Declaration of Conformity, CE marking, UKCA Declaration of Conformity).

APPROVALS

Many product approvals and conformity marks provide evidence of the high quality standards of E-T-A solutions. Our products are certified with internationally renowned approvals, including e.g. VDE, TÜV (Germany), CSA (Canada), UL (USA), CCC China, KC (Korea). For details on individual devices please see the data sheets.





AT A GLANCE

This product overview shows the essential technical data for our products. You can find further and more detailed technical data sheets on our homepage: www.global.e-t-a.com.

SIDE-BY-SIDE MOUNTING

When several devices are mounted side by side and operated with the same continuous load, there may be a mutual thermal influence. This influence is similar to an increased ambient temperature, depending on the rated current, the number of devices, the distance between them and the ventilation. When mounted side-by-side, the devices can only carry up to 80 % of their rated current or a correspondingly higher dimensioning is required! Please ask for the max. permissible current in your planned side-by-side application.

**TYPICAL APPLICATIONS
INDUCTIVE AND RESISTIVE**

Every circuit typically has a certain inductance which will intensify

arcs. The test specifications of IEC/EN 60934, for example, allow testing with a low-inductance or inductive load and are therefore practice-oriented.

As our devices were tested accordingly, our technical data sheets show values for both (e.g. for typical life) inductive ($\cos \varphi \approx 0.6$, $L/R \approx 2.5$ ms) and resistive loads ($\cos \varphi \approx 1.0$, $L/R \approx 0$ ms).

TEMPERATURE BEHAVIOUR

The typical time/current characteristics normally relate to an ambient temperature of 23 °C. Thermal and thermal-magnetic circuit breakers are, except for very few versions, not temperature compensated and are therefore an exact image of the load to be protected. Their operational behaviour depends on the ambient temperatures. Trip times of thermal devices are faster with higher temperatures and slower with lower temperatures. In order to avoid premature or delayed

disconnection with circuit breakers that are constantly used at high or low ambient temperatures, a certain correction factor must be applied.

Example: $I_N = 10$ A at 50 °C means $10 \text{ A} \times 1.16 = 11.6$ A. A circuit breaker designed for $I_N 12$ A must be used.

Ambient temperature [°C]		Temperature factor (Indicative values)
°C	°F	
-20	-4	0.76
-10	+14	0.84
0	+32	0.92
+23	+73.4	1.00
+40	+104	1.08
+50	+122	1.16
+60	+140	1.24

**BASIC APPLICATION EXAMPLES:
THERMAL CIRCUIT BREAKER (TO)**

The trip time of thermal circuit breakers depends on the level and duration of the overload current. The higher the overcurrent, the faster the bimetal will reach the specified trip temperature. In the event of a low overload it will take longer until the required

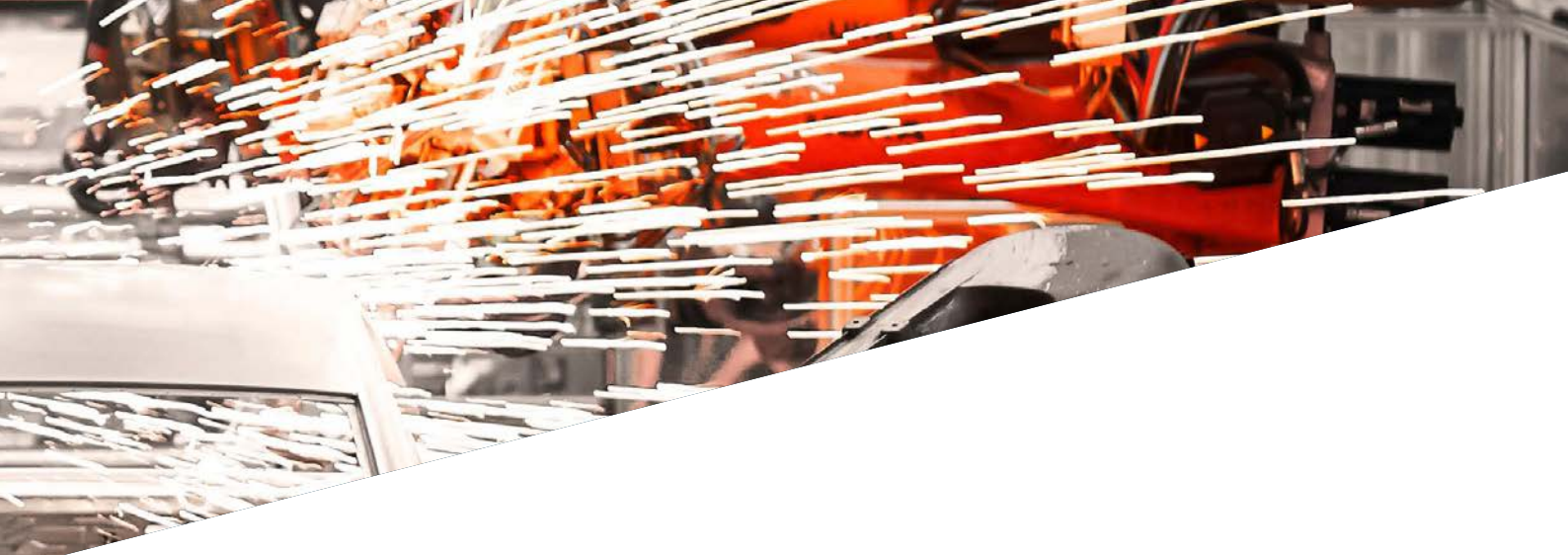

disconnection of potentials takes place. Thermal circuit breakers are recommended for all applications where an overload is expected. They are the perfect solution for loads such as motors, magnetic valves electrical systems and low voltage lines.

THERMAL-MAGNETIC CIRCUIT BREAKERS (TM)

The protective function is achieved by combining temperature and magnetic force. The thermal element of the circuit breakers provides protection in the event of an overload with a delayed trip characteristic. The magnetic part responds without delay to high overload and short circuit currents and disconnects the faulty circuit

within only a few milliseconds. These circuit breakers are perfectly suitable for information and telecommunication technology, process control and similar applications requiring precise functioning even in the event of an overload or a short circuit.

MAGNETIC CIRCUIT BREAKERS (MO)

In the event of a short circuit, they disconnect the faulty circuit nearly without delay. The magnetic system of the circuit breaker is the trip element. As tripping depends on the time curve of the magnetic force and therefore on the magnetic field, the trip limit is influenced by the shape of the current characteristic (AC/DC).

Magnetic circuit breakers are largely insensitive to temperature fluctuations. This operating principle is ideally suited to protect any application with a higher risk of short circuit.

HYDRAULIC-MAGNETIC CIRCUIT BREAKERS (HM)

The protective function of this circuit breaker is achieved by combining hydraulic and magnetic force. A wide range of performance characteristics is available in single, double and three pole configurations. The magnetic part responds without delay to high overload and short circuit currents and disconnects the faulty circuit within only a few milliseconds.

TYPICAL TIME/CURRENT CHARACTERISTIC CURVES

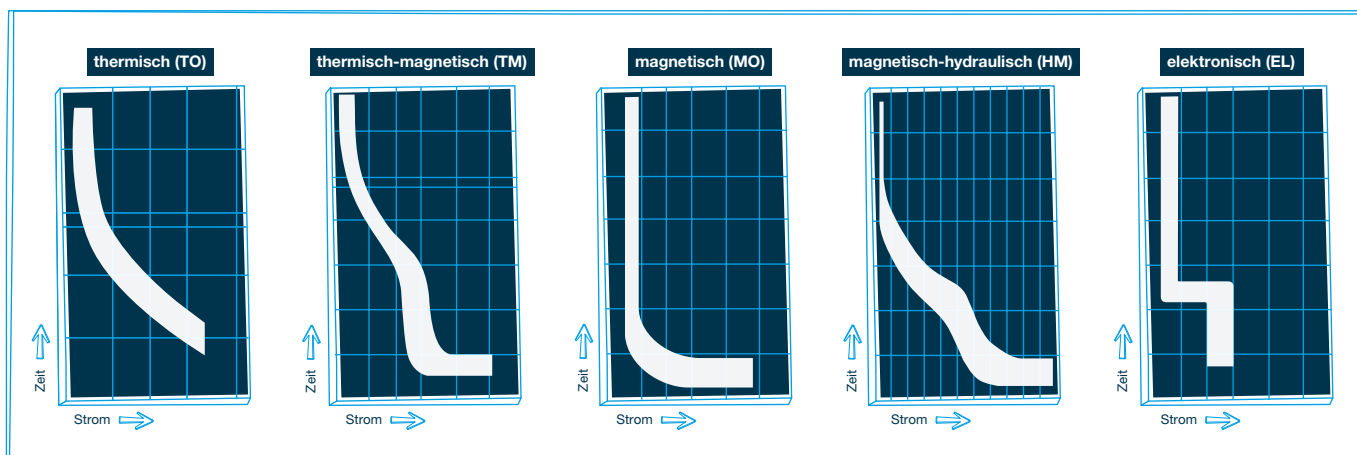

ELECTRONIC OVERCURRENT PROTECTION (EL)

With electronic overcurrent protection the load current is measured with an integral current sensor. In the event of an overload, the circuit will be interrupted after approx. 5 sec even with cable attenuation. In the event of a short circuit in the load circuit, the overcurrent will be limited electrically and then disconnected. This will prevent a voltage dip in the power supply. An electronic circuit breaker will also physically isolate the load circuit in the event of an overcurrent.

Electronic protection is suitable for DC 24 V circuits in automation and process control (PLCs, sensors, bus modules, actuators etc.) or for communication systems (minus DC 48 V).

OPERATIONAL METHODS OF CIRCUIT BREAKERS FOR EQUIPMENT PROTECTION (ACCORDING TO EN 60934)

- R-type: manual reset
- M-type: with manual release but not intended for frequent use as a switch (for service purposes)
- S-type: manual reset and manual switch-off (ON/OFF switch)
- J-type: automatic disconnection and automatic reset

SNAP-ACTION MECHANISM

Circuit breakers with snap-action mechanism ensure that the contact closing speed is independent of the operating speed at which the actuating element (e.g. push button, rocker switch, toggle) is moved in the ON switching direction. The moving contact is mechanically held back until a certain force value is built up by the actuating element in the closing direction of the contacts. Once this force is exceeded, the

mechanical retention is overcome allowing the contacts to snap into closed position (tease-free mechanism). The closing speed is dependent on the built-up closing force. Snap action mechanisms eliminate contact welding upon switching onto sustained short circuits and minimise the risk of contact wear for the entire typical life of the circuit breaker.

TRIP-FREE MECHANISM

Reliable switching behaviour of E-T-A circuit breakers is ensured by a trip-free mechanism independent of external influences. The circuit breaker trips reliably in the event of an overcurrent, even when the actuator (push button, toggle or rocker) is blocked.

AUXILIARY CONTACTS

Some circuit breakers of our portfolio are equipped with auxiliary contacts. The physically isolated contacts are used to initiate alarm and sequential switching or to indicate the main contact position.

TYPICAL INTERNAL RESISTANCE VALUES

The internal resistance values shown are typical values for new devices. They can change depending on storage, typical life or overcurrent. Deviating internal resistance values do not affect the protective function of the circuit breaker.

ACCESSORIES FOR CIRCUIT BREAKERS, CIRCUIT PROTECTORS AND SYSTEM SOLUTIONS

E-T-A offers a comprehensive range of accessories completing our product portfolio, including add-on modules for the undervoltage release or auxiliary contact functions as well as water splash covers, terminal blocks, sockets, busbars, covers, retaining clips, jumpers and many more. For detailed information please refer to the individual technical data sheets of our products, under the "Accessories" section. For further details on our products please visit www.global.e-t-a.com.





Group	Equipment	Transportation	Automation
Group 1			
Thermal circuit breakers (TO)	Medical equipment, Household appliances and garden tools, professional tools, apparatus engineering, office equipment	Passenger cars, buses and trucks, construction machinery, agricultural machinery, specialty vehicles	In individual applications
Thermal-magnetic circuit breakers (TM)	in individual applications	in individual applications	Machine building industry, power engineering, plant construction, process control
Magnetic and hydraulic-magnetic circuit breakers(MO/ MH)	Medical equipment, apparatus engineering	Agricultural machinery, construction machinery, specialty vehicles	power engineering
High performance circuit breakers	–	Aerospace, specialty vehicles, rail vehicles, construction machinery	–
Group 2			
Electronic overcurrent protection DC	–	–	Power engineering, machine building industry, plant construction, process control
Electronic overcurrent protection AC	–	–	Machine building industry, process control
Group 3			
Solid state relays	–	Passenger cars, buses and trucks, construction machinery, agricultural machinery, specialty vehicles	–
Solid state relays / solid state remote power controllers (SSRPC)	–	–	Machine building industry, plant construction, power engineering
Power relays	–	Buses and trucks, construction machinery, agricultural machinery, specialty vehicles	–
High voltage contactor	–	Passenger cars, buses and trucks, construction machinery, agricultural machinery, specialty vehicles	–
Groups 4 and 5			
Standard power distribution systems and intelligent power distribution systems	in applications of all business fields – both as standard systems and as customised solutions (see pages 62 ff.)		

CIRCUIT BREAKERS AND CIRCUIT PROTECTORS

Customised protection against
overcurrent and short circuit



Thermal circuit breakers

Applications: Circuit breakers with a thermal tripping principal ensure the best possible overload protection for electronic motors, transformers, magnetic valves, on-board electrical systems and low voltage lines.

Technology The trip time of thermal circuit breakers and protectors depends on the level/duration of the overload current. A bimetal or hot wire is heated up through increasing current ratings until the defined trip time is reached. The device ensures real disconnection through physical isolation.

Thermal-magnetic circuit breakers

Applications: Thermal-magnetic circuit breakers offer the ideal protection against overcurrent and short circuit. They can be particularly recommended for devices and plants in the information and telecommunications industry, in process control and similar applications requiring precise performance even in the event of overload or short circuit.

Technology The combination of bimetal and magnetic coil in our thermal-magnetic circuit breakers and protectors ensures reliable protection. These devices feature real physical isolation. The bimetal provides delayed protection in the event of an overload. The magnetic coil responds to high overload and short circuit currents without delay and disconnects the faulty circuit within only a few milliseconds.

Magnetic and hydraulic-magnetic circuit breakers

Applications: Magnetic and hydraulic-magnetic circuit breakers are ideally suitable to protect printed circuit boards and semi-conductors against overcurrent and short circuit and are qualified for use in the telecommunications industry.

Technology Circuit breakers and protectors with magnetic or hydraulic-magnetic trip are extremely fast and ensure genuine physical isolation. In the event of a short circuit, but also in the event of smaller overloads, the magnetic trip mechanism will disconnect the faulty circuit nearly without any delay. In the overload range, the hydraulic-magnetic trip offers an intended delay.

High performance circuit breakers

Applications: E-T-A high performance circuit breakers are the perfect choice for overcurrent and short circuit protection in vehicles and aerospace and they serve as alternative for MCBs in process, measuring and control technology.

Technology High performance circuit breakers feature a thermal or thermal-magnetic trip with a particularly high rupture capacity. Isolation switches and battery master switches are based on the thermal-magnetic trip principle. The thermal part of the circuit breakers protects loads with a time delay in the event of an overload. The magnetic part responds without delay to high overload and short circuit currents and disconnects the faulty circuit within only a few milliseconds. All our high performance switches of this category offer genuine physical isolation.

Power entry modules

Applications: E-T-A power entry modules with integral circuit breakers are the best choice when systematic component reduction is a decisive success factor for a cost-saving design. They are used in medical equipment, machine construction, household appliances and garden tools, professional tools and audio equipment.

Technology E-T-A power entry modules include up to five functions in a single component: a C14/C20 appliance inlet, a resettable overcurrent protection, an ON/OFF switch and a line filter, and optionally an undervoltage release, a remote trip module or an auxiliary switch. Unlike standard plug-in modules with fuses, E-T-A power entry modules include a resettable circuit breaker.



Find more information about thermal circuit breakers here: www.global.e-t-a.com/c626

104-PR.../104/105/106



Description

Single pole, thermal resettable circuit breakers in a miniaturised design with different mounting methods. Positively trip-free and snap action mechanisms ensure a reliable switching behaviour. The 106 version can be combined with the XR38 power entry module.

For higher current ratings in a similar design please see type 1140.

Typical applications:

- Medical equipment
- Household appliances and garden tools
- Professional tools
- Office equipment
- Industrial kitchenware
- Apparatus engineering

1110



Description

Single pole, thermal circuit breaker/switch combinations. Also available as reset version. Fast and space-saving vertical mounting through snap-in mounting into the housing cut-out. Reliable and resettable solution perfectly suitable to replace fuses. Positively trip-free and snap action mechanisms ensure a reliable switching behaviour.

Typical applications:

- Household appliances and garden tools
- Industrial kitchenware
- Office equipment
- Equipment control

THERMAL CIRCUIT BREAKERS

A modern classic for a wealth of applications

The trip time of thermal circuit breakers depends on the level/duration of the overload current. A bimetal or hot wire is heated up through increasing current ratings until the defined trip time is reached. Circuit breakers with thermal trip characteristics are suitable for protecting loads such as motors, transformers, on-board electrical systems, magnetic valves and low voltage lines.

Characteristic features

A powerful snap action mechanism ensures that the closing speed of the contacts is independent from the actuating speed. This increases the typical life of the devices.

Thanks to the so-called trip-free mechanism, tripping is guaranteed even if the actuator is blocked. The devices will always trip reliably, regardless of external influences. They are optionally available with auxiliary contacts. They provide various functions, such as alarms and other signalisation functions.

Temperature behaviour

The time/current characteristics are related to an ambient temperature of +23 °C. The trip times are shorter at higher ambient temperatures and longer at lower temperatures. In order to eliminate nuisance tripping with circuit breakers that are constantly used at high or low ambient temperatures, please multiply the rated current of the circuit breaker with a temperature factor (see Technical Information chapter).

Test certificates

Our thermal circuit breakers meet the specifications of the VDE and the EN 60934 (IEC 60934) circuit breaker standard as well as many international and country- or user-specific standards.

For detailed information please refer to the respective data sheet.

Technical data

Rated voltage	AC 240 V/DC 48 V UL/CSA: AC 250 V
Rated current	0.05 A ... 10 A
Breaking capacity I_{cn}	0.05 ... 8 A 6 x I_N (AC) 0.05 ... 10 A 6 x I_N (DC)
Ambient temperature	-20 ... +60 °C
For more information please visit	www.global.e-t-a.com/c626

104 Dimensional drawing example

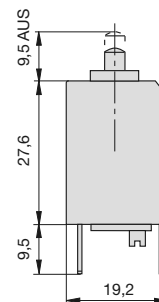

Technical data

Rated voltage	AC 250 V/DC 50 V UL/CSA: DC 50 V
Rated current	0.05 A ... 16 A
Breaking capacity I_{cn}	AC 250 V: 0.05 ... 10 A: 8 x I_N DC 50 V: 0.05 ... 6 A: 10 x I_N 7 ... 16 A: 130 A DC 28 V: 7 ... 10 A: 200 A
Ambient temperature	-20 ... +60 °C
For more information please visit	www.global.e-t-a.com/p39

1110 Dimensional drawing example

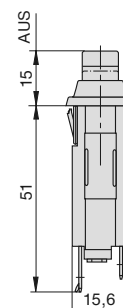

1140-E/-F/-G



Description

Single pole, thermal resettable circuit breakers in a miniaturised design with different mounting methods. Positively trip-free and snap action mechanisms ensure a reliable switching behaviour. The 1140-G version is also available combined with the XR38 power entry module. For smaller current ratings please see 104, 105, 106 devices.

Typical applications:

- Medical equipment
- Professional tools
- Equipment control
- Household appliances and garden tools
- Lighting technology
- Office equipment

1140-G15



Description

Double pole resettable circuit breaker in miniaturised design, one pole thermally protected. Convenient threadneck mounting. Positively trip-free and snap action mechanisms ensure a reliable switching behaviour. The 1140-G15 version is also available combined with the XR38 power entry module.

Typical applications:

- Medical equipment
- Professional tools
- Apparatus engineering
- Household appliances and garden tools
- Lighting technology
- Office equipment

1160

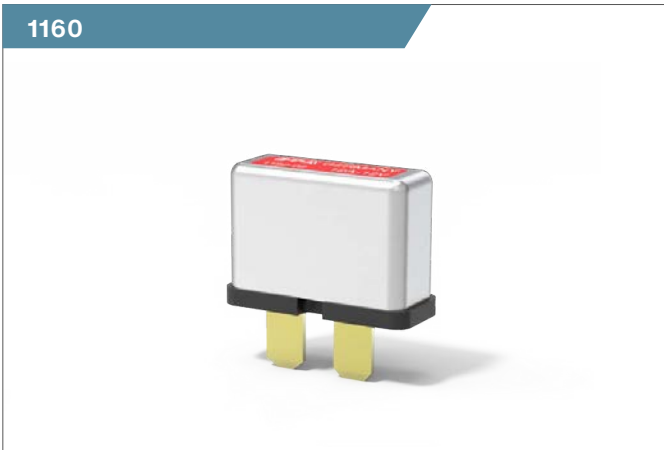

Description

Thermal automotive circuit breaker. In the event of an overload, one contact opens and limits the overcurrent to protect the load. A voltage actuated holding coil ensures that the contacts remain open, preventing an automatic reset. The circuit breaker automatically resets when the supply voltage is switched off for a short time. Particularly suitable for installation in hard to access locations.

Typical applications:

- Passenger cars

1170/1176



Description

Compact single pole thermal circuit breaker with colour coded manual release. Independent trip-free and snap action mechanisms ensure a reliable switching behaviour. Plug-in type for standard automotive fuse blocks. The 1176 version is especially designed for the automotive industry (rated current and trip curves correspond to the blade fuse series), 1170 special version with retaining clips for the use in challenging environmental conditions.

Typical applications:

- Buses and trucks
- Construction machinery
- Specialty vehicles
- Rail vehicles
- Agricultural machinery



Technical data

Rated voltage	AC 240 V/DC 48 V UL/CSA: AC 250 V UL/CSA: DC 50 V
Rated current	3.5 A ... 16 A
Breaking capacity I_{cn}	3.5 ... 8 A: $8 \times I_N$ 9 ... 16 A: 120 A
Ambient temperature	-20 ... +60 °C
For more information please visit	www.global.e-t-a.com/p41

1140-F Dimensional drawing example

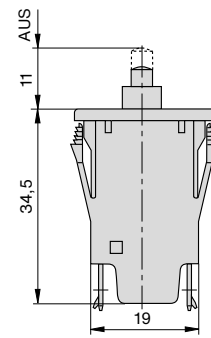

Technical data

Rated voltage	AC 240 V/DC 48 V UL/CSA: AC 250 V UL/CSA: DC 50 V
Rated current	0.05 A ... 16 A
Breaking capacity I_{cn}	0.05 ... 3 A: $6 \times I_N$ 3.5 ... 8 A: $8 \times I_N$ 9 ... 16 A: 120 A
Ambient temperature	-20 ... +60 °C
For more information please visit	www.global.e-t-a.com/p43

1140-G15 Dimensional drawing

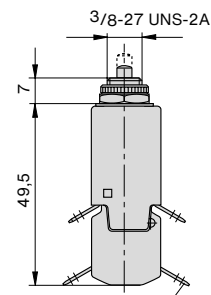

Technical data

Rated voltage	DC 12 V
Rated current	12 A ... 30 A
Breaking capacity I_{cn}	200 A, L/R = 2.5 ms
Ambient temperature	-30 ... +60 °C
For more information please visit	www.global.e-t-a.com/p44

1160 Dimensional drawing

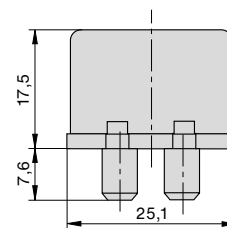

Technical data

Rated voltage	DC 12 V, DC 24 V, DC 48 V
Rated current	between 3 A ... 25 A
Breaking capacity I_{cn}	400 A
Ambient temperature	-40 ... +85 °C
For more information please visit	www.global.e-t-a.com/p45

1170 Dimensional drawing example

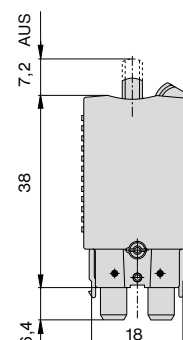

1180



Description

Miniaturised single pole thermal circuit breaker with switching function optional (push-push actuation). Independent trip-free and snap action mechanisms ensure a reliable switching behaviour. Can be plugged into fuse terminal blocks for DIN rail mounting.

Typical applications:

- Machine building industry
- Plant engineering
- Process control
- Power engineering

1410-F1



Description

Single pole, thermal circuit breaker-/switch combinations. Time-saving snap-in mounting. Very fast trip characteristic through specific trip mechanism, low temperature sensitivity. Illumination of the rocker actuator is also available. Positively trip-free and snap action mechanisms ensure a reliable switching behaviour.

Typical applications:

- Medical equipment
- Lighting engineering
- Household appliances and garden tools
- Equipment control

1410-L1/-L2/-G1

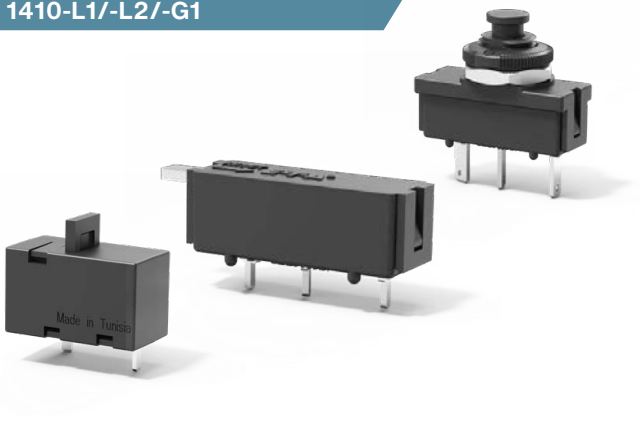

Description

Single-pole, resettable thermal circuit breakers in a very compact, miniaturised design with different mounting methods. Very fast trip characteristic through specific trip mechanism, low temperature sensitivity. Positively trip-free and snap action mechanisms ensure a reliable switching behaviour.

Typical applications:

- Medical equipment
- Lighting engineering
- Household appliances and garden tools
- Equipment control

1610/1616



SAE type 1 (1610) SAE type 3 (1616) SAE type 3H (1610)

Description

Single pole thermal automotive circuit breaker in a miniaturised design, colour coded housing caps or manual release buttons are optionally available. Blade terminals fit into standard automotive fuse blocks according to ISO 8820 part 3, type C. The 1616 module is specifically designed for the automotive industry (current ratings and trip characteristics correspond to those of the blade fuses series). Meets the SAE J553 or ISO 10924 requirements.

Typical applications:

- Buses and trucks
- Passenger cars
- Specialty vehicles
- Construction machinery
- Agricultural machinery



Technical data

Rated voltage	AC 250 V/DC 65 V UL, UL Canada: DC 72 V
Rated current	between 0.1 A ... 10 A
Breaking capacity I_{cn}	0.1 ... 5 A $6 \times I_N$ AC 250 V, DC 65 V 6 ... 10 A $8 \times I_N$ AC 250 V, DC 65 V 0.1...0.7 A $25 \times I_N$ DC 30 V 0.8...6 A $10 \times I_N$ DC 30 V 7...10 A $20 \times I_N$ DC 30 V
Ambient temperature	-20 ... +60 °C
For more information please visit	www.global.e-t-a.com/p46

1180 Dimensional drawing

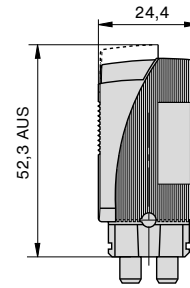

Technical data

Rated voltage	UL: AC 250 V, DC 50 V, DC 60 V CSA: AC 125 V, DC 48 V
Rated current	between 0.63 A ... 10 A
Breaking capacity I_{cn}	0.63 ... 2 A: $12 \times I_N$ 2.5 ... 8 A: $8 \times I_N$ AC, max. 50 A 10 A: $6 \times I_N$ AC 3.15 ... 10 A: $10 \times I_N$ DC
Ambient temperature	-20 ... +70 °C
For more information please visit	www.global.e-t-a.com/p47

1410-F1 Dimensional drawing

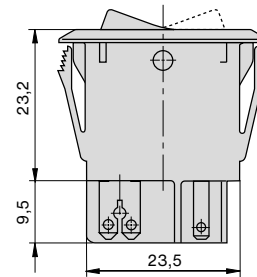

Technical data

Rated voltage	AC 240 V/DC 28 V/DC 50 V UL/CSA: AC 250 V/DC 50 V
Rated current	between 0.63 A ... 10 A
Breaking capacity I_{cn}	0.63 ... 2 A: $12 \times I_N$ 2.5 ... 8 A: $8 \times I_N$ AC, max. 50 A 10 A: $6 \times I_N$ AC 3.15 ... 10 A: $10 \times I_N$ DC
Ambient temperature	-20 ... +70 °C
For more information please visit	www.global.e-t-a.com/p49

1410-L2 Dimensional drawing example

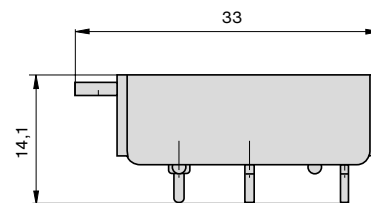

Technical data

Rated voltage	DC 12 V (1610/1616-92) DC 24 V (1610/1616-21/-H2)
Rated current	between 5 A ... 40 A
Breaking capacity I_{cn}	≥ 3 break operations at 150 A or ≥ 1 break operation at 2 000 A
Ambient temperature	-40 ... +85 °C
For more information please visit	www.global.e-t-a.com/c626

1610-H2 Dimensional drawing example

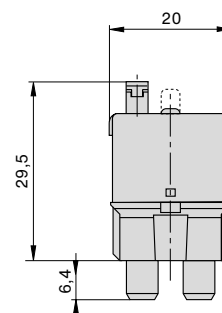

1620/1626



SAE type 1 SAE type 2 SAE type 3

Description

Single pole, thermal miniaturised circuit breaker for automotive applications. The reversible device fits into fuse holders designed for fuse blocks according to ISO 8820-3, F type. The product is available with automatic reset (for DC 12 V only) and hold-open function. The circuit breaker will reset after the load is removed. Current ratings of the 1616 version correspond to those of blade fuses. Meets the SAE J553 or ISO 10924 requirements.

Typical applications:

- Buses and trucks
- Passenger cars
- Agricultural machinery
- Specialty vehicles
- Construction machinery

1658



Description

Single pole, resettable thermal circuit breakers, cost-optimised design. Various mounting methods. Reliable switching behaviour through trip-free and snap-action mechanisms.

Typical applications:

- Medical equipment
- Household appliances and garden tools
- Professional tools
- Equipment control

3120-N



Description

Single to three pole, thermal circuit breaker-/switch combinations. Time-saving snap-in mounting. Rocker or push button actuation. Optionally with illumination, water splash/dust protection and add-on modules e.g. undervoltage release module. Reliable switching behaviour through trip-free mechanism. The 3120 version is also available combined with the X3120 power entry module. For a thermal-magnetic design please see 3120-N...-M.

Typical applications:

- Medical equipment
- Office equipment
- Industrial kitchenware
- Professional tools
- Equipment control
- Domestic appliances and garden tools

3130



Description

Single to three pole, thermal circuit breaker-/switch combinations. Time-saving snap-in mounting. Rocker or push button actuation. Optionally available with illumination and splash water/dust protection cover. Reliable switching behaviour through trip-free mechanism. The 3130 version is also available combined with the X3130 power entry module.

Typical applications:

- Medical equipment
- Office equipment
- Industrial kitchenware
- Professional tools
- Equipment control
- Domestic appliances and garden tools



Technical data

Rated voltage	DC 12 V (1620/1626-1/-2) DC 24 V (1620/1626-3)
Rated current	between 5 A ... 30 A DC 12 V between 5 A ... 25 A DC 24 V
Breaking capacity I_{cn}	≥ 3 disconnections at 150 A or ≥ 1 break operation at 2 000 A
Ambient temperature	-40 ... +85 °C
For more information please visit	www.global.e-t-a.com/p1282 (1620) www.global.e-t-a.com/p1283 (1626)

1620 Dimensional drawing example

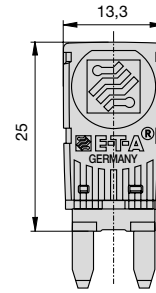

Technical data

Rated voltage	AC 240 V DC 28 V UL: DC 32 V
Rated current	between 5 A ... 30 A
Breaking capacity I_{cn}	5 ... 7 A: 180 A 8 ... 30 A: 200 A
Ambient temperature	-20 ... +60 °C
For more information please visit	www.global.e-t-a.com/p54

1658 Dimensional drawing

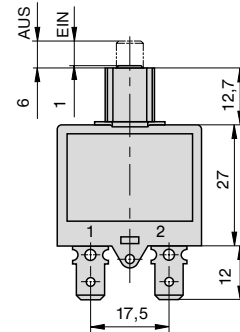

Technical data

Rated voltage	AC 240 V (AC 415 V upon request)/DC 50 V UL/CSA: AC 250 V
Rated current	between 0.1 A ... 20 A (up to 30 A upon request, single-pole units only)
Breaking capacity I_{cn}	0.1 ... 2 A: 10 times rated current 2.5 ... 20 A: 200 A 1-pole 2.5 ... 20 A: 300 A 2-pole
Ambient temperature	-30 ... +60 °C
For more information please visit	www.global.e-t-a.com/p6373

3120-N3.4-G7 Dimensional drawing example

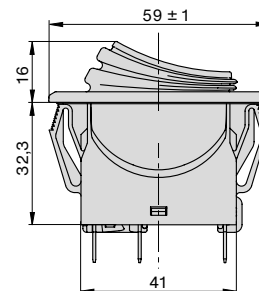

Technical data

Rated voltage	AC 240 V, 3 AC 415 V UL/CSA: AC 250 V, AC 277 V, DC 50 V
Rated current	between 0.1 A ... 20 A (1-pole) 0.1 A ... 16 A (2- and 3-pole)
Breaking capacity I_{cn}	0.1 ... 2 A: 10 times rated current 2.5 ... 20 A: 200 A 1-pole 2.5 ... 16 A: 300 A 2-pole 2.5 ... 12 A: 150 A (3-pole)
Ambient temperature	-30 ... +60 °C
For more information please visit	www.global.e-t-a.com/p58

3130-F1 Dimensional drawing example

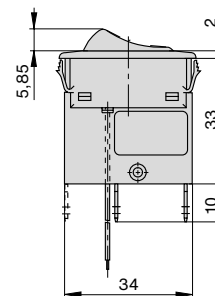

3131



Description

Single pole, thermal circuit breaker-/switch combinations. Time-saving snap-in mounting, high degree of protection (IP66). Illumination optional. Wide range of rocker markings. Also available as a three-position switch. Reliable switching behaviour through trip-free mechanism.

Typical applications:

- Equipment control
- Specialty vehicles
- Work boats
- Agricultural machinery
- Leisure boats
- Recreational vehicles
- Construction machinery

3140



Description

Three-pole thermal circuit breaker-/switch combination with push button actuation. Time-saving snap-in mounting, high degree of protection (IP66). Add-on modules optionally available, e.g. undervoltage release module. Reliable switching behaviour through trip-free mechanism.

Typical applications:

- Household appliances and garden tools
- Professional tools

4130



Description

Single pole thermal resettable circuit breaker with high current ratings. Convenient threadneck mounting. Positively trip-free and snap action mechanisms ensure a reliable switching behaviour.

Typical applications:

- Professional tools
- Equipment control
- Construction machinery
- Agricultural machinery
- Specialty vehicles

2-5700



Description

Single pole, resettable, thermal circuit breaker. Also available as push-push version, i.e. with manual switch-off option, upon request. Positively trip-free and snap action mechanisms ensure a reliable switching behaviour. The 2-5700 version is also available combined with the XR38 power entry module.

Typical applications:

- Household appliances and garden tools
- Equipment control
- Agricultural machinery
- Construction machinery
- Specialty vehicles



Technical data

Rated voltage	AC 240 V/DC 28 V
Rated current	between 0.1 A ... 20 A
Breaking capacity I_{cn}	0.1 ... 2 A: $10 \times I_N$ 2.5 ... 20 A / 200 A
Ambient temperature	-20 ... +60 °C
For more information please visit	www.global.e-t-a.com/p1041 (3131-A) www.global.e-t-a.com/p1042 (3131-B)

3131 Dimensional drawing

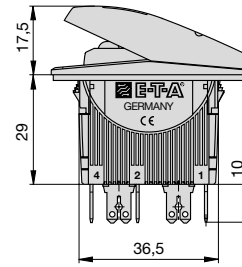

Technical data

Rated voltage	3 AC 415 V
Rated current	between 0.1 A ... 16 A
Breaking capacity I_{cn}	0.1 ... 2 A: $10 \times I_N$ 2.5 ... 16 A: 150 A
Ambient temperature	-30 ... +60 °C
For more information please visit	www.global.e-t-a.com/p60

3140 Dimensional drawing

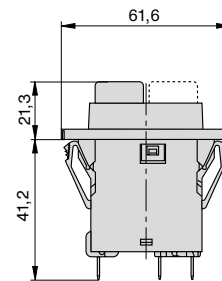

Technical data

Rated voltage	AC 240 V/DC 50 V
Rated current	between 20 A ... 70 A
Breaking capacity I_{cn}	800 A
Ambient temperature	-30 ... +60 °C
For more information please visit	www.global.e-t-a.com/p62

4130 Dimensional drawing

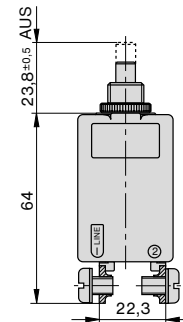

Technical data

Rated voltage	AC 250 V/DC 28 V UL/CSA: DC 50 V
Rated current	between 0.05 A ... 25 A
Breaking capacity I_{cn}	0.05 ... 2.5 A: 8 times rated current 3 ... 5 A: 20 times rated current 6 ... 12 A: 200 A 13 ... 25 A: 300 A
Ambient temperature	-20 ... +60 °C
For more information please visit	www.global.e-t-a.com/p65

2-5700 Dimensional drawing example

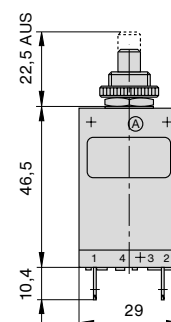



Find more information about thermal-magnetic circuit breakers here: www.global.e-t-a.com/c625

201



Description

Single pole, thermal-magnetic circuit breaker with manual release button and DIN rail mounting. Independent trip-free and snap action mechanisms ensure a reliable switching behaviour. The very compact device is perfectly suited for basic applications without auxiliary contact.

Typical applications:

- Machine building industry
- Plant engineering

2210-S



Description

Single and multipole, thermal-magnetic circuit breakers with toggle actuation, socket or front panel mounting, positively trip-free mechanism, different characteristic curves and all-pole tripping. Optionally available with auxiliary contacts and intermediate positions. Also suitable for power distribution systems.

Typical applications:

- Machine building industry
- Plant engineering
- Process control
- Power engineering

THERMAL-MAGNETIC CIRCUIT BREAKERS

Precise performance for tailor-made protection

The protective function of thermal-magnetic circuit breakers is provided by a combination of bimetal and magnetic coil. The thermal element provides delayed protection in the event of an overload. The magnetic part responds without delay to high overload and short circuit currents and disconnects the faulty circuit within only a few milliseconds. These circuit breakers are perfectly suitable for information and telecommunication technology, process control and similar applications requiring reliable functioning in the event of an overload or a short circuit.

Characteristic features

- Overload ON/OFF switching
- A (positively) trip-free mechanism independent of external influences. The protective function will trip independently of external influences, even if the actuator is blocked.
- Standard devices are optionally equipped with up to two physically isolated auxiliary contacts. They offer various signalisation and alarm functions.

Temperature behaviour

- The time/current characteristics are related to an ambient temperature of +23 °C. In the event of an overload, the trip times are shorter at higher ambient temperatures and longer at lower ambient temperatures. In order to eliminate nuisance tripping, please multiply the rated current of the circuit breaker with a temperature factor (see Technical Information chapter).

Time/current characteristics

- The magnetic trip currents normally refer to AC current. In case of DC supplies, the magnetic trip currents are 1.2 times higher.

Test certificates

- Thermal-magnetic circuit breakers meet the specifications of the VDE and the EN 60934 (IEC 60934) standard as well as many international, country- or user-specific standards. For detailed information please refer to the respective data sheet.

Technical data

Rated voltage	AC 240 V (50/60 Hz) / DC 65 V UL/CSA: AC 250 V UL/CSA: DC 80 V
Rated current	between 0.05 A ... 16 A
Breaking capacity I_{cn}	0.05 ... 0.8 A: self-limiting 1 ... 2 A: 200 A/2.5 ... 16 A: 400 A
Ambient temperature	-30 ... +60 °C
For more information please visit	www.global.e-t-a.com/p3693

Technical data

Rated voltage	3 AC 433 V (50/60 Hz) AC 250 V/DC 65 V (higher voltages upon request) UL: AC 277/480 V
Rated current	between 0.1 A ... 25 A
Breaking capacity I_{cn}	0.1 ... 5 A: 400 A/6 ... 25 A: 800 A 0.1 ... 16 A: 2,500 A (at DC 32 V)
Ambient temperature	-30 ... +60 °C
For more information please visit	www.global.e-t-a.com/p69

201 Dimensional drawing

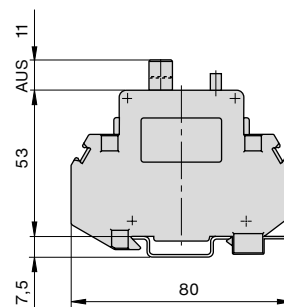

2210-S Dimensional drawing

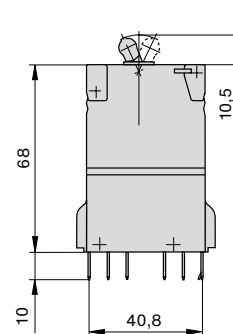

2210-T2



Description

Single and multipole, thermal-magnetic circuit breakers with toggle actuation, DIN rail mounting, positively trip-free mechanism, different characteristic curves and all-pole tripping. Optionally available with auxiliary contacts.

Typical applications:

- Machine building industry
- Plant engineering
- Process control
- Power engineering
- Rail technology

2215



Description

Single pole thermal-magnetic circuit breaker with toggle actuation, designed for PCB mounting, trip-free mechanism, various trip curves and optionally with auxiliary contacts. Also suitable for power distribution systems.

Typical applications:

- Plant engineering
- Process control

2216-S



Description

Single or double pole thermal-magnetic circuit breaker with slide actuation in a compact design, trip-free mechanism, various trip curves and optional auxiliary contacts.

Typical applications:

- Machine building industry
- Plant engineering
- Process control
- Power engineering
- Rail engineering
- Equipment control

3120-N-...M1



Description

Circuit breaker/ON/OFF switch combination with rocker or push button, double pole (first pole: thermal-magnetically protected, second pole: thermally protected or unprotected), front panel mounting. The rocker or button can optionally be supplied with illumination and in a range of colours. Reliable switching behaviour through trip-free mechanism.

Typical applications:

- Machine building industry



Technical data

Rated voltage	3 AC 433 V (50/60 Hz) AC 250 V/DC 65 V (higher voltages upon request) UL/CSA: AC 277/480 V
Rated current	between 0.1 A ... 32 A
Breaking capacity I_{cn}	0.1 ... 5 A: 400 A/6 ... 32 A: 800 A 0.1 ... 16 A: 2,500 A (at DC 32 V)
Ambient temperature	-30 ... +60 °C
For more information please visit	www.global.e-t-a.com/p71

2210-T2 Dimensional drawing

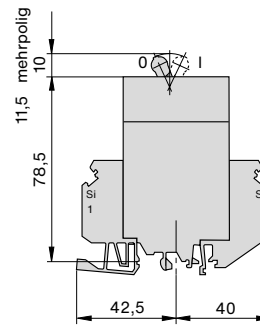

Technical data

Rated voltage	AC 250 V (50/60 Hz) DC 50 V (higher DC ratings upon request) UL: DC 75 V
Rated current	between 0.05 A ... 10 A
Breaking capacity I_{cn}	300 A
Ambient temperature	-30 ... +60 °C
For more information please visit	www.global.e-t-a.com/p72

2215 Dimensional drawing

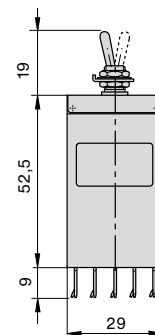

Technical data

Rated voltage	AC 240 V (50/60 Hz) / DC 50 V (single pole) / DC 80 V (double pole)
Rated current	between 0.5 A ... 16 A
Breaking capacity I_{cn}	Single pole: AC 240 V, 300 A / DC 32 V, 1 500 A / DC 50 V, 600 A Double pole: AC 240 V, 400 A / DC 32 V, 1 500 A / DC 80 V, 600 A
Ambient temperature	-30 ... +60 °C
For more information please visit	www.global.e-t-a.com/p3700

2216-S Dimensional drawing

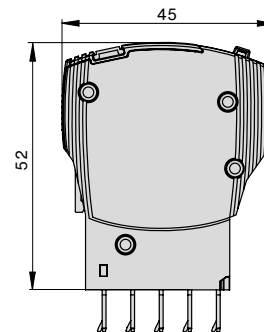

Technical data

Rated voltage	AC 240 V (50/60 Hz) / DC 50 V UL/CSA: AC 250 V
Rated current	between 0.1 A ... 16 A
Breaking capacity I_{cn}	single/double pole: AC 240 V 0.1 ... 2 A: 100 x I_N double pole: AC 240 V 2.5 ... 16 A: 300 A
Ambient temperature	-30 ... +60 °C
For more information please visit	www.global.e-t-a.com/p6455

3120-N-...M1 Dimensional drawing

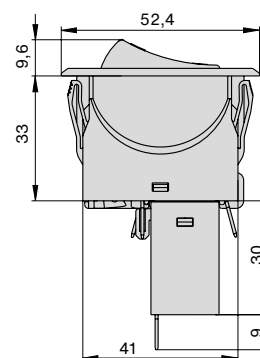

Circuit breakers and circuit protectors

3300/3400/3600/3900



3300

3600

Description

Single pole, thermal-magnetic circuit breakers, options include manual release button, auxiliary contacts or intermediate position Independent trip-free and snap action mechanisms ensure a reliable switching behaviour. You can choose between different mounting methods, such as plug-in type versions with blade terminals (3600) or threadneck mounting (3300/3400). Its low internal resistance makes the 3900 particularly suitable for low voltage applications.

Typical applications:

- Plant engineering
- Process control
- Power engineering

4230-T



Description

Single pole and multipole thermal-magnetic miniature circuit breakers (MCBs) in accordance with EN 60947-2, UL 1077 and UL 489 for DIN rail mounting, with toggle actuation, visual status indication and high rupture capacity. Reliable switching behaviour through snap-action and positively trip-free mechanisms. A range of trip characteristics and add-on modules allow a great variety of applications.

Typical applications:

- Plant engineering
- Machine building industry
- Power engineering
- Process control



Technical data

Rated voltage	AC 240 V (50/60 Hz) DC 65 V
Rated current	between 0.05 A ... 16 A
Breaking capacity I_{cn}	0.05 ... 0.8 A: self-limiting 1 ... 2 A: 200 A 2.5 ... 16 A: 400 A
Ambient temperature	-30 ... +60 °C
For more information please visit	www.global.e-t-a.com/c625

3600 Dimensional drawing example

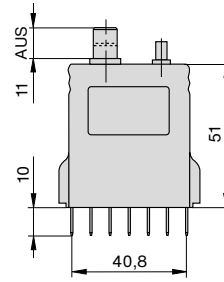

Technical data

Rated voltage	AC 480/277V; UL DC 60V; IEC DC 80V
Rated current	between 1 A ... 63 A
Breaking capacity I_{cs}/I_{cu}	to IEC/EN 60947-2 (Ics) DC 10,000 A to IEC/EN 60947-2 (Icu) AC/DC 10,000 A to UL 489 AC/DC 10,000 A
Ambient temperature	-35 ... +70 °C
For more information please visit	www.global.e-t-a.com/c625

4230-T Dimensional drawing

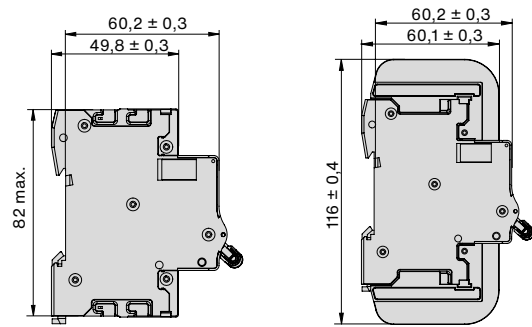



Find more information about magnetic and hydraulic-magnetic circuit breakers here: www.global.e-t-a.com/c624

808



Description

Single pole polarised circuit breaker with magnetic fast trip mechanism. An artless switching system ensures reliable disconnection even with the smallest overcurrents. Also suitable for impulse tripping. Compact design suitable for printed circuit board mounting. Low temperature sensitivity.

Typical applications:

- Power engineering
- Medical equipment
- Equipment control

8340-G2



Description

Single and multipole circuit breaker with magnetic or hydraulic-magnetic trip curve. Convenient threadneck panel or plug-in mounting, a range of trip characteristics and optionally with auxiliary contacts. ON/OFF switching through Push/Pull actuation. The precise switching mechanism ensures reliable disconnection through an independent trip-free mechanism even with the smallest overcurrents. Low temperature sensitivity at rated load.

Typical applications:

- Rail vehicles
- Agricultural machinery
- Construction machinery
- Specialty vehicles

MAGNETIC AND HYDRAULIC-MAGNETIC CIRCUIT BREAKERS

Fast protection – permanent safety

E-T-A's magnetic or hydraulic-magnetic circuit breakers have fast tripping curves. In the event of a short circuit, but even with small overloads, they disconnect the defective circuit almost without any delay through the magnetic trip mechanism or with an intended and defined delay through the hydraulic-magnetic trip. The individual data sheets provide all necessary details.

Characteristic features

- The trip element is the magnetic or hydraulic-magnetic system of the circuit breaker. Depending on this system, the trip current threshold can be higher or lower.
- Current peaks, e.g. caused by inrush currents, can cause nuisance tripping. Insensitivity against such current peaks can be achieved by selecting a model with a higher rated current. We will be happy to support you on the choice.

Temperature behaviour

- Independent of the ambient temperature at rated load.

Test certificates

- The magnetic or hydraulic-magnetic circuit breakers meet the specifications of the VDE and the EN 60934 (IEC 60934) standard for circuit breakers for equipment protection as well as many international and country-specific or user-specific standards. For detailed information please refer to the respective data sheet.

Optionally available:

- Auxiliary contacts: They offer various signalisation and alarm functions.
- Remote trip: This feature offers the option to physically disconnect the circuit via an impulse.
- Remote ON/OFF module: The circuit can be physically disconnected via an impulse and switched on again.

Technical data

Rated voltage	DC 24 V (other ratings upon request) UL/CSA: AC 120 V UL/CSA: DC 60 V
Rated current	between 0.01 A ... 5 A
Breaking capacity I_{cn}	100 A (o-o-o)
Ambient temperature	-30 ... +70 °C
For more information please visit	www.global.e-t-a.com/p83

808 Dimensional drawing

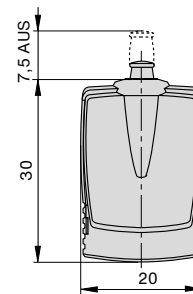

Technical data

Rated voltage	3 AC 415 V AC 240 V (50/60 Hz) DC 80 V UL/CSA: AC 250 V
Rated current	between 0.02 A ... 50 A 1-pole (40 + 50 A DC only) between 0.02 A ... 30 A multipole
Breaking capacity I_{cn}	$6 \times I_N$ at AC/ $4 \times I_N$ at DC
Ambient temperature	-40 ... +85 °C
For more information please visit	www.global.e-t-a.com/p84

8340-G2 Dimensional drawing

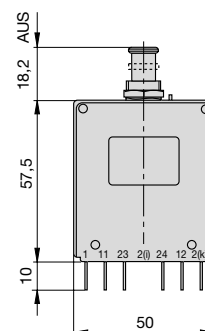

8340-F



Description

Single and multipole circuit breaker with magnetic or hydraulic-magnetic trip curve. Toggle actuation, front panel mounting, various trip characteristics and optionally available auxiliary contacts. The precise switching mechanism ensures reliable disconnection through an independent trip-free mechanism even with the smallest overcurrents. Low temperature sensitivity at rated load.

Typical applications:

- Telecommunications
- Datacom
- Rail vehicles

8340-T



Description

Single and multipole circuit breaker with magnetic or hydraulic-magnetic trip curve. Toggle actuation, rail mounting, various trip characteristics and optionally available auxiliary contacts. The precise switching mechanism ensures reliable disconnection through an independent trip-free mechanism even with the smallest overcurrents. Low temperature sensitivity at rated load.

Typical applications:

- Specialty vehicles
- Car production
- Machine building industry

8345



Description

Single and multipole circuit breaker with magnetic or hydraulic-magnetic trip curve. Toggle actuation, front panel mounting, various trip characteristics and optionally available auxiliary contacts. The precise switching mechanism ensures reliable disconnection through an independent trip-free mechanism even with the smallest overcurrents. Low temperature sensitivity at rated load. Add-on module for auxiliary contacts, remote trip or remote control are optionally available.

Typical applications:

- Telecommunications
- Datacom
- Rail vehicles
- Specialty vehicles



Technical data

Rated voltage	3 AC 415 V/AC 240 V (50/60 Hz) DC 80 V (higher DC ratings upon request) UL/CSA: 3 AC 250 V/AC 250 V
Rated current	between 0.02 A ... 50 A , 1-pole (40 + 50 A DC only) between 0.02 A ... 30 A multipole
Breaking capacity I_{cn}	$6 \times I_N$ at AC/4 $\times I_N$ at DC
Ambient temperature	-40 ... +85 °C
For more information please visit	www.global.e-t-a.com/p86

8340-F Dimensional drawing

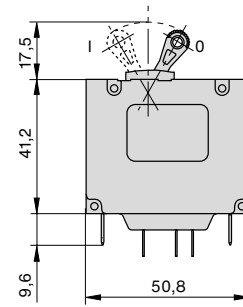

Technical data

Rated voltage	3 AC 415 V/AC 240 V (50/60 Hz) DC 80 V (higher DC ratings upon request) UL/CSA: 3 AC 250 V/AC 250 V
Rated current	between 0.02 A ... 50 A 1-pole (40 and 50 A only DC) between 0.02 A ... 30 A multipole
Breaking capacity I_{cn}	$6 \times I_N$ at AC/4 $\times I_N$ at DC
Ambient temperature	-40 ... +85 °C
For more information please visit	www.global.e-t-a.com/p87

8340-T Dimensional drawing

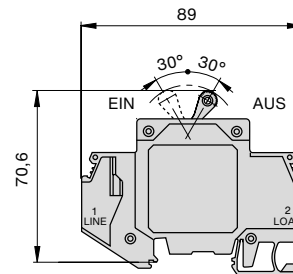

Technical data

Rated voltage	3 AC 415 V AC 277/480 V AC 120/240 V AC 240 V/DC 80 V
Rated current	between 0.05 A ... 125 A between 150 A ... 180 A 1-pole protected
Breaking capacity I_{cn}	10,000 A at DC/ 5 000 A at AC
Ambient temperature	-40 ... +85 °C
For more information please visit	www.global.e-t-a.com/p88

8345 Dimensional drawing

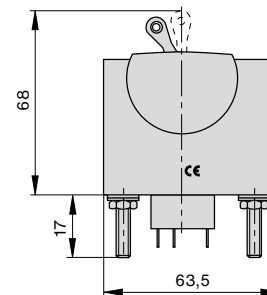



Information on high performance circuit breakers:
www.global.e-t-a.com/c623

410/520/530

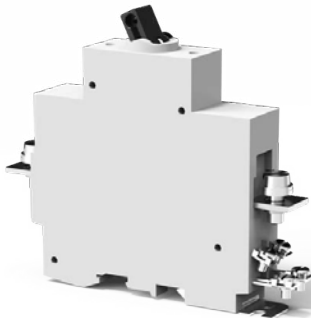

Description

Single pole (410 version), double pole (520 version) or three-pole (530 version) thermal-magnetic high performance circuit breakers according to EN 60947 for various mounting methods, with toggle actuation and high rupture capacity. Independent trip-free and snap action mechanisms ensure a reliable switching behaviour. A range of trip characteristics, auxiliary contacts and remote control options allow a great variety of applications.

Typical applications:

- Rail vehicles
- Construction machinery
- Specialty vehicles

412/413



Description

Single pole, thermal circuit breaker with threadneck mounting, push-pull actuation and high rupture capacity. Independent trip-free and snap action mechanisms ensure a reliable switching behaviour.

Typical applications:

- Rail vehicles
- Construction machinery
- Agricultural machinery
- Specialty vehicles
- Aerospace

HIGH PERFORMANCE CIRCUIT BREAKERS

Professional protection – unrivalled performance

E-T-A high performance circuit breakers feature thermal or thermal-magnetic trip characteristics with an extremely high rupture capacity.

The thermal element of the circuit breakers provides protection in the event of an overload with a delayed trip characteristic. The magnetic element responds without time delay to high overload and short circuit currents. It disconnects the faulty circuit within a few milliseconds.

Characteristic features

- Powerful snap action mechanism whose components connect the power system with the contact system to ensure reliable ON and OFF switching in the event of an overload.

- The devices have a positively trip-free mechanism. Protective function is independent of external influences even if the push button or operating toggle is blocked.
- All devices are tracking resistant and flame retardant.
- Some modules are optionally available with auxiliary contacts. They offer various signalisation and alerting functions.

High performance circuit breakers are the ideal alternative to MCBs in measuring and control equipment, in vehicles (rail, road, water) and in aerospace technology (on the ground and air-borne).

Technical data

Rated voltage	AC 240 V/3 AC 415 V DC 110 V
Rated current	between 10 A ... 125 A (EN 60947) between 7 A ... 100 A (EN 60898)
Breaking capacity I_{cn}	AC 240 V: 6,000 A: DC 110 V: 5,000 A:
Ambient temperature	-40 ... +60 °C
For more information please visit	www.global.e-t-a.com/c623

410 Dimensional drawing example

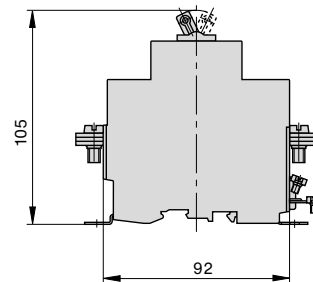

Technical data

Rated voltage	DC 28 V AC 115 V (400 Hz) upon request
Rated current	between 6 A ... 25 A (-FN) between 7.5 A ... 35 A (-LN/-N) Smaller ratings upon request.
Breaking capacity I_{cn}	DC 28 V: 6,000 A:
Ambient temperature	-55 ... +75 °C
For more information please visit	www.global.e-t-a.com/c623

412 Dimensional drawing example

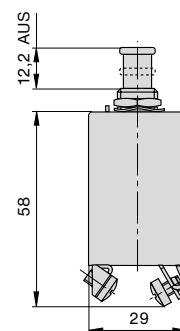

437

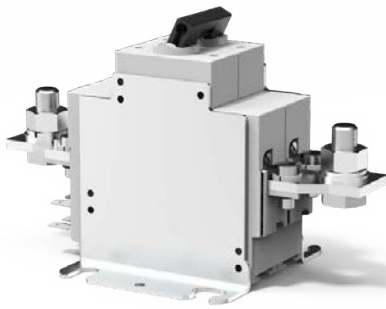

Description

Single pole, thermal-magnetic circuit breaker with toggle actuation and high rupture capacity. Independent trip-free and snap action mechanisms ensure a reliable switching behaviour. Various housing versions, trip characteristics, auxiliary contacts and remote control option allow a wealth of applications.

Typical applications:

- Rail vehicles
- Specialty vehicles

446/447/449



Description

Single pole, thermal-magnetic high performance circuit breakers with socket mounting, manual release button, high rupture capacity and optionally auxiliary contacts and/or remote trip. Independent trip-free and snap action mechanisms ensure a reliable switching behaviour.

Typical applications:

- Construction machinery
- Specialty vehicles

452

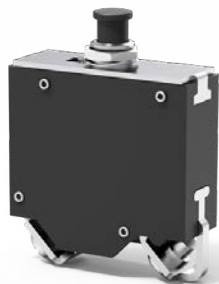

Description

Single pole, thermal-magnetic circuit breaker with threadneck mounting, push-pull operation, high rupture capacity and auxiliary contacts as an option. Independent trip-free and snap action mechanisms ensure a reliable switching behaviour.

Typical applications:

- Construction machinery
- Agricultural machinery
- Specialty vehicles
- Aerospace

482



Description

Single pole, thermal circuit breaker with threadneck mounting, push-pull actuation, high rupture capacity and auxiliary contacts as an option. Independent trip-free and snap action mechanisms ensure a reliable switching behaviour.

Typical applications:

- Construction machinery
- Agricultural machinery
- Specialty vehicles
- Aerospace



Technical data

Rated voltage	DC 144 V higher ratings upon request
Rated current	between 40 A ... 240 A higher ratings upon request
Breaking capacity I_{cn}	DC 180 V: 2,000 A, L/R = 0 ms DC 28 V: 10,000 A, L/R = 0 ms DC 28 V: 7,500 A, L/R = 13 ms
Ambient temperature	-40 ... +60 °C
For more information please visit	www.global.e-t-a.com/p93

437 Dimensional drawing

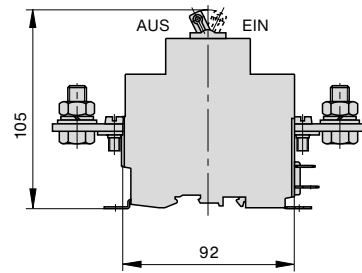

Technical data

Rated voltage	DC 28 V
Rated current	between 30 A ... 400 A: 446 circuit breaker between 100 A ... 400 A: 447 circuit breaker between 125 A ... 500 A: 449 circuit breaker
Breaking capacity I_{cn}	10,000 A:
Ambient temperature	-55 ... +75 °C
For more information please visit	www.global.e-t-a.com/c623

446 Dimensional drawing example

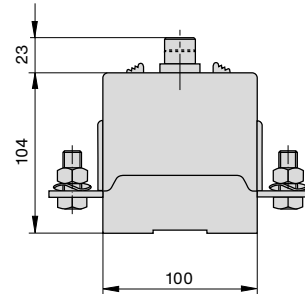

Technical data

Rated voltage	DC 28 V (UL: DC 72 V)
Rated current	between 50 A ... 100 A
Breaking capacity I_{cn}	6,000 A:
Ambient temperature	-55 ... +75 °C
For more information please visit	www.global.e-t-a.com/p95

452 Dimensional drawing

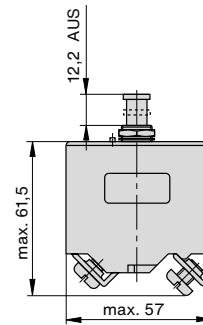

Technical data

Rated voltage	AC 115 V (400 Hz) DC 28 V AC 230 V (50/60 Hz) upon request
Rated current	between 0.1 A ... 50 A
Breaking capacity I_{cn}	0.1 ... 2.5 A: 15 x I_N 3 ... 3.5 A: 250 A DC/150 A AC 4 ... 7 A: 500 A 7.5 ... 50 A: 6,000 A DC/1,000 A AC
Ambient temperature	-55 ... +75 °C
For more information please visit	www.global.e-t-a.com/p96

482 Dimensional drawing

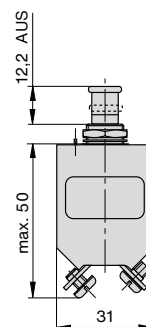

483/583

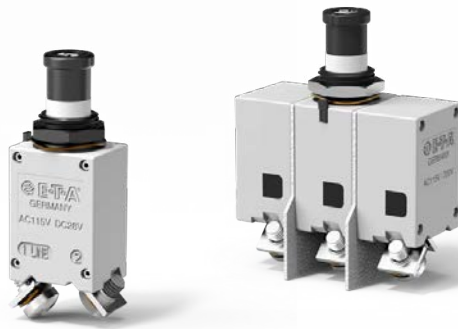

Description

Single pole or three-pole thermal circuit breaker with threadneck mounting, push-pull operation, temperature compensation, high rupture capacity and optional auxiliary contacts. Independent trip-free and snap action mechanisms ensure a reliable switching behaviour. The special design ensures suitability for the most demanding applications.

Typical applications:

- Aerospace

4120



Description

Single pole, thermal circuit breaker with threadneck mounting, push-pull operation, temperature compensation, high rupture capacity and optional auxiliary contacts. Reliable switching behaviour through trip-free mechanism. The special design ensures suitability for the most demanding applications.

Typical applications:

- Aerospace

4140/5140

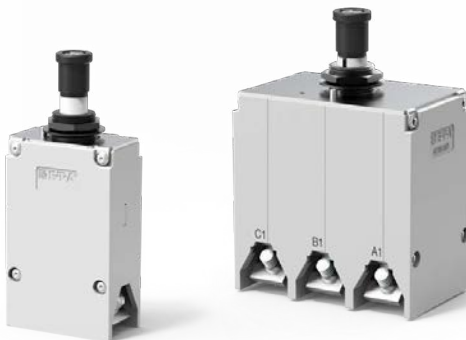

Description

Single pole or three-pole thermal circuit breaker with threadneck mounting, push-pull operation, temperature compensation, high rupture capacity and optional auxiliary contacts. Reliable switching behaviour through trip-free mechanism. The special design ensures suitability for the most demanding applications.

Typical applications:

- Aerospace

9510



Description

Single pole, magnetic control switch with threadneck or flange mounting push-pull actuation and extremely low trip current. Push button marking either with marking insert (pluggable and exchangeable) or with adhesive labels. Blade terminals, screw terminals or wire wrap terminals

Typical applications:

- Aerospace (simulators)



Technical data

Rated voltage	AC 115 V (400 Hz) (483) 3 AC 200 V (400 Hz)/DC 28 V (583)
Rated current	between 1 A ... 35 A (483) between 1 A ... 30 A (583)
Breaking capacity I_{cn}	AC 115 V (400 Hz): ≤ 4 A: 1,000 A/ 5 A: 2,000 A/7.5 ... 35 A: 2,500 A/ DC 28 V: 1 ... 25 A: 6,000 A/ 30+ 35 A: 4,000 A:
Ambient temperature	-55 ... +125 °C
For more information please visit	www.global.e-t-a.com/c623

483 Dimensional drawing example

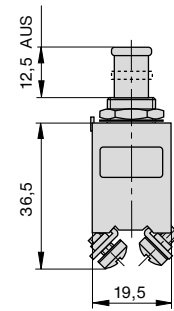

Technical data

Rated voltage	AC 115 V (400 Hz) DC 28 V
Rated current	between 1 A ... 25 A
Breaking capacity I_{cn}	AC 115 V (400 Hz): 1 ... 4 A: 1,000 A/ 5... 25 A: 2,000 A: DC 28 V: 1 ... 25 A: 6,000 A:
Ambient temperature	-55 ... +125 °C
For more information please visit	www.global.e-t-a.com/p98

4120 Dimensional drawing

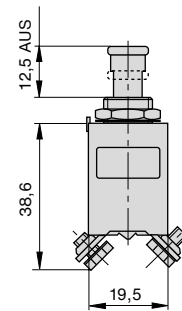

Technical data

Rated voltage	AC 115 V (400 Hz) DC 28 V
Rated current	between 20 A ... 50 A
Breaking capacity I_{cn}	AC 115 V (400 Hz): 1,500 A (4140) DC 28 V: 4,000 A (4140) AC 200 V (400 Hz): 2,000 A (5140)
Ambient temperature	-55 ... +125 °C
For more information please visit	www.global.e-t-a.com/p99 www.global.e-t-a.com/p101

4140 Dimensional drawing

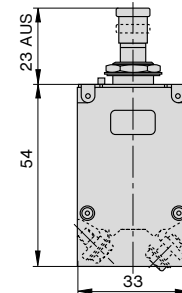

Technical data

Rated voltage	DC 24 V DC 28 V
Rated current	between 0.5 ... 150 A
Ambient temperature	-30 ... +60 °C
For more information please visit	www.global.e-t-a.com/p106

9510 Dimensional drawing

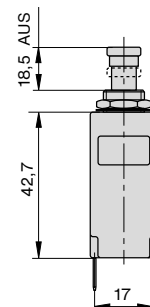



Find more information about power entry modules here: www.global.e-t-a.com/c18870

X3120/X3130

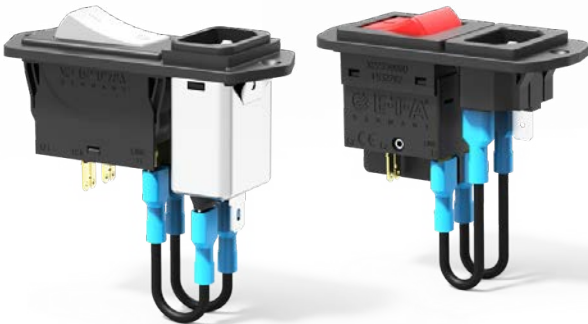

Description

The X3120 A/B combines up to 5 functions space-saving within a single component: C14/C20 appliance inlet, ON/OFF switch, resettable overcurrent protection, line filter and optionally undervoltage release/remote release /auxiliary switch.

The X3130 combines three functions within a single component: C14 appliance inlet, rocker switch and resettable overcurrent protection.

Typical applications:

- Medical equipment
- Laboratory equipment
- professional audio devices
- 3D printers

XR38



Description

The XR38 power entry module for 3/8 threadneck circuit breakers (e.g. 106 or 2-5700) combines up to three functions within a single component: a C14 appliance inlet, a resettable overcurrent protection and a line filter.

Typical applications:

- Medical equipment
- Laboratory equipment
- Professional kitchen tools
- 3D printers

POWER ENTRY MODULES

with integral circuit breakers

Systematic reduction of components is a key success factor for a cost-saving design. Many products Less components increase the overall reliability and additional space-savings.

Characteristic features

- **Resettable circuit breaker:** The XR38 power entry modules combine a C14 appliance inlet and a single or double pole E-T-A resettable circuit breaker within a single component. These modules are highly recommendable for applications where the ON/OFF switch (power switch) cannot be mounted in close proximity to the power entry module.
- **Circuit breaker/switch combinations:** The 3120/3130 overcurrent circuit breaker also serves as an ON/OFF switch for equipment and machinery. For the actuator,

you can choose between rocker switches in many different colours and with different markings, even with illumination upon request.

- **Circuit breakers and line filters** The X3120 and XR38 power entry modules are optionally available with line filters. Standard versions for general industrial applications are available as well as medical line filters without Y-capacitors.

Test certificates

The power entry module components are certified according to the specifications of the VDE, TÜV, UL and CSA. For detailed information please see the individual data sheets.

Technical data

Rated voltage	AC 250 V
Rated current	X3120-A with C14: 10 A (IEC/EN) X3120-B with C20: 16 A (IEC/EN) X3130 with C14: 10 A (IEC/EN)
Ambient temperature	-30 ... +60 °C (X3120) -25 ... +70 °C (X3130)
For more information please visit	www.global.e-t-a.com/p6699 (X3120) www.global.e-t-a.com/p6700 (X3130)

Technical data

Rated voltage	AC 250 V
Rated current	10 A (IEC/EN)
Ambient temperature	-25 ... +60 °C
For more information please visit	www.global.e-t-a.com/p6701

X3120-B Dimensional drawing example

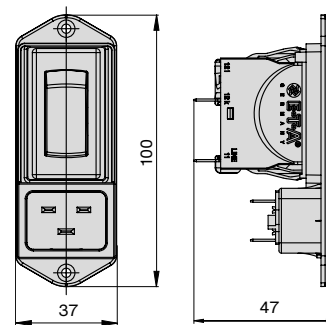

XR38/Type 106/Line filter Dimensional drawing

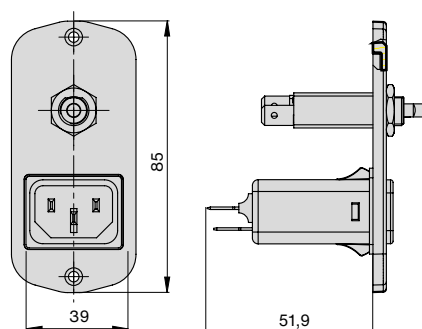

DC AND AC ELECTRONIC OVER-CURRENT PROTECTION

Reliable protecting, switching and monitoring



Electronic circuit protectors and electronic circuit breakers

Electronic circuit protector are purely electronic overcurrent protection devices. Electronic circuit breakers, however, offer mechanical disconnection in addition to the electronic trip, i.e. genuine physical isolation (bimetal).

Electronic DC overcurrent protection

Applications

Electronic overcurrent protection by means of electronic circuit protectors and circuit breakers is ideally suitable for the selective protection of system components in industrial plants and their supply lines, which are powered by DC switch mode power supplies.

Technology

The electronic overcurrent protection prevents voltage dips in the output voltage of switch mode power supplies both in the event of short circuits or overloads. These products also ensure selective protection or disconnection. Switching on loads with high input capacities as well as signalling an error in the system is easily possible. Errors are indicated by means of LEDs and auxiliary contacts. This enables targeted trouble-shooting and increases machine uptime.

Electronic overcurrent protection AC

Applications

Electronic overcurrent protection by means of electronic AC circuit breakers is ideally suitable for the selective protection of uninterruptible power supplies (UPS) in industrial plants. These solutions ensure true power safety through AC UPS systems.

Technology

In the event of a short circuit or an overload, the electronic overcurrent protection provided by electronic AC circuit breakers prevents a disconnection of the entire output voltage of the UPS systems. At the same time these products ensure selective protection or disconnection even under very unfavourable load conditions, as the devices react faster than the UPS itself to the overload condition. Besides the selective protection, these devices offer a very high overall savings potential.



Find more information about DC electronic overcurrent protection here: www.global.e-t-a.com/c604

ESS22-T



Description

The ESS22-T double pole, electronic circuit breaker allows individual integration into a plant concept of ungrounded power supply networks in the DC 24 V range. It is only 22.5 mm wide and only 90 mm high and deep and is therefore the ideal solution for compact control cabinets. The selective load protection of the ESS22-T provides double pole physical isolation of only the defective path in the event of an overload or a short circuit.

Typical applications:

- Plant engineering
- Process control

ESS30-S



Description

The ESS30-S electronic circuit breaker with physical isolation is a "low energy breaker" for DC 24 V applications and available both with fixed and adjustable current ratings. It is approved according to VDE EN/EC 60934 and UL1077 as a circuit breaker for equipment protection and therefore perfectly suitable for the use in centralised and decentralised power supply units.

Typical applications:

- Plant engineering
- Process control
- Power engineering

ESS31-T



Description

The ESS31-T electronic circuit breaker offers actual physical isolation. After a manual disconnection or a trip, the physical isolation will effectively prevent any return supply to the DC 24 V control voltage. The ESS31-T switches off the overload current at 1.2 times the rated current within 500 ms, and even within 100 ms in the event of a short circuit.

Typical applications:

- Machine building industry
- Plant engineering

ESX10/ESX10-S



Description

The ESX10 and ESX10-S provide individual load protection against overload and short circuit and electronically and selectively disconnect the load in the event of a failure. The ESX10 is available with fixed current ratings from 0.5 A to 16 A. The ESX10-S is available with adjustable current ratings between 1 A - 10 A, adjustable in 1 A increments. Both devices are pluggable and compatible with the 17plus and 18plus power distribution modules.

Typical applications:

- Machine building industry
- Plant engineering
- Process control

ESX10-T/ESX10-T 48 V/ESX10-TD



Description

The ESX10-T version offers overcurrent protection for DIN rail mounting. It is only 12.5mm wide and provides selective protection for all DC 12 V, DC 24 V and DC 48 V load circuits. This is realised by a combination of active, electronic current limitation in the event of a short circuit and an overload disconnection at $1.1 \times I_n$ times. The ESX10-T protects all kinds of loads with a single trip curve.

Typical applications:

- Machine building industry
- Plant engineering
- Process control

REF16-S



Description

The REF16-S selective load protection exclusively disconnects the faulty path in the event of an overload or a short circuit in the load circuit without affecting the DC 24 V supply. If there is an error in only one load circuit, a voltage dip will be reliably compensated and the disconnection of all loads connected to the switch mode power supply is prevented. The REF16-S limits the short circuit current to typically 1.25 times the rated current and disconnects the faulty circuit after 800 ms at the latest.

Typical applications:

- Machine building industry
- Plant engineering



Technical data

Rated voltage	DC 24 V
Rated current	0.5 A, 1 A, 2 A, 3 A, 3.6 A, 4 A, 6 A, 8 A, 10 A, 12 A
Current limitation	typically $1.2 \times I_N$
Ambient temperature	0 ... +50 °C
For more information please visit	www.global.e-t-a.com/p4152

Dimensions of ESS31-T

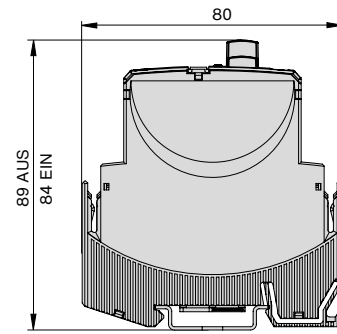

Technical data

Rated voltage	DC 24 V
Rated current	0.5 A, 1 A, 2 A, 3 A, 4 A, 6 A, 8 A, 10 A, 12 A, 16 A Adjustable current ratings: 1-10 A in 1 A steps
Current limitation	typ. $1.8/1.5/1.3 \times I_N$ typ. $1.4 \times I_N / 2.5$
Ambient temperature	0 ... +50 °C
For more information please visit	ESX10: www.global.e-t-a.com/p1034 ESX10-S: www.global.e-t-a.com/p4143

Dimensions example ESX10-S

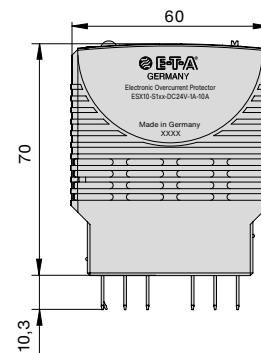

Technical data

Rated voltage	DC 12 V/DC 24 V/DC 48 V
Rated current	0.5 A, 1 A, 2 A, 3 A, 4 A, 6 A, 8 A, 10 A, 12 A, 16 A, 20 A, 25 A adjustable: 0.5/1/2 A, 2/3/4 A, 2/4/6 A, 6/8/10 A
Current limitation	typ. $1.8/1.5/1.3/1.4 \times I_N$
Ambient temperature	-25 ... +60 °C
For more information please visit	www.global.e-t-a.com/p4144

Dimensions example ESX10-T

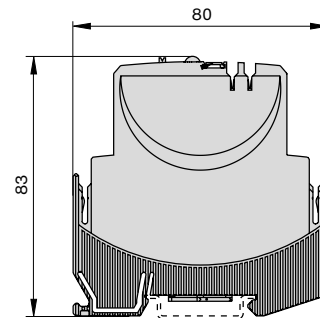

Technical data

Rated voltage	DC 24 V
Rated current	0.09 A, 0.5 A, 1 A, 2 A, 3 A, 4 A, 6 A, 8 A, 10 A
Current limitation	typically $1.25 \times I_N$
Ambient temperature	-25 ... +50 °C
For more information please visit	www.global.e-t-a.com/p3706

Dimensions REF16-S

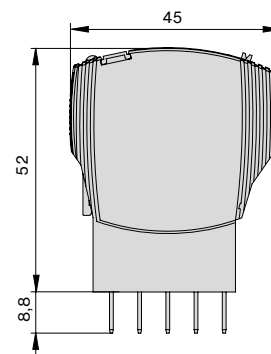

EM12-T



Description

The EM12 supply modules for the power input of the REX system are available in different versions, providing true flexibility with regard to costs and functionalities.

Typical applications:

- Machine building industry

PM12-T



Description

The PM12-T power distribution concept of the REX system can very easily be divided into two main groups. In the same system, the user can easily realise not only the + DC 24 V distribution, but also the minus - distribution 0 V (GND).

Typical applications:

- Machine building industry

REX12-T



Description

The REX12 electronic circuit protector combines flexibility and compactness - whether single or double pole. Our REX12 is a space-saving and reliable protection, tailor-made for primary pulsed DC 24 V switch mode power supplies. The one-channel circuit protector is available in all standard fixed rated currents from 1 A to 10 A. The double-channel devices are available with fixed rated currents of 1 A, 2 A, 3 A, 4 A and 6 A and with adjustable rated currents between 1 A to 10 A or 1 A to 4 A.

Typical applications:

- Machine building industry

REX22D



Description

The new REX22D completes the REX system and combines a trip curve with situated, active, linear current limitation with the typical slim design. It allows effective protection of all DC 24 V switch mode power supply applications with low overload capacity and for trip curves designed for DC 24 V drive technology.

Typical applications:

- Machine building industry
- Car production
- Automation



Technical data

Rated voltage	DC 24 V (18 ... 30 V)
Rated current	max. 40 A
Ambient temperature	-30 ... +60 °C
For more information please visit	www.global.e-t-a.com/p4473

EM12-T Dimensional drawing

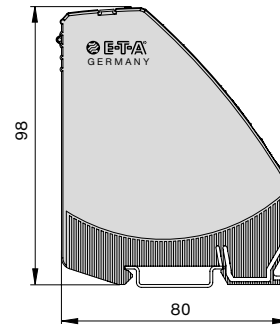

Technical data

Rated voltage	DC 24 V (18 ... 30 V)
Rated current	max. 20 A
Ambient temperature	-30 ... +60 °C
For more information please visit	www.global.e-t-a.com/p4473

PM12-T Dimensional drawing

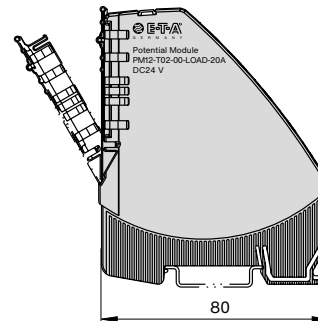

Technical data

Rated voltage	DC 24 V (18 ... 30 V)
Rated current	Single-channel: 1 A, 2 A, 3 A, 4 A, 6 A, 8 A, 10 A Double-channel: 1 A/1 A, 2 A/2 A, 3 A/3 A, 4 A/4 A, 6 A/6 A Double-channel: 1 A...4 A, 1 A ... 10 A
Current limitation	Time-current characteristics (REX12-T)
Ambient temperature	-25 ... +60 °C
For more information please visit	www.global.e-t-a.com/p4473

REX12-T Dimensional drawing

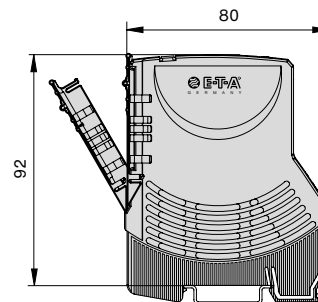

Technical data

Rated voltage	DC 24 V (18 ... 32 V)
Rated current	1 A ... 20 A fixed or adjustable
Load circuit disconnection	Overload disconnection (I_{UL}) typ. 3s Short circuit disconnection (I_{KS}) typ. 0.01 to 1s
Ambient temperature	-30 ... +60 °C
For more information please visit	www.global.e-t-a.com/p6696

REX22D Dimensional drawing

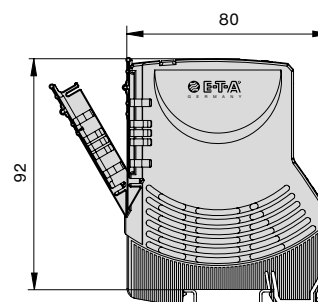



Find more information about AC electronic overcurrent protection here: www.global.e-t-a.com/c16133

EBU



Description

The EBU10-T hybrid circuit breaker is specifically designed for the protection of AC UPS systems. The unit effectively ensures stable operation and therefore a truly reliable power supply. The circuit breaker consists of an MCB and an add-on electronic circuitry, which takes over measuring and evaluation tasks. The device can be adjusted to the capabilities of the used UPS. In the event of a failure the circuit breaker will disconnect only the faulty path.

Typical applications:

- Plant engineering
- Process control

ELECTRONIC OVERCURRENT PROTECTION AC

Reliable power supply for UPS operation

The mechatronic EBU10-T circuit breaker provides selective overcurrent protection for UPS systems with AC 230 V. The unit consists of an MCB approved for short circuit interruptions up to 10 kA. The second element is an add-on electronic circuitry for measuring and evaluation tasks. The product is available with rated currents of 4 A, 6 A, 10 A and 16 A, with B and C characteristics, and is directly operated at the output of the respective UPS.

Uninterruptible power supplies only provide a limited current in the event of a short circuit. The current provided by the UPS is not sufficient to trip a thermal-magnetic overcurrent circuit breaker. This means, that in the event of a failure, the entire UPS system will be switched off. The EBU10-T can be adjusted to the capability of the respective UPS unit and the actual load conditions via two

selection switches, which ensures that the device will trip reliably, but only the defective load path. All other supply lines will remain unaffected. The unit tolerates switch-on operations and the corresponding high inrush currents.

Your benefits

- Increased system availability through effective protection
- Reduced overall costs through a 1/3 more effective design
- Facilitated planning through adjustable overcurrent protection

Technical data

Rated voltage	AC 230 V
Rated current	4 A, 6 A, 10 A, 16 A
Breaking capacity I_{cn}	2 cycles (O-CO); U_N (AC); 10,000 A; $\cos \phi = 0.5$
Ambient temperature	-35 ... +60 °C
For more information please visit	www.global.e-t-a.com/p4475

EBU Dimensional drawing

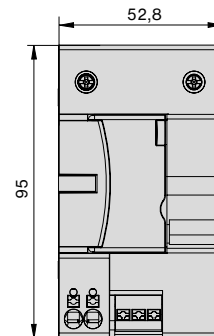

RELAYS

Versatile use for
fast and reliable switching

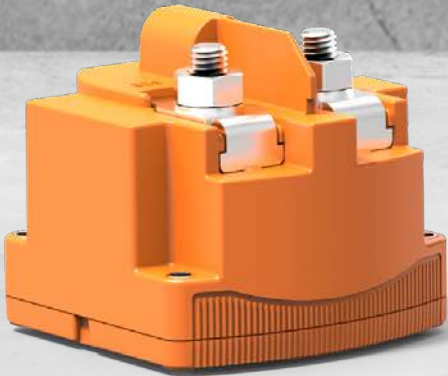

Solid state relays

Applications

Solid state relays are suitable for continuous currents up to 50 A. They are used in any application where mechanical relays would quickly reach their limits.

Technology

Solid state relays combine high-end power semi-conductors with comprehensive know-how in the areas of heat management, EMC-compliant design and overcurrent protection.

Timer relays

Applications

Timer relays control pumps, valves or motors which are meant to overtravel or stay open for a defined period of time. They also control the coordinated, sequential on-switching of loads to avoid load peaks.

Technology

E-T-A timer relays combine a well-proven mechanical contact system with the flexibility of an electronic counting mechanism. As a replacement for standard automotive relays, you can implement ON or OFF delay or both.

Special relays

Applications

The EXR10 is suitable for buses, trucks and construction machinery where it prevents a discharging of the vehicle battery. As soon as a voltage falls below a defined value, the load is automatically disconnected.

Technology

The integral microcontroller allows customer-specific programming and provides many additional functions. The relay configurator on our homepage will help you find the right solution.

Power relays

Applications

Power relays switch high currents. High electrical loads can be found especially in construction machinery and agriculture vehicles, as well as in buses, trucks, industrial trucks and other specialty vehicles. In these applications, power relays disconnect the entire on-board electrical system from the battery.

Technology

Depending on the application, E-T-A offers purely electro-mechanical relays, solid state relays and also a hybrid design consisting of an electro-mechanical switching system with an intelligent electronic control unit.

High voltage relays

Applications

The HVR10 high voltage relay is the right solution for electrified power trains in buses, construction machinery and specialty vehicles. Thanks to its high performance it is also suitable for charging stations, energy storages and as main relay in vehicles.

Technology

The HVR10 is a powerful hybrid high voltage relay in a compact design. It combines physical isolation of high voltages via an electro-mechanical contact and state-of-the-art semi-conductor technology.

Relay configurator

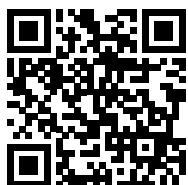



Find more information about solid state relays here: www.global.e-t-a.com/c16575

ESR10



Description

As a replacement for standard automotive relays, the ESR10 is used wherever loads need to be switched frequently, e.g. for controlling pumps, valves, lights or fans.

Typical applications:

- Construction machinery
- Forestry equipment and agricultural vehicles
- Boats
- Passenger cars
- Buses and trucks
- Specialty vehicles

SOLID STATE RELAYS

Durable, robust, silent.

The electronic solid state relay portfolio is used in all applications where mechanical relays soon reach their limits. They can be switched more frequently, more silent and faster than mechanical relays and are suitable for the use in buses and trucks, agricultural and forestry equipment, specialty vehicles and passenger cars.

Technology

Solid state relays combine high-end power semi-conductors with comprehensive know-how in the areas of heat management, EMC-compliant design and overcurrent protection. The electronics guarantee wear-free, silent and extremely fast switching for the entire typical life.

Your benefits:

- Reliable functioning for the entire vehicle lifetime through wear-free switching
- Flexible use of the devices through extraordinary robustness against environmental influences such as dust, humidity and vibration
- Maximum comfort for the driver through silent switching

Technical data

Rated voltage	DC 12 V/DC 24 V
Rated current	10 A, 17 A, 30 A
Design	Cubic: 22.8 x 15.4 x 26 mm
Ambient temperature	-40 ... +85 °C
For more information please visit	www.global.e-t-a.com/p4388

ESR10 Dimensional drawing

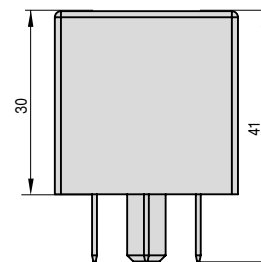



Find more information about timer relays here: www.global.e-t-a.com/c17381

ETR10



Description

The ETR10 combines the timer relay function with overcurrent protection in a single component, minimising the number of connections in the circuit and reducing the failure risk. If an overload in the load path has led to an off-switching of the device, the ETR10 can be remotely switched on again.

Typical applications:

- Buses and trucks
- Construction machinery
- Specialty vehicles
- Passenger cars
- Rail vehicles
- Boats
- Agricultural vehicles and forestry equipment

TIMER RELAYS

Flexible, time-saving, cost-saving.

Timer relays are suitable for the use in passenger cars, trucks, buses as well as construction machinery, agricultural machinery and specialty vehicles. They control pumps, valves or motors, which are meant to overtravel or stay open for a defined period of time. They also control the coordinated, sequential on-switching of loads to avoid load peaks (e.g. with fans). E-T-A timer relays are available for DC 12 V and DC 24 V applications and are suitable for standard car relay sockets according to ISO 7588.

Technology

The ETR10 provides all benefits of an electronic contact system and the flexibility of an integral micro controller.

Your benefits:

- Reduced complexity through a customer-specific software that can be perfectly adapted to the customer applications.
- Direct replacement of standard relays through intelligent relays with additional functions
- Long typical life due to a fully electronic contact system

Technical data

Rated voltage	DC 12/DC 24 V
Rated current	10 A/30 A
Design	Cubic: 30 x 30 x 40 mm
Ambient temperature	-40 ... +85 °C
Contact system	electronic
For more information please visit	www.global.e-t-a.com/p4386

ETR10 Dimensional drawing

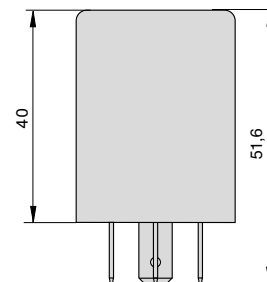



Find more information about special relays here: www.global.e-t-a.com/c17416

EXR10



Description

The EXR10 special electronic relay combines low voltage detection and many different special functions in a single device: diagnostic, time, relay and fuse function. You can use the configurator on our homepage to adapt all EXR10 main functions, such as overcurrent protection, to your specific requirements.

Typical applications:

- Construction machinery
- Agricultural and forestry equipment
- Specialty vehicles
- Passenger cars
- Buses
- Trucks
- Boats

SPECIAL RELAYS

Durable, versatile, robust.

The EXR10 is suitable for buses, trucks and construction machinery where it prevents a discharging of the vehicle battery. As soon as a voltage falls below a defined value, the load is automatically disconnected.

Technology

The integral microcontroller allows customer-specific programming and provides many additional functions. The relay configurator on our homepage will help you find the right solution.

Your benefits

- Increased vehicle operational readiness through reduced maintenance thanks to wear-free switching
- Extremely robust and resistant to environmental influences
- Individually adjustable thanks to the online configurator

Relay configurator:

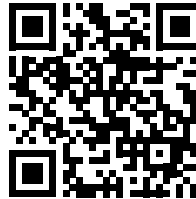

Technical data

Rated voltage	DC 12 V/DC 24 V
Rated current	1 A ... 30 A
Design	cubic
Contact system	electronic
Ambient temperature	-40 ... +85 °C
For more information please visit	www.global.e-t-a.com/p6437

EXR10 Dimensional drawing

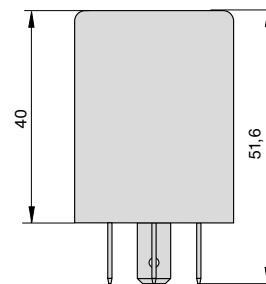



Find more information about power relays here: www.global.e-t-a.com/c16577

MPR10/MPR20



Description

The MPR10 is a bistable power relays, i.e. a short current impulse is required only for the switching operation. The contact is held in its position by permanent magnets without using current. The MPR20 is a monostable power relay. It immediately switches to its original state if the power supply is interrupted, which is considered an additional safety factor.

Typical applications:

- Buses
- Specialty vehicles
- Agricultural vehicles and forestry equipment
- Trucks
- Construction machinery

HPR10



Description

The HPR10 is a hybrid power relay. By combining an electro-mechanical switching system with the intelligence of a microcontroller in the same unit, E-T-A offers the smartest power relay on the market. The HPR10 main functions, e.g. the overcurrent protection, can be customer-specifically designed with our configurator.

Typical applications:

- Buses
- Specialty vehicles
- Agricultural vehicles and forestry equipment
- Trucks
- Construction machinery

POWER RELAYS

No maintenance despite high currents.

Power relays were designed for switching high current loads and for disconnecting the battery from the on-board electrical system. The MPR10, MPR20 and HPR10 single pole power relays have an electro-mechanical switching system and are available with various mounting methods. Corresponding to their protection class, the relays are protected against water ingress and dust. Therefore, they are the perfect choice for demanding applications in utility vehicles.

The MPR10 power relay is a bistable relay. It only requires a short current pulse for the switching operation. Permanent magnets then keep the contact in the respective position.

The MPR20 is a monostable high current relay. It immediately switches to its original state if the power supply is interrupted. The fully integral power saving electronics reduce power consumption to less than 2 W.

The HPR10 is a hybrid power relay. It includes an electro-mechanical relay and its own electronic control unit. This electronic circuitry can be level- or edge-controlled

and manages the intelligent activation of the bistable electro-mechanical switching mechanism, an additional timer control (ON or OFF delay) and other configurable functions. All power relay versions are available for DC 12 V, DC 24 V and 48 V voltage levels.

The EPR10 is a solid state relay for high continuous currents (75 A to 200 A) and a reliable alternative for mechanical relays. The EPR10 requires up to 80 % less space than conventional solid state relays because it does not need a heat sink. The low holding current and the low internal resistance reduce power and thermal losses. The remaining heat is dissipated via the connecting cables. The reduced energy consumption also minimises CO₂ emissions.

The relay is practically maintenance-free and has a very long typical life compared to conventional mechanical relays. Optionally available functions such as overcurrent protection help further reduce system costs.

Technical data

Rated voltage	DC 12 V/DC 24 V/DC 48 V
Rated current	100 A, 200 A, 300 A
Terminal options	M8 or M10 stud M4 or HDSCS connector
Ambient temperature	-40 ... +85 °C
For more information please visit	MPR10: www.global.e-t-a.com/p4417 MPR20: www.global.e-t-a.com/p6580

Technical data

Rated voltage	DC 12 V/DC 24 V
Rated current	100 A, 200 A, 300 A
Terminal options	M8 or M10 stud M4 or HDSCS connector
Ambient temperature	-40 ... +85 °C
For more information please visit	www.global.e-t-a.com/p4741

MPR10/MPR20 Dimensional drawing

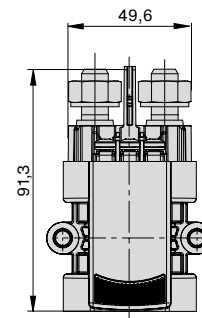

HPR10 Dimensional drawing

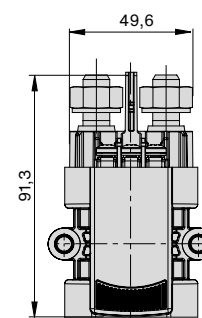

Relays

EPR10



Description

The EPR10 electronic power relay is a solid state relay for high continuous currents. This relay is widely used in utility and specialty vehicles, where reliability and functional safety are indispensable. At DC 24 V, the EPR10 allows a continuous load of up to 200 A. Two versions are available: with (EPR10-P) and without protective function (EPR10-N). Two performance classes are available for EPR10-N (up to 100 A and up to 200 A).

Typical applications:

- Construction machinery
- Agricultural machinery
- Specialty vehicles



Find more information about power relays here: www.global.e-t-a.com/c16577

Technical data

Rated voltage	DC 12 V/DC 24 V
Rated current	EPR10-P (with protective function) 75 A, 100 A, 125 A, 150 A, 175 A, 200 A
Ambient temperature	-40 ... +85 °C
For more information please visit	www.global.e-t-a.com/p4499

EPR10 Dimensional drawing

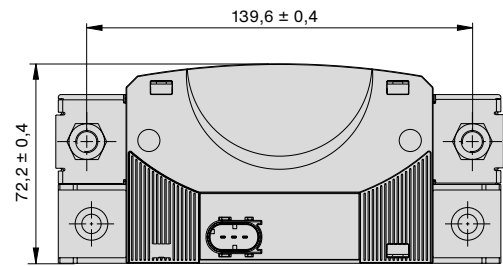



Find more information about high voltage relays here: www.global.e-t-a.com/c17414

HVR10



Description

The HVR10 is based on a hybrid switching concept and combines the benefits of a physical isolation with the performance of semi-conductors.

- Arch-free disconnection
- Physical isolation
- Monitoring of mechanical contact bridges

Typical applications:

- Buses, trucks, construction machinery and specialty vehicles with electrical power train
- Charging stations, energy storage and main relays in the vehicle

HIGH VOLTAGE RELAYS

for the electrified power train.

The HVR10 is a powerful, high-voltage hybrid relay in a compact design. It combines physical isolation of high voltages via an electro-mechanical contact and state-of-the-art semi-conductor technology. The hybrid, arch-free switching system ensures multiple and reliable disconnection of up to 2 Megawatt - 2,000 A/1,000 V even in the event of an overload.

The device can handle higher short circuit currents up to 5,000 A until the fast high-voltage fuse trips. The fist-sized unit can switch and permanently process 300 A up to 100,000 times, arc-free and wear-free. The innovative self-monitoring function immediately signals critical operating conditions to the control unit.

Standards

Meets the requirements according to:

- ISO 16750
- ATF 16949
- ECE R10
- ASIL upon request

Your benefits

- Reliable disconnection even in critical situations up to 2,000 A at 1,000 V
- High protection of the on-board electrical system through integral error detection and indication
- Long typical life through arc-free switching

Technical data

Rated voltage	900 V
Max. voltage	1000 V
Continuous current	300 A
Ambient temperature	-40 ... +85 °C
For more information please visit	www.global.e-t-a.com/p6590

HVR10 Dimensional drawing

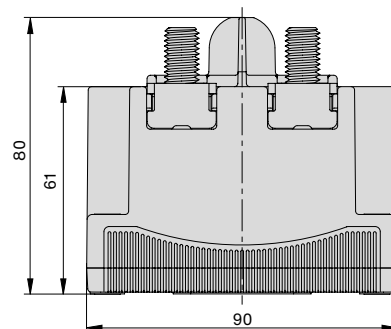



Find more information about electronic solid state relays here: www.global.e-t-a.com/c16571

E-1048-S6



Description

The E-T-A E-1048-S6xx solid state remote power controller is an opto-decoupled transistorised switching device providing both protection and signalling. It is used wherever safe switching and protection of resistive, inductive or illumination loads in DC voltage systems is required.

Typical applications:

- Machine building industry
- Plant engineering

E-1048-S7



Description

The E-T-A solid state remote power controller for PLC outputs E-1084-S7... is a transistor switch with integral protection and signalling functions. It is used in applications where the existing PLC output power is not sufficient. In addition, the device provides protection against short circuit and overload as well as a monitoring function with regard to wire break. The E-1048-S7 solid state remote power controller reduces the number of components such as fuses and relays and avoids the use of expensive powerful output boards.

Typical applications:

- Machine building industry
- Plant engineering

SOLID STATE REMOTE POWER CONTROLLERS

Relay, overcurrent protection and diagnostic functions in a single device

The single pole or double pole electronic solid state remote power controllers combine a relay function with overcurrent protection and diagnostic functions, i.e. three functions in only one module. The devices were designed for the connection to PLC outputs customary in the industry. They protect connected loads against the consequences of short circuit and overload. Besides the switching function typical of a relay, the SSRPCs are also suitable as coupling relays for monitoring the circuit with regard to wire break. They feature a compact design and allow control, protection and load circuit diagnosis without time-consuming wiring efforts. This helps save time and money.

Typical features

Electronic solid state remote power controllers combine three functions in a single module. They offer the best possible load protection and tolerate ambient temperatures up to +60 °C. They can be remotely controlled and are suitable for plug-in and rail mounting.

Your benefits

- Increased machine uptimes through error detection and diagnosis
- Reduced number of components through 3 functions combined in a single unit
- Space-savings through a compact design
- Reduced costs through reduced number of single components
- Time-savings through facilitated wiring

Technical data

Rated voltage	DC 24 V
Rated current	0.5 A, 1 A, 2 A, 4 A
Current limitation	25 A (0.5 A/1 A type) 75 A (2 A/4 A type)
Ambient temperature	0 ... +60 °C
For more information please visit	www.global.e-t-a.com/p133

E-1048-S6 Dimensional drawing

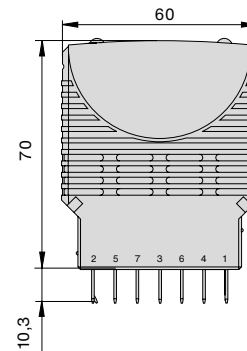

Technical data

Rated voltage	DC 24 V
Rated current	0.5 A, 1 A, 2 A, 4 A, 5 A
Current limitation	25 A (0.5 A/1 A type) 75 A (2 A/4 A/5 A type)
Ambient temperature	0 °C ... +60 °C
For more information please visit	www.global.e-t-a.com/p134/

E-1048-S7 Dimensional drawing

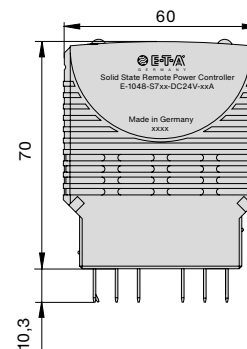

E-1072-128



Description

The E-1072-128 solid state relay with CE marking fully complies with the requirements of EN 60204 part 1 EC Machinery Directive for ungrounded DC 24 V supply systems (>>IT systems<<). It is a double pole electronic solid state remote power controller for magnetic valves (hydraulics, pneumatics), magnetic brakes and clutches with a rated voltage of DC 24 V and a max. rated current of 3 A.

Typical applications:

- Plant engineering (steel industry)
- Power engineering (power plants)

E-1048-8I



Description

The Smart Power Relay E-1048-8I is a remotely controllable electronic relay and holds three functions in a single device:

- Solid state relay
- Electronic overcurrent protection
- Status indication and diagnostic functions

The 7-pole INLINE version e.g. fits into E-T-A's 17-P10-Si terminal block. The rated current of the devices can be adjusted between 1 A to 20 A.

Typical applications:

- Construction machinery
- Agricultural machinery
- Specialty vehicles

E-1072-100



Description

The E-1072-100 solid state relay from E-T-A is a two-pole electronic switching amplifier for resistive, inductive and capacitive loads at DC 24 V and up to 3 A rated current. The switching output prevents the unintentional start-up or dangerous movement of a machine, for example in the event of a ground fault in systems with an ungrounded power supply network (see 89/392/EEC, 93/44/EEC or EN 60204-1 Machinery Directive, section 9.4.3.1).

Typical applications:

- Plant engineering (steel industry)
- Power engineering (power plants)



Technical data

Rated voltage	DC 24 V
Rated current	max. 3 A
Current limitation	typically $2 \times I_N$
Ambient temperature	0 °C ... +50 °C
For more information please visit	www.global.e-t-a.com/p3671

E-1072-128 Dimensional drawing

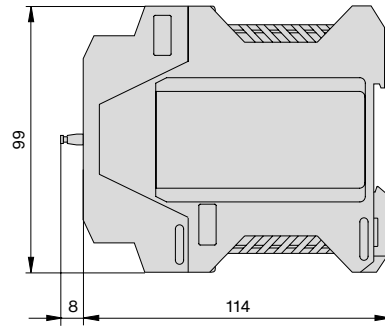

Technical data

Rated voltage	DC 12/DC 24 V
Rated current	Version 1: 1 A, 2 A, 3 A, 5 A, 7.5 A, 10 A Version 2: 15 A/20 A
Current limitation	typically 75 A (version 1) typically 350 A (version 2)
Ambient temperature	-40 °C ... +85 °C
For more information please visit	www.global.e-t-a.com/p136

E-1048-8I Dimensional drawing

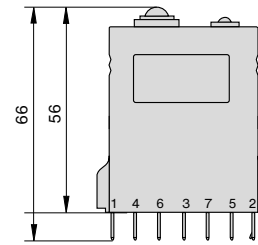

Technical data

Rated voltage	DC 24 V
Rated current	50 mA ... 3.0 A
Current limitation	approx. 12 A
Ambient temperature	0 °C ... +50 °C
For more information please visit	www.global.e-t-a.com/p143

E-1072-100 Dimensional drawing

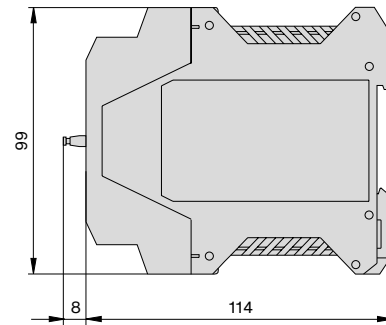

CONVENTIONAL POWER DISTRIBUTION SYSTEMS

Standardised series products
and special solutions



Power distribution modules and power distribution systems for DIN rail mounting

Power distribution systems and modules for overcurrent protection are ideally suitable for compact power supply units. They are typically installed in control cabinets or decentralised power distribution units where the overcurrent protection is connected to a joint supply unit. The individually usable overcurrent protection will protect individual loads and their supply cables against the consequential damages of overcurrent and short circuit.

The 17plus and 18plus power distribution systems can be mounted side by side in a modular design and require very little space. These solutions are suitable for direct rail mounting and offer a complete mounting and power distribution system. They are freely configurable on site

and are perfectly suited for wiring and protecting all loads and their supply lines.

The flexible SVS power distribution systems can be individually adjusted to the respective application. The complete unit is suitable for direct DIN rail mounting. Power distribution, e.g. from a DC 24 V switch mode power supply to several slots can be realised using printed circuit board technology. The required plug-in type circuit breakers are available in many different versions. They ensure the best possible protection of the connected load and its supply line.

Power distribution systems for 19" and control cabinet systems

We offer customised solutions for power distribution and protection, tailor-made to the customer's requirements. For this, we efficiently combine all required elements for power distribution and protection in a single unit.

Tailor-made to the corresponding application, we offer standardised series products as well as individual solutions for complex tasks. Our solutions convince through their integral protection, facilitated installation, minimum space requirements and cost-effectiveness.

Our well-proven modular system allows accommodation of maximum performance in minimum space.

Applications

- Vehicles (AC 230 V, AC 400 V, DC 12 V, DC 24 V, DC 48 V, DC 400 V)
- Automation (AC 230 V, AC 400 V, DC 24 V, DC 48 V, DC 400 V)
- Telecommunications (AC 230 V, AC 400 V, Minus DC 48 V, Minus DC 65 V, Minus DC 400 V)

Solutions

- **Power-D-Box**[®]-systems
- Power-Distribution-Modules
- Power-Board-Modules



Find more information about power distribution modules and systems here: www.global.e-t-a.com/c10853

**Power distribution system
18plus “compact” system**

optionally fitted with

- ESS30-S electronic circuit breakers
- ESX10 electronic circuit protectors
- 2210-S thermal-magnetic circuit breakers

Line terminals PLUS screw terminals PLUS signalling terminals PLUS integral wiring harness PLUS flexible circuit breaker population. More than 18 positive features complement each other in their effect!



**Power distribution system
optionally fitted with**

- ESS30-S electronic circuit breakers
- ESX10 electronic circuit protectors
- 2210-S thermal-magnetic circuit breakers

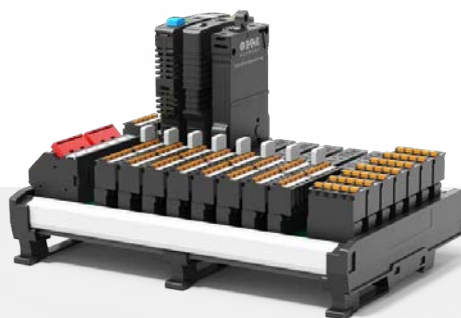

POWER DISTRIBUTION MODULES AND SYSTEMS

Compact, flexible and cost-effective

17plus and 18plus power distribution modules

The 17plus and 18plus power distribution modules combine selective overcurrent protection with a flexible, modular power distribution in load circuits. These solutions are flexible, can be easily adjusted individually and are therefore extremely cost-effective.

Your benefits:

17plus and 18plus modules

- Flexibility through a modular design
- Reduced costs through individual adjustment options to the application
- Reduced wiring time through quick and centralised wiring
- Space-saving thanks to the slim module design

SVS power distribution systems

The SVS power distribution systems combine selective overcurrent protection with the power distribution in load circuits and provide a compact solution within a single system. This is what makes SVS solutions so efficient and cost-effective.

Your benefits:

SVS power distribution systems

- Cost-saving – through reduced wiring efforts and reduced number of components
- Space-saving – through a compact and centralised distribution in a single component
- Time-saving – through unified planning concept and clear power distribution arrangement

Supply module
18plus-EM



Connection module
18plus-AM



Signalling module
18plus-SM

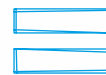

Power distribution system
18plus module



Printed circuit
board



Connector



Power distribution
system



17plus module



Description

The 17plus module is a mounting and power distribution system. It consists of individual components accommodating two single pole circuit breakers or overcurrent protection devices with a width of 12.5 mm. They are plugged into the 17plus module and snapped onto a DIN rail.

Can be combined with:

- 2210-S, 3600, 3900 circuit breakers
- ESS30 electronic circuit breakers and ESX10 electronic circuit protectors
- E-1048-S7... solid state remote power controller

18plus module



Description

The 18plus power distribution module is a compact wiring solution for all load and signal lines of the DC 24 V control voltage whether it is a decentralised power distribution or a centralised system concept. The system can be equipped with different E-T-A circuit breakers and protectors and includes a complete mounting and power distribution system with state-of-the-art push-in-technology for DIN rail mounting.

Can be combined with:

- 2210-S
- ESS30, ESX10

SVS04



Description

The SVS04 power distribution module for DIN rail mounting distributes the current of a switch mode power supply to four or eight slots and selectively protects the connected loads via integrated circuit breakers. With up to 8 A load current per channel and 40 A total current, it simplifies routing and sub-routing in short circuit current-limited DC 24 V applications. Five protected »L+« outputs per slot and 15 or 300 minus terminals significantly help reduce the usual wiring time.

Can be combined with:

- 2210-S, ESS30, ESX10

SVS25



Description

The SVS25 power distribution system meets all requirements of the automation technology with regard to reliable overcurrent protection and optimised current distribution. It distributes the voltage potential supplied by a DC 24 V switch mode power supply to eight slots for DIN rail mounting. It also selectively protects the connected loads via REF16-S101-DC24V circuit protectors. Ten protected plus outputs and ten minus terminals per slot significantly reduce the wiring effort.

Can be combined with:

- REF16



Technical data

Rated voltage	AC 250 V; 3 AC 433 V; DC 65 V (without circuit breaker)
Rated current	max. 50 A total current
Signalling	Group signalling max. 10 A max. 1 A per channel
For more information please visit	www.global.e-t-a.com/p109

17plus module Dimensional drawing

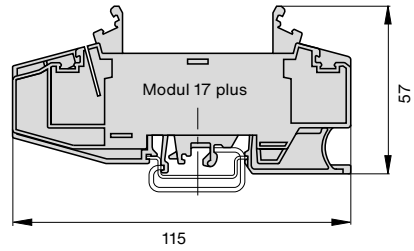

Technical data

Rated voltage	DC 24 V
Rated current	max. 80 A total current
Signalling	make contacts connected in series
For more information please visit	www.global.e-t-a.com/p4472

18plus module Dimensional drawing

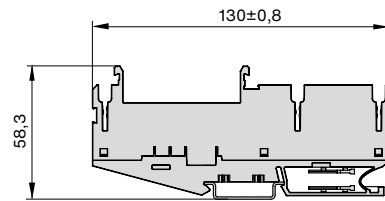

Technical data

Rated voltage	DC 24 V
Rated current	max. 40 A total current
Signalling	Group signalling DC 30 V/0.5 max. signal outputs pre-wired on PCB
For more information please visit	www.global.e-t-a.com/p1050

SVS04 Dimensional drawing

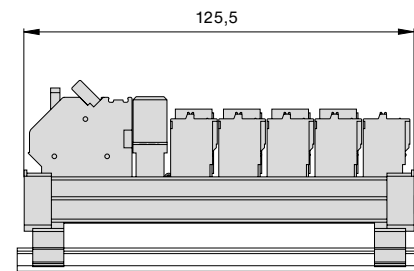

Technical data

Rated voltage	DC 24 V (18 ... 30 V)
Rated current	max. 40 A total current
Breaking capacity I_{on}	Group signalling DC 24 V/max. 0.5 A
For more information please visit	www.global.e-t-a.com/p4413

SVS25 Dimensional drawing

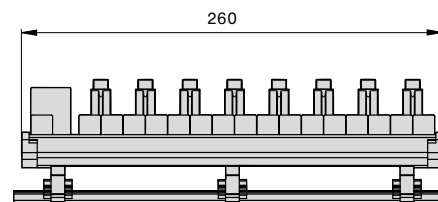



© m.mphoto - stock.adobe.com



Find more information about power distribution modules and systems here: www.global.e-t-a.com/c10854

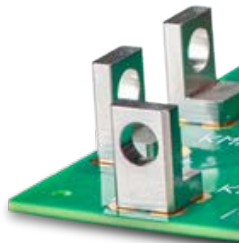
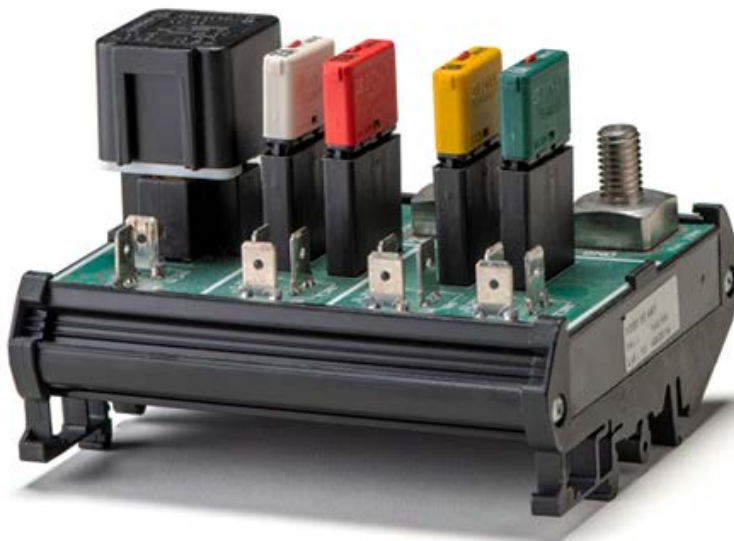

CUSTOMER-SPECIFIC SYSTEM SOLUTIONS

Electrical system and CAN solutions for mobile machines

E-T-A system solutions is a team of experts, developing electrical system and CAN solutions for different vehicles according to your requirements, ideas and technical specifications. Our motivation for each project we realise is finding reliable solutions which are easy to install and maintain in cooperation with our customers.

Our solutions for you:

- Innovative E-T-A components combined in coordinated solutions
- Individual printed circuit board solutions, from the plain power distribution module to the energy and data distribution module
- Facilitated integration and compact housing solutions up to IP6K9K
- High-voltage solutions
- Integration of complete CAN systems, from the power distribution module to the HMI
- Economic solutions at small quantities

Your benefits:

- System optimisation adjusted to your application: We develop solutions perfectly adjusted to the application together with our customers
- Plug-and-Play: Simplified vehicle integration through many plug-in connector options
- Facilitated maintenance and aftersales: Flexible replacement through plug-in type components
- Cost-savings and risk minimisation: Extremely short mounting times and risk minimisation through pre-wired plug-in connectors

Typical applications:

- Trucks
- Buses
- Agricultural vehicles and forestry equipment
- Construction machinery
- Specialty vehicles

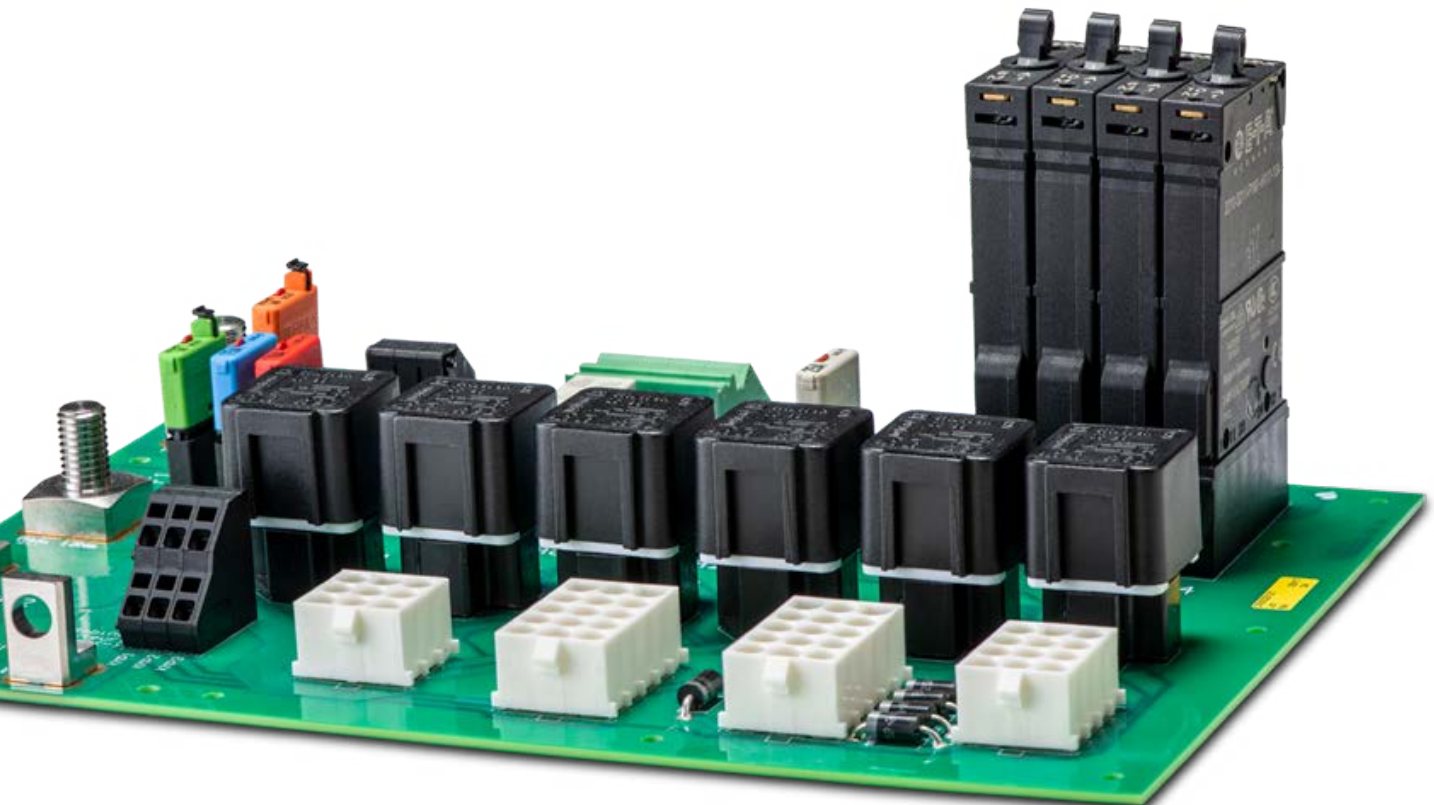



Find more information about Power-D-Box® here: www.global.e-t-a.com/c10633



Different plug-in type fuse elements
ESS30, ESX10-S, 8345, 2210-S, 8340, 3600

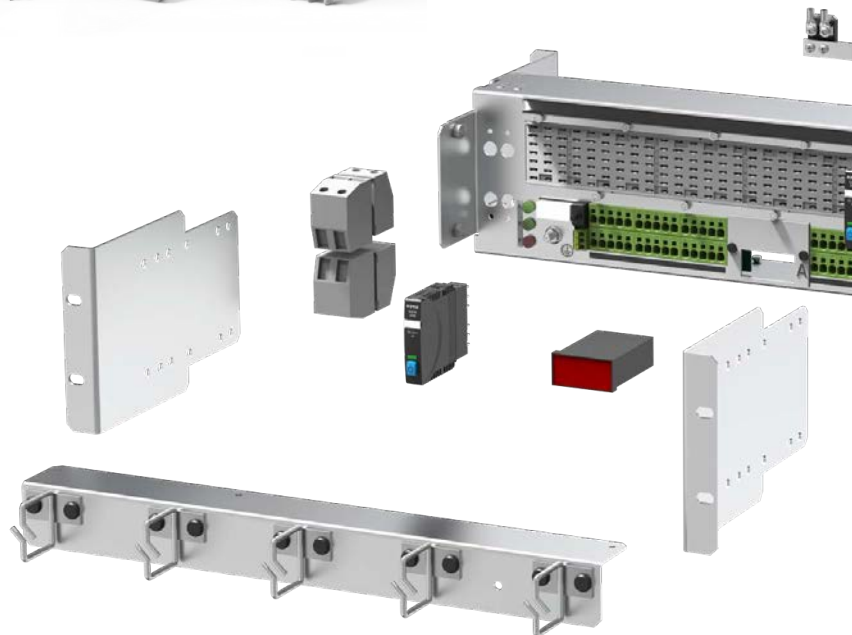

Power-D-Box® SYSTEMS

From a single component to sub-distribution to the entire control cabinet

A wide range of options

- The **Power-D-Box®** and Power Distribution modules ensure optimised power distribution, selective overcurrent protection and intelligent signalling based on PCB technology.
- **The Power-D-Box®** and Power Distribution modules in a 19" design can be fully adapted to the customers' needs. According to the »plug and play« principle, they only have to be connected.
- We also offer complete control cabinet solutions, which provide even more compact accommodation of your power distribution systems, e.g. as so-called **BonsaiCabinet®**.

Successful in many markets

Chemical industry, foodstuffs and pharmaceutical industry, power engineering and power plants (signalling and transmission technology), oil and gas, car production, data centres and telecommunications: These are the key industries for our products and applications.



Technology

Our system solutions are suitable for the voltage levels AC 230 V, AC 400 V, DC 24 V, DC 48 V, DC 400 V, minus DC 48 V, minus DC 65 V, minus DC 400 V at various current ratings. The system solutions of our **Power-D-Box®** and Power Distribution module series enable compact power distribution featuring the key requirements of safety, transparency and a space-saving design, as well as redundancy and selectivity.

The modular design allows flexible, reliable and easy extension of our power distribution systems.

Other parts of our power distribution systems are back-up fuses which are integrated in the supply modules. In addition, they feature a reliable, selective DC 24 V protection with electronic circuit protectors, a modular design to increase the number of channels and a clear cable management.

Your benefits

- Significantly shorter lead times for your product
- No time-consuming tests required, all components are optimally coordinated
- No preparation works necessary, as E-T-A offers complete solutions

Modular power distribution systems can be exactly adapted to the application.

They include:

- Practical cable management
- Optional total current display
- Load terminals with push-in technology
- Compact wiring by means of PCB
- Decoupling diodes with integral heat sink
- Reversible flanges (for 19" rack mounting or backplane mounting)

The modular system helps reduce the project run time.

PDB – Printed circuit board



Description

The **Power-D-Box®** with 2HU PCB can be fitted with 3600, 3900, 2210 plug-in thermal-magnetic circuit breakers, ESX10 electronic circuit protectors or ESS30 circuit breakers. Group signalisation and current routing are compactly integrated on the printed circuit board. The connection is made via terminals directly on the circuit board or via additional terminals. A voltage display and decoupling of redundant feeds via decoupling diodes are optionally available.

Typical applications:

- Process control

PDB – Economy



Description

The Economy **Power-D-Box®** is a compact power distribution system. The redundantly designed system can be equipped with 8340-F or 8335 circuit breakers. The busbars, as well as the group signalisation are finger-safe insulated in a plastic housing, which prevents contact with live components. Connection of loads is from the front via blade terminals which are protected against reverse polarity. Besides various preferred types, we can offer individual solutions, perfectly tailored to your application.

Typical applications:

- Telecommunications

PDB – High Power



Description

The High **Power-D-Box®** is a compact power distribution system. The system can be equipped with 8345 circuit breakers. The entire current routing and group signalisation are finger-safe installed in a metal housing, which prevents contact with live components. Depending on the application, the loads can be connected on the rear or on the front by means of screw terminals. Besides various preferred types, we can offer individual solutions, perfectly tailored to your application.

Typical applications:

- Process control • Telecommunications

PDM

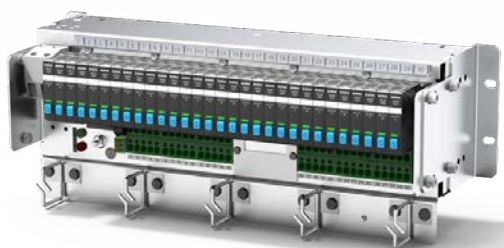

Description

The power distribution module can be equipped with pluggable 3600, 3900, 2210 thermal-magnetic circuit breakers, the ESX10 electronic circuit protectors or with ESS30 electronic circuit breakers. The group signalisation and the entire conduits feature a compact PCB design. Connection is done via spring-loaded terminals, the supply feed is connected via screw terminals. Cable organizers, current display or junction of two redundant supply lines via de-coupling diodes are optionally available.

Typical applications:

- Process control



Technical data

Rated voltage	Max. AC 50 V/230 V Max. DC 65 V
Rated current	Total current max. 100 A/ 80 A Individual load max. 16 A
Number of channels	Max. 1 x 30 Max. 2 x 15 redundant
Cable cross sections	Supply max. 35 mm ² Load max. 2.5 mm ²
For more information please visit	www.global.e-t-a.com/p6735

PDB – Printed circuit board Dimensional drawing

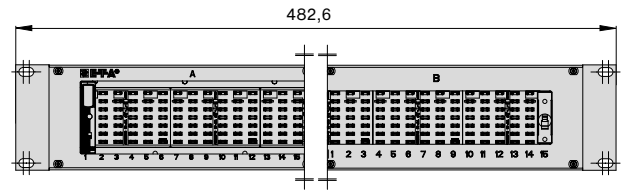

Technical data

Rated voltage	Max. DC 80 V
Rated current	Total current max. 132 A Individual load max. 25 A (30 A upon request)
Number of channels	2 x 8
Cable cross sections	Supply max. 50 mm ² Load max. 6 mm ²
For more information please visit	www.global.e-t-a.com/p1496

PDB – Economy Dimensional drawing

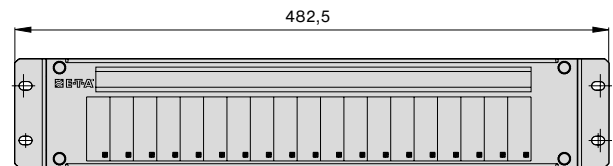

Technical data

Rated voltage	Max. DC 80 V
Rated current	Total current max. 232 A Individual load max. 125 A
Number of channels	2 x 8
Cable cross sections	Supply max. 95 mm ² Load max. 35 mm ²
For more information please visit	www.global.e-t-a.com/p1038

PDB – High Power Dimensional drawing

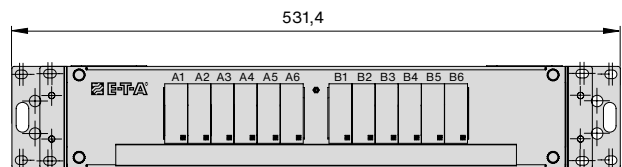

Technical data

Rated voltage	Max. AC 50 V Max. DC 50 V
Rated current	Total current max. 100 A Individual load max. 16 A
Number of channels	1 x 30 2 x 2 redundant
Cable cross sections	Supply max. 35 mm ² Load max. 2.5 mm ²
For more information please visit	www.global.e-t-a.com/c19840

PDM Dimensional drawing

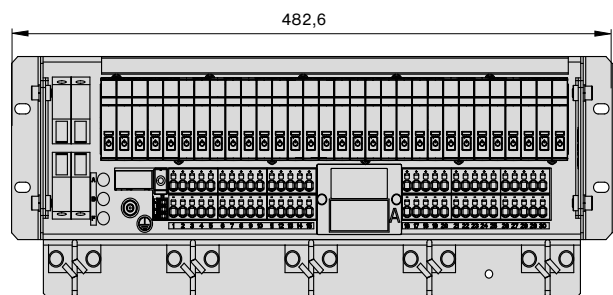

INTELLIGENT POWER DISTRIBUTION SYSTEMS

Intelligent complete systems for power distribution and overcurrent protection



SCS® Smart Control Systems for utility vehicles

The **SCSSmart Control Systems®** is an intelligent power distribution solution in vehicles with CAN communication. Comprehensive diagnostic functions allow early error detection and reduce or prevent consequential damage, vehicle breakdowns and downtimes. Existing CAN networks can be extended easily and quickly through the flexible and compact CAN controllers.

Applications:

- Agricultural vehicles and forestry equipment
- Construction machinery
- Specialty vehicles
- Trucks
- Buses

ControlPlex® Rack for Datacentres and Telecommunications

ControlPlex® Rack is the intelligent complete solution for power distribution and overcurrent protection in the telecommunications sector, combined with smart control and monitoring technology. Thanks to selective protection, the modular system ensures unrivalled equipment uptime and provides the user a convenient remote management in addition to performance data recordings.

With the **ControlPlex® Rack E-T-A** provides tailor-made complete solutions for power distribution and protection, according to the customer's specification.

Applications:

- Telecommunications (Minus DC 48 V, Minus DC 65 V)

Solutions:

- **ControlPlex®** Rack systems

ControlPlex® DINrail for plant engineering and process automation

The flexible **ControlPlex® DINrails** are intelligent power distribution and protection solutions for direct DIN rail mounting. They can be adapted and extended without any problem thanks to their modular design. The connection to the superordinate control system via PROFINET, EtherCAT, EtherNet IP, Modbus TCP, IO link and Modbus RTU ensures transparency of your DC 24 V supply. Unintended process downtimes are prevented and

machine and system availability are increased through continuous measuring data recording.

Applications:

- Machine construction and process control
- Process automation
- Building automation

PowerPlex® for boats and mobile homes

PowerPlex® is a modular, CAN bus-based control system, which helps realise intelligent on-board electrical systems in boats and mobile homes. Increasing digitisation makes smart on-board electrical systems in this sector a major subject in global competition. E-T-A's **PowerPlex®** system provides an overall concept for networking and controlling the on-board electronics, significantly increasing comfort and safety. Whether intelligent control units with

touchscreen, automatic sensors and manual pushbuttons or smartphone and tablet applications – with **PowerPlex®** you keep control of the entire on-board electrical system.

Applications:

- Boats, Yachts
- Caravans, mobile homes

E-BOX for mobile homes

Thanks to the all-in-one concept, the most important components are compactly accommodated in a single enclosure – eliminating the need for complex sub-wiring. This saves time, reduces errors and is a real game changer in the industry. The touch panel allows you to see

the tank levels and battery charge at a glance. Acoustic warnings ensure safe filling and safe departure.

Applications:

- Camper vans, urban camper vans, panel vans



You can find more information about SCS® Smart Control Systems here: www.global.e-t-a.com/c18375

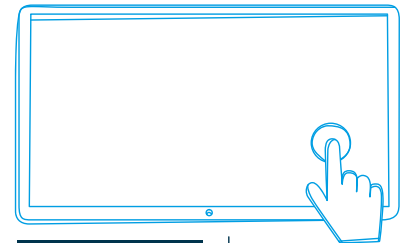
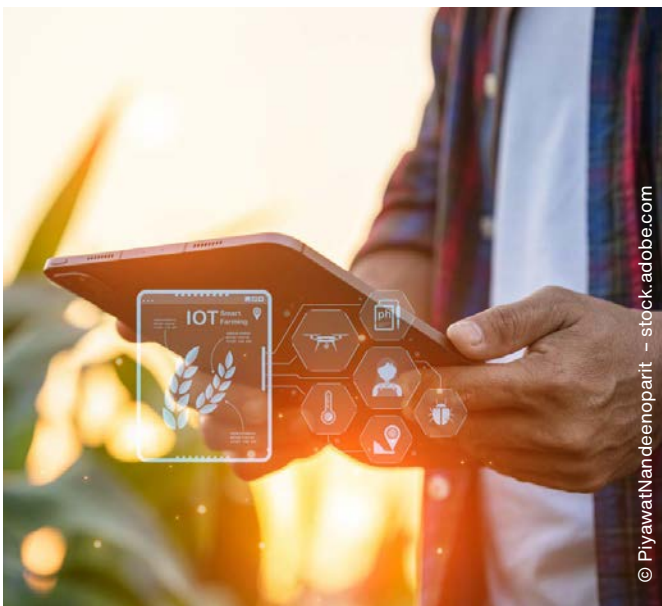

Touchscreen

ECU

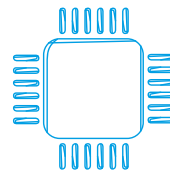

Keypad

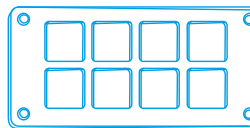

SCS® SMART CONTROL SYSTEMS

Intelligent power distribution in utility vehicles with CAN communication

The CAN bus technology and the SAE J1939 network protocol based on the CAN 2.0B specification are the standard for the networking of components in utility vehicles of all kinds. The Smart Control Systems product group developed by E-T-A complies with this standard and, with the SCS200, also supports the CANopen standard. A major benefit of this technology is the decreased number of cables saving material and production costs, as switching elements can be directly switched ON or OFF and diagnosis information can also be sent via the CAN bus.

The SCS1000 and SCS3000 high-performance power distribution modules combine power distribution of high currents and handling of complex loads with integral logics, control functions and CAN connection in an extremely compact design. Even without an external ECU, logic links and calculations can be implemented in the device itself. The PDUsetup graphical programming environment allows flexible configuration of the SCS1000 and SCS3000 adapted to the application.

The intelligent SCS200 power distribution module provides comprehensive diagnoses information, such as load current per channel, total current, voltage and output status, as well as overload alarm. The diagnostic functions allow early error detection and reduce or prevent consequential damage, vehicle breakdowns and downtimes.

E-T-A's SCS products help digitise the on-board electrical network and reduce complexity at the same time. We will be happy to support you in your first steps into the CAN world, which can be easily realised with our SCS product group.

Typical applications:

- Construction machinery
- Forestry equipment and agricultural vehicles
- Specialty vehicles
- Trucks
- Buses

Your benefits:

- Versatile use through easy integration into existing CAN networks
- Digitisation of the on-board electrical systems through CAN interfaces
- Increased safety and load management through diagnostic functions

SCS® Smart Control Systems

uses CAN bus technology and the SAE J1939 network protocol for networking components in commercial vehicles.

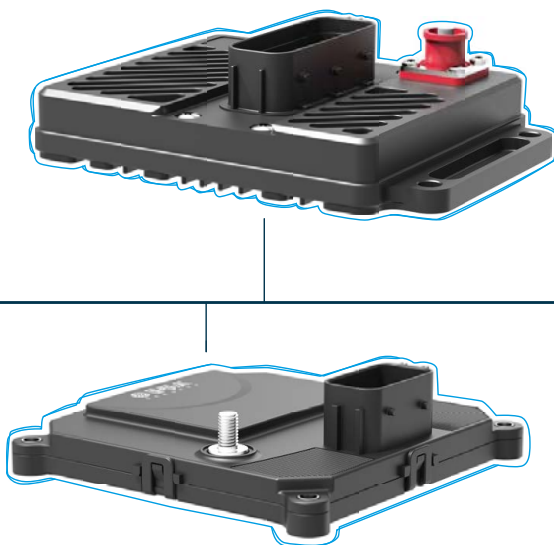

CAN Bus

SCS200



Description

It is an intelligent power distribution system allowing decentralised control and monitoring of loads via CAN bus. The design features a PCB-based power distribution in a compact IP67 enclosure. This Plug & Play solution helps you reduce wiring efforts and save space. The diagnostic functions and integral CAN connection ensure both safety and connectivity.

Diagnostic functions:

- Load current
- Voltage
- Overload message
- Total current
- Output status

SCS1000



Description

The SCS1000-16 combines performance and logic in one module and is the perfect solution for smaller system architectures. The intelligent power distribution system with 16 outputs is available in a high-side switching version.

The SCS1000 modules can be flexibly configured via a graphic programming environment.

Typical applications

- Specialty vehicles
- Off-Highway vehicles
- Construction machinery and agricultural vehicles
- Utility vehicles

SCS3000



Description

The SCS3000 modules combine performance and logic in one device. With 34, 48 or 64 outputs and many interfaces, these intelligent high-performance power distribution modules are highly suitable for large system architectures. The 16 outputs version is suitable for smaller, decentralised system architectures. The SCS3000 modules can be flexibly configured via a graphic programming environment.

Typical applications

- Specialty vehicles
- Off-Highway vehicles
- Construction machinery and agricultural vehicles
- Utility vehicles



Technical data

Rated voltage	DC 12 V, DC 24 V, DC 48 V
Max. load current per load channel	4 x 30 A (12 V), 2 x 25 A (24 V), 3 x 15 A (48 V), all other channels 10 A
Analogue inputs	6
Communication	SAE J1939, CANopen, CAN 2.0B
IP code	IP66 / IP67
Ambient temperature	-40 ... +85 °C
For more information please visit	www.global.e-t-a.com/p6593

SCS200 Dimensional drawing

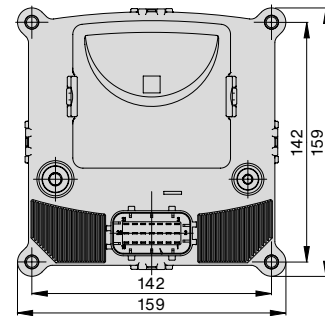

Technical data

Rated voltage	DC 12 V/DC 24 V
Total current	160 A
Outputs	16 (4 x 32.5 A)
Communication	CAN 2.0B, SAE J1939
Ambient temperature	-40 ... +85 °C
For more information please visit	www.global.e-t-a.com/p6635

SCS1000 Dimensional drawing

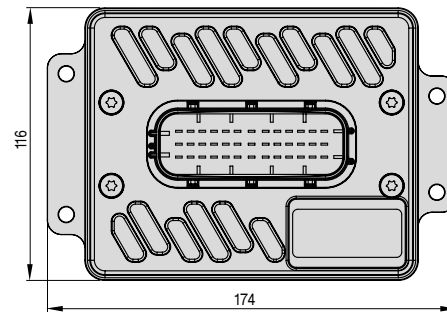

Technical data

Rated voltage	DC 12 V/DC 24 V
Total current	SCS3000-34, 48, 64: 280 A SCS3000-16: 200 A
Outputs	16 (4 x 35 A & H-bridges) 34/ 48/ 64 (10 x 35 A & H-bridges)
Communication	CAN 2.0B, Ethernet, RS232
Ambient temperature	-40 ... +85 °C
For more information please visit	www.global.e-t-a.com/p6636

SCS3000 Dimensional drawing

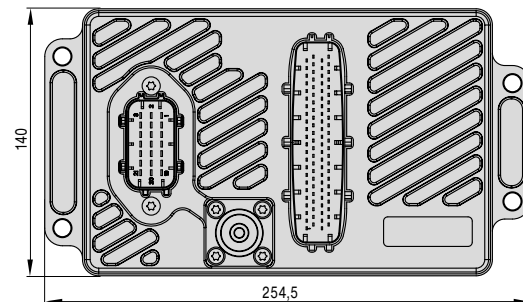



© Blue Planet Studio - stock.adobe.com



Find more information about the EM12D ControlPlex® system here:
www.global.e-t-a.com/c17671

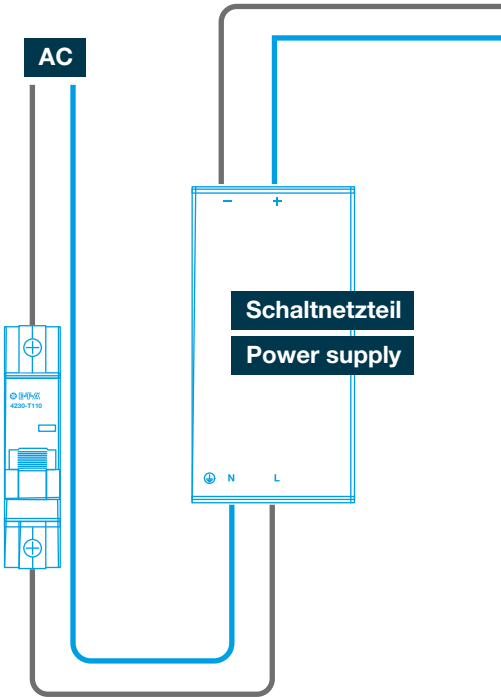

© ipobpa - stock.adobe.com

ControlPlex® - EM12D SYSTEM

System transparency and remote access for machine construction and process control

The requirements for modern machinery and equipment are constantly growing. Therefore, system transparency, remote maintenance and remote access have become competitive edges.

The intelligent REX system is the perfect solution for the machine building industry. It combines the proven quality of DC 24 V overcurrent protection with the communication capability of IO link and Modbus RTU.

This enables comprehensive transparency of the DC 24 V power supply and provides all necessary information for a stable production process in this system area. The new generation of the REX electronic overcurrent protection system combines the intelligent EM12D supply module and the REX12D or REX22D electronic circuit protectors, available as single or double pole versions, in a modular design so that they can be mounted side by side.

Features and Benefits

- Control, diagnosis and monitoring via IO link and Modbus RTU
- Selective load protection by means of electronic trip curve
- No accessories required to connect the components
- Only 6.25 mm per channel (2-channels)
- Fixed or adjustable current ratings up to 20 A.
- Manual ON/OFF/reset momentary switch
- Connection via push-in terminals including terminal actuator

Benefits:

- Increased machine availability through high transparency and remote diagnosis
- Cost-saving as no further accessories are required
- Space-saving with a width of only 6.25 mm per channel
- Highly flexible current ratings from 1 A to 20 A

Your smart DC 24 V protection with  IO-Link and  Modbus RTU

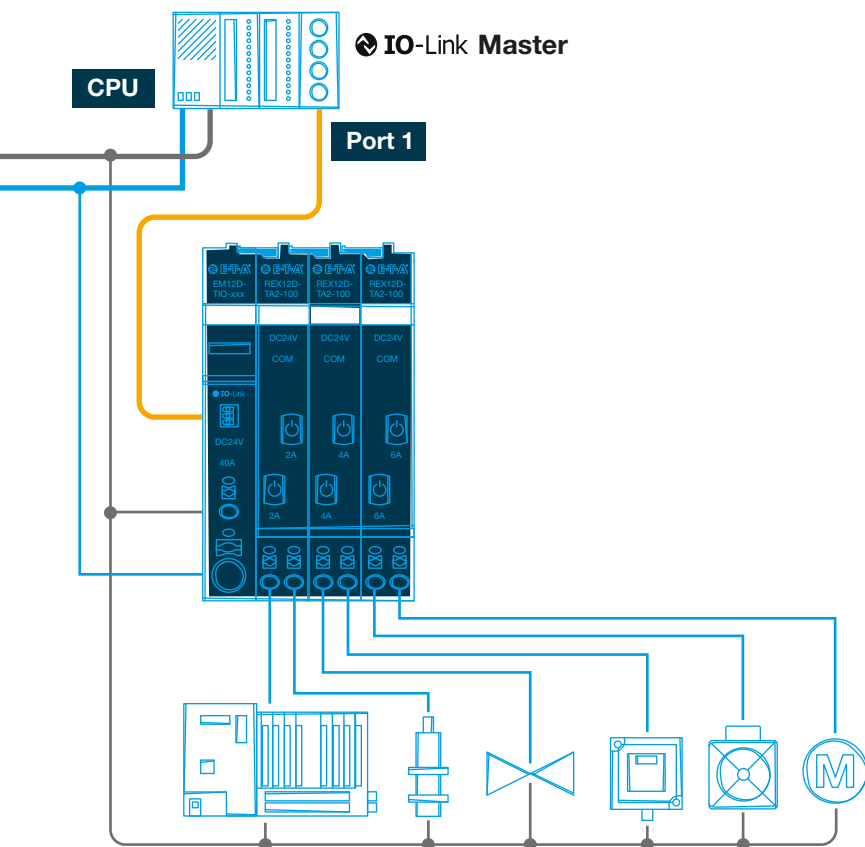

The system offers a quick and comprehensive diagnosis of your DC 24 V power supply. It enhances system transparency and significantly increases machine uptime.



Schematic diagram corresponds to a IO link connection.

EM12D



Description

The intelligent EM12D supply module takes up the DC 24 V supply voltage, and distributes it to the installed circuit protectors via the integral connector arm of the REX12D. The EM12D transmits a high number of measuring values, diagnostic information and control commands to a superordinate IO link master or Modbus master at the control level. They include:

Reading measuring values:

Device status/event, load voltage, load current

Control commands: Switch ON-/OFF load output

Including electronic circuit protectors

REX12D and REX22D

PM12



Description

There are two main groups of the PM12D power distribution concept of the REX system. In the same system, the user can easily realise not only the + DC 24 V distribution, but also the minus - distribution 0 V (GND).

Typical applications:

- Machine building industry

REX12D



Description

The REX12D electronic circuit protector is only 12.5 mm wide and features push-in technology including a push button. It allows time-saving and maintenance-free wiring without any tools. You don't need additional accessories for electrical or mechanical connection of the individual components. This helps save time and money!

Different adjustable current ratings help protect not only powerful loads, but also sensitive loads and smallest cable cross sections. Errors can be clearly detected and remedied in a targeted way.

REX22D



Description

The new REX22D completes the REX system and combines a trip curve with situated, active linear current limitation with the typical slim design. The REX22D provides effective protection for all applications with DC 24 V switch mode power supplies with a small overload capacity and for characteristic curves designed for DC 24 V drive technology.

Typical applications:

- Machine building industry
- Car production
- Automation



Technical data

Operating voltage	DC 24 V (18 ... 30 V)
Rated current	max. 40 A
Quiescent current	typically 20 mA
Ambient temperature	-25 °C ... +60 °C
For more information please visit	www.global.e-t-a.com/c17197

EM12D Dimensional drawing

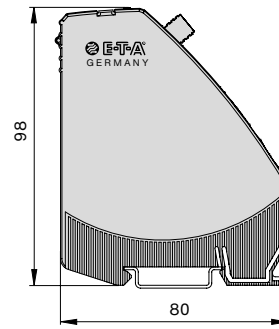

Technical data

Operating voltage	DC 24 V (18 ... 30 V)
Rated current	max. 20 A
Ambient temperature	-30 ... +60 °C
For more information please visit	www.global.e-t-a.com/c17197

PM12 Dimensional drawing

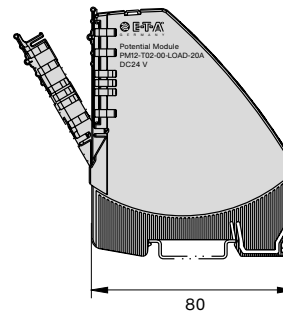

Technical data

Operating voltage	DC 24 V (18 ... 30 V)
Rated current	Single-channel: 8 A, 10 A double channel: 1 A/1 A, 2 A/2 A, 3 A/3 A, 4 A/4 A, 6 A/6 A, 1A-10 A
Quiescent current	in ON condition: max. 10 mA
Ambient temperature	-25 °C ... +60 °C (without condensation, cf. EN 60204-1)
For more information please visit	www.global.e-t-a.com/p4507

REX12D Dimensional drawing

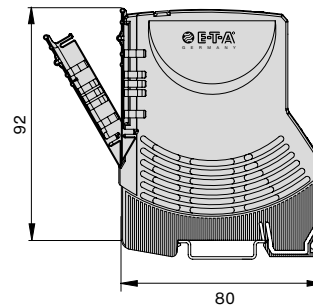

Technical data

Rated voltage	DC 24 V (18 ... 32 V)
Rated current	1 A... 20 A fixed or adjustable
Load circuit disconnection	Overload disconnection (I_{UL}) typ. 3s short circuit disconnection (I_{KS}) typ. 0.01 to 1 s
Ambient temperature	-30 ... +60 °C
For more information please visit	www.global.e-t-a.com/p6696

REX22D Dimensional drawing

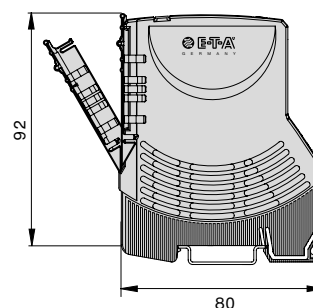



© jason - stock.adobe.com



Find more information about the
CPC12 ControlPlex® system here:
www.global.e-t-a.com/c18179



ControlPlex® CPC12 SYSTEM

Transparency across all levels of the automation pyramid

The CPC12 **Control-Plex**® system has a permanent measuring data acquisition, analysis and processing system. This provides the required transparency to detect changes in the production process at an early stage and initiate corrective actions in time.

The integral web server of the CPC12 bus controller allows direct access to the data of the DC 24 V power distribution. All measuring data and status information can be accessed even without using the field bus interface. This is a special benefit for the maintenance staff, because they can access the required information quickly during the first start-up or in the event of machine breakdowns.

Typical Features

- Integral webserver allows direct access to data
- Measuring values and status information can be

transmitted to the superordinate control systems and all circuit protectors can be accessed remotely via connection to PROFINET, EtherNet/IP, Modbus TCP or EtherCAT.

- No accessories required to connect the components
- Status indication, measuring value logging and analysis, circuit protector remote control, parametrisation, trip counter and root cause analysis

Benefit

- Increased machine and system uptime through clear failure detection, high transparency and remote diagnosis
- Space-saving through the slim design of the circuit protectors and potential modules
- Increased flexibility of machine planning through a wide range of different modules



With the CPC12 bus controller, the REX system creates transparency across all levels of the automation pyramid.

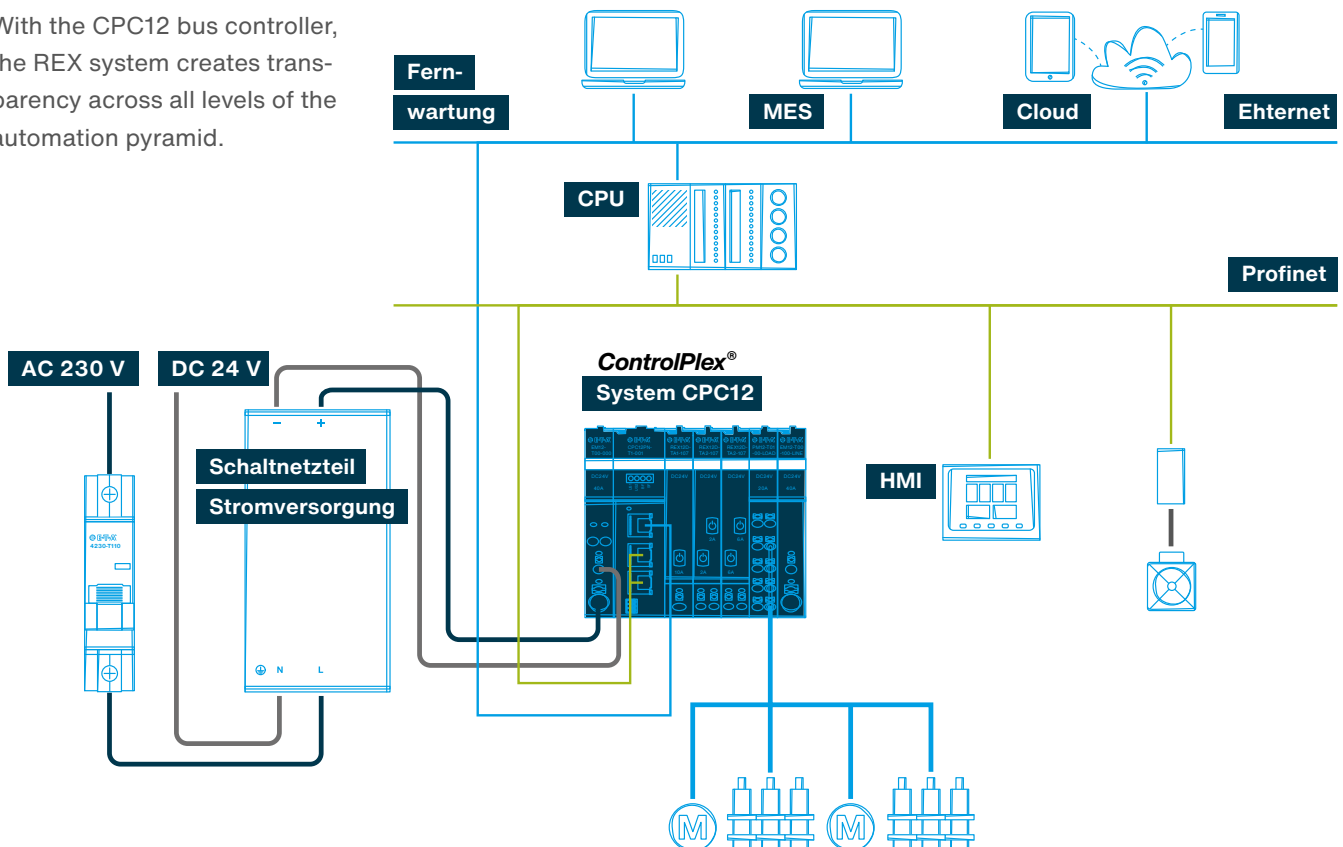

CPC12



Description

The CPC12 bus controller collects the status information and measuring values of the connected circuit protectors. These data are forwarded to the superordinate control systems via the PROFINET, EtherCAT, Modbus TCP and EtherNet/IP field bus interfaces. This creates transparency and allows remote access to all necessary information and functions of the DC 24 V power distribution.

Typical applications

- Machine construction and process control

REX12D



Description

The REX12D electronic circuit protector is only 12.5 mm wide and features push-in technology including a push button. It allows time-saving and maintenance-free wiring without any tools. You don't need additional accessories for electrical or mechanical connection of the individual components. This helps save time and money!

Different adjustable current ratings help protect not only powerful loads, but also sensitive loads and smallest cable cross sections. Errors can be clearly detected and remedied in a targeted way.

REX22D



Description

The new REX22D completes the REX system and combines a trip curve with inclusive, situational, active and linear current limitation with the typical slim design. The REX22D provides effective protection for all applications with DC 24 V switch mode power supplies with a small overload capacity and for characteristic curves designed for DC 24 V drive technology.

Typical applications:

- Machine building industry
- Car production
- Automation



Technical data

Operating voltage	DC 24 V
Rated current	max. 40 A
Ambient temperature	-30 °C ... +60 °C
For more information please visit	www.global.e-t-a.com/c18179

CPC12 Dimensional drawing

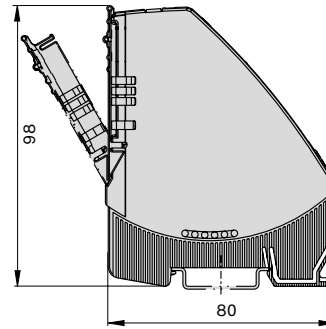

Technical data

Operating voltage	DC 24 V (18 ... 30 V)
Rated current	Single-channel: 8 A, 10 A double channel: 1 A/1 A, 2 A/2 A, 3 A/3 A, 4 A/4 A, 6 A/6 A, 1A-10 A
Quiescent current	in ON condition: max. 10 mA
Ambient temperature	-25 °C ... +60 °C (without condensation, cf. EN 60204-1)
For more information please visit	www.global.e-t-a.com/p4507

REX12D Dimensional drawing

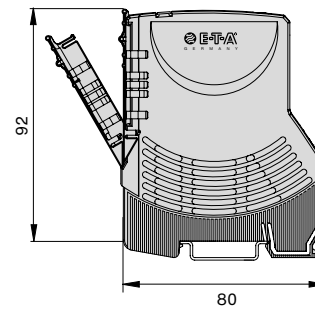

Technical data

Rated voltage	DC 24 V (18 ... 32 V)
Rated current	1 A ... 20 A fixed or adjustable
Load circuit disconnection	Overload disconnection (I_{UL}) typ. 3 s short circuit disconnection (I_{KS}) typ. 0.01 to 1 s
Ambient temperature	-30 ... +60 °C
For more information please visit	www.global.e-t-a.com/p6696

REX22D Dimensional drawing

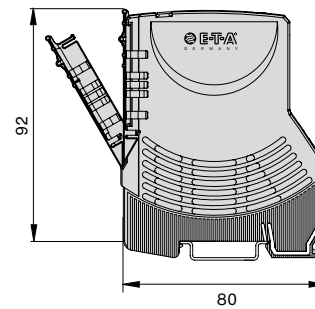



Find more information about the CPC20 *ControlPlex*® system here: www.global.e-t-a.com/c17673



The CPC20 power distribution system enables intelligent and transparent protection of the DC 24 V power distribution. Status information and measuring values of the circuit protectors can be accessed at all levels of the control pyramid via the PROFINET, Ethernet/IP and JSON interfaces.

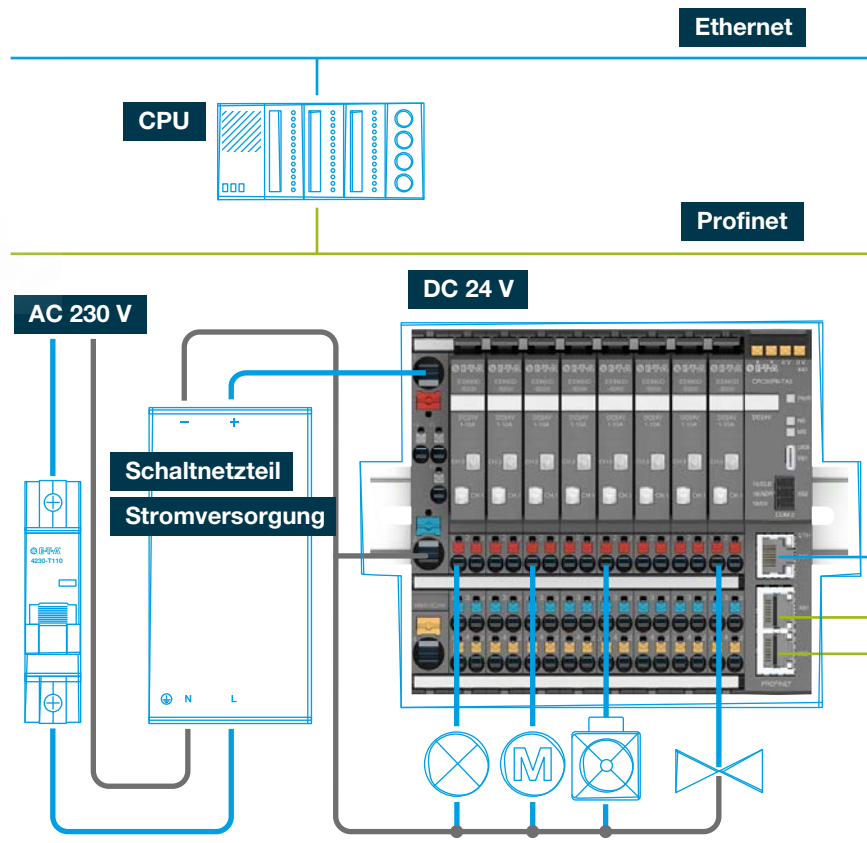

ControlPlex® -CPC20 SYSTEM

Intelligent DC 24 V power supply – protection included

Intelligent power distribution systems increasingly find their way into industrial production plants. In terms of predictive maintenance, their main purpose is to increase system availability, to ensure stable production processes, to avoid undesired downtimes and to provide system flexibility.

This purpose is best served by the system's consistency from the field level to the cloud. System data are available everywhere and provide the required transparency. Undesirable developments can quickly be identified and remedied. This ensures stable production processes and a constantly high quality.

Besides the PROFINET and EtherNet/IP interfaces, the system has an additional Ethernet interface, which allows data transmission via JSON (in preparation). The operator can also connect to the integral web server and request and analyse all key data of the DC 24 V power distribution.

Features and Benefits

- Permanent data logging and status monitoring
- Visualisation of measured data
- Profinet and EtherNet Ethernet/IP
- JSON
- Integral webserver
- Separate power supply

Typical applications:

- Plant engineering
- Car production
- Chemicals and steel industry
- Pharmaceuticals and foodstuffs

Benefits:

- Increased system availability through comprehensive diagnostic functions
- Improved protection against voltage dips through selective load protection
- Increased flexibility of system planning through a modular terminal block system

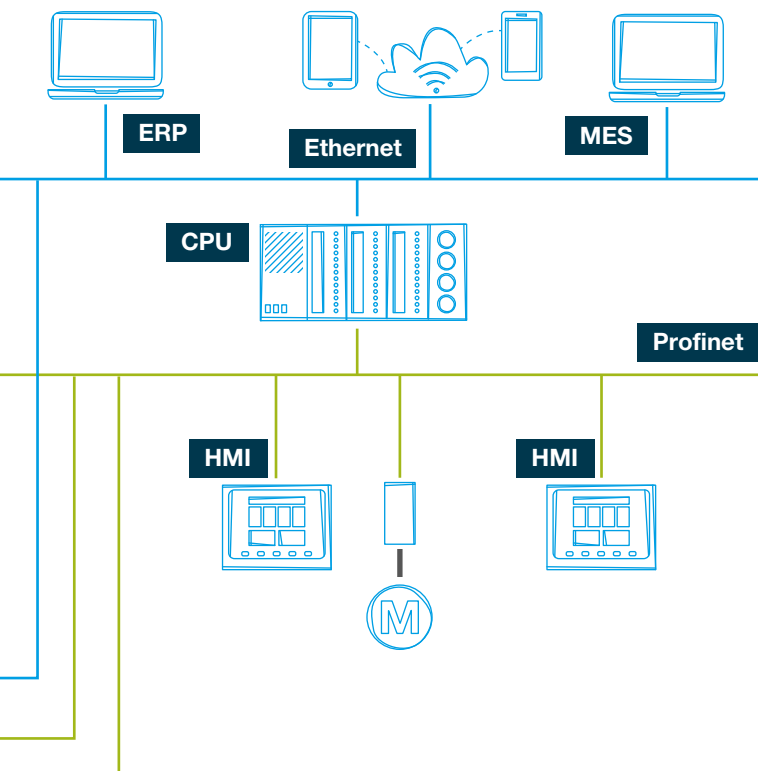

The intelligent CPC20 **ControlPlex**® system protects your DC 24 V power distribution against damage caused by overload and short circuit. The basis is the modular terminal block system module 18plus. The ESX60D electronic circuit protector completes the system. It continuously records the load current and the load voltage of the system. The CPC20 bus controller collects all measuring values and forwards them to the connected control systems via PROFINET or EtherNet/IP. The system operator can continuously monitor his power distribution system and detect changes or aberrations at an early stage.

The CPC20 **ControlPlex**® system system prevents unintended downtimes, improves system transparency and stabilises the production process with regard to condition monitoring. Quality of the produced goods and system availability are significantly improved.

18plus module



Description

The intelligent 18plus **ControlPlex**[®] power distribution system is a compact wiring solution for all load and signal lines of the DC 24 V control voltage. It includes a complete mounting and power distribution system for DIN rail mounting which, together with the supply rails, includes a fully-fledged 80 A potential distribution of the DC 24 V control voltage without the need for additional connection terminals and connecting cables.

Combined with the CPC20, you can connect and communicate with up to 32 double-channel ESX60D electronic circuit breakers.

ESX60D



Description

The ESX60D is a double-channel and communication-capable electronic circuit protector, forming an intelligent power distribution system with the CPC20 bus controller and the 18plus **ControlPlex**[®] system. The ESX60D transmits status and measuring values to the superordinate control unit. Thanks to its slim width of only 12.5 mm and its parametrisation it is suitable for a wide range of applications.

- Space-saving design
- Continuous data logging
- Automatic parametrisation
- Reduced stock keeping

CPC20



Description

The CPC20 bus controller is the central communication module of the CPC20 **ControlPlex**[®] systems. The CPC20 allows communication with up to 32 double channel ESX60D electronic circuit protectors. Their status and their load voltage can be imported, the devices can be controlled and parametrised.

- Separate power supply
- USB service interface, **ELBus**[®] Extended, JSON
- Integral web server
- Field bus connection



Technical data

Mounting	DIN rail
max. rated voltage	DC +24 V
Number of channels	2 x 16 modules (2 x 32 channels)
max. rated current of supply	80 A
max. rated current of loads	20 A
Ambient temperature	-25 °C ... +60 °C
For more information please visit	www.global.e-t-a.com/p4472

18plus module Dimensional drawing

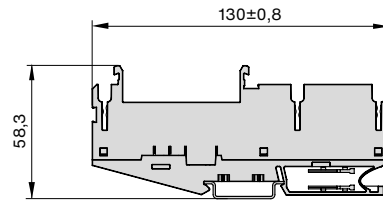

Technical data

Mounting	ControlPlex ® 18plus module
Rated voltage	DC 24 V
Rated current	adjustable between 1A ... 10A
Channels per device	2
Current limitation	Typically 1.4 – 1.8 x I _N
Ambient temperature	-25 °C ... +60 °C
For more information please visit	www.global.e-t-a.com/p6646

ESX60D Dimensional drawing

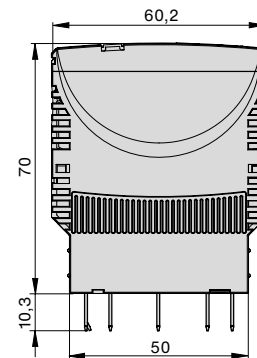

Technical data

Mounting method	DIN rail
Rated voltage	DC 24 V
Rated current	typ. = 160 mA (with 1 x Ethernet and 2 x PROFINET)
Ambient temperature	0 °C ... +60 °C
For more information please visit	www.global.e-t-a.com/c17653

CPC20 Dimensional drawing

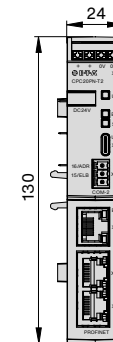



Find more information about the *ControlPlex*[®] Rack here: www.global.e-t-a.com/c14977

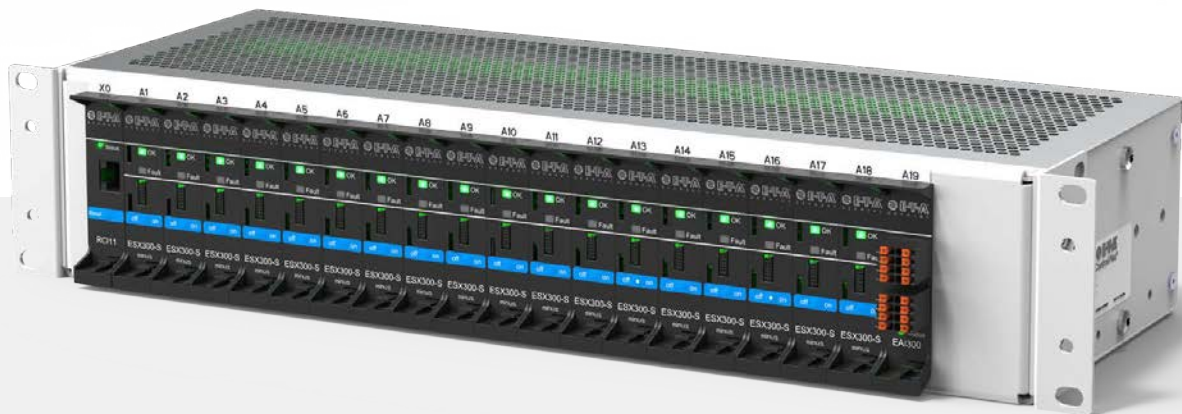

Power distribution



Integration of sensors



**Overcurrent protection
Active current limitation**



Remote control

ControlPlex® Rack

Reliable – precise – smart

ControlPlex® Rack is the intelligent complete system for power distribution and overcurrent protection, combined with smart control and monitoring technology. The system is specifically designed for the selective protection of minus or plus supplied systems.

Successful applications in many markets

- Power engineering: communications systems, such as control and supply of high voltage networks
- Datacentres: Control and supply of servers
- Telecommunications: Control and supply of system cabinets

Technology

Major applications are telecommunication technology systems, both in the negative (DC -48 V or DC -60 V) and in the positive voltage range (DC 24 V, 48 V, 60 V) at different current ratings. The **ControlPlex®** Rack series does not only provide compact power distribution (including safety, transparency, space savings, redundancy and selectivity), it also connects the central communication terminals to the customer's control system.

System components

- PDB-CP – a standardised **Power-D-Box®** with bus board (for plug-in type circuit protectors and control interface modules), modular extension of the number of channels as well as transparent cable management
- ESX300-S – bus-capable electronic circuit protector, hot-swappable, selective precise load disconnection and extended local error display via LED.
- RCI11 – Remote Control Interface for early detection of failures through continuous recording of measuring data. It provides increased system availability and reduces maintenance time on site, e.g. through manual or web-based remote control and monitoring.
- RSI10 – Remote Signalling Interface for provision of potential-free contacts.
- EAI – External Alarm Interface can additionally include external encoder signals into the alarm protocol.

Do you have additional requirements? Our experts will design a suitable system solution for you.



RSI10

EAI300

RCI11

ESX300-S



Remote configuration



Remote monitoring

Our performance profile – your benefits

- Reduced fire hazard through precise, selective failure disconnection
- System stability in the event of a short circuit through avoidance of voltage dips
- Flexibility through hot-swappable components
- Reduced start-up times through plug-in type (application-specific) load terminals and error minimisation through extended display functions
- Reduced maintenance time through measuring data recording and automation via extendable control interface (optional)

Examples for customer-specific configurations of the **ControlPlex®** Rack, e.g. through a wide range of options for supply and load connections.

Power-D-Box® CP



Description

The CP 2HU **Power-D-Box®** can be fitted with ESX300-S plug-in electronic circuit protectors with different current ratings. The signalling and the conduits are integrated in a compact metal enclosure, protected against brush contact so that live parts cannot be touched. Connection is realised via screw terminals or high-current SUB-D connectors. Available options include back-up fuses, single or redundant circuits, customer-specific marking etc.

Typical applications:

- Power engineering
- Telecommunications
- Datacom

ESX300-S minus/ESX300-S plus

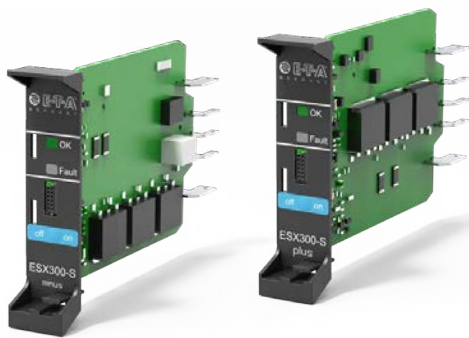

Description

The electronic **ESX300-S minus/ESX300-S plus** circuit protector is designed for systems, in which the minus or plus pole is protected. Overcurrent and short circuit protection are realised by means of electronic current limitation and disconnection and reliably prevent the destruction of electronic sub-assemblies and load lines.

The electronic current limitation prevents high currents from flowing in the event of a short circuit, causing an undesirable voltage dip.

EAI300



Description

In combination with the RCI11, the **EAI300** external alarm interface enables external sensor data and external alarm transmitters to be recorded and alarmed on the management system. It includes e.g. additional monitoring and display of door contacts, fire alarm boxes or temperature sensors in the engineering room. It means best possible system transparency and fast intervention in the event of alarms. Thanks to programmable logical links, operating conditions of the ESX300-S can be connected with external encoder signals, allowing automatic switching operations.

RCI11/RSI10



Description

The **RCI11** Remote Control Interface enables remote control and monitoring of the system and its connected loads, reducing maintenance costs and providing maximum transparency. It integrates the **ControlPlex® Rack** system into the network environment and into the company's centralised management system. It can request, cache and transfer individual measuring data, status conditions and error messages of the ESX300-S to the superordinate control unit.

The **RSI10** Remote Signalling Interface ensures reliable fault detection via potential-free contact.



Technical data

Rated voltage	DC -48 V, DC -60 V DC +24 V, DC +48 V, DC +60 V
Rated current	Total max. 200 A Single load max. 30 A
Number of load channels	1 x 19 2 x 9
Cable cross sections	Supply max. 50 mm ² Load max. 10 mm ²
For more information please visit	www.global.e-t-a.com/p6363

Power-D-Box® CP Dimensional drawing

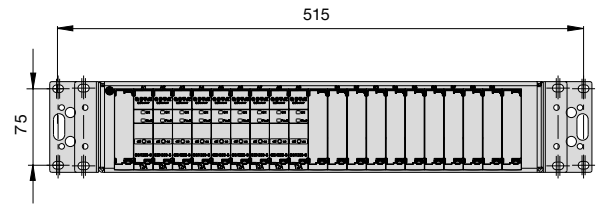

Technical data

Rated voltage	Minus: DC -48 V, DC -60 V Plus: DC +24 V, DC +48 V, DC +60 V
Rated current	max. 24 A
Trip current	typically 1.2 x I _N
Ambient temperature	-20 °C ... +60 °C
For more information please visit	www.global.e-t-a.com/p4418 (Minus) www.global.e-t-a.com/p6380 (Plus)

ESX300-S Dimensional drawing

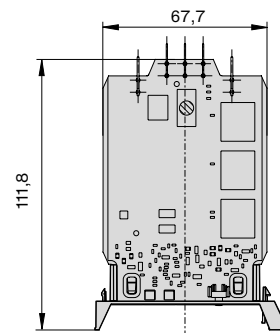

Technical data

Rated voltage	DC +20 V ... +75 V typically 40 mA at DC 48 V
Total current	8 x (physical isolation)
Communication	1 x (physical isolation)
Ambient temperature	2 x (potential-free break contact)
For more information please visit	www.global.e-t-a.com/p6362

EAI300 Dimensional drawing

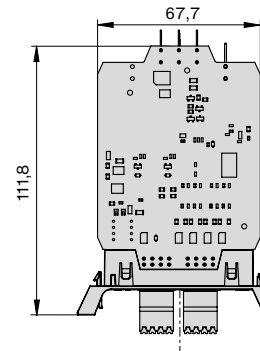

Technical data

Rated voltage	DC 20 V ... DC 75 V
Current consumption	RCI11: typ. 80 mA
Protocol support	SNMP, SSH, HTTP/HTTPS, NTP, DHCP (RCI11)
Ambient temperature	-20 ... +60 °C
For more information please visit	www.global.e-t-a.com/p6361 www.global.e-t-a.com/p6352

RCI11 Dimensional drawing example

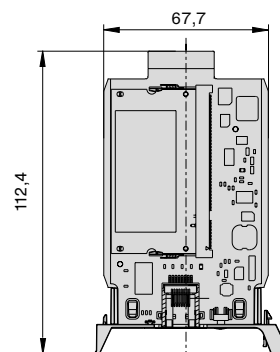

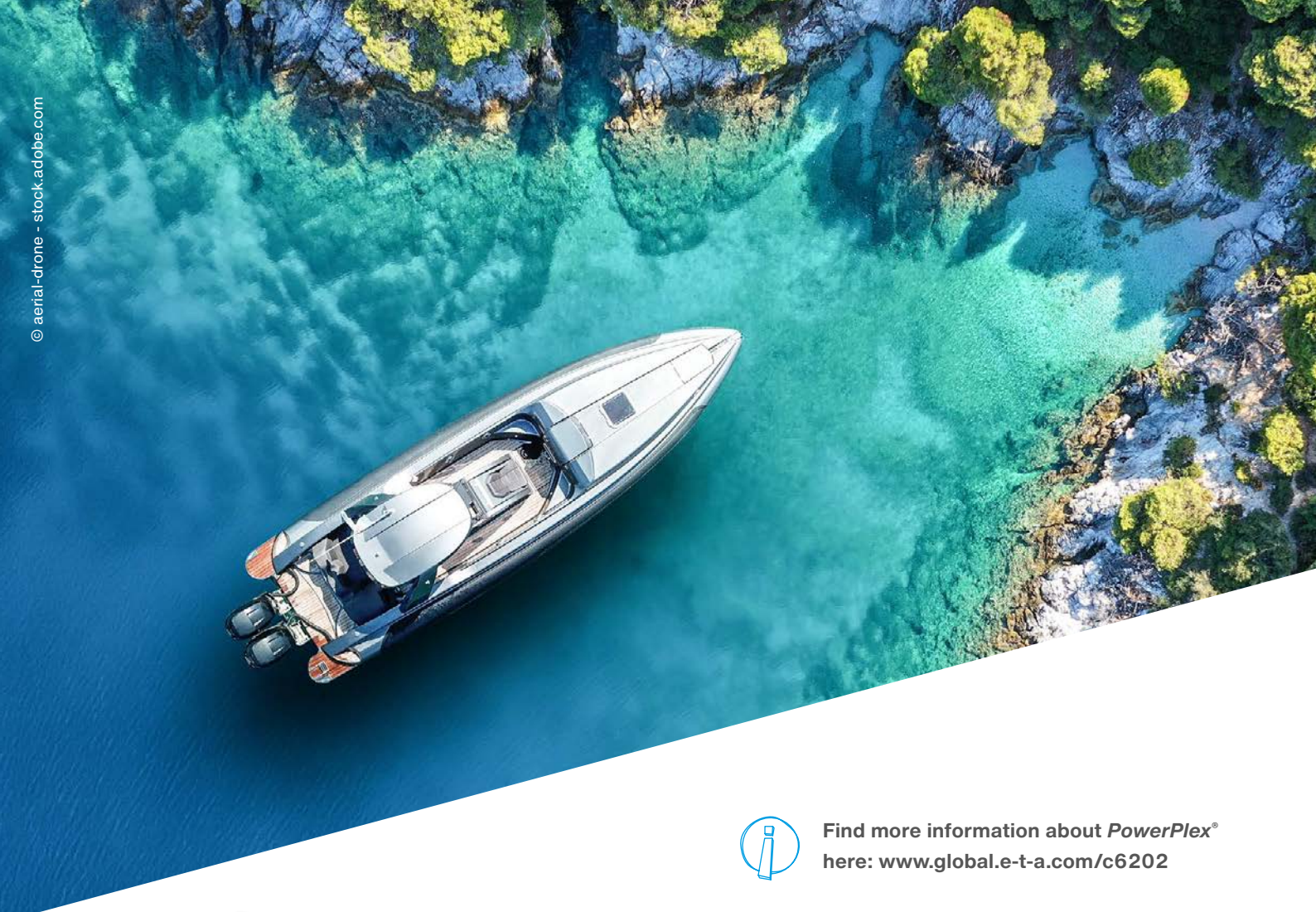

Find more information about **PowerPlex®** here: www.global.e-t-a.com/c6202



Marine application examples

- Monitoring of fuel, fresh water and waste water tanks
- Bilge pump control and monitoring
- Air conditioning control
- On-board / off-shore scenarios
- Light control

Application examples Mobile homes / Caravans

- Tank monitoring of fresh water and waste water
- Heater control
- Control of step treads or cab beds
- Battery monitoring
- Light control

Individual user interfaces:
Boats, mobile homes, caravans

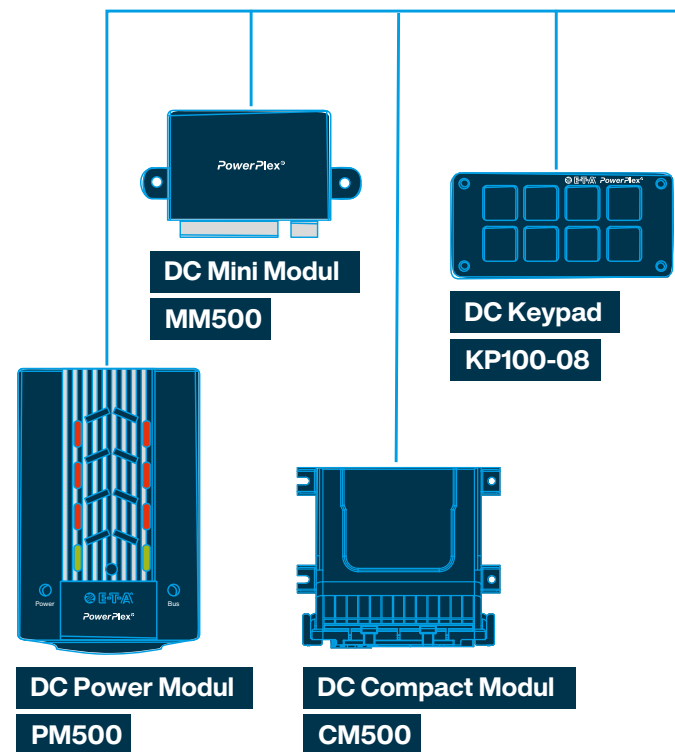

PowerPlex® SYSTEMS

Efficient engineering - convenient connection and automation

A general increase in automation technology has spread over all industrial areas. Intelligent networks offer lots of new options for on-board electrical systems in boats and mobile homes. **PowerPlex®** is E-T-A's answer to this development.

Modular, flexible, customised

A wide range of DC and AC control modules and different operating devices form a comprehensive **PowerPlex®** product group for the realisation of intelligent on-board electrical systems. The system scope is a direct result of the vehicle specifications and your individual control and automation requirements. They are realised and programmed by means of the configuration. The communication of the **PowerPlex®** products is done via an SAE J1939-compliant CAN-Bus, which reliably transmits all relevant data even in critical situations. Our goal is a smooth integration of all **PowerPlex®** products. A **PowerPlex®** system solution can be quickly installed and put into operation, and it can flexibly be extended. Any subsequent customer requests can be implemented independently at any time.

Convenient, safe and reliable

Smart on-board engineering not only facilitates operation. It also helps save energy and increases safety on board by specifically adjusted safety management functions.

PowerPlex® monitors, informs and alerts the user about malfunctions of the installed on-board electrical system. This guarantees smooth operation and the availability of functionally relevant components. The E-T-A **PowerPlex®** system can be configured, adjusted and maintained worldwide by your or our specialists via remote maintenance. This helps minimise breakdowns and maintenance downtimes and the resulting costs.

Visualisation and operator convenience

A clear visual display of operating conditions and command processing provides convenient and reliable operation. We offer a wide range of **PowerPlex®**-specific operating concepts – from keypads to customised user interfaces for touch displays up to mobile devices such as smart phones or tablets. Instead of getting out of bed to turn the air condition down, you simply pick up your smart phone.

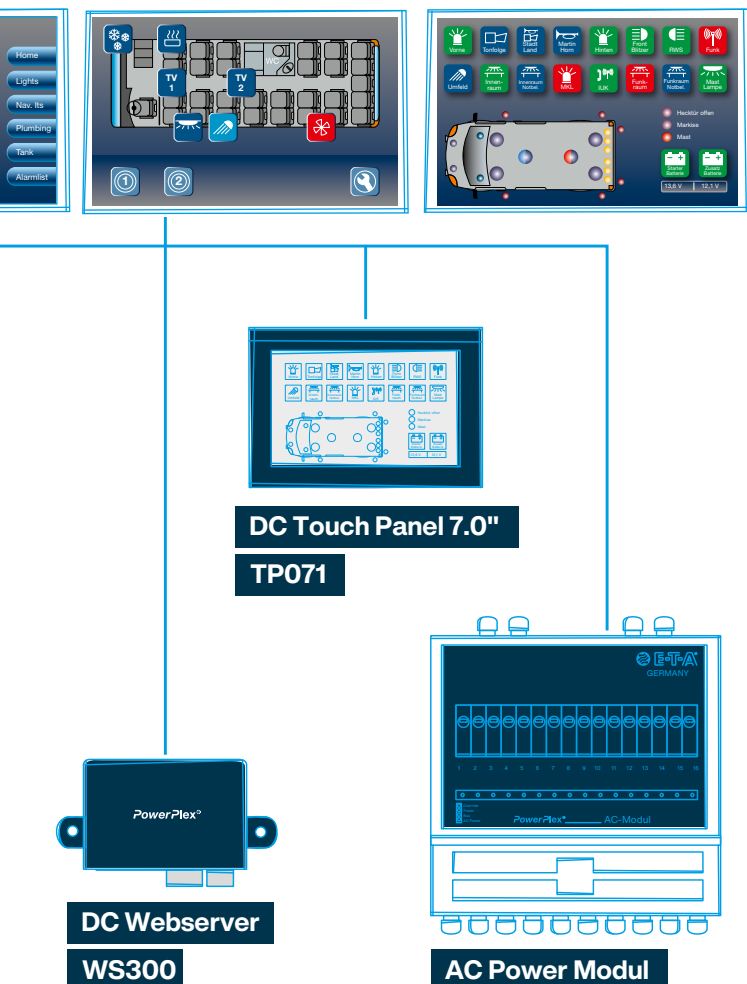

An all-connecting network. Lights, heating, air con, pumps and more. Convenient and user-friendly control by smart phone or tablet.

PowerPlex® reliably and precisely connects, regulates, controls and monitors all kinds of electrical loads, switches and sensors via CAN. It controls status indications, operating conditions and execution of commands. Various alarm functions inform the user about undesired system conditions of the electrical system. Most of them can be remedied simply with the touch of a button and can also be reviewed by looking at the alarm history. Save time and costs during system planning and wiring. Come and see for yourself – the potentials held by **PowerPlex®** will convince you.



Description

The **PowerPlex®** HMI devices enable convenient monitoring and intuitive operation. Visualise status, alarm or error messages. Choose your favourites for your **PowerPlex®** application from various keypads and touch displays. Do you have a special visualisation request? The **PowerPlex®** Touch PC software helps you create individual user interfaces and integrate any Windows-based touch PC into the system.

Typical applications:

- Leisure boats
- Mobile homes
- Work boats
- Caravans



Description

The **PowerPlex®** modules are intelligent control units for DC and AC applications, which can be used alone or in combination. Depending on the number of the required inputs and outputs and the complexity of the control jobs, you can select the system components you need. Programming will be done according to your individual automation specifications. Within a single **PowerPlex®** system, new modules replacing previous devices are automatically identified and configured via the neighbouring module.

Typical applications:

- Leisure boats
- Mobile homes
- Work boats
- Caravans



Description

The **PowerPlex®** configuration software is intuitive and easy to understand. No programming expertise is required. The user can define, save and revise individual configurations regarding power distribution, control and monitoring.

The »intelligence« of the configuration is transmitted to the **PowerPlex®** components via CAN bus. Your electrical installation will be completed fast and professionally. All existing configurations from other projects can be uploaded at any time and then be revised and saved.

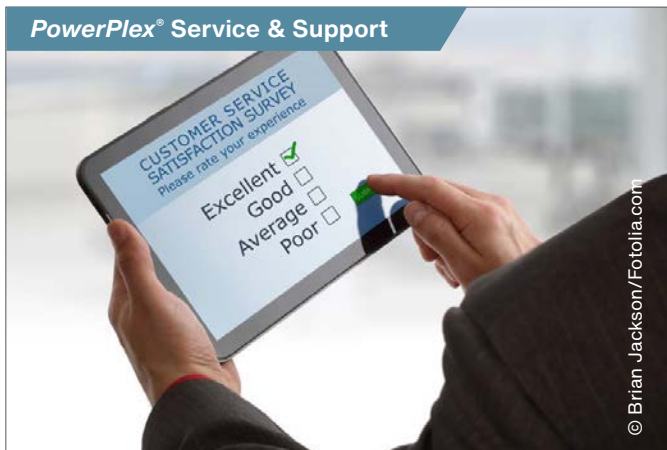

Description

Our specialists will support you with any services you require regarding product, system or application. We help you choose suitable **PowerPlex®** components and support you with technical questions during system planning, installation and commissioning. Many things can easily and quickly be clarified on the phone or via remote maintenance without having to be on site.

Upon request we can provide you with a complete system configuration and tailor-made user interfaces. We will be happy to provide you with comprehensive product training on our **PowerPlex®** system.



Technical data

Rated voltage	DC 12 V DC 24 V AC 230 V
Approvals	product-specific: KBA
For more information please visit	www.global.e-t-a.com/c6309

TP071 Dimensional drawing example

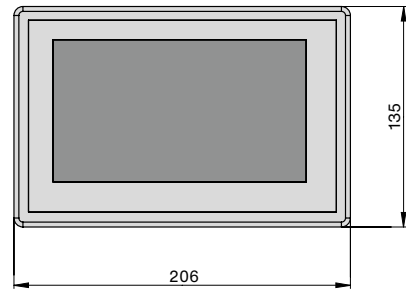

Technical data

Rated voltage	DC 12 V DC 24 V AC 120 V AC 230 V
Approvals	product-specific: GL, LR, KBA
For more information please visit	www.global.e-t-a.com/c6309

PM500 Dimensional drawing example

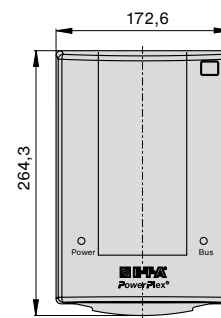

Technical data

For more information please visit	www.global.e-t-a.com/c6309
--	--

Technical data

For more information please visit	www.global.e-t-a.com/c6309
--	--



Find more information about All-in-one here:
www.global.e-t-a.com/c20484

E-BOX Easy Set 18 A



Description

The E-BOX is the central power unit for mobile homes and campervans. It combines charging unit, charging booster, DC 12 V and AC 230 V distribution with fuses as well as control and monitoring functions - all in one compact system. The touch panel can be used to control electrical functions and read the tank levels and battery status. Solar systems can also be easily integrated. Compatible with lead, AGM, gel and LiFePO4 batteries.

- Typical applications:**
- Camper Vans
 - Urban Camper Vans
 - Panel vans

E-BOX Easy Set Panel



Description

The touch panel is the user interface to the E-BOX. It can be used to switch loads and indicate the battery status and tank levels – at one glance.

Customised designs and adaptations possible upon request.

- Typical applications:**
- Camper Vans
 - Urban Camper Vans
 - Panel vans

E-BOX EASY SET

Power distribution system with charging and booster function

With the E-BOX Easy Set, E-T-A offers a compact solution for power distribution and control in mobile homes or camper vans. After installation, the preconfigured system is ready for immediate use and combines power distribution, charging function and control in a well-designed package.

Compact, well-designed, ready for immediate use

At the centre is the E-BOX – an analogue power distribution system with integrated charging unit, charging booster as well as DC 12 V and AC 230 V distribution including protection. All connected loads are reliably supplied with energy. Via the AES signal of a solar controller, the solar charge can be fed directly into the batteries.

The E-BOX is compatible with all common battery types: Lead-acid, AGM, gel and LiFePO4 with integrated battery management system (BMS). It does not only protect the power supply to the living space, it also performs the automatic switching and charging control during driving operation, mains connection or solar power supply.

Controlling, monitoring, indicating

The D203 touch panel included in the set can be used to conveniently control electrical loads in the living area. It also reliably indicates the charge status of the batteries and tank levels of fresh and waste water tanks. As an option, temperature values can also be measured via sensors – for a complete overview of all relevant on-board functions.

Technical data

Rated voltage	DC12V / AC 230V
Charging current	max. 18A
Recommended battery capacity	min. 50Ah, max. 200Ah
Operating temperature range	-20 ... +60°C
For more information please visit	www.global.e-t-a.com/p6814

Technical data

Rated voltage	DC12V
Quiescent current	Typical 7 mA at DC 12 V
IP code	IP53, from the front
Operating temperature range	-20 ... +60°C
For more information please visit	www.global.e-t-a.com/p6814

E-Box system Dimensional drawing

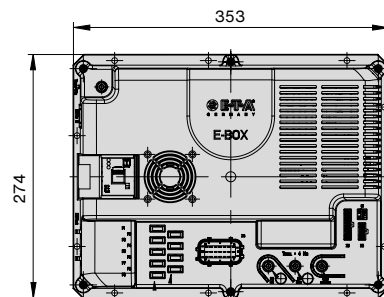

Panel Dimensional drawing

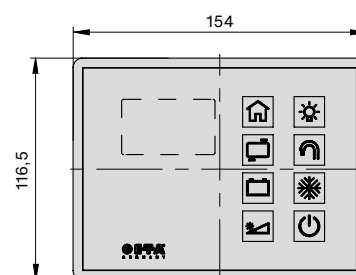

AROUND THE WORLD – PRODUCTION AND SALES

Production sites

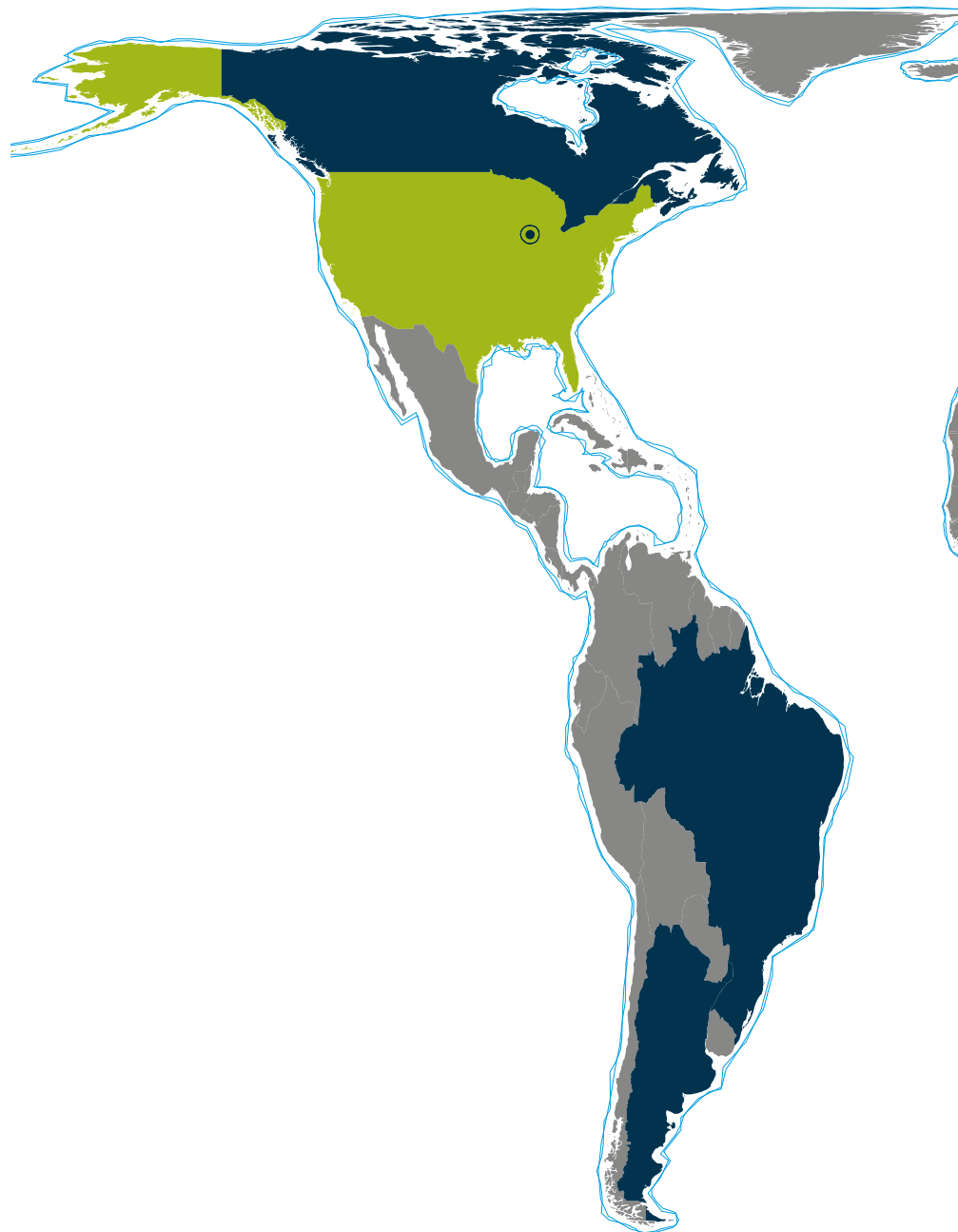

You can find information about
our contact persons
worldwide here:
www.e-t-a.de/contact



Our E-T-A sales subsidiaries

Australia (2005)	Italy (1991)	Singapore (1997)
Benelux (1983)	Japan (1994)	Spain (1987)
China (2005)	Korea (2016)	Thailand (2006)
France (1991)	Malaysia (2009)	UK (1976)
Indonesia (2007)	Austria (1989)	USA (1955)

E-T-A Representative offices

Argentina	New Zealand	Slovenia
Brazil	Norway	South Africa
Denmark	Poland	Czech Republic
Finland	Portugal	Turkey
India	Sweden	Ukraine
Israel	Switzerland	Hungary
Canada	Slovakia	

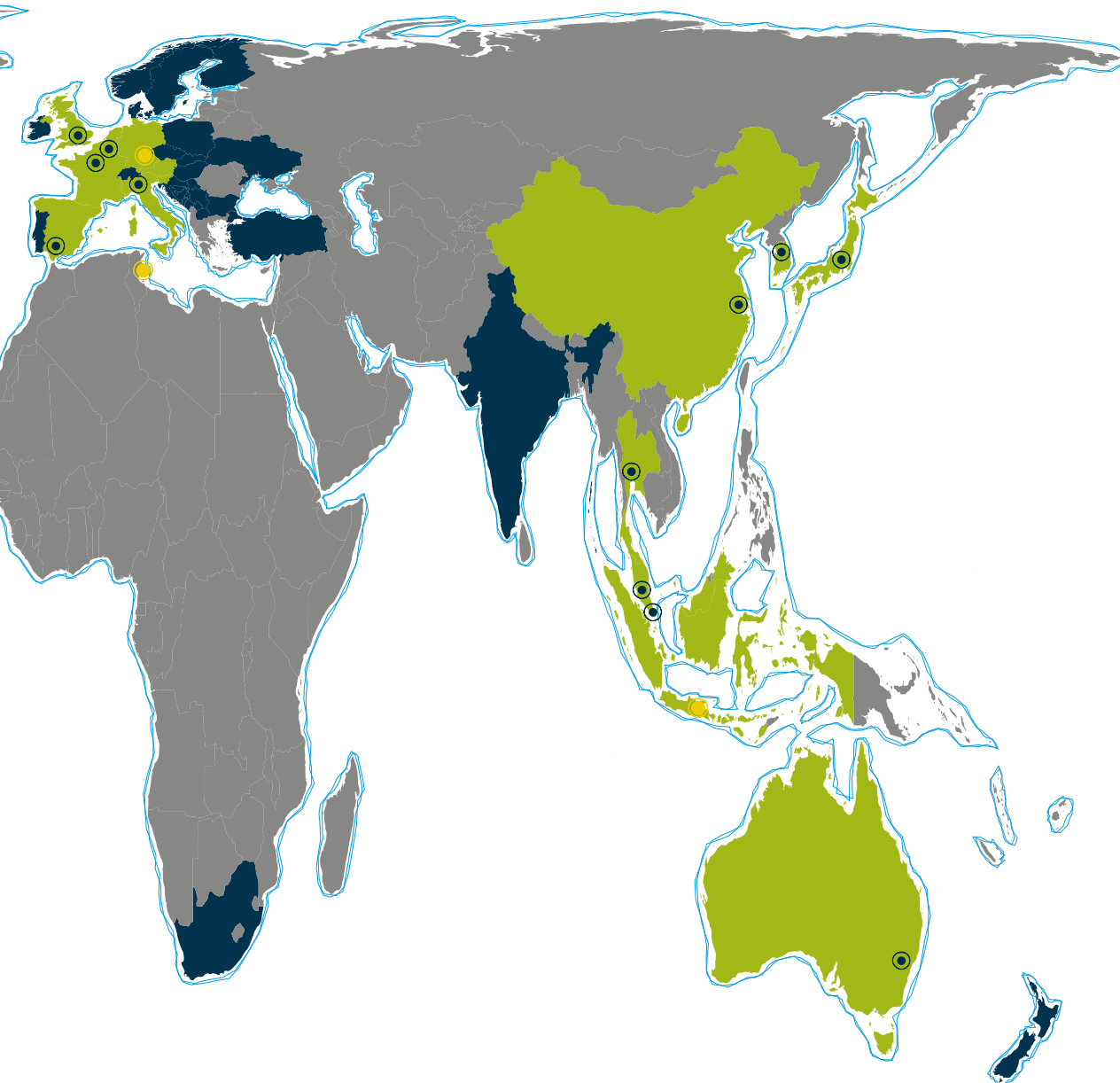

E-T-A Elektrotechnische Apparate GmbH

Industriestraße 2-8

90518 Altdorf

Tel. +49 9187 10-0

Fax +49 9187 10-397

E-Mail: info@e-t-a.de

www.global.e-t-a.com