



TeSys™ island

Components for connected
load management system
Catalog 2023



se.com/tesys

Life Is On

Schneider
Electric

Legal Information

The information provided in this Catalog contains description of Schneider Electric products, solutions and services (“Offer”) with technical specifications and technical characteristics of the performance of the corresponding Offer.

The content of this document is subject to revision at any time without notice due to continued progress in methodology, design and manufacturing.

To the extent permitted by applicable law, no responsibility or liability is assumed by Schneider Electric and its subsidiaries for any type of damages arising out of or in connection with (i) informational content of this Catalog not conforming with or exceeding the technical specifications, or (ii) any error contained in this Catalog, or (iii) any use, decision, act or omission made or taken on basis of or in reliance on any information contained or referred to in this Catalog.

SCHNEIDER ELECTRIC MAKES NO WARRANTY OR REPRESENTATION OF ANY KIND, WHETHER EXPRESS OR IMPLIED, AS TO WHETHER THIS CATALOG OR ANY INFORMATION CONTAINED THEREIN SUCH AS PRODUCTS AND SERVICES WILL MEET REQUIREMENTS, EXPECTATIONS OR PURPOSE OF ANY PERSON MAKING USE THEREOF.

Schneider Electric brand and any trademarks of Schneider Electric and its subsidiaries referred to in this Catalog are property of Schneider Electric or its subsidiaries. All other brands are trademarks of their respective owners.

This Catalog and its content are protected under applicable copyright laws and provided for informative use only. No part of this Catalog may be reproduced or transmitted in any form or by any means (electronic, mechanical, photocopying, recording, or otherwise), for any purpose, without the prior written permission of Schneider Electric.

Copyright, intellectual, and all other proprietary rights in the content of this Catalog (including but not limited to software, audio, video, text, and photographs) rests with Schneider Electric or its licensors. All rights in such content not expressly granted herein are reserved. No rights of any kind are licensed or assigned or shall otherwise pass to persons accessing this information.

Trademarks

QR Code is a registered trademark of DENSO WAVE INCORPORATED in Japan and other countries.

TeSys™ island

Island Concept

TeSys™ island is an innovative digital load management solution, providing data for higher machine efficiency and ease of servicing, and allowing faster time to market.

TeSys island is a modular, multifunctional system providing integrated functions inside an automation architecture, primarily for the direct control and management of low-voltage loads. After commissioning, TeSys island can switch, help protect, and manage motors and other electrical loads up to 37 kW installed in an electrical control panel.

This system is designed around the concept of TeSys avatars. These avatars:

- are the functional object representing a logical function of the physical module with pre-defined logic
- determine the configuration of the island.

The logical aspects of the island are managed with software tools, covering all phases of product and application lifecycle: design, engineering, commissioning, operation, and maintenance.

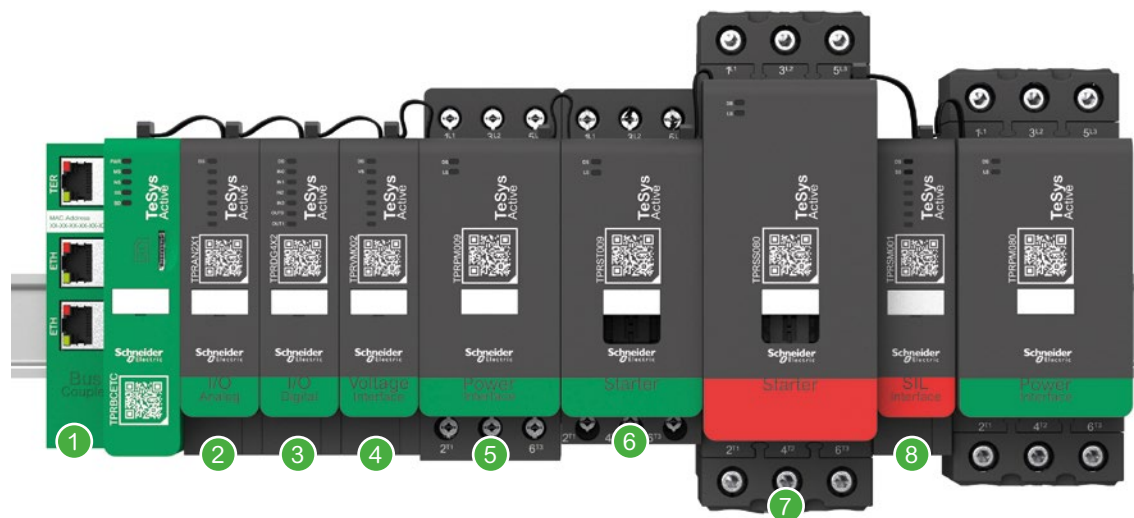

- | | |
|----------------------------|--------------------------|
| 1 Bus Coupler | 5 Power interface module |
| 2 Analog I/O module | 6 Standard Starter |
| 3 Digital I/O module | 7 SIL Starter |
| 4 Voltage interface module | 8 SIL interface module |

The physical island consists of a set of devices installed on a single DIN rail controlling loads, monitoring data, diagnostics information and connected together with a ribbon cable providing the internal communication between modules.

The external communication with the automation environment is made via a single coupler module, and the island is seen as a single node on the network. The other modules include starters, power interface modules, analog and digital I/O modules, voltage interface modules, and SIL interface modules, covering a wide range of operational functions.

General contents

TeSys island

TeSys avatarp. 6

Library: description and applications
Composition in modules
Product references

A

Module Descriptions / Specificationsp. 9

TeSys island Bus Couplers
TeSys island Power Interface Modules
TeSys island Standard Starters
TeSys island SIL Starters
TeSys island SIL Interface Module
TeSys island Digital I/O module
TeSys island Analog I/O module
TeSys island Voltage interface module
TeSys island assembly kits
Related documentation

B

Coordination tablesp. 43

Protection Components / Starters – Coordination – IEC
Protection Components / Starters – SCCR Ratings – UL

C

Related documentationp. 53

TeSys avatar

Library

Avatar descriptions and applications

Avatars			Functions	
ID	Name	Description	Electrical & load protection & control	SIL Stop function ⁽¹⁾
A001	Pump	To manage a pump	●	
A002	Conveyor One Direction	To manage a conveyor in one direction	●	
A003	Conveyor One Direction - SIL Stop, W. Cat 1/2 ⁽¹⁾	To manage a conveyor in one direction, with SIL Stop function compliance for wiring category 1 and category 2	●	●
A004	Conveyor Two Directions	To manage a conveyor in two directions	●	
A005	Conveyor Two Directions - SIL Stop, W. Cat 1/2 ⁽¹⁾	To manage a conveyor in two directions, with SIL Stop function compliance for wiring category 1 and category 2	●	●
D001	Switch	To make or break a power line in an electrical circuit		
D002	Switch - SIL Stop, W. Cat 1/2 ⁽¹⁾	To make or break a power line in an electrical circuit with SIL Stop function compliance for wiring category 1 and category 2		●
D004	Digital I/O	To provide control of 2 digital outputs and status of 4 digital inputs		
D005	Analog I/O	To provide control of 1 analog output and status of 2 analog inputs		
D006	Switch - SIL Stop, W. Cat 3/4 ⁽¹⁾	To make or break a power line in an electrical circuit with SIL Stop function compliance for wiring category 3 and category 4		●
L001	Power Interface w/o I/O (measure)	To monitor current supplied to an external device, such as a solid-state relay, soft starter, or variable speed drive		
L002	Power Interface with I/O (control)	To monitor current supplied to and to control an external device, such as a solid-state relay, soft starter, or variable speed drive	●	
L003	Motor One Direction	To manage ⁽²⁾ a motor in one direction	●	
L004	Motor One Direction - SIL Stop, W. Cat 1/2 ⁽¹⁾	To manage a motor in one direction, with SIL Stop function compliance for wiring category 1 and category 2	●	●
L006	Motor Two Directions	To manage a motor in two directions (forward and reverse)	●	
L007	Motor Two Directions - SIL Stop, W. Cat 1/2 ⁽¹⁾	To manage a motor in two directions (forward and reverse), with SIL Stop function compliance for wiring category 1 and category 2	●	●
L009	Motor Y/D One Direction	To manage a wye/delta (star/delta) motor in one direction	●	
L010	Motor Y/D Two Directions	To manage a wye/delta (star/delta) motor in two directions (forward and reverse)	●	
L011	Motor Two Speeds	To manage a two-speed motor	●	
L012	Motor Two Speeds - SIL Stop, W. Cat 1/2 ⁽¹⁾	To manage a two-speed motor, with SIL Stop function compliance for wiring category 1 and category 2	●	●
L014	Motor Two Speeds Two Directions	To manage a two-speed motor in two directions (forward and reverse)	●	
L015	Motor Two Speeds Two Directions - SIL Stop, W. Cat 1/2 ⁽¹⁾	To manage a two-speed motor in two directions (forward and reverse), with SIL Stop function compliance for wiring category 1 and category 2	●	●
L017	Resistor	To manage a resistive load	●	
L018	Power Supply	To manage a power supply	●	
L019	Transformer	To manage a transformer	●	
L020	Motor One Direction - SIL Stop, W. Cat 3/4 ⁽¹⁾	To manage a motor in one direction, with SIL Stop function compliance for wiring category 3 and category 4	●	●
L021	Motor Two Directions SIL Stop, W. Cat 3/4 ⁽¹⁾	To manage a motor in two directions, with SIL Stop function compliance for wiring category 3 and category 4	●	●
L022	Motor Two Speed - SIL Stop, W. Cat 3/4 ⁽¹⁾	To manage a two-speed motor, with SIL Stop function compliance for wiring category 3 and category 4	●	●
L023	Motor Two Speeds Two Directions - SIL Stop, W. Cat 3/4 ⁽¹⁾	To manage a two-speed motor in two directions, with SIL Stop function compliance for wiring category 3 and category 4	●	●
S001	System avatar	A required avatar that enables a single point of communication to the island		

(1) Wiring Category 1, Category 2, Category 3 and Category 4 according to ISO 13849.

(2) "Manage" in this context encompasses energizing, controlling, monitoring, diagnosing, and protecting the load.

TeSys avatar

Composition in modules

TeSys island modules



Note: a TeSys island Bus Coupler (BC) must be added to all TeSys island module assemblies.

Avatars composition (TeSys island modules)

Avatar ID / description	Module 1	Module 2	Module 3	Module 4	Optional modules	Assembling kit
A001 Pump	ST	DG			DG, AN	
A002 Conveyor One Direction	ST	DG			DG, AN	
A003 Conveyor One Direction - SIL Stop, W. Cat. 1/2 ⁽¹⁾	SS	DG			DG, AN	K
A004 Conveyor Two Directions	ST	ST	DG	DG	DG, AN	
A005 Conveyor Two Directions - SIL Stop, W. Cat. 1/2 ⁽¹⁾	SS	SS	DG		DG, AN	K
D001 Switch	ST					
D002 Switch - SIL Stop, W. Cat 1/2 ⁽¹⁾	SS ⁽²⁾					
D004 Digital I/O	DG					
D005 Analog I/O	AN					
D006 Switch - SIL Stop, W. Cat 3/4 ⁽¹⁾	SS ⁽²⁾					
L001 Power Interface w/o I/O (measure)	PIM				AN	
L002 Power Interface with I/O (control)	DG	PIM			AN	
L003 Motor One direction	ST				AN	
L004 Motor One Direction - SIL Stop, W. Cat 1/2 ⁽¹⁾	SS ⁽²⁾				AN	
L006 Motor Two Directions	ST	ST			AN	K
L007 Motor Two Directions - SIL Stop, W. Cat 1/2 ⁽¹⁾	SS ⁽²⁾	SS			AN	K
L009 Motor Y/D One Direction	ST	ST	ST		AN	K
L010 Motor Y/D Two Directions	ST	ST	ST	ST	AN	K
L011 Motor Two Speeds	ST	ST			AN	K
L012 Motor Two Speeds - SIL Stop, W. Cat 1/2 ⁽¹⁾	SS ⁽²⁾	SS			AN	K
L014 Motor Two Speeds Two Directions	ST	ST	ST	ST	AN	K
L015 Motor Two Speeds Two Directions - SIL Stop, W. Cat 1/2 ⁽¹⁾	ST ⁽²⁾	ST	SS ⁽²⁾	SS	AN	K
L017 Resistor	ST					
L018 Power Supply	ST					
L019 Transformer	ST					
L020 Motor One Direction - SIL Stop, W. Cat 3/4 ⁽¹⁾	SS ⁽²⁾					
L021 Motor Two Directions - SIL Stop, W. Cat 3/4 ⁽¹⁾	SS ⁽²⁾	SS				
L022 Motor Two Speed - SIL Stop, W. Cat 3/4 ⁽¹⁾	SS ⁽²⁾	SS			AN	K
L023 Motor Two Speed Two Directions - SIL Stop, W. Cat 3/4 ⁽¹⁾	SS ⁽²⁾	ST	SS ⁽²⁾	SS	AN	K
S001 System avatar	BC					

(1) Wiring Category 1, Category 2, Category 3 and Category 4 according to ISO 13849.

(2) One SIM is needed with every SIL group in an island, even if the group is composed of several SS modules.

TeSys island

Product references

Designation		Product commercial reference	Page
TeSys island components			
Standard Starter	9 A (AC-3)	TPRST009	18, 19, 20
	25 A (AC-3)	TPRST025	18, 19, 20
	38 A (AC-3)	TPRST038	18, 19, 20
	65 A (AC-3)	TPRST065	18, 19, 20
	66 A (AC-3) - 80 A (AC-1)	TPRST080	18, 19, 20
SIL Starter	9 A (AC-3)	TPRSS009	22, 23, 24
	25 A (AC-3)	TPRSS025	22, 23, 24
	38 A (AC-3)	TPRSS038	22, 23, 24
	65 A (AC-3)	TPRSS065	22, 23, 24
	66 A (AC-3) - 80 A (AC-1)	TPRSS080	22, 23, 24
Power interface module	9 A (AC-3)	TPRPM009	15, 16
	38 A (AC-3)	TPRPM038	15, 16
	80 A (AC-3)	TPRPM080	15, 16
Voltage interface module		TPRVM001	37, 38
SIL interface module		TPRSM001	26, 27
Digital I/O module	(4 input - 2 output)	TPRDG4X2	30, 31
Analog I/O module	(2 input - 1 output)	TPRAN2X1	33, 34, 35
Bus Coupler	EtherNet/IP - Modbus TCP	TPRBCEIP	10, 11
	PROFINET	TPRBCPFN	10, 12
	PROFIBUS	TPRBCPF B	10, 13
Assembly and Wiring Kits			
Kit for reversing starter application	for 9, 25, 38 A (size 1 and 2) starters	LAD9R1	41
	for 65, 80 A (size 3) starters	LAD9R3	41
Jumper bar 3-pole for Star Delta application	for 9, 25, 38 A (size 1 and 2) starters	LAD9P3	41
	for 65, 80 A (size 3) starters, a hazard sticker is provided	LAD9SD3S	41

Module

Descriptions and Specifications

TeSys island Bus Couplers

Introduction	p. 10
Specifications	p. 11
Dimensions	p. 14

TeSys island Power Interface Modules

Introduction	p. 15
Specifications	p. 16
Dimensions	p. 17

TeSys island Standard Starters

Introduction	p. 19
Specifications	p. 20
Dimensions	p. 21

TeSys island SIL Starters

Introduction	p. 22
Specifications	p. 23
Dimensions	p. 25

TeSys island SIL Interface Module

Introduction	p. 26
Specifications	p. 27
Dimensions	p. 28

TeSys island Digital I/O module

Introduction	p. 30
Specifications	p. 31
Dimensions	p. 32

TeSys island Analog I/O module

Introduction	p. 33
Specifications	p. 34
Dimensions	p. 36

TeSys island Voltage Interface Module

Introduction	p. 37
Specifications	p. 38
Dimensions	p. 39

TeSys island assembly kits

Introduction	p. 40
--------------------	-------



TeSys island Bus Couplers Introduction

Bus Couplers (BC), for communication between the modules and the PLC



TPRBCEIP

TPRBCPFN



TPRBCPFB

A Bus Coupler is always present in the island as the fieldbus communication interface. It controls all other modules of the island.

Main functions

- Communicating with the PLC
- Managing the avatars and their associated modules
- Collecting operational status and diagnostic data from the island's modules
- Communicating with configuration, operation and maintenance digital tools
- Supplying the modules with control power.

The bus coupler is connected

- Upstream to the fieldbus
- Downstream to the island devices with the ribbon cable
- Upstream to the control power supply
- Optionally, through its service port, to a programming tool working with EcoStruxure™ Machine Expert, a single software environment.

For TPRBCEIP and TPRBCPFN, the bus coupler service port and dual port Ethernet switch are located on the same network with the same IP address. All bus couplers are equipped with a micro SD card slot, to allow several upload and backup functions on a micro SD card.

Bus Coupler Features

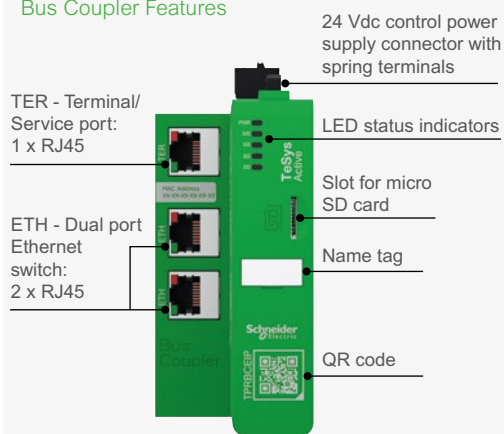

TPRBCEIP

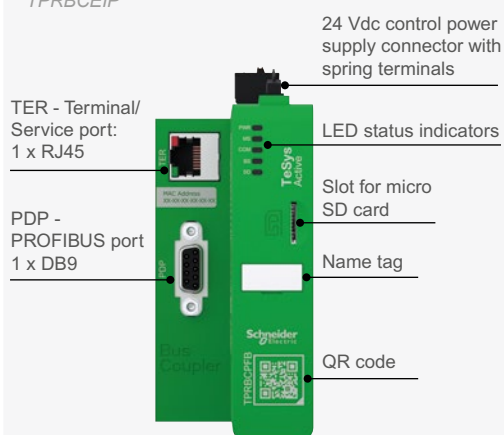

TPRBCPFB

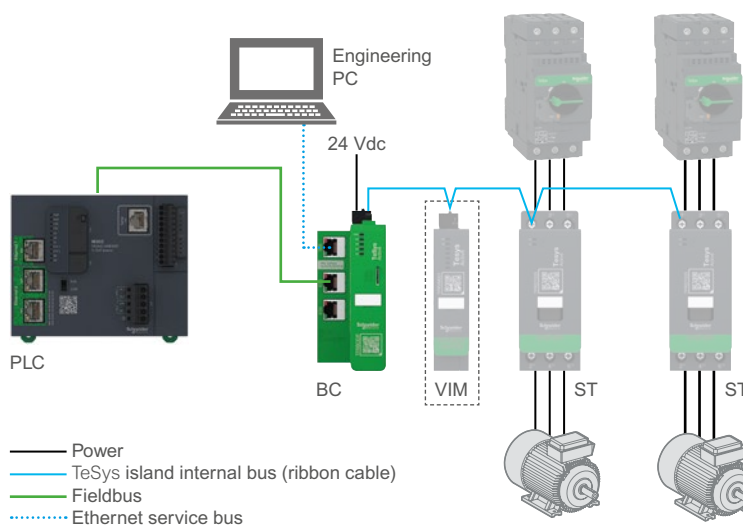

Product commercial information

Designation	Fieldbus protocol	Service bus protocol	Product Reference	Weight (kg)
TeSys island Bus Coupler	EtherNet/IP - Modbus TCP	Ethernet TCP/IP	TPRBCEIP	0.204
	PROFINET	Ethernet TCP/IP	TPRBCPFN	0.204
	PROFIBUS	Ethernet TCP/IP	TPRBCPFB	0.204

TeSys island Bus Couplers

Specifications

Bus Coupler Product Reference		TPRBCEIP
Standards - Certification		
Standards		EN/IEC 61010-02-201, EN/IEC 60947-4-1, UL 61010-02-201, CSA C22.2 No 61010-02-201
Product certification		UL, CSA, EAC
Cybersecurity		Achilles certified - level 2

Functional specifications

Functionalities		Provides communication between a TeSys island and a PLC. Communication management with up to 20 Starters/modules
Software compatibility		Compatible with SoMove , a setup software for PC designed to configure Schneider Electric motor control devices, EcoStruxure™ Machine Expert , a solution software for developing, configuring, and commissioning the entire machine in a single software and EcoStruxure™ Control Expert , a solution software for developing, configuring, and commissioning the Modicon PLC in a single software
1 TER port: for engineering		RJ45 connector for engineering PC - Ethernet TCP/IP
2 ETH ports: for fieldbus		RJ45 connector - EtherNet/IP; Modbus TCP
Exchange mode		Half duplex, full duplex, autonegotiation Ethernet
Communication services		EtherNet/IP adapter, Modbus TCP server, DHCP client, SNMP client, SNTP client, auto MDI/MDX function
External storage / configuration; parameters; Log files		Micro SD memory card (not provided), Micro SD port is provided on TPRBCEIP
Local signaling		<ul style="list-style-type: none"> • Island Power on, 1 green/yellow LED • Module status, 1 green/red LED • Network / fieldbus status, 1 green/red LED • TeSys island internal bus status, 1 green/red LED • Micro SD card status, 1 green/red LED

Environment

Ambient air temperature for storage	°C (°F)	-25...70 (-13...158)
Ambient air temperature for operation	°C (°F)	-10...60 (14...140)
Ambient air humidity for operation	%	5...95
Operating altitude	m (ft)	0...2000 (0...6562) without derating
IP degree of protection		IP20
Pollution degree		2
Protective treatment		TC
Fire resistance	°C (°F)	960 (1760) conforming to UL 94 850 (1562) conforming to IEC 60695-2-1 650 (1202) conforming to IEC 60695-2-12
Vibration resistance	mm	1.5 peak to peak (3...13 Hz) conforming to IEC 60068-2-6 1 gn (13... 200 Hz) conforming to IEC 60068-2-6
Authorised mounting modes		Horizontal and vertical, on 35 mm symmetrical DIN rail
Shock resistance		15 gn (duration = 11 ms) conforming to IEC 60068-2-27
Electromagnetic compatibility		<ul style="list-style-type: none"> • Electrostatic discharge at 8 kV air, 6 kV contact conforming to EN/IEC 61000-4-2 level 3 • Radiated RF fields at 10 V/m conforming to EN/IEC 61000-4-3 level 3 • Fast transient immunity test at 4 kV conforming to EN/IEC 61000-4-4 level 4 • Surges, differential mode at 2 kV conforming to EN/IEC 61000-4-5 level 3 • Surges, common mode at 4 kV conforming to EN/IEC 61000-4-5 level 4

Electrical specifications

Rated supply voltage [Us]	Vdc	24
Supply voltage limits	Vdc	20.7...28.8
Rated current (maximum)	A	3
External fuse rating	A	3 - Fast - Reverse polarity
Power dissipation	W	7

Power connection

Removable spring terminal block	1 rigid cable	mm ² /AWG	2.5 / 14
	1 flexible cable	mm ² /AWG	2.5 / 14
	1 flexible cable with cable end	mm ² /AWG	2.5 / 14

TeSys island Bus Couplers

Specifications (cont.)

Bus Coupler Product Reference		TPRBCPFN
Standards - Certification		
Standards		EN/IEC 61010-02-201, EN/IEC 60947-4-1, UL 61010-02-201, CSA C22.2 No 61010-02-201
Product certification		UL, CSA, EAC, PNO
Cybersecurity		Achilles certified - level 2
Functional specifications		
Functionalities		Provides communication between a TeSys island and a PLC. Communication management with up to 20 Starters/modules
Software compatibility		Compatible with SoMove , a setup software for PC designed to configure Schneider Electric motor control devices
1 TER port: for engineering		RJ45 connector for engineering PC - Ethernet TCP/IP
2 ETH ports: for fieldbus		RJ45 connector - PROFINET
Exchange mode		Half duplex, full duplex, autonegotiation Ethernet
Communication services		PROFINET IO Conformance Class A (CC-A), PROFINET IO Net Load Class 1, DHCP client, SNTP client, auto MDI/MDX function
External storage / configuration; parameters; Log files		Micro SD memory card (not provided), Micro SD port is provided on TPRBCPFN
Local signaling		<ul style="list-style-type: none"> • Island Power on, 1 green/yellow LED • Module status (SF), 1 green/red LED • Network / fieldbus status (BF), 1 green/red LED • TeSys island internal bus status, 1 green/red LED • Micro SD card status, 1 green/red LED
Environment		
Ambient air temperature for storage	°C (°F)	-25...70 (-13...158)
Ambient air temperature for operation	°C (°F)	-10...60 (14...140)
Ambient air humidity for operation	%	5...95
Operating altitude	m (ft)	0...2000 (0...6562) without derating
IP degree of protection		IP20
Pollution degree		2
Protective treatment		TC
Fire resistance	°C (°F)	960 (1760) conforming to UL 94 850 (1562) conforming to IEC 60695-2-1 650 (1202) conforming to IEC 60695-2-12
Vibration resistance	mm	1.5 peak to peak (3...13 Hz) conforming to IEC 60068-2-6 1 gn (13... 200 Hz) conforming to IEC 60068-2-6
Authorised mounting modes		Horizontal and vertical, on 35 mm symmetrical DIN rail
Shock resistance		15 gn (duration = 11 ms) conforming to IEC 60068-2-27
Electromagnetic compatibility		<ul style="list-style-type: none"> • Electrostatic discharge at 8 kV air, 6 kV contact conforming to EN/IEC 61000-4-2 level 3 • Radiated RF fields at 10 V/m conforming to EN/IEC 61000-4-3 level 3 • Fast transient immunity test at 4 kV conforming to EN/IEC 61000-4-4 level 4 • Surges, differential mode at 2 kV conforming to EN/IEC 61000-4-5 level 3 • Surges, common mode at 4 kV conforming to EN/IEC 61000-4-5 level 4
Electrical specifications		
Rated supply voltage [Us]	Vdc	24
Supply voltage limits	Vdc	20.7...28.8
Rated current (maximum)	A	3
External fuse rating	A	3 - Fast - Reverse polarity
Power dissipation	W	7

TeSys island Bus Couplers Specifications (cont.)

Bus Coupler Product Reference		TPRBCPFB
Standards - Certification		
Standards		EN/IEC 61010-02-201, EN/IEC 60947-4-1, UL 61010-02-201, CSA C22.2 No 61010-02-201
Product certification		UL, CSA, EAC, PNO
Cybersecurity		Achilles certified - level 2

Functional specifications

Functionalities		Provides communication between a TeSys island and a PLC. Communication management with up to 20 Starters/modules
Software compatibility		Compatible with SoMove , a setup software for PC designed to configure Schneider Electric motor control devices
1 TER port: for engineering		RJ45 connector for engineering PC - Ethernet TCP/IP
1 DB9 port: for fieldbus		DB9 connector - PROFIBUS
Exchange mode		PROFIBUS
Communication services		<ul style="list-style-type: none"> • On TER port: DHCP client, SNTP client • On DB9 port: Type 3 DP PROFIBUS slave, supporting DP-V0 and DP-V1
External storage / configuration; parameters; Log files		Micro SD memory card (not provided), Micro SD port is provided on TPRBCPFB
Local signaling		<ul style="list-style-type: none"> • Island Power on, 1 green/yellow LED • Module status, 1 green/red LED • Network / fieldbus status, 1 green/red LED • TeSys island internal bus status, 1 green/red LED • Micro SD card status, 1 green/red LED

Environment

Ambient air temperature for storage	°C (°F)	-25...70 (-13...158)
Ambient air temperature for operation	°C (°F)	-10...60 (14...140)
Ambient air humidity for operation	%	5...95
Operating altitude	m (ft)	0...2000 (0...6562) without derating
IP degree of protection		IP20
Pollution degree		2
Protective treatment		TC
Fire resistance	°C (°F)	960 (1760) conforming to UL 94 850 (1562) conforming to IEC 60695-2-1 650 (1202) conforming to IEC 60695-2-12
Vibration resistance	mm	1.5 peak to peak (3...13 Hz) conforming to IEC 60068-2-6 1 gn (13... 200 Hz) conforming to IEC 60068-2-6
Authorised mounting modes		Horizontal and vertical, on 35 mm symmetrical DIN rail
Shock resistance		15 gn (duration = 11 ms) conforming to IEC 60068-2-27
Electromagnetic compatibility		<ul style="list-style-type: none"> • Electrostatic discharge at 8 kV air, 6 kV contact conforming to EN/IEC 61000-4-2 level 3 • Radiated RF fields at 10 V/m conforming to EN/IEC 61000-4-3 level 3 • Fast transient immunity test at 4 kV conforming to EN/IEC 61000-4-4 level 4 • Surges, differential mode at 2 kV conforming to EN/IEC 61000-4-5 level 3 • Surges, common mode at 4 kV conforming to EN/IEC 61000-4-5 level 4

Electrical specifications

Rated supply voltage [Us]	Vdc	24
Supply voltage limits	Vdc	20.7...28.8
Rated current (maximum)	A	3
External fuse rating	A	3 - Fast - Reverse polarity
Power dissipation	W	7

TeSys island Bus Couplers

Dimensions

Bus Coupler: TPRBCEIP, TPRBCPFN, TPRBCPFB*

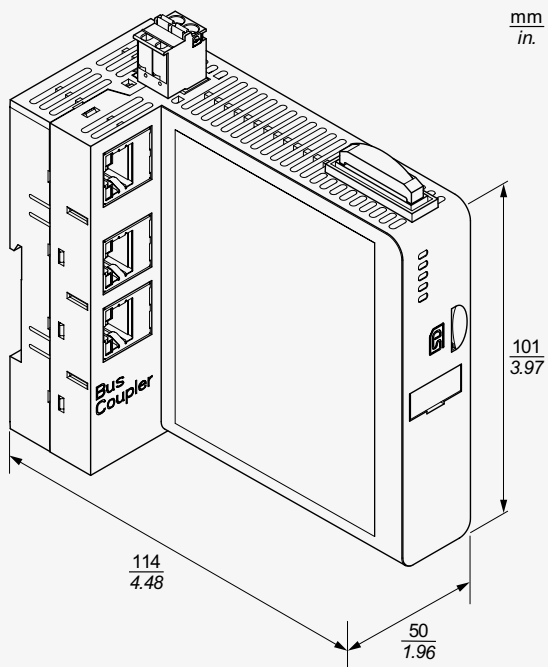

(*) TPRBCPFB not shown, but overall dimensions are similar.

Bus Coupler Spring Terminal Connector



TeSys island Power Interface Modules Introduction

Power Interface Modules (PIMs) for electrical and thermal protection, digital asset management capabilities

A

B

C



TPRPM009 TPRPM038 TPRPM080

A PIM can be associated with an analog I/O device to measure temperature through an external sensor. A PIM can also monitor the current supplied to an external device.

Main functions

- Measure downstream electrical data related to the load
- Provide energy monitoring data when a voltage interface module (VIM) is installed on the island.

The PIMs are connected

- Upstream to a circuit breaker
- Downstream to an external power device like a contactor, soft starter, or solid-state relay.

The PIM communicates with the bus coupler, sending operational data and receiving commands. In this example, a Digital I/O module (DG) is used to control the soft starter.

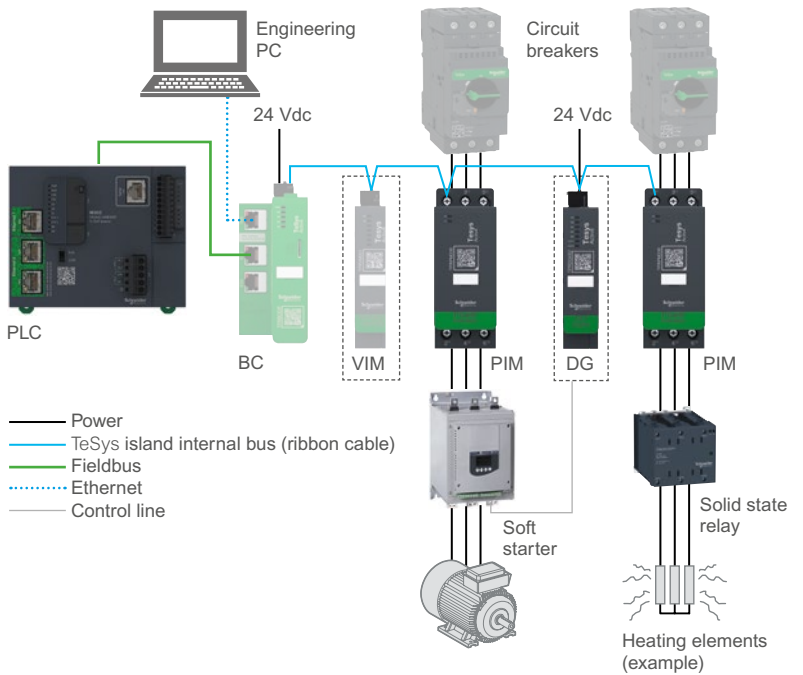
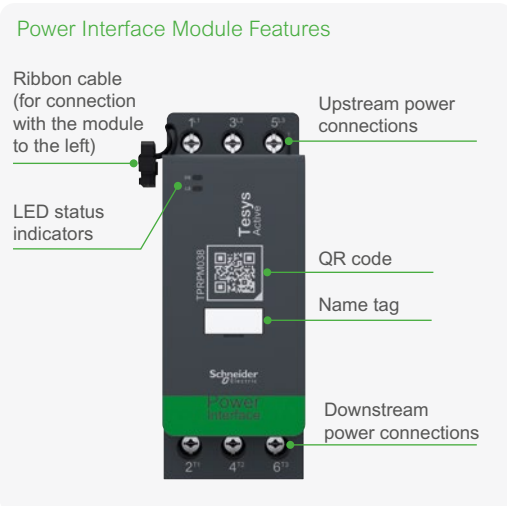

3-Pole PIM Power interface modules

Standard power ratings of 3-phase motors
50-60 Hz in category AC-3
($\theta \leq 60^\circ\text{C}$)

220 V 230 V	380 V 400 V	415 V	440 V	500 V	660 V 690 V	1000 V	460 V 480 V	Rated operational current in AC-3 440 V up to	UL General Purpose (Continuous Current)	Product Reference	Weight
kW	kW	kW	kW	kW	kW	kW	hp	A	Amp Rating		kg
2.2	4	4	4	5.5	5.5	-	5	9	15	TPRPM009	0.255
9	18.5	18.5	18.5	18.5	18.5	-	20	38	45	TPRPM038	0.255
22	37	37	37	37	37	-	40	80	50	TPRPM080	0.425

TeSys island Power Interface Modules

Specifications

Power Interface Module Product References		TPRPM009	TPRPM038	TPRPM080	
Standards - Certification					
Standards		IEC 60947-1, EN 60947-1, UL 60947-4-1, CSA C22.2 No 60947-4-1			
Product certification		UL, CSA, CCC, EAC			
Function specifications					
Functionalities		Upstream voltage presence detection, electronic thermal overload protection, current monitoring, control of third party power devices when associated with a TPRDG I/O			
Thermal motor protection adjustment range	A	0.18...9	0.76...38	4...80	
Protection reset modes		Remote or automatic			
Metering		<ul style="list-style-type: none"> • Time device is on • Number of events detected • Number of switching cycles • Number of device power cycles • Average current Iavg • Max current Imax • Active and reactive power with voltage module • Active and reactive energy with voltage module • True power factor with voltage module 			
Local signaling		<ul style="list-style-type: none"> • Device status, 1 green/red LED • Load status, 1 green/red LED 			
Motor protection					
Thermal protection adjustment range	A	0.18...9	0.76...38	4...80	
Thermal overload trip class		5...30			
Reset modes		Remote or automatic			
Environment					
Ambient air temperature for storage	°C (°F)	-25...70 (-13...158)			
Ambient air temperature for operation	°C (°F)	-10...50 (14-122). Up to 60 (140) with derating			
Ambient air humidity for operation	%	5...95			
Operating altitude	m (ft)	0...2000 (0...6562) without derating			
IP degree of protection		IP20			
Pollution degree		2			
Protective treatment		TC			
Fire resistance	°C (°F)	960 (1760) conforming to UL 94 850 (1562) conforming to IEC 60695-2-1 650 (1202) conforming to IEC 60695-2-12			
Vibration resistance	mm	1.5 peak to peak (3...13 Hz) conforming to IEC 60068-2-6 1 gn (13...200 Hz) conforming to IEC 60068-2-6			
Authorised mounting modes		Horizontal and vertical, on 35 mm symmetrical DIN rail			
Shock resistance		15 gn (duration = 11 ms) conforming to IEC 60068-2-27			
Electromagnetic compatibility		<ul style="list-style-type: none"> • Electrostatic discharge at 8 kV air, 6 kV contact conforming to EN/IEC 61000-4-2 level 3 • Radiated RF fields at 10 V/m conforming to EN/IEC 61000-4-3 level 3 • Fast transient immunity test at 4 kV conforming to EN/IEC 61000-4-4 level 4 • Surges, differential mode at 2 kV conforming to EN/IEC 61000-4-5 level 3 • Surges, common mode at 4 kV conforming to EN/IEC 61000-4-5 level 4 • Conducted RF disturbances at 20 V conforming to EN/IEC 61000-4-6 			
Power pole specifications					
Rated operational voltage [Ue] 47...63 Hz	V	≤ 690			
Rated insulation voltage [Ui]	V	600 - CSA certification 600 - UL certification 690 - conforming to IEC 60947-4-1			
Rated impulse withstand voltage [Uimp]	kV	6 conforming to IEC 60947			
Overvoltage category		III			
Rated operational current [Ie] (≤ 50 °C) at ≤ 440 V AC-3	A	9	38	80	
(≤ 50 °C) at ≤ 440 V AC-1	A	15	40	80	
Free air thermal current [Ith] ≤ 50 °C	A	15	40	80	
Control circuit					
Operating voltage supplied by bus coupler [Uc] DC	V	24			
Current consumption on control circuit	mA	60			
Power connection					
Screw-clamp terminal capacity	1 rigid cable	mm ² /AWG	1-4 / AWG 16...AWG 12	1.5-4 / AWG 16...AWG 12	1-35 / AWG 16...AWG 2 (Everlink terminal)
	2 rigid cables	mm ² /AWG	1-4 / AWG 16...AWG 12	1.5-4 / AWG 16...AWG 12	1-25 / AWG 16...AWG 4 (Everlink terminal)
	1 flexible cable	mm ² /AWG	1.5-4 / AWG 16...AWG 12	2.5-10 / AWG 14...AWG 8	1-35 / AWG 16...AWG 2 (Everlink terminal)
	2 flexible cables	mm ² /AWG	1.5-4 / AWG 16...AWG 12	2.5-10 / AWG 14...AWG 8	1-25 / AWG 16...AWG 4 (Everlink terminal)
	1 flexible cable with cable end	mm ² /AWG	1-4 / AWG 16...AWG 12	1.5-10 / AWG 16...AWG 8	1-35 / AWG 16...AWG 2 (Everlink terminal)
	2 flexible cables with cable end	mm ² /AWG	1-2.5 / AWG 16...AWG 14	1.5-6 / AWG 16...AWG 10	1-25 / AWG 16...AWG 4 (Everlink terminal)
Tightening torque	With flat Ø 6 mm screwdriver	N.m/lb-in	1.7 / 15	2.5 / 22	5 / 44 (1-25 mm ² / AWG 16-4 cable - hexa 4 mm)
	With Philips screwdriver	N.m/lb-in	1.7 / 15 (Philips n°2)	2.5 / 22 (Philips n°3)	8 / 70 (25-35 mm ² / AWG 2 cable - hexa 4 mm)

TeSys island Power Interface Modules

Dimensions

Size 1 (TPRPM009) and Size 2 (TPRPM038)
Power Interface Modules

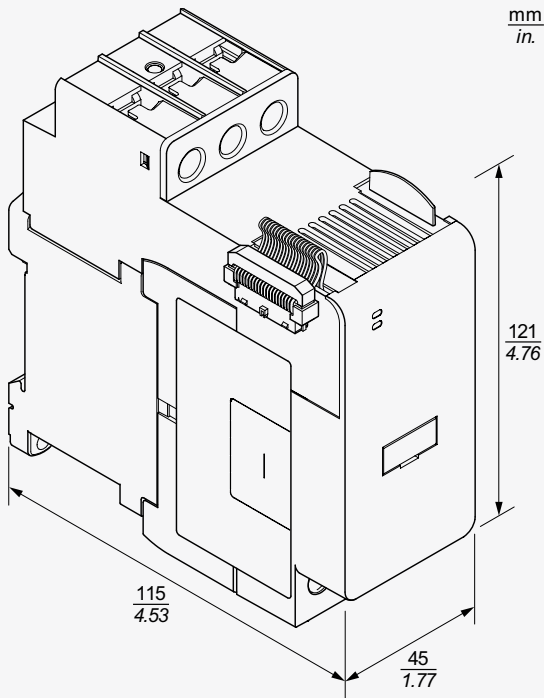

Size 3 (TPRPM080)
Power Interface Module

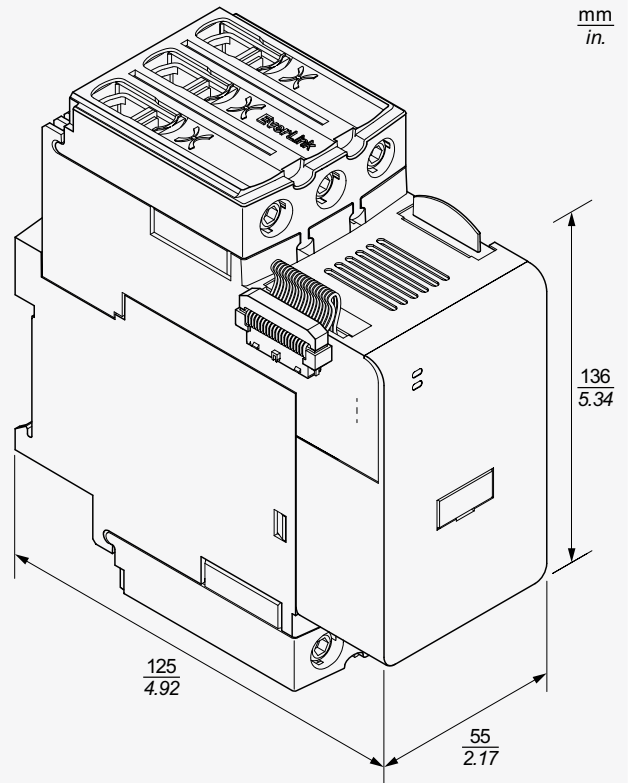

Wiring diagrams



TeSys island Standard Starters

Introduction

Standard Starters (ST), for load control



Standard starters provide load control, electrical and thermal protection functions, and digital asset management capabilities.

Main functions

- Provide three/single phase On/Off power control for loads
- Advanced protection & alarming
- Electrical data measurement related to the load
- Energy monitoring when a voltage interface module (VIM) is installed on the island
- Functional testing and simulation
- Event logging and counters.

The standard starters are connected

- Upstream to a circuit breaker
- Downstream to the load to control.

The starter communicates with the bus coupler, sending operational data and receiving commands.

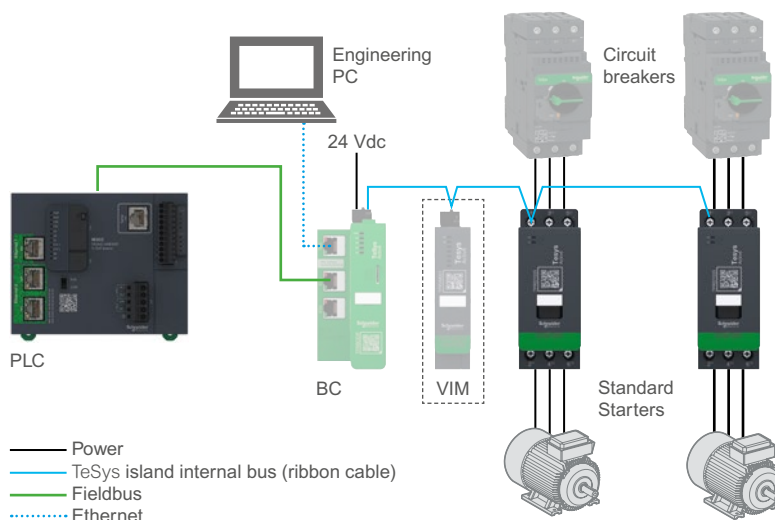
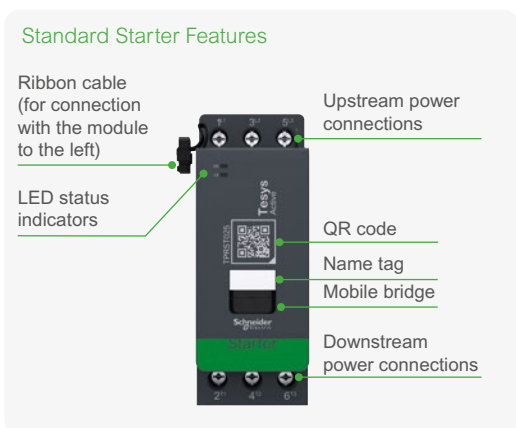

Reversing motor starter
 Obtained by combining 2 standard starters and a cabling kit (See page 36)

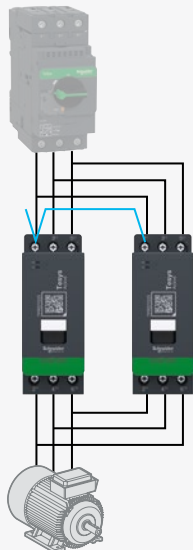

3-Pole Standard Starters														UL General Purpose (Continuous Current Amp Rating)	Rated operational current in AC-3 440 V up to	Product Ref.	Weight	
Standard power ratings of 3-phase motors 50-60 Hz in category AC-3 ($\theta \leq 60^\circ\text{C}$)																		
IEC							UL							A	A		kg	
220V	380V	415V	440V	500V	660V	1000V	120V	240V	208V	240V	460V	600V	1ph					1ph
kW	kW	kW	kW	kW	kW	kW	hp	hp	hp	hp	hp	hp	hp	hp	hp	hp	hp	hp
2.2	4	4	4	5.5	5.5	-	.33	1	2	2	5	7.5	15	9	TPRST009	0.656		
5.5	11	11	11	15	15	-	2	3	7.5	7.5	15	20	30	25	TPRST025	0.718		
9	18.5	18.5	18.5	18.5	18.5	-	2	5	10	10	20	25	40	38	TPRST038	0.718		
18.5	30	37	37	37	37	-	5	10	20	20	40	50	80	65	TPRST065	1.248		
18.5	37	37	37	37	37	-	5	10	20	20	40	50	80	66	TPRST080	1.248		

TeSys island Standard Starters Specifications

Standard Starter Product References		TPRST009	TPRST025	TPRST038	TPRST065	TPRST080
Standards - Certification						
Standards		EN/IEC 60947-1, EN/IEC 60947-4-1, UL 60947-4-1, CSA C22.2 No 60947-4-1				
Product certification		UL, CSA, CCC, EAC				
Function specifications						
Functionalities		<ul style="list-style-type: none"> Upstream voltage presence detection Current monitoring Electronic thermal overload protection 				
Protection reset modes		Remote or automatic				
Metering		<ul style="list-style-type: none"> Time device is on Number of events detected Number of switching cycles Number of device power cycles Average current Iavg Max current Imax Active and reactive power with voltage module Active and reactive energy with voltage module True power factor with voltage module 				
Local signaling		<ul style="list-style-type: none"> Device status, 1 green/red LED Load status, 1 green/red LED 				
Motor protection						
Protection type		<ul style="list-style-type: none"> Thermal overload protection Motor overheat Overcurrent Undercurrent Jam Long start Stall Rapid cycle lockout Rapid restart lockout Phase configuration Phase loss Phase reversal Phase unbalance Ground current 				
Thermal protection adjustment range	A	0.18...9	0.5...25	0.76...38	3.35...65	4...80
Thermal overload trip class		5...30				
Reset modes		Remote or automatic				
Environment						
Ambient air temperature for storage	°C (°F)	-25...70 (-13...158)				
Ambient air temperature for operation	°C (°F)	-10...50 (14-122). Up to 60 (140) with derating				
Ambient air humidity for operation	%	5...95				
Operating altitude	m (ft)	0...2000 (0...6562) without derating				
IP degree of protection		IP20				
Pollution degree		2				
Protective treatment		TC				
Fire resistance	°C (°F)	960 (1760) conforming to UL 94 850 (1562) conforming to IEC 60695-2-1 650 (1202) conforming to IEC 60695-2-12				
Vibration resistance	mm	1.5 peak to peak (3...13 Hz) conforming to IEC 60068-2-6 1 gn (13...200 Hz) conforming to IEC 60068-2-6				
Authorised mounting modes		Horizontal and vertical, on 35 mm symmetrical DIN rail				
Shock resistance		15 gn (duration = 11 ms) conforming to IEC 60068-2-27				
Electromagnetic compatibility		<ul style="list-style-type: none"> Electrostatic discharge at 8 kV air, 6 kV contact conforming to EN/IEC 61000-4-2 level 3 Radiated RF fields at 10 V/m conforming to EN/IEC 61000-4-3 level 3 Fast transient immunity test at 4 kV conforming to EN/IEC 61000-4-4 level 4 Surges, differential mode at 2 kV conforming to EN/IEC 61000-4-5 level 3 Surges, common mode at 4 kV conforming to EN/IEC 61000-4-5 level 4 Conducted RF disturbances at 20 V conforming to EN/IEC 61000-4-6 				

A

B

C

TeSys island Standard Starters

Specifications

Standard Starters Product References (cont.)		TPRST009	TPRST025	TPRST038	TPRST065	TPRST080	
Power pole specifications							
Rated Operational Voltage	47...63 Hz	V	≤ 690	≤ 480 for OVC III, ≤ 690 for OVC II	≤ 690	≤ 690	
Rated insulation voltage [Ui]		V	600 - CSA certification				
		V	600 - UL certification				
		V	690 - conforming to IEC 60947-4-1				
Nominal voltage of the supply system per Table H.1 of IEC 60947-1		V	600, 400/690 or lower	277, 277/480, 240/415 or lower ⁽¹⁾	600, 400/690 or lower		
Rated impulse withstand voltage [Uimp]		kV	6 conforming to IEC 60947				
Overvoltage category			III	III for Ue ≤ 480V, II for Ue ≤ 690 V	III	III	
Rated operational current [Ie]	(≤ 50 °C) at ≤ 440 V AC-3	A	9	25	38	65	66
	(≤ 50 °C) at ≤ 440 V AC-1	A	15	30	40	80	80
Free air thermal current [Ith]	≤ 50 °C	A	15	30	40	80	80
Rated making/breaking capacity at 440 V conforming to IEC 60947 [Irms]		A	250	450	550	1000	1000
Rated short-time withstand current (≤ 40 °C) [Icw]	1 s	A	210	380	430	900	900
	10 s	A	105	240	310	520	520
	1 min	A	61	120	150	260	260
	10 min	A	30	50	60	220	110
Power dissipation per pole	AC-3 - at Ith	W	0.2	1.25	2.9	6.3	6.5
	AC-1 - at Ith	W	0.56	1.8	3.2	9.6	9.6
Average impedance at 50 Hz - at Ith		mΩ	2.5	2	2	1.5	1.5
Mechanical durability		Mcycles	30			6	6
Electrical durability	AC-3 - at Ith, Ue 440 V	Mcycles	2	1.65	1.4	1.4	0.75
	AC-1 - at Ith, Ue 440 V	Mcycles	1.2	2	2	0.5	0.5
Operating time	Closing	ms	< 100			< 80	
	Opening	ms	< 30			< 80	
Maximum operating rate	AC-3		3600 cycles/hour				
Control circuit							
Operating voltage supplied by bus coupler [Uc]	DC	V	24				
Current consumption	Sealed	mA	160			80	80
	Closing	mA	160			500	500
Power max dissipation at Ie AC-3		W	3.5	6.6	11.8	20.8	21.4
Power connection							
Screw-clamp terminal capacity	1 rigid cable	mm ² /AWG	1- 4 / AWG 16...AWG 12	1.5- 10 / AWG 16...AWG 8	1-35 / AWG 16... AWG 2 (Everlink terminal)		
	2 rigid cables	mm ² /AWG	1- 4 / AWG 16...AWG 12	2.5- 10 / AWG 14...AWG 8	1-25 / AWG 16... AWG 4 (Everlink terminal)		
	1 flexible cable	mm ² /AWG	1.5- 4 / AWG 16...AWG 12	2.5- 10 / AWG 14...AWG 8	1-35 / AWG 16... AWG 2 (Everlink terminal)		
	2 flexible cables	mm ² /AWG	1.5- 4 / AWG 16...AWG 12	2.5- 10 / AWG 14...AWG 8	1-25 / AWG 16... AWG 4 (Everlink terminal)		
	1 flexible cable with cable end	mm ² /AWG	1- 4 / AWG 16...AWG 12	1- 6 / AWG 16...AWG 10	1-35 / AWG 16... AWG 2 (Everlink terminal)		
	2 flexible cables with cable end	mm ² /AWG	1- 2.5 / AWG 16...AWG 14	1.5- 6 / AWG 16...AWG 10	1-25 / AWG 16... AWG 4 (Everlink terminal)		
Tightening torque	With flat Ø 6 mm screwdriver	N.m/lb-in	1.7 / 15	2.5 / 22	5 / 44 (1-25 mm ² / AWG 16-4 cable- hexa 4 mm)		
	With Philips screwdriver	N.m/lb-in	1.7 / 15 (Philips n°2)	2.5 / 22 (Philips n°3)	8 / 70 (35 mm ² / AWG 2 cable -hexa 4 mm)		

(1) Maximum 300 V rated operational voltage to earth (ground) per table H.1 of IEC 60947-1 (including 400/230 and 480/277 power systems) for TPRST025, TPRST038 unless used with appropriate Surge Protective Device limiting the system to OVC II.

For 500V/600V/690V applications and rated motor current above 3.35 A, TPRST065 device can be used.

TeSys island Standard Starters

Dimensions

Size 1 Starters: TPRST009 and TPRSS009

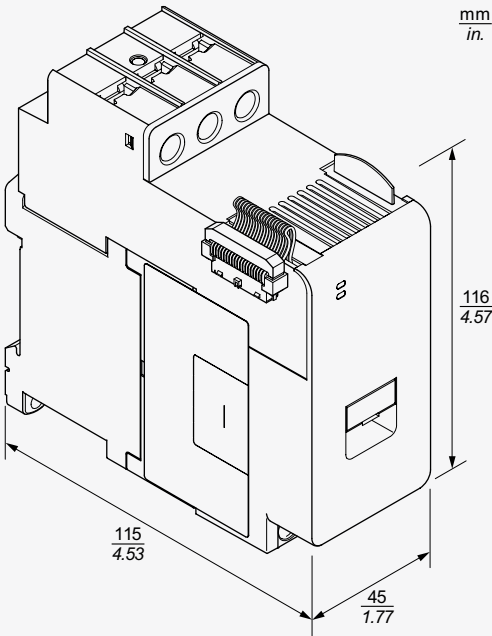

Size 2 Starters: TPRST025, TPRST038, TPRSS025 and TPRSS038

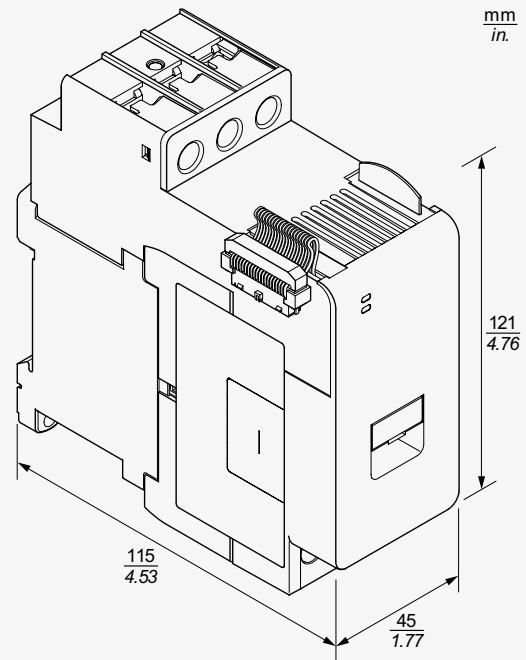

Size 3 Starters: TPRST065, TPRST080, TPRSS065 and TPRSS080

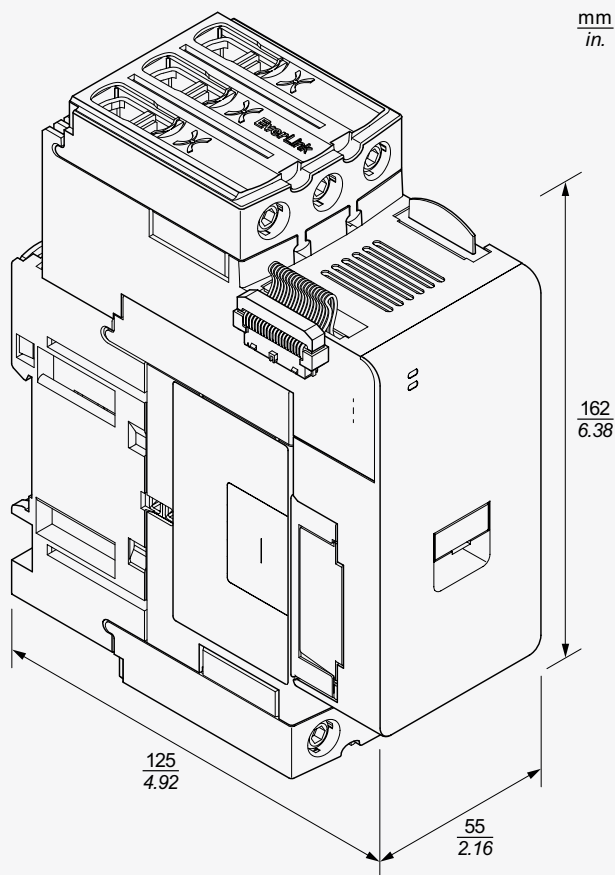

Wiring diagrams



TeSys island SIL Starters Introduction

SIL Starter (SS)



TPRSS009 TPRSS025
TPRSS038 TPRSS065
TPRSS080

SIL starters provide similar functions as standard starters but are associated with a SIL interface module (SIM).

Main functions

- Provide Stop Category 0 and Stop Category 1 according to EN/IEC 60204-1
- Provide three-phase/single-phase On/Off power control for loads
- Advanced protection & alarming
- Electrical data measurement related to the load
- Energy monitoring when a voltage interface module (VIM) is installed on the island
- Functional testing and simulation
- Event logging and counters.

Multiple SIL starters might be needed for a single TeSys™ avatar function. Avatars using SIL starters always include a SIL interface module.

The SIL starters are connected

- Upstream to a circuit breaker
- Downstream to the load to control
- To SIM module of the same group via the TeSys island internal bus (ribbon cable).

The SIL starter communicates with the bus coupler, sending operational data and receiving commands.

SIL Starter Features

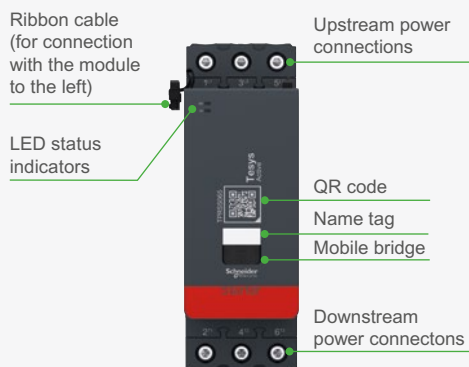

Reversing SIL motor starter

is obtained by combining 2 SIL starters and a cabling kit (See page 36)

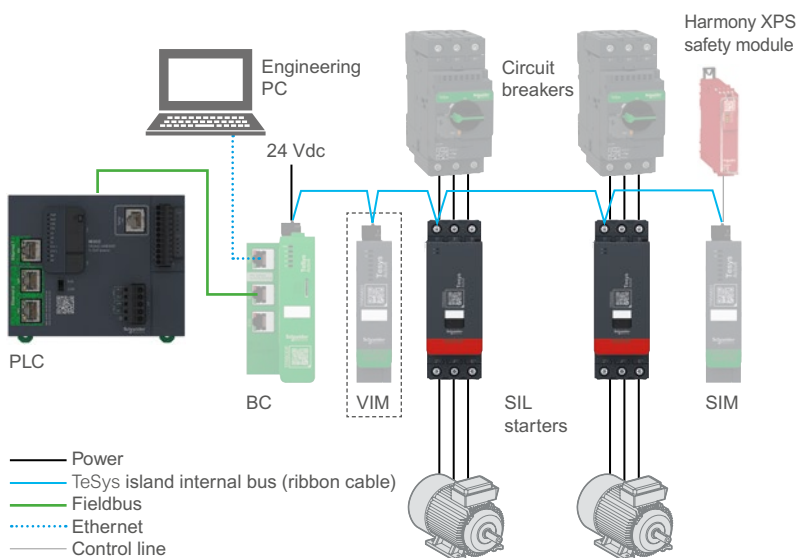
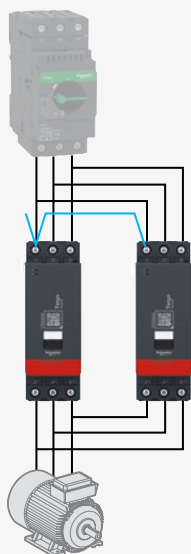

3-Pole SIL Starters

Standard power ratings of 3-phase motors
50-60 Hz in category AC-3
(θ ≤ 60°C)

IEC							UL							UL General Purpose (Continuous Current Amp Rating)	Rated operational current in AC-3 440 V up to	Product Ref.	Weight
220V	380V	415V	440V	500V	660V	1000V	120V	240V	208V	240V	460V	600V					
230V	400V			690V			1 ph	1 ph	3 ph	3 ph	480V	3 ph					
kW	kW	kW	kW	kW	kW	kW	hp	hp	hp	hp	hp	hp	A	A		kg	
2.2	4	4	4	5.5	5.5	-	.33	1	2	2	5	7.5	15	9	TPRST009	0.656	
5.5	11	11	11	15	15	-	2	3	7.5	7.5	15	20	30	25	TPRST025	0.718	
9	18.5	18.5	18.5	18.5	18.5	-	2	5	10	10	20	25	40	38	TPRST038	0.718	
18.5	30	37	37	37	37	-	5	10	20	20	40	50	80	65	TPRST065	1.248	
18.5	37	37	37	37	37	-	5	10	20	20	40	50	80	66	TPRST080	1.248	

TeSys island SIL Starters Specifications

SIL Starter Product References		TPRSS009	TPRSS025	TPRSS038	TPRSS065	TPRSS080
Standards - Certification						
Standards		EN/IEC 60947-1, EN/IEC 60947-4, UL 60947-4-1, CSA C22.2 No 60947-4-1				
Product certification		UL, CSA, CCC, EAC				
Function specifications						
Functionalities		<ul style="list-style-type: none"> Upstream voltage presence detection Current monitoring Electronic thermal overload protection 				
Functional safety ⁽¹⁾		Stop Category 0 and Stop Category 1 conforming to EN/IEC 60204-1 when associated with a TPRSM module				
Safety integrity level ⁽²⁾		<ul style="list-style-type: none"> SIL 2 conforming to IEC 61508 in single channel system architecture SILCL 2 conforming to IEC 62061 in single channel system architecture PL = d category 2 conforming to ISO 13849-1 in single channel system architecture 				
Metering		<ul style="list-style-type: none"> Time device is on Number of events detected Number of switching cycles Number of device power cycles Average current Iavg Max current Imax Active and reactive power with voltage module Active and reactive energy with voltage module True power factor with voltage module 				
Local signaling		<ul style="list-style-type: none"> Device status, 1 green/red LED Load status, 1 green/red LED 				
Motor protection						
Protection type		<ul style="list-style-type: none"> Thermal overload protection Motor overheat Overcurrent Undercurrent Jam Long start Stall Rapid cycle lockout Rapid restart lockout Phase configuration Phase loss Phase reversal Phase unbalance Ground current 				
Thermal protection adjustment range	A	0.18...9	0.5...25	0.76...38	3.35...65	4...80
Thermal overload class		5...30				
Reset modes		Remote or automatic				
Environment						
Ambient air temperature for storage	°C (°F)	-25...70 (-13...158)				
Ambient air temperature for operation	°C (°F)	-10...60 (14...140)				
Ambient air humidity for operation	%	5...95				
Operating altitude	m (ft)	0...2000 (0...6562) without derating				
IP degree of protection		IP20				
Pollution degree		2				
Protective treatment		TC				
Fire resistance	°C (°F)	960 (1760) conforming to UL 94 850 (1562) conforming to IEC 60695-2-1 650 (1202) conforming to IEC 60695-2-12				
Vibration resistance	mm	1.5 peak to peak (3...13 Hz) conforming to IEC 60068-2-6 1 gn (13...200 Hz) conforming to IEC 60068-2-6				
Authorised mounting modes		Horizontal and vertical, on 35 mm symmetrical DIN rail				
Shock resistance		15 gn (duration = 11 ms) conforming to IEC 60068-2-27				
Electromagnetic compatibility		<ul style="list-style-type: none"> Electrostatic discharge at 8 kV air, 6 kV contact conforming to EN/IEC 61000-4-2 level 3 Radiated RF fields at 10 V/m conforming to EN/IEC 61000-4-3 level 3 Fast transient immunity test at 4 kV conforming to EN/IEC 61000-4-4 level 4 Surges, differential mode at 2 kV conforming to EN/IEC 61000-4-5 level 3 Surges, common mode at 4 kV conforming to EN/IEC 61000-4-5 level 4 Conducted RF disturbances at 20 V conforming to EN/IEC 61000-4-6 				

(1) Functional safety as defined in IEC 61508

(2) Safety Integrity Level according to standard IEC 61508

TeSys island SIL Starters

Specifications

SIL Starter Product References (cont.)			TPRSS009	TPRSS025	TPRSS038	TPRSS065	TPRSS080
Power pole specifications							
Rated Operational Voltage [Ue]	47...63 Hz	V	≤ 690	≤ 480 for OVC III, ≤ 690 for OVC II		≤ 690	≤ 690
Rated insulation voltage [Ui]		V	600 - CSA certification 600 - UL certification 690 - conforming to IEC 60947-4-1				
Nominal voltage of the supply system per Table H.1 of IEC 60947-1		V	600, 400/690 or lower	277, 277/480, 240/415 or lower ⁽¹⁾		600, 400/690 or lower	
Rated impulse withstand voltage [Uimp]		kV	6 conforming to IEC 60947				
Overvoltage category			III	III for Ue ≤ 480V, II for Ue ≤ 690 V		III	III
Rated operational current [Ie]	(≤ 50 °C) at ≤ 440 V AC-3	A	9	25	38	65	66
	(≤ 50 °C) at ≤ 440 V AC-1	A	15	30	40	80	80
Free air thermal current [Ith]	≤ 50 °C	A	15	30	40	80	80
Rated making capacity at 440 V conforming to IEC 60947 [Irms]		A	250	450	550	1000	1000
Rated breaking capacity at 440 V conforming to IEC 60947		A	250	450	550	1000	1000
Rated short-time withstand current (≤ 40 °C) [Icw]	1 s	A	210	380	430	900	900
	10 s	A	105	240	310	520	520
	1 min	A	61	120	150	260	260
	10 min	A	30	50	60	220	110
Power dissipation per pole	AC-3 - at Ith	W	0.2	1.25	2.9	6.3	6.5
	AC-1 - at Ith	W	0.56	1.8	3.2	9.6	9.6
Average impedance	at 50 Hz - at Ith	mΩ	2.5	2	2	1.5	1.5
Mechanical durability		Mcycles	30			6	6
Electrical durability	AC-3 - at Ith, Ue 440 V	Mcycles	2	1.65	1.4	1.4	0.75
	AC-1 - at Ith, Ue 440 V	Mcycles	1.2	2	2	0.5	0.5
Operating time	Closing	ms	65...88			55 ... 65	55 ... 65
	Opening	ms	20...30			20 ... 80	20 ... 80
Maximum operating rate	AC-3		3600 cycles/hour				

Control circuit

[Uc] operating voltage supplied by bus coupler	DC	V	24				
Current consumption	Sealed	mA	160			80	80
	Closing	mA	160			500	500
Power max dissipation at Ie AC-3		W	3.5	6.6	11.8	20.8	21.4

Power connection

Screw-clamp terminal capacity	1 rigid cable	mm ² /AWG	1- 4 / AWG 16...AWG 12	1.5- 10 / AWG 16...AWG 8	1-35 / AWG 16... AWG 2 (Everlink terminal)	
	2 rigid cables	mm ² /AWG	1- 4 / AWG 16...AWG 12	2.5- 10 / AWG 14...AWG 8	1-25 / AWG 16... AWG 4 (Everlink terminal)	
	1 flexible cable	mm ² /AWG	1.5- 4 / AWG 16...AWG 12	2.5- 10 / AWG 14...AWG 8	1-35 / AWG 16... AWG 2 (Everlink terminal)	
	2 flexible cables	mm ² /AWG	1.5- 4 / AWG 16...AWG 12	2.5- 10 / AWG 14...AWG 8	1-25 / AWG 16... AWG 4 (Everlink terminal)	
	1 flexible cable with cable end	mm ² /AWG	1- 4 / AWG 16...AWG 12	1- 6 / AWG 16...AWG 10	1-35 / AWG 16... AWG 2 (Everlink terminal)	
	2 flexible cables with cable end	mm ² /AWG	1- 2.5 / AWG 16...AWG 14	1.5- 6 / AWG 16...AWG 10	1-25 / AWG 16... AWG 4 (Everlink terminal)	
Tightening torque	With flat Ø 6 mm screwdriver	N.m/lb-in	1.7 / 15	2.5 / 22	5 / 44 (1-25 mm ² / AWG 16-4 cable- hexa 4 mm)	
	With Philips screwdriver	N.m/lb-in	1.7 / 15 (Philips n°2)	2.5 / 22 (Philips n°3)	8 / 70 (35 mm ² / AWG 2 cable -hexa 4 mm)	

(1) Maximum 300 V rated operational voltage to earth (ground) per table H.1 of IEC 60947-1 (including 400/230 and 480/277 power systems) for TPRSS025, TPRSS038 unless used with appropriate Surge Protective Device limiting the system to OVC II.
For 500V/600V/690V applications and rated motor current above 3.35 A, TPRSS065 device can be used.

TeSys island SIL Starters Dimensions

Size 1 Starters: TPRST009 and TPRSS009

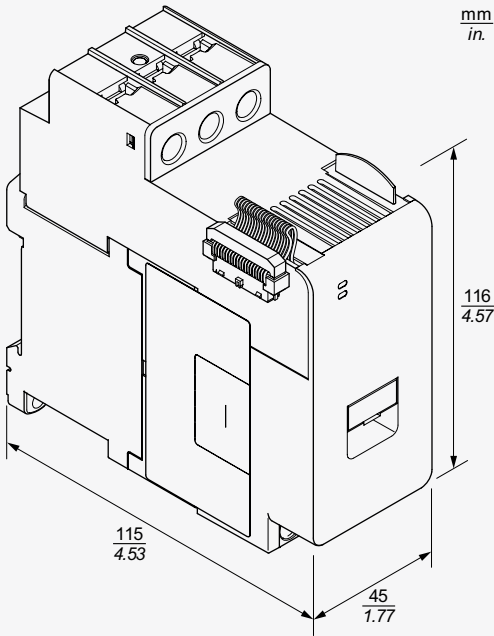

Size 2 Starters: TPRST025, TPRST038, TPRSS025 and TPRSS038

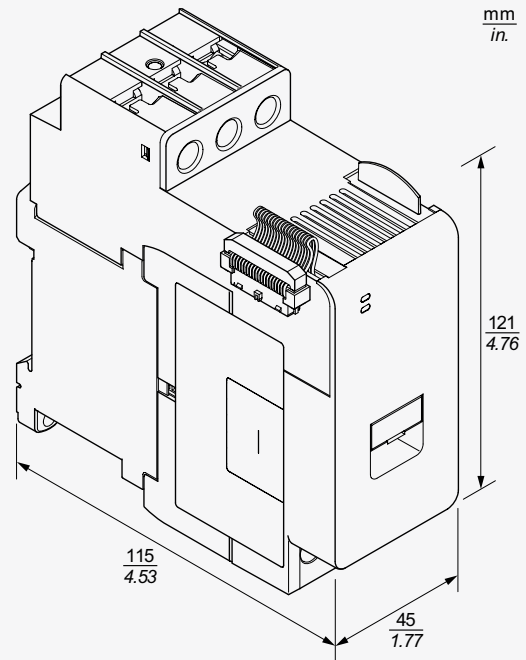

Size 3 Starters: TPRST065, TPRST080, TPRSS065 and TPRSS080

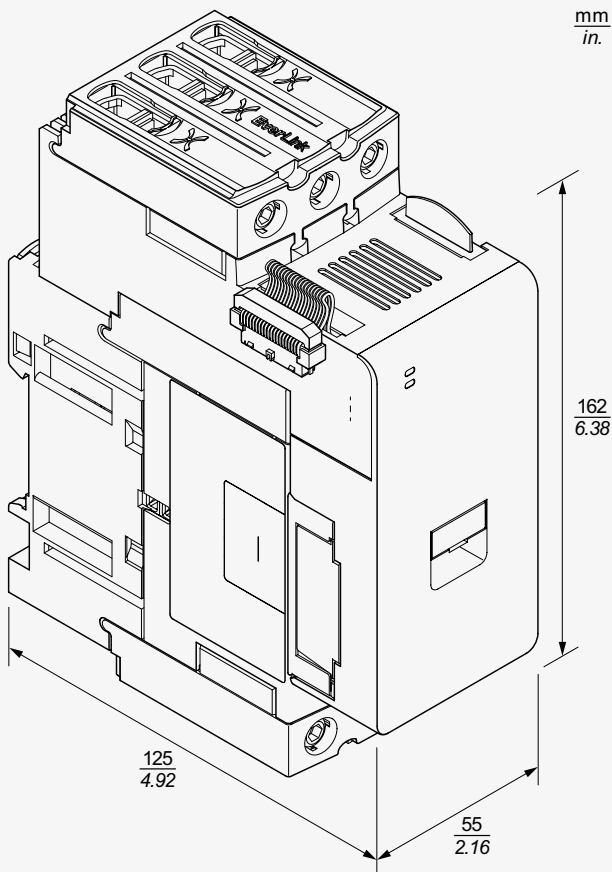

Wiring diagrams



A

B

C

TeSys island SIL Interface Module

Introduction

SIL Interface Module, to provide interface with SIL Starters



TPRSM001

A SIL interface module (SIM), associated with one or several SIL starters, allows the design of Stop functions in compliance with EN/IEC 60204-1:

- Stop Category 0: immediate machine power disconnection
- Stop Category 1: electrical power maintained on the machine actuators until the stop process fully ends (absence of motion).

Main functions

- Interface with a Harmony XPS safety module
- Command the stop function of its SIL group of SIL starters.

Several SIL groups of SIL starters can be set up on the island. Each is delimited by one SIM on the far side of the SIL starters.

The SIM is connected

- Upstream to a Harmony XPS safety module
- To a SIL starter of the same SIL group via the TeSys island internal bus (ribbon cable).

The SIM communicates with the bus coupler, sending operational data.

The Stop function is achieved by pure electromechanical means without any digital communication or bus coupler involvement.

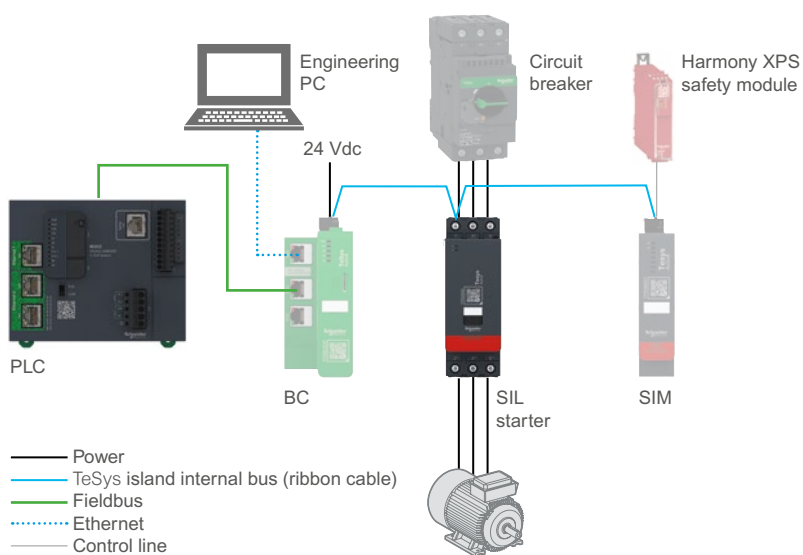
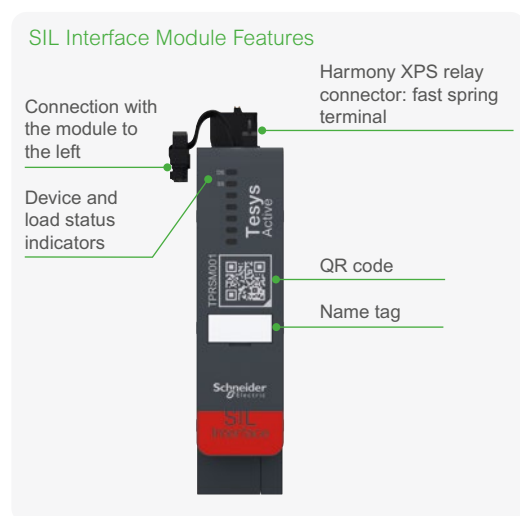

SIL interface module - commercial information

Designation	Voltage (Vdc)	Product Reference	Weight (kg)
TeSys island SIL interface module (SIM)	24	TPRSM001	0.159

TeSys island SIL Interface Module Specifications

SIL Interface Module Product Reference	TPRSM001
---	-----------------

Standards - Certification

Standards	IEC 60947-5-1, UL 60947-5-1, CSA C22.2 No 60947-5-1
Product certification	UL, CSA, EAC

Function specifications

Functionalities	Stop Category 0 and Stop Category 1 conforming to EN/IEC 60204-1 when associated with a TPRSS module
Product compatibility	<ul style="list-style-type: none"> • TPRBC bus coupler • TPRSSxx SIL motor starter
Local signaling	<ul style="list-style-type: none"> • Device status, 1 green/red LED • SIL Stop status, 1 green/red LED

Environment

Ambient air temperature for storage	°C (°F)	-25...70 (-13...158)
Ambient air temperature for operation	°C (°F)	-10...60 (14...140)
Ambient air humidity for operation	%	5...95
Operating altitude	m (ft)	0...2000 (0...6562) without derating
IP degree of protection		IP20
Pollution degree		2
Protective treatment		TC
Fire resistance	°C (°F)	960 (1760) conforming to UL 94
Vibration resistance	mm	1.5 peak to peak (3...13 Hz) conforming to IEC 60068-2-6 1 gn (13...200 Hz) conforming to IEC 60068-2-6
Authorised mounting modes		Horizontal and vertical, on 35 mm symmetrical DIN rail
Shock resistance		15 gn (duration = 11 ms) conforming to IEC 60068-2-27
Electromagnetic compatibility		<ul style="list-style-type: none"> • Electrostatic discharge at 8 kV air, 6 kV contact conforming to EN/IEC 61000-4-2 • Radiated RF fields level 3 at 10 V/m conforming to EN/IEC 61000-4-3 • Fast transient immunity test level 3 at 2 kV conforming to EN/IEC 61000-4-4 • Surge immunity test, level 3 (2 kV) conforming to EN/IEC 61000-4-5 level

Electrical specifications

Rated supply voltage [Us]	Vdc	24
Supply current	mA	10
Max power dissipation	W	0.7
Rated impulse withstand voltage [Uimp]	kV	0.5 conforming to IEC 61010-1
Input type		Isolated switching input for emergency stop
Input protection		Internal, electronic
Input voltage range	'0' state	Vdc
	'1' state	Vdc
		0...5
		15...28.8
Output type		Relay, instantaneous opening, 1 NO circuit(s), potential free
Output protection		External fuse, 8 A gG for relay output
Relay output thermal current	A	8

Connector

Removable spring terminal block	1 rigid cable	mm ² /AWG	0.2... 2.5 / AWG 24... AWG 14
	1 flexible cable	mm ² /AWG	0.2... 2.5 / AWG 24... AWG 14
	1 flexible cable with cable end	mm ² /AWG	0.2... 2.5 / AWG 22... AWG 14

TeSys island SIL Interface Module

Dimensions

SIL Interface Module: TPRSM001

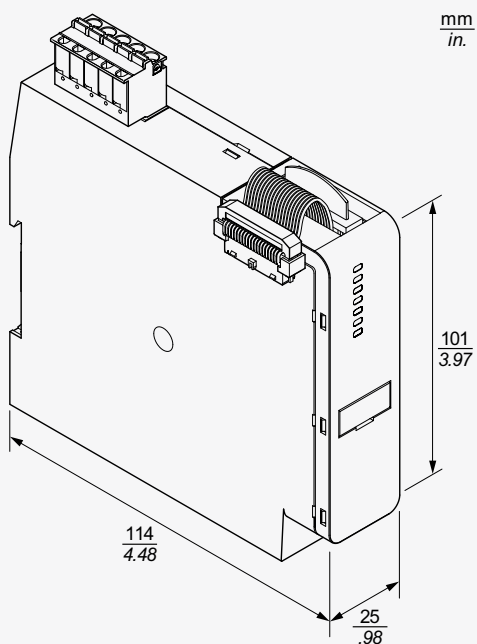

Wiring diagrams

SIM Terminal Block

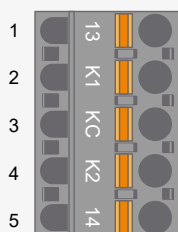

SIM Terminal Block Pinout

Pin Number	Terminal Identification	Signal
1	13	MIRROR IN
2	K1	SIL IN 1
3	KC	SIL COMMON
4	K2	SIL IN 2
5	14	MIRROR OUT

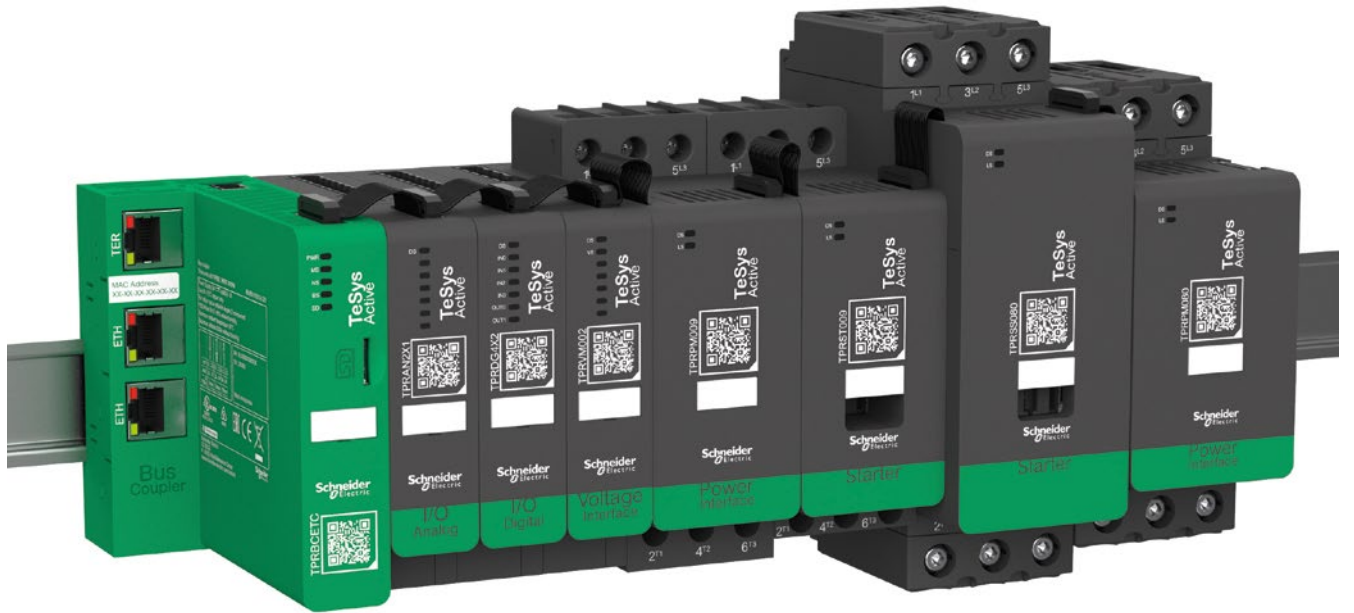

A

B

C

TeSys island Digital I/O module

Introduction

Digital I/O module (DG), monitors and delivers binary status



TPRDG4X2

Digital I/O modules are typically used to get data from sensors and to control devices.

Main functions

- Monitor binary sensors and switches via four 24 Vdc sink/source inputs. No isolation between inputs (share a common ground)
- Control devices like relays, signaling lights, or controller binary inputs via two 0.5 A, 24 Vdc transistor-type outputs. No isolation between outputs (share a common ground)
- Capture statistical operational data of the module:
 - Number of device power cycles
 - Number of device events detected
 - Time module is on
 - Perform I/O channel testing and simulation.

The digital I/O module is connected:

- Upstream to the 24 Vdc source needed to power the downstream actuators
- Input channel: downstream to a binary sensor or switch
- Output channel: downstream to the 24 Vdc input of the actuator

Actuators connected to the digital I/O module must be protected against short-circuits by external means like fuses. The output fuse should be a 0.5 A Type T fuse (215, 218, FLQ or FLSR series from Littelfuse supplier or equivalent), one per output.

The digital I/O module communicates with the bus coupler, sending operational data and receiving commands.

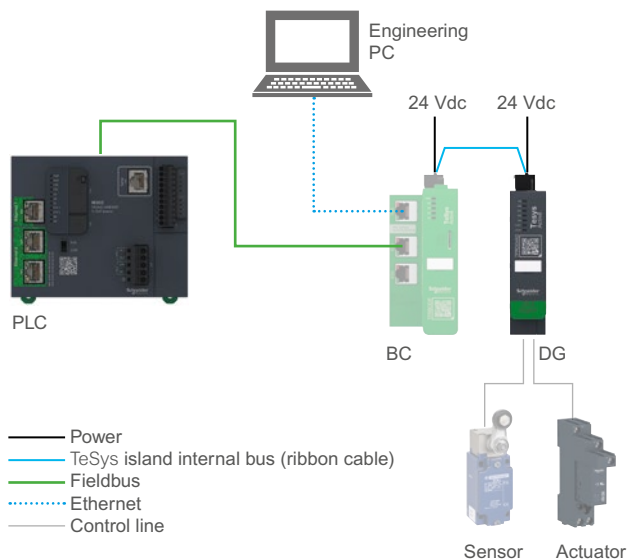

Digital I/O module commercial information				
Designation	Input	Output	Product Reference	Weight (kg)
TeSys island DG - Digital 4I/2O Module	Vdc 24	A / Vdc 0.5 / 24	TPRDG4X2	0.136

TeSys island Digital I/O module

Specifications

Digital I/O Module Product Reference	TPRDG4X2
---	-----------------

Standards - Certification

Standards	IEC 61010-02-201, UL 61010-02-201, CSA C22.2 No 61010-02-201
Product certification	UL, CSA, EAC

Function specifications

Functionalities	<ul style="list-style-type: none"> • Monitoring of 4 digital inputs, configurable positive or negative logic • Control of 2 digital outputs, configurable positive or negative logic
Product compatibility	TPRBC bus coupler, TPRPM power module, TPRST standard starters
Local signaling	<ul style="list-style-type: none"> • DS (device status): 1 LED (green/red) • I0 (input 1 status): 1 LED (green) • I1 (input 2 status): 1 LED (green) • I2 (input 3 status): 1 LED (green) • I3 (input 4 status): 1 LED (green) • Q0 (output 1 status): 1 LED (green) • Q1 (output 2 status): 1 LED (green)

Environment

Ambient air temperature for storage	°C (°F)	-25...70 (-13...158)
Ambient air temperature for operation	°C (°F)	-10...60 (14...140)
Ambient air humidity for operation	%	5...95
Operating altitude	m (ft)	0...2000 (0...6562) without derating
IP degree of protection		IP20
Pollution degree		2
Protective treatment		TC
Fire resistance	°C (°F)	960 (1760) conforming to UL 94
Vibration resistance	mm	1.5 peak to peak (3...13 Hz) conforming to IEC 60068-2-6 1 gn (13...200 Hz) conforming to IEC 60068-2-6
Authorised mounting modes		Horizontal and vertical, on 35 mm symmetrical DIN rail
Shock resistance		15 gn (duration = 11 ms) conforming to IEC 60068-2-27
Electromagnetic compatibility		<ul style="list-style-type: none"> • Electrostatic discharge at 8 kV air, 6 kV contact conforming to EN/IEC 61000-4-2 • Radiated RF fields level 3 at 10 V/m conforming to EN/IEC 61000-4-3 • Fast transient immunity test level 3 at 2 kV conforming to EN/IEC 61000-4-4 • Surge immunity test, level 3 (2 kV) conforming to EN/IEC 61000-4-5 level

Electrical specifications

Rated supply voltage [Us]	Vdc	24	
Current consumption on power supply	mA	160	
Rated impulse withstand voltage [Uimp]	kV	0.5 conforming to IEC 61010-1	
Max power dissipation	W	0.5	
Number of digital inputs / compliance		4 conforming to IEC 61131-2 Type 1	
Digital input voltage, typical (min, max)	Vdc	24 (19.2...28.8)	
Digital input current, under 24 Vdc	mA	7	
Input impedance	Ω	<ul style="list-style-type: none"> ≤ 50 Ohm for current ≥ 1 MOhm for voltage ≥ 1 MOhm for thermocouple ≥ 1 MOhm for temperature probe 	
Digital input logic levels	'0'	Vdc	0...5
	'1'	Vdc	15...28.8
Number of digital output			2 - static outputs
Output logic			Configurable: positive or negative
Digital output voltage, typical (min, max)	Vdc	24 (19.2...28.8)	
Digital output current	A	0.5 with resistive load	
Digital output protection			External fast fuse required - 1 per output: F 0.5 A
Electrical insulation - Digital input to digital output	Vrms	500	
Electrical insulation - Digital input, digital output to rest of circuit (internal Bus...)	Vrms	2500	
Reponse time	ms	5 ms at 24 V for digital input 5 ms at 24 V for digital output	

Connector

Removable spring terminal block	1 rigid cable	mm ² /AWG	0.2...2.5 / AWG 24...AWG 14
	1 flexible cable	mm ² /AWG	0.2...2.5 / AWG 24...AWG 14
	1 flexible cable with cable end	mm ² /AWG	0.2...2.5 / AWG 22...AWG 14

TeSys island Digital I/O module

Dimensions

Digital I/O module: TPRDG4X2

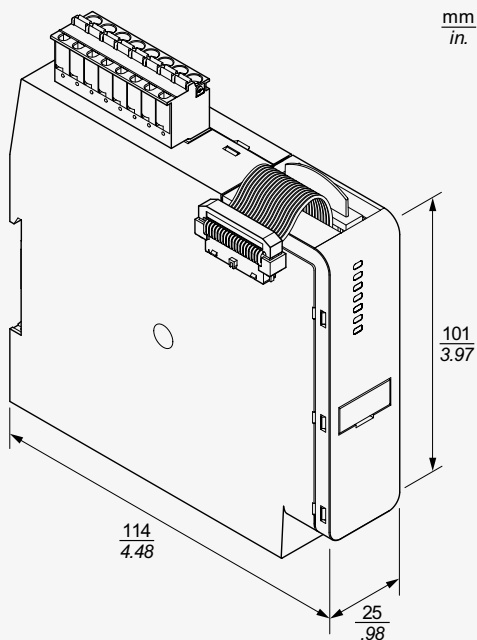

Wiring diagrams

Digital I/O module

Terminals

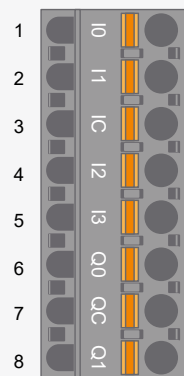

Pin	Terminal Identification	Digital I/O module
1 (Closest to DIN rail)	I0	Input 0
2	I1	Input 1
3	IC	Input Common
4	I2	Input 2
5	I3	Input 3
6	Q0	Output 0
7	QC	Output Common
8 (Closest to front face)	Q1	Output 1

Digital I/O Wiring

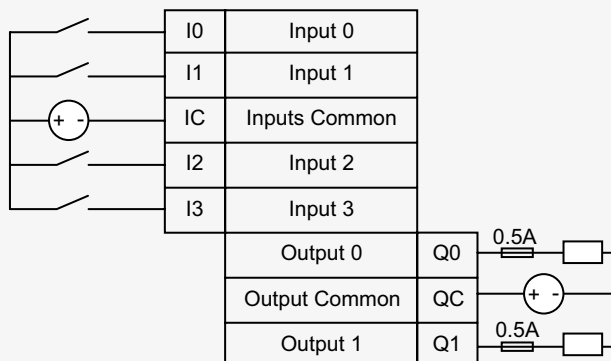

TeSys island Analog I/O module Introduction

Analog I/O module (AN), monitors and delivers analog values

A

B

C



TPRAN2X1

Analog I/O modules are typically used to get data from sensors and to control devices.

Main functions

- Monitor RTD, Thermocouple (NI100, NI1000, PT100, PT1000, PTC binary, thermocouple type B, C, E, J, K, N, R, S, T), Voltage & Current analog readings (0–10V, -10...+10V, 0–20 mA, 4–20 mA) through 2 configurable inputs
- Control voltage & current output via 1 configurable analog output (0–10V, -10...+10V, 0–20 mA, 4–20 mA)
- Capture statistical operational data:
 - Number of device power cycles
 - Number of device events detected
 - Time module is on.

The analog I/O module is connected

- Input channel: downstream to an analog sensor or sensor transmitter
- Output channel: downstream to the control input of a voltage-driven actuator, such as a variable-speed drive

Devices connected to the outputs of the I/O module must be protected against short circuits by external means like fuses.

The analog I/O module communicates with the bus coupler, sending operational data and receiving commands.

Note: No per-channel LEDs are provided.

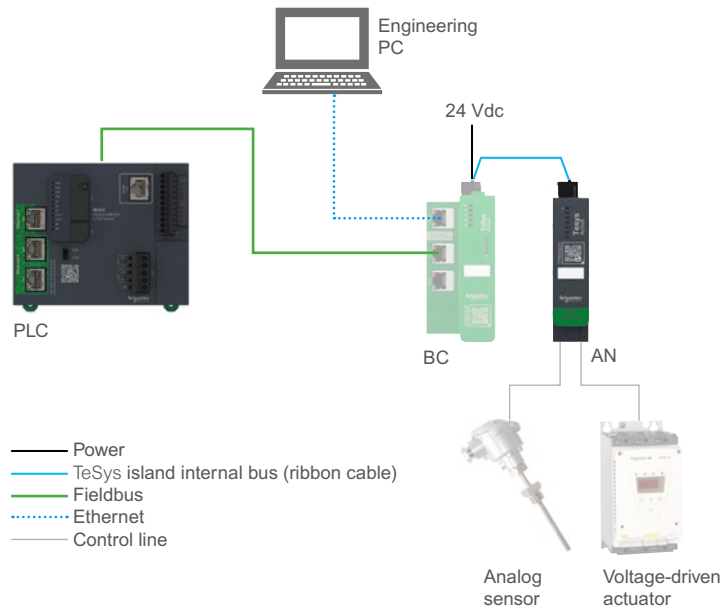

Analog I/O module commercial information						
Designation	Inputs		Output		Product Reference	Weight (kg)
	mA dc	Vdc	mA dc	Vdc		
TeSys island - Analog 2I/1O Module	0-20	-10 to +10	0-20	-10 to +10	TPRAN2X1	0.172
	4-20	0-10	4-20	0-10		
	Thermocouple					

TeSys island Analog I/O module

Specifications

Analog I/O Module Product Reference		TPRAN2X1	
Standards - Certification			
Standards		IEC 61010-02-201, UL 61010-02-201, CSA C22.2 No 61010-02-201	
Product certification		UL, CSA, EAC	
Function specifications			
Functionalities		<ul style="list-style-type: none"> • Voltage, current, or temperature measurement, by 2 configurable analog inputs • Voltage or current source control, by 1 configurable analog output 	
Product compatibility		TPRBC bus couples, TPRST standard starters, TPRSS SIL starters	
Local signaling		Device status, 1 green/red LED	
Environment			
Ambient air temperature for storage	°C (°F)	-25...70 (-13...158)	
Ambient air temperature for operation	°C (°F)	-10...60 (14...140)	
Ambient air humidity for operation	%	5...95	
Operating altitude	m (ft)	0...2000 without derating	
IP degree of protection		IP20	
Pollution degree		2	
Protective treatment		TC	
Fire resistance	°C (°F)	960 (1760) conforming to UL 94	
Vibration resistance	mm	1.5 peak to peak (3...13 Hz) conforming to IEC 60068-2-6 1 gn (13...200 Hz) conforming to IEC 60068-2-6	
Authorised mounting modes		Horizontal and vertical, on 35 mm symmetrical DIN rail	
Shock resistance		15 gn (duration = 11 ms) conforming to IEC 60068-2-27	
Electromagnetic compatibility		<ul style="list-style-type: none"> • Electrostatic discharge, level 3 at 8 kV air, 6 kV contact conforming to EN/IEC 61000-4-2 • Radiated RF fields level 3 at 10 V/m conforming to EN/IEC 61000-4-3 • Fast transient immunity test level 3 at 2 kV conforming to EN/IEC 61000-4-4 • Surge immunity test, level 3 (2 kV) conforming to EN/IEC 61000-4-5 level 	
Electrical specifications			
Current consumption on power supply	mA	160	
Max power dissipation	W	0.5	
Number of analog inputs		2	
Analog Input - current measurement range	mA	4...20 0...20	
Analog Input - voltage measurement range	Vdc	0...10 - 10... +10	
Analog Input - temperature measurement range / sensor	°C (°F)	-60...180 °C with temperature probe Ni 100 -60...180 °C with temperature probe Ni 1000 -200...850 °C with temperature probe Pt 100 -200...600 °C with temperature probe Pt 1000 -200...1000 °C with thermocouple J -200...1300 °C with thermocouple K 0...1760 °C with thermocouple R 0...1760 °C with thermocouple S 0...1820 °C with thermocouple B -200...400 °C with thermocouple T -200...1300 °C with thermocouple N -200...800 °C with thermocouple E 0...2315 °C with thermocouple C	
Analog input measurement accuracy	%	± 0.1 of full scale voltage ± 0.1 of full scale current ± 0.1 of full scale temperature probe ± 0.1 of full scale in positive temperature range thermocouple ± 0.4 of full scale in negative temperature range thermocouple	
Analog input measurement resolution	bits	15 + sign full scale	
Analog input impedance /	Ω	≤ 50 Ohm for current ≥ 1 MOhm for voltage ≥ 1 MOhm for thermocouple ≥ 1 MOhm for temperature probe	
Electrical insulation - Analog channels / rest of circuit (internal Bus...)	Vrms	2500 - Isolated by the use of photocouplers	
Number of analog output		1	
Analog output type /range	Current	mA	4...20 0...20
	Voltage	Vdc	0...10 - 10...+10
Analog output resolution / range	4...20 mA	bits	12, full scale
	0...20 mA	bits	12, full scale
	0...10 V	bits	12, full scale
	-10...+10 V	bits	11 + sign, full scale

TeSys island Analog I/O module Specifications

Analog I/O Module Product Reference (cont.)	TPRAN2X1
--	-----------------

I/O wiring

Recommended cable		Twisted pair, shielded
Max length per IO	m	30

Connector

Removable spring terminal block	1 rigid cable	mm ² /AWG	0.2... 2.5 / AWG 24... AWG 14
	1 flexible cable	mm ² /AWG	0.2... 2.5 / AWG 24... AWG 14
	1 flexible cable with cable end	mm ² /AWG	0.2... 2.5 / AWG 22... AWG 14

A

B

C

TeSys island Analog I/O module

Dimensions

Analog I/O module: TPRAN2X1

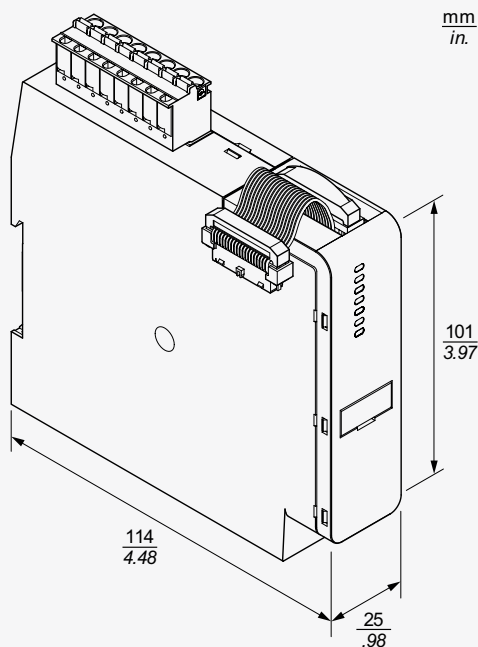

Wiring diagrams

Analog I/O module

Terminals

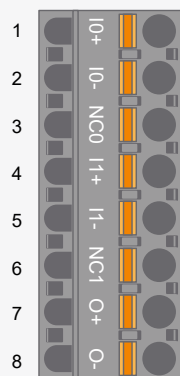

Pin	Terminal Identification	Analog I/O module
1 (Closest to DIN rail)	I0 +	Input 0 +
2	I0 -	Input 0 -
3	NC 0	NC 0
4	I1 +	Input 1 +
5	I1 -	Input 1 -
6	NC 1	NC 1
7	O +	Output +
8 (Closest to front face)	O -	Output -

Analog I/O Wiring

Current / Voltage Analog Device Input

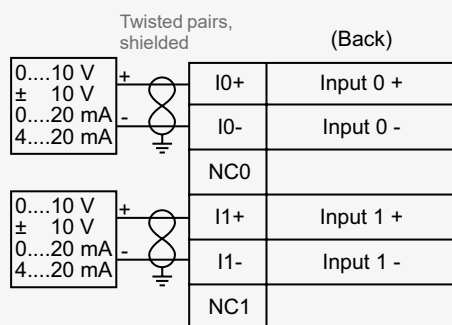

Thermocouples

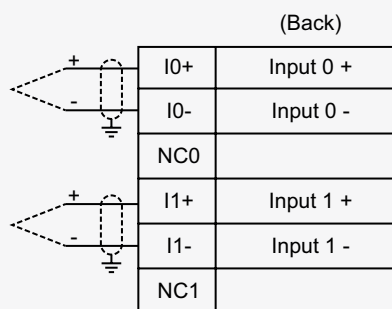

Resistance Temperature Detector

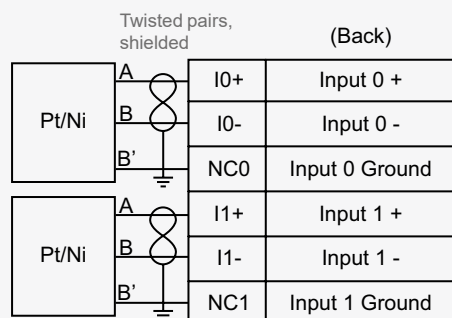

Current / Voltage Analog Device Output

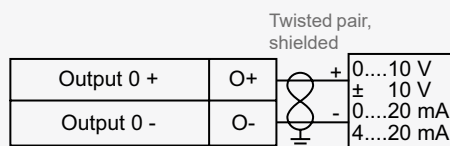

TeSys island Voltage Interface Module Introduction

Voltage Interface Module (VIM), for whole island monitoring



TPRVM001

The voltage interface module (VIM) enables voltage, power, and energy monitoring for the whole island.

Main functions

- Measure single-phase and three-phase line voltages (47...63 Hz) at one connection point of the island
- Enable the monitoring of energy-related data at the island level
- Monitor voltage in single-phase systems L-N or L-L
- Monitor voltages in three-phase systems without neutral N connection
- Calculate RMS phase voltages, voltage phase sequence
- Monitor for fundamental frequency
- Identify the level and duration of dip and swell events.

The VIM is connected

- Upstream to the line voltages.

The VIM communicates with the bus coupler, sending operational data.

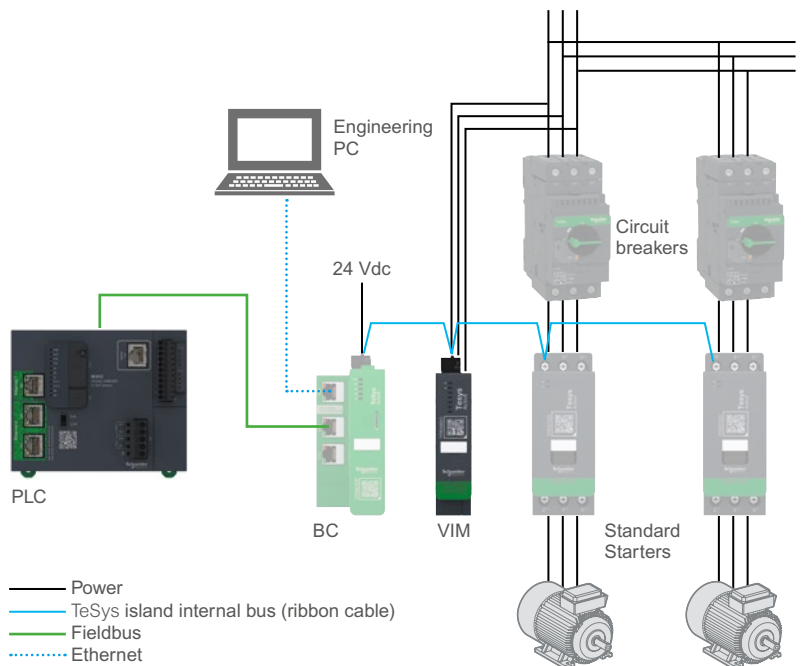
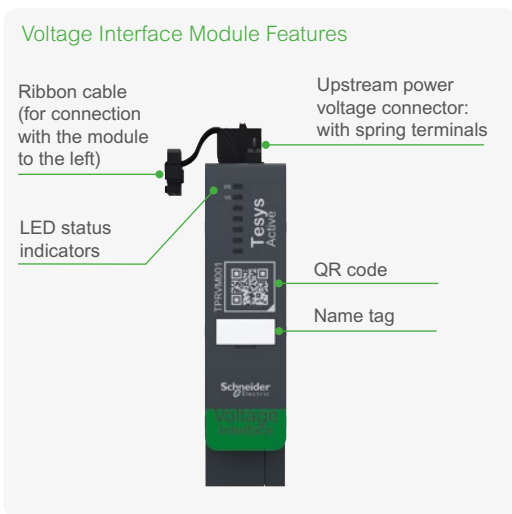

Voltage interface module (VIM) commercial information

Designation	Voltage		Frequency	Product Reference	Weight (kg)
	Phase	(V)	(Hz)		
TeSys island Voltage interface module	1P/3P	100 to 690	50-60	TPRVM001	0.159

TeSys island Voltage Interface Module

Specifications

Voltage interface module Product Reference	TPRVM001
---	-----------------

Standards - Certification

Standards	IEC 61010-02-030, UL 61010-02-030, CSA C22.2 No 61010-02-030
Product certification	UL, CSA, EAC

Function specifications

Functionality		<ul style="list-style-type: none"> • Provides Island line power supply voltage measurement • Values are sent to bus coupler, to enable load monitoring by upper system
Measurement Functions specifications		<ul style="list-style-type: none"> • Voltage monitoring of single-phase (U L-N or U L-L) • 3-phase without neutral (U L1-L2, U L2-L3, U L3-L1) • RMS voltage calculation • Voltage phase sequence • Fundamental frequency • Dip and swell event levels and duration
Voltage measurement range	Vrms	100...690
Voltage measurement accuracy	%	± 5
Frequency measurement range	Hz	47...63
Frequency measurement accuracy	Hz	± 1
Rated insulation voltage according IEC 61010-1 [Ui]	V	690
Rated impulse withstand voltage according IEC 61010-1 [Uimp]	kV	6
Overvoltage category		III
Local signaling		<ul style="list-style-type: none"> • Device status, 1 green/red LED • Voltage status, 1 green/red LED

Environment

Ambient air temperature for storage	°C (°F)	-25...70 (-13...158)
Ambient air temperature for operation	°C (°F)	-10...60 (14...140)
Ambient air humidity for operation	%	5...95
Operating altitude	m (ft)	0...2000 (0...6562) without derating
IP degree of protection		IP20
Pollution degree		2
Protective treatment		TC
Fire resistance	°C (°F)	960 (1760) conforming to UL 94 850 (1562) conforming to IEC 60695-2-1 650 (1202) conforming to IEC 60695-2-12
Vibration resistance	mm	1.5 peak to peak (3...13 Hz) conforming to IEC 60068-2-6 1 gn (13...200 Hz) conforming to IEC 60068-2-6
Authorised mounting modes		Horizontal and vertical, on 35 mm symmetrical DIN rail
Shock resistance		15 gn (duration = 11 ms) conforming to IEC 60068-2-27
Electromagnetic compatibility		<ul style="list-style-type: none"> • Electrostatic discharge at 8 kV air, 6 kV contact conforming to EN/IEC 61000-4-2 level 3 • Radiated RF fields at 10 V/m conforming to EN/IEC 61000-4-3 level 3 • Fast transient immunity test at 4 kV conforming to EN/IEC 61000-4-4 level 4 • Surge immunity test immunity, level 3 (2 kV) conforming to EN/IEC 61000-4-5

Electrical specifications

Rated supply voltage from bus coupler [Us]	Vdc	24
Current consumption on bus coupler	mA	2
Power dissipation	W	0.5

Connector

Removable spring terminal block	1 rigid cable	mm ² /AWG	0.2... 2.5 / AWG 24...AWG 14
	1 flexible cable	mm ² /AWG	0.2... 2.5 / AWG 24...AWG 14
	1 flexible cable with cable end	mm ² /AWG	0.2... 2.5 / AWG 22...AWG 14

TeSys island Voltage Interface Module Dimensions

Voltage Interface Module: TPRVM001

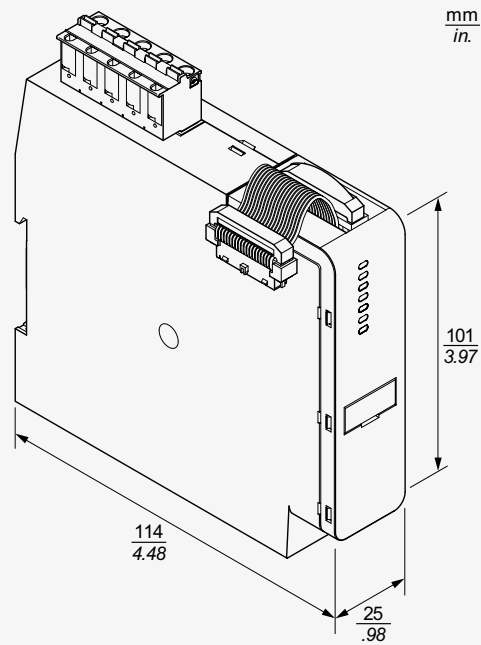

Wiring diagrams

VIM Spring Terminal Connector

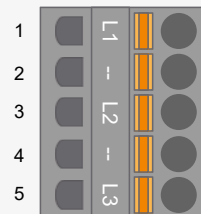

VIM Pinout

Pin Number	Terminal Identification	Single Phase	Three Phase
1	L1	Phase A Voltage	Phase A voltage
2	-	Do Not Use	Do Not Use
3	L2	Do Not Use	Phase B voltage
4	-	Do Not Use	Do Not Use
5	L3	Phase B Voltage	Phase C voltage

TeSys island assembly kits

Introduction

Assembly Kit for 2 speed or 2 direction avatars



LAD9R1

LAD9R1

Kit is used to join adjacent 9-38 A (size 1 and 2) starters.

Composition:

- LAD9V2 - Mechanical interlock with assembly staple
- LAD9V5 - Parallel link between two starters
- LAD9V6 - Reversing link between two starters.

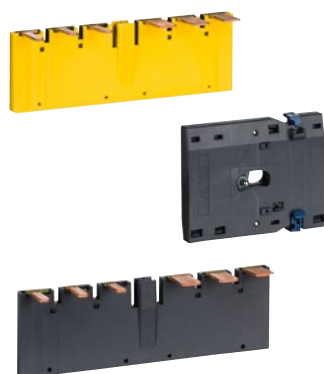
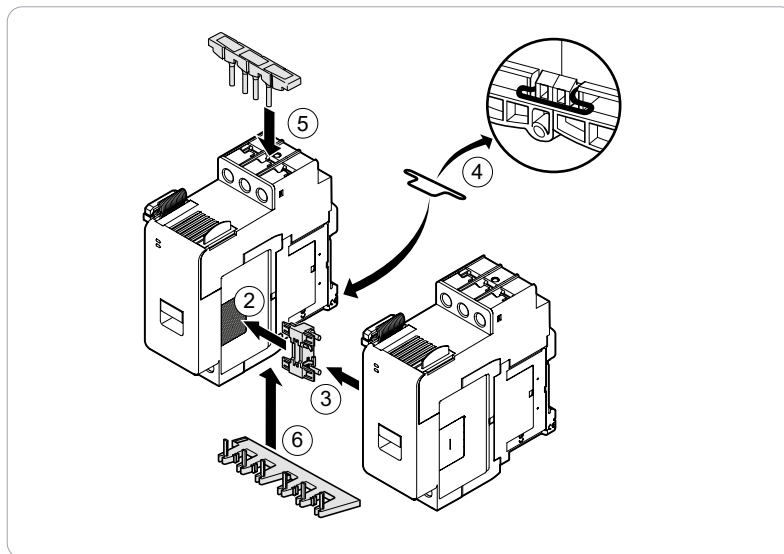

LAD9R3

LAD9R3

Kit is used to join adjacent 40-65 A (size 3) starters.

Composition:

- LAD4CM - Mechanical interlock
- LA9D65A6 - Parallel link between two starters
- LA9D65A9 - Reversing link between two starters.

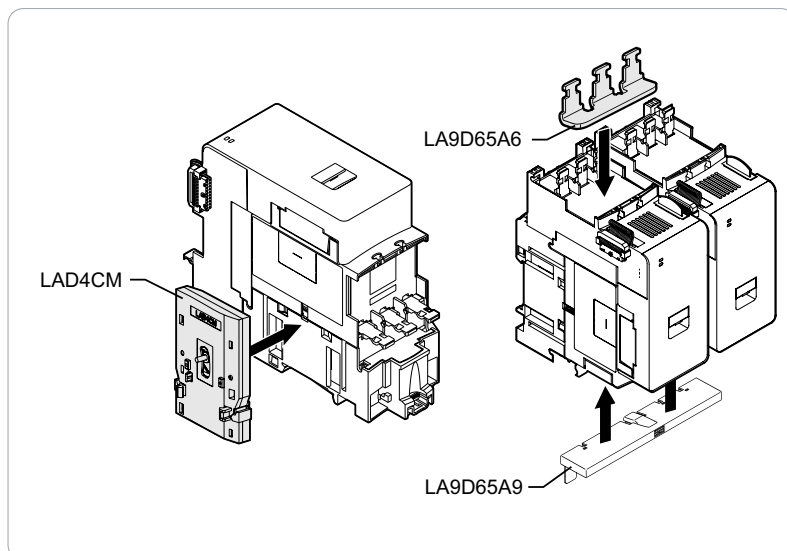

Shorting blocks for Wye-Delta (Star-Delta) avatars



LAD9P3

LAD9P3

Is used for linking 3 poles of a 9-38 A (size 1 and 2) starter.

A

B



LAD9SD3S

LAD9SD3S

Is used for linking 3 poles of a 40-65 A (size 3) starter.

Assembly kits for starters

Designation		Product Reference
Assembly kit for 2 starters	9-38 A (size 1 and 2) starters	LAD9R1
	40-65 A (size 3) starters	LAD9R3
Jumper bar 3-pole	for 9-38 A (size 1 and 2) starter	LAD9P3
	with hazard label - for 40-65 A (size 3) starter	LAD9SD3S

C



TeSys island

Coordination tables

Protection Components / Starters

Coordination – IEC

Type 1 or 2 coordination with fuses – 690 V.....	p. 44
Type 1 coordination with circuit breakers – 230 V.....	p. 45
Type 2 coordination with circuit breakers – 230 V.....	p. 46
Type 1 coordination with circuit breakers 400/415-440-500 V.....	p. 47
Type 2 coordination with circuit breakers 400/415-440-500 V.....	p. 48
Type 1 coordination with circuit breakers – 690 V.....	p. 49
Type 2 coordination with circuit breakers – 690 V.....	p. 50

Protection Components / Starters

SCCR Ratings – UL

Short Circuit Current Ratings (SCCR).....	p. 51
Group Motor Rating	p. 51
Thermal protection tripping curves.....	p. 52

Protection Components / Starters - Coordination – IEC

Type 1 or 2 coordination with fuses

690 V

690 V - Type 1 or 2 coordination with fuses

Applications with 3-phase motors 50-60 Hz in category AC-3	aM fuses	Standard Starters SIL Starters Power Interface Modules	
690 V	Rating	References	Setting range
I _q			
kA	A		A
80	≤10	TPRST009 TPRSS009 TPRPM009	0.18-9
	≤25	TPRST025 TPRSS025	0.5-25
	≤40	TPRST038 TPRSS038 TPRPM038	0.76-38
	≤80	TPRST065 TPRSS065	3.25-65
	≤80	TPRST080 TPRSS080 TPRPM080	4-80

Protection Components / Starters - Coordination – IEC

Type 1 coordination with circuit breakers

230 V

0.06 to 22 kW at 230 V: Type 1 coordination

Applications power ratings of 3-phase motors 50-60 Hz in category AC-3			Circuit breaker (Trip class 5 to 15)	Standard Starters SIL Starters Power Interface Modules	
230 V			References	References	Setting range
P	I _e	I _q			
kW	A	kA			A
0.06	0.35	100	GV2L03	TPRST009 TPRSS009 TPRPM009	0.18-9
0.09	0.52	100	GV2L04	TPRST009 TPRSS009 TPRPM009	0.18-9
0.12	0.7	100	GV2L05	TPRST009 TPRSS009 TPRPM009	0.18-9
0.18	1	100	GV2L06	TPRST009 TPRSS009 TPRPM009	0.18-9
0.25	1.5	100	GV2L06	TPRST009 TPRSS009 TPRPM009	0.18-9
0.37	1.9	100	GV2L07	TPRST009 TPRSS009 TPRPM009	0.18-9
0.55	2.6	100	GV2L08	TPRST009 TPRSS009 TPRPM009	0.18-9
0.75	3.3	100	GV2L08	TPRST009 TPRSS009 TPRPM009	0.18-9
1.1	4.7	100	GV2L10	TPRST009 TPRSS009 TPRPM009	0.18-9
1.5	6.3	100	GV2L14	TPRST009 TPRSS009 TPRPM009	0.18-9
2.2	8.5	100	GV2L14	TPRST009 TPRSS009 TPRPM009	0.18-9
3	11.3	100	GV2L16	TPRST025 TPRSS025 TPRPM038	0.5-25 / 0.76-38
4	15	100	GV2L20	TPRST025 TPRSS025 TPRPM038	0.5-25 / 0.76-38
5.5	20	50	GV2L22	TPRST025 TPRSS025 TPRPM038	0.5-25 / 0.76-38
7.5	27	50	GV2L32	TPRST038 TPRSS038 TPRPM038	0.76-38
9	32	100	GV3L40	TPRST038 TPRSS038 TPRPM038	0.76-38
11	38	100	GV3L40	TPRST065 TPRSS065 TPRPM080	3.25-65 / 4-80
15	51	100	GV3L65	TPRST065 TPRSS065 TPRPM080	3.25-65 / 4-80
18.5	61	100	GV3L65	TPRST065 TPRSS065 TPRPM080	3.25-65 / 4-80
22	72	100	GV3L73	TPRPM080	4-80

A

B

C

Protection Components / Starters - Coordination – IEC

Type 2 coordination with circuit breakers

230 V

0.06 to 22 kW at 230 V: Type 2 coordination

Applications power ratings of 3-phase motors 50-60 Hz in category AC-3			Circuit breaker (Trip class 5 to 15)	Standard Starters SIL Starters	
230 V			References	References	Setting range
P	I _e	I _q			
kW	A	kA			A
0.06	0.35	100	GV2L03	TPRST009 TPRSS009	0.18-9
0.09	0.52	100	GV2L04	TPRST009 TPRSS009	0.18-9
0.12	0.7	100	GV2L05	TPRST009 TPRSS009	0.18-9
0.18	1	100	GV2L06	TPRST009 TPRSS009	0.18-9
0.25	1.5	100	GV2L06	TPRST009 TPRSS009	0.18-9
0.37	1.9	100	GV2L07	TPRST009 TPRSS009	0.18-9
0.55	2.6	100	GV2L08	TPRST009 TPRSS009	0.18-9
0.75	3.3	100	GV2L08	TPRST025 TPRSS025	0.5-25
1.1	4.7	100	GV2L10	TPRST025 TPRSS025	0.5-25
1.5	6.3	100	GV2L14	TPRST025 TPRSS025	0.5-25
2.2	8.5	100	GV2L14	TPRST025 TPRSS025	0.5-25
3	11.3	100	GV2L16	TPRST025 TPRSS025	0.5-25
4	15	100	GV2L20	TPRST025 TPRSS025	0.5-25
5.5	20	50	GV2L22	TPRST025 TPRSS025	0.5-25
7.5	27	50	GV2L32	TPRST038 TPRSS038	0.76-38
9	32	100	GV3L40	TPRST038 TPRSS038	0.76-38
11	38	100	GV3L40	TPRST065 TPRSS065	3.25-65
15	51	100	GV3L65	TPRST065 TPRSS065	3.25-65
18.5	61	100	GV3L65	TPRST065 TPRSS065	3.25-65

Protection Components / Starters - Coordination – IEC

Type 1 coordination with circuit breakers

400/415 - 440 - 500 V

0.06 to 37 kW at 400/415 - 440 - 500 V: Type 1 coordination

Applications power ratings of 3-phase motors 50-60 Hz in category AC-3									Circuit breaker (Trip class 5 to 15)	Standard Starters SIL Starters Power Interface Modules	
400/415 V			440 V			500 V			References	References	Setting range
P	I _e	I _q	P	I _e	I _q	P	I _e	I _q			A
kW	A	kA	kW	A	kA	kW	A	kA			
0.06	0.2	100	0.06	0.18	100	-	-	-	GV2L03	TPRST009 TPRSS009 TPRPM009	0.18-9
0.09	0.3	100	0.09	0.27	100	-	-	-			
0.12	0.44	100	0.12	0.4	100	-	-	-	GV2L04	TPRST009 TPRSS009 TPRPM009	0.18-9
0.18	0.6	100	0.18	0.55	100	-	-	-			
0.25	0.85	100	0.25	0.77	100	-	-	-	GV2L05	TPRST009 TPRSS009 TPRPM009	0.18-9
0.37	1.1	100	-	-	-	0.37	0.88	100			
-	-	-	0.37	1	100	-	-	-	GV2L06	TPRST009 TPRSS009 TPRPM009	0.18-9
0.55	1.5	100	0.55	1.4	100	0.55	1.2	100			
-	-	-	-	-	-	0.75	1.5	100	GV2L07	TPRST009 TPRSS009 TPRPM009	0.18-9
0.75	1.9	100	0.75	1.7	100	-	-	-			
1.1	2.7	100	-	-	-	1.1	2.2	100	GV2L08	TPRST009 TPRSS009 TPRPM009	0.18-9
-	-	-	1.1	2.4	100	-	-	-			
1.5	3.6	100	1.5	3.3	100	1.5	2.9	100	GV2L10	TPRST009 TPRSS009 TPRPM009	0.18-9
2.2	4.9	100	2.2	4.5	100	2.2	3.9	100			
-	-	-	3	5.9	100	3	5.2	100	GV2L14	TPRST009 TPRSS009 TPRPM009	0.18-9
3	6.5	100	-	-	-	-	-	-			
4	8.5	100	4	7.7	20	4	6.8	10	GV2L16	TPRST025 TPRSS025 TPRPM038	0.5-25 / 0.76-38
-	-	-	-	-	-	5.5	9.2	10			
5.5	11.5	50	5.5	10.5	20	-	-	-	GV2L20	TPRST025 TPRSS025 TPRPM038	0.5-25 / 0.76-38
-	-	-	-	-	-	7.5	12.4	10			
7.5	15.5	50	7.5	14.1	20	-	-	-	GV2L22	TPRST025 TPRSS025 TPRPM038	0.5-25 / 0.76-38
-	-	-	9	16.5	20	9	13.9	10			
9	18.1	50	-	-	-	-	-	-	GV2L32	TPRST038 TPRSS038 TPRPM038	0.76-38
11	22	50	11	20	20	11	17.6	10			
-	-	-	-	-	-	15	23	10	GV3L40	TPRST065 TPRSS065 TPRPM080	3.25-65 / 4-80
15	29	50	15	26.4	20	-	-	-			
-	-	-	-	-	-	18.5	28	10	GV3L50	TPRST065 TPRSS065 TPRPM080	3.25-65 / 4-80
18.5	35	50	18.5	31.8	50	-	-	-			
-	-	-	-	-	-	22	33	12	GV3L65	TPRST065 TPRSS065 TPRPM080	3.25-65 / 4-80
22	41	50	22	37.3	50	-	-	-			
-	-	-	-	-	-	30	44	12	GV3L73	TPRST065 TPRSS065 TPRPM080	3.25-65 / 4-80
30	55	50	30	50	50	-	-	-			
-	-	-	37	60	50	37	53	12			
37	66	50	-	-	-	-	-	-			

A

B

C

Protection Components / Starters - Coordination – IEC

Type 2 coordination with circuit breakers

400/415 - 440 - 500 V

0.06 to 37 kW at 400/415 - 440 - 500 V: Type 2 coordination

Applications power ratings of 3-phase motors 50-60 Hz in category AC-3									Circuit breaker (Trip class 5 to 15)	Standard Starters SIL Starters	
400/415 V			440 V			500 V			References	References	Setting range
P	I _e	I _q	P	I _e	I _q	P	I _e	I _q			A
kW	A	kA	kW	A	kA	kW	A	kA			
0.06	0.2	100	0.06	0.18	100	-	-	-	GV2L03	TPRST009 TPRSS009	0.18-9
0.09	0.3	100	0.09	0.27	100	-	-	-			
0.12	0.44	100	0.12	0.4	100	-	-	-	GV2L04	TPRST009 TPRSS009	0.18-9
0.18	0.6	100	0.18	0.55	100	-	-	-			
0.25	0.85	100	0.25	0.77	100	-	-	-	GV2L05	TPRST009 TPRSS009	0.18-9
0.37	1.1	100	-	-	-	0.37	0.88	100			
-	-	-	0.37	1	100	-	-	-	GV2L06	TPRST009 TPRSS009	0.18-9
0.55	1.5	100	0.55	1.4	100	0.55	1.2	100			
-	-	-	-	-	-	0.75	1.5	100	GV2L07	TPRST009 TPRSS009	0.18-9
0.75	1.9	100	0.75	1.7	100	-	-	-			
						1.1	2.2	100			
1.1	2.7	100	-	-	-	-	-	-	GV2L07	TPRST025 TPRSS025	0.5-25
-	-	-	1.1	2.4	100	-	-	-	GV2L08	TPRST009 TPRSS009	0.18-9
-	-	-	-	-	-	1.5	2.9	100			
1.5	3.6	100	1.5	3.3	100	-	-	-	GV2L08	TPRST025 TPRSS025	0.5-25
2.2	4.9	100	2.2	4.5	100	2.2	3.9	100	GV2L10	TPRST025 TPRSS025	0.5-25
-	-	-	3	5.9	100	3	5.2	100			
3	6.5	100	-	-	-	-	-	-	GV2L14	TPRST025 TPRSS025	0.5-25
4	8.5	100	4	7.7	20	4	6.8	10			
-	-	-	-	-	-	5.5	9.2	10			
5.5	11.5	50	5.5	10.5	20	-	-	-	GV2L16	TPRST025 TPRSS025	0.5-25
-	-	-	-	-	-	7.5	12.4	10			
7.5	15.5	50	7.5	14.1	20	-	-	-	GV2L20	TPRST025 TPRSS025	0.5-25
-	-	-	9	16.5	20	9	13.9	10			
9	18.1	50	-	-	-	-	-	-	GV2L22	TPRST025 TPRSS025	0.5-25
11	22	50	11	20	20	11	17.6	10			
-	-	-	-	-	-	15	23	10			
15	29	50	15	26.4	20	-	-	-	GV2L32	TPRST038 TPRSS038	0.76-38
-	-	-	-	-	-	18.5	28	10			
18.5	35	50	18.5	31.8	50	-	-	-	GV3L40	TPRST065 TPRSS065	3.25-65
-	-	-	-	-	-	22	33	12			
22	41	50	22	37.3	50	-	-	-	GV3L50	TPRST065 TPRSS065	3.25-65
-	-	-	-	-	-	30	44	12			
30	55	50	30	50	50	-	-	-	GV3L65	TPRST065 TPRSS065	3.25-65
-	-	-	37	60	50	37	53	12			
37	66	50	-	-	-	-	-	-	GV3L73	TPRST065 TPRSS065	3.25-65

Protection Components / Starters - Coordination – IEC

Type 1 coordination with circuit breakers

690 V

0.06 to 37 kW at 690 V: Type 1 coordination

Applications power ratings of 3-phase motors 50-60 Hz in category AC-3			Circuit breaker (Trip class 5 to 15)	Standard Starters SIL Starters Power Interface Modules
690 V			References	References Setting range
P	I _e	I _q		
kW	A	kA		A
0.37	0.64	100	GV2L05	TPRST009 TPRSS009 TPRPM009 0.18-9
0.55	0.87	4	GV2L05	TPRST009 TPRSS009 TPRPM009 0.18-9
0.75	1.1	4	GV2L06	TPRST009 TPRSS009 TPRPM009 0.18-9
1.1	1.6	4	GV2L07	TPRST009 TPRSS009 TPRPM009 0.18-9
1.5	2.1	4	GV2L07	TPRST009 TPRSS009 TPRPM009 0.18-9
2.2	2.8	4	GV2L08	TPRST009 TPRSS009 TPRPM009 0.18-9
3	3.8	4	GV2L08	TPRST009 TPRSS009 TPRPM009 0.18-9
4	4.9	4	GV2L10	TPRST009 TPRSS009 TPRPM009 0.18-9
5.5	6.7	4	GV2L14	TPRST009 TPRSS009 TPRPM009 0.18-9
7.5	8.9	4	GV2L14	TPRST025 TPRSS025 TPRPM038 0.5-25 / 0.76-38
9	10.5	4	GV2L16	TPRST025 TPRSS025 TPRPM038 0.5-25 / 0.76-38
11	12.8	4	GV2L16	TPRST025 TPRSS025 TPRPM038 0.5-25 / 0.76-38
15	17	4	GV2L20	TPRST025 TPRSS025 TPRPM038 0.5-25 / 0.76-38
18.5	21	4	GV2L22	TPRST038 TPRSS038 TPRPM038 0.76-38
22	24	4	GV2L22	TPRST065 TPRSS065 TPRPM080 3.25-65 / 4-80
30	32	6	GV3L40	TPRST065 TPRSS065 TPRPM080 3.25-65 / 4-80
37	39	6	GV3L50	TPRST065 TPRSS065 TPRPM080 3.25-65 / 4-80

A

B

C

Protection Components / Starters - Coordination – IEC

Type 2 coordination with circuit breakers

690 V

0.06 to 37 kW at 690 V: Type 2 coordination

Applications power ratings of 3-phase motors 50-60 Hz in category AC-3			Circuit breaker (Trip class 5 to 15)	Standard Starters SIL Starters	
690 V			References	References	Setting range
P	I _e	I _q			
kW	A	kA			A
0.37	0.64	100	GV2L05	TPRST009 TPRSS009	0.18-9
0.55	0.87	4	GV2L05	TPRST009 TPRSS009	0.18-9
0.75	1.1	4	GV2L06	TPRST009 TPRSS009	0.18-9
1.1	1.6	4	GV2L07	TPRST009 TPRSS009	0.18-9
1.1	1.6	50	GV2L07 + LA9LB920	TPRST025 TPRSS025	0.5-25
1.5	2.1	4	GV2L07	TPRST009 TPRSS009	0.18-9
1.5	2.1	50	GV2L07 + LA9LB920	TPRST025 TPRSS025	0.5-25
2.2	2.8	4	GV2L08	TPRST025 TPRSS025	0.5-25
2.2	2.8	50	GV2L08 + LA9LB920	TPRST025 TPRSS025	0.5-25
3	3.8	4	GV2L08	TPRST025 TPRSS025	0.5-25
3	3.8	50	GV2L08 + LA9LB920	TPRST025 TPRSS025	0.5-25
4	4.9	4	GV2L10	TPRST025 TPRSS025	0.5-25
4	4.9	50	GV2L10 + LA9LB920	TPRST025 TPRSS025	0.5-25
5.5	6.7	4	GV2L14	TPRST025 TPRSS025	0.5-25
5.5	6.7	50	GV2L14 + LA9LB920	TPRST025 TPRSS025	0.5-25
7.5	8.9	4	GV2L14	TPRST025 TPRSS025	0.5-25
7.5	8.9	50	GV2L14 + LA9LB920	TPRST025 TPRSS025	0.5-25
9	10.5	4	GV2L16	TPRST025 TPRSS025	0.5-25
11	12.8	4	GV2L16	TPRST025 TPRSS025	0.5-25
15	17	4	GV2L20	TPRST025 TPRSS025	0.5-25
15	17	3	GV2L22 + LA9LB920	TPRST038 TPRSS038	0.76-38
18.5	21	4	GV2L22	TPRST038 TPRSS038	0.76-38
18.5	21	3	GV2L25 + LA9LB920	TPRST065 TPRSS065	3.25-65
22	24	4	GV2L22	TPRST065 TPRSS065	3.25-65
22	24	3	GV2L32 + LA9LB920	TPRST065 TPRSS065	3.25-65
30	32	6	GV3L40	TPRST065 TPRSS065	3.25-65
37	39	6	GV3L50	TPRST065 TPRSS065	3.25-65

Protection Components / Starters – SCCR Ratings – UL

Short Circuit Current Ratings (SCCR)

UL File E39281 and File E48539 Suitable for use on a circuit delivering not more than:								Standard Starters SIL Starters Power Interface Modules	
High SCCR						Standard SCCR		References	Setting range
Max Voltage 600 V Class J Fuse ⁽¹⁾		Max Voltage 480 V Circuit Breaker		Max Voltage 600 V Circuit Breaker		Max Voltage 600 V Circuit Breaker or Fuse			
SCCR	Maximum Amperage	SCCR	Maximum Amperage	SCCR	Maximum Amperage	SCCR	Maximum Amperage		
kA	A	kA	A	kA	A	kA	A		A
100	25	85	35	50	35	5	35	TPRST009 TPRSS009 TPRPM009	0.18-9
100	60	85	60	50	60	5	100	TPRST025 TPRSS025	0.5-25
100	100	85	60	50	60	5	125	TPRST038 TPRSS038 TPRPM038	0.76-38
100	125	85	110	50	110	5	250	TPRST065 TPRSS065	3.25-65
100	125	85	110	50	110	5	250	TPRST080 TPRSS080 TPRPM080	4-80

(1) When protected by any Class J or CC time-delay fuse (Class CC applicable up to 30 A only).

Group Motor Rating

Suitable for group installation on a circuit delivering not more than:				Standard Starters SIL Starters	
Max voltage 600 V - Class J Fuse ⁽¹⁾		Max voltage 480 V - Circuit Breaker		References	Setting range
SCCR	Maximum Amperage	SCCR	Maximum Amperage		
kA	A	kA	A		A
5	90	5	90	TPRST009 TPRSS009	0.18-9
5	175	5	175	TPRST025 TPRSS025	0.5-25
5	175	5	175	TPRST038 TPRSS038	0.76-38
5	600	5	600	TPRST065 TPRSS065	3.25-65
5	600	5	600	TPRST080 TPRSS080	4-80

(1) When protected by any Class J or CC time-delay fuse.

A

B

C

Thermal Protection Tripping Curves

TeSys island Cold State Tripping Curves

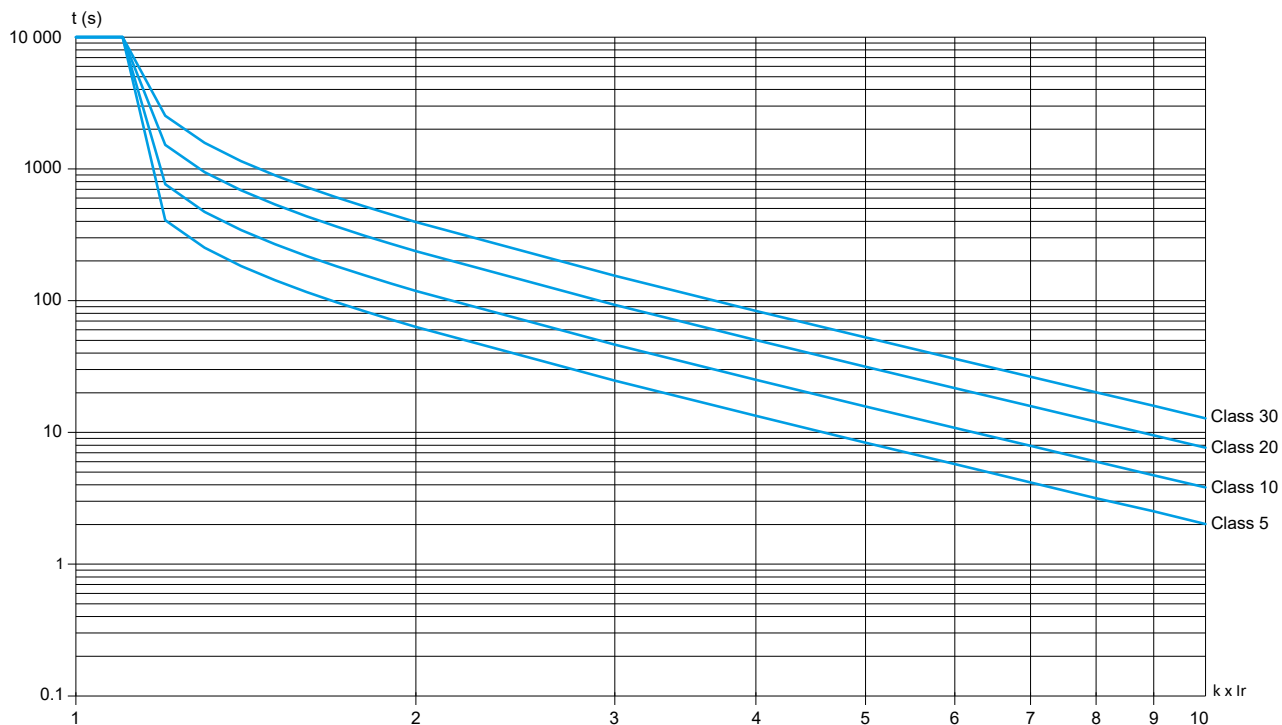

TeSys island Hot State Tripping Curves

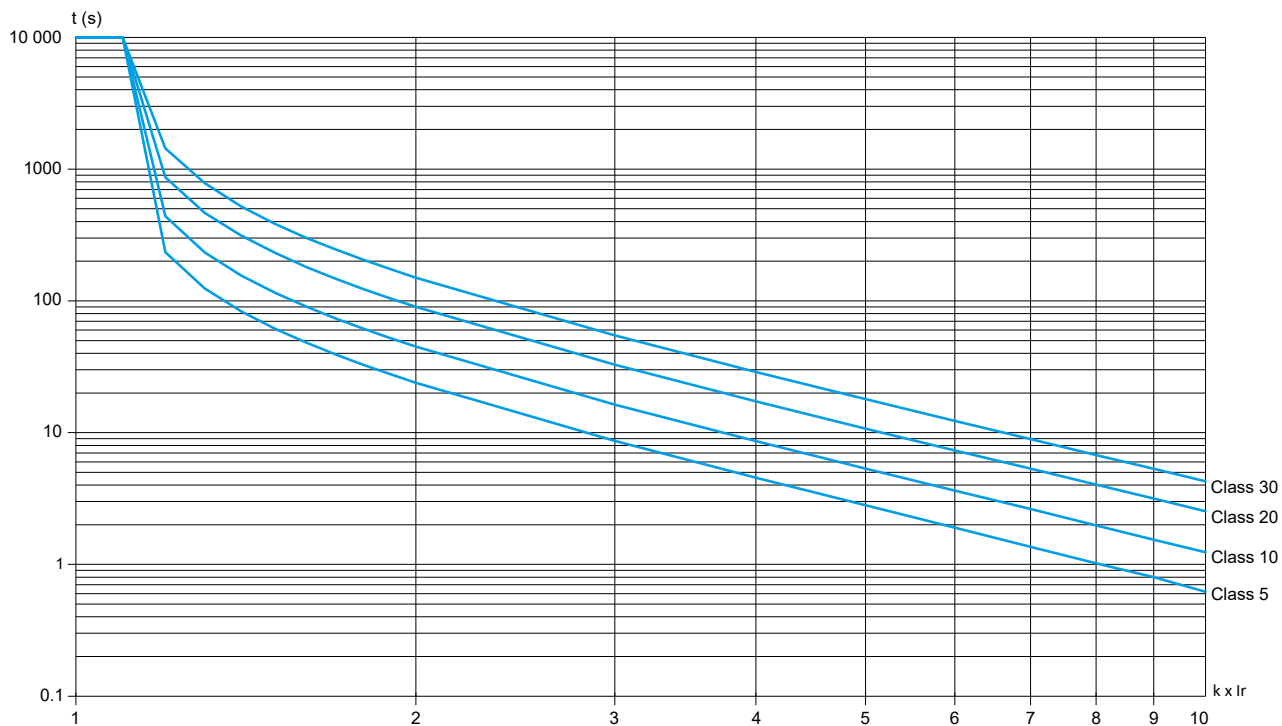

Document Title	Description	Document Number
Guide		
TeSys island - System, Installation, and Operation Guide	Introduces and describes the main functions of TeSys island. Describes its mechanical installation, wiring, and commissioning. Describes how to operate and maintain TeSys island.	DOCA0270EN
TeSys island - Functional Safety Guide	Describes the Functional Safety features ⁽¹⁾ of TeSys island	8536IB1904EN
TeSys island - Third Party Function Block Guide	Contains the information needed to create function blocks for third party hardware	8536IB1905EN
TeSys island - Quick Start & Library Guide for Ethernet IP in Studio 5000 Application	Describes the TeSys island library used in the Studio 5000 environment with a Rockwell EtherNet/IP PLC	DOCA0271EN
TeSys island - Quick Start & Library Guide for PROFIBUS & PROFINET in TIA Portal	Describes the TeSys island library used in the Studio 5000 environment with a PLC using PROFINET or PROFIBUS communication	DOCA0272EN
TeSys island DTM Online Help Guide	Describes how to install and use various functions of TeSys island configuration software and how to configure the parameters of TeSys island	8536IB1907
Product Environmental Profile		
PEP-TeSys island - Digital multifunctional load management solution up to 80 A	Describes constituent materials, recyclability potential, and environmental impact information for TeSys island	ENVPEP1904009EN
Product End of Life Instructions		
EoLI-TeSys island - Digital multifunctional load management solution up to 80 A	Contains end of life instructions for TeSys island	ENVEOLI1904009EN
Instruction Sheet		
TeSys island TPRBCPFN Bus Coupler (PROFINET) - Instruction Sheet	Describes how to install the TeSys island PROFINET Bus Coupler	MFR44098
TeSys island TPRBCPFB Bus Coupler (PROFIBUS) - Instruction Sheet	Describes how to install the TeSys island PROFIBUS Bus Coupler	GDE55148
TeSys island TPRBCEIP Bus Coupler (Ethernet IP) - Instruction Sheet	Describes how to install the TeSys island Modbus TCP Bus Coupler	MFR44097
TeSys island Starters and Power Interface Modules, Size 1 and 2 - Instruction Sheet	Describes how to install Size 1 and 2 TeSys island starters and power interface modules	MFR77070
TeSys island Starters and Power Interface Modules, Size 3 - Instruction Sheet	Describes how to install Size 3 TeSys island starters and power interface modules	MFR77085
TeSys island Analog I/O and Digital I/O Modules - Instruction Sheet	Describes how to install the TeSys island analog and digital I/O modules	MFR44099
TeSys island SIL Interface and Voltage Interface Modules - Instruction Sheet	Describes how to install the TeSys island voltage interface modules and SIL interface modules	MFR44100

(1) Functional Safety according to EN 61508



Green Premium™

An industry leading portfolio of offers delivering sustainable value



More than 75% of our product sales offer superior transparency on the material content, regulatory information and environmental impact of our products:

- RoHS compliance
- REACH substance information
- Industry leading # of PEP's*
- Circularity instructions

The Green Premium program stands for our commitment to deliver customer valued sustainable performance. It has been upgraded with recognized environmental claims and extended to cover all offers including Products, Services and Solutions.

CO₂ and P&L impact through... Resource Performance

Green Premium brings improved resource efficiency throughout an asset's lifecycle. This includes efficient use of energy and natural resources, along with the minimization of CO₂ emissions.

Cost of ownership optimization through... Circular Performance

We're helping our customers optimize the total cost of ownership of their assets. To do this, we provide IoT-enabled solutions, as well as upgrade, repair, retrofit, and remanufacture services.

Peace of mind through... Well-being Performance

Green Premium products are RoHS and REACH compliant. We're going beyond regulatory compliance with step-by-step substitution of certain materials and substances from our products.

Improved sales through... Differentiation

Green Premium delivers strong value propositions through third-party labels and services. By collaborating with third-party organizations we can support our customers in meeting their sustainability goals such as green building certifications.



Discover what we mean by green
Check your products!

*PEP: Product Environmental Profile (i.e. Environmental Product Declaration)



Schneider Electric Industries SAS

35, rue Joseph Monier
CS 30323
92506 Rueil Malmaison Cedex (France)

RCS Nanterre 954 503 439
Capital social 896 313 776 €
www.se.com

09-2023
LVCATISL_EN

© 2023 - Schneider Electric - All rights reserved.
Schneider Electric, Life Is On Schneider Electric, and TeSys are trademarks and the property of Schneider Electric SE, its subsidiaries, and affiliated companies. All other trademarks are the property of their respective owners.

This document has been
printed on recycled paper.

