

---

# Inductive proximity sensors

## XS range

## Catalogue





# Inductive proximity sensors

## XS range

---

**Selection guide** ..... *page 2*

- General ..... *page 12*
- Flush mountability using teach mode:  
Simplicity through innovation ..... *page 22*

### XS range, general purpose

- Cylindrical type
  - Standard range, flush mountable ..... *page 24*
  - Increased range, flush mountable ..... *page 34*
  - Increased range, non-flush mountable ..... *page 42*
- Block type, flat format
  - Standard range, flush mountable ..... *page 48*
  - Increased range, flush mountable using teach mode ..... *page 52*
- Cubic type
  - 40 x 40 x 70 mm format, flush or non-flush mountable ..... *page 54*
  - 40 x 40 x 117 mm format, flush or non-flush mountable ..... *page 56*
- Multivoltage sensors with short-circuit protection ..... *page 58*
- Sensors with 2 complementary outputs
  - Solid-state PNP or NPN, NO + NC outputs ..... *page 60*
  - Solid-state PNP + NPN, NO or NC programmable outputs ..... *page 66*
- Plastic case sensors ..... *page 68*  
(also for chemical processing, marine applications)
- Quasi-flush mountable sensors, increased range ..... *page 70*
- Miniature sensors ..... *page 72*

### XS range, application

- Adjustable range sensors ..... *page 76*
- Sensors for rotation monitoring, slip and shaft overload detection ..... *page 78*
- Sensors with analogue output ..... *page 82*
- Sensors for food & beverage and pharmaceutical applications
  - Cubic, plastic ..... *page 90*
  - Cylindrical, stainless steel ..... *page 92*
  - Cylindrical, plastic ..... *page 98*
  - Cylindrical, stainless steel, for harsh industrial environments ..... *page 102*
- Sensors for assembly, packaging and light material handling applications
  - 80 x 80 x 40 mm format ..... *page 104*
- Sensors for welding machine applications ..... *page 106*

### XS range, Fail Safe

- Cylindrical type ..... *page 112*
  - Standard range ..... *page 112*
  - Increased range ..... *page 114*
- Cubic type ..... *page 116*
  - 40 x 40 x 70 mm format ..... *page 116*
  - 40 x 40 x 117 mm format ..... *page 118*

### XS range

- Accessories ..... *page 120*
- Detection curves ..... *page 122*
- Substitution table ..... *page 126*
- **Product reference index** ..... *page 132*

#### Cylindrical type

#### Standard range

Flush mountable



<b>Sensing distance Sn (mm)</b>	
<b>Diameter</b>	
<b>Short case</b>	Supply 3-wire $\overline{\text{---}}$ (PNP/NPN) 2-wire $\overline{\text{---}}$
<b>Long case</b>	Supply 3-wire $\overline{\text{---}}$ (PNP/NPN) 2-wire $\overline{\text{---}}$ 2-wire $\sim$
<b>Function</b>	NO NC
<b>Connection</b>	Pre-cabled (L = 2 m) (1) M8 connector, 3-pin (3-wire $\overline{\text{---}}$ ) M12 connector 1/2"-20UNF connector Remote connector
<b>Degree of protection</b>	
<b>Special temperatures</b>	- 40 °C, + 70 °C - 25 °C, + 85 °C
<b>Type reference</b>	
<b>Pages</b>	

<b>1.5</b>	<b>2</b>	<b>5</b>	<b>10</b>
Ø 6.5 plain and M8	M12	M18	M30

Page 24			
Page 28			
Page 25			
Page 29			
–	Page 32		
•	•	•	•
•	•	•	•
•	•	•	•
•	–	–	–
•	•	•	•
–	•	•	•
Remote connectors available: M8, M12, M18, screw terminal, 7/8", DIN: please consult our Customer Care Centre			
IP 65 and IP 67, IP 68 for pre-cabled version, IP 69K for diameters 12 to 30 (2)			
Add the suffix TF to the end of the reference (3)			
Add the suffix TT to the end of the reference (3)			

<b>XS506</b>	<b>XS508</b>	<b>XS512</b>	<b>XS518</b>	<b>XS530</b>
--------------	--------------	--------------	--------------	--------------

24 to 33

(1) Also available in lengths of 5 and 10 m, depending on model  
 (2) For M12 connector version  
 (3) Product availability depending on model: please consult our Customer Care Centre.

## Increased range

Flush mountable

Non-flush mountable



2.5	4	8	15	4	7	8	12	16	22	30
Ø 6.5 plain and M8	M12	M18	M30	M8	M12		M18		M30	
Pages 34 and 35				-	-	Page 44	-	Page 44	-	-
Page 38				-	-	-	-	-	-	-
Page 36				Page 42	Page 42	-	Page 42	-	-	Page 42
Page 38				-	-	-	-	-	-	-
-	Page 40			-	-	-	Page 46	-	Page 46	-
•	•	•	•	•	•	•	•	•	•	•
•	•	•	•	•	•	•	•	•	•	•
•	•	•	•	•	•	•	•	•	•	•
•	-	-	-	•	-	-	-	-	-	-
•	•	•	•	-	•	•	•	•	•	•
-	•	•	•	-	-	-	•	-	•	-
Remote connectors available: M8, M12, M18, screw terminal, 7/8", DIN: please consult our Customer Care Centre										
IP 65 and IP 67, IP 68 for pre-cabled version, IP 69K for diameters 12 to 30 (2)				IP 65 and IP 67, IP 68 for pre-cabled version, IP 69K for diameters 12 to 30 (2)						
Add the suffix TF to the end of the reference (3)										
Add the suffix TT to the end of the reference (3)										
XS106 XS606 XS108 XS608	XS112 XS612	XS118 XS618	XS130 XS630	XS608	XS612	XS212	XS618	XS218	XS630	
34 to 41				42 to 47						

# Inductive proximity sensors

XS range

General purpose

**Block type (flat format) and cubic type**

**Standard range**

Flush mountable



<b>Sensing distance Sn (mm)</b>	
<b>Dimensions (W x H x D)</b>	
<b>Supply</b>	3-wire $\overline{\text{---}}$ (PNP/NPN) 2-wire $\overline{\text{---}}$ $\overline{\text{---}}$
<b>Function</b>	NO NC NO + NC NO/NC
<b>Connection</b>	Pre-cabled (L = 2 m) (1) M8 connector, 3-pin (3-wire $\overline{\text{---}}$ ) M12 connector 1/2"-20UNF connector Screw terminals Remote connector M8 M12 1/2"-20 UNF Other remote connectors available
<b>Degree of protection</b>	
<b>Special temperatures</b>	- 40 °C, + 70 °C - 25 °C, + 85 °C
<b>Type reference</b>	
<b>Pages</b>	

	2.5	5	10	15	40
<b>Dimensions (W x H x D)</b>	8 x 22 x 8	15 x 32 x 8	26 x 26 x 13	40 x 40 x 15	80 x 80 x 26
Page 48	Page 48	Page 50	Page 50	Page 50	Page 50
Page 48	Page 48	Page 50	Page 50	Page 50	Page 50
–	–	–	–	–	–
•	•	•	•	•	•
•	•	•	•	•	•
•	•	•	–	–	–
•	•	•	–	–	–
•	•	•	•	•	•
–	–	•	•	–	–
–	•	•	–	•	–
–	•	•	–	–	–
–	•	•	–	–	–
•	•	•	–	–	–
–	–	•	•	–	–
–	–	–	–	–	–
M18, screw terminal, 7/8", DIN: please consult our Customer Care Centre					
IP 67	IP 67 or IP 68, depending on model				
Add the suffix TF to the end of the reference (2)					
Add the suffix TT to the end of the reference (2)					
<b>XS7J</b>	<b>XS7F</b>	<b>XS7E</b>	<b>XS7C</b>	<b>XS7D</b>	
48	50				

(1) Also available in lengths of 5 and 10 m, depending on model.

(2) Product availability depending on model: please consult our Customer Care Centre.



# Inductive proximity sensors

XS range

General purpose

**Sensor type: flush and non-flush mountable**

**Multivoltage sensors**      **Sensors with 2 complementary outputs**

With short-circuit protection      Solid-state PNP or NPN NO + NC outputs      Solid-state PNP + NPN, NO or NC programmable outputs



<b>Sensing distance Sn (mm)</b>	Flush mountable Quasi flush mountable Non-flush mountable
<b>Diameter</b>	
<b>Case material</b>	
<b>Supply</b>	⋮ ~ ⌒
<b>Function</b>	NO NC NO + NC NO/NC
<b>Connection</b>	Pre-cabled (L = 2 m) (1) M8 connector, 3-pin (3-wire ⋮) M12 connector 1/2"-20UNF connector Remote connector
<b>Degree of protection</b>	
<b>Special temperatures</b>	- 40 °C, + 70 °C - 25 °C, + 85 °C
<b>Type reference</b>	
<b>Pages</b>	

2 ... 10	1.5 ... 15	2 ... 10
–	–	–
<b>4 ... 15</b>	<b>2.5 ... 15</b>	<b>4 ... 15</b>
Threaded: M12, M18, M30	Plain: Ø 6.5 Threaded: M8, M12, M18, M30	Threaded: M12, M18, M30
Nickel plated brass	Nickel plated brass or stainless steel or plastic	Nickel plated brass or plastic
–	•	•
–	–	–
•	–	–
•	–	–
•	–	–
–	•	–
–	–	• programmable
•	•	•
–	–	–
–	•	•
•	–	–
Remote connectors available: M8, M12, M18, screw terminal, 7/8", DIN: please consult our Customer Care Centre		
IP 67, IP 68 or IP 69K depending on model		
Add the suffix TF to the end of the reference (2)		
Add the suffix TT to the end of the reference (2)		
<b>XS1M</b> <b>XS2M</b>	<b>XS1••••C410</b> <b>XS4P••••C410</b> <b>XS1•••B3PC•</b>	<b>XS1M••KP340</b> <b>XS2M••KP340</b> <b>XS4P••KP340</b>
58	60 and 64	66

(1) Also available in lengths of 5 and 10 m, depending on model.

(2) Product availability depending on model: please consult our Customer Care Centre.

Plastic case sensors	Basic sensors	Almost flush mountable sensors	Miniature sensors
For chemical processing, marine applications	For repetitive machines		For robotic, transfer machine, assembly line applications



–	1.5 ... 10	2.5 ... 15	–	–
–	–	–	–	0 ... 0.65    0 ... 1.21
2.5 ... 15	2.5 ... 15	–	2.5 ... 20	–
Threaded: M8, M12, M18, M30	Threaded: M8, M12, M18, M30	Threaded: M8, M12, M18, M30		XS●●4: Ø 4 Threaded: M5
Plastic	Nickel plated brass	Nickel plated brass		Stainless steel
●	●	●	●	●
–	–	–	–	–
●	–	–	–	–
–	●	●	●	●
●	●	●	●	●
–	–	–	–	–
–	–	–	–	–
●	●	●	●	●
–	●	●	●	●
–	●	●	●	–
●	–	–	–	–
Remote connectors available: M8, M12, M18, screw terminal, 7/8", DIN: please consult our Customer Care Centre				
IP 67 or IP 68 depending on model	IP 67	IP 65 or IP 67	IP 67 or IP 68 IP 69K depending on model	IP 67
Add the suffix TF to the end of the reference (2)				–
Add the suffix TT to the end of the reference (2)				–
XS4P	XS1●●BL● XS2●●BL●	XS1●●BH●	XS1N●●349	XS504●●●●, XS505●●●●
68	<a href="#">Catalogue Inductive proximity sensors - Basic Line</a>		70	74

## Applications

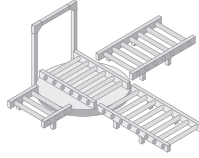

Conveying

Sensor type: flush and non-flush mountable

Adjustable range sensors

Developed in accordance with the needs expressed by our customers, these sensors provide a complete solution for specific application functions: rotation monitoring, selective detection, analogue control, etc.



<b>Sensing dist. Sn (mm)</b>	Flush mountable Non-flush mountable
<b>Form</b>	<b>Cylindrical</b>  <b>Block (W x H x D) dimensions in mm</b>
<b>Case material</b>	
<b>Supply</b>	  
<b>Function</b>	NO NC NO + NC NO/NC
<b>Connection</b>	Pre-cabled (L = 2 m) (2) M8 connector, 3-pin (--- 3-wire) M12 connector 1/2"-20UNF connector Remote connector Screw terminals
<b>Degree of protection</b>	
<b>Special temperatures</b>	- 40 °C, + 70 °C - 25 °C, + 85 °C
<b>Type reference</b>	
<b>Pages</b>	

	3...11 (1)	15	25	60
<b>5...18 (1)</b>	–	–	–	–
M12 x 54 M18 x 67 M30 x 71	–	–	–	–
–	26 x 26 x 13	40 x 40 x 15	80 x 80 x 26	
Case material	Nickel plated brass	PBT	PBT	PBT
Supply	•	•	•	•
–	–	–	–	–
–	•	•	•	•
•	•	•	•	•
•	•	•	•	•
–	–	–	–	–
–	–	–	–	–
–	•	•	•	•
–	•	•	•	•
–	–	–	–	–
Degree of protection	IP 67	IP 67 or IP 68, depending on model.		
Special temperatures	Add the suffix TF to the end of the reference (4)			
–	Add the suffix TT to the end of the reference (4)			
Type reference	<b>XS612B2</b> <b>XS618 B2</b> <b>XS630 B2</b>	<b>XS8E</b>	<b>XS8C</b>	<b>XS8D</b>
Pages	76	52		

(1) Depending on model.

(2) Also available in lengths of 5 and 10 m, depending on model.

(3) For M12 connector version

(4) Product availability depending on model: please consult our Customer Care Centre.

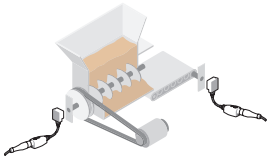

Detection of underspeed, shaft overload

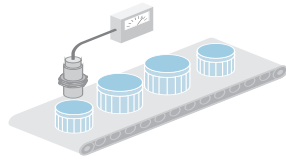

Position, displacement and deformation control/monitoring

Machine with stainless steel housing

Sensors for rotation monitoring

Sensors with analogue output  
0 ... 10 V or 4 ... 20 mA

Sensors for food/beverage and pharmaceutical applications

Cylindrical, stainless steel 316 L

Cylindrical, plastic



10	10...15 (1)	0.2...10 (1)	5...40 (1)	—	—	6,10 or 20 (1)	—	—
10	10...15 (1)	0.4...15 (1)	5...40 (1)	2...25	2...25	10, 20 or 40 (1)	7...22 (1)	7...22 (1)
M30 x 81	—	Threaded: M12, M18, M30	—	—	—	Threaded: M12, M18, M30	Plain: Ø 18 Threaded: M12, M18, M30	Threaded: M12, M18, M30
—	26 x 26 x 13 40 x 40 x 15	—	32 x 15 x 8 26 x 26 x 13 40 x 40 x 15 80 x 80 x 26	40 x 40 x 70	40 x 40 x 117	—	—	—
Metal	PBT	Metal or plastic	PBT	PBT	PBT	Stainless steel, 316 L	Stainless steel, 316 L	Plastic, PPS
•	•	•	•	•	•	•	•	•
—	—	—	—	—	—	—	—	—
•	•	—	—	—	—	—	•	•
—	—	—	—	—	—	•	•	•
•	•	—	—	—	—	—	—	—
—	—	—	—	—	—	—	—	—
—	—	—	—	—	—	—	—	—
•	—	•	•	—	—	—	•	•
—	—	—	—	—	—	—	—	—
—	—	—	•	•	—	•	•	•
—	—	—	—	—	—	—	•	•
—	•	—	•	—	—	—	—	—
—	—	—	—	—	•	—	—	—
IP 67	IP 67	IP 67	IP 67 or IP 68 (pre-cabled version)	IP 65, IP 67 IP 69K	IP 65, IP 67 IP 69K	IP 68, IP 69K	IP 68 (pre-cabled version), IP 69K conforming to DIN 40050 (3)	—

Add the suffix TF to the end of the reference (4)

Add the suffix TT to the end of the reference (4)

XSAV	XS9●11R	XS1M●●●AB1 XS4P●●AB1	XS9●●●A	XS9C2	XS9C4	XS9●●S●	XS2●●SA	XS2●●AA
79	81	83	87 and 89	90	90	92	94 and 96	98 and 100

### Applications

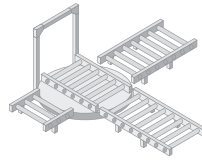

Conveying

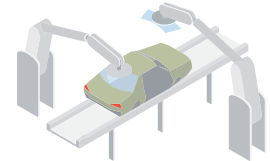
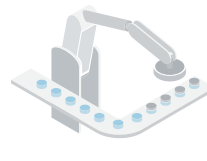

Robotics

Sensor type: flush and non-flush mountable

Sensors for conveying and material handling applications	Sensors for welding machine applications	
Cylindrical, stainless steel 303	80 x 80 x 40 format, increased range	Cylindrical, stainless steel 303

Developed in accordance with the needs expressed by our customers, these sensors provide a complete solution for specific application functions: rotation monitoring, selective detection, analogue control, etc.



<b>Sensing dist.</b>	Flush mountable
<b>Sn (mm)</b>	Non-flush mountable
<b>Form</b>	<b>Cylindrical</b>
	<b>Block (W x H x D) dimensions in mm</b>
<b>Case material</b>	
<b>Supply</b>	<ul style="list-style-type: none"> <li>⋮</li> <li>~</li> <li>~</li> </ul>
<b>Function</b>	<ul style="list-style-type: none"> <li>NO</li> <li>NC</li> <li>NO + NC</li> <li>NO/NC</li> </ul>
<b>Connection</b>	<ul style="list-style-type: none"> <li>Pre-cabled (L = 2 m) (2)</li> <li>M8 connector, 3-pin (⋮ 3-wire)</li> <li>M12 connector</li> <li>1/2"-20UNF connector</li> <li>Remote connector</li> <li>Screw terminals</li> </ul>
<b>Degree of protection</b>	
<b>Special temperatures</b>	<ul style="list-style-type: none"> <li>- 40 °C, + 70 °C</li> <li>- 25 °C, + 85 °C</li> <li>- 40 °C, + 85 °C (storage)</li> </ul>
<b>Type reference</b>	
<b>Pages</b>	

	<b>3, 6, 10 or 20 (1)</b>	<b>50</b>	<b>6 or 10 (1)</b>
<b>Sn (mm)</b>	<b>6, 10, 20 or 40 (1)</b>	<b>42</b>	<b>–</b>
<b>Threaded:</b>	M8, M12, M18, M30	–	Threaded: M12, M18
<b>Block (W x H x D) dimensions in mm</b>	–	80 x 80 x 40	–
<b>Case material</b>	Stainless steel 303	PBT	Stainless steel 303
<b>Supply</b>	•	•	•
	–	–	–
	–	–	–
<b>Function</b>	•	•	•
	–	–	–
	–	–	–
	–	–	–
	–	–	–
	–	–	–
	–	–	–
	–	–	–
<b>Degree of protection</b>	IP 67 and IP 69K	IP 67	IP 68 and IP 69K
<b>Special temperatures</b>	Add the suffix TF to the end of the reference (3)		
	Add the suffix TT to the end of the reference (3)		
	–		
<b>Type reference</b>	<b>XS9●●R●</b>	<b>XS7D</b>	<b>XS9●●RW</b>
<b>Pages</b>	102	104	106

(1) Depending on model.

(2) Also available in lengths of 5 and 10 m, depending on model.

(3) Product availability depending on model: please consult our Customer Care Centre

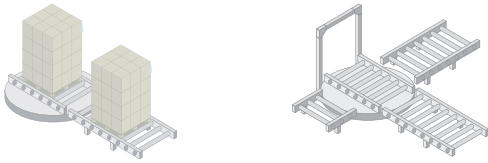

Assembly machines, conveyor systems, material handling

Factor 1 (Fe/Nfe) sensors for ferrous and non ferrous materials			Selective detection sensors for ferrous materials only or non ferrous materials only	Fail Safe			
Cylindrical	Cubic	Rectangular		Cylindrical	Cylindrical, increased range	Cubic	Rectangular
							
5, 10 or 15 (1)	20	20	5	2, 5 or 10 (1)	4, 8 or 15 (1)	20	20
–	–	–	–	–	–	40	40
Threaded: M18, M30	–	–	Threaded: M18	Threaded: M12, M18, M30	Threaded: M12, M18, M30	–	–
–	40 x 40 x 70	40 x 40 x 117	–	–	–	40 x 40 x 70	40 x 40 x 117
Metal	PBT	PBT	Metal	Nickel plated brass/PPS	Nickel plated brass	PBT	PBT
•	•	•	•	•	•	•	•
–	–	–	–	–	–	–	–
–	–	–	–	–	–	–	–
–	–	–	•	–	–	–	–
–	–	–	–	–	–	–	–
–	•	•	–	•	•	•	•
•	–	–	–	–	–	–	–
•	–	–	•	•	•	–	–
–	–	–	–	–	–	–	–
•	•	–	–	•	•	•	–
–	–	–	–	–	–	–	–
•	–	–	–	–	–	–	–
–	–	•	–	–	–	–	•
IP 68	IP 65, IP 67 and IP 69K		IP 68	IP 65, IP 67, and IP 69K for M12 IP 65 and IP 68 for pre-cabled		IP 65, IP 67, and IP 69K	
Add the suffix TT to the end of the reference (3)				•	•	•	•
Add the suffix TT to the end of the reference (3)				–	–	–	–
–	–	–	–	•	•	•	•
<b>XS1M●●●KP</b>	<b>XS9C2</b>	<b>XS9C4</b>	<b>XS1M18PA</b>	<b>XS5●●BSPD</b>	<b>XS1●●BSPD</b>	<b>XS8C2A●PD</b>	<b>XS8C4A●PD</b>
66	108	108	110	112	114	116	118

### Standards and certifications

#### Parameters related to the environment

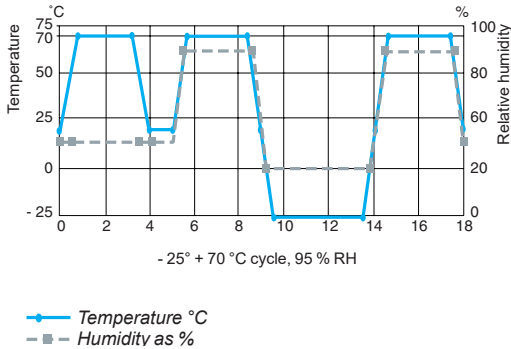

### Recommendations

The sensors detailed in this catalogue are designed for use in standard industrial applications relating to presence detection. These sensors do not incorporate the required redundant electrical circuit enabling their usage in safety applications. For safety applications, please consult our website: [www.telemecaniquesensors.com](http://www.telemecaniquesensors.com)

### Quality control

**Our inductive proximity sensors are subject to special precautions in order to guarantee their reliability in the most arduous industrial environments.**

- **Qualification**
  - The product characteristics stated in this catalogue are subject to a **qualification procedure** carried out in our laboratories.
  - In particular, the products are subjected to **climatic cycle** tests for 3000 hours whilst powered-up to verify their ability to maintain their characteristics over time.
- **Production**
  - The electrical characteristics and sensing distances at both ambient temperature and extreme temperatures are 100% checked.
  - Products are randomly selected during the course of production and subjected to **monitoring tests** relating to all their qualified characteristics.

#### Customer returns

If, in spite of all these precautions, defective products are returned to us, they are subject to **systematic analysis** and **corrective actions** are implemented to eliminate the risks of the fault recurring.

### Conformity to standards

**All Telemecanique Sensors brand inductive proximity sensors conform to and are tested in accordance with the recommendations of standard IEC 60947-5-2.**

### Mechanical shock resistance

The sensors are tested in accordance with standard IEC 60068-2-27, 50 gn, duration 11 ms.

### Vibration resistance

The sensors are tested in accordance with standard IEC 60068-2-6, amplitude  $\pm 2$  mm,  $f = 10 \dots 55$  Hz, 25 gn at 55 Hz.

### Resistance to the environment

- Please refer to the characteristics pages for the various sensors.
- **IP 67:** protection against the effects of immersion.
  - Test conforming to IEC 60529: sensor immersed for 30 minutes in 1 m of water. No deterioration in either operating or insulation characteristics is permitted.
- **IP 68:** protection against prolonged immersion.
  - Sensor immersed for 336 hours in 40 metres of water at 50 °C. No deterioration in either operating or insulation characteristics is permitted. Telemecanique Sensors with an IP 68 degree of protection are ideal for use in the most arduous conditions, such as machine tools, automatic car washers.
- **IP 69K:** protection against the effects of high pressure cleaning. Adherence to standard DIN 40050 which stipulates that the product must withstand a water jet at a pressure of 90 bar and temperature of +80 °C for 3 minutes.
  - No deterioration in either operating or insulation characteristics is permitted.

### Resistance to electromagnetic interference

- Electrostatic discharges
  - $\sim$  and  $\approx$  versions: 4 kV CD/8 kV AD immunity. **IEC 61000-4-2**
- Radiated electromagnetic fields (electromagnetic waves)
  - $\equiv$ ,  $\sim$  and  $\approx$  versions: 3 V/m or 10 V/m immunity. **IEC 61000-4-3**
- Fast transients (motor start/stop interference)
  - $\equiv$  version: > 1 kV immunity
  - $\sim$  and  $\approx$  versions: 2 kV immunity except  $\emptyset$  8 mm model. **IEC 61000-4-4**
- Conducted electromagnetic fields
  - $\equiv$ ,  $\sim$ , and  $\approx$  versions: > 3 kV immunity. **IEC 61000-4-6**
- Emission  $\equiv$ ,  $\sim$ , and  $\approx$ 
  - class B

### Resistance to chemicals in the environment

- Owing to the very wide range of chemicals encountered in industry, it is very difficult to give general guidelines common to all sensors.
- To ensure lasting efficient operation, it is essential that any chemicals coming into contact with the sensors will not affect their casing and, in doing so, prevent their reliable operation.
- Cylindrical and flat plastic case sensors offer excellent overall resistance to:
  - chemical products such as salts, aliphatic and aromatic oils, petroleum, acids and diluted bases. For alcohols, ketones and phenols, preliminary tests should be made relating to the nature and concentration of the liquid.
  - food and beverage industry products such as animal or vegetable based products (vegetable oils, animal fat, fruit juice, dairy proteins, etc.).

In all cases, the materials selected (see product characteristics) provide satisfactory compatibility in most industrial environments (for further information, please consult our Customer Care Centre).

### Insulation

### Class 2 devices

Electrical insulation conforming to standards IEC 61140 and NF C 20-030 relating to means of protection against electric shock.

## Principle of inductive detection

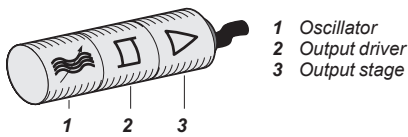

Composition of an inductive proximity sensor

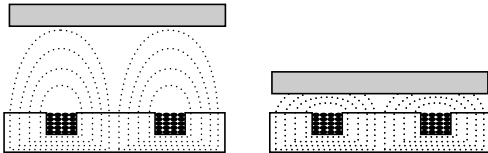

Detection of a metal object

## Operating principle

■ An inductive proximity sensor is solely for the detection of metal objects. It basically comprises an oscillator whose windings constitute the sensing face. An alternating magnetic field is generated in front of these windings.

■ When a metal object is placed within the magnetic field generated by the sensor, the resulting currents induced form an additional load and the oscillations cease. This causes the output driver to operate and, depending on the sensor type, a normally open (NO) or normally closed (NC) output signal is produced.

## Inductive proximity detection

- Inductive proximity sensors enable the detection, without physical contact, of metal objects.
- Their range of applications is very extensive and includes:
  - monitoring the position of machine parts (cams, end stops, etc.),
  - counting the presence of metal objects, etc.

## Advantages of inductive detection

- No physical contact with the object to be detected, thus avoiding wear and enabling detection of fragile objects, freshly painted objects, etc.
- High operating rates. Fast response.
- Excellent resistance to industrial environments (robust products, fully encapsulated in resin).
- Solid-state technology: no moving parts, therefore service life of sensor not related to number of operating cycles.

## Flush mountable using teach mode sensors

- The flush mountable sensors using teach mode are suitable for all metal environments (flush mountable or non-flush mountable) since they ensure a maximum sensing distance, even if there is a metal background. Precise detection of the position of the object can be obtained using the teach mode. For further information, see page 22.

## LED indicator

	NO output	NC output
No object present	LED Output state	LED Output state
Object present	LED Output state	LED Output state

## Output LED

All Telemecanique Sensors inductive proximity sensors incorporate an output state LED indicator.

The flush mountable sensors using teach mode are fitted with a green LED that indicates "Power on" and also assists the user during setting-up (teach mode).

## Mounting sensors on a metal support

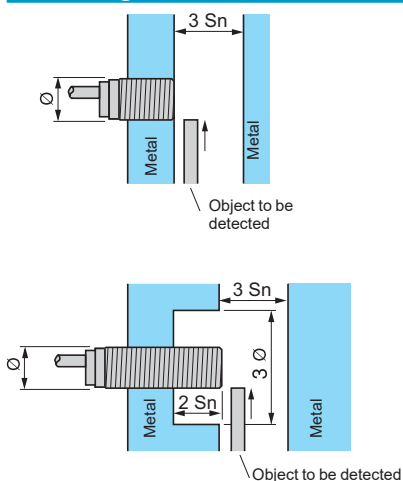

## Flush mountable in metal

- No side clearance required.
- All flush mountable sensors using teach mode also enable detection of an object against a metal background. For further information, see pages 22 and 23.

## Sensors not suitable for flush mounting in metal

- Side clearance required.
- Sensing distance greater than that for a standard flush mountable model.
- Flush mountable sensors using teach mode eliminate the need for side clearance. For further information, see pages 22 and 23.

### Mounting sensors on a metal support

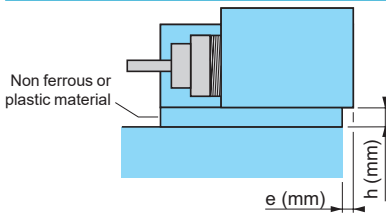

### Mounting distance between sensors

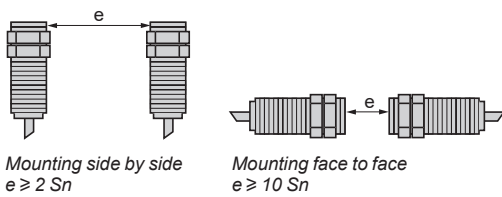

### Mounting using fixing clamp

- Standard flush mountable models:  $e = 0, h = 0$
- Standard non-flush mountable models
- $\text{Ø } 6.5 / 8 / 12 \text{ mm: } e = 0, h = 0$
- $\text{Ø } 18 \text{ mm: if } h = 0, e \geq 5; e = 0, h \geq 3.$
- $\text{Ø } 30 \text{ mm: if } h = 0, e \geq 8; e = 0, h \geq 4.$
- Flush mountable sensors using teach mode:  $e = 0, h = 0$

### Standard sensors

If 2 standard sensors are mounted too close to each other they are likely to lock in the "detection state" due to interference between their respective oscillating frequencies. To avoid this condition, the minimum mounting distances stated for the sensors should be adhered to or, alternatively, sensors with staggered oscillating frequencies should be used.

### Staggered frequency sensors

For applications where the minimum recommended mounting distances for standard sensors cannot be achieved, it is possible to overcome this restraint by using staggered frequency sensors. Please consult our Customer Care Centre. In this case, a staggered frequency sensor is mounted adjacent to or opposite each standard sensor.

### Tightening torque for cylindrical type sensors

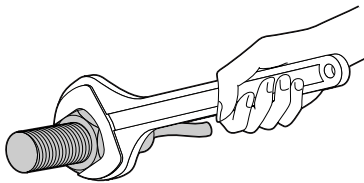

### Maximum tightening torque for the various sensor case materials

Diameter of sensor	Metal		Stainless steel		Plastic	
	N.m	lb-in	N.m	lb-in	N.m	lb-in
Ø 5	1.6	14.16	–	–	–	–
Ø 8	5	44.25	9	79.65	1	8.85
Ø 12	6	53.10	30	265.52	2	17.70
Ø 18	15	132.76	50	442.54	5	44.25
Ø 30	40	354.03	100	885.07	20	177.01

## Sensing distance

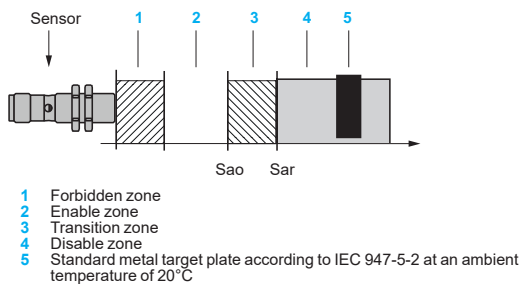
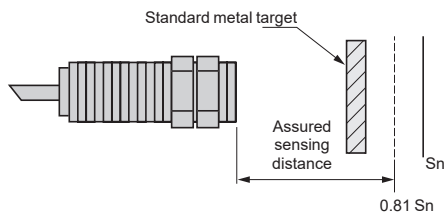
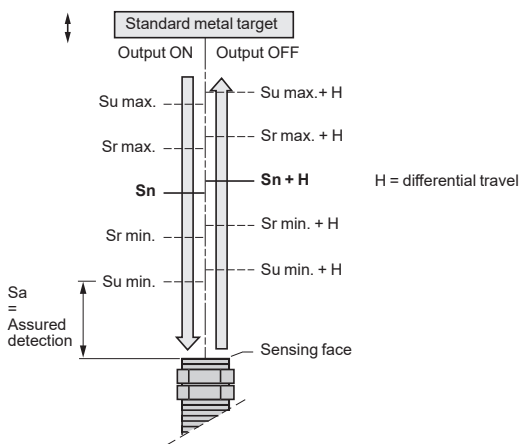

## Terminology

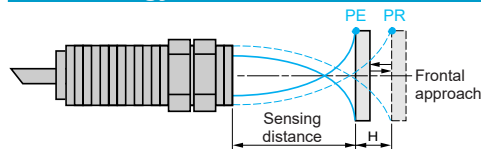

PE = pick-up point, the object is detected  
PR = drop-out point, the object is no longer detected

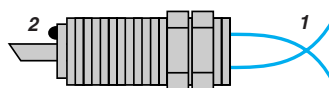
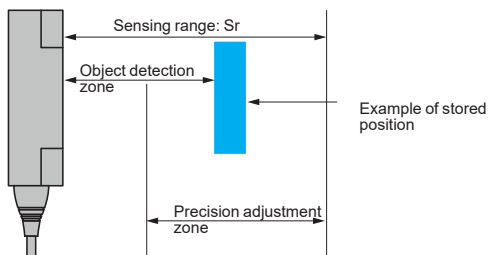

1 Detection threshold curves  
2 "Object detected" LED

## Definitions

In order to ensure that customers can make reliable product comparisons and selection, the standard IEC 60947-5-2 defines various sensing distances, such as:

- **Nominal sensing distance (Sn)**  
The rated operating distance for which the sensor is designed. It does not take into account any variations (manufacturing tolerances, temperature, voltage).
- **Effective sensing distance (Sr)**  
The effective sensing distance is measured at the rated voltage (Un) and the rated ambient temperature (Tn). It must be between 90% and 110% of the nominal sensing distance (Sn):  $0.9 Sn \leq Sr \leq 1.1 Sn$ .
- **Usable sensing distance (Su)**  
The usable sensing distance is measured at the limits of the permissible variations in the ambient temperature (Ta) and the supply voltage (Ub). It must be between 90% and 110% of the effective sensing distance:  $0.9 Sr \leq Su \leq 1.1 Sr$ .
- **Assured operating distance (Sa)**  
This is the operating zone of the sensor. The assured sensing distance is between 0 and 81% of the nominal sensing distance (Sn):  $0 \leq Sa \leq 0.9 \times 0.9 \times Sn$ .

## Standard metal target

The standard IEC 60947-5-2 defines the standard metal target as a square mild steel (Fe 360) plate, 1 mm thick. The side dimension of the plate is either equal to the diameter of the circle engraved on the sensing face of the sensor or 3 times the nominal sensing distance (Sn).

## Fail Safe

- **Forbidden zone (1)**  
This zone ensures that it will not be possible to defeat the solution with simple elements or standard tools (ie: glue a coin on the front face). It is a minimum distance maintaining safe condition in all aspects. In this zone, both sensor outputs are opened.
- **Assured operating distance (Sao)**  
When the target approaches the sensor, the contacts will change state no later than Sao max and remain in the same state as the target continues to approach the switch. At distances beyond the Sao min, the contacts enter in the forbidden zone, not maintaining a closed condition in all aspects.
- **Assured release distance (Sar)**  
Minimum distance from the sensor that the target must move to assure the reset of the sensor.
- **Standard metal target plate (5)**  
According to IEC 947-5-2 at an ambient temperature of 20°C.

## Differential travel

The differential travel (H), or hysteresis, is the distance between the operating point, as the standard metal target moves towards the sensor, and the release point, as it moves away. This hysteresis is essential for the stable operation of the sensor.

## Repeat accuracy

The repeat accuracy (R) is the repeatability of the sensing distance between successive operations. Readings are taken over a period of time whilst the sensor is subjected to voltage and temperature variations: 8 hours, 10 to 30 °C,  $Un \pm 5\%$ . It is expressed as a percentage of the effective sensing distance Sr. For all XS sensors, the repeat accuracy is 3%.

## Detection zone and precision adjustment zone

- Flush mountable sensors using teach mode, due to adjustment of sensitivity whilst teaching, enable the position of an object to be detected as it approaches from the front or side. The teach mode can be used when the object is located in the zone known as the "precision adjustment zone". When the object approaches from the front, the detection zone of the object ranges from the stored position down to zero.

## Operating zone

- The operating zone relates to the area in front of the sensing face in which the detection of a metal object is certain. The values stated in the characteristics relating to the various types of sensor are for steel objects of a size equal to the sensing face of the sensor. For objects of a different nature (smaller than the sensing face of the sensor, other metals, etc.), it is necessary to apply a correction coefficient.

### Correction coefficients to apply to the assured operating distance

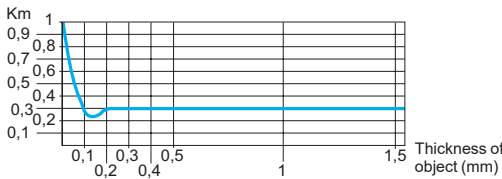
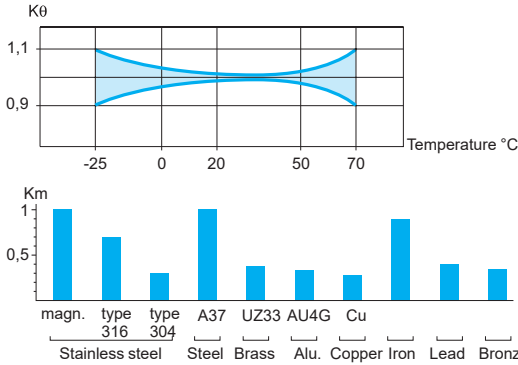

Typical curve for a copper object used with a Ø 18 mm cylindrical sensor

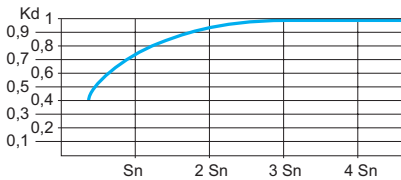

Typical curve for a steel object used with a cylindrical sensor

### Assured operating distance of a sensor

In practice, most objects to be detected are generally made of steel and are of a size equal to, or greater, than the sensing face of the sensor.

For the calculation of the assured operating distance for different operating conditions, one must take into account the correction coefficients that influence it.

The curves indicated are purely representative of typical curves. They are only given as a guide to the approximate usable sensing distance of a proximity sensor for a given application.

### Influence of ambient temperature

Apply a correction coefficient  $K_{\theta}$ , determined from the curve shown opposite.

### Material of object to be detected

Apply a correction coefficient  $K_m$ , determined from the diagram shown opposite.

The fixed sensing distance models for ferrous/non ferrous (Fe/NFe) materials enable the detection of different objects at a fixed distance, irrespective of the type of material.

Special case of a very thin object made of a non ferrous material.

### Size of object to be detected

Apply a correction coefficient  $K_d$ , determined from the curve shown opposite. When calculating the sensing distance for the selection of a sensor, make the assumption that  $K_d = 1$ .

### Variation of supply voltage

In all cases, apply the correction coefficient  $K_t = 0.9$ .

### Calculation examples

#### Correction of the sensing distance of a sensor

Sensor with nominal sensing distance  $S_n = 15$  mm.  
 Ambient temperature variation 0 to + 20 °C.  
 Object material and size: steel, 30 x 30 x 1 mm thick.  
 The assured sensing distance  $S_a$  is determined using the formula:  
 $S_a = S_n \times K_{\theta} \times K_m \times K_d \times K_t = 15 \times 0.98 \times 1 \times 0.95 \times 0.9$   
 i.e.  $S_a = 12.5$  mm.

#### Selecting a sensor for a given application

Application characteristics:  
 - object material and size: iron ( $K_m = 0.9$ ), 30 x 30 mm,  
 - temperature: 0 to 20 °C ( $K_{\theta} = 0.98$ ),  
 - object detection distance: 3 mm ± 1.5 mm, i.e.  $S_a \text{ max.} = 4.5$  mm,  
 - assume  $K_d = 1$ .

A sensor must be selected for which  $S_n \geq \frac{S_a}{K_{\theta} \times K_m \times K_d \times K_t} = \frac{4.5}{0.98 \times 0.9 \times 1 \times 0.9}$   
 i.e.  $S_n \geq 5.7$  mm

### Specific aspects of electronic sensors

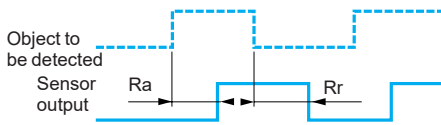
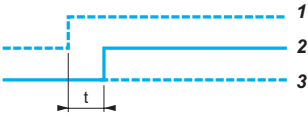
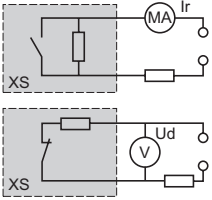

### Supply

### Terminology

- Residual current (Ir)
  - The residual current (Ir) corresponds to the current flowing through the sensor when in the "open" state.
  - Characteristic of 2-wire type proximity sensors.
- Voltage drop (Ud)
  - The voltage drop (Ud) corresponds to the voltage drop at the sensor's terminals when in the "closed" state (value measured at nominal current rating of sensor).
- First-up delay
  - The first-up delay corresponds to the time (t) between the connection of the power supply to the sensor and its fully operational state.
- 1 Supply voltage U on
- 2 Sensor operational at state 1
- 3 Sensor at state 0
- Response time
  - Response time (Ra): the time delay between the object to be detected entering the sensor's operating zone and the subsequent change of output state. This parameter limits the speed and size of the object.
  - Recovery time (Rr): the time delay between an object to be detected leaving the sensor's operating zone and the subsequent change of output state. This parameter limits the interval between successive objects.

### Sensors for AC circuits (~ and ~ models)

Check that the voltage limits of the sensor are compatible with the nominal voltage of the AC supply used.

### Sensors for DC circuits

- DC source: check that the voltage limits of the sensor and the acceptable level of ripple are compatible with the supply used.
- AC source (comprising transformer, rectifier, smoothing capacitor): the supply voltage must be within the operating limits specified for the sensor.

Where the voltage is derived from a single-phase AC supply, the voltage must be rectified and smoothed to ensure that:

- the peak voltage of the DC supply is lower than the maximum voltage rating of the sensor.
- the minimum voltage of the supply is greater than the minimum voltage rating of the sensor,

given that :

$$\Delta V = (I \times t) / C$$

$\Delta V$  = max. ripple: 10 % (V),

I = anticipated load current (mA),

t = period of 1 cycle (10 ms full-wave rectified for a 50 Hz supply frequency),

C = capacitance ( $\mu$ F).

As a general rule, use a transformer with a lower secondary voltage (Ue) than the required DC voltage (U).

#### Example:

~ 18 V to obtain  $\text{---}$  24 V,

~ 36 V to obtain  $\text{---}$  48 V.

### Outputs

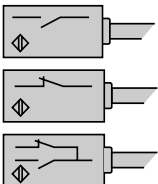

### Output signal (contact logic)

- Normally open (NO)
  - Corresponds to a sensor whose output changes to the closed state when an object is present in the operating zone.
- Normally closed (NC)
  - Corresponds to a sensor whose output changes to the open state when an object is present in the operating zone.
- Complementary outputs (NO + NC)
  - Corresponds to a sensor with a normally closed output and a normally open output.

### Outputs (continued)

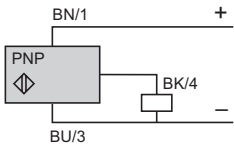
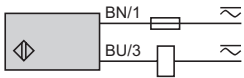
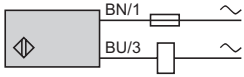
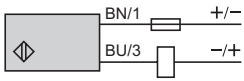

NO output

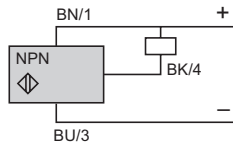

NO output

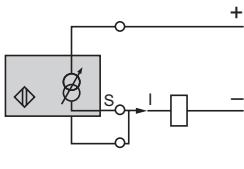
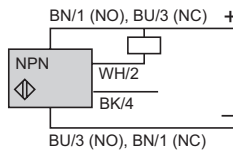
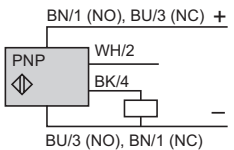
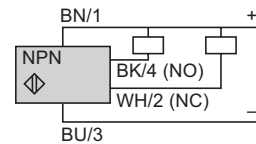
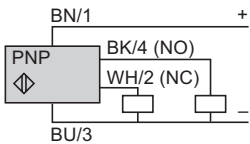

2-wire connection

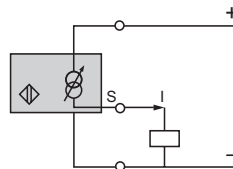

3-wire connection

### 2-wire type, non polarised NO or NC output

■ **Specific aspects**

These sensors are wired in series with the load to be switched.

As a consequence, they are subject to:

- a residual current in the open state (current flowing through the sensor in the “open” state),
- A voltage drop in the closed state (voltage drop across the sensor’s terminals in the “closed” state).

■ **Advantages**

- Only 2 leads to be wired: these sensors can be wired in series in the same way as mechanical limit switches,
- They can be connected to either positive (PNP) or negative (NPN) logic PLC inputs,
- No risk of incorrect connections.

■ **Operating precautions**

- Check the possible effects of residual current and voltage drop on the actuator or input connected,
- For sensors that do not have overload and short-circuit protection (AC or AC/DC symbol), it is essential to connect a 0.4 A “quick-blow” fuse in series with the load.

### 3-wire type, NO or NC output, PNP or NPN

■ **Specific aspects**

These sensors comprise 2 wires for the DC supply and a 3rd wire for the output signal,

- PNP type: switching the positive side to the load,
- NPN type: switching the negative side to the load.

■ **Advantages**

- Protection against supply reverse polarity,
- Protection against overload and short-circuit,
- No residual current, low voltage drop.

### 4-wire type, complementary NO and NC outputs, PNP or NPN

■ **Advantages**

- Protection against supply reverse polarity (+/-).
- Protection against overload and short-circuit.

### 4-wire type, multifunction, programmable NO or NC output, PNP or NPN

■ **Advantages**

- Protection against supply reverse polarity (+/-).
- Protection against overload and short-circuit.

### Specific output signals, analogue type

■ These sensors convert the approach of a metal object towards the sensing face into an output current variation which is proportional to the distance between the object and the sensing face.

■ Two models available:

- 0...10 V (0...10 mA) output for 3-wire connection,
- 4-20 mA output for 2-wire connection.

### Features of the various models

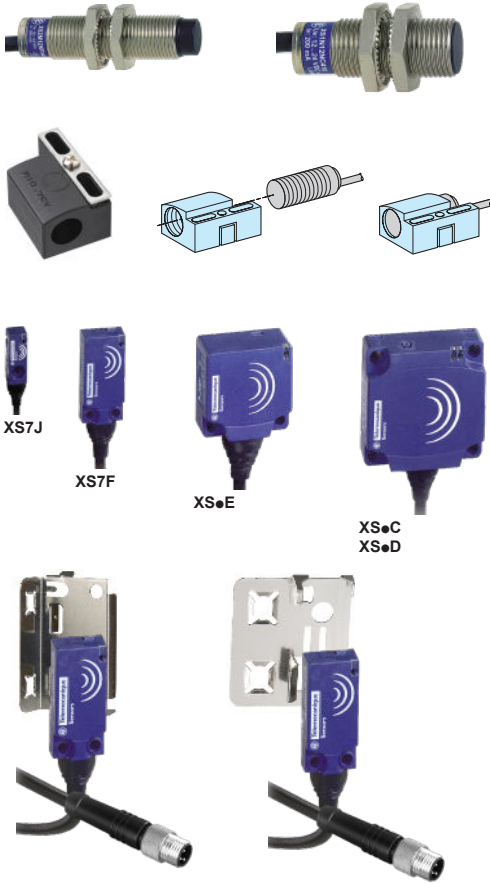

### Types of case

- **Cylindrical case**
  - Fast installation and setting-up.
  - Short case and long case, 2-wire and 3-wire versions available.
  - Pre-cabled (moulded cable) and various integral connector (M8, M12, 7/8", M18) and remote connector (on flying lead) versions available.
  - Small size facilitates mounting in locations with restricted access.
  - **Interchangeability**, provided by indexed **fixing clamp**: when assembled, becomes similar to a block type sensor.

- **Flat case**
  - Reduced size (sensor volume divided by 8).
  - Fast installation by mounting on clip-on brackets.
  - Precision detection with the flush mountable sensors using teach mode (see page 22).

### Electrical connection



### Connection methods

- 1 Pre-cabled:** factory fitted moulded cable, good protection against splashing liquids (IP 68). Example: machine tool.
- 2 Connector:** easy installation and maintenance (IP 67).
- 3 Remote connector:** easy installation and maintenance (IP 68 at sensor level and IP 67 at remote connector level).

### Wiring advice

- **Length of cable**
  - No limitation up to 200 m or up to a line capacitance of < 100 nF (characteristics of sensor remain unaffected).
  - In this case, it is important to take into account the voltage drop on the line.
- **Separation of control and power circuit wiring**
  - The sensors are immune to electrical interference encountered in normal industrial conditions.
  - Where extreme conditions of electrical "noise" could occur (large motors, spot welders, etc.), it is advisable to protect against transients in the normal way:
    - suppress interference at source,
    - separate power and control wiring from each other,
    - smooth the supply,
    - limit the length of cable.
- **Connect the sensor with supply switched off.**

### Setting-up precautions

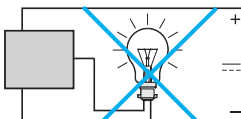
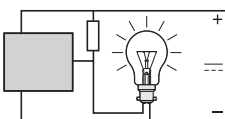
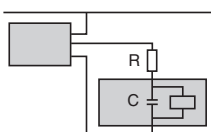
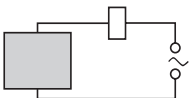
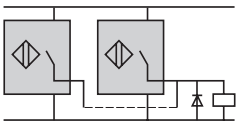
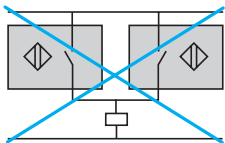
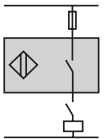
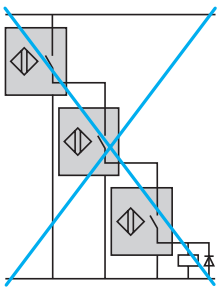
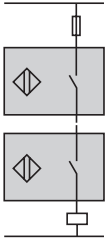

### Connection in series

#### 2-wire type sensors

- The following points should be taken into account:
  - Series wiring is only possible using sensors with wide voltage limits. Based on the assumption that each sensor has the same residual current value, each sensor, in the open state, will share the supply voltage, i.e.

$$U_{\text{sensor}} = \frac{U_{\text{supply}}}{n_{\text{sensors}}}$$

- U sensor and U supply must remain within the sensor's voltage limits.
  - If only one sensor in the circuit is in the open state, it will be supplied at a voltage almost equal to the supply voltage.
  - When in the closed state, a small voltage drop is present across each sensor. The resultant loss of voltage at the load will be the sum of the individual voltage drops and therefore, the load voltage should be selected accordingly.

#### 3-wire type sensors

This connection method is not recommended.

- Correct operation of the sensors cannot be assured and, if this method is used, tests should be made before installation.
  - The following points should be taken into account:
    - Sensor 1 carries the load current in addition to the no-load current consumption values of the other sensors connected in series. For certain models, this connection method is not possible unless a current limiting resistor is used.
    - When in the closed state, a small voltage drop is present across each sensor. The load should therefore be selected accordingly.
    - As sensor 1 closes, sensor 2 does not operate until a certain time (t) has elapsed (corresponding to the first-up delay) and likewise for the following sensors in the sequence.
    - The use of "flywheel" diodes is recommended when an inductive load is being switched.

### Sensors and devices in series with an external mechanical contact

#### 2 and 3-wire type sensors

- The following points should be taken into account:
  - When the mechanical contact is open, the sensor is not supplied.
  - When the contact closes, the sensor does not operate until a certain time (t) has elapsed (corresponding to the first-up delay).

### Connection in parallel

#### 2-wire type sensors

This connection method is not recommended.

- Should one of the sensors be in the closed state, the sensor in parallel will be "shorted-out" and no longer supplied.
  - As the first sensor passes into the open state, the second sensor will become energised and will be subject to its first-up delay.
- This configuration is only permissible where the sensors will be working alternately.
- This method of connection can lead to irreversible damage of the units.

#### 3-wire type sensors

- No specific restrictions. The use of "flywheel" diodes is recommended when an inductive load (relay) is being switched.

### AC supply

■ 2-wire type sensors cannot be connected directly to an AC supply.

- This would result in immediate destruction of the sensor and considerable danger to the user.
- An appropriate load (refer to the instruction sheet supplied with the sensor) must always be connected in series with the sensor.

### Capacitive load (C > 0.1 μF)

- On power-up, it is necessary to limit (by resistor) the charging current of the capacitive load C.
- The voltage drop in the sensor can also be taken into account by subtracting it from the supply voltage for the calculation of R.

$$R = \frac{U_{\text{supply}}}{I_{\text{max. (sensor)}}$$

### Load comprising an incandescent lamp

- If the load comprises an incandescent lamp, the cold state resistance can be 10 times lower than the hot state resistance. This can cause very high current levels on switching. Fit a pre-heat resistor in parallel with the sensor.

$$R = \frac{U^2}{P} \times 10, U = \text{supply voltage and } P = \text{lamp power}$$

### Fast trouble shooting guide

Problem	Possible causes	Remedy
The sensor's output will not change state when a metal object enters the detection zone	On a flush mountable sensor using teach mode: setting-up or programming error.	<ul style="list-style-type: none"> <li>■ After a RESET, follow the environment teach mode procedure. Refer to instruction sheet supplied with sensor.</li> </ul>
	Output stage faulty or complete failure of the sensor or the short-circuit protection has tripped.	<ul style="list-style-type: none"> <li>■ Check that the sensor is compatible with the supply being used.</li> <li>■ Check the load current characteristics:                             <ul style="list-style-type: none"> <li>□ if load current <math>I \geq</math> maximum switching capacity, an auxiliary relay, of the CAD N type for example, should be interposed between the sensor and the load,</li> <li>□ if <math>I \leq</math> maximum switching capacity, check for wiring faults (short-circuit).</li> </ul> </li> <li>■ In all cases, a 0.4 A "quick-blow" fuse should be fitted in series with the sensor.</li> </ul>
	Wiring error	<ul style="list-style-type: none"> <li>■ Check that the wiring conforms to the wiring shown on the sensor label or instruction sheet.</li> </ul>
	Supply fault	<ul style="list-style-type: none"> <li>■ Check that the sensor is compatible with the supply (<math>\sim</math> or <math>\text{---}</math>).</li> <li>■ Check that the supply voltage is within the voltage limits of the sensor. Remember that with a rectified, smoothed supply, <math>U_{\text{peak}} = U_{\text{nominal}} \times \sqrt{2}</math> with a ripple voltage <math>\leq 10\%</math>.</li> </ul>
False or erratic operation, with or without the presence of a metal object in the detection zone	On flush mountable sensor using teach mode: setting-up or programming error.	<ul style="list-style-type: none"> <li>■ After a RESET, follow the environment teach mode procedure. Refer to instruction sheet supplied with sensor.</li> </ul>
	Influence of background or metal environment	<ul style="list-style-type: none"> <li>■ Refer to the instruction sheet supplied with the sensor. For sensors with adjustable sensitivity, reduce the sensing distance.</li> </ul>
	Sensing distance poorly defined for the object to be detected	<ul style="list-style-type: none"> <li>■ Apply the correction coefficients.</li> <li>■ Realign the system or run the teach mode again.</li> </ul>
	Influence of transient interference on the supply lines	<ul style="list-style-type: none"> <li>■ Ensure that any DC supplies, when derived from rectified AC, are correctly smoothed (<math>C &gt; 400 \mu\text{F}</math>).</li> <li>■ Separate AC power cables from low-level DC cables (24 V low level).</li> <li>■ Where very long distances are involved, use suitable cable: screened and twisted pairs of the correct cross-sectional area.</li> </ul>
	Equipment prone to emitting electromagnetic interference	<ul style="list-style-type: none"> <li>■ Position the sensors as far away as possible from any sources of interference.</li> </ul>
	Response time of the sensor too slow for the particular object being detected	<ul style="list-style-type: none"> <li>■ Check the suitability of the sensor for the position or size of the object to be detected.</li> <li>■ If necessary, select a sensor with a higher switching frequency.</li> </ul>
	Influence of high temperature	<ul style="list-style-type: none"> <li>■ Eliminate sources of radiated heat or protect the sensor casing with a heat shield.</li> <li>■ Realign, having adjusted the temperature around the fixing support.</li> </ul>
No detection following a period of service	Vibration, shock	<ul style="list-style-type: none"> <li>■ Realign the system.</li> <li>■ Replace the support or protect the sensor.</li> </ul>

# Inductive proximity sensors

## XS range

### Flush mountability using teach mode: simplicity through innovation

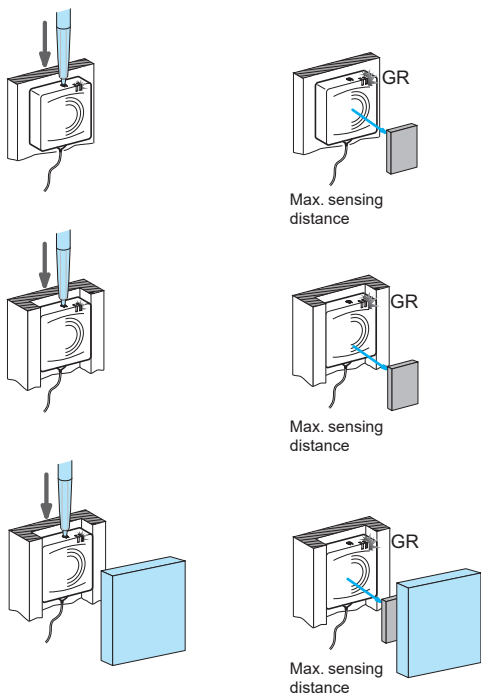

#### Operating principle

In proposing flush mountable sensors using teach mode, Telemecanique Sensors offers simplicity through innovation.

■ A single product enables flush mounting using teach mode and meets all the requirements for inductive detection of metal objects. By simply pressing the "Teach mode" button, the sensor automatically acquires optimum configuration for all detection, flush mountability and environment requirements.

■ Other advantages of flush mountable sensors using teach mode

- Increased performance:
  - sensing distance guaranteed and optimised irrespective of the mounting method, object, environment or background,
  - suitable for all metal environments.
- Simplified use provided by:
  - the flush mountability using teach mode technology, associated with the availability of the flattest and most compact sensors on the market, ensures full integration in the machine and limits the risks of mechanical damage,
  - mechanical adjustments no longer necessary due to teach mode.
- Lower costs due to:
  - the elimination of adjustment times and complex supports
  - the elimination of flush mountable and non-flush mountable versions, which halves the number of references,
  - much easier and much quicker product selection.

#### Precision position detection

All flush mountable inductive proximity sensors using teach mode benefit from ultra precise adjustment, which is very quick irrespective of the metal environment.

■ Precision side approach detection makes it possible to accurately define the distance at which the object will be detected as it passes the sensor.

On the flush mountable sensors using teach mode, the desired detection position can be stored in memory by simply pressing the teach button.

■ Precision frontal approach detection makes it possible to accurately define the distance at which the object will be detected as it approaches the sensor.

On the flush mountable sensors using teach mode, the desired detection position can be stored in memory by simply pressing the teach button.

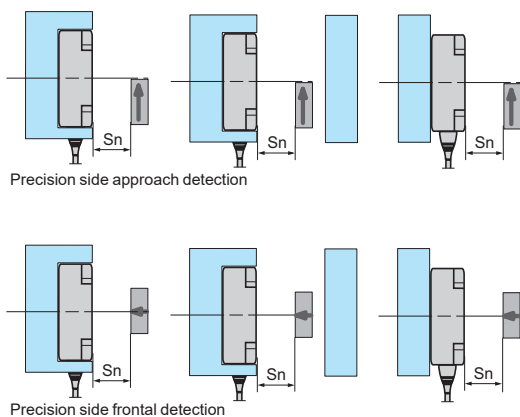

#### Mounting accessories

Telemecanique Sensors offers a complete, inexpensive range of mounting accessories (clamps, plates, brackets, etc.) that provide solutions for all installation problems.

- Fixing kits for quick installation or replacement of sensors
- No adjustment required. Simple clipping-in enables the sensor to be fixed in position and ready for operation.

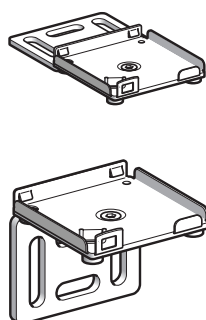

# Inductive proximity sensors

XS range

Flush mountability using teach mode:  
simplicity through innovation



## Cylindrical type

<b>Dimensions (mm)</b>		12	18	30
<b>Sensing distance (mm)</b>	Flush mounted use	0...3.4	0...6	0...11
	Non-flush mounted use	0...5	0...9	0...18
<b>Sensor type</b>		<b>XS612B2</b>	<b>XS618B2</b>	<b>XS630B2</b>
<b>Page</b>		76		



## Block type

<b>Dimensions (mm)</b>		26 x 26 x 13	40 x 40 x 15	80 x 80 x 26
<b>Sensing distance (mm)</b>	Flush mounted use	0...10	0...15	0...40
	Non-flush mounted use	0...15	0...25	0...60
<b>Sensor type</b>		<b>XS8E1A1</b>	<b>XS8C1A1</b>	<b>XS8D1A1</b>
<b>Page</b>		52		

# Inductive proximity sensors

XS range, general purpose

Cylindrical, standard range, flush mountable

Three-wire DC, solid-state output

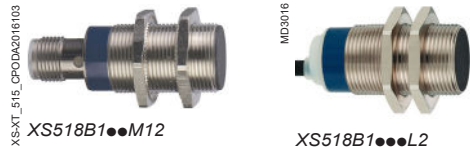

## Sensors, 3-wire 12...24 V, short case model

Sensing distance (Sn) mm	Function	Output	Connection	Reference	Weight (kg)
<b>Ø 6.5, plain</b>					
1.5	NO	PNP	Pre-cabled (L = 2 m) (1)	<b>XS506B1PAL2</b>	0.035
			M8 connector	<b>XS506B1PAM8</b>	0.025
			M12 connector	<b>XS506B1PAM12</b>	0.025
	NPN	PNP	Pre-cabled (L = 2 m) (1)	<b>XS506B1NAL2</b>	0.035
			M8 connector	<b>XS506B1NAM8</b>	0.025
			M12 connector	<b>XS506B1NAM12</b>	0.025
NC	PNP	Pre-cabled (L = 2 m) (1)	<b>XS506B1PBL2</b>	0.035	
		M8 connector	<b>XS506B1PBM8</b>	0.025	
		M12 connector	<b>XS506B1PBM12</b>	0.025	

## Ø 8, threaded M8 x 1

1.5	NO	PNP	Pre-cabled (L = 2 m) (1)	<b>XS508B1PAL2</b>	0.035
			M8 connector	<b>XS508B1PAM8</b>	0.025
			M12 connector	<b>XS508B1PAM12</b>	0.025
	NPN	PNP	Pre-cabled (L = 2 m) (1)	<b>XS508B1NAL2</b>	0.035
			M8 connector	<b>XS508B1NAM8</b>	0.025
			M12 connector	<b>XS508B1NAM12</b>	0.025
NC	PNP	Pre-cabled (L = 2 m) (1)	<b>XS508B1PBL2</b>	0.035	
		M8 connector	<b>XS508B1PBM8</b>	0.025	
		M12 connector	<b>XS508B1PBM12</b>	0.025	

## Ø 12, threaded M12 x 1

2	NO	PNP	Pre-cabled (L = 2 m) (1)	<b>XS512B1PAL2</b>	0.075
			M12 connector	<b>XS512B1PAM12</b>	0.035
			M12 connector	<b>XS512B1NAM12</b>	0.035
	NPN	PNP	Pre-cabled (L = 2 m) (1)	<b>XS512B1NAL2</b>	0.075
			M12 connector	<b>XS512B1NAM12</b>	0.035
			M12 connector	<b>XS512B1NAM12</b>	0.035
NC	PNP	Pre-cabled (L = 2 m) (1)	<b>XS512B1PBL2</b>	0.075	
		M12 connector	<b>XS512B1PBM12</b>	0.035	
		M12 connector	<b>XS512B1PBM12</b>	0.035	

## Ø 18, threaded M18 x 1

5	NO	PNP	Pre-cabled (L = 2 m) (1)	<b>XS518B1PAL2</b>	0.120
			M12 connector	<b>XS518B1PAM12</b>	0.060
			M12 connector	<b>XS518B1NAM12</b>	0.060
	NPN	PNP	Pre-cabled (L = 2 m) (1)	<b>XS518B1NAL2</b>	0.120
			M12 connector	<b>XS518B1NAM12</b>	0.060
			M12 connector	<b>XS518B1NAM12</b>	0.060
NC	PNP	Pre-cabled (L = 2 m) (1)	<b>XS518B1PBL2</b>	0.120	
		M12 connector	<b>XS518B1PBM12</b>	0.060	
		M12 connector	<b>XS518B1PBM12</b>	0.060	

## Ø 30, threaded M30 x 1.5

10	NO	PNP	Pre-cabled (L = 2 m) (1)	<b>XS530B1PAL2</b>	0.205
			M12 connector	<b>XS530B1PAM12</b>	0.145
			M12 connector	<b>XS530B1NAM12</b>	0.145
	NPN	PNP	Pre-cabled (L = 2 m) (1)	<b>XS530B1NAL2</b>	0.205
			M12 connector	<b>XS530B1NAM12</b>	0.145
			M12 connector	<b>XS530B1NAM12</b>	0.145
NC	PNP	Pre-cabled (L = 2 m) (1)	<b>XS530B1PBL2</b>	0.205	
		M12 connector	<b>XS530B1PBM12</b>	0.145	
		M12 connector	<b>XS530B1PBM12</b>	0.145	

## Accessories (2)

Description	For use with sensors (mm)	Reference	Weight (kg)
Fixing clamps	Ø 6.5 (plain)	<b>XSZB165</b>	0.005
	Ø 8	<b>XSZB108</b>	0.006
	Ø 12	<b>XSZB112</b>	0.006
	Ø 18	<b>XSZB118</b>	0.010
	Ø 30	<b>XSZB130</b>	0.020

(1) For a 5 m cable replace L2 by L5; for a 10 m cable replace L2 by L10. Please consult our Customer Care Center for availability.

Example: XS508B1PAL2 becomes XS508B1PAL5 with a 5 m cable.

(2) For more information, see page 120.

# Inductive proximity sensors

XS range, general purpose

Cylindrical, standard range, flush mountable

Three-wire DC, solid-state output



XS508B1DBL2  
XS5●●BL●●L2



103185  
XS508B1M12  
XS5●●BL●●M12



103180  
XS530BL●●L2



XS\_515\_CPF\_JR18004  
XSZB1●●

## Sensors, 3-wire 12...24 V, long case model

Sensing distance (Sn) mm	Function	Output	Connection	Reference	Weight (kg)
<b>Ø 8, threaded M8 x 1</b>					
1.5	NO	PNP	Pre-cabled (L = 2 m) (1)	<b>XS508BLPAL2</b>	0.035
			M12 connector	<b>XS508BLPAM12</b>	0.025
	NC	PNP	M12 connector	<b>XS508BLPBM12</b>	0.025
			NPN	M12 connector	<b>XS508BLNBM12</b>

## Sensors, 3-wire 12...48 V, long case model

Sensing distance (Sn) mm	Function	Output	Connection	Reference	Weight (kg)
<b>Ø 12, threaded M12 x 1</b>					
2	NO	PNP	Pre-cabled (L = 2 m) (1)	<b>XS512BLPAL2</b>	0.075
			M12 connector	<b>XS512BLPAM12</b>	0.035
	NC	PNP	Pre-cabled (L = 2 m) (1)	<b>XS512BLPBL2</b>	0.075
<b>Ø 18, threaded M18 x 1</b>					
5	NO	PNP	Pre-cabled (L = 2 m) (1)	<b>XS518BLPAL2</b>	0.120
			M12 connector	<b>XS518BLPAM12</b>	0.060
		NPN	Pre-cabled (L = 2 m) (1)	<b>XS518BLNAL2</b>	0.120
	NC	PNP	Pre-cabled (L = 2 m) (1)	<b>XS518BLPBL2</b>	0.120
			M12 connector	<b>XS518BLPBM12</b>	0.060
<b>Ø 30, threaded M30 x 1.5</b>					
10	NO	PNP	Pre-cabled (L = 2 m) (1)	<b>XS530BLPAL2</b>	0.205
			M12 connector	<b>XS530BLPAM12</b>	0.145
	NC	PNP	Pre-cabled (L = 2 m) (1)	<b>XS530BLPBL2</b>	0.205

## Accessories (2)

Description	For use with sensors (mm)	Reference	Weight (kg)
Fixing clamps	Ø 6.5 (plain)	<b>XSZB165</b>	0.005
	Ø 8	<b>XSZB108</b>	0.006
	Ø 12	<b>XSZB112</b>	0.006
	Ø 18	<b>XSZB118</b>	0.010
	Ø 30	<b>XSZB130</b>	0.020

(1) For a 5 m cable replace L2 by L5; for a 10 m cable replace L2 by L10. Please consult our Customer Care Center for availability.

Example: **XS508BLPAL2** becomes **XS508BLPAL5** with a 5 m cable.

(2) For more information, see page 120.

# Inductive proximity sensors

XS range, general purpose

Cylindrical, standard range, flush mountable

Three-wire DC, solid-state output

Characteristics			
Sensor type		XS5●●B1●●M8, XS5●●B1●●M12 XS5●●BL●●M8, XS5●●BL●●M12	XS5●●B1●●L2 XS5●●BL●●L2
Product certifications		cULus, CE, UKCA, E2	
Connection	Connector	M8 on Ø 6.5 and Ø 8, M12 on Ø 8, Ø 12, Ø 18 and Ø 30	–
	Pre-cabled	–	Length: 2 m
Operating zone	Ø 6.5 and Ø 8	mm	0...1.2
	Ø 12	mm	0...1.6
	Ø 18	mm	0...4
	Ø 30	mm	0...8
Differential travel		%	1...15 of effective sensing distance (Sr)
Degree of protection	Conforming to IEC 60529	IP 65 and IP 67	IP 65 and IP 68 (except Ø 6.5 and Ø 8: IP 67)
	Conforming to DIN 40050	IP 69K for Ø 12 to Ø 30	–
Storage temperature		°C	-40...+85
Operating temperature		°C	-25...+70
Materials	Case	Nickel plated brass (except XS506 and XS508: stainless steel, grade 303)	
	Sensing face	PPS	
	Cable	–	PVC 3 x 0.34 mm <sup>2</sup> except <b>XS506</b> and <b>XS508</b> : 3 x 0.11 mm <sup>2</sup>
Vibration resistance	Conforming to IEC 60068-2-6	25 gn, amplitude ± 2 mm (f = 10 to 50 Hz)	
Shock resistance	Conforming to IEC 60068-2-27	50 gn, duration 11 ms	
Output state indication		Yellow LED: 4 viewing ports at 90°	Yellow LED: annular
Rated supply voltage		V	⎓ 12...48 for XS5●●BL (Ø 12, 18, and 30) ⎓ 12...24 for XS5●●B1, XS508BL with protection against reverse polarity
Voltage limits (including ripple)		V	⎓ 10...58 for XS5●●BL (Ø 12, 18, and 30) ⎓ 10...36 for XS5●●B1, XS508BL
Insulation class		M12: □ M8: III	□
Switching capacity		mA	≤ 200 with overload and short-circuit protection
Voltage drop, closed state		V	≤ 2
Current consumption, no-load		mA	≤ 10
Maximum switching frequency	<b>XS506, XS508, XS512</b>	Hz	5000
	<b>XS518</b>	Hz	2000
	<b>XS530</b>	Hz	1000
Delays	First-up	ms	≤ 10
	Response	ms	≤ 0.1: <b>XS506, XS508</b> and <b>XS512</b> ≤ 0.15: <b>XS518</b> ≤ 0.3: <b>XS530</b>
	Recovery	ms	≤ 0.1: <b>XS506, XS508</b> and <b>XS512</b> ≤ 0.35: <b>XS518</b> ≤ 0.7: <b>XS530</b>



# Inductive proximity sensors

XS range, general purpose

Cylindrical, standard range, flush mountable

Three-wire DC, solid-state output

## Wiring schemes

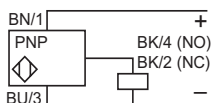
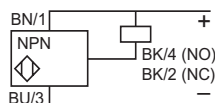
Connector	Pre-cabled	PNP	NPN
<b>M8</b>  <b>M12</b> 	BU: Blue BN: Brown BK: Black		

For M8 connector, NO and NC outputs on terminal 4

## Setting-up

### Minimum mounting distances (mm)

Flush mountable sensors	Side by side	Face to face	Facing a metal object
Ø 6.5	$e \geq 3$	$e \geq 18$	$e \geq 4.5$
Ø 8	$e \geq 3$	$e \geq 18$	$e \geq 4.5$
Ø 12	$e \geq 4$	$e \geq 24$	$e \geq 6$
Ø 18	$e \geq 10$	$e \geq 60$	$e \geq 15$
Ø 30	$e \geq 20$	$e \geq 120$	$e \geq 30$

## Dimensions

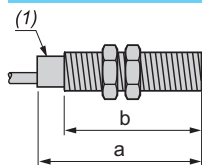

(1) LED

Sensors		Pre-cabled (mm)		M8 connector (mm)		M12 connector (mm)	
Short case model		a	b	a	b	a	b
Ø 6.5	<b>XS506B1</b>	34	–	42	–	45	–
Ø 8	<b>XS508B1</b>	34	25	42	27	45	23
Ø 12	<b>XS512B1</b>	37	25	–	–	50	30
Ø 18	<b>XS518B1</b>	39	28	–	–	50	28
Ø 30	<b>XS530B1</b>	43	32	–	–	54	32

Sensors		Pre-cabled (mm)		M12 connector (mm)	
Long case model		a	b	a	b
Ø 8	<b>XS508BL</b>	51	42	61	40
Ø 12	<b>XS512BL</b>	53	42	61	42
Ø 18	<b>XS518BL</b>	62	52	74	52
Ø 30	<b>XS530BL</b>	62	52	74	52

# Inductive proximity sensors

XS range, general purpose

Cylindrical, standard range, flush mountable

Two-wire DC



XS512B1●●L2

XS-XT\_515\_CPODA2016161



XS512B1●●M12

XS-XT\_515\_CPODA2016B34



XSZB1●●

XS\_515\_CPFJ/IR16004

### Sensors, 2-wire 12...24 V, short case model

Sensing distance (Sn) mm	Function	Connection	Reference	Weight (kg)
<b>Ø 8, threaded M8 x 1</b>				
1.5	NC	Pre-cabled (L = 2 m) (1)	<b>XS508BSCBL2</b>	0.035
<b>Ø 12, threaded M12 x 1</b>				
2	NO	M12 connector	<b>XS512BSDAM12</b>	0.035
<b>Ø 18, threaded M18 x 1</b>				
5	NO	M12 connector	<b>XS518BSDAM12</b>	0.060
<b>Ø 30, threaded M30 x 1.5</b>				
10	NO terminals 1 & 4 (2)	M12 connector	<b>XS530BSCAM12</b>	0.145

### Accessories (3)

Description	For use with sensors (mm)	Reference	Weight (kg)
Fixing clamps	Ø 8	<b>XSZB108</b>	0.006
	Ø 12	<b>XSZB112</b>	0.006
	Ø 18	<b>XSZB118</b>	0.010
	Ø 30	<b>XSZB130</b>	0.020

(1) For a 5 m cable replace L2 by L5; for a 10 m cable replace L2 by L10. Please consult our Customer Care Center for availability.

Example: XS508BSCBL2 becomes XS508BSCBL5 with a 5 m cable.

(2) The NO output is connected to terminals 1 and 4 of the M12 connector.

(3) For more information, see page 120.

# Inductive proximity sensors

XS range, general purpose

Cylindrical, standard range, flush mountable

Two-wire DC

103947



XS512BS●●L2

103993



XS5●●BS●●M12

PF100297



XS5●●B1●●L01C

XS\_515\_CPF/IR16004



XSZB1●●

## Sensors, 2-wire $\overline{\text{DC}}$ 12...48 V, long case model

Sensing distance (Sn) mm	Function	Connection	Reference	Weight (kg)
<b>Ø 8, threaded M8 x 1</b>				
1.5	NO	Pre-cabled (L = 2 m) (1)	<b>XS508B1DAL2</b>	0.035
		M12 connector	<b>XS508B1DAM12</b>	0.025
	NO terminals 1 & 4 (2)	Remote M12 connector	<b>XS508B1CAL08M12</b>	0.050
<b>Ø 12, threaded M12 x 1</b>				
2	NO	Pre-cabled (L = 2 m) (1)	<b>XS512B1DAL2</b>	0.075
		M12 connector	<b>XS512B1DAM12</b>	0.035
	NO terminals 1 & 4 (2)	M12 connector	<b>XS512B1CAM12</b>	0.035
		Remote M12 connector	<b>XS512B1CAL08M12</b>	0.060
NC	Pre-cabled (L = 2 m) (1)	<b>XS512B1DBL2</b>	0.075	
<b>Ø 18, threaded M18 x 1</b>				
5	NO	Pre-cabled (L = 2 m) (1)	<b>XS518B1DAL2</b>	0.120
		Remote EN 175301-803-A connector	<b>XS518B1DAL01C</b>	0.085
		M12 connector	<b>XS518B1DAM12</b>	0.060
	NO terminals 1 & 4 (2)	M12 connector	<b>XS518B1CAM12</b>	0.060
		Remote M12 connector	<b>XS518B1CAL08M12</b>	0.085
	NC	Pre-cabled (L = 2 m) (1)	<b>XS518B1DBL2</b>	0.120
M12 connector	<b>XS518B1DBM12</b>	0.060		
<b>Ø 30, threaded M30 x 1.5</b>				
10	NO	Pre-cabled (L = 2 m) (1)	<b>XS530B1DAL2</b>	0.205
		M12 connector	<b>XS530B1DAM12</b>	0.145
	NO terminals 1 & 4 (2)	M12 connector	<b>XS530B1CAM12</b>	0.145
		NC	Pre-cabled (L = 2 m) (1)	<b>XS530B1DBL2</b>

## Accessories (3)

Description	For use with sensors (mm)	Reference	Weight (kg)
Fixing clamps	Ø 8	<b>XSZB108</b>	0.006
	Ø 12	<b>XSZB112</b>	0.006
	Ø 18	<b>XSZB118</b>	0.010
	Ø 30	<b>XSZB130</b>	0.020

(1) For a 5 m cable replace L2 by L5; for a 10 m cable replace L2 by L10. Please consult our Customer Care Center for availability.

Example: XS508B1DAL2 becomes **XS508B1DAL5** with a 5 m cable.

(2) The NO output is connected to terminals 1 and 4 of the M12 connector.

(3) For more information, see page 120.

# Inductive proximity sensors

XS range, general purpose

Cylindrical, standard range, flush mountable

Two-wire DC

Characteristics			
Sensor type		XS5●●B1●●M12, XS5●●BS●●M12	XS5●●B1D●L2, XS5●●BS●●L2
Product certifications		cULus, CE, UKCA	
Connection	Connector	M12	–
	Pre-cabled	–	Length: 2 m
	Remote connector	M12 (L01M12), EN 175301-803-A (L01C) and M12 (L08M12) connectors on 0.80 m flying lead	
Operating zone	Ø 8	mm	0...1.2
	Ø 12	mm	0...1.6
	Ø 18	mm	0...4
	Ø 30	mm	0...8
Differential travel		%	1...15 of effective sensing distance (Sr)
Degree of protection		Conforming to IEC 60529	IP 65 and IP 67 IP 65 and IP 68 (except Ø 8: IP 67)
Storage temperature		°C	-40...+85
Operating temperature		°C	-25...+70; TF products: -40...+70
Materials	Case	Nickel plated brass (except XS506 and XS508B1: stainless steel, grade 303)	
	Sensing face	PPS	
	Cable	–	PVC 2 x 0.34 mm <sup>2</sup> (except XS508: 2 x 0.11 mm <sup>2</sup> ) PUR available (1)
Vibration resistance		Conforming to IEC 60068-2-6	25 gn, amplitude ± 2 mm (f = 10 to 55 Hz)
Shock resistance		Conforming to IEC 60068-2-27	50 gn, duration 11 ms
Output state indication			Yellow LED: 4 viewing ports at 90° Yellow LED: annular
Rated supply voltage		V	--- 12...48 non polarised for XS5●●B1● --- 12...24 non polarised for XS5●●BS (except Ø 8 short: polarised) with protection against reverse polarity
Voltage limits (including ripple)		V	--- 10...58 for XS5●●B1● --- 10...36 for XS5●●BS
Insulation class			□ □
Switching capacity		mA	1.5...100 with overload and short-circuit protection
Voltage drop, closed state		V	≤ 4.2
Residual current, open state		mA	≤ 0.5
Maximum switching frequency	XS508	Hz	1000 for XS5●●BS, 1400 for XS5●●B1●
	XS512	Hz	1000
	XS518	Hz	1200
	XS530	Hz	1300
Delays	First-up	ms	≤ 10
	Response	ms	≤ 0.5: XS508 and XS512 ≤ 0.6: XS518 ≤ 0.6: XS530
	Recovery	ms	≤ 0.2 (except XS530 ≤ 0.4)

(1) For PUR cable, replace the letter L in the reference by P. Example: XS508BSCAL2 becomes XS508BSCAP2 with a PUR cable.

# Inductive proximity sensors

XS range, general purpose

Cylindrical, standard range, flush mountable

Two-wire DC

## Wiring schemes

Connector	Pre-cabled	2-wire $\overline{\text{---}}$ non polarised		
<b>M12</b> 	BU: Blue BN: Brown	<b>NO output</b> <b>XS5●●B●DA●●●</b>	<b>XS5●●B1CA●●●</b>	<b>NC output</b> <b>XS5●●B●DB●●●</b>
		2-wire $\overline{\text{---}}$ polarised		
		<b>NO output</b> <b>XS5●●BSCA●●●</b>	<b>NC output</b> <b>XS5●●BSCB●●●</b>	

## Remote connectors L01B, L01C, L01G, U78

### Screw terminal (L01B)

The terminal numbering differs according to the version (2-wire  $\overline{\text{---}}$ , 3-wire  $\overline{\text{---}}$ , 2-wire  $\overline{\text{~}}$ ).

### EN 175301-803-A (L01C)

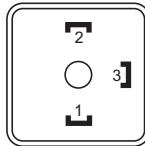

The NO or NC outputs are connected to terminal 2.

### M18 (L01G)

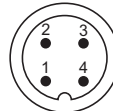

### 7/8" (U78)

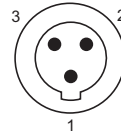

Terminal 1: not connected  
Terminal 2: +/-  
Terminal 3: +/-

## Setting-up

### Minimum mounting distances (mm)

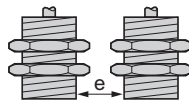

#### Side by side

Ø 8	$e \geq 3$
Ø 12	$e \geq 4$
Ø 18	$e \geq 10$
Ø 30	$e \geq 20$

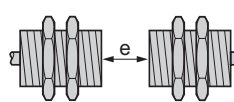

#### Face to face

Ø 8	$e \geq 18$
Ø 12	$e \geq 24$
Ø 18	$e \geq 60$
Ø 30	$e \geq 120$

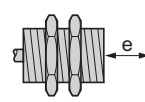

#### Facing a metal object

Ø 8	$e \geq 4.5$
Ø 12	$e \geq 6$
Ø 18	$e \geq 15$
Ø 30	$e \geq 30$

## Dimensions

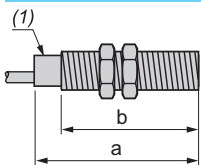

(1) LED

Sensors		Pre-cabled (mm)		M8 connector (mm)		M12 connector (mm)	
		a	b	a	b	a	b
<b>Short case model</b>							
Ø 8	XS508BS	33	25	42	26	45	24
Ø 12	XS512BS	35	25	—	—	50	30
Ø 18	XS518BS	40	28	—	—	50	28
Ø 30	XS530BS	44	32	—	—	55	32
<b>Long case model</b>							
Ø 8	XS508B1	51	42	62	40	—	—
Ø 12	XS512B1	54	42	61	42	—	—
Ø 18	XS518B1	56	44	64	44	—	—
Ø 30	XS530B1	54	42	72	41	—	—

# Inductive proximity sensors

XS range, general purpose

Cylindrical, standard range, flush mountable

Two-wire AC or DC <sup>(1)</sup>



XS512B1M●L2



XS518B1M●U20



XS530B1●●L2



XSZB1●●

### Sensors, 2-wire $\sphericalangle$ 24-240 V, long case model

Ø 12, threaded M12 x 1				
Sensing distance (Sn) mm	Function	Connection	Reference	Weight (kg)
2	NO	Pre-cabled (L = 2 m) (2)	<b>XS512B1MAL2</b>	0.075
		1/2"-20 UNF connector	<b>XS512B1MAU20</b>	0.025
	NC	Pre-cabled (L = 2 m) (2)	<b>XS512B1MBL2</b>	0.075
		1/2"-20 UNF connector	<b>XS512B1MBU20</b>	0.025

Ø 18, threaded M18 x 1				
Sensing distance (Sn) mm	Function	Connection	Reference	Weight (kg)
5	NO	Pre-cabled (L = 2 m) (2)	<b>XS518B1MAL2</b>	0.100
		1/2"-20 UNF connector	<b>XS518B1MAU20</b>	0.060
	NC	Pre-cabled (L = 2 m) (2)	<b>XS518B1MBL2</b>	0.100
		1/2"-20 UNF connector	<b>XS518B1MBU20</b>	0.060

Ø 30, threaded M30 x 1.5				
Sensing distance (Sn) mm	Function	Connection	Reference	Weight (kg)
10	NO	Pre-cabled (L = 2 m) (2)	<b>XS530B1MAL2</b>	0.205
		1/2"-20 UNF connector	<b>XS530B1MAU20</b>	0.145
	NC	Pre-cabled (L = 2 m) (2)	<b>XS530B1MBL2</b>	0.205

### Accessories <sup>(3)</sup>

Description	For use with sensors (mm)	Reference	Weight (kg)
Fixing clamps	Ø 12	<b>XSZB112</b>	0.006
	Ø 18	<b>XSZB118</b>	0.010
	Ø 30	<b>XSZB130</b>	0.020

(1) Ø8 plastic, double insulation version available (see page 68).

(2) For a 5 m cable replace L2 by L5; for a 10 m cable replace L2 by L10. Please consult our Customer Care Center for availability.

Example: **XS512B1MAL2** becomes **XS512B1MAL5** with a 5 m cable.

(3) For more information, see page 120.

# Inductive proximity sensors

XS range, general purpose

Cylindrical, standard range, flush mountable

Two-wire AC or DC

Characteristics		XS5●●B1M●U20	XS5●●B1M●L2
Sensor type		cULus, CE, UKCA	
Product certifications	Connector	1/2"-20 UNF	–
	Pre-cabled	–	Length: 2 m
Operating zone	Ø 12	mm	0...1.6
	Ø 18	mm	0...4
	Ø 30	mm	0...8
Differential travel		%	1...15 of effective sensing distance (Sr)
Degree of protection	Conforming to IEC 60529	IP 65 and IP 67	IP 65 and IP 68
	Conforming to DIN 40050	IP 69K	–
Storage temperature		°C	-40...+85
Operating temperature		°C	-25...+70
Materials	Case	Nickel plated brass	
	Sensing face	PPS	
	Cable	–	PVC 2 x 0.34 mm <sup>2</sup>
Vibration resistance	Conforming to IEC 60068-2-6	25 gn, amplitude ± 2 mm (f = 10 to 55 Hz)	
Shock resistance	Conforming to IEC 60068-2-27	50 gn, duration 11 ms	
Output state indication		Yellow LED: 4 viewing ports at 90°	Yellow LED: annular
Rated supply voltage		V	~ or ≐ 24...240 (~ 50/60 Hz)
Voltage limits (including ripple)		V	~ or ≐ 20...264
Insulation class		I	I
Switching capacity	XS512B1M●●●	mA	5...200 (1)
	XS518B1M●●●, XS530B1M●●●	mA	~ 5...300 or ≐ 5...200 (1)
Voltage drop, closed state		V	≤ 5.5
Residual current, open state		mA	≤ 0.8
Maximum switching frequency	XS512B1●●●, XS518B1M●●●	Hz	~ 25 or ≐ 1000
	XS530B1M●●●	Hz	~ 25 or ≐ 500
Delays	First-up	ms	≤ 20 XS512B1M●●● ≤ 25 XS518B1M●●● and XS530B1M●●●
	Response	ms	≤ 0.5
	Recovery	ms	≤ 0.2 XS512B1M●●● ≤ 0.5 XS518B1M●●● ≤ 2 XS518B1M●●●

(1) It is essential to connect a 0.4 A "quick-blow" fuse in series with the load.

## Wiring schemes

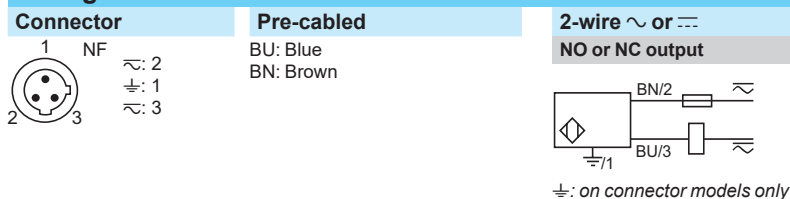

## Setting-up

### Minimum mounting distances (mm)

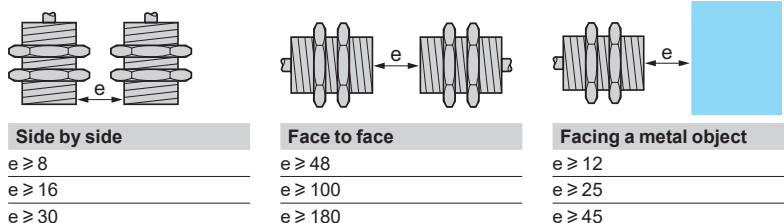

## Dimensions

Sensor	XS6		Connector (mm)	
	Pre-cabled (mm)		a	b
XS512B1M	a	b	62	42
XS518B1M	62	52	73	52
XS530B1M	62	52	73	52

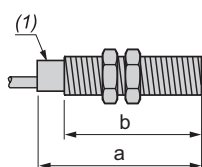

(1) LED

# Inductive proximity sensors

XS range, general purpose

Cylindrical, increased range, flush mountable

Three-wire DC, solid-state output



## Sensors, 3-wire 12...24 V, short case model

Sensing distance (Sn) mm	Function	Output	Connection	Sold in lots of	Unit reference	Weight (kg)
<b>Ø 6.5, plain</b>						
2.5	NO	PNP	Pre-cabled (L = 2 m) (1)	1	XS106B3PAL2	0.060
			M8 connector	1	XS106B3PAM8	0.030
			M12 connector	1	XS106B3PAM12	0.050
NC	PNP	Pre-cabled (L = 2 m) (1)	1	XS106B3PBL2	0.060	
		M8 connector	1	XS106B3PBM8	0.030	
<b>Ø 8, threaded M8 x 1</b>						
2.5	NO	PNP	Pre-cabled (L = 2 m) (1)	1	XS108B3PAL2	0.070
			M8 connector	1	XS108B3PAM8	0.030
			M12 connector	1	XS108B3PAM12	0.060
	NC	PNP	Pre-cabled (L = 2 m) (1)	1	XS108B3PBL2	0.070
			M8 connector	1	XS108B3PBM8	0.030
			M12 connector	1	XS108B3PBM12	0.060
NPN	PNP	Pre-cabled (L = 2 m) (1)	1	XS108B3NAL2	0.070	
		M8 connector	1	XS108B3NAM8	0.030	
		M12 connector	1	XS108B3NAM12	0.060	
<b>Ø 12, threaded M12 x 1</b>						
4	NO	PNP	Pre-cabled (L = 2 m) (1)	1	XS112B3PAL2	0.090
			M12 connector	1	XS112B3PAM12	0.030
			NPN	PNP	Pre-cabled (L = 2 m) (1)	1
	M12 connector	1			XS112B3NAM12	0.030
	NC	PNP			Pre-cabled (L = 2 m) (1)	1
			M12 connector	1	XS112B3PBM12	0.030

(1) For a 5 m long cable replace L2 by L5. Please consult our Customer Care Center for availability.  
Example: XS106B3PAL2 becomes XS106B3PAL5 with a 5 m cable.

# Inductive proximity sensors

XS range, general purpose

Cylindrical, increased range, flush mountable

Three-wire DC, solid-state output



XS118B3●●M12



XS118B3●●L2



XS130B3●●L2



XSZB1●●

## Sensors, 3-wire $\overline{\text{---}}$ 12...24 V, short case model (continued)

Sensing distance (Sn) mm	Function	Output	Connection	Sold in lots of	Unit reference	Weight (kg)
<b>Ø 18, threaded M18 x 1</b>						
8	NO	PNP	Pre-cabled (L = 2 m) (1)	1	<b>XS118B3PAL2</b>	0.110
			M12 connector	1	<b>XS118B3PAM12</b>	0.060
	NPN	PNP	Pre-cabled (L = 2 m) (1)	1	<b>XS118B3NAL2</b>	0.110
			M12 connector	1	<b>XS118B3NAM12</b>	0.060
NC	PNP	Pre-cabled (L = 2 m) (1)	1	<b>XS118B3PBL2</b>	0.110	
		M12 connector	1	<b>XS118B3PBM12</b>	0.060	

## Ø 30, threaded M30 x 1.5

15	NO	PNP	Pre-cabled (L = 2 m) (1)	1	<b>XS130B3PAL2</b>	0.180
			M12 connector	1	<b>XS130B3PAM12</b>	0.130
	NPN	PNP	Pre-cabled (L = 2 m) (1)	1	<b>XS130B3NAL2</b>	0.180
			M12 connector	1	<b>XS130B3NAM12</b>	0.130
NC	PNP	Pre-cabled (L = 2 m) (1)	1	<b>XS130B3PBL2</b>	0.180	
		M12 connector	1	<b>XS130B3PBM12</b>	0.130	

## Accessories (2)

Description	For use with sensors (mm)	Reference	Weight (kg)
Fixing clamps	Ø 6.5 (plain)	<b>XSZB165</b>	0.005
	Ø 8 (M8 x1)	<b>XSZB108</b>	0.006
	Ø 12 (M12 x1)	<b>XSZB112</b>	0.006
	Ø 18 (M18 x1)	<b>XSZB118</b>	0.010
	Ø 30 (M30 x 1.5)	<b>XSZB130</b>	0.020

(1) For a 5 m cable, replace L2 by L5. Please consult our Customer Care Center for availability.  
Example: XS118B3PAL2 becomes **XS118B3PAL5** with a 5 m cable.

(2) For more information, see page 120.

# Inductive proximity sensors

XS range, general purpose

Cylindrical, increased range, flush mountable

Three-wire DC, solid-state output



XS608B1●●L2

Sensors, 3-wire $\overline{\text{---}}$ 12...24 V, long case model					
Sensing distance (Sn) mm	Function	Output	Connection	Reference	Weight (kg)
<b>Ø 8, threaded M8 x 1</b>					
2.5	NO	PNP	Pre-cabled (L = 2 m) (1)	XS608B1PAL2	0.035
			M8 connector	XS608B1PAM8	0.015
			M12 connector	XS608B1PAM12	0.015
		NPN	Pre-cabled (L = 2 m) (1)	XS608B1NAL2	0.035
			M8 connector	XS608B1NAM8	0.015
			M12 connector	XS608B1NAM12	0.015
4	NC	PNP	Pre-cabled (L = 2 m) (1)	XS608B1PBL2	0.035
			M8 connector	XS608B1PBM8	0.015
			M12 connector	XS608B1PBM12	0.015
		NPN	Pre-cabled (L = 2 m) (1)	XS608B1NBL2	0.035
			M8 connector	XS608B1NBM8	0.015
			M12 connector	XS608B1NBM12	0.015



XS612B1●●M12

Sensors, 3-wire $\overline{\text{---}}$ 12...48 V, long case model					
Sensing distance (Sn) mm	Function	Output	Connection	Reference	Weight (kg)
<b>Ø 12, threaded M12 x 1</b>					
4	NO	PNP	Pre-cabled (L = 2 m) (1)	XS612B1PAL2	0.075
			M12 connector	XS612B1PAM12	0.020
			M12 connector	XS612B1NAM12	0.020
		NPN	Pre-cabled (L = 2 m) (1)	XS612B1NAL2	0.075
			M12 connector	XS612B1NAM12	0.020
			M12 connector	XS612B1NAM12	0.020
4	NC	PNP	Pre-cabled (L = 2 m) (1)	XS612B1PBL2	0.075
			M12 connector	XS612B1PBM12	0.020
			M12 connector	XS612B1PBM12	0.020
		NPN	Pre-cabled (L = 2 m) (1)	XS612B1NBL2	0.075
			M12 connector	XS612B1NBM12	0.020
			M12 connector	XS612B1NBM12	0.020



XS618B1●●L01C

<b>Ø 18, threaded M18 x 1</b>					
8	NO	PNP	Pre-cabled (L = 2 m) (1)	XS618B1PAL2	0.100
			M12 connector	XS618B1PAM12	0.040
			Remote EN 175301-803-A connector	XS618B1PAL01C	0.100
		NPN	Pre-cabled (L = 2 m) (1)	XS618B1NAL2	0.100
			M12 connector	XS618B1NAM12	0.040
			M12 connector	XS618B1NAM12	0.040
8	NC	PNP	Pre-cabled (L = 2 m) (1)	XS618B1PBL2	0.100
			M12 connector	XS618B1PBM12	0.040
			M12 connector	XS618B1PBM12	0.040
		NPN	Pre-cabled (L = 2 m) (1)	XS618B1NBL2	0.100
			M12 connector	XS618B1NBM12	0.040
			M12 connector	XS618B1NBM12	0.040

<b>Ø 30, threaded M30 x 1.5</b>					
15	NO	PNP	Pre-cabled (L = 2 m) (1)	XS630B1PAL2	0.205
			M12 connector	XS630B1PAM12	0.145
			Remote EN 175301-803-A connector	XS630B1PAL01C	0.205
		NPN	Pre-cabled (L = 2 m) (1)	XS630B1NAL2	0.205
			M12 connector	XS630B1NAM12	0.145
			M12 connector	XS630B1NAM12	0.145
15	NC	PNP	Pre-cabled (L = 2 m) (1)	XS630B1PBL2	0.205
			M12 connector	XS630B1PBM12	0.145
			M12 connector	XS630B1PBM12	0.145
		NPN	Pre-cabled (L = 2 m) (1)	XS630B1NBL2	0.205
			M12 connector	XS630B1NBM12	0.145
			M12 connector	XS630B1NBM12	0.145

Accessories (2)			
Description	For use with sensors (mm)	Reference	Weight (kg)
Fixing clamps	Ø 8	XSZB108	0.006
	Ø 12	XSZB112	0.006
	Ø 18	XSZB118	0.010
	Ø 30	XSZB130	0.020

(1) For a 5 m long cable replace L2 by L5; for a 10 m long cable replace L2 by L10. Please consult our Customer Care Center for availability.

Example: XS608B1PAL2 becomes XS608B1PAL5 with a 5 m cable.

(2) For more information, see page 120.

# Inductive proximity sensors

XS range, general purpose

Cylindrical, increased range, flush mountable

Three-wire DC, solid-state output

Characteristics		XS1/XS6●●B●●M8	XS1/XS6●●B●●M12	XS1/XS6●●B●●L2
Sensor type				
Product certifications	Ø 6.5 and Ø 8 Ø 12, 18 and 30	cULus, CE, UKCA cULus, CE, UKCA, E2		
Connection	Connector	M8	M12	–
	Pre-cabled	–	–	Length 2 m
	Remote connector	Screw terminal (L01B), EN 175301-803-A (L01C) and M18 (L01G) remote connectors on 0.15 m flying lead		
Operating zone (1)	Ø 6.5 and Ø 8	mm	0...2	
	Ø 12	mm	0...3.2	
	Ø 18	mm	0...6.4	
	Ø 30	mm	0...12	
Differential travel		%	1...15 of effective sensing distance (Sr)	
Degree of protection	Conforming to IEC 60529		IP 65 and IP 67	IP 65 and IP 68 except Ø 6.5 and Ø 8: IP 67
	Conforming to DIN 40050		IP 69K	–
Storage temperature		°C	-40...+85	
Operating temperature		°C	-25...+70	
Materials	Case		Nickel plated brass (except Ø 6.5 and Ø 8: stainless steel, grade 303)	
	Sensing face		PPS	
	Cable		–	PVC 3 x 0.34 mm <sup>2</sup> except Ø 6.5 and 8: 3 x 0.11 mm <sup>2</sup>
Vibration resistance	Conforming to IEC 60068-2-6		25 gn, amplitude ± 2 mm (f = 10 to 55 Hz)	
Shock resistance	Conforming to IEC 60068-2-27		50 gn, duration 11 ms	
Output state indication			Yellow LED, 4 viewing ports at 90°	Yellow LED, annular
Rated supply voltage		V	XS1, XS608: --- 12...24 with protection against reverse polarity XS6: --- 12...48 with protection against reverse polarity (Ø 12, 18, 30)	
Voltage limits (including ripple)		V	XS1, XS608: --- 10...36; XS6: --- 10...58 (Ø 12, 18, 30)	
Insulation class			III	III
Switching capacity		mA	≤ 200 with overload and short-circuit protection	
Voltage drop, closed state		V	≤ 2	
Current consumption, no-load		mA	≤ 10	
Maximum switching frequency	Ø 6.5, Ø 8 and Ø 12	Hz	2500	
	Ø 18	Hz	1000	
	Ø 30	Hz	500	
Delays	First-up	ms	≤ 10	
	Response	ms	≤ 0.2 for Ø 6.5, Ø 8 and Ø 12, ≤ 0.3 for Ø 18, ≤ 0.6 for Ø 30	
	Recovery	ms	≤ 0.2 for Ø 6.5, Ø 8 and Ø 12, ≤ 0.7 for Ø 18, ≤ 1.4 for Ø 30	

(1) Detection curves, see page 128.

## Wiring schemes

### Connector (1)

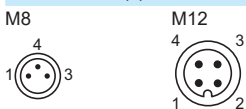

### Pre-cabled

BU: Blue  
BN: Brown  
BK: Black

### PNP

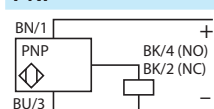

### NPN

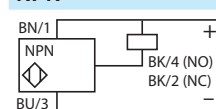

For M8 connector, NO and NC outputs on terminal 4

(1) For pin arrangement of remote connectors L01B, L01C and L01G, see page 31.

## Setting-up

### Minimum mounting distances (mm)

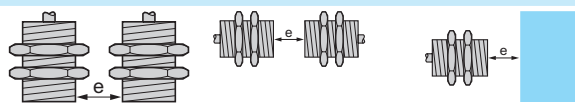

Sensors	Side by side	Face to face	Facing a metal object
Ø 6.5	e ≥ 5	e ≥ 30	e ≥ 8
Ø 8	e ≥ 5	e ≥ 30	e ≥ 8
Ø 12	e ≥ 8	e ≥ 48	e ≥ 12
Ø 18	e ≥ 16	e ≥ 100	e ≥ 25
Ø 30	e ≥ 30	e ≥ 180	e ≥ 45

## Dimensions

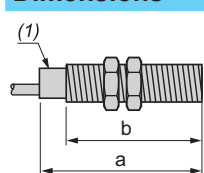

(1) LED

Sensors		Pre-cabled (mm)		M8 connector (mm)		M12 connector (mm)	
Short case model		a	b	a	b	a	b
Ø 6.5	XS106B3	34	–	42	–	45	–
Ø 8	XS108B3	34	25	42	27	45	23
Ø 12	XS112B3	35	25	–	–	50	30
Ø 18	XS118B3	39	28	–	–	50	28
Ø 30	XS130B3	43	32	–	–	55	32

Sensors		Pre-cabled (mm)		M8 connector (mm)		M12 connector (mm)	
Long case model		a	b	a	b	a	b
Ø 8	XS608B1	51	42	58	43	61	40
Ø 12	XS612B1	53	42	–	–	61	42
Ø 18	XS618B1	62	52	–	–	74	52
Ø 30	XS630B1	62	52	–	–	74	52

## Inductive proximity sensors

XS range, general purpose

Cylindrical, increased range, flush mountable

Two-wire DC, solid-state output



XS608B3●●L2



XS608B3●●L2



XS6●●B1●●L2



XS6●●B1●●M12



XSZB1●●

### Sensors, 2-wire $\overline{\text{DC}}$ 12...24 V, short case model

Sensing distance (Sn) mm	Function	Connection	Reference	Weight (kg)
<b>Ø 6.5, plain</b>				
2.5	NO	Pre-cabled (L = 2 m) (1)	XS606B3CAL2	0.060
	NC	Pre-cabled (L = 2 m) (1)	XS606B3CBL2	0.060
<b>Ø 8, threaded M8 x 1</b>				
2.5	NO	Pre-cabled (L = 2 m) (1)	XS608B3CAL2	0.070
<b>Ø 12, threaded M12 x 1</b>				
4	NO	Pre-cabled (L = 2 m) (1)	XS612B3DAL2	0.090
		M12 connector	XS612B3DAM12	0.030
	NC	Pre-cabled (L = 2 m) (1)	XS612B3DBL2	0.090
		M12 connector	XS612B3DBM12	0.030
<b>Ø 18, threaded M18 x 1</b>				
8	NO	Pre-cabled (L = 2 m) (1)	XS618B3DAL2	0.110
		M12 connector	XS618B3DAM12	0.060
	NC	Pre-cabled (L = 2 m) (1)	XS618B3DBL2	0.110
		M12 connector	XS618B3DBM12	0.060
<b>Ø 30, threaded M30 x 1.5</b>				
15	NO	Pre-cabled (L = 2 m) (1)	XS630B3DAL2	0.180
		M12 connector	XS630B3DAM12	0.130

### Sensors, 2-wire $\overline{\text{DC}}$ 12...48 V, long case model

Sensing distance (Sn) mm	Function	Connection	Reference	Weight (kg)
<b>Ø 6.5, plain</b>				
2.5	NC	Pre-cabled (L = 2 m) (1)	XS606B1DBL2	0.060
<b>Ø 8, threaded M8 x 1</b>				
2.5	NO	Pre-cabled (L = 2 m) (1)	XS608B1DAL2	0.035
		M12 connector	XS608B1DAM12	0.015
	NC	Pre-cabled (L = 2 m) (1)	XS608B1DBL2	0.035
<b>Ø 12, threaded M12 x 1</b>				
4	NO	Pre-cabled (L = 2 m) (1)	XS612B1DAL2	0.180
		M12 connector	XS612B1DAM12	0.020
	NC	M12 connector	XS612B1DBM12	0.020
<b>Ø 18, threaded M18 x 1</b>				
8	NO	Pre-cabled (L = 2 m) (1)	XS618B1DAL2	0.100
		M12 connector	XS618B1DAM12	0.040
	NC	Pre-cabled (L = 2 m) (1)	XS618B1DBL2	0.100
		M12 connector	XS618B1DBM12	0.040
<b>Ø 30, threaded M30 x 1.5</b>				
15	NO	Pre-cabled (L = 2 m) (1)	XS630B1DAL2	0.205
		M12 connector	XS630B1DAM12	0.145
	NC	M12 connector	XS630B1DBM12	0.145

### Accessories (2)

Description	For use with sensors (mm)	Reference	Weight (kg)
Fixing clamps	Ø 6.5 (plain)	XSZB165	0.005
	Ø 8 (M8 x1)	XSZB108	0.006
	Ø 12 (M12 x1)	XSZB112	0.006
	Ø 18 (M18 x1)	XSZB118	0.010
	Ø 30 (M30 x 1.5)	XSZB130	0.020

(1) For a 5 m cable, replace L2 by L5. Please consult our Customer Care Center for availability.  
Example: XS606B3CAL2 becomes XS606B3CAL5 with a 5 m cable.

(2) For more information, see page 120.

# Inductive proximity sensors

XS range, general purpose

Cylindrical, increased range, flush mountable

Two-wire DC, solid-state output

Characteristics			
Sensor type		XS6●●B3●●M12 XS6●●B1D●M12	XS6●●B3●●L2 XS6●●B1D●L2
Product certifications		cULus, CE, UKCA,	
Connection		M12 or remote M12 connector (L01M12) on 0.15 m flying lead	
Connector		Length 2 m	
Pre-cabled			
Operating zone (1)		∅ 6.5 and ∅ 8	mm 0... 2
		∅ 12	mm 0...3.2
		∅ 18	mm 0...6.4
		∅ 30	mm 0...12
Differential travel		%	
Degree of protection		1...15 of effective sensing distance (Sr)	
Conforming to IEC 60529		IP 65 and IP 67	
Conforming to DIN 40050		IP 69K	
Storage temperature		°C -40...+85	
Operating temperature		°C -25...+70	
Materials		Case Nickel plated brass (except XS606B1D or XS608B1D: stainless steel, grade 303)	
Sensing face		PPS	
Cable		PVC 2 x 0.34 mm <sup>2</sup> except ∅ 6.5 and ∅ 8: 2 x 0.11 mm <sup>2</sup>	
Vibration resistance		Conforming to IEC 60068-2-6 25 gn, amplitude ± 2 mm (f = 10 to 55 Hz)	
Shock resistance		Conforming to IEC 60068-2-27 50 gn, duration 11 ms	
Output state indication		Yellow LED, 4 viewing ports at 90°	
Rated supply voltage		V --- 12...48 non polarised for XS6●●B1D --- 12...24 non polarised for XS6●●B3● (except ∅ 6.5 short and ∅ 8 short: polarised), with protection against reverse polarity	
Voltage limits (including ripple)		V --- 10...58 for XS6●●B1D --- 10...36 for XS6●●B3●	
Insulation class		□ □	
Switching capacity		mA ≤ 100 with overload and short-circuit protection	
Voltage drop, closed state		V ≤ 4.2	
Residual current, open state		mA ≤ 0.5 mA	
Maximum switching frequency		∅ 6.5, ∅ 8 Hz 1400 for XS6●●B1D, 1100 for XS6●●B3●	
		∅ 12 Hz 1300	
		∅ 18 Hz 1500	
		∅ 30 Hz 800	
Delays		First-up ms ≤ 10	
		Response ms ≤ 0.5	
		Recovery ms ≤ 0.2 for ∅ 6.5, ∅ 8 and ∅ 12; 0.3 for ∅ 18; 0.6 for ∅ 30	

(1) Detection curves, see page 128.

Wiring schemes		Setting-up			
M12 connector		Minimum mounting distances (mm)			
Pre-cabled					
2-wire --- non polarised					
NO output					
NC output					
2-wire --- polarised					
XS6●●B3CA					
XS6●●B3CB					

Dimensions					
(1) LED					
Sensors		Pre-cabled (mm)		M12 connector (mm)	
Short case model		a	b	a	b
∅ 6.5	XS606B3C	33	—	—	—
∅ 8	XS608B3C	33	25	—	24
∅ 12	XS612B3D	35	25	50	30
∅ 18	XS618B3D	40	28	50	28
∅ 30	XS630B3D	44	32	55	32
Long case model		a	b	a	b
∅ 6.5	XS606B1D	50	—	—	—
∅ 8	XS608B1D	51	42	62	40
∅ 12	XS612B1D	53	42	61	42
∅ 18	XS618B1D	62	52	74	52
∅ 30	XS630B1D	62	52	74	52

# Inductive proximity sensors

XS range, general purpose

Cylindrical, increased range, flush mountable

Two-wire AC or DC <sup>(1)</sup>



XS6●●B1M●L2



XS6●●B1●●U20



XS6●●B1●●L01B (3)



XS6●●B1●●L01C



XS6●●B1●●L01U78



XSZB1●●

## Sensors, 2-wire ~ 24-240 V, long case model

Sensing distance (Sn) mm	Function	Connection	Reference	Weight (kg)
<b>Ø 12, threaded M12 x 1</b>				
4	NO	Pre-cabled (L = 2 m) (2)	<b>XS612B1MAL2</b>	0.075
		1/2"-20 UNF connector	<b>XS612B1MAU20</b>	0.025
	NC	Pre-cabled (L = 2 m) (2)	<b>XS612B1MBL2</b>	0.075
		1/2"-20 UNF connector	<b>XS612B1MBU20</b>	0.025

## Ø 18, threaded M18 x 1

8	NO	Pre-cabled (L = 2 m) (2)	<b>XS618B1MAL2</b>	0.100
		1/2"-20 UNF connector	<b>XS618B1MAU20</b>	0.060
		Remote screw terminal connector	<b>XS618B1MAL01B (3)</b>	0.100
		Remote EN 175301-803-A connector	<b>XS618B1MAL01C</b>	0.100
	NC	Pre-cabled (L = 2 m) (2)	<b>XS618B1MBL2</b>	0.100
		1/2"-20 UNF connector	<b>XS618B1MBU20</b>	0.060

## Ø 30, threaded M30 x 1.5

15	NO	Pre-cabled (L = 2 m) (2)	<b>XS630B1MAL2</b>	0.205
		1/2"-20 UNF connector	<b>XS630B1MAU20</b>	0.145
		Remote screw terminal connector	<b>XS630B1MAL01B (3)</b>	0.205
		Remote EN 175301-803-A connector	<b>XS630B1MAL01C</b>	0.205
	NC	Pre-cabled (L = 2 m) (2)	<b>XS630B1MBL2</b>	0.205
		1/2"-20 UNF connector	<b>XS630B1MBU20</b>	0.145
		Remote screw terminal connector	<b>XS630B1MBL01B (3)</b>	0.205

## Accessories <sup>(4)</sup>

Description	For use with sensors (mm)	Reference	Weight (kg)
Fixing clamps	Ø 12	<b>XSZB112</b>	0.006
	Ø 18	<b>XSZB118</b>	0.010
	Ø 30	<b>XSZB130</b>	0.020

(1) Ø8 plastic, double insulation version available (see page 68).

(2) For a 5 m cable replace L2 by L5; for a 10 m cable replace L2 by L10. Please consult our Customer Care Center for availability.

Example: XS612B1MAL2 becomes XS612B1MAL5 with a 5 m cable.

(3) Protective cable gland included with sensor.

(4) For more information, see page 120.

# Inductive proximity sensors

XS range, general purpose

Cylindrical, increased range, flush mountable

Two-wire AC or DC

Characteristics		XS6●●B1M●U20	XS6●●B1M●L●
Sensor type		cULus, CE, UKCA	
Product certifications		cULus, CE, UKCA	
Connection	Connector	1/2" - 20 UNF	
	Pre-cabled	-	
	Remote connector	Screw terminal (L01B), EN 175301-803-A (L01C) and M18 (L01G) remote connectors on 0.15 m flying lead	
Operating zone (1)	Ø 12	mm	0... 3.2
	Ø 18	mm	0... 6.4
	Ø 30	mm	0... 12
Differential travel		%	
Degree of protection		1...15 of effective sensing distance (Sr)	
Storage temperature	Conforming to IEC 60529	IP 65, IP 67	
	Conforming to DIN 40050	IP 69K	
Operating temperature		°C	
Materials		°C	
Case		Nickel plated brass	
Sensing face		PPS	
Cable		PVC 2 x 0.34 mm <sup>2</sup>	
Vibration resistance	Conforming to IEC 60068-2-6	25 gn, amplitude ± 2 mm (f = 10 to 55 Hz)	
Shock resistance	Conforming to IEC 60068-2-27	50 gn, duration 11 ms	
Output state indication		Yellow LED: annular on pre-cabled version Yellow LED with 4 viewing ports at 90° on connector version	
Rated supply voltage		V	
Voltage limits (including ripple)		V	
Insulation class		I	
Switching capacity	XS612B1M●●●	mA	5...200 (2)
	XS618B1M●●●	mA	~ 5...300 or ~ 5...200 (2)
	XS630B1M●●●	mA	~ 5...300 or ~ 5...200 (2)
Voltage drop, closed state		V	
Residual current, open state		mA	
Maximum switching frequency (DC/AC)	Ø 12	Hz	~ 1000 / ~ 25
	Ø 18	Hz	~ 1000 / ~ 25
	Ø 30	Hz	~ 500 / ~ 25
Delays	First-up	ms	≤ 25 for Ø 18 and Ø 30; ≤ 20 for Ø 12
	Response	ms	≤ 0.5
	Recovery	ms	≤ 0.2 for Ø 12; ≤ 0.5 for Ø 18; ≤ 2 for Ø 30

(1) Detection curves, see page 128.

(2) It is essential to connect a 0.4 A "quick-blow" fuse in series with the load.

## Wiring schemes

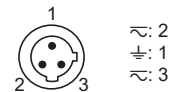
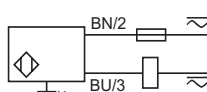
Connector (1)	Pre-cabled	2-wire ~ or ---
1/2"-20 UNF	BU: Blue BN: Brown	NO or NC output
		
		±: on 1/2"-20UNF connector models only

(1) For pin arrangement of remote connectors L01B, L01C and L01G, see page 31.

## Setting-up

### Minimum mounting distances (mm)

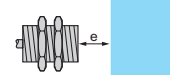
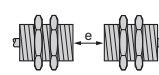
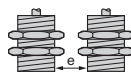

Sensors	Side by side	Face to face	Facing a metal object
Ø 12	e ≥ 8	e ≥ 48	e ≥ 12
Ø 18	e ≥ 16	e ≥ 100	e ≥ 25
Ø 30	e ≥ 30	e ≥ 180	e ≥ 45

## Dimensions

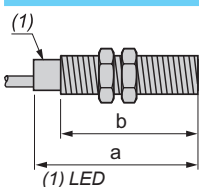

Sensors	Pre-cabled (mm)		Connector (mm)	
	a	b	a	b
Ø 12 XS612B1M●	53	42	61	42
Ø 18 XS618B1M●	62	52	73	52
Ø 30 XS630B1M●	62	52	73	52

# Inductive proximity sensors

XS range, general purpose

Cylindrical, increased range, non-flush mountable

Three-wire DC, solid-state output

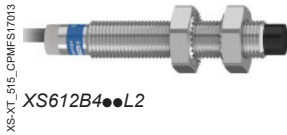

XS-XT\_515\_CPMFES7013

XS612B4●●L2

### Sensors, 3-wire 12...24 V, long case model

Ø 8, threaded M8 x 1

Sensing distance (Sn) mm	Function	Output	Connection	Reference	Weight (kg)
4	NO	PNP	Pre-cabled (L = 2 m)	<b>XS608B4PAL2</b>	0.035
			M8 connector	<b>XS608B4PAM8</b>	0.015
			M12 connector	<b>XS608B4PAM12</b>	0.015
		NPN	Pre-cabled (L = 2 m)	<b>XS608B4NAL2</b>	0.035
			M8 connector	<b>XS608B4NAM8</b>	0.015
			M12 connector	<b>XS608B4NAM12</b>	0.015
	NC	PNP	Pre-cabled (L = 2 m)	<b>XS608B4PBL2</b>	0.035
			M8 connector	<b>XS608B4PBM8</b>	0.015
			M12 connector	<b>XS608B4PBM12</b>	0.015
		NPN	Pre-cabled (L = 2 m)	<b>XS608B4NBL2</b>	0.035
			M8 connector	<b>XS608B4NBM8</b>	0.015
			M12 connector	<b>XS608B4NBM12</b>	0.015

### Sensors, 3-wire 12...48 V, long case model

Ø 12, threaded M12 x 1

Sensing distance (Sn) mm	Function	Output	Connection	Reference	Weight (kg)
7	NO	PNP	Pre-cabled (L = 2 m) (1)	<b>XS612B4PAL2</b>	0.075
			M12 connector	<b>XS612B4PAM12</b>	0.020
		NPN	Pre-cabled (L = 2 m) (1)	<b>XS612B4NAL2</b>	0.075
			M12 connector	<b>XS612B4NAM12</b>	0.020
	NC	PNP	Pre-cabled (L = 2 m) (1)	<b>XS612B4PBL2</b>	0.075
			M12 connector	<b>XS612B4PBM12</b>	0.020
		NPN	Pre-cabled (L = 2 m) (1)	<b>XS612B4NBL2</b>	0.075



XS-XT\_515\_CPODA2016166

XS618B4●●M12

### Ø 18, threaded M18 x 1

Sensing distance (Sn) mm	Function	Output	Connection	Reference	Weight (kg)
12	NO	PNP	Pre-cabled (L = 2 m) (1)	<b>XS618B4PAL2</b>	0.100
			M12 connector	<b>XS618B4PAM12</b>	0.040
		NPN	Pre-cabled (L = 2 m) (1)	<b>XS618B4NAL2</b>	0.100
			M12 connector	<b>XS618B4NAM12</b>	0.040
	NC	PNP	Pre-cabled (L = 2 m) (1)	<b>XS618B4PBL2</b>	0.100
			M12 connector	<b>XS618B4PBM12</b>	0.040
		NPN	Pre-cabled (L = 2 m) (1)	<b>XS618B4NBL2</b>	0.100



PF15427B

XS630B5●●M12

### Ø 30, threaded M30 x 1.5

Sensing distance (Sn) mm	Function	Output	Connection	Reference	Weight (kg)
30	NO	PNP	Pre-cabled (L = 2 m) (1)	<b>XS630B5PAL2</b>	0.205
			M12 connector	<b>XS630B5PAM12</b>	0.145
		NPN	Pre-cabled (L = 2 m) (1)	<b>XS630B5NAL2</b>	0.205
	M12 connector		<b>XS630B5NAM12</b>	0.145	
	NC	PNP	M12 connector	<b>XS630B5PBM12</b>	0.145



XS\_515\_CPFJR18004

XSZB1●●

### Accessories (2)

Description	For use with sensors (mm)	Reference	Weight (kg)
Fixing clamps	Ø 8	<b>XSZB108</b>	0.004
	Ø 12	<b>XSZB112</b>	0.006
	Ø 18	<b>XSZB118</b>	0.010
	Ø 30	<b>XSZB130</b>	0.020

(1) For a 5 m long cable replace L2 by L5; for a 10 m long cable replace L2 by L10. Please consult our Customer Care Center for availability.

Example: XS612B4PAL2 becomes XS612B4PAL5 with a 5 m cable.

(2) For more information, see page 120.

# Inductive proximity sensors

XS range, general purpose

Cylindrical, increased range, non-flush mountable

Three-wire DC, solid-state output

Characteristics		XS6●●B4●●●M8	XS6●●B4●●●M12	XS6●●B4●●●L2
Sensor type				
Product certifications	Ø 8	cULus, CE, UKCA		
	Ø 12, 18 and 30	cULus, CE, UKCA, E2		
Connection	Connector	M8	M12	–
	Pre-cabled	–	–	Length: 2 m
Operating zone	Ø 8	mm	0...3.2	
	Ø 12	mm	0...5.6	
	Ø 18	mm	0...9.6	
	Ø 30	mm	0...24	
Differential travel		%	1...15 of effective sensing distance (Sr)	
Degree of protection	Conforming to IEC 60529	IP 65 and IP 67		
	Conforming to DIN 40050	–	IP 69K	IP 65 and IP 68
Storage temperature		°C	-40...+85	
Operating temperature		°C	-25...+70	
Materials	Case	Nickel plated brass (except Ø 8: stainless steel, grade 303)		
	Sensing face	PPS		
	Cable	–	–	PVC 3 x 0.34 mm <sup>2</sup> except for Ø 8: 3 x 0.11 mm <sup>2</sup>
Vibration resistance	Conforming to IEC 60068-2-6	25 gn, amplitude ± 2 mm (f = 10 to 55 Hz)		
Shock resistance	Conforming to IEC 60068-2-27	50 gn, duration 11 ms		
Output state indication			Yellow LED: 4 viewing ports at 90°	Yellow LED: annular
Rated supply voltage		V	--- 12...24 with protection against reverse polarity (Ø 8) --- 12...48 with protection against reverse polarity (Ø 12, 18, 30)	
Voltage limits (including ripple)		V	--- 10...36 (Ø 8) --- 10...58 (Ø 12, 18, 30)	
Insulation class			III	III
Switching capacity		mA	≤ 200 with overload and short-circuit protection	
Voltage drop, closed state		V	≤ 2	
Current consumption, no-load		mA	≤ 10	
Maximum switching frequency	XS608B4●●●● and XS612B4●●●●	Hz	2500	
	XS618B4●●●●	Hz	1000	
	XS630B5●●●●	Hz	500	
Delays	First-up	ms	≤ 10 for Ø 8, Ø 12 and Ø 18; ≤ 15 for Ø 30	
	Response	ms	≤ 0.2 for Ø 8 and Ø 12; ≤ 0.3 for Ø 18; ≤ 0.6 for Ø 30	
	Recovery	ms	≤ 0.2 for Ø 8 and Ø 12; ≤ 0.7 for Ø 18; ≤ 1.4 for Ø 30	

## Wiring schemes

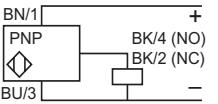
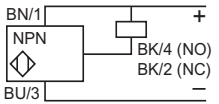
Connector	Pre-cabled	PNP	NPN
M8			
M12			
	BU: Blue BN: Brown BK: Black		

## Setting-up

### Minimum mounting distances (mm)

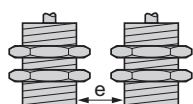

Side by side

Ø 8	$e \geq 24$
Ø 12	$e \geq 48$
Ø 18	$e \geq 72$
Ø 30	$e \geq 300$

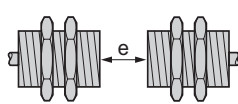

Face to face

$e \geq 40$
$e \geq 84$
$e \geq 144$
$e \geq 300$

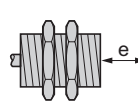

Facing a metal object

$e \geq 12$
$e \geq 21$
$e \geq 36$
$e \geq 90$

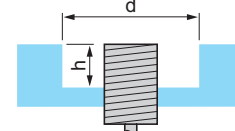

Mounted in a metal support

$d \geq 24, h \geq 8$
$d \geq 36, h \geq 12$
$d \geq 54, h \geq 18$
$d \geq 90, h \geq 35$

## Dimensions

	XS6	Pre-cabled (mm)			M8 Connector (mm)			M12 Connector (mm)		
		a	b	c	a	b	c	a	b	c
Ø 8		51	38	4	58	39	4	61	36	4
Ø 12		54	42	5	–	–	–	66	42	5
Ø 18		60	44	8	–	–	–	72	44	8
Ø 30		66	41	13	–	–	–	74	41	13

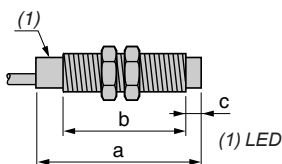

# Inductive proximity sensors

XS range, general purpose

Cylindrical, increased range, non-flush mountable

Three-wire DC, solid-state output

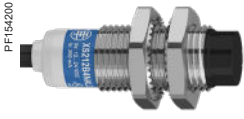

XS212B4●●L●



XS218B4●●M12



XSZB1●●

## Sensors, 3-wire 12-24 V, short case model

### Ø 12, threaded M12 x 1

Sensing distance (Sn) mm	Function	Output	Connection	Reference	Weight (kg)
8	NO	PNP	Pre-cabled (L = 2 m)	XS212B4PAL2	0.086
			Pre-cabled (L = 5 m)	XS212B4PAL5	0.160
			M12 connector	XS212B4PAM12	0.032
	NPN	PNP	Pre-cabled (L = 2 m)	XS212B4NAL2	0.086
			M12 connector	XS212B4NAM12	0.032
	NC	PNP	Pre-cabled (L = 2 m)	XS212B4PBL2	0.086
M12 connector			XS212B4PBM12	0.032	
		NPN	Pre-cabled (L = 2 m)	XS212B4NBL2	0.086

### Ø 18, threaded M18 x 1

Sensing distance (Sn) mm	Function	Output	Connection	Reference	Weight (kg)
16	NO	PNP	Pre-cabled (L = 2 m)	XS218B4PAL2	0.105
			M12 connector	XS218B4PAM12	0.052
			NPN	Pre-cabled (L = 2 m)	XS218B4NAL2
	NPN	PNP	M12 connector	XS218B4NAM12	0.052
			Pre-cabled (L = 2 m)	XS218B4PBL2	0.105
			NPN	M12 connector	XS218B4PBM12

## Accessories (1)

Description	For use with sensors (mm)	Reference	Weight (kg)
Fixing clamps	Ø 12	XSZB112	0.006
	Ø 18	XSZB118	0.010

(1) For further information, see page 120.

Characteristics			XS21●B4●●M12	XS21●B4●●L●
Sensor type			cULus, CE, UKCA, E2	
Product certifications			M12	
Connection			Pre-cabled	
Operating zone			Length: 2 or 5 m	
Differential travel			%	
Degree of protection			%	
Storage temperature			°C	
Operating temperature			°C	
Materials			Case	
			Sensing face	
			Cable	
Vibration resistance			Conforming to IEC 60068-2-6	
Shock resistance			Conforming to IEC 60068-2-27	
Output state indication			Yellow LED, 4 viewing ports at 90°	
Rated supply voltage			V	
Voltage limits (including ripple)			V	
Insulation class			□ □	
Switching capacity			mA	
Voltage drop, closed state			V	
Current consumption, no-load			mA	
Maximum switching frequency			Hz	
Delays			ms	

## Wiring schemes

Connector	Pre-cabled	PNP	NPN
M12 4 3 1 2	BU: Blue BN: Brown BK: Black		

## Setting-up

### Minimum mounting distances (mm)

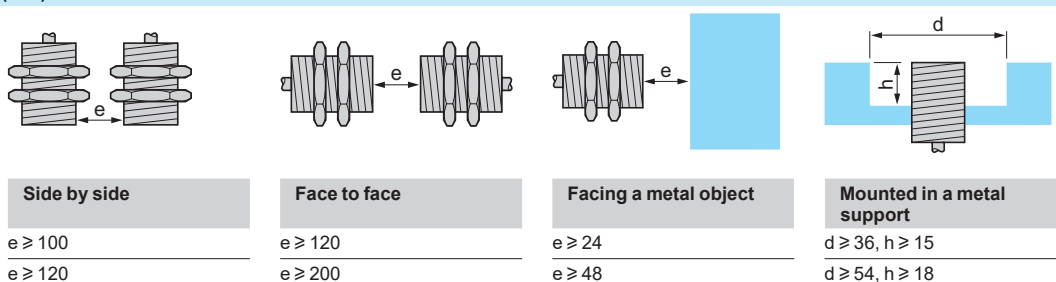

## Dimensions

	Pre-cabled (mm)			M12 connector (mm)		
	a	b	c	a	b	c
Ø 12	37	20	5	51	26	5
Ø 18	41	21	8	51	21	8

(1) LED

## Inductive proximity sensors

XS range, general purpose

Cylindrical, increased range, non flush mountable

Two-wire AC or DC

103189



XS618B4MAL2

### Sensors, 2-wire $\approx$ 24... 240 V, long case model

#### Ø 18, threaded M18 x 1

Sensing distance (Sn) mm	Function	Connection	Reference	Weight (kg)
12	NO	Pre-cabled (L = 2 m) (1)	<b>XS618B4MAL2</b>	0.120
		1/2"-20 UNF connector	<b>XS618B4MAU20</b>	0.060
	NC	Pre-cabled (L = 2 m) (1)	<b>XS618B4MBL2</b>	0.120
		1/2"-20 UNF connector	<b>XS618B4MBU20</b>	0.060

PF154217B



XS630B4MAL20

#### Ø 30, threaded M30 x 1.5

Sensing distance (Sn) mm	Function	Connection	Reference	Weight (kg)
22	NO	Pre-cabled (L = 2 m) (1)	<b>XS630B4MAL2</b>	0.205
		1/2"-20 UNF connector	<b>XS630B4MAU20</b>	0.145
	NC	Pre-cabled (L = 2 m) (1)	<b>XS630B4MBL2</b>	0.205

XS\_515\_CPF-IR16004



XSZB118

### Accessories (2)

Description	For use with sensors (mm)	Reference	Weight (kg)
Fixing clamps	Ø 18	<b>XSZB118</b>	0.010
	Ø 30	<b>XSZB130</b>	0.020

(1) For a 5 m cable replace L2 by L5; for a 10 m cable replace L2 by L10.  
Example: XS618B4MAL2 becomes **XS618B4MAL5** with a 5 m cable.

(2) For more information, see page 120.

Characteristics			XS6●●B4M●U20	XS6●●B4M●L2
Sensor type				
Product certifications			cULus, CE, UKCA	
Connection	Connector		1/2"-20 UNF	–
	1/2"-20 UNF Pre-cabled		–	Length: 2 m
Operating zone	∅ 18	mm	0...9.6	
	∅ 30	mm	0...17.6	
Differential travel		%	1...15 of effective sensing distance (Sr)	
Degree of protection	Conforming to IEC 60529		IP 65 and IP 67	IP 65 and IP 68
Storage temperature		°C	-40...+85	
Operating temperature		°C	-25...+70	
Materials	Case		Nickel plated brass	
	Sensing face		PPS	
	Cable		–	PvR 2 x 0.34 mm <sup>2</sup>
Vibration resistance	Conforming to IEC 60068-2-6		25 gn, amplitude ± 2 mm (f = 10 to 55 Hz)	
Shock resistance	Conforming to IEC 60068-2-27		50 gn, duration 11 ms	
Output state indication			Yellow LED: 4 viewing ports at 90°	Yellow LED: annular
Rated supply voltage		V	~ or --- 24...240 (~ 50/60 Hz)	
Voltage limits (including ripple)		V	~ or --- 20...264	
Insulation class			I	I
Switching capacity		mA	~ 5...300 or --- 5...200 (1)	
Voltage drop, closed state		V	≤ 5.5	
Residual current, open state		mA	≤ 0.8	
Maximum switching frequency	XS618B4M●●●	Hz	~ 25 or --- 1000	
	XS630B4M●●●	Hz	~ 25 or --- 300	
Delays	First-up	ms	≤ 30 XS618B4M●●● and XS630B4M●●●	
	Response	ms	≤ 0.5	
	Recovery	ms	≤ 0.5 XS618B4M●●●, ≤ 2 XS630B4M●●●	

(1) It is essential to connect a 0.4 A "quick-blow" fuse in series with the load.

## Wiring schemes

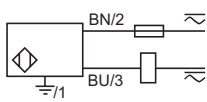
Connector	Pre-cabled	2-wire ~ or ---
1/2"-20 UNF	BU: Blue BN: Brown	NO or NC output
		
1 2 3 ~: 2 ⊕: 1 ~: 3		⊕: on connector models only

## Setting-up

### Minimum mounting distances (mm)

	Side by side	Face to face	Facing a metal object	Mounted in a metal support
∅ 18	e ≥ 72	e ≥ 144	e ≥ 36	d ≥ 54, h ≥ 18
∅ 30	e ≥ 120	e ≥ 264	e ≥ 66	d ≥ 90, h ≥ 30

## Dimensions

	Pre-cabled (mm)			Connector (mm)		
	a	b	c	a	b	c
∅ 18	60	44	8	72	44	8
∅ 30	63	41	13	74	41	13

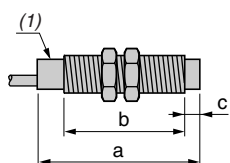

(1) LED

# Inductive proximity sensors

XS range, general purpose, standard range

Flat format, flush mountable

Two-wire DC

Three-wire DC, solid-state output



XS7J1A1●●L2



XS7F1A1●●L2



XS7F1A1●●L01M8

### Flat, 8 x 22 x 8 mm format <sup>(1) (2)</sup>

Three-wire ---						
Sensing distance (Sn) mm	Function	Output	Connection	Reference	Weight (kg)	
2.5	NO	PNP	Pre-cabled (L = 2 m) <sup>(3)</sup>	<b>XS7J1A1PAL2</b>	0.060	
			Remote M8 connector on 0.15 m flying lead	<b>XS7J1A1PAL01M8</b>	0.040	
	NPN	PNP	Pre-cabled (L = 2 m) <sup>(3)</sup>	<b>XS7J1A1NAL2</b>	0.060	
			Remote M8 connector on 0.15 m flying lead	<b>XS7J1A1NAL01M8</b>	0.040	
	NC	PNP	Pre-cabled (L = 2 m) <sup>(3)</sup>	<b>XS7J1A1PBL2</b>	0.060	
			Remote M8 connector on 0.15 m flying lead	<b>XS7J1A1PBL01M8</b>	0.040	
		NPN	Pre-cabled (L = 2 m) <sup>(3)</sup>	<b>XS7J1A1NBL2</b>	0.060	

Two-wire ---						
Sensing distance (Sn) mm	Function	Output	Connection	Reference	Weight (kg)	
2.5	NO		Pre-cabled (L = 2 m) <sup>(3)</sup>	<b>XS7J1A1DAL2</b>	0.050	

### Flat, 15 x 32 x 8 mm format <sup>(1)</sup>

Three-wire ---						
Sensing distance (Sn) mm	Function	Output	Connection	Reference	Weight (kg)	
5	NO	PNP	Pre-cabled (L = 2 m) <sup>(3)</sup>	<b>XS7F1A1PAL2</b>	0.065	
			Remote M8 connector on 0.15 m flying lead	<b>XS7F1A1PAL01M8</b>	0.045	
	NPN	PNP	Pre-cabled (L = 2 m) <sup>(3)</sup>	<b>XS7F1A1NAL2</b>	0.065	
			Remote M8 connector on 0.15 m flying lead	<b>XS7F1A1NAL01M8</b>	0.045	
	NC	PNP	Pre-cabled (L = 2 m) <sup>(3)</sup>	<b>XS7F1A1PBL2</b>	0.065	
			Remote M8 connector on 0.15 m flying lead	<b>XS7F1A1PBL01M8</b>	0.045	
		NPN	Pre-cabled (L = 2 m) <sup>(3)</sup>	<b>XS7F1A1NBL2</b>	0.065	

Two-wire ---						
Sensing distance (Sn) mm	Function	Output	Connection	Reference	Weight (kg)	
5	NO		Pre-cabled (L = 2 m) <sup>(3)</sup>	<b>XS7F1A1DAL2</b>	0.055	
	NC		Pre-cabled (L = 2 m) <sup>(3)</sup>	<b>XS7F1A1DBL2</b>	0.055	
			Remote M8 connector on 0.15 m flying lead	<b>XS7F1A1DBL01M8</b>	0.045	

(1) For accessories, see page 120.

(2) Sensors **XS7J** include a fixing clamp with screw.

(3) For a 5 m long cable replace L2 by **L5**; for a 10 m long cable replace L2 by **L10**.  
Example: **XS7J1A1PAL2** becomes **XS7J1A1PAL5** with a 5 m long cable.

# Inductive proximity sensors

XS range, general purpose, standard range

Flat format, flush mountable

Two-wire DC

Three-wire DC, solid-state output

Characteristics		XS7J●●●●●L01M8	XS7F●●●●●L01M8	XS7J●●●●●L2, XS7F●●●●●L2
Sensor type		CE	cULus, CE, UKCA	
Product certifications				
Connection	Connector	Remote M8 connector on 0.15 m flying lead		–
	Pre-cabled	–		Length: 2 m
Operating zone	XS7J	mm	0...2	
	XS7F	mm	0...4	
Differential travel		%	1...15 of effective sensing distance (Sr)	
Degree of protection	Conforming to IEC 60529		IP 67 (XS7J), IP 68 (XS7F)	
Storage temperature		°C	-40...+85	
Operating temperature		°C	-25...+70	
Materials	Case		PBT	
	Cable		PvR 3 x 0.11 mm <sup>2</sup> or 2 x 0.11 mm <sup>2</sup> (XS7F: 2 or 3 x 0.34 mm <sup>2</sup> )	
Vibration resistance	Conforming to IEC 60068-2-6		25 gn, amplitude ± 2 mm (f = 10 to 55 Hz)	
Shock resistance	Conforming to IEC 60068-2-27		50 gn, duration 11 ms	
Output state indication			Yellow LED	
Rated supply voltage		V	12...24 with protection against reverse polarity	
Voltage limits (including ripple)		V	10...36	
Insulation class			III	III
Current consumption, no-load	3-wire	mA	≤ 10	
Residual current, open state	2-wire	mA	≤ 0.5	
Switching capacity	3-wire	mA	100 with overload and short-circuit protection	
	2-wire	mA	1.5...100 with overload and short-circuit protection	
Voltage drop, closed state	3-wire	V	≤ 2	
	2-wire	V	≤ 4	
Maximum switching frequency	3-wire	kHz	2	
	2-wire	kHz	4 for XS7J, 5 for XS7F	
Delays	First-up	ms	Three-wire: 5	
		ms	Two-wire: 10 XS7J, 5 XS7F	
	Response	ms	Three-wire: 0,1	
		ms	Two-wire: 0,5 XS7J, 5 XS7F	
	Recovery	ms	Three-wire: 0,1	
		ms	Two-wire: 1 XS7J, 5 XS7F	

## Wiring schemes

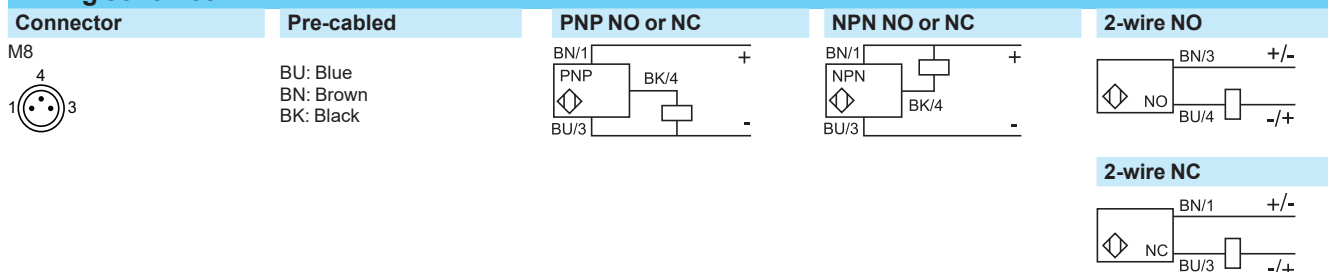

## Setting-up

### Minimum mounting distances (mm)

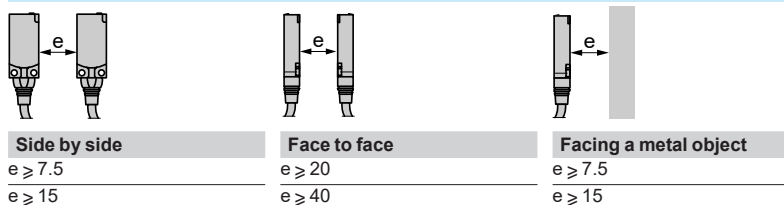

## Dimensions

### XS7F

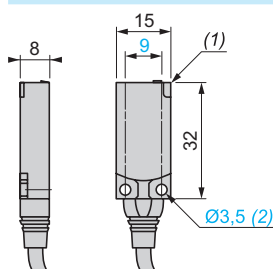

### XS7J

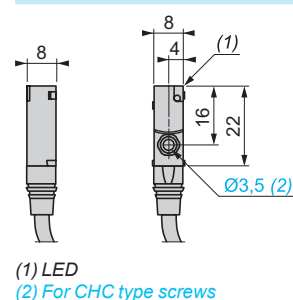

# Inductive proximity sensors

XS range, general purpose, standard range

Flat format, flush mountable

Two-wire DC

Three-wire DC, solid-state output



XS7E1A1●●L2



XS7E1A1●●M8



XS7C1A1●●L2



XS7●1A1●L0●M12



XS7C1A1●●M8



XS7D1A1●●L2



XS7D1A1●●M12



XS7D1A1●●L2DIN



XS7D1A1●●M12DIN

Sens. dist. (Sn) mm	Function	Output	Connection	Reference	Weight (kg)
---------------------	----------	--------	------------	-----------	-------------

### Flat, 26 x 26 x 13 mm format (1)

#### Three-wire ---

10	NO	PNP	Pre-cabled (L = 2 m) (3)	<b>XS7E1A1PAL2</b>	0.075
			M8 connector	<b>XS7E1A1PAM8</b>	0.040
			Remote M12 connector	<b>XS7E1A1PAL01M12</b>	0.040
	NC	PNP	Pre-cabled (L = 2 m) (3)	<b>XS7E1A1PBL2</b>	0.075
			M8 connector	<b>XS7E1A1PBM8</b>	0.040
			Remote M12 connector	<b>XS7E1A1PBL01M12</b>	0.040
		NPN	Pre-cabled (L = 2 m) (3)	<b>XS7E1A1NBL2</b>	0.075

#### Two-wire ---

10	NO	Pre-cabled (L = 2 m) (3)	<b>XS7E1A1DAL2</b>	0.070
		Remote M12 connector	<b>XS7E1A1DAL01M12</b>	0.040
		NO terminals 1 and 4 (2)	Remote M12 connector	<b>XS7E1A1CAL01M12</b>

### Flat, 40 x 40 x 15 mm format (1)

#### Three-wire ---

15	NO	PNP	Pre-cabled (L = 2 m) (3)	<b>XS7C1A1PAL2</b>	0.095
			M8 connector	<b>XS7C1A1PAM8</b>	0.060
			Remote M12 connector	<b>XS7C1A1PAL01M12</b>	0.060
	NC	PNP	Pre-cabled (L = 2 m) (3)	<b>XS7C1A1PBL2</b>	0.095
			M8 connector	<b>XS7C1A1PBM8</b>	0.060
			Remote M12 connector	<b>XS7C1A1PBL01M12</b>	0.060
		NPN	Pre-cabled (L = 2 m) (3)	<b>XS7C1A1NBL2</b>	0.095
			M8 connector	<b>XS7C1A1NBM8</b>	0.060

#### Two-wire ---

15	NO	Pre-cabled (L = 2 m) (3)	<b>XS7C1A1DAL2</b>	0.090
		M8 connector	<b>XS7C1A1DAM8</b>	0.060
		NC	Remote M12 connector	<b>XS7C1A1DBL01M12</b>

### Flat, 80 x 80 x 26 mm format (1)

#### Three-wire ---

40	NO	PNP	Pre-cabled (L = 2 m) (3)	<b>XS7D1A1PAL2 (4)</b>	0.340	
			M12 connector	<b>XS7D1A1PAM12 (4)</b>	0.290	
			NPN	Pre-cabled (L = 2 m) (3)	<b>XS7D1A1NAL2 (4)</b>	0.340
			NC	M12 connector	<b>XS7D1A1PBM12 (4)</b>	0.290

#### Two-wire ---

40	NO	Pre-cabled (L = 2 m) (3)	<b>XS7D1A1DAL2 (4)</b>	0.340
		M12 connector	<b>XS7D1A1DAM12 (4)</b>	0.290
		NC	Pre-cabled (L = 2 m) (3)	<b>XS7D1A1DBL2 (4)</b>

(1) For accessories, see page 120.

(2) The NO output is connected to terminals 1 and 4 of the M12 connector.

(3) For a 5 m long cable replace L2 by L5; for a 10 m long cable replace L2 by L10.

Example: **S7 J1A1PAL2** becomes **XS7 J1A1PAL5** with a 5 m long cable.

(4) For clipping onto 35 mm omega rail or 80 x 80 x 40 mm format, add DIN to the end of the reference. Example: **XS7D1A1PAL2** becomes **XS7D1A1PAL2DIN**.

# Inductive proximity sensors

XS range, general purpose, standard range

Flat format, flush mountable

Two-wire DC

Three-wire DC, solid-state output

Characteristics		XS7E●●●●●M8, XS7C●●●●●M8, XS7D●●●●●M12	XS7E●●●●●L01M12, XS7C●●●●●L01M12	XS7E●●●●●L2, XS7C●●●●●L2, XS7D●●●●●L2
Sensor type				
Product certifications		cULus, CE, UKCA, ECOLAB		
Connection	Connector	M8 except M12 on XS7D●●●●●M12	M12 on 0.15 m flying lead for XS7●●●●●L01M12	–
	Pre-cabled	–	–	Length: 2 m
Operating zone	XS7E	mm	0...8	
	XS7C	mm	0...12	
	XS7D	mm	0...32	
Differential travel		%	1...15 of effective sensing distance (Sr)	
Degree of protection		Conforming to IEC 60529	IP 67	IP 68
Storage temperature		°C	-40...+85	
Operating temperature		°C	-25...+70	
Materials	Case	PBT		
	Cable	–	PvR 3 x 0.34 mm <sup>2</sup> or 2 x 0.34 mm <sup>2</sup>	
Vibration resistance		Conforming to IEC 60068-2-6	25 gn, amplitude ± 2 mm (f = 10 to 55 Hz)	
Shock resistance		Conforming to IEC 60068-2-27	50 gn, duration 11 ms	
Output state indication		Yellow LED		
Rated supply voltage		V	12...24 with protection against reverse polarity	
Voltage limits (including ripple)		V	10...36	
Insulation class		M8 connector: III M12 connector: □	□	□
Current consumption, no-load		3-wire	mA	≤ 10
Residual current, open state		2-wire	mA	≤ 0.5
Switching capacity	3-wire	mA	≤ 100 with overload and short-circuit protection	
	2-wire	mA	1.5...100 with overload and short-circuit protection	
Voltage drop, closed state	3-wire	V	≤ 2	
	2-wire	V	≤ 4	
Maximum switching frequency	XS7E, XS7C	kHz	1	
	XS7D	Hz	100	
Delays	First-up	3-wire	ms	10 XS7E and XS7C, 30 XS7D
		2-wire	ms	5 XS7E and XS7D, 10 XS7D
	Response	3-wire	ms	2 XS7E and XS7C, 5 XS7D
		2-wire	ms	0,3 XS7E and XS7D, 10 XS7D
	Recovery	3-wire	ms	6 XS7E, 5 XS7C, 35 XS7D
		2-wire	ms	0,7 XS7E and XS7D, 10 XS7D

## Wiring schemes

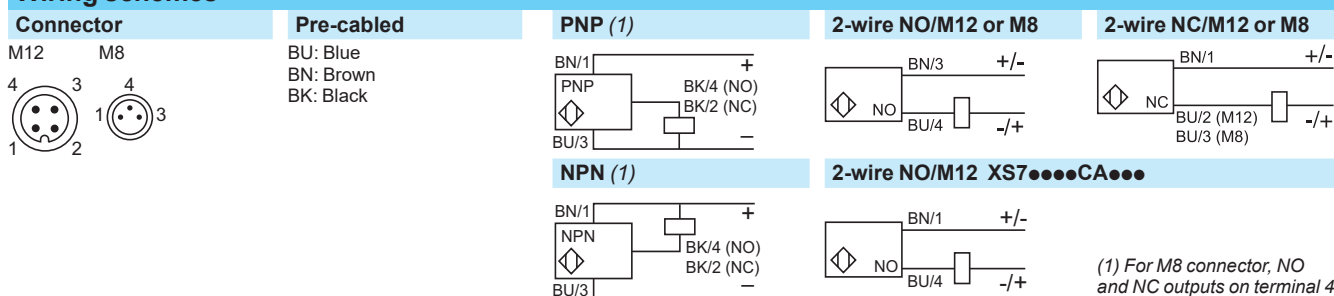

## Setting-up

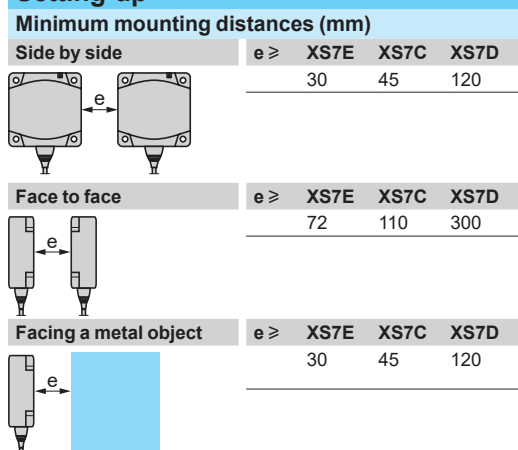

## Dimensions

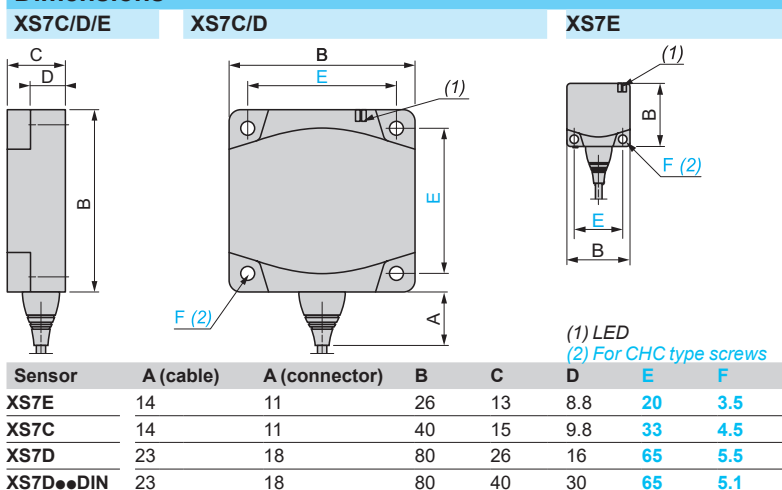

# Inductive proximity sensors

XS range, general purpose with increased range  
Flat, flush mountable using teach mode (1)  
Two-wire AC or DC  
Three-wire DC, solid-state output



### Flat, 26 x 26 x 13 mm format (2)

Sensing distance (Sn) mm	Function	Output	Connection	Reference	Weight (kg)
15	NO	PNP	Pre-cabled (L = 2 m) (3)	XS8E1A1PAL2	0.075
			M8 connector	XS8E1A1PAM8	0.040
			Remote M12 connector	XS8E1A1PAL01M12	0.040
	NC	PNP	Pre-cabled (L = 2 m) (3)	XS8E1A1NAL2	0.075
			M8 connector	XS8E1A1PBM8	0.040
			NPN	Pre-cabled (L = 2 m) (3)	XS8E1A1NBL2
			M8 connector	XS8E1A1NBM8	0.040

### Two-wire ~ or --- unprotected (4)

15	NO	-	Pre-cabled (L = 2 m) (3)	XS8E1A1MAL2	0.070
			Remote 1/2"-20UNF connector	XS8E1A1MAL01U20	0.040
NC	-	-	Pre-cabled (L = 2 m) (3)	XS8E1A1MBL2	0.070
			Remote 1/2"-20UNF connector	XS8E1A1MBL01U20	0.040

### Flat, 40 x 40 x 15 mm format (2)

Sensing distance (Sn) mm	Function	Output	Connection	Reference	Weight (kg)
25	NO	PNP	Pre-cabled (L = 2 m) (3)	XS8C1A1PAL2	0.095
			M8 connector	XS8C1A1PAM8	0.060
			Remote M12 connector	XS8C1A1PAL01M12	0.060
	NC	PNP	Pre-cabled (L = 2 m) (3)	XS8C1A1NAL2	0.095
			M8 connector	XS8C1A1PBM8	0.060
			NPN	Pre-cabled (L = 2 m) (3)	XS8C1A1NBL2
			M8 connector	XS8C1A1NBM8	0.060

### Two-wire ~ or --- unprotected (4)

25	NO	-	Pre-cabled (L = 2 m) (3)	XS8C1A1MAL2	0.090
			Remote 1/2"-20UNF connector	XS8C1A1MAL01U20	0.060
NC	-	-	Pre-cabled (L = 2 m) (3)	XS8C1A1MBL2	0.090
			Remote 1/2"-20UNF connector	XS8C1A1MBL01U20	0.060

### Flat, 80 x 80 x 26 mm format (2)

Sensing distance (Sn) mm	Function	Output	Connection	Reference	Weight (kg)
60	NO	PNP	Pre-cabled (L = 2 m) (3)	XS8D1A1PAL2 (5)	0.390
			M12 connector	XS8D1A1PAM12 (5)	0.340
			NPN	Pre-cabled (L = 2 m) (3)	XS8D1A1NAL2 (5)
	NC	PNP	Pre-cabled (L = 2 m) (3)	XS8D1A1PBL2 (5)	0.390
			M12 connector	XS8D1A1PBM12 (5)	0.340
			NPN	Pre-cabled (L = 2 m) (3)	XS8D1A1NBL2 (5)

### Two-wire ~ or --- unprotected (4)

60	NO	-	Pre-cabled (L = 2 m) (3)	XS8D1A1MAL2 (5)	0.390
			1/2"-20UNF connector	XS8D1A1MAU20 (5)	0.340
NC	-	-	Pre-cabled (L = 2 m) (3)	XS8D1A1MBL2 (5)	0.390
			1/2"-20UNF connector	XS8D1A1MBU20 (5)	0.340

(1) For further information on flush or non-flush mountable sensors using teach mode, see page 22.

(2) For accessories, see page 120.

(3) For a 5 m long cable replace L2 by L5; for a 10 m long cable replace L2 by L10.

(4) It is essential to connect a 0.4 A "quick-blow" fuse in series with the load.

(5) For clipping onto 35 mm omega rail or 80 x 80 x 40 mm format, add DIN to the end of the reference. Example: XS8D1A1PAL2DIN.

# Inductive proximity sensors

XS range, general purpose with increased range

Flat, flush mountable using teach mode (1)

Two-wire AC or DC

Three-wire DC, solid-state output

Characteristics		XS8E●●●●M8, XS8C●●●●M8, XS8D●●●●M12, XS8D●●●●U20	XS8E●●●●L01M12, XS8E●●●●L01U20, XS8C●●●●L01M12, XS8C●●●●L01U20	XS8E●●●●L2, XS8C●●●●L2, XS8D●●●●L2
Sensor type				
Product certifications		cULus, CE, UKCA, ECOLAB		
Connection	Connector	M8 except XS8●●●●M12: M12 XS8●●●●U20: 1/2"-20UNF	Remote on 0.15 m flying lead XS8●●●●L01M12: M12 XS8●●●●L01U20: 1/2"-20UNF	–
	Pre-cabled	–	–	Length: 2 m
Sensing distance and adjustment zone	XS8E	Nominal sensing dist. Sn	mm 0...15 not flush mounted / 0...10 flush mounted	
		Fine adjustment zone	mm 5...15 not flush mounted / 5...10 flush mounted	
	XS8C	Nominal sensing dist. Sn	mm 0...25 not flush mounted / 0...15 flush mounted	
		Fine adjustment zone	mm 8...25 not flush mounted / 8...15 flush mounted	
	XS8D	Nominal sensing dist. Sn	mm 0...60 not flush mounted / 0...40 flush mounted	
		Fine adjustment zone	mm 20...60 not flush mounted / 20...40 flush mounted	
Differential travel		% 1...15 of effective sensing distance (Sr)		
Degree of protection	Conforming to IEC 60529	IP 67		IP 68
Storage temperature		°C -40...+85		
Operating temperature		°C -25...+70		
Materials	Case	PBT		
	Cable	–	PvR 3 x 0.34 mm <sup>2</sup> ≍ and PvR 2 x 0.34 mm <sup>2</sup> ≍	
Vibration resistance	Conforming to IEC 60068-2-6	25 gn, amplitude ± 2 mm (f = 10 to 55 Hz)		
Shock resistance	Conforming to IEC 60068-2-27	50 gn, duration 11 ms		
Indicators	Output state	Yellow LED		
	Supply on and teach mode	Green LED		
Rated supply voltage	3-wire	V 12...24 with protection against reverse polarity		
	2-wire	V ~ or ≍ 24...240 (~ 50/60 Hz)		
Voltage limits (including ripple)	3-wire	V 10...36		
	2-wire	V ~ or ≍ 20...264		
Insulation class		II, except M8 connector: III		
Current consumption, no-load	3-wire	mA ≤ 10		
Residual current, open state	2-wire	mA ≤ 1.5		
Switching capacity	3-wire	mA ≤ 100 XS8E, ≤ 200 XS8C and XS8D, with overload and short-circuit protection		
	2-wire	mA 5...200 ≍ XS8E, 5...300 ~ XS8C and XS8D, 5...200 ≍ XS8C and XS8D		
Voltage drop, closed state	3-wire	V ≤ 2		
	2-wire	V ≤ 5.5		
Maximum switching frequency		Hz 2000 XS8E, 1000 XS8C, 150 XS8D		
Delays	First-up	ms ≤ 10 XS8E, XS8C and XS8D (3-wire), ≤ 10 XS8E and XS8C, ≤ 15 XS8D (2-wire)		
	Response	ms ≤ 0.3		
	Recovery	ms ≤ 0.8 XS8E and XS8C, ≤ 6 XS8D		

## Wiring schemes

Connector	Pre-cabled	PNP/M12 or M8	NPN/M12 or M8	2-wire 1/2"-20UNF
M8 M12 1/2"-20UNF 	BU: Blue BN: Brown BK: Black			
For M8 connector, NO and NC outputs on terminal 4				

## Setting-up

### Minimum mounting distances (mm)

Side by side	e ≥	XS8E	XS8C	XS8D
	Flush mounted	40	60	200
	Not flush mounted	150	125	600
Face to face	e ≥	XS8E	XS8C	XS8D
	Flush mounted	80	120	400
	Not flush mounted	300	250	not recommended
Facing a metal object	e ≥	XS8E	XS8C	XS8D
		10	15	40

## Dimensions

Sensor	A (cable)	A (connector)	B	C	D	E	F	G	H
XS8E	14	11	26	13	8.8	20	3.5	6.8	6.6
XS8C	14	11	40	15	9.8	33	4.5	8.3	13.6
XS8D	23	18	80	26	16	65	5.5	8.5	37.8
XS8D●●DIN	23	18	80	40	30	65	5.1	22.5	37.8

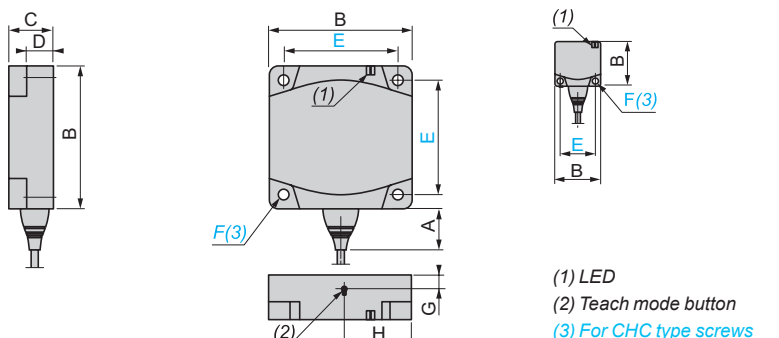

# Inductive proximity sensors

XS range, general purpose

Cubic case, 40 x 40 x 70 mm,

M12 or 1/2"-20UNF connector

5-position turret head

Sensor type	Flush mountable in metal	Non-flush mountable in metal
-------------	--------------------------	------------------------------



Nominal sensing distance (Sn)	mm	15	20	40
-------------------------------	----	----	----	----

## References

4-wire ---	PNP NO+NC	—	XS8C2A1PCM12	XS8C2A4PCM12	—
	NPN NO+NC	—	XS8C2A1NCM12	XS8C2A4NCM12	—
3-wire ---	PNP NO	XS7C2A1PAM12	—	—	—
	NPN NO	XS7C2A1NAM12	—	—	—
	PNP NC	XS7C2A1PBM12	—	—	—
	NPN NC	XS7C2A1NBM12	—	—	—
2-wire ---	NO	XS7C2A1DAM12	XS8C2A1DAM12	XS8C2A4DAM12	XS8C2A4CAM12 (3)
	NC	XS7C2A1DBM12	—	—	—
2-wire (~/---) unprotected (1)	NO	—	XS8C2A1MAU20	XS8C2A4MAU20	—
	NC	—	XS8C2A1MBU20	XS8C2A4MBU20	—
Weight	kg	0.149	0.149	0.149	0.149

## Characteristics

Operating zone	mm	0...12	0...16	0...32
Product certifications	cULus, CÉ, UKCA, E2 ( 3-wire and 4-wire)			
Conformity to standards	IEC 60947-5-2			
Connection	M12 connector for --- versions 1/2"-20UNF connector for ~/--- versions			
Differential travel	%	3...15 of Sr		
Degree of protection	Conforming to IEC 60529 and DIN 40050	IP 65, IP 67 and IP 69K		
Temperature	Storage	°C - 40...+ 85		
	Operation (2)	°C - 25...+ 70		
Material	Case: PBT			
Vibration resistance	Conforming to IEC 60068-2-6	25 gn, amplitude ± 2 mm (f = 10...55 Hz)		
Shock resistance	Conforming to IEC 60068-2-27	50 gn for 11 ms		
Indicators	Output state	Yellow LED		
	Power on	Green LED, for 4-wire ---, 3-wire --- and 2-wire ~/--- versions		
Rated supply voltage	4-wire ---	V	12...48 with protection against reverse polarity	
	3-wire ---	V	12...24 with protection against reverse polarity	
	2-wire ---	V	12...48 with protection against reverse polarity	
	2-wire ~/---	V	24...240 (~ 50/60 Hz)	
Voltage limits (including ripple)	4-wire ---	V	10...58	
	3-wire ---	V	10...36	
	2-wire ---	V	10...58	
	2-wire ~/---	V	20...264	
Insulation class	---		II	
	~/---		I	
Current consumption, no-load	3-wire and 4-wire ---	mA	< 15	
Residual current, open state	2-wire ---	mA	< 0.6	
	2-wire ~/---	mA	1.5	
Switching capacity	3-wire and 4-wire ---	mA	< 200 with overload and short-circuit protection	
	2-wire ---	mA	< 100 with overload and short-circuit protection	
	2-wire ~/---	mA	~: 5...300 (1) ---: 5...200 mA (1)	
Voltage drop, closed state	3-wire and 4-wire ---	V	< 2	
	2-wire ---	V	< 4.2	
	2-wire ---/~	V	< 5.5	
Maximum switching frequency		kHz	Flush mountable: --- 300, ~ 25 Non-flush mountable: --- 150, ~ 25	
Delays	First-up	ms	7 (3-wire and 4-wire ---), 20 (2-wire --- and 2-wire ---/~)	
	Response	ms	Flush mountable: ≤ 1.2. Non-flush mountable: ≤ 1.4	
	Recovery	ms	Flush mountable: ≤ 1.8. Non-flush mountable: ≤ 3.5	

(1) Sensor must be protected by a 0.4 A quick-blow fuse connected in series with the load.

(2) Sensors are available for very low temperatures (suffix TF: - 40°C, + 70°C) or very high temperatures (suffix TT: - 25°C, + 85°C). Please consult our Customer Care Centre.

(3) NO terminal 1 & 4 - the NO output is connected to terminal 1 and 4 of M12 connectors.

# Inductive proximity sensors

XS range, general purpose

Cubic case, 40 x 40 x 70 mm,

M12 or 1/2"-20UNF connector

5-position turret head

## Setting-up precautions

### Minimum mounting distances (mm)

		Side by side	Face to face	Facing a metal object
Sensors flush mountable in metal	XS7C2A1●●	$e \geq 60$	$e \geq 120$	$e \geq 45$
	XS8C2A1●●	$e \geq 80$	$e \geq 160$	$e \geq 60$
Sensors non-flush mountable in metal	XS8C2A4●●	$e \geq 160$	$e \geq 320$	$e \geq 120$

## Wiring schemes

### 4-wire $\overline{\text{NPN}}$ , NO + NC outputs

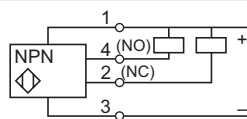
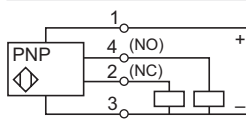

### 3-wire, PNP

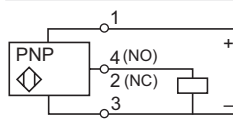

### 3-wire, NPN

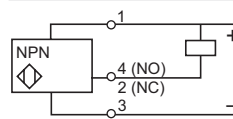

### 2-wire, 1/2"-20UNF

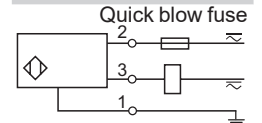

### 2-wire $\overline{\text{NPN}}$ , NO output (M12 connector)

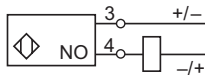

### 2-wire $\overline{\text{NPN}}$ , NC output (M12 connector)

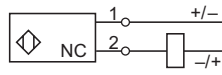

### M12 connector

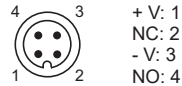

### 1/2"-20UNF connector



### 2-wire $\overline{\text{NPN}}$ , NO output

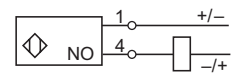

## Accessory references

Description	Type	Length (m)	Reference	Weight (kg)
Pre-wired M12 connectors Female, 4-pin, zinc die-cast, nickel plated clamping ring	Straight	2	XZCP1141L2	0.090
		5	XZCP1141L5	0.190
		10	XZCP1141L10	0.370
	Elbowed	2	XZCP1241L2	0.090
		5	XZCP1241L5	0.190
		10	XZCP1241L10	0.370
Pre-wired 1/2"-20UNF connectors Female, 3-pin, zinc die-cast, nickel plated clamping ring	Straight	5	XZCP1865L5	0.180
		10	XZCP1865L10	0.350
		10	XZCP1865L10	0.350
	Elbowed	5	XZCP1965L5	0.180
		10	XZCP1965L10	0.350
		10	XZCP1965L10	0.350

## Dimensions

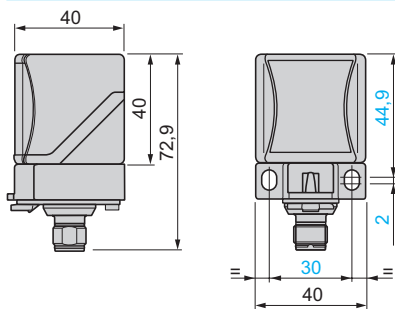

## Head positions

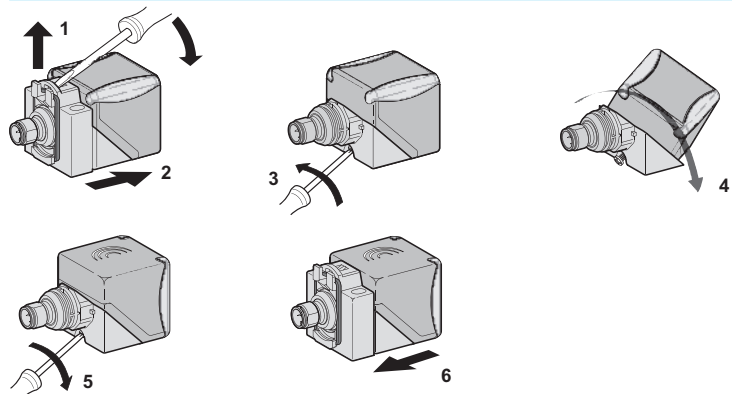

# Inductive proximity sensors

XS range, general purpose

Plastic case, 40 x 40 x 117 mm, plug-in

5-position turret head

Sensor type	Flush mountable in metal	Non-flush mountable in metal
-------------	--------------------------	------------------------------



Nominal sensing distance (Sn)	mm	15	20	40
Connection type		–	–	Cable entry
				M12 connector

## References

4-wire $\overline{\text{---}}$	PNP	NO+NC	–	XS8C4A1PCP20	XS8C4A4PCP20	XS8C4A4PCM12
	NPN	NO+NC	–	XS8C4A1NCP20	XS8C4A4NCP20	
2-wire $\overline{\text{---}}$	NO or NC programmable		XS7C4A1DPP20	XS8C4A1DPP20	XS8C4A4DPP20	
2-wire ( $\sim/\overline{\text{---}}$ ) unprotected (1)	NO or NC programmable		XS7C4A1MPP20	XS8C4A1MPP20	XS8C4A4MPP20	
Weight	kg	0.244	0.244	0.244	0.244	0.244

**Note:** These sensors have an M20 cable entry. They can also be supplied with a PG 13.5 cable entry (e.g. XS8C4A4PCG13) or a 1/2" NPT cable entry (e.g. XS8C4A1MPN12). Please consult our Customer Care Centre.

## Characteristics

Operating zone	mm	0...12	0...16	0...32
Product certifications		cULus, CE, UKCA, E2 (4-wire)		
Conformity to standards		IEC 60947-5-2		
Connection		Screw terminals, clamping capacity: 2 or 4 x 1.5 mm <sup>2</sup> / 2 or 4 x 16 AWG (2)		
Differential travel	%	3...15 of Sr		
Degree of protection		IP 65, IP 67 and IP 69K		
Temperature	Storage	°C	-40...+85	
	Operation (3)	°C	-25...+70	
Material		Case: PBT		
Vibration resistance	Conforming to IEC 60068-2-6		25 gn, amplitude $\pm$ 2 mm (f = 10...55 Hz)	
Shock resistance	Conforming to IEC 60068-2-27		50 gn for 11 ms	
Indicators	Output state		Yellow LED	
	Power on		Green LED, for 4-wire $\overline{\text{---}}$ and 2-wire $\sim/\overline{\text{---}}$ versions	
Rated supply voltage	4-wire $\overline{\text{---}}$	V	12...48 with protection against reverse polarity	
	2-wire $\overline{\text{---}}$	V	12...48 with protection against reverse polarity	
	2-wire $\sim/\overline{\text{---}}$	V	24...240 ( $\sim$ 50/60 Hz)	
Voltage limits (including ripple)	4-wire $\overline{\text{---}}$	V	10...58	
	2-wire $\overline{\text{---}}$	V	10...58	
	2-wire $\sim/\overline{\text{---}}$	V	20...264	
Insulation class			$\overline{\text{---}}$ ; $\square$ $\overline{\text{---}}$ / $\sim$ ; I	
Current consumption, no-load	4-wire $\overline{\text{---}}$	mA	< 15	
Residual current, open state	2-wire $\overline{\text{---}}$	mA	< 0.6	
	2-wire $\sim/\overline{\text{---}}$	mA	1.5	
Switching capacity	4-wire $\overline{\text{---}}$	mA	< 200 with overload and short-circuit protection	
	2-wire $\overline{\text{---}}$	mA	< 100 with overload and short-circuit protection	
	2-wire $\sim/\overline{\text{---}}$	mA	$\sim$ : 5...300 (1) $\overline{\text{---}}$ : 5...200 (1)	
Voltage drop, closed state	4-wire $\overline{\text{---}}$	V	< 2	
	2-wire $\overline{\text{---}}$	V	< 4.2	
	2-wire $\overline{\text{---}}$ / $\sim$	V	< 5.5	
Maximum switching frequency		Hz	Flush mountable: $\overline{\text{---}}$ 300, $\sim$ 25 Non-flush mountable: $\overline{\text{---}}$ 150, $\sim$ 25	
Delays	First-up	Hz	7 ms (3-wire and 4-wire $\overline{\text{---}}$ ), 20 ms (2-wire $\overline{\text{---}}$ and 2-wire $\overline{\text{---}}$ / $\sim$ )	
	Response	ms	Flush mountable: $\leq$ 1.2. Non-flush mountable: $\leq$ 1.4	
	Recovery	ms	Flush mountable: $\leq$ 1.8 ms. Non-flush mountable: $\leq$ 3.5	

(1) Sensor must be protected by a 0.4 A quick-blow fuse connected in series with the load.

(2) These sensors are supplied without a cable gland. An adaptable PG 13.5 cable gland is available (reference XSZPE13). Accessories are available for connection to an M12 or 7/8"-16UN connector which can be added to the PG 13.5 sensor. Please consult our Customer Care Centre.

(3) Sensors are available for very low temperatures (suffix TF: -40°C, +70°C) or very high temperatures (suffix TT: -25°C, +85°C). Please consult our Customer Care Centre.

# Inductive proximity sensors

XS range, general purpose

Plastic case, 40 x 40 x 117 mm, plug-in

5-position turret head

## Setting-up precautions

Minimum mounting distances (mm)

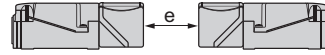
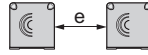

		Side by side	Face to face	Facing a metal object
Sensors flush mountable in metal	XS7C4A1●●	$e \geq 60$	$e \geq 120$	$e \geq 45$
	XS8C4A1●●	$e \geq 80$	$e \geq 160$	$e \geq 60$
Sensors non-flush mountable in metal	XS8C4A4●●	$e \geq 160$	$e \geq 320$	$e \geq 120$

## Wiring schemes

NO + NC outputs

4-wire ~

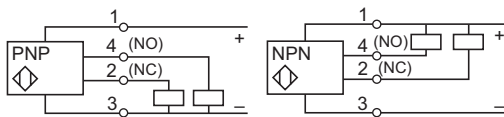

NO or NC outputs, depending on position of link

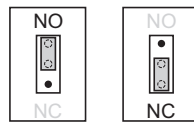

2-wire ~ (non polarised)

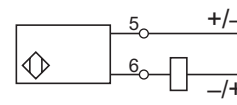

2-wire ~ or ~ (programmable)

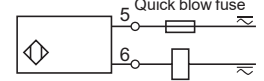

## Dimensions

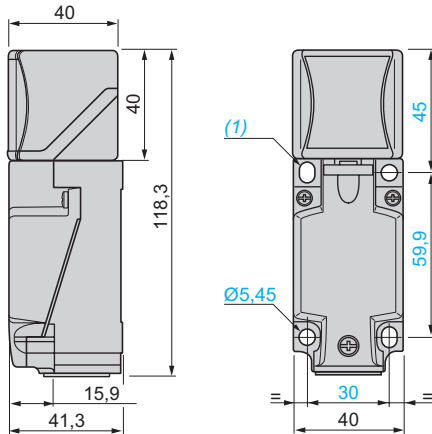

## Head positions

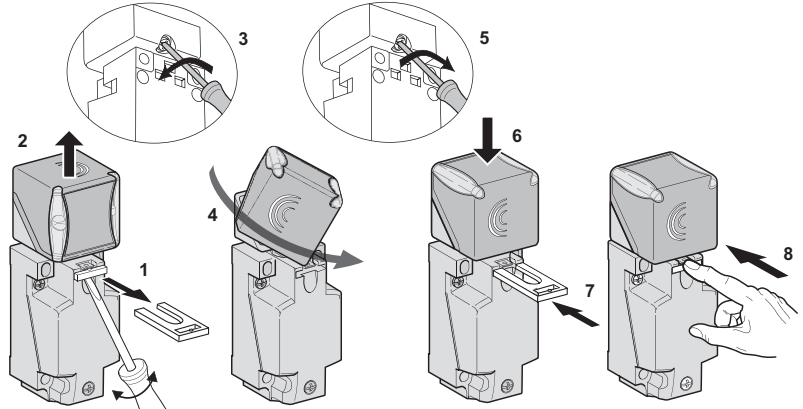

(1) 2 elongated holes  $\varnothing 5.3 \times 7$  cm.

Tightening torque of cover fixing screws and clamp screws:  $< 1.2 \text{ N.m} / < 10.62 \text{ lb-in}$

# Inductive proximity sensors

XS range, general purpose

Multivoltage sensor, cylindrical,

Flush mountable and non-flush mountable

Two-wire AC or DC, short-circuit protection



XS1M●●●●●250



XS2M●●●●●250



XS1M●●●●●250K



XS2M●●●●●250K



XSZB1●●

Sensing distance (Sn) mm	Function	Connection	Reference	Weight (kg)
<b>Ø 18, threaded M18 x 1</b>				
<b>Flush mountable</b>				
5	NO	Pre-cabled (L = 2 m) (1)	<b>XS1M18MA250</b>	0.120
		1/2"-20UNF connector	<b>XS1M18MA250K</b>	0.060
	NC	Pre-cabled (L = 2 m) (1)	<b>XS1M18MB250</b>	0.120
		1/2"-20UNF connector	<b>XS1M18MB250K</b>	0.060
<b>Non flush mountable</b>				
8	NO	Pre-cabled (L = 2 m) (1)	<b>XS2M18MA250</b>	0.120
		1/2"-20UNF connector	<b>XS2M18MA250K</b>	0.060
	NC	Pre-cabled (L = 2 m) (1)	<b>XS2M18MB250</b>	0.120
		1/2"-20UNF connector	<b>XS2M18MB250K</b>	0.060
<b>Ø 30, threaded M30 x 1.5</b>				
<b>Flush mountable</b>				
10	NO	Pre-cabled (L = 2 m) (1)	<b>XS1M30MA250</b>	0.205
		1/2"-20UNF connector	<b>XS1M30MA250K</b>	0.145
	NC	Pre-cabled (L = 2 m) (1)	<b>XS1M30MB250</b>	0.205
		1/2"-20UNF connector	<b>XS1M30MB250K</b>	0.145
<b>Non flush mountable</b>				
15	NO	Pre-cabled (L = 2 m) (1)	<b>XS2M30MA250</b>	0.205
		1/2"-20UNF connector	<b>XS2M30MA250K</b>	0.145
	NC	Pre-cabled (L = 2 m) (1)	<b>XS2M30MB250</b>	0.205
		1/2"-20UNF connector	<b>XS2M30MB250K</b>	0.145

<b>Accessories (2)</b>			
Description	For use with sensors (mm)	Reference	Weight (kg)
Fixing clamps	Ø 18	<b>XSZB118</b>	0.010
	Ø 30	<b>XSZB130</b>	0.020

(1) For a 5 m long cable add L1 to the reference; for a 10 m long cable add L2 to the reference.  
 Example: **XS1M18MA250** becomes **XS1M18MA250L1** with a 5 m long cable.  
 (2) For further information, see page 120.

# Inductive proximity sensors

XS range, general purpose

Multivoltage sensor, cylindrical,

Flush mountable and non-flush mountable



Two-wire AC or DC, short-circuit protection

Characteristics			XS●M●●M●250K	XS●M●●M●250
Sensor type				
Product certifications			cULus, CE, UKCA	
Connection			1/2"-20UNF connector	Pre-cabled, length: 2 m
Operating zone	Ø 18 flush mountable	mm	0...4	
	Ø 18 non-flush mountable	mm	0...6.4	
	Ø 30 flush mountable	mm	0...8	
	Ø 30 non-flush mountable	mm	0...12	
Differential travel		%	1...15 of effective sensing distance (Sr)	
Degree of protection		Conforming to IEC 60529	IP 67	IP 68
Storage temperature			°C - 40...+ 85	
Operating temperature			°C - 25...+ 70	
Materials	Case		Nickel plated brass	
	Cable			PvR 2 x 0.34 mm <sup>2</sup>
Vibration resistance		Conforming to IEC 60068-2-6	25 gn, amplitude ± 2 mm (f = 10 to 55 Hz)	
Shock resistance		Conforming to IEC 60068-2-27	50 gn, duration 11 ms	
Indicators	Output state		Yellow LED, 4 viewing ports at 90°	Yellow LED
	Supply on		-	Green LED
Rated supply voltage		V	~ 24...240 (50/60 Hz) or --- 24...210	
Voltage limits (including ripple)		V	~ or --- 20...264	
Insulation class			I	
Switching capacity		mA	~ 5...300 or --- 5...200 (except Ø 12: ~ or --- 5...200) with overload and short-circuit protection	
Voltage drop, closed state		V	≤ 5.5	
Current consumption, no-load		mA	-	
Residual current, open state		mA	≤ 1.5	
Maximum switching frequency	Ø 18	Hz	~ 25 or --- 2000	
	Ø 30 flush mountable	Hz	~ 25 or --- 2000	
	Ø 30 non-flush mountable	Hz	~ 25 or --- 1000	
Delays	First-up	ms	≤ 70	
	Response	ms	≤ 2 for Ø 18 and Ø 30	
	Recovery	ms	≤ 4 for Ø 18, ≤ 5 for Ø 30 flush mountable, ≤ 10 for Ø 30 non-flush mountable	

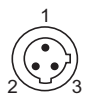
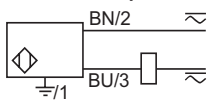
## Wiring schemes

1/2"-20UNF connector	Pre-cabled	2-wire ~ or --- NO or NC output
 <p>+/- : 2 ⊥ : 1 +/- : 3</p>	<p>BU: Blue BN: Brown</p>	 <p>⊥/1</p>
⊥: on connector model only		

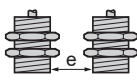
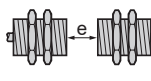
## Setting-up

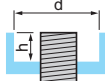
Sensor	Minimum mounting distance (mm)			
	Side by side	Face to face	Facing a metal object	Mounted in a metal support
Ø 18 flush mountable	 e ≥ 10	 e ≥ 60	 e ≥ 15	 d ≥ 18 h ≥ 0
Ø 18 non-flush mountable	e ≥ 16	e ≥ 96	e ≥ 24	d ≥ 54 h ≥ 16
Ø 30 flush mountable	e ≥ 20	e ≥ 120	e ≥ 30	d ≥ 30 h ≥ 0
Ø 30 non-flush mountable	e ≥ 60	e ≥ 180	e ≥ 45	d ≥ 18 h ≥ 0

## Dimensions

Sensor	Flush mountable in metal					XS1M	Non-flush mountable in metal				
	Pre-cabled		Connector		c		Pre-cabled		Connector		c
	a	b	a	b			a	b	a	b	
Ø 18	60	51	72	51	8	60	44	72	44	8	
Ø 30	60	51	72	51	13	63	41	75	41	13	

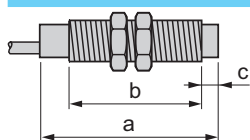

# Inductive proximity sensors

XS range, general purpose

Cylindrical, metal and plastic,

Flush mountable and non-flush mountable

Four-wire DC, solid-state NO + NC output



XS1L06●C410



XS1N12●●●C410



XS2●●●●C410



XS4P●●●●C410D

Sensing distance (Sn) mm	Function	Output	Connection	Reference	Weight (kg)
<b>Ø 6.5 plain</b>					
<b>Stainless steel case, flush mountable</b>					
1.5	NO + NC	PNP	Pre-cabled (L = 2 m)	<b>XS1L06PC410</b>	0.025
<b>Ø 8, threaded M8 x 1</b>					
<b>Stainless steel case, flush mountable</b>					
1.5	NO + NC	PNP (3)	Pre-cabled (L = 2 m)	<b>XS1M08PC410</b>	0.035
			M12 connector	<b>XS1M08PC410D</b>	0.025
<b>Stainless steel case, non-flush mountable</b>					
2.5	NO + NC	PNP (3)	Pre-cabled (L = 2 m)	<b>XS2M08PC410</b>	0.035
			M12 connector	<b>XS2M08PC410D</b>	0.025
<b>Plastic case, non-flush mountable</b>					
2.5	NO + NC	PNP (3)	Pre-cabled (L = 2 m) (1)	<b>XS4P08PC410</b>	0.035
<b>Ø 12, threaded M12 x 1</b>					
<b>Brass case, flush mountable</b>					
2	NO + NC	PNP	Pre-cabled (L = 2 m) (1) (2)	<b>XS1N12PC410</b>	0.070
			M12 connector	<b>XS1N12PC410D</b>	0.020
		NPN	Pre-cabled (L = 2 m) (1)	<b>XS1N12NC410</b>	0.070
			M12 connector	<b>XS1N12NC410D</b>	0.020
<b>Brass case, non-flush mountable</b>					
4	NO + NC	PNP (3)	Pre-cabled (L = 2 m) (1)	<b>XS2N12PC140</b>	0.070
<b>Plastic case, non-flush mountable</b>					
4	NO + NC	PNP (3)	Pre-cabled (L = 2 m) (1)	<b>XS4P12PC410</b>	0.070
			M12 connector	<b>XS4P12PC410D</b>	0.020

(1) For a 5 m long cable add L1 to the reference. Example: XS1N12PC410 becomes XS1N12PC410L1 with a 5 m long cable.

(2) For a 10 m long cable add L2 to the reference. Example: XS1N12PC410 becomes XS1N12PC410L2 with a 10 m long cable.

(3) These sensors can be supplied in NPN versions. Please contact our Customer Care Centre.

# Inductive proximity sensors

XS range, general purpose

Cylindrical, metal and plastic,

Flush mountable and non-flush mountable

Four-wire DC, solid-state NO + NC output



XS4P...C410



XS2N...C410D



XS1N...C410



XSZB1...

Sensing distance (Sn) mm	Function	Output	Connection	Reference	Weight (kg)
<b>Ø 18, threaded M18 x 1</b>					
<b>Brass case, flush mountable</b>					
5	NO + NC	PNP	Pre-cabled (L = 2 m) (1) (2)	<b>XS1N18PC410</b>	0.100
			M12 connector	<b>XS1N18PC410D</b>	0.040
<b>Plastic case, non-flush mountable</b>					
8	NO + NC	PNP (3)	Pre-cabled (L = 2 m)	<b>XS4P18PC410</b>	0.100
			M12 connector	<b>XS4P18PC410D</b>	0.040
<b>Ø 30, threaded M30 x 1.5</b>					
<b>Brass case, flush mountable</b>					
10	NO + NC	PNP	Pre-cabled (L = 2 m) (1) (2)	<b>XS1N30PC410</b>	0.160
			M12 connector	<b>XS1N30PC410D</b>	0.100
<b>Plastic case, non-flush mountable</b>					
15	NO + NC	PNP (3)	Pre-cabled (L = 2 m)	<b>XS4P30PC410</b>	0.160
			M12 connector	<b>XS4P30PC410D</b>	0.100

## Accessories (4)

Description	For use with sensors (mm)	Reference	Weight (kg)
Fixing clamps	Ø 8	<b>XSZB108</b>	0.006
	Ø 12	<b>XSZB112</b>	0.006
	Ø 18	<b>XSZB118</b>	0.010
	Ø 30	<b>XSZB130</b>	0.020

(1) For a 5 m long cable add **L1** to the reference. Example: **XS1N18PC410** becomes **XS1N18PC410L1** with a 5 m long cable.

(2) For a 10 m long cable add **L2** to the reference. Example: **XS1N18PC410** becomes **XS1N18PC410L2** with a 10 m long cable.

(3) These sensors can be supplied in NPN versions. Please contact our Customer Care Centre.

(4) For further information, see page 120.

# Inductive proximity sensors

XS range, general purpose

Cylindrical, metal and plastic

Flush mountable and non-flush mountable

Four-wire DC, solid-state NO + NC output

Characteristics					
Sensor type		XS●●●●PC410D	XS●●●●NC410D	XS●●●●PC410	XS●●●●NC410
Product certifications		cULus, CE, UKCA, E2 (1)	cULus, CE, UKCA	cULus, CE, UKCA, E2	cULus, CE, UKCA
Connection		M12 connector		Pre-cabled, length: 2 m	
Operating zone	Ø 6.5 and Ø 8 flush mountable	mm	0...1.2		
	Ø 8 non-flush mountable	mm	0...2		
	Ø 12 flush mountable	mm	0...1.6		
	Ø 12 non-flush mountable	mm	0...3.2		
	Ø 18 flush mountable	mm	0...4		
	Ø 18 non-flush mountable	mm	0...6.4		
	Ø 30 flush mountable	mm	0...8		
	Ø 30 non-flush mountable	mm	0...12		
Differential travel		%	1...15 of effective sensing distance (Sr)		
Degree of protection	Conforming to IEC 60529	IP 65 and IP 67	IP 67	IP 67 (Ø 6.5 and Ø 8) IP 68 (Ø 12, Ø 18 and Ø 30)	
	Conforming to DIN 40050	IP 69K (Ø 12, Ø 18 and Ø 30)	–	–	
Storage temperature		°C	-40...+85		
Operating temperature		°C	-25...+70 (2)		
Materials	Case	Nickel plated brass for XS1N●●●. Stainless steel 303 for XS1M08●●● and XS2M08●●●. Plastic, PPS, for XS4P●●●.			
	Cable	–	PvR 4 x 0.08 mm <sup>2</sup> (Ø 6.5 and Ø 8) PvR 4 x 0.22 mm <sup>2</sup> (Ø 12, Ø 18 and Ø 30)		
Vibration resistance	Conforming to IEC 60068-2-6	25 gn, amplitude ± 2 mm (f = 10 to 55 Hz)			
Shock resistance	Conforming to IEC 60068-2-27	50 gn, duration 11 ms			
Output state indication		Yellow LED, 4 viewing ports at 90°		Yellow LED, annular	
Rated supply voltage		V --- 12...24 with protection against reverse polarity			
Voltage limits (including ripple)		V --- 9...36 (--- 10...36 for XS4P●●●)	--- 10...36	--- 9...36 (--- 10...36 for XS4P18●●●)	--- 10...36
Insulation class		□	□	□	□
Switching capacity		mA ≤ 200 with overload and short-circuit protection			
Voltage drop, closed state		V ≤ 2			
Current consumption, no-load		mA ≤ 10			
Maximum switching frequency	Ø 6.5, Ø 8 and Ø 12	Hz	5000		
	Ø 18	Hz	2000		
	Ø 30	Hz	1000		
Delays	First-up	ms	≤ 5		
	Response	ms	≤ 0.1 for Ø 8 and Ø 12, ≤ 0.15 for Ø 18, ≤ 0.3 for Ø 30		
	Recovery	ms	≤ 0.1 for Ø 8 and Ø 12, ≤ 0.35 for Ø 18, ≤ 0.7 for Ø 30		

(1) Except XS4P●●●: UL, CSA and CE.

(2) Sensors are available for very low temperatures (suffix TF: -40°C, +70°C) or very high temperatures (suffix TT: -25°C, +85°C). Please consult our Customer Care Centre.

# Inductive proximity sensors

XS range, general purpose

Cylindrical, metal and plastic

Flush mountable and non-flush mountable

Four-wire DC, solid-state NO + NC output

## Wiring schemes

### M12 connector



### Pre-cabled

BU: Blue  
BN: Brown  
BK: Black  
WH: White

### PNP 4-wire

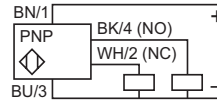

### NPN 4-wire

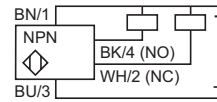

## Setting-up

### Minimum mounting distances (mm)

Sensor	Side by side	Face to face	Facing a metal object	Mounted in a metal support
Ø 6.5 flush mountable XS1L06	$e \geq 3$	$e \geq 18$	$e \geq 4.5$	$d \geq 6.5$ $h \geq 0$
Ø 8 flush mountable XS1M08	$e \geq 3$	$e \geq 18$	$e \geq 4.5$	$d \geq 8$ $h \geq 0$
Ø 8 non-flush mountable XS4P08	$e \geq 10$	$e \geq 30$	$e \geq 7.5$	$d \geq 24$ $h \geq 5$
Ø 12 flush mountable XS1N12	$e \geq 4$	$e \geq 24$	$e \geq 6$	$d \geq 12$ $h \geq 0$
Ø 12 non-flush mountable XS4P12	$e \geq 16$	$e \geq 48$	$e \geq 12$	$d \geq 36$ $h \geq 8$
Ø 18 flush mountable XS1N18	$e \geq 10$	$e \geq 60$	$e \geq 15$	$d \geq 18$ $h \geq 0$
Ø 18 non-flush mountable XS4P18	$e \geq 16$	$e \geq 96$	$e \geq 24$	$d \geq 54$ $h \geq 16$
Ø 30 flush mountable XS1N30	$e \geq 20$	$e \geq 120$	$e \geq 30$	$d \geq 30$ $h \geq 0$
Ø 30 non-flush mountable XS4P30	$e \geq 60$	$e \geq 180$	$e \geq 45$	$d \geq 90$ $h \geq 30$

## Dimensions

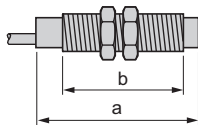

### Flush mountable in metal

Sensor	Pre-cabled (mm)		M12 connector (mm)	
	a	b	a	b
Ø 6.5 XS1L06 stainless steel	50	-	-	-
Ø 8 XS1M08 stainless steel	51	42	62	40
Ø 12 XS1N12 brass	37	25	50	31
Ø 18 XS1N18 brass	41	29	51	28
Ø 30 XS1N30 brass	45	33	54	33

### Non-flush mountable in metal

Sensor	Pre-cabled (mm)		M12 connector (mm)	
	a	b	a	b
Ø 8 XS2M08 stainless steel	54	42	65	40
Ø 8 XS4P08 plastic	34	25	-	-
Ø 12 XS4P12 plastic	37	25	50	31
Ø 18 XS4P18 plastic	41	29	51	28
Ø 30 XS4P30 plastic	45	33	54	33

## Inductive proximity sensors

XS range, general purpose

Cylindrical, metal, increased range, flush mountable

Four-wire DC, solid-state NO + NC output

PF150204



XS100B3PCL2

PF150201



XS112B3PCM12

XS\_515\_CPF\_JR18004



XSZB100

### Sensors, 4-wire $\overline{\text{DC}}$ 12...48 V, long case model

Sensing distance (Sn) mm	Function	Output	Connection	Reference	Weight (kg)
<b>Ø 8, threaded M8 x 1</b>					
2.5	NO + NC	PNP	Pre-cabled (L = 2 m)	<b>XS608B1PCL2</b>	0.035
			M12 connector	<b>XS608B1PCM12</b>	0.025

### Sensors, 4-wire $\overline{\text{DC}}$ 12...24 V, long case model

Sensing distance (Sn) mm	Function	Output	Connection	Reference	Weight (kg)
<b>Ø 12, threaded M12 x 1</b>					
4	NO + NC	PNP	Pre-cabled (L = 2 m)	<b>XS112B3PCL2</b>	0.070
			M12 connector	<b>XS112B3PCM12</b>	0.020
<b>Ø 18, threaded M18 x 1</b>					
8	NO + NC	PNP	Pre-cabled (L = 2 m)	<b>XS118B3PCL2</b>	0.100
			M12 connector	<b>XS118B3PCM12</b>	0.040
<b>Ø 30, threaded M30 x 1.5</b>					
15	NO + NC	PNP	Pre-cabled (L = 2 m)	<b>XS130B3PCL2</b>	0.160
			M12 connector	<b>XS130B3PCM12</b>	0.100

### Accessories (1)

Description	For use with sensors (mm)	Reference	Weight (kg)
Fixing clamps	Ø 8	<b>XSZB108</b>	0.006
	Ø 12	<b>XSZB112</b>	0.006
	Ø 18	<b>XSZB118</b>	0.010
	Ø 30	<b>XSZB130</b>	0.020

(1) For further information, see page 120.

# Inductive proximity sensors

XS range, general purpose

Cylindrical, metal, increased range, flush mountable

Four-wire DC, solid-state NO + NC output

Characteristics		XS1●●B3PCM12 / XS608B1PCM12	XS1●●B3PCL2 / XS608B1PCL2
<b>Sensor type</b>			
<b>Product certifications</b>	Ø 8 Ø 12, 18 and 30	cULus, CE, UKCA cULus, CE, UKCA, E2	
<b>Connection</b>	Connector Pre-cabled	M12 –	– Length 2 m
<b>Operating zone (1)</b>	Ø 8 Ø 12 Ø 18 Ø 30	<b>mm</b> 0...2 <b>mm</b> 0...3.2 <b>mm</b> 0...6.4 <b>mm</b> 0...12	
<b>Differential travel</b>		% 1...15 of effective sensing distance (Sr)	
<b>Degree of protection</b>	Conforming to IEC 60529 Conforming to DIN 40050	IP 65 and IP 67 IP 69K	IP 65 and IP 68 –
<b>Storage temperature</b>		°C -40...+85	
<b>Operating temperature</b>		°C -25...+70 (2)	
<b>Materials</b>	Case Sensing face Cable	Nickel plated brass for Ø 12 to Ø 30, stainless steel grade 303 for Ø 8 PPS –	PvR 4 x 0.22 mm <sup>2</sup> except Ø 8: 4 x 0.08 mm <sup>2</sup>
<b>Vibration resistance</b>	Conforming to IEC 60068-2-6	25 gn, amplitude ± 2 mm (f = 10 to 55 Hz)	
<b>Shock resistance</b>	Conforming to IEC 60068-2-27	50 gn, duration 11 ms	
<b>Output state indication</b>		Yellow LED, 4 viewing ports at 90°	Yellow LED, annular
<b>Rated supply voltage</b>		V --- 12...24 (XS1, XS608), --- 12...48 (XS6 Ø 12, 18, 30), with protection against reverse polarity	
<b>Voltage limits (including ripple)</b>		V --- 9...36	(XS1, XS608) --- 10...58 (XS6 Ø 12, 18, 30)
<b>Insulation class</b>		□	□
<b>Switching capacity</b>		mA ≤ 200 with overload and short-circuit protection	
<b>Voltage drop, closed state</b>		V ≤ 2	
<b>Current consumption, no-load</b>		mA ≤ 10	
<b>Maximum switching frequency</b>	Ø 8 and Ø 12 Ø 18 Ø 30	Hz 2500 Hz 1000 Hz 500	
<b>Delays</b>	First-up Response Recovery	ms ≤ 10 ms ≤ 0.2 for Ø 8 and Ø 12, ≤ 0.3 for Ø 18, ≤ 0.6 for Ø 30 ms ≤ 0.2 for Ø 8 and Ø 12, ≤ 0.7 for Ø 18, ≤ 1.4 for Ø 30	

## Wiring schemes

### M12 connector



### Pre-cabled

BU: Blue  
BN: Brown  
BK: Black  
WH: White

### PNP 4-wire

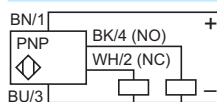

## Setting-up

### Minimum mounting distances (mm)

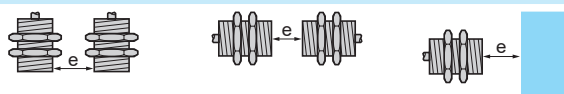

Sensors	Side by side	Face to face	Facing a metal object
Ø 8	e ≥ 5	e ≥ 30	e ≥ 8
Ø 12	e ≥ 8	e ≥ 50	e ≥ 12
Ø 18	e ≥ 16	e ≥ 100	e ≥ 25
Ø 30	e ≥ 30	e ≥ 180	e ≥ 45

## Dimensions

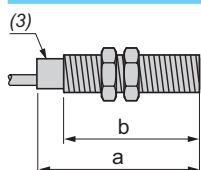

Sensors	Pre-cabled (mm)		M12 connector (mm)	
	a	b	a	b
Ø 8	51	42	61	40
Ø 12	37	25	50	31
Ø 18	41	29	51	28
Ø 30	45	33	54	33

(1) Detection curves, see page 128.

(2) Sensors are available for very low temperatures (suffix TF: -40°C, +70°C) or very high temperatures (suffix TT: -25°C, +85°C). Please consult our Customer Care Centre.

(3) LED.

## Inductive proximity sensors

XS range, general purpose

Cylindrical, metal and plastic, flush and non-flush mountable

Four-wire DC, solid-state PNP + NPN NO/NC

programmable output



103184  
XS1M●●KP340



103812  
XS4P●●KP340



103189  
XS2M●●KP340



103816  
XS4P●●KP340D



XS-XT\_515\_CPODA2018112  
XS1M●●KP340D



PF143827  
XS2M●●KP340D



XS\_515\_CPF\_IR18004  
XSZB1●●

Sensing distance (Sn) mm	Function	Output	Connection	Reference	Weight (kg)
<b>Ø 12, threaded M12 x 1</b>					
<b>Metal case, flush mountable</b>					
2	NO/NC programmable	PNP + NPN	Pre-cabled (L = 2 m) (1) M12 connector	<b>XS1M12KP340</b> <b>XS1M12KP340D</b>	0.075 0.025
<b>Metal case, non-flush mountable</b>					
4	NO/NC programmable	PNP + NPN	Pre-cabled (L = 2 m) (1) M12 connector	<b>XS2M12KP340</b> <b>XS2M12KP340D</b>	0.075 0.025
<b>Plastic case, non-flush mountable</b>					
4	NO/NC programmable	PNP + NPN	Pre-cabled (L = 2 m) (1) M12 connector	<b>XS4P12KP340</b> <b>XS4P12KP340D</b>	0.075 0.025
<b>Ø 18, threaded M18 x 1</b>					
<b>Metal case, flush mountable</b>					
5	NO/NC programmable	PNP + NPN	Pre-cabled (L = 2 m) (1) M12 connector	<b>XS1M18KP340</b> <b>XS1M18KP340D</b>	0.120 0.060
<b>Metal case, non-flush mountable</b>					
8	NO/NC programmable	PNP + NPN	Pre-cabled (L = 2 m) (1) M12 connector	<b>XS2M18KP340</b> <b>XS2M18KP340D</b>	0.120 0.060
<b>Plastic case, non-flush mountable</b>					
8	NO/NC programmable	PNP + NPN	Pre-cabled (L = 2 m) (1) M12 connector	<b>XS4P18KP340</b> <b>XS4P18KP340D</b>	0.120 0.060
<b>Ø 30, threaded M30 x 1.5</b>					
<b>Metal case, flush mountable</b>					
10	NO/NC programmable	PNP + NPN	Pre-cabled (L = 2 m) (1) M12 connector	<b>XS1M30KP340</b> <b>XS1M30KP340D</b>	0.205 0.145
<b>Metal case, non-flush mountable</b>					
15	NO/NC programmable	PNP + NPN	Pre-cabled (L = 2 m) (1) M12 connector	<b>XS2M30KP340</b> <b>XS2M30KP340D</b>	0.205 0.145
<b>Plastic case, non-flush mountable</b>					
15	NO/NC programmable	PNP + NPN	Pre-cabled (L = 2 m) (1) M12 connector	<b>XS4P30KP340</b> <b>XS4P30KP340D</b>	0.205 0.145

### Accessories (2)

Description	For use with sensors (mm)	Reference	Weight (kg)
Fixing clamps	Ø 12	<b>XSZB112</b>	0.006
	Ø 18	<b>XSZB118</b>	0.010
	Ø 30	<b>XSZB130</b>	0.020

(1) For a 5 m long cable add L1 to the reference; for a 10 m long cable add L2 to the reference.

Example: XS1M12KP340 becomes XS1M12KP340L1 with a 5 m long cable.

(2) For further information, see page 120.

# Inductive proximity sensors

XS range, general purpose

Cylindrical, metal and plastic, flush and non-flush mountable

Four-wire DC, solid-state PNP + NPN NO/NC

programmable output

Characteristics		XS●M●●KP340D	XS●M●●KP340
Sensor type			
Product certifications		cULus, CE, UKCA	
Connection		M12 connector	Pre-cabled, length: 2 m
Operating zone	Ø 12 flush mountable	mm	0...1.6
	Ø 12 non-flush mountable	mm	0...3.2
	Ø 18 flush mountable	mm	0...4
	Ø 18 non-flush mountable	mm	0...6.4
	Ø 30 flush mountable	mm	0...8
	Ø 30 non-flush mountable	mm	0...12
Differential travel		%	1...15 of effective sensing distance (Sr)
Degree of protection	Conforming to IEC 60529	IP 67	IP 68
Storage temperature		°C	- 40...+ 85
Operating temperature		°C	- 25...+ 70
Materials	Case	Nickel plated brass for XS1M and XS2M, PPS for XS4P	
	Cable		PvR 4 x 0.34 mm <sup>2</sup>
Vibration resistance	Conforming to IEC 60068-2-6	25 gn, amplitude ± 2 mm (f = 10 to 55 Hz)	
Shock resistance	Conforming to IEC 60068-2-27	50 gn, duration 11 ms	
Output state indication		Yellow LED, 4 viewing ports at 90°	Yellow LED, annular
Rated supply voltage		V	--- 12...24 with protection against reverse polarity
Voltage limits (including ripple)		V	--- 10...36
Insulation class			
Switching capacity		mA	≤ 200 with overload and short-circuit protection
Voltage drop, closed state		V	≤ 2.6
Current consumption, no-load		mA	≤ 10
Maximum switching frequency	Ø 12	Hz	5000
	Ø 18	Hz	2000
	Ø 30 flush mountable	Hz	1000
	Ø 30 non-flush mountable	Hz	1000
Delays	First-up	ms	≤ 5
	Response	ms	≤ 0.1 for Ø 12, ≤ 0.15 for Ø 18, ≤ 0.3 for Ø 30
	Recovery	ms	≤ 0.1 for Ø 12, ≤ 0.35 for Ø 18, ≤ 0.7 for Ø 30

## Wiring schemes

M12 connector	Pre-cabled	PNP + NPN
	BU: Blue BN: Brown BK: Black WH: White	<b>4-wire programmable, NO or NC output</b>
		<b>PNP</b> 
		<b>NPN</b> 

## Setting-up

Sensor	Minimum mounting distances (mm)			
	Side by side	Face to face	Facing a metal object	Mounted in a metal support
Ø 12 flush mountable XS1M12	e ≥ 4	e ≥ 24	e ≥ 6	d ≥ 12 h ≥ 0
Ø 12 non-flush mountable XS2M12 and XS4P12	e ≥ 16	e ≥ 48	e ≥ 12	d ≥ 36 h ≥ 8
Ø 18 flush mountable XS1M18	e ≥ 10	e ≥ 60	e ≥ 15	d ≥ 18 h ≥ 0
Ø 18 non-flush mountable XS2M18 and XS4P18	e ≥ 16	e ≥ 96	e ≥ 24	d ≥ 54 h ≥ 16
Ø 30 flush mountable XS1M30	e ≥ 20	e ≥ 120	e ≥ 30	d ≥ 30 h ≥ 0
Ø 30 non-flush mountable XS2M30 and XS4P30	e ≥ 60	e ≥ 180	e ≥ 45	d ≥ 90 h ≥ 30

## Dimensions

Sensor	Flush mountable in metal				Non-flush mountable in metal				
	Pre-cabled		Connector		Pre-cabled		Connector		c
	a	b	a	b	a	b	a	b	
Ø 12 metal	54	42	61	42	55	42	66	42	5
Ø 12 plastic	-	-	-	-	54	42	61	43	0
Ø 18 metal	60	51	72	51	60	44	72	44	8
Ø 18 plastic	-	-	-	-	60	51	70	51	0
Ø 30 metal	60	51	72	51	63	41	75	41	13
Ø 30 plastic	-	-	-	-	60	51	70	51	0

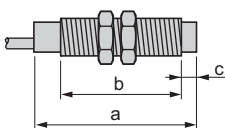



# Inductive proximity sensors

XS range, general purpose  
Plastic, cylindrical, non-flush mountable  
Two-wire AC or DC  
Three-wire DC, solid-state output



XS4P●●●●340  
XS4P●●●●370  
XS4P●●●●230



XS4P08●●340S



XS4P●●●●340D  
XS4P●●●●370D  
XS4P●●●●230K

Sensing dist. (Sn) mm	Function	Output	Connection	Reference	Weight (kg)
<b>Ø 8, threaded M8 x 1</b>					
<b>Three-wire <math>\overline{\text{---}}</math> 12-24 V</b>					
2.5	NO	PNP	Pre-cabled (L = 2 m) (1) (2)	<b>XS4P08PA340</b>	0.025
		NPN	Pre-cabled (L = 2 m) (1) (2)	<b>XS4P08NA340</b>	0.025
	NC	PNP	Pre-cabled (L = 2 m) (1) (2)	<b>XS4P08PB340</b>	0.025
		NPN	Pre-cabled (L = 2 m) (1) (2)	<b>XS4P08NB340</b>	0.025
<b>Two-wire <math>\sim</math> or <math>\overline{\text{---}}</math> 24-240 V</b>					
2.5	NO		Pre-cabled (L = 2 m) (1)	<b>XS4P08MA230</b>	0.030
	NC		Pre-cabled (L = 2 m) (1)	<b>XS4P08MB230</b>	0.030
<b>Ø 12, threaded M12 x 1</b>					
<b>Three-wire <math>\overline{\text{---}}</math> 12-24 V</b>					
4	NO	PNP	Pre-cabled (L = 2 m) (1) (3)	<b>XS4P12PA340</b>	0.060
		NPN	Pre-cabled (L = 2 m) (1) (3)	<b>XS4P12NA340</b>	0.060
	NC	PNP	Pre-cabled (L = 2 m) (1) (3)	<b>XS4P12PB340</b>	0.060
		NPN	Pre-cabled (L = 2 m) (1) (3)	<b>XS4P12NB340</b>	0.060
<b>Three-wire <math>\overline{\text{---}}</math> 12-48 V</b>					
4	NO	PNP	Pre-cabled (L = 2 m) (1) (3)	<b>XS4P12PA370</b>	0.065
		NPN	Pre-cabled (L = 2 m) (1) (3)	<b>XS4P12NA370</b>	0.065
	NC	PNP	Pre-cabled (L = 2 m) (1) (3)	<b>XS4P12PB370</b>	0.065
<b>Two-wire <math>\sim</math> or <math>\overline{\text{---}}</math> 24-240 V</b>					
4	NO		Pre-cabled (L = 2 m) (1)	<b>XS4P12MA230</b>	0.065
			1/2"-20UNF connector	<b>XS4P12MA230K</b>	0.030
	NC		Pre-cabled (L = 2 m) (1)	<b>XS4P12MB230</b>	0.065
<b>Ø 18, threaded M18 x 1</b>					
<b>Three-wire <math>\overline{\text{---}}</math> 12-24 V</b>					
8	NO	PNP	Pre-cabled (L = 2 m) (1) (3)	<b>XS4P18PA340</b>	0.090
		NPN	Pre-cabled (L = 2 m) (1) (3)	<b>XS4P18NA340</b>	0.090
	NC	PNP	Pre-cabled (L = 2 m) (1) (3)	<b>XS4P18PB340</b>	0.090
<b>Three-wire <math>\overline{\text{---}}</math> 12-48 V</b>					
8	NO	PNP	Pre-cabled (L = 2 m) (1) (3)	<b>XS4P18PA370</b>	0.100
		NPN	Pre-cabled (L = 2 m) (1) (3)	<b>XS4P18NA370</b>	0.100
	NC	PNP	Pre-cabled (L = 2 m) (1) (3)	<b>XS4P18PB370</b>	0.100
<b>Two-wire <math>\sim</math> or <math>\overline{\text{---}}</math> 24-240 V</b>					
8	NO		Pre-cabled (L = 2 m) (1)	<b>XS4P18MA230</b>	0.100
			1/2"-20UNF connector	<b>XS4P18MA230K</b>	0.040
	NC		Pre-cabled (L = 2 m) (1)	<b>XS4P18MB230</b>	0.100
			1/2"-20UNF connector	<b>XS4P18MB230K</b>	0.040
<b>Ø 30, threaded M30 x 1.5</b>					
<b>Three-wire <math>\overline{\text{---}}</math> 12-24 V</b>					
15	NO	PNP	Pre-cabled (L = 2 m) (1) (3)	<b>XS4P30PA340</b>	0.120
		NPN	Pre-cabled (L = 2 m) (1) (3)	<b>XS4P30NA340</b>	0.120
	NC	PNP	Pre-cabled (L = 2 m) (1) (3)	<b>XS4P30PB340</b>	0.120
<b>Three-wire <math>\overline{\text{---}}</math> 12-48 V</b>					
15	NO	PNP	Pre-cabled (L = 2 m) (1) (3)	<b>XS4P30PA370</b>	0.140
	NC	PNP	Pre-cabled (L = 2 m) (3)	<b>XS4P30PB370</b>	0.140
<b>Two-wire <math>\sim</math> or <math>\overline{\text{---}}</math></b>					
15	NO		Pre-cabled (L = 2 m) (1)	<b>XS4P30MA230</b>	0.140
			1/2"-20UNF connector	<b>XS4P30MA230K</b>	0.080
	NC		Pre-cabled (L = 2 m) (1)	<b>XS4P30MB230</b>	0.140
			1/2"-20UNF connector	<b>XS4P30MB230K</b>	0.080

(1) For a 5 m long cable add L1 to the reference; for a 10 m long cable add L2 to the reference. Example: XS4P08PA340 becomes XS4P08PA340L1 with a 5 m long cable.  
 (2) For an M8 connector, add S to the reference. Example: XS4P08PA340 becomes XS4P08PA340S with an M8 connector.  
 (3) For an M12 connector, add D to the reference. Example: XS4P12PA370 becomes XS4P12PA370D with an M12 connector.

# Inductive proximity sensors

XS range, general purpose



Plastic, cylindrical, non-flush mountable

Two-wire AC or DC

Three-wire DC, solid-state output

Characteristics		XS4P●●●●340●	XS4P●●●●370●	XS4P●●M●230●
Sensor type		cULus, CE, UKCA, ECOLAB		
Product certifications		Length: 2 m		
Connection	Pre-cabled	M8 on Ø 8 M12 on Ø 12, Ø 18 and Ø 30		
	Connector	1/2"-20UNF		
Operating zone	Ø 8	mm	0...2	
	Ø 12	mm	0...3.2	
	Ø 18	mm	0...6.4	
	Ø 30	mm	0...12	
Differential travel		%	1...15 of effective sensing distance (Sr)	
Degree of protection		Conforming to IEC 60529	IP 68 for pre-cabled version (except Ø 8: IP 67) IP 67 for connector version	
Storage temperature		°C	- 40...+ 85	
Operating temperature		°C	- 25...+ 70	
Materials	Case	PPS		
	Cable	PvR 3 x 0.34 mm <sup>2</sup> except Ø 8: 3 x 0.11 mm <sup>2</sup>		PvR 2 x 0.34 mm <sup>2</sup> except Ø 8: 2 x 0.11 mm <sup>2</sup>
Vibration resistance		Conforming to IEC 60068-2-6	25 gn, amplitude ± 2 mm (f = 10 to 55 Hz)	
Shock resistance		Conforming to IEC 60068-2-27	50 gn, duration 11 ms	
Output state indication		Yellow LED: annular on pre-cabled version Yellow LED: 4 viewing ports at 90° on connector version		
Rated supply voltage		V	--- 12...24 with protection against reverse polarity	--- 12...48 with protection against reverse polarity ~ or --- 24...240 (50/60 Hz)
Voltage limits (including ripple)		V	--- 10...36	--- 10...58 ~ or --- 20...264
Insulation class			II	I
Switching capacity	Ø 8	mA	≤ 200 with overload and short-circuit protection	5...100
	Ø 12			5...200
	Ø 18 and 30			5...200 --- and 5...300 ~
Voltage drop, closed state		V	≤ 2	≤ 5.5
Residual current, open state		mA	–	≤ 0.6
Current consumption, no-load		mA	≤ 10	–
Maximum switching frequency	Ø 8 and Ø 12	Hz	5000	--- 3000, ~ 25
	Ø 18	Hz	2000	--- 2000, ~ 25
	Ø 30	Hz	1000	--- 1000, ~ 25
Delays	First-up	ms	≤ 10	≤ 40
	Response	ms	≤ 0.1 for Ø 8 and Ø 12, ≤ 0.15 for Ø 18, ≤ 0.3 for Ø 30	≤ 0.2
	Recovery	ms	≤ 0.1 for Ø 8 and Ø 12, ≤ 0.35 for Ø 18, ≤ 0.7 for Ø 30	≤ 0.2 for Ø 8, Ø 12 and Ø 18, ≤ 0.4 for Ø 30

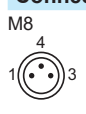
## Wiring schemes

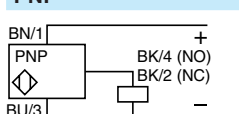
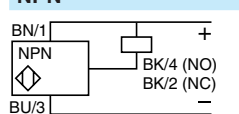
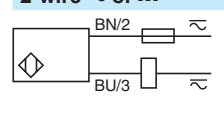
Connector	Pre-cabled	PNP	NPN	2-wire ~ or ---
 M8  M12  1/2"-20UNF	BU: Blue BN: Brown BK: Black	 BN/1 + BK/4 (NO) BK/2 (NC) BU/3 -	 BN/1 + BK/4 (NO) BK/2 (NC) BU/3 -	 BN/2 ~ BU/3 ~
For M8 connector, NO and NC outputs on terminal 4				

## Setting-up

### Minimum mounting distances (mm)

	Side by side	Face to face	Facing a metal object	Mounted in a metal support
Ø 8	e ≥ 10	e ≥ 30	e ≥ 7.5	d ≥ 24 h ≥ 5
Ø 12	e ≥ 16	e ≥ 48	e ≥ 12	d ≥ 36 h ≥ 8
Ø 18	e ≥ 16	e ≥ 96	e ≥ 24	d ≥ 54 h ≥ 16
Ø 30	e ≥ 60	e ≥ 180	e ≥ 45	d ≥ 90 h ≥ 30

## Dimensions

XS4P	3-wire --- 12-24 V				3-wire --- 12-48 V or 2-wire ~ / --- 24-240 V			
	Pre-cabled (mm)		Connector (mm)		Pre-cabled (mm)		Connector (mm)	
	a	b	a	b	a	b	a	b
Ø 8	33	26	42	26	50	42	61	40
Ø 12	35	25	48	27	54	42	61	42
Ø 18	36	25	48	29	62	52	70	52
Ø 30	43	32	50	34	62	52	70	52

# Inductive proximity sensors

XS range, general purpose

Cylindrical, quasi-flush mountable, increased range

Three-wire DC, solid-state output



XS1N●●●●●349



XS1N●●●●●349D



XSZB1●●

## References

Sensing distance (Sn) (mm)	Function	Output	Connection	Reference	Weight (kg)
<b>Ø 12, threaded M12 x 1</b>					
4	NO	PNP	Pre-cabled (L = 2 m)	<b>XS1N12PA349</b>	0.070
			M12 connector	<b>XS1N12PA349D</b>	0.020
	NPN	PNP	Pre-cabled (L = 2 m)	<b>XS1N12NA349</b>	0.070
			M12 connector	<b>XS1N12NA349D</b>	0.020
NC	PNP	Pre-cabled (L = 2 m)	<b>XS1N12PB349</b>	0.070	
		M12 connector	<b>XS1N12PB349D</b>	0.020	
<b>Ø 18, threaded M18 x 1</b>					
10	NO	PNP	Pre-cabled (L = 2 m)	<b>XS1N18PA349</b>	0.100
			M12 connector	<b>XS1N18PA349D</b>	0.040
	NPN	PNP	Pre-cabled (L = 2 m)	<b>XS1N18NA349</b>	0.100
			M12 connector	<b>XS1N18NA349D</b>	0.040
NC	PNP	Pre-cabled (L = 2 m)	<b>XS1N18PB349</b>	0.100	
		M12 connector	<b>XS1N18PB349D</b>	0.040	
<b>Ø 30, threaded M30 x 1.5</b>					
20	NO	PNP	Pre-cabled (L = 2 m)	<b>XS1N30PA349</b>	0.160
			M12 connector	<b>XS1N30PA349D</b>	0.100
	NPN	PNP	Pre-cabled (L = 2 m)	<b>XS1N30NA349</b>	0.160
			M12 connector	<b>XS1N30NA349D</b>	0.100
NC	PNP	Pre-cabled (L = 2 m)	<b>XS1N30PB349</b>	0.160	
		M12 connector	<b>XS1N30PB349D</b>	0.100	



## Accessories (1)

Description	For use with sensors (mm)	Reference	Weight (kg)
Fixing clamps	Ø 12	<b>XSZB112</b>	0.006
	Ø 18	<b>XSZB118</b>	0.010
	Ø 30	<b>XSZB130</b>	0.020

(1) For further information, see page 120.

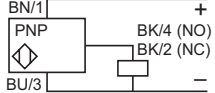
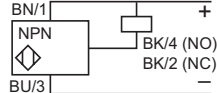

Characteristics		XS1●●●●●349D	XS1●●●●●349
Sensor type		cULus, CE, UKCA	
Product certifications		M12 connector	
Connection		Pre-cabled, length: 2 m	
Operating zone	Ø 8	mm	0...2
	Ø 12	mm	0...3.2
	Ø 18	mm	0...8
	Ø 30	mm	0...16
Differential travel		%	1...15 of effective sensing distance (Sr)
Degree of protection	Conforming to IEC 60529	IP 67	IP 68 (except Ø 8: IP 67)
	Conforming to DIN 40050	IP 69K for Ø 12 to Ø 30	
Storage temperature		°C	-40...+85
Operating temperature		°C	-25...+70
Materials	Case	Nickel plated brass	
	Cable	PvR 3 x 0.34 mm <sup>2</sup> except Ø 8: 3 x 0.11 mm <sup>2</sup>	
Vibration resistance	Conforming to IEC 60068-2-6	25 gn, amplitude ± 2 mm (f = 10 to 55 Hz)	
Shock resistance	Conforming to IEC 60068-2-27	50 gn, duration 11 ms	
Output state indication		Yellow LED, 4 viewing ports at 90°	Yellow LED, annular
Rated supply voltage		V	12...24 with protection against reverse polarity
Voltage limits (including ripple)		V	10...36
Insulation class		II	
Switching capacity		mA	≤ 200 with overload and short-circuit protection
Voltage drop, closed state		V	≤ 2
Current consumption, no-load		mA	≤ 10
Maximum switching frequency	Ø 8 and Ø 12	Hz	2500
	Ø 18	Hz	1000
	Ø 30	Hz	500
Delays	First-up	ms	≤ 5
	Response	ms	≤ 0.2 for Ø 8 and Ø 12, ≤ 0.3 for Ø 18, ≤ 0.6 for Ø 30
	Recovery	ms	≤ 0.2 for Ø 8 and Ø 12, ≤ 0.7 for Ø 18, ≤ 1.4 for Ø 30

## Wiring schemes

Connector	Pre-cabled	PNP 3-wire	NPN 3-wire
M8 	M12 	BU: Blue BN: Brown BK: Black 	

For M8 connector, NO and NC outputs on terminal 4

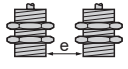
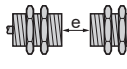
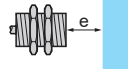
## Setting-up precautions

Sensor	Minimum mounting distances (mm)			
	Side by side	Face to face	Facing a metal object	Mounted in a metal support
Ø 8	 e ≥ 5	 e ≥ 30	 e ≥ 7.5	 d ≥ 10 h ≥ 1.6
Ø 12	e ≥ 8	e ≥ 48	e ≥ 12	d ≥ 14 h ≥ 2.4
Ø 18	e ≥ 20	e ≥ 96	e ≥ 30	d ≥ 28 h ≥ 3.6
Ø 30	e ≥ 40	e ≥ 240	e ≥ 60	d ≥ 50 h ≥ 6

## Dimensions

Sensor	Flush mountable in metal					
	Pre-cabled		M8 connector		M12 connector	
	a	b	a	b	a	b
Ø 8	33	25	42	26	45	23
Ø 12	35	25	—	—	50	30
Ø 18	39	28	—	—	50	28
Ø 30	43	32	—	—	55	32



# Inductive proximity sensors

XS range, general purpose

Miniature, cylindrical, quasi-flush mountable

Three-wire DC, solid-state output



XS604R1PAL2



XS504R1NAM08



XS604R1NBL2



XS505R1PAM08

## Ø 4 plain

Sensing distance (Sn) mm	Function	Output	Connection	Reference	Weight (kg)
<b>Stainless steel case, quasi-flush mountable</b>					
1,5	NO	PNP	Pre-cabled (L = 2 m)	<b>XS604R1PAL2</b>	0.030
			M8 connector	<b>XS604R1PAM08</b>	0.004
	NPN	PNP	Pre-cabled (L = 2 m)	<b>XS604R1NAL2</b>	0.030
			M8 connector	<b>XS604R1NAM08</b>	0.004
	NC	PNP	Pre-cabled (L = 2 m)	<b>XS604R1PBL2</b>	0.030
			M8 connector	<b>XS604R1PBM08</b>	0.004
NPN	PNP	Pre-cabled (L = 2 m)	<b>XS604R1NBL2</b>	0.030	
		M8 connector	<b>XS604R1NBM08</b>	0.004	
0,8	NO	PNP	Pre-cabled (L = 2 m)	<b>XS504R1PAL2</b>	0.030
			M8 connector	<b>XS504R1PAM08</b>	0.004
	NPN	PNP	Pre-cabled (L = 2 m)	<b>XS504R1NAL2</b>	0.030
			M8 connector	<b>XS504R1NAM08</b>	0.004
	NC	PNP	Pre-cabled (L = 2 m)	<b>XS504R1PBL2</b>	0.030
			M8 connector	<b>XS504R1PBM08</b>	0.004
NPN	PNP	Pre-cabled (L = 2 m)	<b>XS504R1NBL2</b>	0.030	
		M8 connector	<b>XS504R1NBM08</b>	0.004	

## Ø 5, threaded M5 x 0.5

Sensing distance (Sn) mm	Function	Output	Connection	Reference	Weight (kg)
<b>Stainless steel case, quasi-flush mountable</b>					
1,5	NO	PNP	Pre-cabled (L = 2 m)	<b>XS605R1PAL2</b>	0.030
			Pre-cabled (L = 5 m)	<b>XS605R1PAL5</b>	0.030
	NPN	PNP	M8 connector	<b>XS605R1PAM08</b>	0.004
			Pre-cabled (L = 2 m)	<b>XS605R1NAL2</b>	0.030
	NC	PNP	M8 connector	<b>XS605R1NAM08</b>	0.004
			Pre-cabled (L = 2 m)	<b>XS605R1PBL2</b>	0.030
NPN	PNP	M8 connector	<b>XS605R1PBM08</b>	0.004	
		Pre-cabled (L = 2 m)	<b>XS605R1NBL2</b>	0.030	
M8 connector	PNP	Pre-cabled (L = 2 m)	<b>XS605R1NBM08</b>	0.004	
		M8 connector	<b>XS605R1NBM08</b>	0.004	
0.8	NO	PNP	Pre-cabled (L = 2 m)	<b>XS505R1PAL2</b>	0.030
			M8 connector	<b>XS505R1PAM08</b>	0.004
	NPN	PNP	Pre-cabled (L = 2 m)	<b>XS505R1NAL2</b>	0.030
			M8 connector	<b>XS505R1NAM08</b>	0.004
	NC	PNP	Pre-cabled (L = 2 m)	<b>XS505R1PBL2</b>	0.030
			M8 connector	<b>XS505R1PBM08</b>	0.004
NPN	PNP	Pre-cabled (L = 2 m)	<b>XS505R1NBL2</b>	0.030	
		M8 connector	<b>XS505R1NBM08</b>	0.004	

# Inductive proximity sensors

XS range, general purpose

Miniature, cylindrical, quasi-flush mountable

Three-wire DC, solid-state output

Characteristics				XS0400000M08 XS0500000M08	XS0400000L2 XS0500000L2
Sensor type					
Product certifications				cULus, CE, UKCA	UL, CE, UKCA
Connection (1)	Connector		M8	-	
	Pre-cabled	Length	m	-	2 for XS0000000L2 5 for XS6050000L5
Operating zone	XS504	mm	0...0.65		
	XS505	mm	0...0.65		
	XS604	mm	0...1.21		
	XS605	mm	0...1.21		
Degree of protection				Conforming to IEC 60529	
Storage temperature				°C -40...+85	
Operating temperature				°C -25...+70	
Materials	Case		Stainless steel 303		
	Cable		PVC 3x0.149 mm <sup>2</sup>		
Vibration resistance				Conforming to IEC 60947-5-2	
Shock resistance				Conforming to IEC 60947-5-2	
Output state indication	LED		Yellow LED		
	Visibility		4 viewing ports at 90°		1 viewing port
Rated supply voltage				V $\bar{\bar{}}$ 12...24	
Voltage limits (including ripple)				V $\bar{\bar{}}$ 10...30	
Insulation class				III	
Current consumption, no-load				mA $\leq$ 10	
Switching capacity				3-wire PNP/NPN	
Voltage drop, closed state				V $\leq$ 1.5	
Maximum switching frequency				kHz 5	
Delays				First-up	
				ms 50	

(1) Detection curves, see page 128

## Wiring schemes

Connector	Pre-cabled	PNP 3-wire	NPN 3-wire
M8 	BU: Blue BN: Brown BK: Black		

## Setting-up

Minimum mounting distances (mm)						
Sensor	d4	d1	d2	d3	d4	d5
Ø 4 XS504 steel	$\geq 2$ (1)	$\geq 3$ (2)	$\geq 0$ (3)	$\geq 4$	$\geq 8$	$\geq 2.4$
Ø 4 XS604 steel	$\geq 3$ (1)	$\geq 4$ (2)	$\geq 0$ (3)	$\geq 4$	$\geq 8$	$\geq 4.5$
Ø 5 XS505 steel	$\geq 0$ (1)	$\geq 1$ (2)	$\geq 0$ (3)	$\geq 5$	$\geq 5$	$\geq 2.4$
Ø 5 XS605 steel	$\geq 1$ (1)	$\geq 2$ (2)	$\geq 0$ (3)	$\geq 5$	$\geq 10$	$\geq 4.5$

(1) If mounting environment is ferro-magnetic metal, such as iron, cobalt, nickel, gadolinium, neodymium, etc.  
 (2) If mounting environment is non ferro-magnetic metal, such as aluminium, copper, brass, gold, silver, titanium, etc.  
 (3) If mounting environment is non-metal, such as plastic, wood, etc.

## Tightening torque

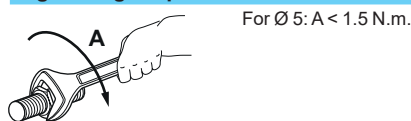

## Dimensions

Sensor	Pre-cabled		M8 connector	
	a	b	a	b
Ø 4 XS04	30.2	-	38.4	-
Ø 5 XS05	30.2	26.5	38.4	22.1

# Inductive proximity sensors

XS range, general purpose

Miniature, cylindrical, flush mountable

Three-wire DC, solid-state output



XS1L04●●310



XS1L04●●310S



XS1N05●●311S



XS1N05●●310

## Ø 4 plain

Sensing distance (Sn) mm	Function	Output	Connection (1)	Reference	Weight (kg)
<b>Brass case, flush mountable</b>					
1	NO	PNP	Pre-cabled (L = 2 m)	<b>XS1L04PA310</b>	0,025
			M8 connector	<b>XS1L04PA310S</b>	0.010
	NPN	PNP	Pre-cabled (L = 2 m)	<b>XS1L04NA310</b>	0.025
			M8 connector	<b>XS1L04NA310S</b>	0.010
	NC	PNP	Pre-cabled (L = 2 m)	<b>XS1L04PB310</b>	0.025
			M8 connector	<b>XS1L04PB310S</b>	0.010
NPN	PNP	Pre-cabled (L = 2 m)	<b>XS1L04NB310</b>	0.025	
		M8 connector	<b>XS1L04NB310S</b>	0.010	

## Stainless steel case, flush mountable

0,8	NO	PNP	Pre-cabled (L = 2 m)	<b>XS1L04PA311</b>	0,025
			M8 connector	<b>XS1L04PA311S</b>	0.010
	NPN	PNP	Pre-cabled (L = 2 m)	<b>XS1L04NA311</b>	0.025
			M8 connector	<b>XS1L04NA311S</b>	0.010
	NC	PNP	Pre-cabled (L = 2 m)	<b>XS1L04PB311</b>	0.025
			M8 connector	<b>XS1L04PB311S</b>	0.010
NPN	PNP	Pre-cabled (L = 2 m)	<b>XS1L04NB311</b>	0.025	
		M8 connector	<b>XS1L04NB311S</b>	0.010	

## Ø 5, threaded M5 x 0.5

Sensing distance (Sn) mm	Function	Output	Connection (1)	Reference	Weight (kg)
<b>Brass case, flush mountable</b>					
1	NO	PNP	Pre-cabled (L = 2 m)	<b>XS1N05PA310</b>	0,030
			NPN	Pre-cabled (L = 2 m)	<b>XS1N05NA310</b>
	NC	PNP	Pre-cabled (L = 2 m)	<b>XS1N05PB310</b>	0,030
			NPN	Pre-cabled (L = 2 m)	<b>XS1N05NB310</b>

## Stainless steel case, flush mountable

0.8	NO	PNP	Pre-cabled (L = 2 m)	<b>XS1N05PA311</b>	0.030
			M8 connector	<b>XS1N05PA311S</b>	0.015
	NPN	PNP	Pre-cabled (L = 2 m)	<b>XS1N05NA311</b>	0.030
			M8 connector	<b>XS1N05NA311S</b>	0.015
	NC	PNP	Pre-cabled (L = 2 m)	<b>XS1N05PB311</b>	0.030
			M8 connector	<b>XS1N05PB311S</b>	0.004
NPN	PNP	Pre-cabled (L = 2 m)	<b>XS1N05NB311</b>	0.004	
		M8 connector	<b>XS1N05NB311S</b>	0.015	

(1) For a 5 m long cable add L1 to the reference; for a 10 m long cable add L2 to the reference.  
Example: XS1L04PA310 becomes XS1L04PA310L1 with a 5 m long cable.

# Inductive proximity sensors

XS range, general purpose  
Miniature, cylindrical, flush mountable  
Three-wire DC, solid-state output

Characteristics			
Sensor type		XS1L04●●●●●●S, XS1N05●●●●●●S	XS1L04●●●●●●, XS1N05●●●●●●
Product certifications		cULus, CE, UKCA	
Connection (1)	Connector	M8	–
	Pre-cabled Length	m	2
Operating zone	Ø 4 brass	mm	0...0.8
	Ø 4 stainless steel	mm	0...0.6
	Ø 5 brass	mm	0...0.8
	Ø 5 stainless steel	mm	0...0.6
Degree of protection	Conforming to IEC 60529	IP 67	
Storage temperature		°C	- 40...+ 85
Operating temperature		°C	- 25...+ 70
Materials	Case	Nickel plated brass or stainless steel 303	
	Cable	PvR 3 x 0.11 mm <sup>2</sup>	
Vibration resistance	Conforming to IEC 60068-2-6	25 gn, amplitude ± 2 mm (f = 10 to 55 Hz)	
Shock resistance	Conforming to IEC 60068-2-27	50 gn, duration 11 ms	
Output state indication	LED	Yellow LED	
	Visibility	1 viewing port	
Rated supply voltage		V	≐ 5...24
Voltage limits (including ripple)		V	≐ 5...30
Insulation class			□
Current consumption, no-load		mA	≤ 10
Switching capacity	3-wire PNP/NPN	mA	≤ 100 with overload and short-circuit protection
Voltage drop, closed state		V	≤ 2
Maximum switching frequency		kHz	5
Delays	First-up	ms	≤ 5
	Response	ms	≤ 0.1
	Recovery	ms	≤ 0.1

(1) Detection curves, see page 128

## Wiring schemes

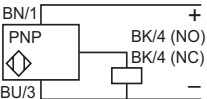
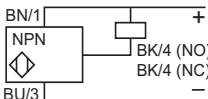
Connector	Pre-cabled	PNP 3-wire	NPN 3-wire
M8 	BU: Blue BN: Brown BK: Black		

## Setting-up

### Minimum mounting distances (mm)

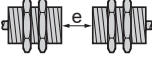
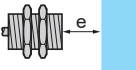
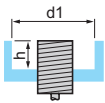
Sensor	Side by side	Face to face	Facing a metal object
Ø 4 XS1L04●●●●●●	 e ≥ 2	 e ≥ 12	 e ≥ 3
Ø 5 XS1N05●●●●●●	e ≥ 2	e ≥ 12	e ≥ 3
			 d1 ≥ 4, h ≥ 0 d1 ≥ 5, h ≥ 0

### Tightening torque

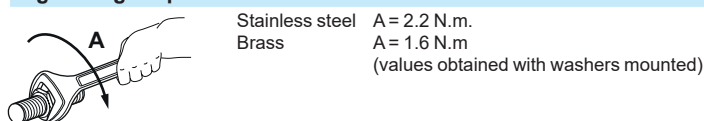

## Dimensions

Sensor	Pre-cabled		M8 connector	
	a	b	a	b
Ø 4 XS1L04●●●●●●	28	–	43	–
Ø 5 XS1N05●●●●●●	28	24	43	24

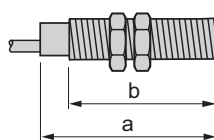

# Inductive proximity sensors

XS range application

Adjustable range sensors

Cylindrical, flush mountable using teach mode (1)

Three-wire DC, solid-state output

103854



XS6●●B2●●L01M12

### Ø 12, threaded M12 x 1

Sensing distance (Sn) mm	Function	Output	Connection	Reference	Weight (kg)
5	NO	PNP	Remote M12 connector on 0.15 m flying lead	<b>XS612B2PAL01M12</b>	0.100
	NC	PNP	Remote M12 connector on 0.15 m flying lead	<b>XS612B2PBL01M12</b>	0.100

### Ø 18, threaded M18 x 1

Sensing distance (Sn) mm	Function	Output	Connection	Reference	Weight (kg)
9	NO	PNP	Remote M12 connector on 0.15 m flying lead	<b>XS618B2PAL01M12</b>	0.140
	NC	PNP	Remote M12 connector on 0.15 m flying lead	<b>XS618B2PBL01M12</b>	0.140

### Ø 30, threaded M30 x 1.5

Sensing distance (Sn) mm	Function	Output	Connection	Reference	Weight (kg)
18	NO	PNP	Remote M12 connector on 0.15 m flying lead	<b>XS630B2PAL01M12</b>	0.220

XS\_515\_CPF-IR18004



XSZB1●●

### Accessories (2)

Description	For use with sensors (mm)	Reference	Weight (kg)
Fixing clamps	Ø 12	<b>XSZB112</b>	0.006
	Ø 18	<b>XSZB118</b>	0.010
	Ø 30	<b>XSZB130</b>	0.020

(1) For further information on flush or non-flush mountable sensors using teach mode, see page 22.

(2) For further information, see page 120.

# Inductive proximity sensors

XS range application

Adjustable range sensors

Cylindrical, flush mountable using teach mode

Three-wire DC, solid-state output

Characteristics		XS6●●B2●●L01M12	
Sensor type		cULus, CE, UKCA	
Product certifications		Remote M12 connector on 0.15 m flying lead	
Sensing distance and adjustment zone	Ø 12	Nominal sensing distance (Sn)	mm 0...5 non-flush mounted / 0...3.4 flush mounted
		Precision adjustment zone	mm 1.7...5 non-flush mounted / 1.7...3.4 flush mounted
	Ø 18	Nominal sensing distance (Sn)	mm 0...9 non-flush mounted / 0...6 flush mounted
		Precision adjustment zone	mm 3...9 non-flush mounted / 3...6 flush mounted
	Ø 30	Nominal sensing distance (Sn)	mm 0...18 non-flush mounted / 0...11 flush mounted
		Precision adjustment zone	mm 6...18 non-flush mounted / 6...11 flush mounted
Differential travel		% 1...15 of effective sensing distance (Sr)	
Degree of protection		Conforming to IEC 60529 IP 67	
Storage temperature		°C - 40...+ 85	
Operating temperature		°C - 25...+ 70	
Materials	Case	Nickel plated brass	
	Remote control	PBT	
	Cable	PvR - Ø 4.2 mm	
Vibration resistance		Conforming to IEC 60068-2-6 25 gn, amplitude ± 2 mm (f = 10 to 55 Hz)	
Shock resistance		Conforming to IEC 60068-2-27 50 gn, duration 11 ms	
Indicators	Output state	Yellow LED	
	Supply on and teach mode	Green LED	
Rated supply voltage		V --- 12...24 with protection against reverse polarity	
Voltage limits (including ripple)		V --- 10...36	
Insulation class		□	
Switching capacity		mA ≤ 100 with overload and short-circuit protection	
Voltage drop, closed state		V ≤ 2	
Current consumption, no-load		mA ≤ 10	
Maximum switching frequency		Hz 1000	
Delays	First-up	ms ≤ 10	
	Response	ms ≤ 0.3	
	Recovery	ms ≤ 0.7	

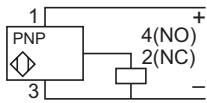
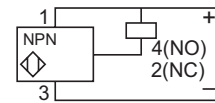
Wiring schemes	
Connector M12 	<b>PNP</b> 
	<b>NPN</b> 

Setting-up		Minimum mounting distances (mm)		
Ø 12	Side by side flush mounted	not flush mounted	Face to face flush mounted	Facing a metal object
		not flush mounted	not flush mounted	
	Ø 18	not flush mounted	not flush mounted	not flush mounted
		not flush mounted	not flush mounted	not flush mounted
Ø 30	not flush mounted	not flush mounted	not flush mounted	
	not flush mounted	not flush mounted	not flush mounted	

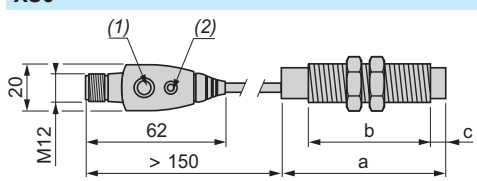
Dimensions		XS6		
Ø 12		Connector (mm)		
		a	b	c
		59	42	5
		Ø 18	64	44
Ø 30	62.6	41	13	

# Inductive proximity sensors

## XS range application

Sensors for rotation monitoring, slip detection,  
shaft overload detection

Cylindrical form

**Example:**  
Coupling breakage monitoring

BZZ138

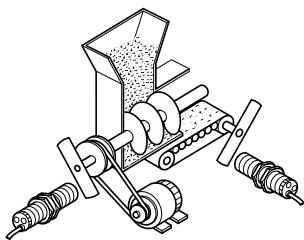

DF602242

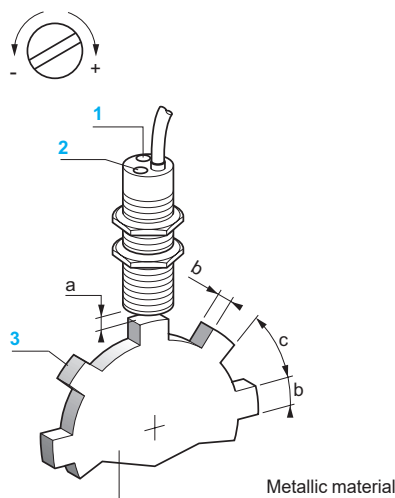

### Functions

These self-contained rotation speed monitoring sensors have the special feature of incorporating, in the same case, the pulse sensing and processing electronics as well as the output switching amplifier that are required to establish an integrated rotation monitoring device.

The unit provides an economical solution for detecting slip, belt breakage, drive shaft shear and overloading, etc., in the following applications: conveyor belts, bucket elevators, Archimedian screws, grinders, crushers, pumps, centrifugal driers, mixers, etc.

### Operating principle

The output signal of this type of sensor is processed by an impulse comparator incorporated in the sensor. The impulse frequency  $F_c$  generated by the moving part to be monitored is compared to the frequency  $F_r$  preset on the sensor. The output switching circuit of the sensor is in the closed state for  $F_c > F_r$  and the open state for  $F_c < F_r$ .

Sensors XSAV are particularly suitable for the detection of underspeed: when the speed of the moving part  $F_c$  falls below a preset threshold  $F_r$ , this causes the output circuit of the sensor to switch off.

**Note:** Following power-up, the operational status of the sensor is subject to a delay of 9 seconds in order for the moving part being monitored to run-up to its nominal speed. During this time, the output of the sensor remains in the closed state.

### Adjustment of frequency threshold

- Adjustment of sensor's frequency threshold: using potentiometer, 15 turns approximately.
- To increase the frequency threshold: turn the adjustment screw clockwise (+).
- To decrease the frequency threshold: turn the adjustment screw anti-clockwise (-).

1: Potentiometer	Diameter of sensor		
2: LED	a	b	c
3: Metal target	M30	4...6 mm	30 mm
			60 mm

### Potentiometer adjustment curves (for XSAV1●801, 2-wire ~ or - sensors)

Low speed version (6...150 impulses/minute)      High speed version (120...3000 impulses/minute)

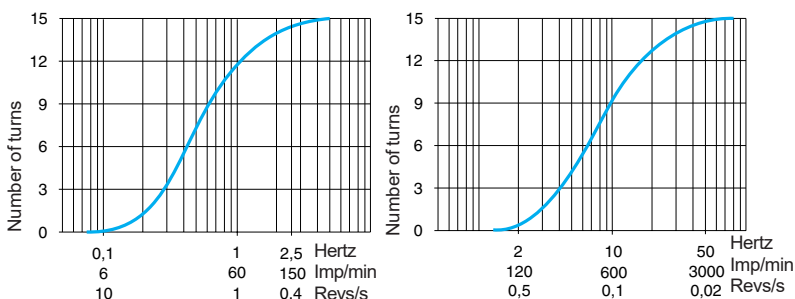

### Setting-up

#### Minimum distances (mm)

Side by side

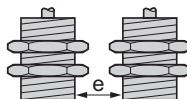

$e \geq 20$

Facing a metal object

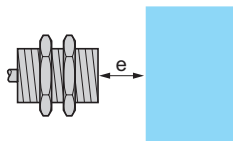

$e \geq 30$

Face to face

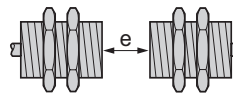

$e \geq 120$

Mounted in a metal support

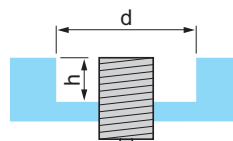

$d \geq 30, h \geq 0$

Fixing nut tightening torque:  $< 50 \text{ N.m} / 442.53 \text{ lb-in}$

# Inductive proximity sensors

## XS range application

Sensors for rotation monitoring, slip detection,  
shaft overload detection

Cylindrical form

### Flush mountable in metal

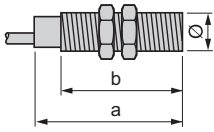

Lengths (mm):  
a = Overall  
b = Threaded section

a = 81  
b = 67  
Ø = M30

	DC	DC	AC/DC	AC/DC
Nominal sensing distance (Sn)	10 mm	10 mm	10 mm	10 mm
Adjustable frequency range	6...150 impulses/min	120...3000 impulses/min	6...150 impulses/min	120...3000 impulses/min

### References

3-wire	PNP / NC	XSAV11373	XSAV12373	–	–
2-wire	~ or ~ / NC	–	–	XSAV11801	XSAV12801
Weight (kg)		0,300			

### Characteristics

Product certifications	cULus, CCC, CE, UKCA		
Connection	Pre-cabled, 3 x 0.34 mm <sup>2</sup> , length 2 m (1)	Pre-cabled, 2 x 0.34 mm <sup>2</sup> , length 2 m (1)	
Degree of protection conforming to IEC 60529	IP 67		
Operating zone	mm	0...8	
Repeat accuracy	%	3 of Sr	
Differential travel	%	3...15 of Fr	
Operating temperature	°C	- 25...+ 70	
Output state indication	Red LED		
Rated supply voltage	V	~ 12...48 with protection against reverse polarity	~ 24...240 (50/60 Hz) or ~ 24...210
Voltage limits (including ripple)	V	~ 10...58	~ or ~ 20...264
Insulation class	Ⓜ		
Switching capacity	mA	≤ 200 with overload and short-circuit protection	~ 5...350 or ~ 5...200 (2)
Voltage drop, closed state	V	≤ 1.8	≤ 5.7
Residual current, open state	mA	–	≤ 1.5
Current consumption, no-load	mA	≤ 15	–
Maximum switching frequency	6000 impulses/min (for XSAV11●●●); 48,000 impulses/min (for XSAV12●●●)		
“Run-up” delay following power-up	9 seconds ± 20 % + 1/Fr (3)		

### Wiring schemes

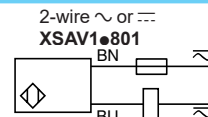
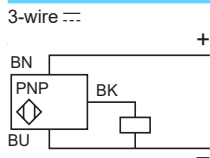

(1) For a 5 m long cable add L05 to the reference, for a 10 m long cable add L10 to the reference.

Example: XSAV11373 becomes XSAV11373L05 with a 5 m long cable.

(2) These sensors do not incorporate overload or short-circuit protection and therefore, it is essential to connect a 0.4 A “quick-blow” fuse in series with the load, see page 120.

(3) For a sensor without a “run-up” delay following power-up, replace XSAV1 in the reference by XSAV0. Example: XSAV11801 becomes XSAV01801 without a “run-up” delay. For a reduced “run-up” delay of 3 s, replace XSAV1 in the reference by XSAV3.

# Inductive proximity sensors

## XS range application

Sensors for rotation monitoring, slip detection and shaft overload detection, with teach mode

### Operating principle and applications

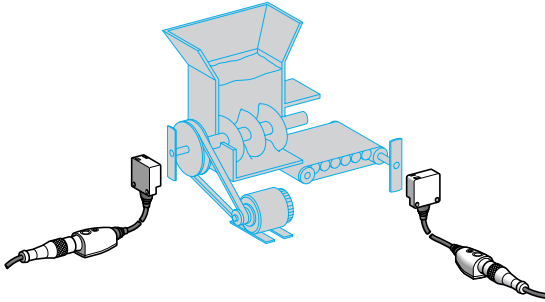

- These inductive proximity sensors are designed for monitoring rotational speed or the speed of the flow of objects to be protected or monitored. They operate on the principle of comparing a speed threshold preset by the operator against the instantaneous measurement of the speed of the moving object to be protected.
- They provide a simple, economical solution for detecting slip, belt breakage, coupling breakage and overload, etc.
- They are widely used in grinder/crusher, mixer, pump, centrifugal driver, conveyor belt, bucket elevator, Archimedeian screw, etc. type applications.

### Installation and setting-up

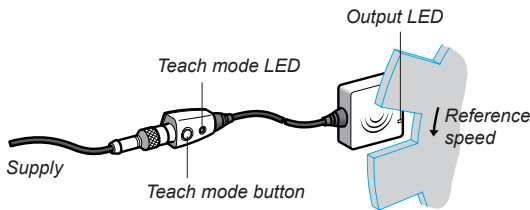

#### Setting-up and positioning the sensor

- In the positioning phase, the XS9 sensor can operate as a standard inductive sensor (Schneider Electric patent). Operation in inductive mode enables validation of reliable detection of all the moving objects to be monitored.
- Using this system, the positioning is therefore made 100 % reliable and can be checked at any time without altering the settings of the sensor.

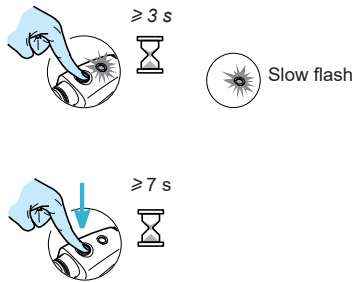

#### Speed adjustment in teach mode

- The normal or reference speed of the moving object (1) to be monitored is adjusted by simply pressing the teach mode button (2) and is then validated by the display LED.
- If in doubt, the sensor can be reset at any time to the factory settings.
- (1) To allow the moving object to reach its normal speed (machine inertia), the sensor holds its output closed for 9 seconds.
- (2) The sensor's default drop-out underspeed corresponds to the preset speed - 30 %.  
Example: If the preset speed is 1000 rpm, the sensor drops out on underspeed when the speed of the moving object drops below  $1000 - (1000 \times 0.3) = 700$  rpm.  
- 20 %, - 11 % and - 6 % thresholds can be obtained by pressing the teach mode button.

### Setting-up

#### Minimum mounting distances (mm)

Type	Side by side	Face to face
XS9E	$e \geq 40$	$e \geq 80$
XS9C	$e \geq 60$	$e \geq 120$

### Dimensions

#### XS9E, XS9C

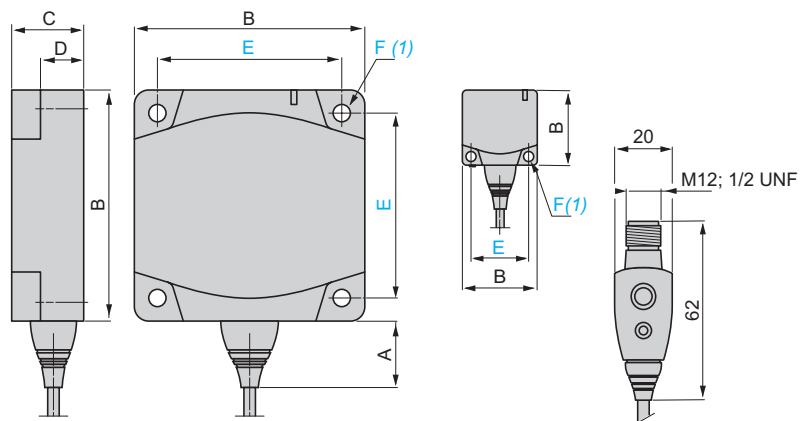

(1) For CHC type screws

Type	A	B	C	D	E	F
XS9E	14	26	13	8.8	20	3.5
XS9C	14	40	15	9.8	33	4.5

# Inductive proximity sensors

## XS range application

Sensors for rotation monitoring, slip detection and shaft overload detection, with teach mode

<b>Sensor type</b>	<b>Flush mountable in metal</b>	
	<b>PBT case</b>	
		
<b>Nominal sensing distance (Sn)</b>	<b>10 mm</b>	<b>15 mm</b>
<b>Adjustable frequency range</b>	6...6000 impulses/min	

### References

<b>3-wire</b>	PNP / NC	<b>XS9E11RPBL01M12</b>	–	–
<b>2-wire</b>	⋯ or ~ / NC	–	<b>XS9E11RMBL01U20</b>	<b>XS9C11RMBL01U20</b>
<b>Weight (kg)</b>		0.040	0.040	0.060

### Characteristics

<b>Product certifications</b>		cULus, CE, UKCA		
<b>Connection</b>		Remote M12 connector on 0.15 m flying lead	Remote 1/2"-20UNF connector on 0.15 m flying lead	
<b>Operating zone</b>	<b>mm</b>	<b>0...8</b>	<b>0...8</b>	<b>0...12</b>
<b>Degree of protection</b>	Conforming to IEC 60529	IP 67		
<b>Storage temperature</b>	<b>°C</b>	- 40...+ 85		
<b>Operating temperature</b>	<b>°C</b>	- 25...+ 70		
<b>Vibration resistance</b>	Conforming to IEC 60068-2-6	25 gn, amplitude ± 2 mm (f = 10 to 55 Hz)		
<b>Shock resistance</b>	Conforming to IEC 60068-2-27	50 gn, duration 11 ms		
<b>Indicators</b>	Output state	Yellow LED		
	Supply on	Green LED		
<b>Rated supply voltage</b>	<b>V</b>	⋯ 12...24	~ or ⋯ 24...240 (50/60 Hz)	
<b>Voltage limits (including ripple)</b>	<b>V</b>	⋯ 10...36	~ or ⋯ 20...264	
<b>Insulation class</b>		I		
<b>Switching capacity</b>	<b>mA</b>	≤ 100 (1)	~ or ⋯ 5...100 (2)	⋯ 5...200, ~ 5...300(2)
<b>Voltage drop, closed state</b>	<b>V</b>	≤ 2	≤ 5.5	
<b>Residual current, open state</b>	<b>mA</b>	≤ 100	≤ 1.5	
<b>Current consumption, no-load</b>	<b>mA</b>	≤ 10	–	
<b>Maximum switching frequency</b>		48,000 impulses/min		
<b>"Run-up" delay following power-up</b>		9 seconds + 1/Fr		

(1) With overload and short-circuit protection.

(2) It is essential to connect a 0.4 A "quick-blow" fuse in series with the load.

### Wiring schemes

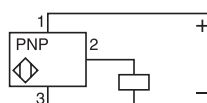
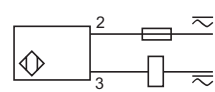
Connector		<b>3-wire ⋯</b>	<b>2-wire ~ or ⋯</b>
<b>M12</b>	<b>1/2"-20UNF</b>	<b>XS9•11RPBL01M12</b>	<b>XS9•11RMBL01U20</b>
			

### Accessory (1)

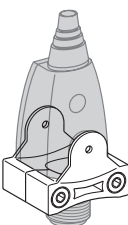
	<b>Description</b>	<b>Reference</b>	<b>Weight (kg)</b>
	<b>Remote control fixing clamp</b>	<b>XSZBPM12</b>	0.015

XSZBPM12

(1) For accessories, see page 120.

# Inductive proximity sensors

## XS range application

Sensors with analogue output signal 0...10 V <sup>(1)</sup>

or 4...20 mA

For position, displacement and deformation control/monitoring

### Functions

Example:  
Sorting parts

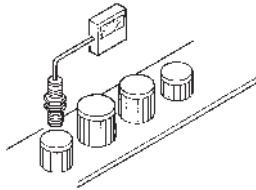

These analogue output proximity sensors are solid-state sensors designed for monitoring displacement. They are not measuring sensors. They are suitable for use in many sectors, particularly for applications involving:

- deformation and displacement monitoring,
- vibration amplitude and frequency monitoring,
- control of dimensional tolerances,
- position control,
- concentricity or eccentricity monitoring.

### Operating principle

The operating principle of the sensor is that of a damped oscillator. The degree of damping will depend on the distance of an object from the sensing face. The sensor will sense the distance and produce an output current with a value directly proportional to this distance.

### Output curves 4..0.20 mA, 2-wire connection

**XS1M12AB120**

Sn = 0.2...2 mm

Ø 12 mm

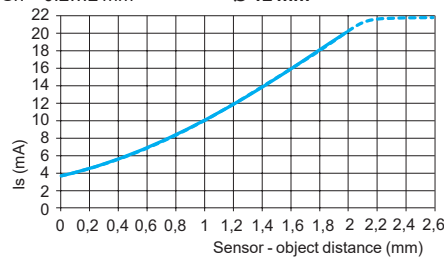

**XS1M18AB120**

Sn = 0.5...5 mm

Ø 18 mm

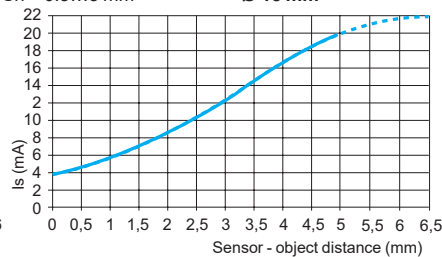

**XS1M30AB120**

Sn = 1...10 mm

Ø 30 mm

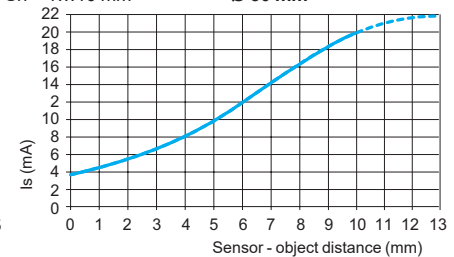

**XS4P12AB120**

Sn = 0.4...4 mm

Ø 12 mm

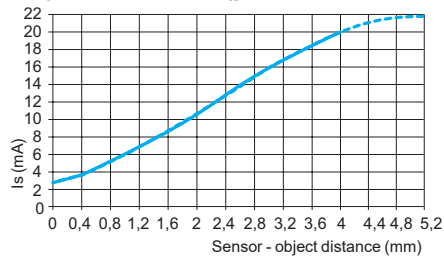

**XS4P18AB120**

Sn = 0.8...8 mm

Ø 18 mm

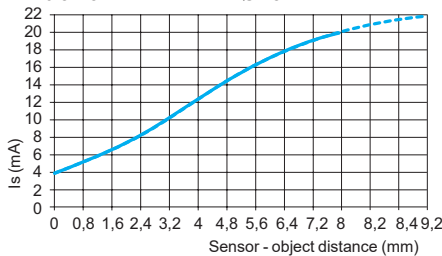

**XS4P30AB120**

Sn = 1.5...15 mm

Ø 30 mm

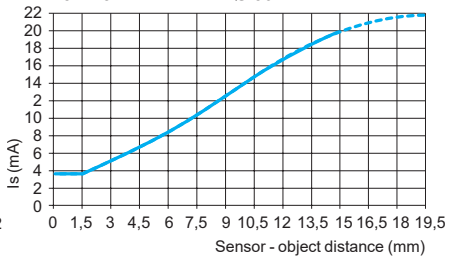

### Output curves 0...10 V, 3-wire connection

**XS4P12AB110**

Sn = 0.4...4 mm

Ø 12 mm

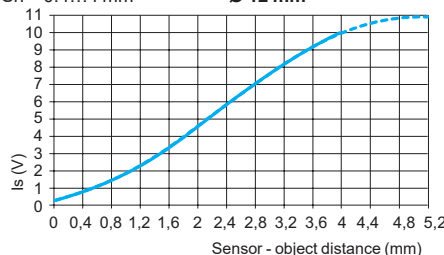

**XS4P18AB110**

Sn = 0.8...8 mm

Ø 18 mm

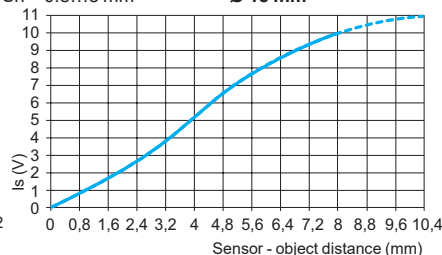

**XS4P30AB110**

Sn = 1.5...15 mm

Ø 30 mm

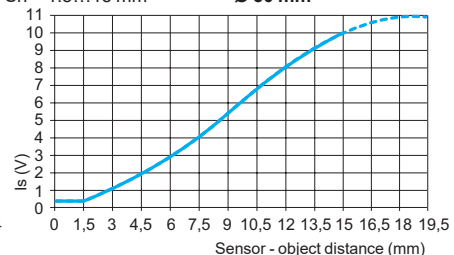

### Wiring schemes

#### 2-wire connection

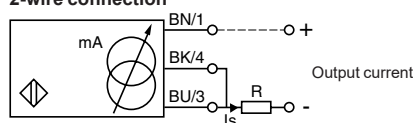

Output current

Load impedance value

12 V	4...20 mA	$R \leq 8.2 \Omega$
24 V	4...20 mA	$R \leq 470 \Omega$

Ensure a minimum of 10 V between the + and the - (terminal 3) of the sensor.

#### 3-wire connection

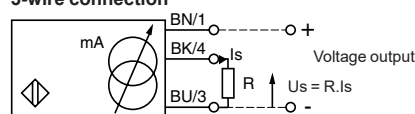

Output current

Load impedance value

Output voltage

Load impedance value

24 V	0...10 mA	$R \leq 1500 \Omega$	0...10 V	$R = 1000 \Omega$
48 V	0...10 mA	$R \leq 3300 \Omega$	0...10 V	$R = 1000 \Omega$

Ensure a minimum of 5 V between the + and the sensor output (terminal 4).

<sup>(1)</sup> Voltage range only obtained with a load impedance of 1000  $\Omega$ .





# Inductive proximity sensors

XS range application

Sensors with analogue output signal 0...10 V <sup>(1)</sup>

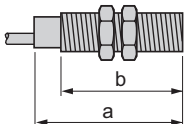
or 4...20 mA

For position, displacement and deformation control/monitoring

Sensor type	Flush mountable in metal	Non-flush mountable in metal	
			
Lengths: a = Overall b = Threaded section	mm a = 50 b = 42	a = 50 b = 42	a = 54 b = 42

	Metal case	Plastic case	Plastic case
Nominal sensing distance (S <sub>n</sub> )	mm 2	4	4

References			
3-wire --- Output 0...10 V (2)	---	---	XS4P12AB110 (4)
2-wire --- Output 4...20 mA (2)	XS1M12AB120 (3) (4)	XS4P12AB120 (4)	---
Weight	kg 0.075	0.065	0.065

Characteristics			
Product certifications	cULus, CE, UKCA		
Connection	Pre-cabled, PvR 3 x 0.34 mm <sup>2</sup> , length 2 m		
Degree of protection Conforming to IEC 60529	IP 67		
Operating zone	mm 0.2...2	0.4...4	0.4...4
Repeat accuracy	% ± 3		
Linearity error	mA ± 2	± 1 V	
Ambient air temperature	°C For operation: - 25...+ 70		
Rated supply voltage	V --- 12...24	--- 12...24	--- 24...48
Voltage limits (including ripple)	V --- 10...36	--- 10...36	--- 15...58
Insulation class	Ⓜ	Ⓜ	Ⓜ
Output current drift	% ≤ 10 (ambient temperature: - 25...+ 70 °C)		
Current consumption, no-load	mA 4		
Maximum operating rate	Hz 1500		

(1) Voltage range only obtained with a load impedance of 1000 Ω.

(2) Output current range Is, see page 82.

(3) Add D at the end of reference for M12 connector version

(4) For 5 m cable, add L1 at the end of the reference

## Setting-up

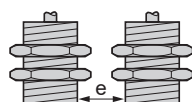
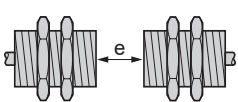
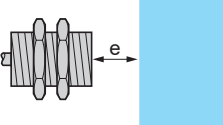
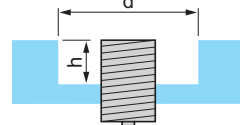



Minimum mounting distances (mm)	Side by side	Face to face	Facing a metal object	Mounted in a metal support
XS1M12AB120 flush mountable	 e ≥ 4	 e ≥ 24	 e ≥ 6	 d ≥ 12, h ≥ 0
XS4P12AB110 non-flush mountable	e ≥ 16	e ≥ 48	e ≥ 12	d ≥ 36, h ≥ 8
XS4P12AB120 non-flush mountable	e ≥ 16	e ≥ 48	e ≥ 12	d ≥ 36, h ≥ 8

Fixing nut tightening torque	< 6 N.m (metal case), < 2 N.m (plastic case)
Other versions	Please consult our Customer Care Centre.

# Inductive proximity sensors

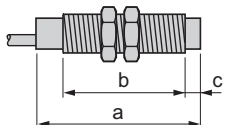
## XS range application

Sensors with analogue output signal 0...10 V <sup>(1)</sup>  
or 4...20 mA

Sensor type	Flush mountable in metal	Non-flush mountable in metal	
			
Lengths (mm): a = Overall b = Threaded section c = For non-flush mountable sensors	mm a = 53 b = 44 c = 0	a = 41 b = 26 c = 8	a = 41 b = 26 c = 8
Nominal sensing distance (S <sub>n</sub> )	mm	Metal case 5	Plastic case 8

References			
3-wire $\overline{\text{---}}$ Output 0...10 V <sup>(2)</sup>	–	–	XS4P18AB110 <sup>(4)</sup>
2-wire $\overline{\text{---}}$ Output 4...20 mA <sup>(2)</sup>	XS1M18AB120 <sup>(3)</sup> <sup>(4)</sup>	XS4P18AB120 <sup>(4)</sup>	–
Weight	kg	0.120	0.080

Characteristics			
Product certifications		cULus, CE, UKCA	
Connection		Pre-cabled, PvR 3 x 0.34 mm <sup>2</sup> , length 2 m	
Degree of protection Conforming to IEC 60529		IP 67	
Operating zone	mm	0.5...5	0.8...8
Repeat accuracy	%	± 3	
Linearity error	mA	± 2	± 1 V
Ambient air temperature	°C	For operation: - 25...+ 70	
Rated supply voltage	V	$\overline{\text{---}}$ 12...24	$\overline{\text{---}}$ 24...48
Voltage limits (including ripple)	V	$\overline{\text{---}}$ 10...36	$\overline{\text{---}}$ 15...58
Insulation class		Ⓜ	Ⓜ
Output current drift	%	≤ 10 (ambient temperature: - 25...+ 70 °C)	
Current consumption, no-load	mA	4	
Maximum operating rate	Hz	500	





<sup>(1)</sup> Voltage range only obtained with a load impedance of 1000 Ω.

<sup>(2)</sup> Output current range is, see page 82.

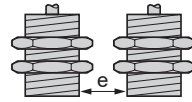
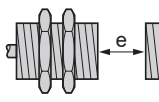
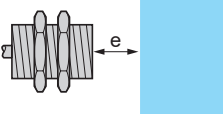
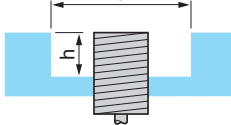
<sup>(3)</sup> Add D at the end of reference for M12 connector version

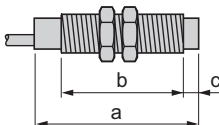
<sup>(4)</sup> For 5 m cable, add L1 at the end of the reference

Setting-up				
Minimum mounting distances (mm)	Side by side	Face to face	Facing a metal object	Mounted in a metal support
				
XS1M18AB120 flush mountable	e ≥ 10	e ≥ 60	e ≥ 15	d ≥ 18, h ≥ 0
XS4P18AB110 non-flush mountable	e ≥ 32	e ≥ 96	e ≥ 24	d ≥ 54, h ≥ 16
XS4P18AB120 non-flush mountable	e ≥ 32	e ≥ 96	e ≥ 24	d ≥ 54, h ≥ 16
Fixing nut tightening torque	< 15 N.m (metal case), < 5 N.m (plastic case)			
Other versions	Please consult our Customer Care Centre.			

Sensor type	Flush mountable in metal	Non-flush mountable in metal	
			
Lengths: a = Overall b = Threaded section c = For non-flush mountable sensors	mm a = 50 b = 42 c = 0	a = 53 b = 32 c = 13	a = 53 b = 32 c = 13
	<b>Metal case</b>	<b>Plastic case</b>	<b>Plastic case</b>
Nominal sensing distance (Sn)	mm 10	15	15

References			
3-wire --- Output 0...10 V (2)	–	–	<b>XS4P30AB110</b>
2-wire --- Output 4...20 mA (2)	<b>XS1M30AB120 (3)</b>	<b>XS4P30AB120</b>	–
Weight	kg 0.200	0.100	0.100

Characteristics			
Product certifications		cULus, CE, UKCA	
Connection		Pre-cabled, PvR 3 x 0.34 mm <sup>2</sup> , length 2 m	
Degree of protection Conforming to IEC 60529		IP 67	
Operating zone	mm	<b>1...10</b>	<b>1.5...15</b>
Repeat accuracy	%	± 3	
Linearity error	mA	± 2	± 1 V
Ambient air temperature	°C	For operation: - 25...+ 70	
Rated supply voltage	V	--- <b>12...24</b>	--- <b>24...48</b>
Voltage limits (including ripple)	V	--- 10...36	--- 15...58
Insulation class		Ⓜ	Ⓜ
Output current drift Ambient temperature: - 25...+ 70 °C	%	≤ 10	
Current consumption, no-load	mA	4	
Maximum operating rate	Hz	300	

(1) Voltage range only obtained with a load impedance of 1000 Ω.  
(2) Output current range Is, see page 82.  
(3) Add D at the end of reference for M12 connector version

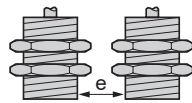
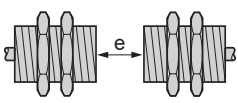
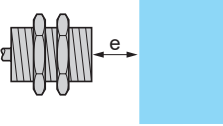
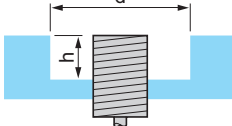
Setting-up				
Minimum mounting distances (mm)	Side by side	Face to face	Facing a metal object	Mounted in a metal support
				
<b>XS1M30AB120 flush mountable</b>	e ≥ 20	e ≥ 120	e ≥ 30	d ≥ 30, h ≥ 0
<b>XS4P30AB110 non-flush mountable</b>	e ≥ 60	e ≥ 180	e ≥ 45	d ≥ 90, h ≥ 30
<b>XS4P30AB120 non-flush mountable</b>	e ≥ 60	e ≥ 180	e ≥ 45	d ≥ 90, h ≥ 30
Fixing nut tightening torque	< 40 N.m (metal case), < 20 N.m (plastic case)			
Other versions	Please consult our Customer Care Centre.			

# Inductive proximity sensors

## XS range application

Sensors with analogue output signal 0...10 V (1)

For position, displacement and deformation control/monitoring

### Functions

These analogue output proximity sensors are solid-state sensors designed for monitoring displacement. They are not measuring sensors.

**They are suitable for use in many sectors, particularly for applications involving:**

- deformation and displacement monitoring,
- vibration amplitude and frequency monitoring,
- control of dimensional tolerances,
- position control,
- concentricity or eccentricity monitoring.

### Operating principle

The operating principle of the sensor is that of a damped oscillator. The degree of damping will depend on the distance of an object from the sensing face. The sensor will sense the distance and produce an output current with a value directly proportional to this distance.

### Output curves 0...10 V, 3-wire connection

#### XS9F

$S_n = 1 \dots 5 \text{ mm}$

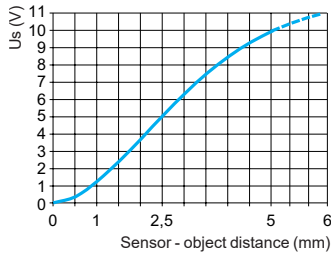

#### XS9E

$S_n = 1 \dots 10 \text{ mm}$

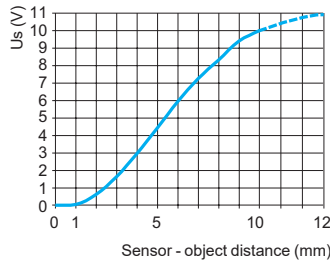

#### XS9C

$S_n = 2 \dots 15 \text{ mm}$

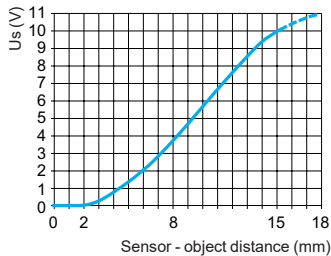

#### XS9D

$S_n = 5 \dots 40 \text{ mm}$

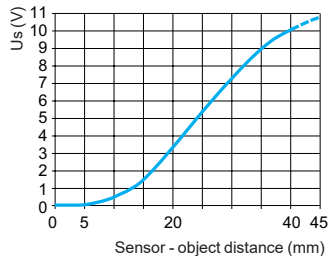

### Wiring schemes

#### Connector



#### Pre-cabled

BN: Brown  
BU: Blue  
BK: Black

#### 3-wire connection

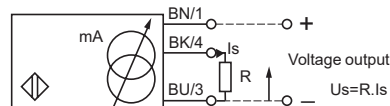

Output voltage	Output current	Load impedance value	Output voltage	Load impedance value
24 V	0...10 mA	$R \leq 1400 \Omega$	0...10 V	$R = 1000 \Omega$

**Note:** Ensure a minimum of 5 V between the + (terminal 1) and the sensor output (terminal 4).

(1) Voltage range only obtained with a load impedance of 1000  $\Omega$ .

# Inductive proximity sensors

## XS range application

Sensors with analogue output signal 0...10 V (1)

For position, displacement and deformation control/monitoring

Flush mountable in metal



PBT case



Nominal sensing distance (Sn)	mm	10	15
-------------------------------	----	----	----

### References

3-wire $\overline{\text{---}}$ 0...10 V	Pre-cabled (L = 2 m) (2)	<b>XS9E111A1L2</b>	<b>XS9C111A1L2</b>
Weight	kg	0.075	0.095

### Characteristics

Product certifications		cULus, CE, UKCA, ECOLAB
Connection	Pre-cabled	PvR 3 x 0.34 mm <sup>2</sup> , length 2 m for <b>XS9●111A●L2</b>
Operating zone	mm	<b>1...10</b>   <b>2...15</b>
Degree of protection Conforming to IEC 60529	Pre-cabled	IP 68
Storage temperature	°C	-40...+85
Operating temperature	°C	-25...+70
Materials		PBT case
Vibration resistance Conforming to IEC 60068-2-6		25 gn, amplitude ± 2 mm (f = 10 to 55 Hz)
Shock resistance Conforming to IEC 60068-2-27		50 gn, duration 11 ms
Output state indication		No
Rated supply voltage	V	$\overline{\text{---}}$ 24
Voltage limits (including ripple)		$\overline{\text{---}}$ 15...36
Insulation class		□
Repeat accuracy	%	± 3
Linearity error	V	± 1
Current consumption, no-load	mA	≤ 4 with overload and short-circuit protection
Maximum operating frequency	Hz	1000
Output current drift	%	≤ 10 (throughout the operating temperature range)

### Dimensions

XS9E/C

XS9C

XS9E

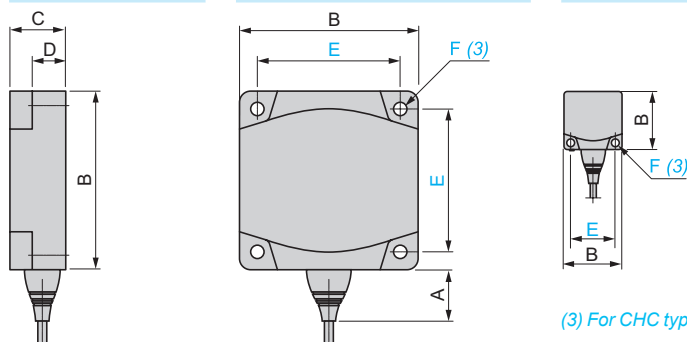

(3) For CHC type screws

Type	A (L2)	B	C	D	E	F
XS9E	14	26	13	8.8	20	3.5
XS9C	14	40	15	9.8	33	4.5

### Setting-up (Minimum mounting distances (mm))

Type	Side by side	Face to face	Facing a metal object
XS9E			
XS9C			

(1) Voltage range only obtained with a load impedance of 1000 Ω.

(2) For a 5 m long cable replace L2 by L5, for a 10 m long cable replace L2 by L10.

Example: XS9C111A1L2 becomes XS9C111A1L5 with a 5 m long cable.

# Inductive proximity sensors

## XS range application

Sensors with analogue output signal 4...20 mA

For position, displacement and deformation control/monitoring

### Functions

These analogue output proximity sensors are solid-state sensors designed for monitoring displacement. They are not measuring sensors.

**They are suitable for use in many sectors, particularly for applications involving:**

- deformation and displacement monitoring,
- vibration amplitude and frequency monitoring,
- control of dimensional tolerances,
- position control,
- concentricity or eccentricity monitoring.

### Operating principle

The operating principle of the sensor is that of a damped oscillator. The degree of damping will depend on the distance of an object from the sensing face. The sensor will sense the distance and produce an output current with a value directly proportional to this distance.

### Output curves 4...20 mA, 2-wire connection

#### XS9F

Sn = 1...5 mm

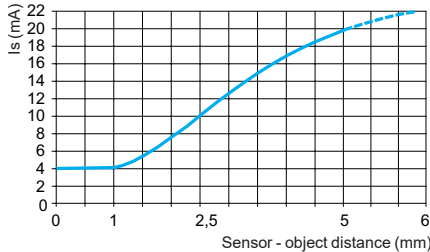

#### XS9E

Sn = 1...10 mm

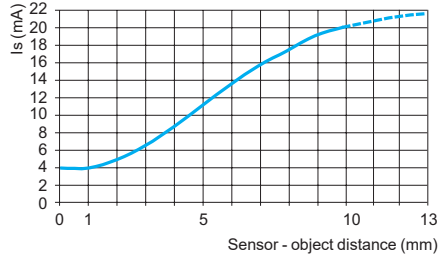

#### XS9C

Sn = 2...15 mm

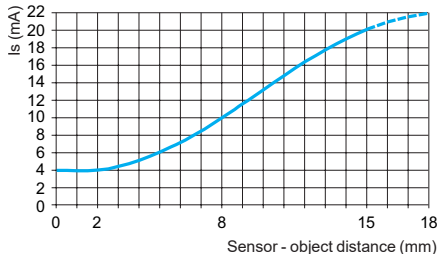

#### XS9D

Sn = 5...40 mm

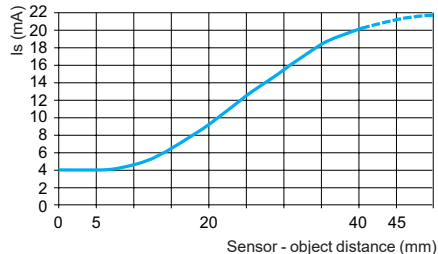

### Wiring schemes

#### Connector

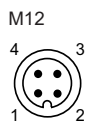
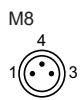

#### Pre-cabled

BN: Brown  
BU: Blue  
BK: Black

#### 2-wire connection

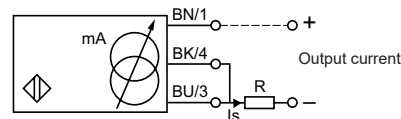

	Output current	Load impedance value
12 V	4...20 mA	$R \leq 8.2 \Omega$
24 V	4...20 mA	$R \leq 470 \Omega$

**Note:** Ensure a minimum of 10 V between the + (terminal 1) and - (terminal 3) of the sensor.

# Inductive proximity sensors

## XS range application

Sensors with analogue output signal 4...20 mA

For position, displacement and deformation control/monitoring

<b>Sensor type</b>	<b>Flush mountable in metal</b>
	<b>PBT case</b>



<b>Nominal sensing distance (Sn)</b>	<b>mm</b>	<b>10</b>	<b>15</b>	<b>40</b>
--------------------------------------	-----------	-----------	-----------	-----------

References					
2-wire $\overline{\text{---}}$	Pre-cabled (L = 2 m) (1)		<b>XS9E111A2L2</b>	<b>XS9C111A2L2</b>	<b>XS9D111A2L2</b>
4...20 mA	Connector		–	–	<b>XS9D111A2M12</b>
<b>Weight</b>	Pre-cabled (L = 2 m)	<b>kg</b>	0.075	0.095	0.340
	Connector	<b>kg</b>	–	–	0.320

Characteristics					
<b>Product certifications</b>			cULus, CE, UKCA, ECOLAB		
<b>Connection</b>	Pre-cabled		PvR 3 x 0.34 mm <sup>2</sup> , length 2 m		
	Connector				M12
<b>Operating zone</b>		<b>mm</b>	<b>1...10</b>	<b>2...15</b>	<b>5...40</b>
<b>Degree of protection</b>	Pre-cabled		IP 68		
	Connector		IP 67		
<b>Storage temperature</b>		<b>°C</b>	- 40...+ 85		
<b>Operating temperature</b>			- 25...+ 70		
<b>Materials</b>			PBT case		
<b>Vibration resistance</b>	Conforming to IEC 60068-2-6		25 gn, amplitude $\pm$ 2 mm (f = 10 to 55 Hz)		
<b>Shock resistance</b>	Conforming to IEC 60068-2-27		50 gn, duration 11 ms		
<b>Output state indication</b>			No		
<b>Rated supply voltage</b>		<b>V</b>	$\overline{\text{---}}$ 12...24		
<b>Voltage limits (including ripple)</b>		<b>V</b>	$\overline{\text{---}}$ 10...36		
<b>Insulation class</b>			$\square$	$\square$	$\square$
<b>Repeat accuracy</b>		<b>%</b>	$\pm$ 3		
<b>Linearity error</b>		<b>mA</b>	$\pm$ 2		
<b>Current consumption, no-load</b>		<b>mA</b>	$\leq$ 4 with overload and short-circuit protection		
<b>Maximum operating frequency</b>		<b>Hz</b>	1000		
<b>Output current drift</b>		<b>%</b>	$\leq$ 10 (throughout the operating temperature range)		

### Dimensions

	XS9E/C/D	XS9C/D	XS9E
--	----------	--------	------

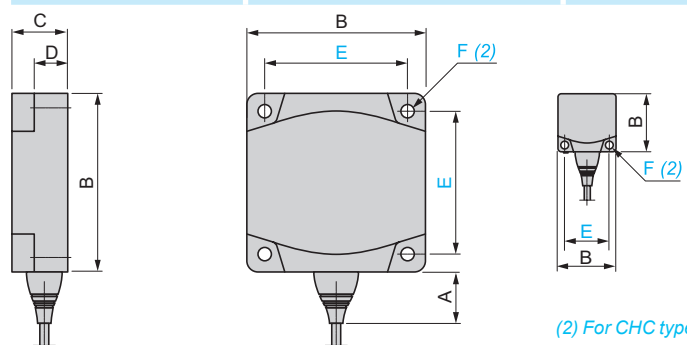

Type	A (L2)	A (M12)	B	C	D	E	F
XS9E	14	–	26	13	8.8	20	3.5
XS9C	14	–	40	15	9.8	33	4.5
XS9D	23	14	80	26	16	65	5.5

### Setting-up (Minimum mounting distances (mm))

Type	Side by side	Face to face	Facing a metal object
XS9E			
XS9C	$e \geq 30$	$e \geq 72$	$e \geq 30$
XS9D	$e \geq 45$	$e \geq 110$	$e \geq 45$
	$e \geq 120$	$e \geq 300$	$e \geq 120$

(1) For a 5 m long cable replace L2 by L5; for a 10 m long cable replace L2 by L10.  
Example: XS9E111A2L2 becomes XS9E111A2L5 with a 5 m long cable.

# Inductive proximity sensors

## XS range application

Sensors with analogue output signal 0...10 V <sup>(1)</sup> or 4...20 mA. Plastic case, 40 x 40 mm front face  
5-position turret head

<b>Sensor type</b>	Non-flush mountable in metal		
<b>Dimensions</b>	mm	40 x 40 x 70	40 x 40 x 117



<b>Nominal sensing distance (Sn)</b>	mm	25
--------------------------------------	----	----

### References

<b>3-wire ---</b>	0...10 V output <sup>(1)</sup>	<b>XS9C2A2A1M12</b>	—
<b>2-wire ---</b>	4...20 mA output	<b>XS9C2A2A2M12</b>	<b>XS9C4A2A2P20</b> <sup>(2)</sup>
<b>XS9C4...P20</b> sensors are available with an ISO M20 cable entry and can be supplied with a PG 13.5 (e.g. <b>XS9C4A2A1G13</b> ) or a 1/2" NPT (e.g. <b>XS9C4A2A2N12</b> ) cable entry: please consult our Customer Care Centre for more information.			
<b>Weight</b>	kg	0.149	0.244

### Characteristics

<b>Product certifications</b>	cULus, CE, UKCA		
<b>Conformity to standards</b>	IEC 60947-5-2 and IEC 60947-5-7		
<b>Connection</b>	M12 connector (4-pin)		Screw terminals, clamping capacity 3 x 1.5 mm <sup>2</sup> / 3 x 16 AWG
<b>Operating zone</b>	mm	2...27	
<b>Linearity error</b>	%	< 3	
<b>Repeat accuracy</b>	%	< 3	
<b>Output current drift</b>	%	< 5	
<b>Degree of protection</b>	Conforming to IEC 60529 and DIN 40050	IP 65, IP 67 and IP 69K	
<b>Temperature</b>	Storage	°C	- 40...+ 85
	Operation <sup>(3)</sup>	°C	- 25...+ 70
<b>Material</b>	Case	PBT	
<b>Vibration resistance</b>	Conforming to IEC 60068-2-6	25 gn, amplitude ± 2 mm (f = 10...55 Hz)	
<b>Shock resistance</b>	Conforming to IEC 60068-2-27	50 gn for 11 ms	
<b>Indicators</b>	Output state (alignment aid)	Yellow LED	
<b>Rated supply voltage</b>	4...20 mA	V	--- 12...24 with protection against reverse polarity
	0...10 V	V	--- 24 with protection against reverse polarity
<b>Voltage limits (including ripple)</b>	4...20 mA	V	--- 12...36
	0...10 V	V	--- 15...36
<b>Insulation class</b>	□		
<b>Current consumption, no-load</b>	3-wire ---	mA	< 4
<b>Delays</b>	First-up	ms	< 7
	Response	ms	< 6
	Recovery	ms	< 6

### Analogue outputs 4-20 mA and 0-10 V

<b>XS9C2A2A2M12 and XS9C4A2A2P20</b>	<b>XS9C2A2A1M12</b>
--------------------------------------	---------------------

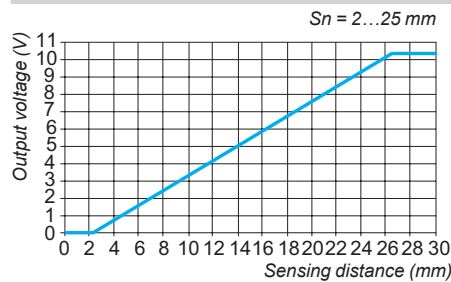
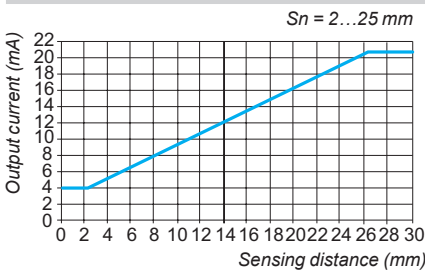

(1) Voltage range only obtained with a load impedance of 1000 Ω.  
 (2) These sensors are supplied without a cable gland. An adaptable PG 13.5 cable gland is available (reference **XSZPE13**).  
 (3) Sensors are available for very low temperatures (suffix **TF**: - 40°C, + 70°C) or very high temperatures (suffix **TT**: - 25°C, + 85°C); please consult our Customer Care Centre.



# Inductive proximity sensors

## XS range application

Cylindrical, stainless steel 316L front face for food and beverage applications and harsh industrial environments. Three-wire DC, solid-state output



XS912●1PAM12



XS918●1PAM12



XS930●1PAM12



XSZBS30



XUZA118



XZCPA1241L●



XZCP1141L●

### Ø 12 mm, threaded M12 x 1

Sensing distance (Sn) mm	Function	Output	Connection	Reference	Weight (kg)
<b>Three-wire 12-24V DC, flush mountable</b>					
6	NO	PNP	M12	XS912S1PAM12	0.024

### Three-wire 12-24V DC, non-flush mountable

10	NO	PNP	M12	XS912S4PAM12	0.023
----	----	-----	-----	--------------	-------

### Ø 18 mm, threaded M18 x 1

Sensing distance (Sn) mm	Function	Output	Connection	Reference	Weight (kg)
<b>Three-wire 12-24V DC, flush mountable</b>					
10	NO	PNP	M12	XS918S1PAM12	0.051

### Three-wire 12-24V DC, non-flush mountable

20	NO	PNP	M12	XS918S4PAM12	0.051
----	----	-----	-----	--------------	-------

### Ø 30 mm, threaded M30 x 1.5

Sensing distance (Sn) mm	Function	Output	Connection	Reference	Weight (kg)
<b>Three-wire 12-24V DC, flush mountable</b>					
20	NO	PNP	M12	XS930S1PAM12	0.140

### Three-wire 12-24V DC, non-flush mountable

40	NO	PNP	M12	XS930S4PAM12	0.145
----	----	-----	-----	--------------	-------

### Accessories

Description	For use with sensors (mm)	Reference	Weight (kg)
Fixing clamps	Ø 12	XSZBS12	0.090
	Ø 18	XUZA118	0.190
	Ø 30	XSZBS30	0.370

### Connecting cables (PVC) (1)

Description	Type	Length m	Reference	Weight (kg)
Pre-wired M12 connectors Female, 4-pin Stainless steel clamping ring	Straight	2	XZCPA1141L2	0.090
		5	XZCPA1141L5	0.190
		10	XZCPA1141L10	0.370
	Elbowed	2	XZCPA1241L2	0.090
		5	XZCPA1241L5	0.190
		10	XZCPA1241L10	0.370

### Wiring schemes

#### M12 connector



#### PNP

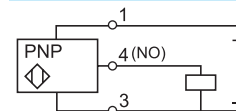

(1) For further information, please consult our site [www.telemecaniquesensors.com](http://www.telemecaniquesensors.com).

# Inductive proximity sensors

## XS range application

Cylindrical, stainless steel 316L front face  
for food and beverage applications and harsh industrial  
environments. Three-wire DC, solid-state output

Characteristics					
Sensor type	Flush		XS912S1PAM12	XS918S1PAM12	XS930S1PAM12
	Non-flush		XS912S4PAM12	XS918S4PAM12	XS930S4PAM12
Product certifications			cULus, CE, UKCA, ECOLAB		
Connection	Connector		M12		
Operating zone	Flush	mm	0...4.8	0...8	0...16
	Non-flush	mm	0...8	0...16	0...32
Differential travel		%	1...15 (real sensing distance Sr)		
Degree of protection	Conforming to IEC 60529		IP 68 (5 meters underwater for 1 month)		
	Conforming to DIN 40050		IP 69K		
Storage temperature		°C	-25...+85 (-13...185°F)		
Operating temperature		°C	-25...+85 (-13...185°F)		
Materials	Case		Stainless steel 316L		
Front face thickness		mm	0.4	0.6	1.0
Mechanical shock resistance	Conforming to IEC 62262		IK10		
Vibration resistance	Conforming to IEC 60068-2-6		25 gn, amplitude ± 1 mm (f = 10 to 55 Hz)		
Shock resistance	Conforming to IEC 60068-2-27		30 gn, duration 11 ms		
Output state indication			Yellow LED, 4 viewing points at 90° (blinking from 0.8 Sr and Sr)		
Rated supply voltage		V	12...24 with protection against reverse polarity		
Voltage limits (including ripple)		V	10...30		
Insulation class			□		
Switching capacity		mA	≤ 200 with overload and short-circuit protection		
Voltage drop, closed state		V	≤ 2		
Current consumption, no-load		mA	≤ 10		
Maximum switching frequency	Flush	Hz	600	300	100
	Non-flush	Hz	400	200	90
Delays	First set-up	ms	40		
	Response	µs	0.06		
	Recovery	µs	15		

## Setting-up

### Minimum mounting distances in mm, flush version

Side by side		Face to face	Facing a metal object	Mounted in a metal support
Ø 12	e ≥ 38	e ≥ 30	e ≥ 20	d ≥ 24
Ø 18	e ≥ 42	e ≥ 40	e ≥ 30	d ≥ 50
Ø 30	e ≥ 80	e ≥ 70	e ≥ 60	d ≥ 90

### Minimum mounting distances in mm, non-flush version

Side by side		Face to face	Facing a metal object	Mounted in a metal support
Ø 12	e ≥ 108	e ≥ 40	e ≥ 30	d ≥ 30 h ≥ 22
Ø 18	e ≥ 182	e ≥ 70	e ≥ 60	d ≥ 60 h ≥ 34
Ø 30	e ≥ 270	e ≥ 130	e ≥ 120	d ≥ 120 h ≥ 34

## Dimensions

	Flush sensor			Non-flush sensor		
	M12	M18	M30	M12	M18	M30
a (mm)	60	63.5	63.5	60	63.5	63.5
b (mm)	41	42	42	36	35	32
c (mm)	0	0	0	5	7	10

## Reduction coefficient

Flush-non mounted		Flush sensor			Non-flush sensor		
		M12	M18	M30	M12	M18	M30
Steel		1	1	1	1	1	1
Aluminum		1	1	1	1	1	1
Brass		1.3	1.2	1.3	1.4	1.35	1.2
Copper		0.85	0.8	0.9	0.8	0.9	0.9
Stainless steel	Thickness 1 mm	0.5	0.5	0.35	(1)	0.3	(1)
	Thickness 2 mm	0.9	0.9	0.7	0.66	0.6	0.25
Flush mounted		M12	M18	M30	(1) No detection.		
Steel		0.7	0.75	0.9			
Aluminum		1.15	0.9	0.7			
Brass		1.05	0.75	0.6			
Stainless steel		0.8	0.8	1.3			

# Inductive proximity sensors

XS range application

Food and beverage processing series

Cylindrical, stainless steel, non-flush mountable

Three-wire DC, solid-state output



XS2●●SA●●L2



XS2●●SA●●M12



XS230SA●●L2



XSZBS●●



XUZA118



XZCPA1241L●



XZCP1141L●

## Ø 12, threaded M12 x 1

Sensing distance (Sn) mm	Function	Output	Connection	Reference	Weight (kg)
7	NO	PNP	Pre-cabled (L = 2 m) (1)	<b>XS212SAPAL2</b>	0.075
			M12 connector	<b>XS212SAPAM12</b>	0.035
			Pre-cabled (L = 2 m) (1)	<b>XS212SANAL2</b>	0.075
			M12 connector	<b>XS212SANAM12</b>	0.035

## Ø 18, threaded M18 x 1

Sensing distance (Sn) mm	Function	Output	Connection	Reference	Weight (kg)
12	NO	PNP	Pre-cabled (L = 2 m) (1)	<b>XS218SAPAL2</b>	0.120
			M12 connector	<b>XS218SAPAM12</b>	0.060
			Pre-cabled (L = 2 m) (1)	<b>XS218SANAL2</b>	0.120
			M12 connector	<b>XS218SANAM12</b>	0.060

## Ø 30, threaded M30 x 1.5

Sensing distance (Sn) mm	Function	Output	Connection	Reference	Weight (kg)
22	NO	PNP	Pre-cabled (L = 2 m) (1)	<b>XS230SAPAL2</b>	0.205
			M12 connector	<b>XS230SAPAM12</b>	0.145
			Pre-cabled (L = 2 m) (1)	<b>XS230SANAL2</b>	0.205
			M12 connector	<b>XS230SANAM12</b>	0.145

## Accessories (2)

Description	For use with sensor (mm)	Reference	Weight (kg)
Stainless steel fixing bracket	Ø 12	<b>XSZBS12</b>	0.060
	Ø 18	<b>XUZA118</b>	0.045
	Ø 30	<b>XSZBS30</b>	0.080

## Connecting cables

Description	Type	Length m	Reference	Weight (kg)
Pre-wired M12 connectors Female, 4-pin, stainless steel clamping ring	Straight	2	<b>XZCPA1141L2</b>	0.090
		5	<b>XZCPA1141L5</b>	0.210
		10	<b>XZCPA1141L10</b>	0.410
	Elbowed	2	<b>XZCPA1241L2</b>	0.090
		5	<b>XZCPA1241L5</b>	0.210
		10	<b>XZCPA1241L10</b>	0.410
M12 jumper cable Male, 3-pin, stainless steel clamping ring	Straight	2	<b>XZCRA151140A2</b>	0.095
		5	<b>XZCRA151140A5</b>	0.200

(1) For a 5 m long cable replace L2 by L5; for a 10 m long cable replace L2 by L10.

Example: **XS212SAPAL2** becomes **XS212SAPAL5** with a 5 m long cable.

(2) For further information, see page 120.

Characteristics		XS2●●SA●●M12	XS2●●SA●●L2
Sensor type		cULus, CE, UKCA	
Product certifications/approvals		M12	
Connection	Connector	-	
	Pre-cabled	Length: 2 m	
Operating zone	Ø 12	mm	0...5.6
	Ø 18	mm	0...9.6
	Ø 30	mm	0...17.6
Differential travel		%	
Degree of protection		1...15 of effective sensing distance (Sr)	
Storage temperature	Conforming to IEC 60529	IP 67	
	DIN 40050	IP 69K	
Operating temperature		°C	
Materials		-40...+85 (1)	
Vibration resistance	Case	Stainless steel 316 L	
	Cable	-	
Shock resistance		Non-poisonous PVC, 3 x 0.34 mm <sup>2</sup>	
Output state indication		25 gn, amplitude ± 2 mm (f = 10 to 55 Hz)	
Rated supply voltage		50 gn, duration 11 ms	
Voltage limits (including ripple)		Yellow LED: 4 viewing ports at 90°	
Insulation class		Yellow LED: annular	
Switching capacity		V	
Voltage drop, closed state		--- 12...24 with protection against reverse polarity	
Current consumption, no-load		V	
Maximum switching frequency		--- 10...36	
Delays	First-up	mA	
	Response	≤ 200 with overload and short-circuit protection	
	Recovery	V	
Materials		≤ 2	
Switching capacity		mA	
Voltage drop, closed state		≤ 10	
Current consumption, no-load		Hz	
Maximum switching frequency		2500	
Materials		Hz	
Switching capacity		1000	
Voltage drop, closed state		Hz	
Current consumption, no-load		500	
Maximum switching frequency		ms	
Materials		≤ 10	
Switching capacity		ms	
Voltage drop, closed state		≤ 0.2 Ø 12, ≤ 0.3 Ø 18, ≤ 0.6 Ø 30	
Current consumption, no-load		ms	
Maximum switching frequency		≤ 0.2 Ø 12, ≤ 0.7 Ø 18, ≤ 1.4 Ø 30	

(1) + 100 °C for cleaning and sterilization phases whilst not in service.

## Wiring schemes

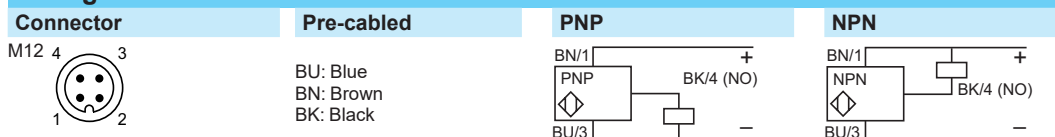

## Setting-up

### Minimum mounting distances (mm)

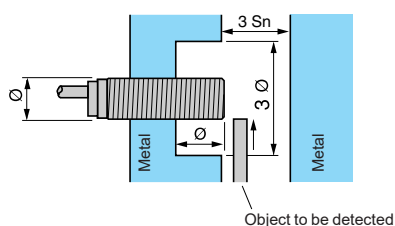

	Side by side	Face to face	Facing a metal object
Ø 12	e ≥ 48	e ≥ 84	e ≥ 21
Ø 18	e ≥ 72	e ≥ 144	e ≥ 36
Ø 30	e ≥ 120	e ≥ 264	e ≥ 66

## Dimensions

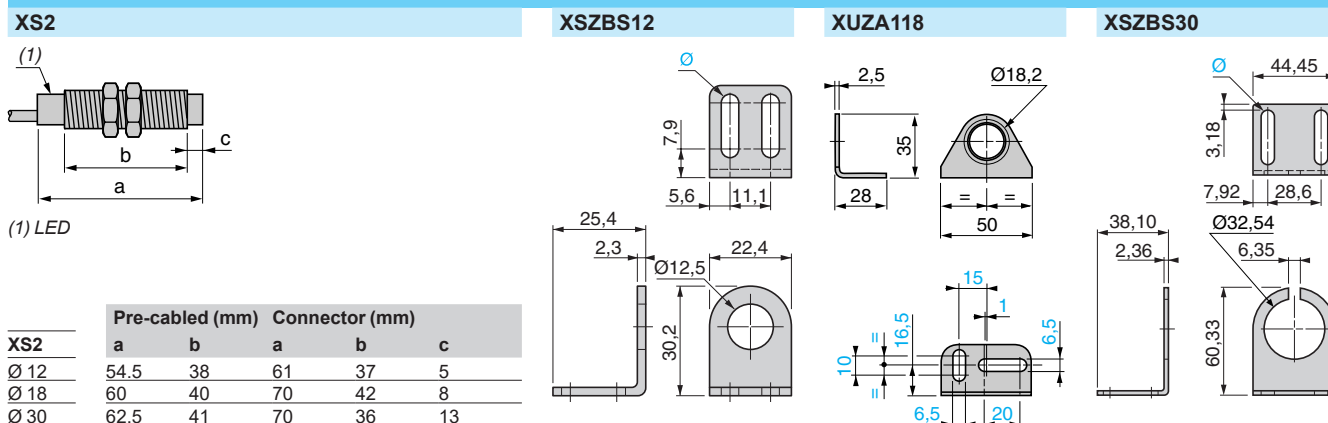

Ø: 2 elongated holes Ø 4.8 x 12.7

# Inductive proximity sensors

XS range application

Food and beverage processing series

Cylindrical, stainless steel, non-flush mountable

Two-wire AC or DC



XS218SAM●L2



XS218SAMAU20



XS230SAM●L2



XS230SAM●U20

### Ø 18, threaded M18 x 1

Sensing distance (Sn) mm	Function	Connection	Reference	Weight (kg)
12	NO	Pre-cabled (L = 2 m) (1)	<b>XS218SAMAL2</b>	0.120
		1/2"-20UNF connector	<b>XS218SAMAU20</b>	0.060

### Ø 30, threaded M30 x 1.5

Sensing distance (Sn) mm	Function	Connection	Reference	Weight (kg)
22	NO	Pre-cabled (L = 2 m) (1)	<b>XS230SAMAL2</b>	0.205
		1/2"-20UNF connector	<b>XS230SAMAU20</b>	0.145

### Connecting cables

Description	Type	Length m	Reference	Weight (kg)
Pre-wired connectors 1/2"-20UNF 3-pin female, stainless steel clamping ring	Straight	5	<b>XZCPA1865L5</b>	0.210
		10	<b>XZCPA1865L10</b>	0.410
	Elbowed	5	<b>XZCPA1965L5</b>	0.250
		10	<b>XZCPA1965L10</b>	0.485

### Accessories

Description	For use with sensors (mm)	Reference	Weight (kg)
Stainless steel fixing brackets	Ø 18	<b>XUZA118</b>	0.045
	Ø 30	<b>XSZBS30</b>	0.080



XSZBS30



XUZA118

(1) For a 5 m long cable replace L2 by L5; for a 10 m long cable replace L2 by L10.  
Example: XS218SAMAL2 becomes XS218SAMAL5 with a 5 m long cable.

Characteristics		XS2●●SAM●U20	XS2●●SAM●L2
Sensor type		XS2●●SAM●U20	
Product certifications/approvals		cULus, CE, UKCA	
Connection	Connector	1/2"-20UNF	–
	Pre-cabled	–	Length: 2 m
Operating zone	∅ 18	<b>mm 0...9.6</b>	
	∅ 30	<b>mm 0...17.6</b>	
Differential travel		%	
		1...15 of effective sensing distance (Sr)	
Degree of protection	Conforming to IEC 60529	IP 67	IP 68
	DIN 40050	IP 69K	
Storage temperature		°C	
		- 40...+ 85 (1)	
Operating temperature		°C	
		- 25...+ 85	
Materials	Case	Stainless steel 316 L	
	Cable	–	Non-poisonous PVC, 2 x 0.34 mm <sup>2</sup>
Vibration resistance		Conforming to IEC 60068-2-6	
		25 gn, amplitude ± 2 mm (f = 10 to 55 Hz)	
Shock resistance		Conforming to IEC 60068-2-27	
		50 gn, duration 11 ms	
Output state indication		Yellow LED: 4 viewing ports at 90°	Yellow LED: annular
Rated supply voltage		V	
		~ or --- 24...240 (~ 50/60 Hz)	
Voltage limits (including ripple)		V	
		~ or --- 20...264	
Insulation class		I	
Switching capacity		mA	
		~ 5...300 or --- 5...200 (2)	
Voltage drop, closed state		V	
		≤ 5.5	
Residual current, open state		mA	
		≤ 0.8	
Maximum switching frequency	XS218SAM●●●	Hz	
	XS230SAM●●●	Hz	
Delays	First-up	ms	
	Response	ms	
	Recovery	ms	

(1) + 100 °C for cleaning and sterilization phases whilst not in service.  
(2) It is essential to connect a 0.4 A "quick-blow" fuse in series with the load.

## Wiring schemes

Connector	Pre-cabled	2-wire ~ or ---
1/2"-20UNF	BU: Blue BN: Brown	<b>NO output</b>
AC/DC: 2 ±: 1 AC/DC: 3		±: on connector models only

## Setting-up

### Minimum mounting distances (mm)

Mounting Type	∅ 18	∅ 30
Side by side	e ≥ 72	e ≥ 120
Face to face	e ≥ 144	e ≥ 264
Facing a metal object	e ≥ 36	e ≥ 66

## Dimensions

XS2	XSZA118	XSZBS30
(1) LED		

XS2	Pre-cabled (mm)		Connector (mm)		
	a	b	a	b	c
∅ 18	60	40	72	44	8
∅ 30	62.5	41	74	40	13

Ø: 2 elongated holes Ø 7.14 x 29.36

# Inductive proximity sensors

XS range application

Food and beverage processing series

Cylindrical, plastic, non-flush mountable

Three-wire DC, solid-state output



XS2●●AA●●L2



XS2●●AA●●M12



XS230AA●●L2



XSZB1●●



XZCPA1241L●



XZCP1141L●

## Ø 12, threaded M12 x 1

Sensing distance (Sn) mm	Function	Output	Connection	Reference	Weight (kg)
7	NO	PNP	Pre-cabled (L = 2 m) (1)	<b>XS212AAPAL2</b>	0.065
			M12 connector	<b>XS212AAPAM12</b>	0.030
	NPN	PNP	Pre-cabled (L = 2 m) (1)	<b>XS212AANAL2</b>	0.065
			M12 connector	<b>XS212AANAM12</b>	0.030

## Ø 18, threaded M18 x 1

Sensing distance (Sn) mm	Function	Output	Connection	Reference	Weight (kg)
12	NO	PNP	Pre-cabled (L = 2 m) (1)	<b>XS218AAPAL2</b>	0.100
			M12 connector	<b>XS218AAPAM12</b>	0.040
	NPN	PNP	Pre-cabled (L = 2 m) (1)	<b>XS218AANAL2</b>	0.100
			M12 connector	<b>XS218AANAM12</b>	0.040

## Ø 30, threaded M30 x 1.5

Sensing distance (Sn) mm	Function	Output	Connection	Reference	Weight (kg)
22	NO	PNP	Pre-cabled (L = 2 m) (1)	<b>XS230AAPAL2</b>	0.140
			M12 connector	<b>XS230AAPAM12</b>	0.080
	NPN	PNP	Pre-cabled (L = 2 m) (1)	<b>XS230AANAL2</b>	0.140
			M12 connector	<b>XS230AANAM12</b>	0.080

## Accessories (2)

Description	For use with sensors (mm)	Reference	Weight (kg)
Fixing clamps	Ø 12	<b>XSZB112</b>	0.006
	Ø 18	<b>XSZB118</b>	0.010
	Ø 30	<b>XSZB130</b>	0.020

## Connecting cables

Description	Type	Length m	Reference	Weight (kg)
<b>Pre-wired M12 connectors</b> Female, 4-pin, stainless steel clamping ring	Straight	2	<b>XZCPA1141L2</b>	0.090
		5	<b>XZCPA1141L5</b>	0.190
		10	<b>XZCPA1141L10</b>	0.370
	Elbowed	2	<b>XZCPA1241L2</b>	0.090
		5	<b>XZCPA1241L5</b>	0.190
		10	<b>XZCPA1241L10</b>	0.370
<b>M12 jumper cable</b> Male, 3-pin, stainless steel clamping ring	Straight	2	<b>XZCRA151140A2</b>	0.090
		5	<b>XZCRA151140A5</b>	0.190

(1) For a 5 m long cable replace L2 by L5; for a 10 m long cable replace L2 by L10.  
Example: **XS212AAPAL2** becomes **XS212AAPAL5** with a 5 m long cable.

(2) For further information, see page 120.

# Inductive proximity sensors

XS range application

Food and beverage processing series

Cylindrical, plastic, non-flush mountable

Three-wire DC, solid-state output

Characteristics		XS2●●AA●●M12	XS2●●AA●●L2
Sensor type		cULus, CE, UKCA	
Product certifications/approvals		cULus, CE, UKCA	
Connection	Connector	M12	–
	Pre-cabled	–	Length: 2 m
Operating zone	Ø 12	mm	0...5.6
	Ø 18	mm	0...9.6
	Ø 30	mm	0...17.6
Differential travel	%	1...15 of effective sensing distance (Sr)	
Degree of protection	Conforming to IEC 60529	IP 67	IP 68
	DIN 40050	IP 69K	–
Storage temperature	°C	- 40...+ 85	
Operating temperature	°C	- 25...+ 85	
Materials	Case	PPS	
	Cable	–	PvR and 3 x 0.34 mm <sup>2</sup>
Vibration resistance	Conforming to IEC 60068-2-6	25 gn, amplitude ± 2 mm (f = 10 to 55 Hz)	
Shock resistance	Conforming to IEC 60068-2-27	50 gn, duration 11 ms	
Output state indication		Yellow LED: annular	
Rated supply voltage	V	~ 12...48 for T - 25...+ 85 °C	
Voltage limits (including ripple)	V	~ 10...58 for T - 25...+ 85 °C	
Insulation class		□ □	
Switching capacity	mA	≤ 200 with overload and short-circuit protection	
Voltage drop, closed state	V	≤ 2	
Current consumption, no-load	mA	≤ 10	
Maximum switching frequency	XS212AA●●●●	Hz	2500
	XS218AA●●●●	Hz	1000
	XS230AA●●●●	Hz	500
Delays	First-up	ms	≤ 10
	Response	ms	≤ 0.2 Ø 12, ≤ 0.3 Ø 18, ≤ 0.6 Ø 30
	Recovery	ms	≤ 0.2 Ø 12, ≤ 0.7 Ø 18, ≤ 1.4 Ø 30

## Wiring schemes

Connector	Pre-cabled	PNP	NPN
M12 4 3 1 2	BU: Blue BN: Brown BK: Black		

## Setting-up

	Minimum mounting distances (mm)		
	Side by side	Face to face	Facing a metal object
Ø 12	e ≥ 48	e ≥ 84	e ≥ 21
Ø 18	e ≥ 72	e ≥ 144	e ≥ 36
Ø 30	e ≥ 120	e ≥ 264	e ≥ 66

## Dimensions

	XS2			
	Pre-cabled (mm)		Connector (mm)	
Ø 12	a	b	a	b
Ø 12	50	42	61	43
Ø 18	60	51	70	52
Ø 30	60	51	70	52

# Inductive proximity sensors

XS range application

Food and beverage processing series

Cylindrical, plastic, non-flush mountable

Two-wire AC or DC



XS218AAM L2



XS230AAM U20



XS230AAM L2



XSZB118

Ø 18, threaded M18 x 1				
Sensing distance (Sn) mm	Function	Connection	Reference	Weight (kg)
12	NO	Pre-cabled (L = 2 m) (1)	XS218AAMAL2	0.100
		1/2"-20UNF connector	XS218AAMAU20	0.040

Ø 30, threaded M30 x 1.5				
Sensing distance (Sn) mm	Function	Connection	Reference	Weight (kg)
22	NO	Pre-cabled (L = 2 m) (1)	XS230AAMAL2	0.140
		1/2"-20UNF connector	XS230AAMAU20	0.080

Accessories (2)			
Description	For use with sensors (mm)	Reference	Weight (kg)
Fixing clamps	Ø 18	XSZB118	0.010
	Ø 30	XSZB130	0.020

Connecting cables				
Description	Type	Length m	Reference	Weight (kg)
Pre-wired connectors 1/2"-20UNF 3-pin female, stainless steel	Straight	5	XZCPA1865L5	0.180
		10	XZCPA1865L10	0.350
316 L clamping ring	Elbowed	5	XZCPA1965L5	0.180
		10	XZCPA1965L10	0.350

(1) For a 5 m long cable replace L2 by L5; for a 10 m long cable replace L2 by L10.

Example: XS218AAMAL2 becomes XS218AAMAL5 with a 5 m long cable.

(2) For further information, see page 120.

Characteristics		XS2●●AAM●U20	XS2●●AAM●L2
Sensor type		cULus, CE, UKCA	
Product certifications/approvals		cULus, CE, UKCA	
Connection	Connector	1/2"-20UNF	–
	Pre-cabled	–	Length: 2 m
Operating zone	Ø 18	<b>mm 0...9.6</b>	
	Ø 30	<b>mm 0...17.6</b>	
Differential travel		%	
Degree of protection		1...15 of effective sensing distance (Sr)	
Storage temperature	Conforming to IEC 60529	IP 67	IP 68
	DIN 40050	IP 69K	
Operating temperature		°C	
Materials		°C	
Case		-40...+85	
Cable		-25...+85	
Materials		PPS	
Vibration resistance		–	
Conforming to IEC 60068-2-6		PvR and 2 x 0.34 mm <sup>2</sup>	
Shock resistance		25 gn, amplitude ± 2 mm (f = 10 to 55 Hz)	
Conforming to IEC 60068-2-27		50 gn, duration 11 ms	
Output state indication		Yellow LED: annular	
Rated supply voltage		V	
Voltage limits (including ripple)		~ or --- 24...240 (~ 50/60 Hz)	
Insulation class		V	
Switching capacity		~ or --- 20...264	
Voltage drop, closed state		I	
Residual current, open state		mA	
Maximum switching frequency		~ 5...300 or --- 5...200 (1)	
First-up		V	
Response		≤ 5.5	
Recovery		mA	
First-up		≤ 0.8	
Response		Hz	
Recovery		~ 25 or --- 1000	
First-up		Hz	
Response		~ 25 or --- 300	
Recovery		ms	
First-up		≤ 30	
Response		ms	
Recovery		≤ 0.5	
First-up		ms	
Response		≤ 0.5 XS218AAM●●●, ≤ 2 XS230AAM●●●	
Recovery		ms	
First-up		≤ 0.5 XS218AAM●●●, ≤ 2 XS230AAM●●●	
Response		ms	
Recovery		ms	

(1) It is essential to connect a 0.4 A "quick-blow" fuse in series with the load.

## Wiring schemes

Connector	Pre-cabled	2-wire ~ or ---
1/2"-20UNF	BU: Blue BN: Brown	NO output

## Setting-up

Minimum mounting distances (mm)	
Ø 18	e ≥ 72
Ø 30	e ≥ 120
	Side by side
Ø 18	e ≥ 72
Ø 30	e ≥ 120
	Face to face
Ø 18	e ≥ 144
Ø 30	e ≥ 264
	Facing a metal object
Ø 18	e ≥ 36
Ø 30	e ≥ 66

## Dimensions

### XS2

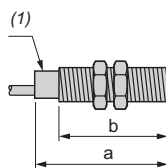

(1) LED

XS2	Pre-cabled (mm)		Connector (mm)	
	a	b	a	b
Ø 18	60	51	70	52
Ø 30	60	51	70	52

# Inductive proximity sensors

XS range application

Cylindrical, stainless steel 303 front face

for harsh industrial environments

Three-wire DC, solid-state output



XS908●1PAM12



XS912●1PAM12



XS918●1PAM12



XS930●1PAM12



XZCPA1241L●



XZCP1141L●

## Ø 8 mm, threaded M8 x 1

Sensing distance (Sn) mm	Function	Output	Connection	Reference	Weight (kg)
<b>Three-wire 12-24V <math>\overline{DC}</math>, flush mountable</b>					
3	NO	PNP	M12	XS908R1PAM12	0.018

## Three-wire 12-24V $\overline{DC}$ , non-flush mountable

6	NO	PNP	M12	XS908R4PAM12	0.018
---	----	-----	-----	--------------	-------

## Ø 12 mm, threaded M12 x 1

Sensing distance (Sn) mm	Function	Output	Connection	Reference	Weight (kg)
<b>Three-wire 12-24V <math>\overline{DC}</math>, flush mountable</b>					
6	NO	PNP	M12	XS912R1PAM12	0.024

## Three-wire 12-24V $\overline{DC}$ , non-flush mountable

10	NO	PNP	M12	XS912R4PAM12	0.023
----	----	-----	-----	--------------	-------

## Ø 18 mm, threaded M18 x 1

Sensing distance (Sn) mm	Function	Output	Connection	Reference	Weight (kg)
<b>Three-wire 12-24V <math>\overline{DC}</math>, flush mountable</b>					
10	NO	PNP	M12	XS918R1PAM12	0.044

## Three-wire 12-24V $\overline{DC}$ , non-flush mountable

20	NO	PNP	M12	XS918R4PAM12	0.051
----	----	-----	-----	--------------	-------

## Ø 30 mm, threaded M30 x 1.5

Sensing distance (Sn) mm	Function	Output	Connection	Reference	Weight (kg)
<b>Three-wire 12-24V <math>\overline{DC}</math>, flush mountable</b>					
20	NO	PNP	M12	XS930R1PAM12	0.140

## Three-wire 12-24V $\overline{DC}$ , non-flush mountable

40	NO	PNP	M12	XS930R4PAM12	0.144
----	----	-----	-----	--------------	-------

## Connecting cables (PUR) (1)

Description	Type	Length m	Reference	Weight (kg)
Pre-wired M12 connectors Female, 4-pin Metal clamping	Straight	2	XZCP1141L2	0.090
		5	XZCP1141L5	0.190
		10	XZCP1141L10	0.370
	Elbowed	2	XZCP1241L2	0.090
		5	XZCP1241L5	0.190
		10	XZCP1241L10	0.370

## Wiring schemes

### M12 connector



### PNP

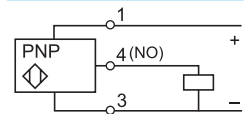

(1) For further information, please consult our site [www.telemecaniquesensors.com](http://www.telemecaniquesensors.com).

# Inductive proximity sensors

XS range application

Cylindrical, stainless steel 303 front face

for harsh industrial environments

Three-wire DC, solid-state output

Characteristics						
Sensor type	Flush		XS908R1PAM12	XS912R1PAM12	XS918R1PAM12	XS930R1PAM12
	Non-flush		XS908R4PAM12	XS912R4PAM12	XS918R4PAM12	XS930R4PAM12
Product certifications			cULus, CE, UKCA			
Connection	Connector		M12			
Operating zone	Flush	mm	0...2.4	0...4.8	0...8	0...16
	Non-flush	mm	0...4.8	0...8	0...16	0...32
Differential travel		%	1...15 (real sensing distance Sr)			
Degree of protection	Conforming to IEC 60529		IP 67	IP 68 (5 meters underwater for 1 month)		
	Conforming to DIN 40050		IP 69K			
Storage temperature		°C	-25...+70 (-13...158°F)			
Operating temperature		°C	-25...+70 (-13...158°F)			
Materials	Case		Stainless steel, 303 grade			
Front face thickness		mm	0.25	0.4	0.6	1.0
Mechanical shock resistance	Conforming to IEC 62262		IK10			
Vibration resistance	Conforming to IEC 60068-2-6		25 gn, amplitude ± 1 mm (f = 10 to 55 Hz)			
Shock resistance	Conforming to IEC 60068-2-27		30 gn, duration 11 ms			
Output state indication			Yellow LED, 4 viewing points at 90° (blinking from 0.8 Sr and Sr)			
Rated supply voltage		V	12...24 with protection against reverse polarity			
Voltage limits (including ripple)		V	10...30			
Insulation class			□	□	□	□
Switching capacity		mA	≤ 200 with overload and short-circuit protection			
Voltage drop, closed state		V	≤ 2			
Current consumption, no-load		mA	≤ 10			
Maximum switching frequency	Flush	Hz	1000	600	300	100
	Non-flush	Hz	700	400	200	90
Delays	First set-up	ms	40			
	Response	µs	0.05	0.06		
	Recovery	µs	23	15		

## Setting-up

### Minimum mounting distances in mm, flush version

Side by side		Face to face		Facing a metal object		Mounted in a metal support	
∅ 8	e ≥ 14	e ≥ 15		e ≥ 10		d ≥ 12	
∅ 12	e ≥ 38	e ≥ 30		e ≥ 20		d ≥ 24	
∅ 18	e ≥ 42	e ≥ 40		e ≥ 30		d ≥ 50	
∅ 30	e ≥ 80	e ≥ 70		e ≥ 60		d ≥ 90	

### Minimum mounting distances in mm, non-flush version

Side by side		Face to face		Facing a metal object		Mounted in a metal support	
∅ 8	e ≥ 52	e ≥ 25		e ≥ 20		d ≥ 20	h ≥ 15
∅ 12	e ≥ 108	e ≥ 40		e ≥ 30		d ≥ 30	h ≥ 22
∅ 18	e ≥ 182	e ≥ 70		e ≥ 60		d ≥ 60	h ≥ 34
∅ 30	e ≥ 270	e ≥ 130		e ≥ 120		d ≥ 120	h ≥ 34

## Dimensions

	Flush sensor				Non-flush sensor			
	M8	M12	M18	M30	M8	M12	M18	M30
a (mm)	66	60	63.5	63.5	66	60	63.5	63.5
b (mm)	46	41	42	42	42	36	35	32
c (mm)	0	0	0	0	4	5	7	10

Lengths (mm):  
a = overall  
b = threaded  
c = for non-flush mountable sensors

## Reduction coefficient

Non-flush mounted		Flush sensor				Non-flush sensor			
		M8	M12	M18	M30	M8	M12	M18	M30
Steel		1	1	1	1	1	1	1	1
Aluminum		1	1	1	1	1	1	1	1
Brass		1.35	1.3	1.2	1.3	1.4	1.4	1.35	1.2
Copper		0.9	0.85	0.8	0.9	0.85	0.8	0.9	0.9
Stainless steel	Thickness 1 mm	0.3	0.5	0.5	0.35	0.3	(1)	0.3	(1)
	Thickness 2 mm	0.6	0.9	0.9	0.7	0.9	0.66	0.6	0.25

(1) No detection.

Flush mounted		M8	M12	M18	M30
Steel		1	0.7	0.75	0.9
Aluminum		0.9	1.15	0.9	0.7
Brass		0.9	1.05	0.75	0.6
Stainless steel		1	0.8	0.8	1.3

## Inductive proximity sensors

XS range application

Flat sensor, flush mountable, increased range,

Switching capacity 300 mA

80 x 80 x 40 format, DIN rail mounting, solid-state output

**Sensor type** Flush mountable in metal



<b>Dimensions</b>	<b>mm</b>	80 x 80 x 40
<b>Nominal sensing distance (Sn)</b>	<b>mm</b>	50 (not flush mounted: 42)
<b>Reference</b>		
<b>2-wire</b> --- (non polarised) NO		<b>XS7D1A3CAM12DIN</b>
<b>Weight</b>	<b>kg</b>	0.374
<b>Characteristics</b>		
<b>Product certifications</b>		CE, UKCA
<b>Degree of protection</b> Conforming to IEC 60529		IP 67
<b>Temperature</b>	Operating	°C - 25...+ 70
	Storage	°C - 40...+ 85
<b>Vibration resistance</b> Conforming to IEC 60068-2-6		25 gn, amplitude ± 2 mm (f = 10 to 55 Hz)
<b>Shock resistance</b> Conforming to IEC 60068-2-27		50 gn, duration 11 ms
<b>Connection</b>		M12 connector
<b>Operating zone</b>	<b>mm</b>	<b>0...40 (not flush mounted: 0...35)</b>
<b>Repeat accuracy</b>	<b>%</b>	3 of Sr
<b>Differential travel</b>	<b>%</b>	1...15 of Sr
<b>Output state indication</b>		Yellow LED
<b>Rated supply voltage</b>	<b>V</b>	--- <b>12...48 with protection against reverse polarity</b>
<b>Voltage limits (including ripple)</b>	<b>V</b>	--- 10...58
<b>Insulation class</b>		□
<b>Residual current, open state</b>	<b>mA</b>	≤ 0.5
<b>Switching capacity</b>	<b>mA</b>	<b>1.5...300 with overload and short-circuit protection</b>
<b>Voltage drop, closed state</b>	<b>V</b>	≤ 4.5
<b>Maximum switching frequency</b>	<b>Hz</b>	100
<b>Delays</b>	First-up	<b>ms</b> ≤ 10
	Response	<b>ms</b> ≤ 2
	Recovery	<b>ms</b> ≤ 5

# Inductive proximity sensors

XS range application

Flat sensor, flush mountable, increased range,

Switching capacity 300 mA

80 x 80 x 40 format, DIN rail mounting, solid-state output

## Dimensions

XS7D1A3CAM12DIN

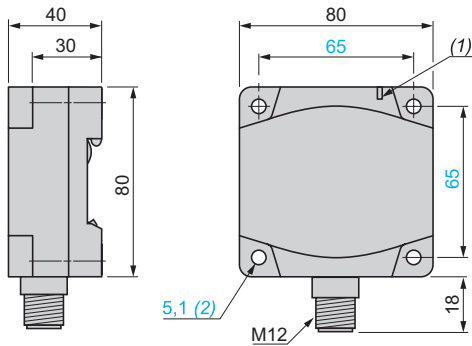

(1) Output LED

(2) For CHC type screws

## Setting-up

Minimum mounting distances (mm)

Face to face

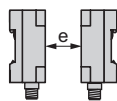

Side by side

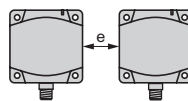

Back to back

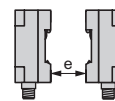

Facing a metal object

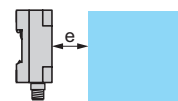

Flush mounted

450

140

90

150

Not flush mounted

450

180

180

150

## Flush/non-flush conditions

In A37 steel

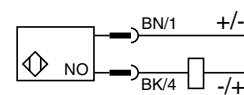
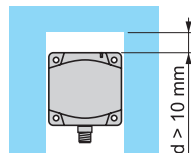
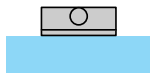

**Sn**  
42 mm

**Su**  
35 mm

**Sn**  
50 mm

**Su**  
40 mm

## Wiring schemes

2-wire NO/M12 XS7D1A3CAM12DIN

# Inductive proximity sensors

XS range application

Cylindrical, stainless steel 303 front face, for welding environments

Three-wire DC, solid-state output

PF120809



XS912RWPAM12

## Ø 12 mm, threaded M12 x 1

Sensing distance (Sn) mm	Function	Output	Connection	Reference	Weight (kg)
<b>Three-wire 12-24V <math>\overline{\text{DC}}</math>, flush mountable</b>					
6	NO	PNP	M12	<b>XS912RWPAM12</b>	0.024

PF120809



XS918RWPAM12

## Ø 18 mm, threaded M18 x 1

Sensing distance (Sn) mm	Function	Output	Connection	Reference	Weight (kg)
<b>Three-wire 12-24V <math>\overline{\text{DC}}</math>, flush mountable</b>					
10	NO	PNP	M12	<b>XS918RWPAM12</b>	0.051

XZCPA1241L\_MAIN



XZCPA1241L●

XZCP1141L\_MAIN



XZCP1141L●

## Connecting cables (PUR) (1)

Description	Type	Length m	Reference	Weight (kg)
<b>Pre-wired M12 connectors</b> Female, 4-pin Metal clamping ring	Straight	2	<b>XZCP1141L2</b>	0.090
		5	<b>XZCP1141L5</b>	0.190
		10	<b>XZCP1141L10</b>	0.370
	Elbowed	2	<b>XZCP1241L2</b>	0.090
		5	<b>XZCP1241L5</b>	0.190
		10	<b>XZCP1241L10</b>	0.370

## Wiring schemes

### M12 connector



### PNP

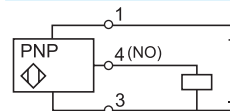

(1) For further information, please consult our site [www.telemecaniquesensors.com](http://www.telemecaniquesensors.com).

# Inductive proximity sensors

XS range application

Cylindrical, stainless steel 303 front face, for welding environments

Three-wire DC, solid-state output

Characteristics		XS912RWPAM12	XS918RWPAM12
Sensor type	Flush	XS912RWPAM12	XS918RWPAM12
Product certifications		cULus, CC, UKCA	
Connection	Connector	M12	
Operating zone		mm	0...4.8
Differential travel		%	1...15 (real sensing distance Sr)
Degree of protection	Conforming to IEC 60529	IP 68 (5 meters underwater for 1 month)	
	Conforming to DIN 40050	IP 69K	
Storage temperature		°C	-25...+70 (-13...158°F)
Operating temperature		°C	-25...+70 (-13...158°F)
Materials	Case	Stainless steel, 303 grade	
Front face thickness		mm	0.4
Mechanical shock resistance	Conforming to IEC 62262	IK10	
Vibration resistance	Conforming to IEC 60068-2-6	25 gn, amplitude ± 1 mm (f = 10 to 55 Hz)	
Shock resistance	Conforming to IEC 60068-2-27	30 gn, duration 11 ms	
Output state indication		Yellow LED, 4 viewing points at 90° (blinking from 0.8 Sr and Sr)	
Rated supply voltage		V	--- 12...24 with protection against reverse polarity
Voltage limits (including ripple)		V	--- 10...30
Insulation class			□
Switching capacity		mA	≤ 200 with overload and short-circuit protection
Voltage drop, closed state		V	≤ 2
Current consumption, no-load		mA	≤ 10
Maximum switching frequency		Hz	15
Delays	First set-up	ms	80
	Response	µs	100
	Recovery	µs	15

## Setting-up

### Minimum mounting distances in mm, flush version

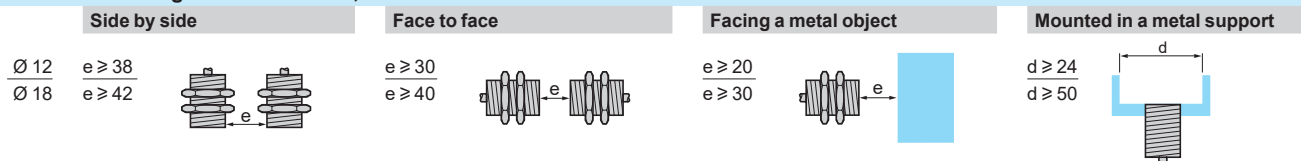

## Dimensions

Lengths (mm):  
a = overall  
b = threaded  
c = for non-flush mountable sensors

	Flush sensor	
	M12	M18
a (mm)	60	63.5
b (mm)	41	42
c (mm)	0	0

## Reduction coefficient

### Non-flush mounted

	Flush sensor	
	M12	M18
Steel	1	1
Aluminum	1	1
Brass	1.3	1.2
Copper	0.85	0.8
Stainless steel	0.5	0.5
Thickness 1 mm	0.5	0.5
Thickness 2 mm	0.9	0.9

### Flush mounted

	M12	M18
Steel	0.7	0.75
Aluminum	1.15	0.9
Brass	1.05	0.75
Stainless steel	0.8	0.8

# Inductive proximity sensors

## XS range application

Factor 1 sensors for ferrous or non-ferrous material detection and welding applications. Plastic case, 40 x 40 mm front face. 5-position turret head

<b>Sensor type</b>	Flush mountable in metal	
<b>Dimensions</b>	mm 40 x 40 x 70	40 x 40 x 117



<b>Nominal sensing distance (Sn)</b>	mm	20
--------------------------------------	----	----

### References

<b>4-wire ---</b>	PNP NO+NC	XS9C2A1PCM12	XS9C4A1PCP20 (1)
	NPN NO+NC		
<p>XS9C4A1PCP20 sensors are available with an ISO M20 cable entry and can be supplied with a Pg 13.5 (e.g. XS9C4A1PCG13) or a 1/2" NPT (e.g. XS9C4A1PCN12) cable entry: please consult our Customer Care Centre for more information.</p>			
<b>Weight</b>	kg	0.110	0.220

### Characteristics

<b>Product certifications</b>		cULus, CE, UKCA
<b>Conformity to standards</b>		IEC 60947-5-2
<b>Connection</b>		M12 connector (4-pin) <span style="float:right">Screw terminals, clamping capacity 4 x 1.5 mm<sup>2</sup> / 4 x 16 AWG</span>
<b>Operating zone</b>	mm	0...16
<b>Differential travel</b>	%	3...15 of Sr
<b>Repeat accuracy</b>	%	< 3
<b>Immunity to magnetic fields</b>		< 250 mTesla
<b>Degree of protection</b>	Conforming to IEC 60529 and DIN 40050	IP 65, IP 67 and IP 69K
<b>Temperature</b>	Storage	°C -40...+85
	Operation (2)	°C -25...+70
<b>Material</b>		Case: PBT
<b>Vibration resistance</b>	Conforming to IEC 60068-2-6	25 gn, amplitude ± 2 mm (f = 10...55 Hz)
<b>Shock resistance</b>	Conforming to IEC 60068-2-27	50 gn for 11 ms
<b>Indicators</b>		Output state: yellow LED. Supply on: green LED
<b>Rated supply voltage</b>	4-wire ---	V --- 12...24 with protection against reverse polarity
<b>Voltage limits (including ripple)</b>	4-wire ---	V --- 10...36
<b>Insulation class</b>		□ □
<b>Current consumption, no-load</b>	4-wire ---	mA < 30
<b>Switching capacity</b>	4-wire ---	mA < 200 with protection against overload and short-circuit
<b>Voltage drop, closed state</b>	4-wire ---	V < 2
<b>Maximum switching frequency</b>	4-wire ---	Hz 250
<b>Delays</b>	First-up	ms < 15
	Response	ms < 2.5
	Recovery	ms < 2.5

### Setting-up

**Sensing distance correction factor**

SS: stainless steel, Fe: steel, Al: aluminium, Cu: copper.

**Operating distance (according to the sensor's level of flush mounting)**

--- : Flush mounted in Fe360 — : Flush mounted in aluminium

(1) These sensors are supplied without a cable gland. A suitable Pg 13.5 cable gland is available (reference XSZPE13).  
 (2) Sensors are available for very low temperatures (suffix TF: -40°C, +70°C) or very high temperatures (suffix TT: -25°C, +85°C); please consult our Customer Care Centre.

# Inductive proximity sensors

## XS range application

Factor 1 sensors for ferrous or non-ferrous material detection and welding applications. Plastic case, 40 x 40 mm front face. 5 position turret head

### Setting-up (continued)

#### Minimum mounting distances (mm)

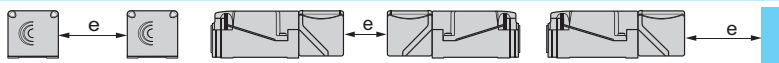

Side by side

Face to face

Facing a metal object

Sensors flush mountable in metal

$e \geq 80$

$e \geq 200$

$e \geq 60$

### Wiring schemes

#### M12 connector



1: + V  
2: NC Output  
3: 0 V  
4: NO Output

#### 4-wire $\overline{N}$ , NO + NC outputs

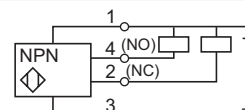
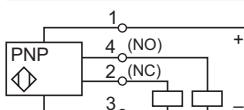

### Accessories



XSZPSC2

Description	Use for	Reference	Weight (kg)
<b>Stainless steel rigid protective cover</b> (only suitable for use when detecting from the top)	Welding	XSZPSC2	0.010

### Dimensions

#### XS9C2A1PCM12 and XS9C2A1NCM12

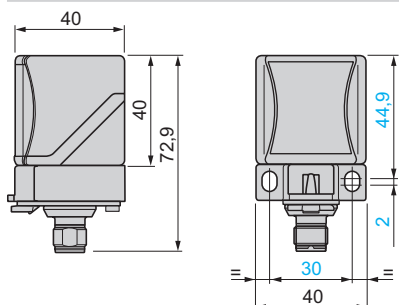

### Head positions

#### XS9C2A1PCM12 and XS9C2A1NCM12

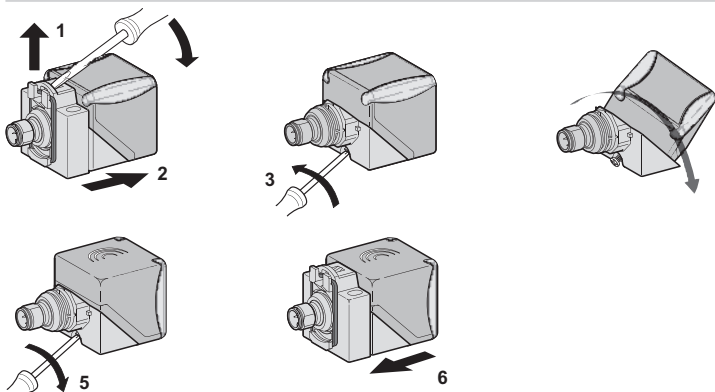

#### XS9C4A1PCP20

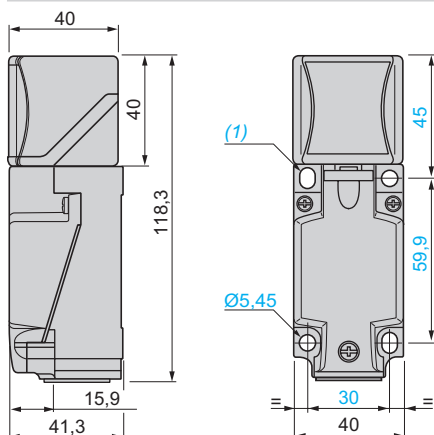

#### XS9C4A1PCP20

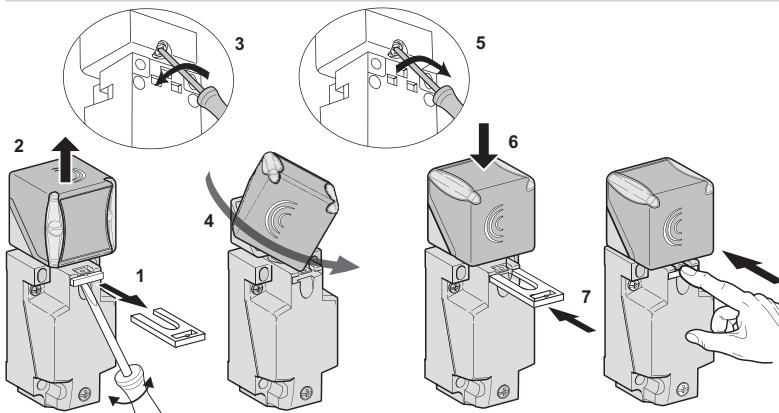

(1) 2 elongated holes  $\varnothing 5.3 \times 7$  mm.

Tightening torque of cover fixing screws and clamp screws:  $< 1.2 \text{ N.m} / < 10.62 \text{ lb-in}$ .

## Inductive proximity sensors

XS range application

Selective detection of ferrous and non-ferrous materials

Cylindrical type, solid-state output

**Sensor type** Flush mountable  
Stainless steel case



Nominal sensing distance (Sn)	mm	5
-------------------------------	----	---

### References

3-wire, ferrous version Insensitive to non ferrous materials	PNP NO		XS1M18PAS40D
3-wire, non ferrous version Insensitive to ferrous materials	PNP NO		XS1M18PAS20D
Weight	kg	0.060	

### Characteristics

Product certifications		cULus, CE, UKCA	
Connection		M12 connector	
Degree of protection conforming to IEC 60529		IP 67	
Operating zone	mm	0...4	
Operating temperature	°C	- 25...+ 70	
Output state indication		Yellow LED, 4 viewing ports at 90°	
Rated supply voltage	V	DC 12...24 with protection against reverse polarity	
Voltage limits (including ripple)	V	DC 10...38	
Insulation class		□	
Switching capacity		0...200 mA with overload and short-circuit protection	
Voltage drop, closed state	V	≤ 2.6	
Residual current, open state		-	
Current consumption, no-load	mA	≤ 15	
Maximum switching frequency	Hz	1000	
Delays	First-up	ms	≤ 10
	Response	ms	≤ 0.3
	Recovery	ms	≤ 0.7

# Inductive proximity sensors

XS range application

Selective detection of ferrous and non-ferrous materials

Cylindrical type, solid-state output

## Wiring schemes

M12 connector

3-wire PNP

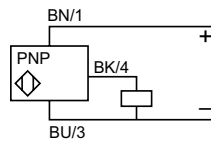

## Dimensions

XS1M

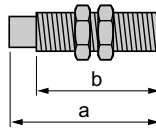

a (mm)	b (mm)
70	51.5

## Setting-up

Minimum mounting distances (mm)

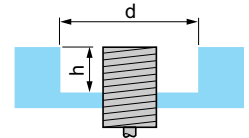
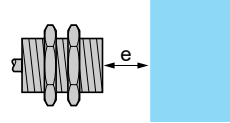
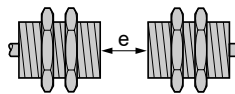
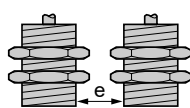

XS1M18

Side by side

$e \geq 10$

Face to face

$e \geq 60$

Facing a metal object

$e \geq 15$

Mounted in a metal support

$d \geq 18, h \geq 0$  (ferrous metal)

$d \geq 18, h \geq 5$  (non ferrous metal)

# Inductive proximity sensors

XS range, Fail Safe

Cylindrical, metal, flush mountable

Standard sensing distance

Four-wire DC, solid-state NO + NC output, SIL2, PLd, cat 2



XS512BSPD●●



XS518BSPD●●



XS530BSPD●●



XSZB1●●

### Sensors, 4-wire, brass case, flush mountable

Sensing distance (Sn) mm	Function	Output	Connection	Reference	Weight (kg)
<b>Ø 12, threaded M12 x 1</b>					
2	NO + NC	PNP	Pre-cabled (L = 2 m)	<b>XS512BSPDL2</b>	0.070
			M12 connector	<b>XS512BSPDM12</b>	0.020
<b>Ø 18, threaded M18 x 1</b>					
5	NO + NC	PNP	Pre-cabled (L = 2 m)	<b>XS518BSPDL2</b>	0.100
			M12 connector	<b>XS518BSPDM12</b>	0.040
<b>Ø 30, threaded M30 x 1.5</b>					
10	NO + NC	PNP	Pre-cabled (L = 2 m)	<b>XS530BSPDL2</b>	0.160
			M12 connector	<b>XS530BSPDM12</b>	0.100

### Accessories

Description	For use with sensors (mm)	Reference	Weight (kg)
Fixing clamps	Ø 12	<b>XSZB112</b>	0.006
	Ø 18	<b>XSZB118</b>	0.010
	Ø 30	<b>XSZB130</b>	0.020

# Inductive proximity sensors

XS range, Fail Safe

Cylindrical, metal, flush mountable

Standard sensing distance

Four-wire DC, solid-state NO + NC output, SIL2, PLd, cat 2

Characteristics		XS5●●BSPDM12	XS5●●BSPDL2
Sensor type		XS5●●BSPDM12	XS5●●BSPDL2
Product certifications		cULus, Cc, UKCA, E2	cULus, Cc, UKCA, E2
Conformity to safety standards	Ø 12, Ø 18 and Ø 30	IEC 60947-5-2 IEC 60947-5-3 EN/IEC 61508: SIL 2 EN/ISO 13849-1: PL = d IEC 62061: SILcl2	
Reliability data	Ø 12, Ø 18 and Ø 30	MTTFd = 2422 years, PFHd = 47.1 10 <sup>-9</sup> 1/h, SFF > 98.9 %, DC > 96 % (with a safety controller)	
Connection		M12 connector	Pre-cabled, length: 2m
Operating zone (Sao/Sar)	Ø 12 flush mountable	mm	0.4...1.6/2.8
	Ø 18 flush mountable	mm	1.5...4/7
	Ø 30 flush mountable	mm	4.9...8.1/13.9
Differential travel		%	
Degree of protection	Conforming to IEC 60529	IP 65 and IP 67	
	Conforming to DIN 40050	IP 69K	
Storage temperature		°C	
		- 40...+ 85	
Operating temperature		°C	
		- 40...+ 70	
Materials	Case/Sensing face	Nickel plated brass/PPS	
	Cable		PVC 4 x 0.22 mm <sup>2</sup> (Ø 12, Ø 18 and Ø 30)
Vibration resistance	Conforming to IEC 60068-2-6	25 gn, amplitude ± 2 mm (f = 10 to 55 Hz)	
Shock resistance	Conforming to IEC 60068-2-27	50 gn, duration 11 ms	
Output state indication		Yellow LED, 4 viewing ports at 90°	
Rated supply voltage		V	
		--- 12...24 with protection against reverse polarity	
Voltage limits (including ripple)		V	
		--- 10...36	
Insulation class		□	
Switching capacity		mA	
		≤ 200 with overload and short-circuit protection	
Voltage drop, closed state		V	
		≤ 2	
Current consumption, no-load		mA	
		≤ 10	
Maximum switching frequency	Ø 12	Hz	85
	Ø 18	Hz	85
	Ø 30	Hz	85
Delays	First-up	ms	≤ 10
	Response	ms	≤ 5.7
	Recovery	ms	≤ 5.7

## Wiring schemes

M12 connector	Pre-cabled	PNP 4-wire
	BU: Blue BN: Brown BK: Black WH: White	

## Setting-up

Sensor	Minimum mounting distances (mm)			
	Side by side	Face to face	Facing a metal object	Mounted in a metal support
Ø 12 flush mountable XS512	e ≥ 4	e ≥ 24	e ≥ 6	d ≥ 12 h ≥ 0
Ø 18 flush mountable XS518	e ≥ 10	e ≥ 60	e ≥ 15	d ≥ 18 h ≥ 0
Ø 30 flush mountable XS530	e ≥ 20	e ≥ 120	e ≥ 30	d ≥ 30 h ≥ 0

## Dimensions

Flush mountable in metal		Pre-cabled (mm)		M12 connector (mm)	
Sensor		a	b	a	b
Ø 12 brass	XS512	37	25	50	31
Ø 18 brass	XS518	41	29	51	28
Ø 30 brass	XS530	45	33	54	33

# Inductive proximity sensors

XS range, Fail Safe

Cylindrical, metal, flush mountable

Increased range

Four-wire DC, solid-state NO + NC output, SIL2, PLd, cat 2



XS112B3PD●●



XS118B3PD●●



XSZB1●●

### Sensors, 4-wire 12...24 V, short case model

Sensing distance (Sn) mm	Function	Output	Connection	Reference	Weight (kg)
<b>Ø 12, threaded M12 x 1</b>					
4	NO + NC	PNP	Pre-cabled (L = 2 m)	<b>XS112B3PDL2</b>	0.070
			M12 connector	<b>XS112B3PDM12</b>	0.020
<b>Ø 18, threaded M18 x 1</b>					
8	NO + NC	PNP	Pre-cabled (L = 2 m)	<b>XS118B3PDL2</b>	0.100
			M12 connector	<b>XS118B3PDM12</b>	0.040
<b>Ø 30, threaded M30 x 1.5</b>					
15	NO + NC	PNP	Pre-cabled (L = 2 m)	<b>XS130B3PDL2</b>	0.160
			M12 connector	<b>XS130B3PDM12</b>	0.100

### Accessories (1)

Description	For use with sensors (mm)	Reference	Weight (kg)
Fixing clamps	Ø 12	<b>XSZB112</b>	0.006
	Ø 18	<b>XSZB118</b>	0.010
	Ø 30	<b>XSZB130</b>	0.020

(1) For further information, see page 120.

# Inductive proximity sensors

XS range, Fail Safe

Cylindrical, metal, flush mountable

Increased range

Four-wire DC, solid-state NO + NC output, SIL2, PLd, cat 2

Characteristics		XS1●●B3PDM12	XS1●●B3PDL2
Sensor type			
Product certifications	Ø 12, 18 and 30	cULus, CE, UKCA, E2	
Conformity to safety standards	Ø 12, Ø 18 and Ø 30	IEC 60947-5-2 IEC 60947-5-3 EN/IEC 61508: SIL 2 EN/ISO 13849-1: PL =d IEC 62061: SILcl2	
Reliability data	Ø 12, Ø 18 and Ø 30	MTTFd = 2422 years, PFHd = 47.1 10 <sup>-9</sup> 1/h, SFF > 98.9 %, DC > 96 % (with a safety controller)	
Connection		M12 connector	Pre-cabled, length 2 m
Operating zone (Sao/Sar)	Ø 12	mm	1.2...3.2/5.6
	Ø 18	mm	3...6.5/11.1
	Ø 30	mm	5.8...12.2/20.9
Differential travel		%	1...15 of effective sensing distance (Sr)
Degree of protection	Conforming to IEC 60529	IP 65 and IP 67	IP 65 and IP 68
	Conforming to DIN 40050	IP 69K	–
Storage temperature		°C	-40...+85
Operating temperature		°C	-40...+70
Materials	Case	Nickel plated brass	
	Sensing face	PPS	
	Cable	–	PVC 4 x 0.22 mm <sup>2</sup>
Vibration resistance	Conforming to IEC 60068-2-6	25 gn, amplitude ± 2 mm (f = 10 to 55 Hz)	
Shock resistance	Conforming to IEC 60068-2-27	50 gn, duration 11 ms	
Output state indication		Yellow LED, 4 viewing ports at 90°	Yellow LED, annular
Rated supply voltage		V	~ 12...24 with protection against reverse polarity
Voltage limits (including ripple)		V	~ 9...36
Insulation class			III
Switching capacity		mA	≤ 200 with overload and short-circuit protection
Voltage drop, closed state		V	≤ 2
Current consumption, no-load		mA	≤ 10
Maximum switching frequency	Ø 12	Hz	85
	Ø 18	Hz	85
	Ø 30	Hz	85
Delays	First-up	ms	≤ 10
	Response	ms	≤ 5.7
	Recovery	ms	≤ 5.7

## Wiring schemes

### M12 connector



### Pre-cabled

BU: Blue  
BN: Brown  
BK: Black  
WH: White

### PNP 4-wire

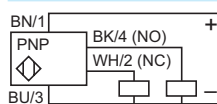

## Setting-up

### Minimum mounting distances (mm)

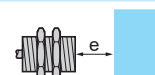
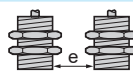

Sensors	Side by side	Face to face	Facing a metal object
Ø 12	e ≥ 8	e ≥ 50	e ≥ 12
Ø 18	e ≥ 16	e ≥ 100	e ≥ 25
Ø 30	e ≥ 30	e ≥ 180	e ≥ 45

## Dimensions

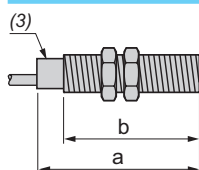

Sensors	Pre-cabled (mm)		M12 connector (mm)	
	a	b	a	b
Ø 12	37	25	50	31
Ø 18	41	29	51	28
Ø 30	45	33	54	33

(3) LED.

# Inductive proximity sensors

XS range, Fail Safe

Cubic case, 40 x 40 x 70 mm, M12 connector

5-position turret head

Four-wire DC, solid-state NO + NC output, SIL2, PLd, cat 2

Sensor type		Flush mountable in metal	Non-flush mountable in metal
			
Nominal sensing distance (Sn)	mm	20	40
<b>References</b>			
4-wire ---	PNP NO+NC	<b>XS8C2A1PDM12</b>	<b>XS8C2A4PDM12</b>
Weight	kg	0.149	0.149
<b>Characteristics</b>			
Operating zone (Sao/Sar)	mm	8.3...16.2/27.8	18.4...32.4/55.7
Product certifications		cULus, CE, UKCA, TÜV (4-wire), E2 (3-wire and 4-wire)	
Conformity to standards		IEC 60947-5-2 IEC 60947-5-3	
Conformity to safety standards (1)		EN 62061 (2005): SILcl2 EN 61508 (2010): SIL 2, EN ISO 13849 (2008): PL d	
Reliability data (1)		MTTFd = 2422 years, PFHd = 7.4 10 <sup>-8</sup> 1/h, SFF > 98.9 %, DC > 96 % (with a safety controller)	
Connection		M12 connector	
Differential travel	%	3...15 of Sr	
Degree of protection	Conforming to IEC 60529 and DIN 40050	IP 65, IP 67 and IP 69K	
Temperature	Storage	°C - 40...+ 85	
	Operation (3)	°C - 40...+ 70	
Material	Case	PBT	
Vibration resistance	Conforming to IEC 60068-2-6	25 gn, amplitude ± 2 mm (f = 10...55 Hz)	
Shock resistance	Conforming to IEC 60068-2-27	50 gn for 11 ms	
Indicators	Output state	Yellow LED	
	Power on	Green LED	
Rated supply voltage	4-wire ---	V	12...48 with protection against reverse polarity
Voltage limits (including ripple)	4-wire ---	V	10...58
Insulation class			□
Current consumption, no-load	4-wire ---	mA	< 15
Switching capacity	4-wire ---	mA	< 200 with overload and short-circuit protection
Voltage drop, closed state	4-wire ---	V	< 2
Maximum switching frequency	Flush mountable		--- 40
	Non-flush mountable	Hz	--- 30
Delays	First-up	ms	Flush mountable: ≤ 12. Non-flush mountable: ≤ 14
	Response	ms	Flush mountable: ≤ 10. Non-flush mountable: ≤ 12.5
	Recovery	ms	Flush mountable: ≤ 10. Non-flush mountable: ≤ 12.5

(1) SIL 2 protection can only be obtained by connecting both outputs to a safety PLC. Please consult our website: [www.telemecaniquesensors.com](http://www.telemecaniquesensors.com).

# Inductive proximity sensors

XS range, Fail Safe

Cubic case, 40 x 40 x 70 mm, M12 connector

5-position turret head

Four-wire DC, solid-state NO + NC output, SIL2, PLd, cat 2

## Setting-up precautions

### Minimum mounting distances (mm)

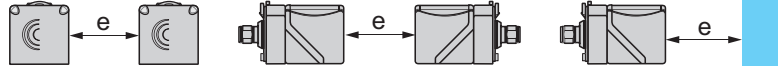

		Side by side	Face to face	Facing a metal object
Sensors flush mountable in metal	XS8C2A1●●	$e \geq 80$	$e \geq 160$	$e \geq 60$
Sensors non-flush mountable in metal	XS8C2A4●●	$e \geq 160$	$e \geq 320$	$e \geq 120$

## Wiring schemes

### 4-wire $\square$ , NO + NC outputs

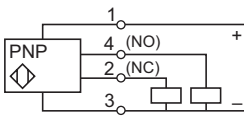

### M12 connector

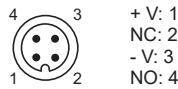

## Accessory references

Description	Type	Length m	Reference	Weight (kg)
Pre-wired M12 connectors Female, 4-pin, zinc die-cast, nickel plated clamping ring	Straight	2	XZCP1141L2	0.090
		5	XZCP1141L5	0.190
		10	XZCP1141L10	0.370
	Elbowed	2	XZCP1241L2	0.090
		5	XZCP1241L5	0.190
		10	XZCP1241L10	0.370

## Dimensions

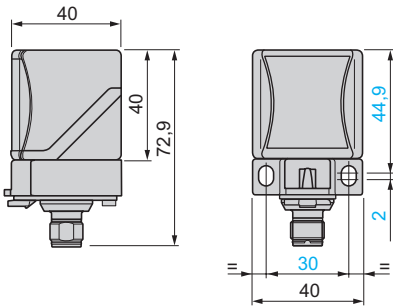

## Head positions

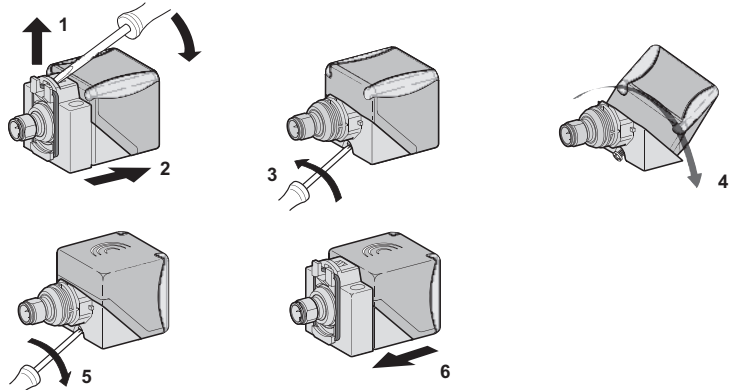

## Example SIL 2 wiring scheme (with XPSMC safety PLC)

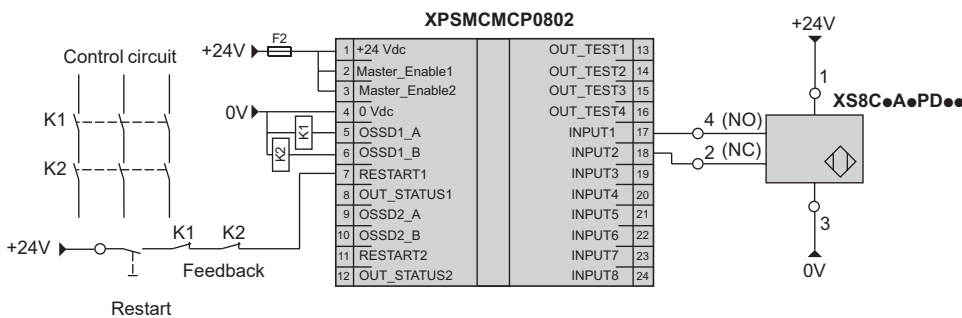

SFF (Safe Failure Fraction): 98,9 %  
DC (Diagnosis Coverage): 96 %

# Inductive proximity sensors

XS range, Fail Safe

Plastic case, 40 x 40 x 117 mm, plug-in

Sensor type		Flush mountable in metal	Non-flush mountable in metal
			
Nominal sensing distance (Sn)	mm	20	40
<b>References</b>			
4-wire ☐	PNP NO+NC	<b>XS8C4A1PDP20</b>	<b>XS8C4A4PDP20</b>
Weight	kg	0.244	0.244
<p><b>Note:</b> These sensors have an M20 cable entry. They can also be supplied with a PG 13.5 cable entry (e.g. <b>XS8C4A4PDG13</b>) or a 1/2" NPT cable entry (e.g. <b>XS8C4A1PDN12</b>). Please consult our Customer Care Centre.</p>			
<b>Characteristics</b>			
Operating zone (Sao/Sar)	mm	8.3...16.2/27.8	18.4...32.4/55.7
Product certifications		cULus, CE, UKCA, TÜV, E2	
Conformity to standards		IEC 60947-5-2 IEC 60947-5-3	
Conformity to safety standards (1)		EN 62061 (2005): SILcl2, EN 61508 (2010): SIL 2, EN ISO 13849 (2008): PL d	
Reliability data (1)		MTTFd = 2422 years, PFHd = 7.4 10 <sup>-8</sup> 1/h, SFF > 98.9 %, DC > 96 % (with a safety controller)	
Connection		Screw terminals, clamping capacity: 2 or 4 x 1.5 mm <sup>2</sup> / 2 or 4 x 16 AWG (3)	
Differential travel	%	3...15 of Sr	
Degree of protection	Conforming to IEC 60529 and DIN 40050	IP 65, IP 67 and IP 69K	
Temperature	Storage	°C - 40...+ 85	
	Operation	°C - 40...+ 70	
Material		Case: PBT	
Vibration resistance	Conforming to IEC 60068-2-6	25 gn, amplitude ± 2 mm (f = 10...55 Hz)	
Shock resistance	Conforming to IEC 60068-2-27	50 gn for 11 ms	
Indicators	Output state	Yellow LED	
	Power on	Green LED	
Rated supply voltage	4-wire ☐	V 12...48 with protection against reverse polarity	
Voltage limits (including ripple)	4-wire ☐	V 10...58	
Insulation class		□	□
Current consumption, no-load	4-wire ☐	mA < 15	
Switching capacity	4-wire ☐	mA < 200 mA with overload and short-circuit protection	
Voltage drop, closed state	4-wire ☐	V < 2	
Maximum switching frequency		Hz Flush mountable: ☐ 40 Non-flush mountable: ☐ 30	
Delays	First-up	ms Flush mountable: ≤ 12. Non-flush mountable: ≤ 14.	
	Response	ms Flush mountable: ≤ 10. Non-flush mountable: ≤ 12.5.	
	Recovery	ms Flush mountable: ≤ 10. Non-flush mountable: ≤ 12.5.	

(1) SIL 2 protection can only be obtained by connecting both outputs to a safety PLC. Please consult our website [www.telemecanique.com](http://www.telemecanique.com).



# Inductive proximity sensors

## XS range Accessories



XSZBE10



XSZBC10



XSZBD10



XSZB100



XSZP100



XSZC01

### Mounting and fixing accessories

Description	For use with sensor		Unit reference	Weight (kg)
	Type	Diameter (mm)		
Replacement bracket	XS●E Replaces: XS7T2, XS8T2, XSE	–	<b>XSZBE10</b>	0.060
	XS●C Replaces: XS7T4, XS7C40, XS8T4, XS8C40 and XSC	–	<b>XSZBC10</b>	0.110
	XS●D (for XSD) (1)	–	<b>XSZBD10</b>	0.065
Fixing clamps	XS1, XS2, XS4, XS5, XS6	8 (M8 x 1)	<b>XSZB108</b>	0.006
	XS1, XS2, XS4, XS5, XS6	12 (M12 x 1)	<b>XSZB112</b>	0.006
		18 (M18 x 1)	<b>XSZB118</b>	0.010
		30 (M30 x 1.5)	<b>XSZB130</b>	0.020
Set of 2 metal fixing nuts, XS1, XS2, XS5, XS6 nickel plated		12 (M12 x 1)	<b>XSZE112</b>	0.015
		18 (M18 x 1)	<b>XSZE118</b>	0.020
		30 (M30 x 1.5)	<b>XSZE130</b>	0.050

### Protection accessories

Description	For use with sensor		Unit reference	Weight (kg)
	Type	Diameter (mm)		
Cable sleeve adaptor (CNOMO type)	XS●, XT●	12 (M12 x 1)	<b>XSZP112</b>	0.005
		18 (M18 x 1)	<b>XSZP118</b>	0.005
		30 (M30 x 1.5)	<b>XSZP130</b>	0.010
Outer cover (IP 68)	XT7, XS7, XS8 and XS9 – (C format)		<b>XSCZ01</b>	0.100

### Fuses (for unprotected 2-wire $\overline{\text{---}}/\sim$ sensors)

Description	Type	Sold in lots of	Unit reference	Weight (kg)
Cartridge fuses 5 x 20	0.4 A "quick-blow"	10	<b>XUZE04</b>	0.001
	0.63 A "quick-blow"	10	<b>XUZE06</b>	0.001
	0.8 A "quick-blow"	10	<b>XUZE08</b>	0.001

(1) Depth adjustment shim for converting 80 x 80 x 26 mm format to 80 x 80 x 40 mm format. Also enables clipping onto 35 mm omega rail.

### XSZBE10

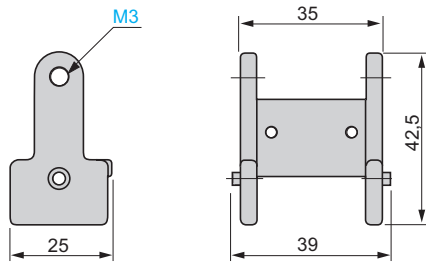

### XSZBC10

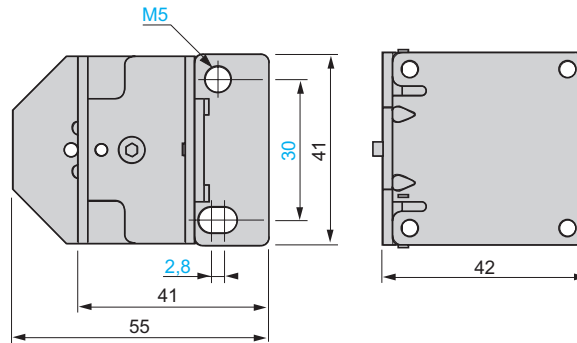

### XSZBD10 (for mounting on XS●D●●●●)

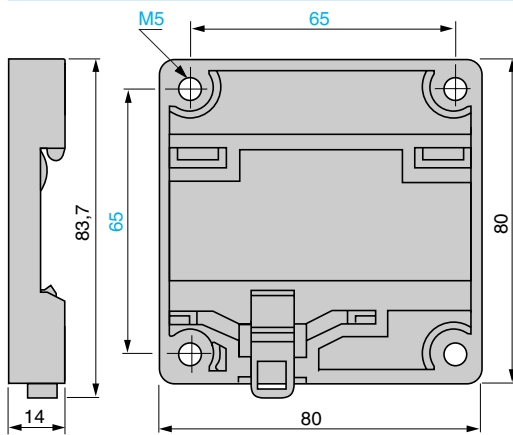

### XSZB108, XSZB112, XSZB118, XSZB130, XSZB165

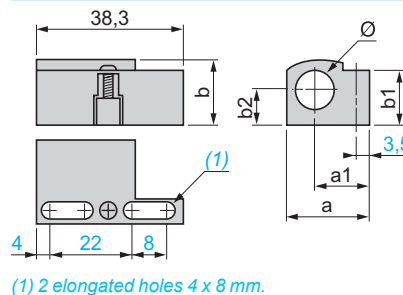

XSZ	a	a1	b	b1	b2	Ø
B112	21.9	14.5	16	15.5	8.5	12
B118	26	15.7	22.3	20.1	11.5	18
B130	39	21.7	35.5	31	18.5	30

### XSZP112, XSZP118, XSZP130

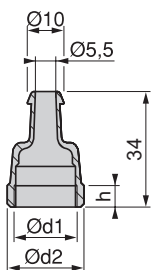

XSZ	h	Ø d1	Ø d2
P112	7	12	16,8
P118	6,2	18	23
P130	6,2	30	34,4

### XSCZ01

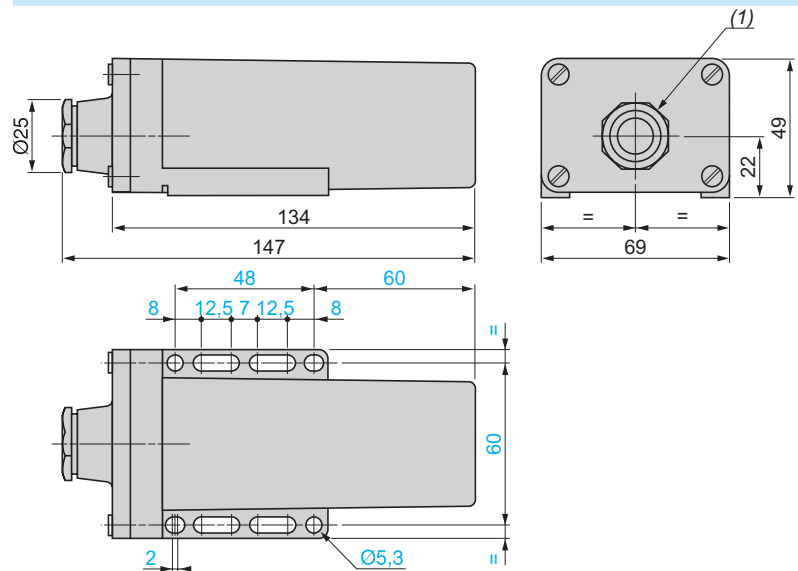

(1) 13P cable gland

#### Cylindrical type sensors

##### Flush mountable in metal

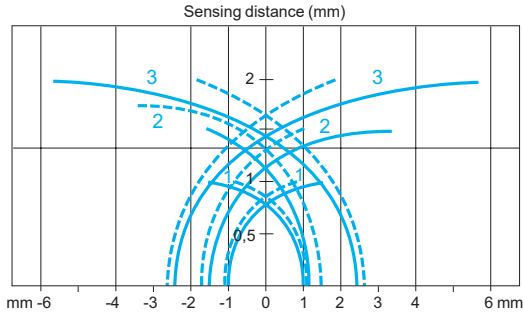

Sensor (mm)	Standard steel target (mm)	Operating zone (mm)
Ø 4	5 x 5 x 1	0...0.8
Ø 5	5 x 5 x 1	0...0.8
Ø 6.5	8 x 8 x 1	0...1.2
Ø 8	8 x 8 x 1	0...1.2
Ø 12	12 x 12 x 1	0...1.6

— pick-up points  
 - - - drop-out points (object approaching from the side)  
 1 Ø 4 (plain) XS1 and Ø 5 (M5 x 0.5) XS1  
 2 Ø 6.5 (plain) XS1 and Ø 8 (M8 x 1) XS5  
 3 Ø 12 (M12 x 1) XS5

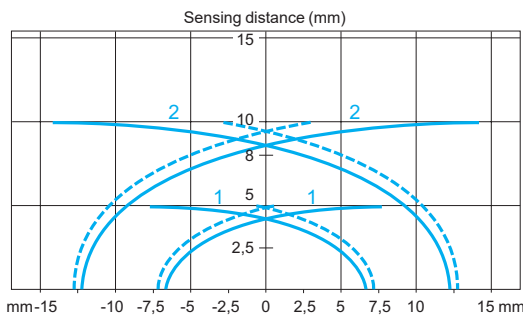

Sensor (mm)	Standard steel target (mm)	Operating zone (mm)
Ø 18	18 x 18 x 1	0...4
Ø 30	30 x 30 x 1	0...8

— pick-up points  
 - - - drop-out points (object approaching from the side)  
 1 Ø 18 (M18 x 1) XS5  
 2 Ø 30 (M30 x 1.5) XS5

##### Non flush mountable in metal

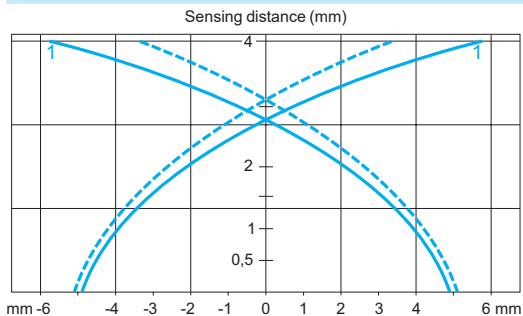

Sensor (mm)	Standard steel target (mm)	Operating zone (mm)
Ø 12	12 x 12 x 1	0...3.2

— pick-up points  
 - - - drop-out points (object approaching from the side)  
 1 Ø 12 (M12 x 1) XS4

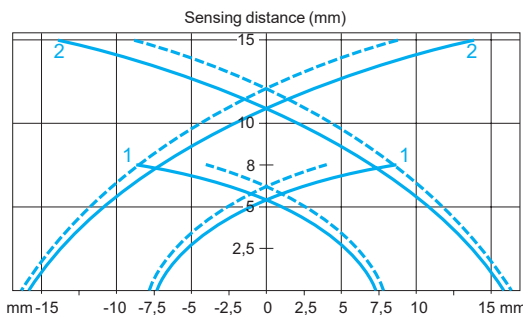

Sensor (mm)	Standard steel target (mm)	Operating zone (mm)
Ø 18	24 x 24 x 1	0...6.4
Ø 30	45 x 45 x 1	0...12

— pick-up points  
 - - - drop-out points (object approaching from the side)  
 1 Ø 18 (M18 x 1) XS4  
 2 Ø 30 (M30 x 1.5) XS4

##### Quasi-flush mountable in metal

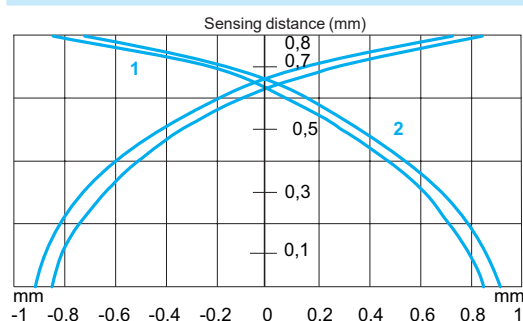

Sensor (mm)	Standard steel target (mm)	Operating zone (mm)
Ø 4	4 x 4 x 1	0...0.65
Ø 5	5 x 5 x 1	0...0.65

1 Ø 4  
 2 Ø 5

#### Cylindrical type sensors, increased range

##### Flush mountable in metal

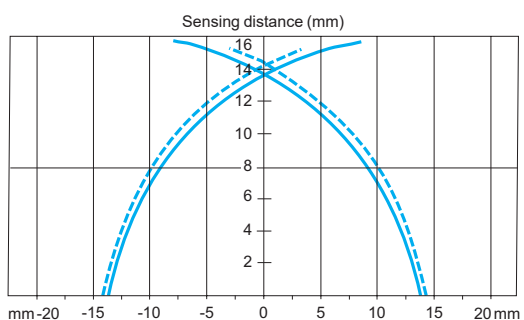
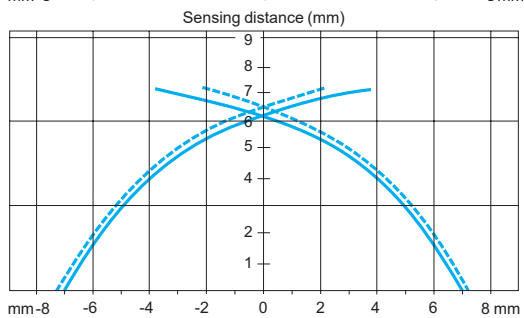
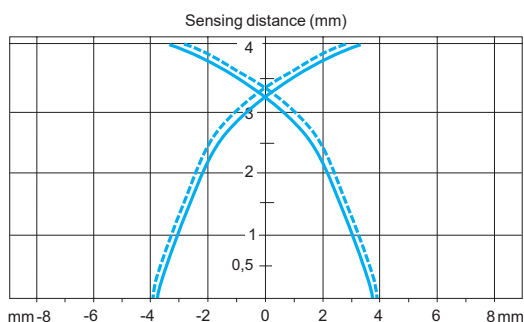
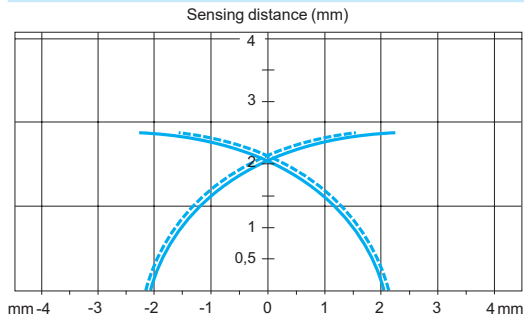

##### Quasi-flush mountable in metal, Ø 4

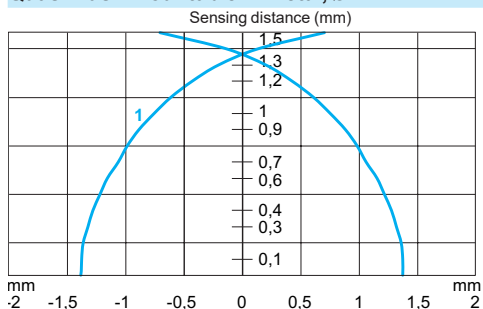

##### Non flush mountable in metal

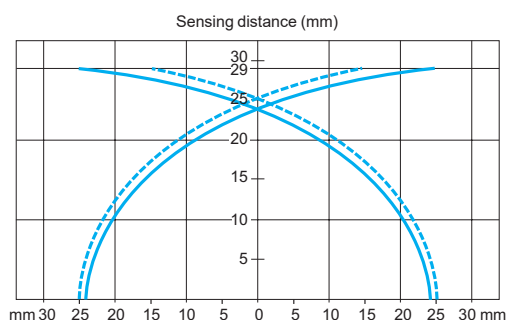
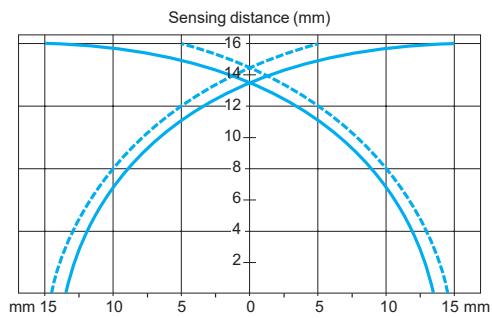
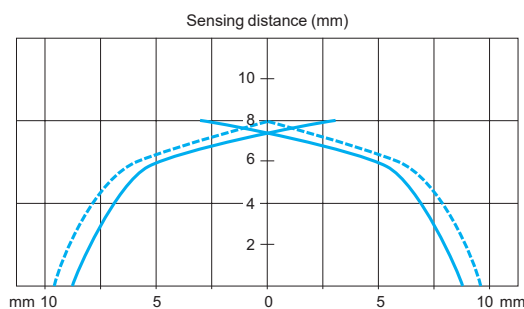
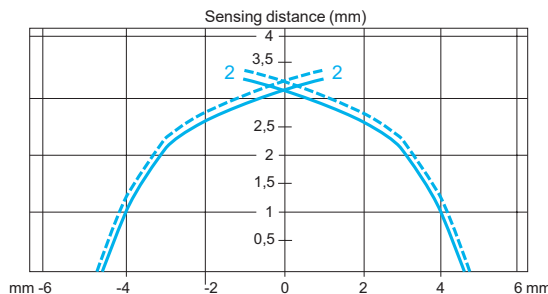

##### Quasi-flush mountable in metal, Ø 5

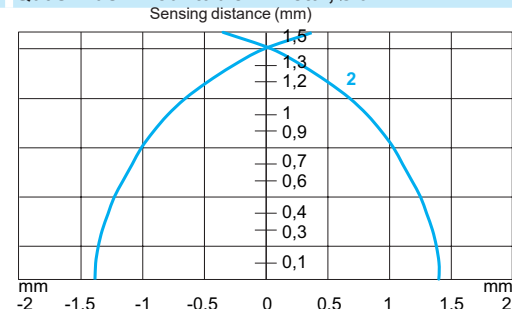

Sensor (mm)

Ø 6,5 and Ø 8

Standard steel target (mm)

8 x 8 x 1

Operating zone (mm)

0...2 (flush mounted)

0...3.2 (not flush mounted)

1 Ø 6.5 (plain) XS106B3●● and Ø 8 (M8 x 1) XS108B3 and XS608B1

2 XS608B4

Sensor (mm)

Ø 12

Standard steel target (mm)

12 x 12 x 1

Operating zone (mm)

0...3.2 (flush mounted)

0...6.4 (not flush mounted)

Sensor (mm)

Ø 18

Standard steel target (mm)

24 x 24 x 1

Operating zone (mm)

0...6.4 (flush mounted)

0...12.8 (not flush mounted)

Sensor (mm)

Ø 30

Standard steel target (mm)

45 x 45 x 1

Operating zone (mm)

0...12 (flush mounted)

0...24 (not flush mounted)

Sensor (mm)

Ø 4 (1) and Ø 5 (2)

Standard steel target (mm)

Ø 4: 4.5 x 4.5 x 1

Ø 5: 5 x 5 x 1

Operating zone (mm)

0...0.65

— pick-up points  
- - - drop-out points (object approaching from the side)

#### Cubic, flat or rectangular type sensors

##### Flush mountable in metal

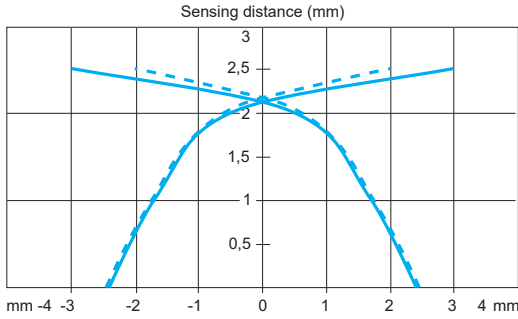

Sensor	Standard steel target (mm)	Operating zone (mm)
<b>XS7J1A1</b>	5 x 5 x 1	0...2
<i>— pick-up points</i> <i>- - - drop-out points (object approaching from the side)</i>		

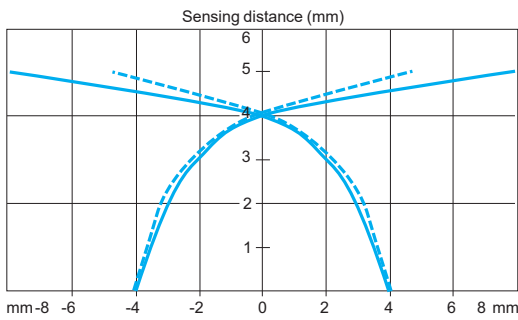

Sensor	Standard steel target (mm)	Operating zone (mm)
<b>XS7F1A1</b>	5 x 5 x 1	0...4
<i>— pick-up points</i> <i>- - - drop-out points (object approaching from the side)</i>		

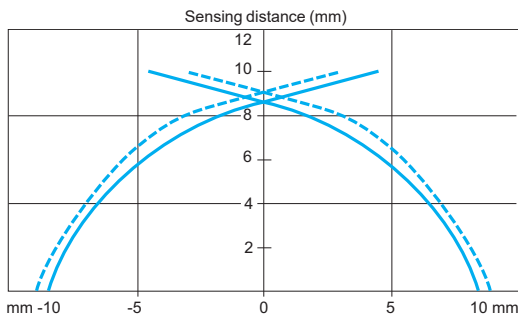

Sensor	Standard steel target (mm)	Operating zone (mm)
<b>XS7E1A1</b>	8 x 8 x 1	0...8
<i>— pick-up points</i> <i>- - - drop-out points (object approaching from the side)</i>		

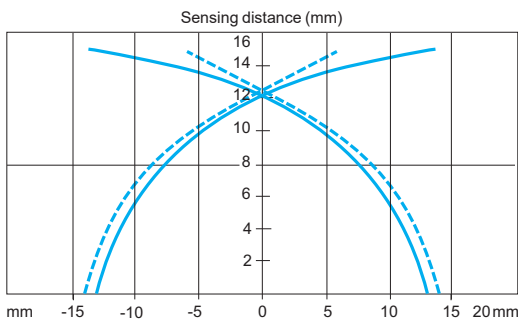

Sensor	Standard steel target (mm)	Operating zone (mm)
<b>XS7C1A1</b> <b>XS7C2A1</b>	18 x 18 x 1	0...12
<i>— pick-up points</i> <i>- - - drop-out points (object approaching from the side)</i>		

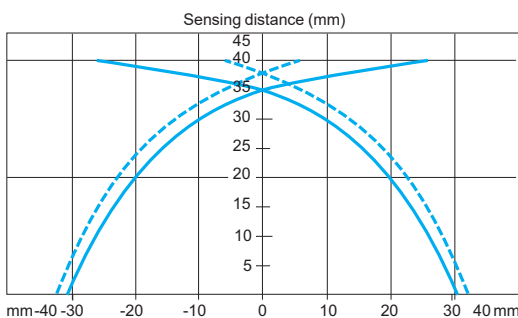

Sensor	Standard steel target (mm)	Operating zone (mm)
<b>XS7D1A1</b>	30 x 30 x 1	0...32
<i>— pick-up points</i> <i>- - - drop-out points (object approaching from the side)</i>		

### Cubic or rectangular type sensors, increased range

#### Flush mountable in metal

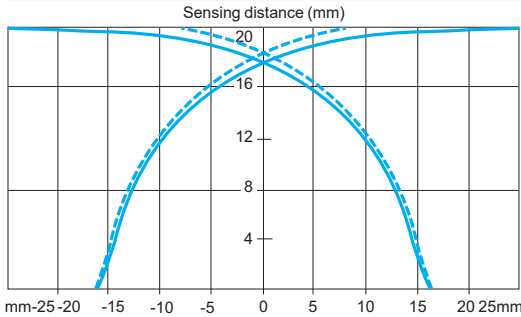

Sensor	Standard steel target (mm)	Operating zone (mm)
<b>XS8C●A1●</b>	30 x 30 x 1	0...16
— pick-up points - - - drop-out points (object approaching from the side)		

#### Non flush mountable in metal

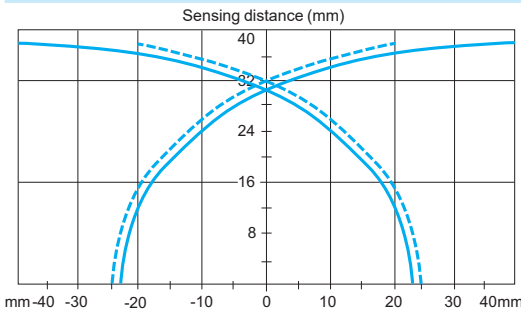

Sensor	Standard steel target (mm)	Operating zone (mm)
<b>XS8C●A4●</b>	45 x 45 x 1	0...32
— pick-up points - - - drop-out points (object approaching from the side)		

### Flat type sensors, increased range

#### Flush mountable in metal

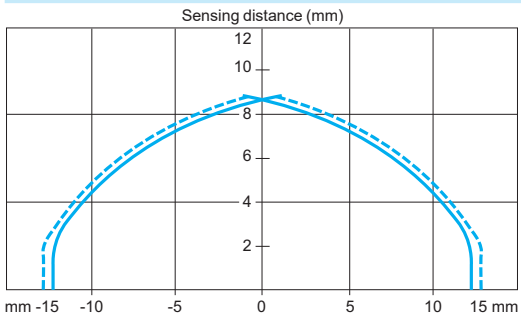

#### Non flush mountable in metal

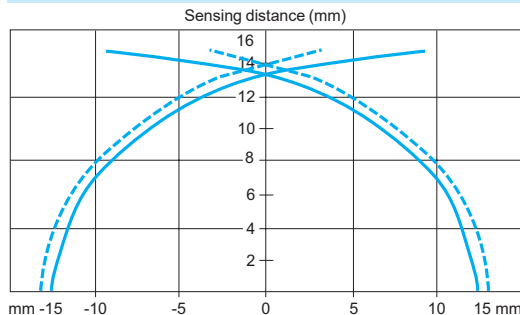

Sensor
<b>XS8E</b>
<b>Standard steel target (mm)</b>
18 x 18 x 1
<b>Operating zone (mm)</b>
5...10 (flush mounted) 5...15 (not flush mounted)

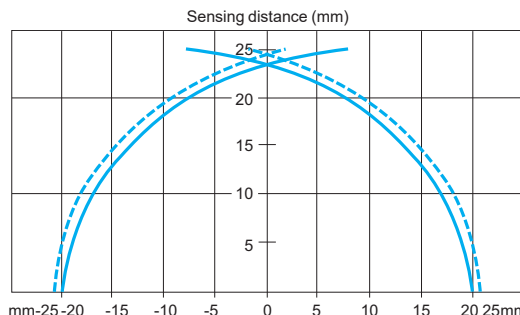
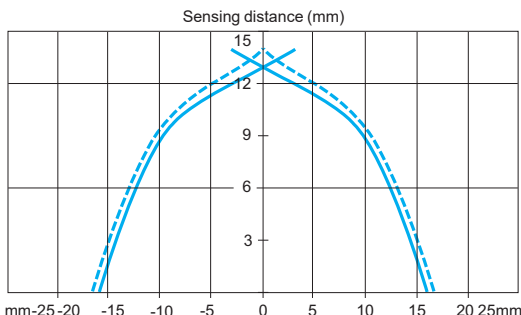

Sensor
<b>XS8C</b>
<b>Standard steel target (mm)</b>
30 x 30 x 1
<b>Operating zone (mm)</b>
8...15 (flush mounted) 8...25 (not flush mounted)

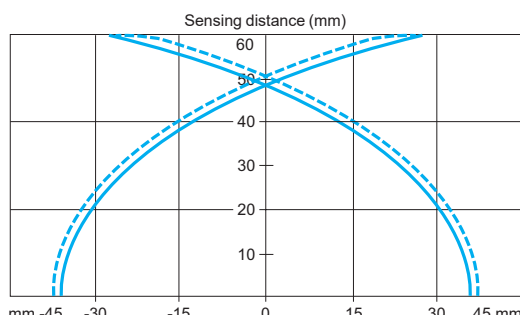
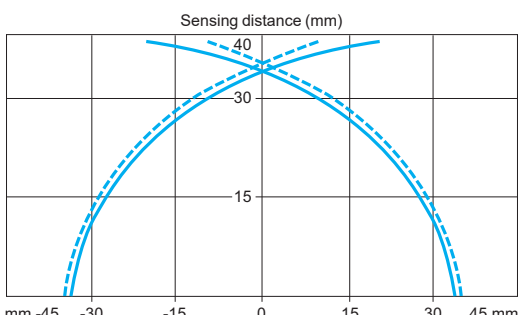

Sensor
<b>XS8D</b>
<b>Standard steel target (mm)</b>
45 x 45 x 1
<b>Operating zone (mm)</b>
20...40 (flush mounted) 0...60 (not flush mounted)

— pick-up points  
 - - - drop-out points (object approaching from the side)



# Substitution table

Sensors with the closest functionalities

# Inductive proximity sensors

Old sensor	New XS sensor	Old sensor	New XS sensor	Old sensor	New XS sensor
<b>Cylindrical type, DC (continued)</b>					
<b>XS2</b>					
XS2M08NA340	XS608B1NAL2	XS1M12NA370L1	XS512BLNAL5	XS2M12NA370D	XS612B1NAM12
XS2N08NA340	XS108B3NAL2	XS1M12NA370L2	XS512BLNAL10	XS2M12NA370L1	XS612B1NAL5
XS2N08NA340D	XS108B3NAM12	XS1M12NA370S	XS612B1NAM12 (2)	XS2M12NA370L2	XS612B1NAL10
XS2N08NA340L1	XS108B3NAL5	XS1M12NB370	XS512BLNBL2	XS2M12NB370	XS612B1NBL2
XS2N08NA340L2	XS108B3NAL10	XS1M12NB370D	XS512BLNBM12	XS2M12NB370D	XS612B1NBM12
XS2N08NA340S	XS108B3NAM8	XS1M12PA370	XS512BLPAL2	XS2M12PA370	XS612B1PAL2
XS2N08NB340	XS108B3NBL2	XS1M12PA370D	XS512BLPAM12	XS2M12PA370D	XS612B1PAM12
XS2N08NB340D	XS108B3NBM12	XS1M12PA370L1	XS512BLPAL5	XS2M12PA370L1	XS612B1PAL5
XS2N08NB340S	XS108B3NBM8	XS1M12PA370L2	XS512BLPAL10	XS2M12PA370L2	XS612B1PAL10
XS2N08PA340	XS108B3PAL2	XS1M12PA370LA	XS612B1PAL08U78	XS2M12PA370LA	XS612B1PAL08U78
XS2N08PA340D	XS108B3PAM12	XS1M12PA370LD	XS612B1PAL08M12	XS2M12PA370LD	XS612B1PAL08M12
XS2N08PA340L1	XS108B3PAL5	XS1M12PB370	XS512BLPBL2	XS2M12PB370	XS612B1PBL2
XS2N08PA340L2	XS108B3PAL10	XS1M12PB370D	XS512BLPBM12	XS2M12PB370D	XS612B1PBM12
XS2N08PA340S	XS108B3PAM8	XS1M12PB370L1	XS512BLPBL5	XS2M12PB370L1	XS612B1PBL5
XS2N08PB340	XS108B3PBL2	XS1M12PB370L2	XS512BLPBL10	XS2M12PB370S	XS612B1PBM12 (2)
XS2N08PB340D	XS108B3PBM12	XS1M12PB370LD	XS612B1PAM12 (1)		
XS2N08PB340S	XS108B3PBM8			XS2N12NA340	XS112B3NAL2
		XS1N12NA340	XS512B1NAL2	XS2N12NA340D	XS112B3NAM12
		XS1N12NA340D	XS512B1NAM12	XS2N12NA340L1	XS112B3NAL5
		XS1N12NA340L1	XS512B1NAL5	XS2N12NA340L2	XS112B3NAL10
		XS1N12NA340L2	XS512B1NAL10	XS2N12NB340	XS112B3NBL2
		XS1N12NB340	XS512B1NBL2	XS2N12NB340D	XS112B3NBM12
		XS1N12NB340D	XS512B1NBM12	XS2N12NC410L1	XS2N12NC410D + XZCPV1141L5
		XS1N12NC410L2	XS1N12NC410D + XZCPV1141L10	XS2N12PA340	XS112B3PAL2
			XS512B1PAL2	XS2N12PA340D	XS112B3PAM12
		XS1N12PA340	XS512B1PAM12	XS2N12PA340L1	XS112B3PAL5
		XS1N12PA340D	XS512B1PAM12	XS2N12PA340L2	XS112B3PAL10
		XS1N12PA340L1	XS512B1PAL5	XS2N12PC410	XS112B3PCL2
		XS1N12PA340L2	XS512B1PAL10	XS2N12PC410D	XS112B3PCM12
		XS1N12PA340LD	XS512B1PAM12 (1)	XS2N12PC410L1	XS112B3PCM12 + XZCPV1141L5
		XS1N12PA340S	XS512B1PAM12 (2)	XS2N12PC410L2	XS112B3PCM12 + XZCPV1141L10
		XS1N12PB340	XS512B1PBL2		
		XS1N12PB340D	XS512B1PBM12	XS2N12PB340	XS112B3PBL2
		XS1N12PB340L1	XS512B1PBL5	XS2N12PB340D	XS112B3PBM12
				XS2N12PB340L1	XS112B3PBL5
		XS1M12PA349D	XS612B1PAM12		
		XS1N12NA349	XS112B3NAL2	<b>XS3</b>	
		XS1N12NA349L1	XS112B3NAL5	XS3P12NA340	XS512B1NAL2 (3)
		XS1N12NA349D	XS112B3NAM12	XS3P12NA340D	XS512B1NAM12 (3)
		XS1N12NB349	XS112B3NBL2	XS3P12NA340L1	XS512B1NAL5 (3)
		XS1N12NB349L1	XS112B3NBL5	XS3P12PA340	XS512B1PAL2 (3)
		XS1N12NB349D	XS112B3NBM12	XS3P12PA340D	XS512B1PAM12 (3)
		XS1N12PA349	XS112B3PAL2	XS3P12PA340L1	XS512B1PAL5 (3)
		XS1N12PA349L1	XS112B3PAL5		
		XS1N12PA349D	XS112B3PAM12	XS3P12NA370	XS512BLNAL2 (3)
		XS1N12PB349	XS112B3PBL2	XS3P12NA370L1	XS512BLNAL5 (3)
		XS1N12PB349L1	XS112B3PBL5	XS3P12PA370	XS512BLPAL2 (3)
		XS1N12PB349D	XS112B3PBM12	XS3P12PA370L1	XS512BLPAL5 (3)
		<b>XS2</b>		<b>XS4</b>	
		XS2M12NA370	XS612B1NAL2	XS4P12PC410L2	XS4P12PC410D + XZCPV1141L10
<b>Diameter 12 mm</b>					
<b>XS1</b>					
XS1M12DA210	XS512B1DAL2				
XS1M12DA210D	XS512B1DAM12				
XS1M12DA210L1	XS512B1DAL5				
XS1M12DA210L2	XS512B1DAL10				
XS1M12DA210LA	XS512B1DAL08U78				
XS1M12DA210LD	XS512B1DAL08M12				
XS1M12DB210	XS512B1DBL2				
XS1M12DB210D	XS512B1DBM12				
XS1M12DB210L1	XS512B1DBL5				
XS1M12DB210L2	XS512B1DBL10				
XS1M12DB210LD	XS512B1DBL08M12				
XS1M12DA214D	XS512B1CAM12				
XS1M12DA214LD	XS512B1CAL08M12				
XS1M12NA370	XS512BLNAL2				
XS1M12NA370D	XS512BLNAM12				

(1) For the new sensor an integral M12 connector replaces the remote M12 connector on a 0.80 m flying lead.

(2) For the new sensor an M12 connector replaces the M8 connector.

(3) For the new sensor, the metal case replaces the plastic case.



# Substitution table

Sensors with the closest functionalities

# Inductive proximity sensors

Old sensor	New XS sensor	Old sensor	New XS sensor	Old sensor	New XS sensor
<b>Cylindrical type, DC (continued)</b>					
<b>Diameter 30 mm</b>					
<b>XS1</b>					
XS1M30DA210	XS530B1DAL2	XS1N30NA340	XS530B1NAL2	XS2M30PA370G	XS630B1PAL01G (4)
XS1M30DA210B	XS530B1DAL01B (4)	XS1N30NA340D	XS530B1NAM12	XS2M30PA370L1	XS630B1PAL5
XS1M30DA210C	XS530B1DAL01C (4)	XS1N30NA340L1	XS530B1NAL5	XS2M30PA370L2	XS630B1PAL10
XS1M30DA210D	XS530B1DAM12	XS1N30NA340L2	XS530B1NAL10	XS2M30PB370	XS630B1PBL2
XS1M30DA210G	XS530B1DAL01G (4)	XS1N30NB340	XS530B1NBL2	XS2M30PB370B	XS630B1PBL01B (4)
XS1M30DA210L1	XS530B1DAL5	XS1N30NB340D	XS530B1NBM12	XS2M30PB370C	XS630B1PBL01C (4)
XS1M30DA210L2	XS530B1DAL10	XS1N30PA340	XS530B1PAL2	XS2M30PB370D	XS630B1PBM12
XS1M30DA210LD	XS530B1DAL08M12	XS1N30PA340D	XS530B1PAM12	XS2M30PB370G	XS630B1PBL01G (4)
XS1M30DB210	XS530B1DBL2	XS1N30PA340L1	XS530B1PAL5	XS2M30PB370L1	XS630B1PBL5
XS1M30DB210B	XS530B1DBL01B (4)	XS1N30PA340L2	XS530B1PAL10	XS2M30PB370L2	XS630B1PBL10
XS1M30DB210D	XS530B1DBM12	XS1N30PB340	XS530B1PBL2		
XS1M30DB210LD	XS530B1DBM12 (1)	XS1N30PB340D	XS530B1PBM12		
		<b>XS2</b>		<b>XS3</b>	
		XS2N30NA340	XS130B3NAL2	XS3P30NA340	XS530B1NAL2 (3)
		XS2N30NA340D	XS130B3NAM12	XS3P30NA340D	XS530B1NAM12 (3)
XS1M30DA214D	XS530B1CAM12	XS2N30NA340L1	XS130B3NAL5	XS3P30NA340L1	XS530B1NAL5 (3)
XS1M30DA214LD	XS530B1CAL08M12	XS2N30NA340L2	XS130B3NAL10	XS3P30PA340	XS530B1PAL2 (3)
		XS2N30NB340	XS130B3NBL2	XS3P30PA340D	XS530B1PAM12 (3)
		XS2N30NC410L1	XS2N30NC410D + XZCPV1141L5	XS3P30PA340L1	XS530B1PAL5 (3)
XS1M30PA349D	XS630B1PAM12 (5)	XS2N30PC410	XS130B3PCL2	XS3P30PA340L2	XS530B1PAL10 (3)
		XS2N30PC410D	XS130B3PCM12		
		XS2N30PC410L1	XS130B3PCM12 + XZCPV1141L5		
XS1M30NA370	XS530BLNAL2	XS2N30NB340D	XS130B3NBM12	XS3P30PA370	XS530BLPAL2 (3)
XS1M30NA370B	XS630B1NAL01B (4)	XS2N30PA340	XS130B3PAL2	XS3P30PA370L1	XS530BLPAL5 (3)
XS1M30NA370C	XS630B1NAL01C (4)	XS2N30PA340D	XS130B3PAM12	XS3P30PA370L2	XS530BLPAL10 (3)
XS1M30NA370D	XS530BLNAM12	XS2N30PA340L1	XS130B3PAL5	XS3P30NA370	XS530BLNAL2 (3)
XS1M30NA370L1	XS530BLNAL5	XS2N30PA340L2	XS130B3PAL10	XS3P30NA370L1	XS530BLNAL5 (3)
XS1M30NA370L2	XS530BLNAL10	XS2N30PB340	XS130B3PBL2		
XS1M30NB370	XS530BLNBL2	XS2N30PB340D	XS130B3PBM12		
XS1M30NB370B	XS630B1NBL01B (4)				
XS1M30NB370C	XS630B1NBL01C (4)				
XS1M30NB370D	XS530BLNBM12				
XS1M30NB370L1	XS530BLNBL5	XS2M30NA370	XS630B1NAL2		
XS1M30NB370L2	XS530BLNBL10	XS2M30NA370B	XS630B1NAL01B (4)		
XS1M30PA370	XS530BLPAL2	XS2M30NA370C	XS630B1NAL01C (4)	<b>XS4</b>	
XS1M30PA370A	XS630B1PAL01U78 (4)	XS2M30NA370D	XS630B1NAM12	XS4P30NA370B	XS4P30NA370L01B (4)
XS1M30PA370B	XS630B1PAL01B (4)	XS2M30NA370L1	XS630B1NAL5	XS4P30NB370B	XS4P30NB370L01B (4)
XS1M30PA370C	XS630B1PAL01C (4)	XS2M30NA370L2	XS630B1NAL10	XS4P30NC410L2	XS4P30NC410D + XZCPV1141L10
XS1M30PA370D	XS530BLPAM12	XS2M30NB370	XS630B1NBL2	XS4P30PA370B	XS4P30PA370L01B (4)
XS1M30PA370G	XS630B1PAL01G (4)	XS2M30NB370B	XS630B1NBL01B (4)	XS4P30PB370B	XS4P30PB370L01B (4)
XS1M30PA370L1	XS530BLPAL5	XS2M30NB370C	XS630B1NBL01C (4)	XS4P30PC410L1	XS4P30PC410D + XZCPV1141L5
XS1M30PA370L2	XS530BLPAL10	XS2M30NB370D	XS630B1NBM12		
XS1M30PB370	XS530BLPBL2	XS2M30NB370L1	XS630B1NBL5	XS4P30PC410L2	XS4P30PC410D + XZCPV1141L10
XS1M30PB370B	XS630B1PBL01B (4)	XS2M30NB370L2	XS630B1NBL10		
XS1M30PB370C	XS630B1PBL01C (4)	XS2M30PA370	XS630B1PAL2		
XS1M30PB370D	XS530BLPBM12	XS2M30PA370A	XS630B1PAL01U78 (4)		
XS1M30PB370G	XS630B1PBL01G (4)	XS2M30PA370B	XS630B1PAL01B (4)		
XS1M30PB370L1	XS530BLPBL5	XS2M30PA370C	XS630B1PAL01C (4)		
XS1M30PB370L2	XS530BLPBL10	XS2M30PA370D	XS630B1PAM12		

(1) For the new sensor an integral M12 connector replaces the remote M12 connector on a 0.80 m flying lead.

(3) For the new sensor, the metal case replaces the plastic case.

(4) For the new sensor, connectors A, B, C and G on 0.1 m flying lead replace integral connectors A, B, C and G.

(5) For the new sensor, Sn = 15 mm instead of 20 mm.

# Substitution table

Sensors with the closest functionalities

# Inductive proximity sensors

Old sensor	New XS sensor	Old sensor	New XS sensor	Old sensor	New XS sensor
<b>Cylindrical type, AC or DC</b>		<b>Diameter 18 mm (continued)</b>		<b>Diameter 30 mm (continued)</b>	
<b>Diameter 12 mm</b>		<b>XS1</b>		<b>XS1M30MB230C</b>	
<b>XS1</b>				<b>XS1M30MB230G</b>	<b>XS630B1MBL01C (4)</b>
XS1M12MA230	<b>XS512B1MAL2</b>	XS1M18MA239A	<b>XS1M18MA239L01A (4)</b>	XS1M30MB230K	<b>XS630B1MBL01G (4)</b>
XS1M12MA230K	<b>XS512B1MAU20</b>	XS1M18MA239K	<b>XS618B1MAU20 (5)</b>	XS1M30MB230L1	<b>XS530B1MBU20</b>
XS1M12MA230L1	<b>XS512B1MAL5</b>			XS1M30MB230L2	<b>XS530B1MBL5</b>
XS1M12MA230L2	<b>XS512B1MAL10</b>	<b>XS2</b>			<b>XS530B1MBL10</b>
XS1M12MB230	<b>XS512B1MBL2</b>	XS2M18MA230	<b>XS618B1MAL2</b>	XS1M30MA239	<b>XS630B1MAL2 (5)</b>
XS1M12MB230K	<b>XS512B1MBU20</b>	XS2M18MA230A	<b>XS618B1MAL01U78 (4)</b>	XS1M30MA239A	<b>XS1M30MA239L01A (4)</b>
XS1M12MB230L1	<b>XS512B1MBL5</b>	XS2M18MA230B	<b>XS618B1MAL01B (4)</b>		
XS1M12MB230L2	<b>XS512B1MBL10</b>	XS2M18MA230C	<b>XS618B1MAL01C (4)</b>	<b>XS2</b>	
		XS2M18MA230G	<b>XS618B1MAL01G (4)</b>	XS2M30MA230	<b>XS630B1MAL2</b>
XS1M12MA239	<b>XS612B1MAL2</b>	XS2M18MA230K	<b>XS618B1MAU20</b>	XS2M30MA230A	<b>XS630B1MAL01U78 (4)</b>
XS1M12MA239K	<b>XS612B1MAU20</b>	XS2M18MA230L1	<b>XS618B1MAL5</b>	XS2M30MA230B	<b>XS630B1MAL01B (4)</b>
		XS2M18MB230	<b>XS618B1MAL10</b>	XS2M30MA230C	<b>XS630B1MAL01C (4)</b>
<b>XS2</b>		XS2M18MB230A	<b>XS618B1MBL2</b>	XS2M30MA230G	<b>XS630B1MAL01G (4)</b>
XS2M12MA230	<b>XS612B1MAL2</b>	XS2M18MB230B	<b>XS618B1MBL01U78 (4)</b>	XS2M30MA230K	<b>XS630B1MAU20</b>
XS2M12MA230K	<b>XS612B1MAU20</b>	XS2M18MB230C	<b>XS618B1MBL01B (4)</b>	XS2M30MA230L1	<b>XS630B1MAL5</b>
XS2M12MA230L1	<b>XS612B1MAL5</b>	XS2M18MB230G	<b>XS618B1MBL01C (4)</b>	XS2M30MA230L2	<b>XS630B1MAL10</b>
XS2M12MA230L2	<b>XS612B1MAL10</b>	XS2M18MB230K	<b>XS618B1MBU20</b>	XS2M30MB230	<b>XS630B1MBL2</b>
XS2M12MB230	<b>XS612B1MBL2</b>	XS2M18MB230L1	<b>XS618B1MBL5</b>	XS2M30MB230A	<b>XS630B1MBL01U78 (4)</b>
XS2M12MB230K	<b>XS612B1MBU20</b>	XS2M18MB230L2	<b>XS618B1MBL10</b>	XS2M30MB230B	<b>XS630B1MBL01B (4)</b>
XS2M12MB230L1	<b>XS612B1MBL5</b>			XS2M30MB230C	<b>XS630B1MBL01C (4)</b>
XS2M12MB230L2	<b>XS612B1MBL10</b>	<b>XS3</b>		XS2M30MB230G	<b>XS630B1MBL01G (4)</b>
		XS3P18MA230	<b>XS618B1MAL2 (3)</b>	XS2M30MB230K	<b>XS630B1MAU20</b>
		XS3P18MA230K	<b>XS618B1MAU20 (3)</b>	XS2M30MB230L1	<b>XS630B1MBL5</b>
		XS3P18MA230L1	<b>XS618B1MAL5 (3)</b>	XS2M30MB230L2	<b>XS630B1MBL10</b>
		XS3P18MA230L2	<b>XS618B1MAL10 (3)</b>		
		XS3P18MB230	<b>XS618B1MBL2 (3)</b>	<b>XS3</b>	
		XS3P18MB230A	<b>XS618B1MBU20 (3)</b>	XS3P30MA230	<b>XS630B1MAL2 (3)</b>
		XS3P18MB230K	<b>XS618B1MBL01B (4)</b>	XS3P30MA230K	<b>XS630B1MAU20 (3)</b>
		XS3P18MB230L1	<b>XS618B1MBL01C (4)</b>	XS3P30MA230L1	<b>XS630B1MAL5 (3)</b>
		XS3P18MB230L2	<b>XS618B1MBL01G (4)</b>	XS3P30MA230L2	<b>XS630B1MAL10 (3)</b>
				XS3P30MB230	<b>XS630B1MBL2 (3)</b>
				XS3P30MB230K	<b>XS630B1MBU20 (3)</b>
				XS3P30MB230L1	<b>XS630B1MBL5 (3)</b>
<b>Diameter 18 mm</b>					
<b>XS1</b>					
XS1M18MA230	<b>XS518B1MAL2</b>	XS4P18MA230B	<b>XS4P18MA230L01B (4)</b>	<b>XS4</b>	
XS1M18MA230A	<b>XS618B1MAL01U78 (4)</b>	XS4P18MA230C	<b>XS4P18MA230L01C (4)</b>	XS4P30MA230B	<b>XS4P30MA230L01B (4)</b>
XS1M18MA230B	<b>XS618B1MAL01B (4)</b>	XS4P18MA230G	<b>XS4P18MA230L01G (4)</b>	XS4P30MA230C	<b>XS4P30MA230L01C (4)</b>
XS1M18MA230C	<b>XS618B1MAL01C (4)</b>	XS4P18MB230B	<b>XS4P18MB230L01B (4)</b>	XS4P30MA230G	<b>XS4P30MA230L01G (4)</b>
XS1M18MA230G	<b>XS618B1MAL01G (4)</b>	XS4P18MB230C	<b>XS4P18MB230L01C (4)</b>	XS4P30MB230B	<b>XS4P30MB230L01B (4)</b>
XS1M18MA230K	<b>XS518B1MAU20</b>			XS4P30MB230C	<b>XS4P30MB230L01C (4)</b>
XS1M18MA230L1	<b>XS518B1MAL5</b>	<b>Diameter 30 mm</b>			
XS1M18MA230L2	<b>XS518B1MAL10</b>	<b>XS1</b>			
XS1M18MB230	<b>XS518B1MBL2</b>	XS1M30MA230	<b>XS530B1MAL2</b>		
XS1M18MB230A	<b>XS618B1MBL01U78 (4)</b>	XS1M30MA230A	<b>XS630B1MAL01U78 (4)</b>		
XS1M18MB230B	<b>XS618B1MBL01B (4)</b>	XS1M30MA230B	<b>XS630B1MAL01B (4)</b>		
XS1M18MB230C	<b>XS618B1MBL01C (4)</b>	XS1M30MA230C	<b>XS630B1MAL01C (4)</b>		
XS1M18MB230G	<b>XS618B1MBL01G (4)</b>	XS1M30MA230G	<b>XS630B1MAL01G (4)</b>		
XS1M18MB230K	<b>XS518B1MBU20</b>	XS1M30MA230K	<b>XS530B1MAU20</b>		
XS1M18MB230L1	<b>XS518B1MBL5</b>	XS1M30MA230L1	<b>XS530B1MAL5</b>		
XS1M18MB230L2	<b>XS518B1MBL10</b>	XS1M30MA230L2	<b>XS530B1MAL10</b>		
XS1M18MA239	<b>XS618B1MAL2 (5)</b>	XS1M30MB230	<b>XS530B1MBL2</b>		
		XS1M30MB230A	<b>XS630B1MBL01U78 (4)</b>		
		XS1M30MB230B	<b>XS630B1MBL01B (4)</b>		

(3) For the new sensor, the metal case replaces the plastic case.

(4) For the new sensor, connectors A, B, C and G on 0.1 m flying lead replace integral connectors A, B, C and G.

(5) For the new sensor, Sn = 8 mm instead of 10 mm.

# Substitution table

Sensors with the closest functionalities

# Inductive proximity sensors

Old sensor	New XS sensor	Old sensor	New XS sensor
<b>Block type</b>		<b>40 x 40 x 70 mm and 40 x 40 x 117 mm (continued)</b>	
<b>40 x 40 x 70 mm and 40 x 40 x 117 mm</b>		<b>XS8</b>	
<b>XS7</b>		XS8C40DA210	XS8C4A1DPG13
XS7C40DA210	XS7C4A1DPG13	XS8C40DA210H29	XS8C4A1DPP20
XS7C40DA210A	XS7C4A1DPU78	XS8C40DA214D	XS8C4A1DPM12
XS7C40DA210D	XS7C4A1DPM12	XS8C40DP210	XS8C4A1DPG13
XS7C40DA210H29	XS7C4A1DPP20	XS8C40DP210H29	XS8C4A1DPP20
XS7C40DA210H7	XS7C4A1DPN12	XS8C40DP210H7	XS8C4A1DPN12
XS7C40DA214D	XS7C4A1DPM12	XS8C40FP260	XS8C4A1MPG13
XS7C40DP210	XS7C4A1DPG13	XS8C40FP260H29	XS8C4A1MPP20
XS7C40DP210H29	XS7C4A1DPP20	XS8C40FP260H7	XS8C4A1MPN12
XS7C40DP210H7	XS7C4A1DPN12	XS8C40MP230	XS8C4A1MPG13
XS7C40FP260	XS7C4A1MPG13	XS8C40MP230H29	XS8C4A1MPP20
XS7C40FP260A	XS7C4A1MPU78	XS8C40MP230H7	XS8C4A1MPN12
XS7C40FP260H29	XS7C4A1MPP20	XS8C40NC440	XS8C4A1NCG13
XS7C40FP260H7	XS7C4A1MPN12	XS8C40NC440H29	XS8C4A1NCP20
XS7C40KPM40	XS9C4A1PCG13	XS8C40NC449	XS8C4A4NCG13
XS7C40KPM40H29	XS9C4A1PCP20	XS8C40NC449H29	XS8C4A4NCP20
XS7C40KPM40H7	XS9C4A1PCN12	XS8C40NC449H7	XS8C4A4NCN12
XS7C40MP230	XS7C4A1MPG13	XS8C40PC440	XS8C4A1PCG13
XS7C40MP230A	XS7C4A1MPU78	XS8C40PC440D	XS8C4A1PCM12
XS7C40MP230H29	XS7C4A1MPP20	XS8C40PC440H29	XS8C4A1PCP20
XS7C40MP230H7	XS7C4A1MPN12	XS8C40PC440H7	XS8C4A1PCN12
XS7C40NC440	XS8C4A1NCG13	XS8C40PC449	XS8C4A4PCG13
XS7C40NC440D	XS8C4A1NCM12	XS8C40PC449D	XS8C4A4PCM12
XS7C40NC440H29	XS8C4A1NCP20	XS8C40PC449H29	XS8C4A4PCP20
XS7C40NC440H7	XS8C4A1NCN12	XS8C40PC449H7	XS8C4A4PCN12
XS7C40NC449	XS8C4A1NCG13	XS8T4NC440	XS8C2A1NCM12 + XZCP1141L2
XS7C40NC449H29	XS8C4A1NCP20	XS8T4NC440LD01	XS8C2A1NCM12
XS7C40NC449H7	XS8C4A1NCN12	XS8T4PC440	XS8C2A1PCM12 + XZCP1141L2
XS7C40PC440	XS8C4A1PCG13	XS8T4PC440L1	XS8C2A1PCM12 + XZCP1141L5
XS7C40PC440D	XS8C4A1PCM12	XS8T4PC440L2	XS8C2A1PCM12 + XZCP1141L10
XS7C40PC440H29	XS8C4A1PCP20	XS8T4PC440LD	XS8C2A1PCM12
XS7C40PC440H7	XS8C4A1PCN12	XS8T4PC440LD01	XS8C2A1PCM12
XS7C40PC449	XS8C4A1PCG13		
XS7C40PC449D	XS8C4A1PCM12		
XS7C40PC449H29	XS8C4A1PCP20		
XS7C40PC449H7	XS8C4A1PCN12		
XS7T4DA210	XS7C2A1DAM12 + XZCP1141L2		
XS7T4DA214LD	XS8C2A1CAM12		
XS7T4DA214LD01	XS8C2A1CAM12		
XS7T4DA214LD01W	XS8C2A1CAM12 + XSZPKC2		
XS7T4DA214LDW	XS8C2A1CAM12 + XSZPKC2		
XS7T4NC440	XS8C2A1NCM12 + XZCP1141L2		
XS7T4NC440LD	XS8C2A1NCM12		
XS7T4NC440LD01	XS8C2A1NCM12		
XS7T4PC440	XS8C2A1PCM12 + XZCP1141L2		
XS7T4PC440LD	XS8C2A1PCM12		
		<b>40 x 40 x 117 mm</b>	
		<b>XSCH</b>	
		XSCH203629	XS9C4A2A2G13
		XSCH203629H7	XS9C4A2A2N12
		XSCH207629	XS9C4A2A1G13
		XSCH207629H7	XS9C4A2A1N12

<b>X</b>					
XS1L04NA310	74	XS1N18PA349	70	XS4P18NA370	68
XS1L04NA310S	74	XS1N18PA349D	70	XS4P18PA340	68
XS1L04NA311	74	XS1N18PB349	70	XS4P18PA370	68
XS1L04NA311S	74	XS1N18PB349D	70	XS4P18PB340	68
XS1L04NB310	74	XS1N18PC410	61	XS4P18PB370	68
XS1L04NB310S	74	XS1N18PC410D	61	XS4P18PC410	61
XS1L04NB311	74	XS1N30NA349	70	XS4P18PC410D	61
XS1L04NB311S	74	XS1N30NA349D	70	XS4P30AB110	85
XS1L04PA310	74	XS1N30PA349	70	XS4P30AB120	85
XS1L04PA310S	74	XS1N30PA349D	70	XS4P30KP340	66
XS1L04PA311	74	XS1N30PB349	70	XS4P30KP340D	66
XS1L04PA311S	74	XS1N30PB349D	70	XS4P30MA230	68
XS1L04PB310	74	XS1N30PC410	61	XS4P30MA230K	68
XS1L04PB310S	74	XS1N30PC410D	61	XS4P30MB230	68
XS1L04PB311	74	XS2M08PC410	60	XS4P30MB230K	68
XS1L04PB311S	74	XS2M08PC410D	60	XS4P30NA340	68
XS1L06PC410	60	XS2M12KP340	66	XS4P30PA340	68
XS1M08PC410	60	XS2M12KP340D	66	XS4P30PA370	68
XS1M08PC410D	60	XS2M18KP340	66	XS4P30PB340	68
XS1M12AB120	83	XS2M18KP340D	66	XS4P30PB370	68
XS1M12KP340	66	XS2M18MA250	58	XS4P30PC410	61
XS1M12KP340D	66	XS2M18MA250K	58	XS4P30PC410D	61
XS1M18AB120	84	XS2M18MB250	58	XS5ppBSPDL2	113
XS1M18KP340	66	XS2M18MB250K	58	XS5ppBSPDM12	113
XS1M18KP340D	66	XS2M30KP340	66	XS7C1A1DAL2	50
XS1M18MA250	58	XS2M30KP340D	66	XS7C1A1DAM8	50
XS1M18MA250K	58	XS2M30MA250	58	XS7C1A1DBL01M12	50
XS1M18MB250	58	XS2M30MA250K	58	XS7C1A1NBL2	50
XS1M18MB250K	58	XS2M30MB250	58	XS7C1A1NBM8	50
XS1M18PAS20D	110	XS2M30MB250K	58	XS7C1A1PAL01M12	50
XS1M18PAS40D	110	XS2N12PC140	60	XS7C1A1PAL2	50
XS1M30AB120	85	XS4P08MA230	68	XS7C1A1PAM8	50
XS1M30KP340	66	XS4P08MB230	68	XS7C1A1PBL2	50
XS1M30KP340D	66	XS4P08NA340	68	XS7C1A1PBM8	50
XS1M30MA250	58	XS4P08NB340	68	XS7C2A1DAM12	54
XS1M30MA250K	58	XS4P08PA340	68	XS7C2A1DBM12	54
XS1M30MB250	58	XS4P08PB340	68	XS7C2A1NAM12	54
XS1M30MB250K	58	XS4P08PC410	60	XS7C2A1NBM12	54
XS1N05NA310	74	XS4P12AB110	83	XS7C2A1PAM12	54
XS1N05NA311	74	XS4P12AB120	83	XS7C2A1PBM12	54
XS1N05NA311S	74	XS4P12KP340	66	XS7C4A1DPP20	56
XS1N05NB310	74	XS4P12KP340D	66	XS7C4A1MPP20	56
XS1N05NB311	74	XS4P12MA230	68	XS7D1A1DAL2	50
XS1N05NB311S	74	XS4P12MA230K	68	XS7D1A1DAM12	50
XS1N05PA310	74	XS4P12MB230	68	XS7D1A1DBL2	50
XS1N05PA311	74	XS4P12NA340	68	XS7D1A1NAL2	50
XS1N05PA311S	74	XS4P12NA370	68	XS7D1A1PAL2	50
XS1N05PB310	74	XS4P12NB340	68	XS7D1A1PAM12	50
XS1N05PB311	74	XS4P12PA340	68	XS7D1A1PBM12	50
XS1N05PB311S	74	XS4P12PA370	68	XS7D1A3CAM12DIN	104
XS1N12NA349	70	XS4P12PB370	68	XS7E1A1CAL01M12	50
XS1N12NA349D	70	XS4P12PC410	60	XS7E1A1DAL01M12	50
XS1N12NC410	60	XS4P12PC410D	60	XS7E1A1DAL2	50
XS1N12NC410D	60	XS4P18AB110	84	XS7E1A1NAL2	50
XS1N12PA349	70	XS4P18AB120	84	XS7E1A1NBL2	50
XS1N12PA349D	70	XS4P18KP340	66	XS7E1A1PAL01M12	50
XS1N12PB349	70	XS4P18KP340D	66	XS7E1A1PAL2	50
XS1N12PB349D	70	XS4P18MA230	68	XS7E1A1PAM8	50
XS1N12PC410	60	XS4P18MA230K	68	XS7E1A1PBL01M12	50
XS1N12PC410D	60	XS4P18MB230	68	XS7E1A1PBL2	50
XS1N18NA349	70	XS4P18MB230K	68	XS7E1A1PBM8	50
XS1N18NA349D	70	XS4P18NA340	68	XS7F1A1DAL2	48
				XS7F1A1DBL01M8	48
				XS7F1A1DBL2	48
				XS7F1A1NAL2	48
				XS7F1A1NBL2	48
				XS7F1A1PAL01M8	48
				XS7F1A1PAL2	48
				XS7F1A1PBL01M8	48
				XS7F1A1PBL2	48
				XS7J1A1DAL2	48
				XS7J1A1NAL01M8	48
				XS7J1A1NAL2	48
				XS7J1A1NBL2	48
				XS7J1A1PAL01M8	48
				XS7J1A1PAL2	48
				XS7J1A1PBL01M8	48
				XS7J1A1PBL2	48
				XS8C1A1MAL01U20	52
				XS8C1A1MAL2	52
				XS8C1A1MBL01U20	52
				XS8C1A1MBL2	52
				XS8C1A1NAL2	52
				XS8C1A1PAL01M12	52
				XS8C1A1PAL2	52
				XS8C1A1PAM8	52
				XS8C1A1PBL2	52
				XS8C1A1PBM8	52
				XS8C2A1DAM12	54
				XS8C2A1MAU20	54
				XS8C2A1MBU20	54
				XS8C2A1NCM12	54
				XS8C2A1PCM12	54
				XS8C2A1PDM12	116
				XS8C2A4CAM12	54
				XS8C2A4DAM12	54
				XS8C2A4MAU20	54
				XS8C2A4MBU20	54
				XS8C2A4NCM12	54
				XS8C2A4PCM12	54
				XS8C2A4PDM12	116
				XS8C4A1DPP20	56
				XS8C4A1MPP20	56
				XS8C4A1NCP20	56
				XS8C4A1PCP20	56
				XS8C4A4DPP20	56
				XS8C4A4MPP20	56
				XS8C4A4NCP20	56
				XS8C4A4PCM12	56
				XS8C4A4PCP20	56
				XS8C4A4PDP20	118
				XS8D1A1MAL2	52
				XS8D1A1MAU20	52
				XS8D1A1MBL2	52
				XS8D1A1MBU20	52
				XS8D1A1NAL2	52
				XS8D1A1PAL2	52
				XS8D1A1PAM12	52
				XS8D1A1PBL2	52
				XS8D1A1PBM12	52
				XS8E1A1MAL01U20	52
				XS8E1A1MAL2	52
				XS8E1A1MBL01U20	52
				XS8E1A1MBL2	52
				XS8E1A1NAL2	52
				XS8E1A1NBL2	52
				XS8E1A1NBM8	52
				XS8E1A1PAL01M12	52
				XS8E1A1PAL2	52
				XS8E1A1PAM8	52
				XS8E1A1PBL2	52
				XS8E1A1PBM8	52
				XS9C2A1NCM12	108
				XS9C2A1PCM12	108
				XS9C2A2A1M12	90
				XS9C2A2A2M12	90
				XS9C4A1PCP20	108
				XS9C4A2A2P20	90
				XS9C11RMBL01U20	81
				XS9C111A1L2	87
				XS9C111A2L2	89
				XS9D111A2L2	89
				XS9E11RMBL01U20	81
				XS9E11RPBL01M12	81
				XS9E111A1L2	87
				XS9E111A2L2	89
				XS106B3PAL2	34
				XS106B3PAM8	34
				XS106B3PAM12	34
				XS106B3PBL2	34
				XS106B3PBM8	34
				XS108B3NAL2	34
				XS108B3NAM8	34
				XS108B3NAM12	34
				XS108B3NBM8	34
				XS108B3PAL2	34
				XS108B3PAM8	34
				XS108B3PAM12	34
				XS108B3PBL2	34
				XS108B3PBM8	34
				XS108B3PBM12	34
				XS112B3NAL2	34
				XS112B3NAM12	34
				XS112B3PAL2	34
				XS112B3PAM12	34
				XS112B3PBL2	34
				XS112B3PBM12	34
				XS112B3PCL2	64
				XS112B3PCM12	64
				XS112B3PDL2	114
				XS112B3PDM12	114
				XS118B3NAL2	35
				XS118B3NAM12	35
				XS118B3PAL2	35
				XS118B3PAM12	35
				XS118B3PBL2	35
				XS118B3PBM12	35
				XS118B3PCL2	64
				XS118B3PCM12	64
				XS118B3PDL2	114
				XS118B3PDM12	114
				XS130B3NAL2	35
				XS130B3NAM12	35
				XS130B3PAL2	35
				XS130B3PAM12	35
				XS130B3PBL2	35
				XS130B3PBM12	35
				XS130B3PCL2	64

XS130B3PCM12	64	XS505R1PBL2	72	XS518B1PBL2	24	XS608B1PCL2	64	XS618B2PAL01M12	76
XS130B3PDL2	114	XS505R1PBM08	72	XS518B1PBM12	24	XS608B1PCM12	64	XS618B2PBL01M12	76
XS130B3PDM12	114	XS506B1NAL2	24	XS518BLNAL2	25	XS608B3CAL2	38	XS618B3DAL2	38
XS212AANAL2	98	XS506B1NAM8	24	XS518BLPAL2	25	XS608B4NAL2	42	XS618B3DAM12	38
XS212AANAM12	98	XS506B1NBL2	24	XS518BLPAM12	25	XS608B4NAM8	42	XS618B3DBL2	38
XS212AAPAL2	98	XS506B1NBM8	24	XS518BLPBL2	25	XS608B4NAM12	42	XS618B3DBM12	38
XS212AAPAM12	98	XS506B1PAL2	24	XS518BLPBM12	25	XS608B4NBL2	42	XS618B4MAL2	46
XS212B4NAL2	44	XS506B1PAM8	24	XS518BSDAM12	28	XS608B4NBM8	42	XS618B4MAU20	46
XS212B4NAM12	44	XS506B1PAM12	24	XS518BSPDL2	112	XS608B4NBM12	42	XS618B4MBL2	46
XS212B4NBL2	44	XS506B1PBL2	24	XS518BSPDM12	112	XS608B4PAL2	42	XS618B4MBU20	46
XS212B4PAL2	44	XS506B1PBM8	24	XS530B1CAM12	29	XS608B4PAM8	42	XS618B4NAL2	42
XS212B4PAL5	44	XS508B1CAL08M12	29	XS530B1DAL2	29	XS608B4PAM12	42	XS618B4NAM12	42
XS212B4PAM12	44	XS508B1DAL2	29	XS530B1DAM12	29	XS608B4PBL2	42	XS618B4NBL2	42
XS212B4PBL2	44	XS508B1DAM12	29	XS530B1DBL2	29	XS608B4PBM8	42	XS618B4PAL2	42
XS212B4PBM12	44	XS508B1NAL2	24	XS530B1MAL2	32	XS608B4PBM12	42	XS618B4PAM12	42
XS212SANAL2	94	XS508B1NAM8	24	XS530B1MAU20	32	XS612B1DAL2	38	XS618B4PBL2	42
XS212SANAM12	94	XS508B1PAL2	24	XS530B1MBL2	32	XS612B1DAM12	38	XS618B4PBM12	42
XS212SAPAL2	94	XS508B1PAM8	24	XS530B1NAL2	24	XS612B1DBM12	38	XS630B1DAL2	38
XS212SAPAM12	94	XS508B1PAM12	24	XS530B1NAM12	24	XS612B1MAL2	40	XS630B1DAM12	38
XS218AAMAL2	100	XS508B1PBL2	24	XS530B1PAL2	24	XS612B1MAU20	40	XS630B1DBM12	38
XS218AAMAU20	100	XS508B1PBM8	24	XS530B1PAM12	24	XS612B1MBL2	40	XS630B1MAL01B	40
XS218AANAL2	98	XS508B1PBM12	24	XS530B1PBL2	24	XS612B1MBU20	40	XS630B1MAL01C	40
XS218AANAM12	98	XS508BLNBM12	25	XS530B1PBM12	24	XS612B1NAL2	36	XS630B1MAL01U78	40
XS218AAPAL2	98	XS508BLPAL2	25	XS530BLPAL2	25	XS612B1NAM12	36	XS630B1MAL2	40
XS218AAPAM12	98	XS508BLPAM12	25	XS530BLPAM12	25	XS612B1NBL2	36	XS630B1MAU20	40
XS218B4NAL2	44	XS508BLPBM12	25	XS530BLPBL2	25	XS612B1NBM12	36	XS630B1MBL01B	40
XS218B4NAM12	44	XS508BSCBL2	28	XS530BSCAM12	28	XS612B1PAL2	36	XS630B1MBL2	40
XS218B4PAL2	44	XS512B1CAL08M12	29	XS530BSPDL2	112	XS612B1PAM12	36	XS630B1MBU20	40
XS218B4PAM12	44	XS512B1CAM12	29	XS530BSPDM12	112	XS612B1PBL2	36	XS630B1NAL2	36
XS218B4PBL2	44	XS512B1DAL2	29	XS604R1NAL2	72	XS612B1PBM12	36	XS630B1NAM12	36
XS218B4PBM12	44	XS512B1DAM12	29	XS604R1NAM08	72	XS612B2PAL01M12	76	XS630B1NBL2	36
XS218SAMAL2	96	XS512B1DBL2	29	XS604R1NBL2	72	XS612B2PBL01M12	76	XS630B1PAL01C	36
XS218SAMAU20	96	XS512B1MAL2	32	XS604R1NBM08	72	XS612B3DAL2	38	XS630B1PAL2	36
XS218SANAL2	94	XS512B1MAU20	32	XS604R1PAL2	72	XS612B3DAM12	38	XS630B1PAM12	36
XS218SANAM12	94	XS512B1MBL2	32	XS604R1PAM08	72	XS612B3DBL2	38	XS630B1PBL2	36
XS218SAPAL2	94	XS512B1MBU20	32	XS604R1PBL2	72	XS612B3DBM12	38	XS630B1PBM12	36
XS218SAPAM12	94	XS512B1NAL2	24	XS604R1PBM08	72	XS612B4NAL2	42	XS630B2PAL01M12	76
XS230AAMAL2	100	XS512B1NAM12	24	XS605R1NAL2	72	XS612B4NAM12	42	XS630B3DAL2	38
XS230AAMAU20	100	XS512B1PAL2	24	XS605R1NAM08	72	XS612B4NBL2	42	XS630B3DAM12	38
XS230AANAL2	98	XS512B1PAM12	24	XS605R1NBL2	72	XS612B4PAL2	42	XS630B4MAL2	46
XS230AANAM12	98	XS512B1PBL2	24	XS605R1NBM08	72	XS612B4PAM12	42	XS630B4MAU20	46
XS230AAPAL2	98	XS512B1PBM12	24	XS605R1PAL2	72	XS612B4PBL2	42	XS630B4MBL2	46
XS230AAPAM12	98	XS512BLPAL2	25	XS605R1PAL5	72	XS612B4PBM12	42	XS630B5NAL2	42
XS230SAMAL2	96	XS512BLPAM12	25	XS605R1PAM08	72	XS618B1DAL2	38	XS630B5PAL2	42
XS230SAMAU20	96	XS512BLPBL2	25	XS605R1PBL2	72	XS618B1DAM12	38	XS630B5PAM12	42
XS230SANAL2	94	XS512BSDAM12	28	XS605R1PBM08	72	XS618B1DBL2	38	XS630B5PBM12	42
XS230SANAM12	94	XS512BSPDL2	112	XS606B1DBL2	38	XS618B1DBM12	38	XS908R1PAM12	102
XS230SAPAL2	94	XS512BSPDM12	112	XS606B3CAL2	38	XS618B1MAL01B	40	103	
XS230SAPAM12	94	XS518B1CAL08M12	29	XS606B3CBL2	38	XS618B1MAL01C	40	XS908R4PAM12	102
XS504R1NAL2	72	XS518B1CAM12	29	XS608B1DAL2	38	XS618B1MAL01U78	40	103	
XS504R1NAM08	72	XS518B1DAL01C	29	XS608B1DAM12	38	XS618B1MAL2	40	XS912R1PAM12	102
XS504R1NBL2	72	XS518B1DAL2	29	XS608B1DBL2	38	XS618B1MAU20	40	103	
XS504R1NBM08	72	XS518B1DAM12	29	XS608B1NAL2	36	XS618B1MBL2	40	XS912R4PAM12	102
XS504R1PAL2	72	XS518B1DBL2	29	XS608B1NAM8	36	XS618B1MBU20	40	103	
XS504R1PAM08	72	XS518B1DBM12	29	XS608B1NAM12	36	XS618B1NAL2	36	XS912RWPAM12	106
XS504R1PBL2	72	XS518B1MAL2	32	XS608B1NBL2	36	XS618B1NAM12	36	107	
XS504R1PBM08	72	XS518B1MAU20	32	XS608B1NBM8	36	XS618B1NBL2	36	XS912S1PAM12	92
XS505R1NAL2	72	XS518B1MBL2	32	XS608B1PAL2	36	XS618B1NBM12	36	93	
XS505R1NAM08	72	XS518B1MBU20	32	XS608B1PAM8	36	XS618B1PAL01C	36	XS912S4PAM12	92
XS505R1NBL2	72	XS518B1NAL2	24	XS608B1PAM12	36	XS618B1PAL2	36	93	
XS505R1NBM08	72	XS518B1NAM12	24	XS608B1PBL2	36	XS618B1PAL2	36	XS918R1PAM12	102
XS505R1PAL2	72	XS518B1PAL2	24	XS608B1PBM8	36	XS618B1PBL2	36	103	
XS505R1PAM08	72	XS518B1PAM12	24	XS608B1PBM12	36	XS618B1PBM12	36	XS918R4PAM12	102
								103	
								XS918RWPAM12	106
								107	





[www.telemecaniquesensors.com](http://www.telemecaniquesensors.com)

The information provided in this catalogue contains description of products sold by TMSS France, its subsidiaries and other affiliated companies ('Offer') with technical specifications and technical characteristics of the performance of the corresponding Offer.

The content of this document is subject to revision at any time without notice due to continued progress in methodology, design and manufacturing.

To the extent permitted by applicable law, no responsibility or liability is assumed by TMSS France, its subsidiaries and other affiliated companies for any type of damage arising out of or in connexion with (a) informational content of this catalogue not conforming with or exceeding the technical specifications, or (b) any error contained in this catalogue, or (c) any use, decision, act or omission made or taken on the basis of or in reliance on any information contained or referred to in this catalogue.

**NEITHER TMSS FRANCE, ITS SUBSIDIARIES, NOR ITS OTHER AFFILIATES, AS THE CASE MAYBE, MAKE NO WARRANTY OR REPRESENTATION OF ANY KIND, WHETHER EXPRESS OR IMPLIED, AS TO WHETHER THIS CATALOGUE OR ANY INFORMATION CONTAINED THEREIN SUCH AS PRODUCTS WILL MEET REQUIREMENTS, EXPECTATIONS OR PURPOSE OF ANY PERSON MAKING USE THEREOF.**

Telemecanique™ Sensors is a trademark of Schneider Electric Industries SAS used under license by TMSS France. Any other brands or trademarks referred to in this catalogue are property of TMSS France or, as the case may be, of its subsidiaries or other affiliated companies. All other brands are trademarks of their respective owners. This catalogue and its content are protected under applicable copyright laws and provided for informative use only.

No part of this catalogue may be reproduced or transmitted in any form or by any means (electronic, mechanical, photocopying, recording, or otherwise), for any purpose, without the prior written permission of TMSS France. Copyright, intellectual, and all other proprietary rights in the content of this catalogue (including but not limited to audio, video, text, and photographs) rests with TMSS France, its subsidiaries, and other affiliated companies or its licensors. All rights in such content not expressly granted herein are reserved. No rights of any kind are licensed or assigned or shall otherwise pass to persons accessing this information.

As standards, specifications and design change from time to time, please ask for confirmation of the information given in this publication.

©2025, TMSS France, All Rights Reserved.

**TMSS France SAS**

Share capital: 366 931 214 €  
Tour Eqho, 2 avenue Gambetta  
92400 Courbevoie – France  
908 125 255 RCS Nanterre

June 2025 - V3.1

TESEBRC000040EN