



Valves and Actuators

NAM Catalog 2026



Life Is On

Schneider
Electric

About Schneider Electric

Schneider Electric is leading the Digital Transformation of Energy Management and Automation in Homes, Buildings, Data Centers, Infrastructure and Industries. With global presence in over 100 countries, Schneider is the undisputable leader in Power Management – Medium Voltage, Low Voltage and Secure Power, and in Automation Systems. We provide integrated efficiency solutions, combining energy, automation and software.

In our global Ecosystem, we collaborate with the largest Partner, Integrator and Developer Community on our Open Platform to deliver real-time control and operational efficiency.

We believe that great people and partners make Schneider a great company and that our commitment to Innovation, Diversity and Sustainability ensures that Life Is On everywhere, for everyone and at every moment.

www.se.com

Life Is On | **Schneider**
Electric

[Discover Life is On](#)

[Discover EcoStruxure](#)

The Schneider Electric brand and any trademarks of Schneider Electric SE and its subsidiaries referred to in this guide are the property of Schneider Electric SE or its subsidiaries. All other brands may be trademarks of their respective owners. This guide and its content are protected under applicable copyright laws and furnished for informational use only. No part of this guide may be reproduced or transmitted in any form or by any means (electronic, mechanical, photocopying, recording, or otherwise), for any purpose, without the prior written permission of Schneider Electric. Schneider Electric does not grant any right or license for commercial use of the guide or its content, except for a non-exclusive and personal license to consult it on an "as is" basis. Schneider Electric products and equipment should be installed, operated, serviced, and maintained only by qualified personnel. As standards, specifications, and designs change from time to time, information contained in this guide may be subject to change without notice. To the extent permitted by applicable law, no responsibility or liability is assumed by Schneider Electric and its subsidiaries for any errors or omissions in the informational content of this material or consequences arising out of or resulting from the use of the information contained herein.

About this Catalog and Online Resources

Welcome to the Schneider Electric Valves and Actuators Catalog

Superior engineering, product design patents, ISO9001 certification, and Six Sigma lean manufacturing ensures our products conform to the highest standards of internationally recognized quality to deliver solid performance, unsurpassed value and exceptional reliability.

Learn more at www.se.com/v-a

Note: Installers and technicians should stay updated on the “Recommendations/ Best practices and Hazard Warnings”. It is recommended to view this catalog in its electronic PDF version (Acrobat Reader required) for quick and easy access to assets, from software and firmware to technical documentation, as well as sales and marketing collateral.



mySchneider Sales Mobile App

Bring more “wow” to your customer meetings! mySchneider mobile app enables sales teams to share the latest marketing and sales content via their mobile device to make meetings and follow-up more productive.

With the mySchneider App you can:

- Easily access and view the latest assets (e.g., videos, presentations, specification sheets) while online
- Download assets for availability while offline
- Electronically mark up assets (highlight, pen) and save changes
- Manage a personal “channel” with your own presentation content
- Email assets to others (customers, consultants) and manage sharing activities/history
- Receive news and notifications on updates directly on your device
- To download mySchneider:
 - For iOS devices, mySchneider on the Apple App Store and search for “mySchneider”.
 - For Android devices, access the app in the Google Play store by searching for “mySchneider.” See the Play Store for Android system requirements.

You must self-register on mySchneider before using the mobile app. Register at: <https://idp.se.com/u/signup/>

About this Catalog and Online Resources

Online Valve & Actuator Product Selector

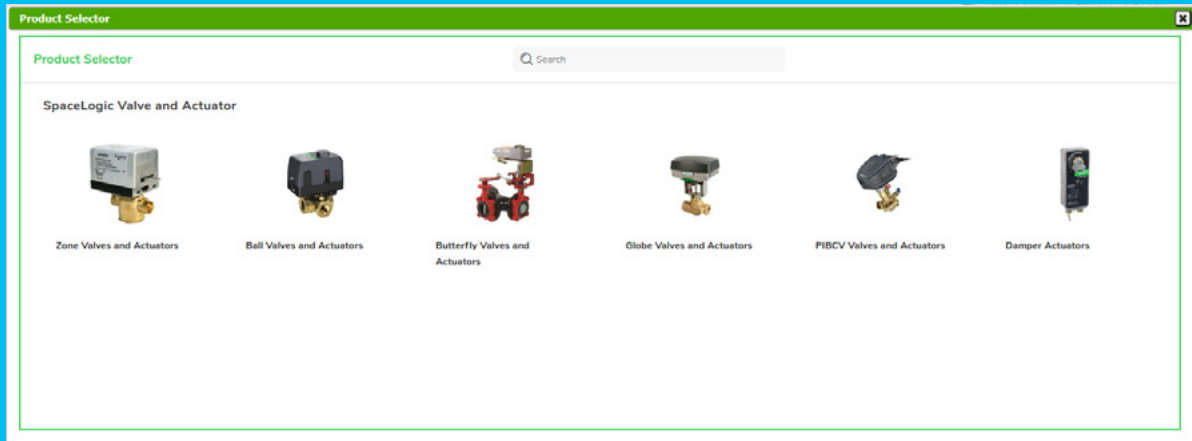

The Valve & Actuator Product Selector is a dynamic sizing tool designed to provide a quick and simple way to choose the most appropriate product for your application. A wealth of information is at your fingertips, including full technical details and quick access to key product documentation.

The Product Selector is accessible through iPortal at portal2.schneider-electric.com. Once you are logged into the site, navigate to the **Tools & Support** tab and select **Valve & Actuator Product Selector**.



Browser compatibility

- Chrome (preferred). Use of other browsers may exhibit unintended behaviors

Sizing and selection for all HVAC valves and actuators

- Ball Valves
- Butterfly Valves
- Globe Valves
- Pressure Independent Balancing Control Valves
- Zone Valves
- Shoe Valves
- Damper Actuators

Features

- Intuitive selection based on calculators and/or dropdown menus.
- Customer and partner profiles possible in any schedule creation.
- Valve and Actuator selection feature to create schedule of hydronic systems.
- Ability to create own or add to hydronics a schedule of damper actuators.
- Ability to view, edit, change, communicate and adjust schedules. Download completed schedules to Excel, PDF, and BOM.
- Ability to save schedules in progress to be worked on later or for use as a template for future projects.

Contents

6

Damper Actuators

23

Foot Mounted Actuators

33

Zone Valves and Actuators

44

Ball Valves and Actuators

66

Pressure Independent Balancing
Control Valves and Actuators

94

Globe Valves and Actuators

202

Butterfly Valves and Actuators

220

Guide Specification Text



Damper Actuators

Schneider Electric's comprehensive portfolio of damper actuators delivers on customer requirements including ease of installation, high performance, durability, precision, and energy efficiency.

SpaceLogic Damper Actuators give customers maximum efficiency AND high performance across a wide variety of HVAC applications. They deliver on performance with consistent, comfortable indoor climate maintenance ensuring occupant comfort and enhanced productivity.



Spring Return Direct Coupled SmartX Actuators

Value-driven general purpose applications

Mx4D-703x and Mx4D-803x Series

- Two position models controlled by SPST controller
- Floating models controlled by SPDT floating controllers
- Jumper selectable control function direct/reverse action
- Floating and proportional models automatically adjust input span to match the damper/valve travel



Damp and harsh environment applications

Mx40-717x Series

- Direct mount to round or square damper shaft
- 150 lb-in (17 N-m) torque rating, overload protection throughout rotation
- Oil immersed gear train provides continuous lubrication
- Automatic current sensing motor control provides extended reliability and repeatable timing
- Provides true mechanical clockwise or counterclockwise spring return operation for reliable positive close-off in airtight applications
- 5-year warranty, NEMA 4 housing (IEC IP56)
- Can be double mounted (gang mounting) to accommodate high torque application requirements to 4 actuators
- MS40-717x models provide position feedback signal



High performance HVAC applications

Mx40-704x Series

- Direct mount to round or square damper shaft
- 35 lb-in (4 N-m) torque rating
- Overload protection throughout rotation
- Optional built-in auxiliary switches
- True mechanical clockwise or counter clockwise spring return operation for reliable, positive close-off in airtight applications
- Visual position indicator
- Direct acting or reverse acting control mode available on proportional models
- Rotation limiting available
- Rugged die-cast housing for NEMA 2/IP54 rating



Mx41-7xx Series

- Direct mount to round or square damper shaft
- 60 lb-in (7 N-m) torque rating
- 133 lb-in (15 N-m) torque rating
- Overload protection throughout rotation
- Operational built-in auxiliary switches
- Provides true mechanical clockwise or counterclockwise spring return operation for reliable positive close-off in airtight applications
- Direct acting or reverse acting control mode available on proportional models
- Rotation limiting available
- Rugged die-cast housing for NEMA 2/IP54 rating
- Manual override



High torque HVAC applications

Mx41-730x Series

- 270 lb-in (30 N-m) of torque with mechanical spring return, manual override, and Brushless DC Motor.
- Stall protected throughout rotation and reversible mounting.
- Models for two position 24 Vac/Vdc, and two position 100 – 230 Vac applications
- Models for 2 – 10 Vdc input signal applications (field configurable for other input signals) with a position feedback signal and direct/reverse acting control mode selection switch on both side.
- Models for auxiliary switch applications.
- Models for NEMA 4 / IP66 outdoor applications.
- 95° of rotation, adjustable with mechanical end stops and graduated position indicator showing 0° to – 95°
- Can be double-mounted (gang mounting) to accommodate high torque application requirements



Damper Actuators

	Torque lb-in minimum	Control Type						2...10 VDC Feedback	0...10 VDC Feedback	Power				Power Input			Running Time (sec)		Auxiliary Switch	Spring Return Position				
		Two-Position	Floating	Proportional						24 VAC, 24 VDC	230, 240 VAC	120 VAC	100...240 VAC 100...125 VDC	VA @60 Hz	Watts @ 60 Hz		Powered	Spring Return						
				0...10 VDC	2...10 ^a VDC	4...20 mA	6...9 VDC								Running	Holding								
MA4D-7030	30												7.8	5.0	2.5	<56	<23		CCW					
MA4D-7033-100													5.1											
MA4D-8030													7.8	5.0	2.5						CW			
MA4D-8033-100													5.1											
MF4D-7033-100													6.8	4.2	1.9	85	21		CCW					
MF4D-8033-100																					CW			
MS4D-7033-100																								
MS4D-7033-150																								
MS4D-7033-160																								
MS4D-8033-100													6.1	3.4	1.4									
MS4D-8033-150																								
MS4D-8033-160																					CW			
MA40-7040	35												4.3	3.4	1.2	<80	<40	1	CW/ CCW					
MA40-7040-501																								
MA40-7041													4.6	3.9	1.2	<50	<28			1				
MA40-7041-501																								
MA40-7043													4.4	2.9	0.8						1			
MA40-7043-501																								
MF40-7043													5.9	4.4	2.9	<130	<25			1				
MF40-7043-501																								
MS40-7043													5.6	4.2	2.4						1			
MS40-7043-501																								
MS40-7043-MP													6.6	5.0	3.2						1			
MS40-7043-MP5																								
MA41-7070	60												5.6	3.6	1.2			<80		<40	2			
MA41-7070-502																								
MA41-7071													8.0	4.0	1.4	<80	<40			2				
MA41-7071-502																								
MA41-7073													4.8	3.2	0.8						2			
MA41-7073-502																								
MF41-7073													6.2	4.8	2.8	<195				2				
MF41-7073-502																								
MS41-7073													5.8	4.6	2.3						2			
MS41-7073-502																								
MA41-7150		133												10.0	8.4			3.3		<30			2	
MA41-7150-502																								
MA41-7151													10.6	8.5	5.0							2		
MA41-7151-502																								
MA41-7153													9.7	7.5	2.8	<190			2					
MA41-7153-502														7.7	3.2								2	
MF41-7153																								
MF41-7153-502																								
MS41-7153														7.4	2.9			2						
MS41-7153-502																								
MA40-7170	150													8.4			<162	<82						
MS40-7170														8.5			<147	<65						
MS40-7171													10.8											
MA40-7173													7.4			<162	<82							
MF40-7173													8.1			<162	<82							
MS40-7173													7.8			<147	<65							
MA41-7303	270												16 ¹	9.5	4.5	75	<20		2					
MA41-7303-502																								
MA41-7300													21										2	
MA41-7300-502																								
MS41-7303 ³													16 ¹						2					
MS41-7303-502 ³																								
MS41-7303-WH2 ³												16 21 w/ heater ¹	9.5 21 w/ heater		150 ⁴			2						

a - Proportional models with a 2...10 VDC control signal accept a 4...20 mA signal with the use of a 500 ohm resistor.
 1 - Class 2 power source.
 3 - Also compatible with floating, pulse width modulating (PWM), and other DC signal inputs with use of the BEL-ZTH US Handheld Interface Module for Field Programming.
 4 - Timing field adjustable from 60...150 seconds with use of the BEL-ZTH US Handheld Interface Module for Field Programming.

Mx4D-703x and Mx4D-803x Series 30 lb-in SmartX Direct Coupled Damper Actuators

Product description

Designed for controlling air dampers in building systems that require fail safe return, with two position, floating or proportional control.

Features

- Two position models controlled by SPST controller
- Floating models controlled by SPDT floating controllers
- Jumper selectable control function direct/reverse action
- Spring return models provide 30 in-lb (3.4 N-m) of torque
- Polymer housing rated for NEMA 2/IP54
- Overload protection throughout stroke
- Floating and proportional models automatically adjust input span to match the damper/valve travel
- Compact size allows installation in limited space
- Manual override allows positioning of dampers and valves
- Directly mounts to 1/2 – 3” Schneider Electric ball valves.

Specifications	
Control signal	Refer to the tables for actuator models and control types
Power inputs	See table.
Connections	3 ft (91 cm) appliance (see * in table below) or 10 ft. (3m) plenum cables enclosure accepts 1/2” (13mm) conduit connector.
Electrical outputs	Position Feedback voltage (proportional or floating only): For voltage rangers, the feedback signal is the same range as the input signal. The 4–20 mA current range and floating actuators have a 2–10 Vdc feedback signal. The feedback signal can supply up to 0.5 mA to operate up to four additional slave actuators.
Mechanical outputs	Travel: 95° nominal. Manual override: allows positioning of damper or valve using manual crank. RA/DA Jumper: Permits reverse acting/direct acting control (MS4D models only/)
Ambient temperature limits	Shipping and storage: -40–160°F (-40–71°C) Operating: -22–140°F(-30–60°C) Humidity: 15–95% RH, non-condensing
Location	NEMA 1. NEMA 2. UL Type 2 (IEC IP54) with customer supplied water tight conduit connectors. Enclosure is air plenum rated.
Agency listings	UL 873: Underwriters Laboratories (File #E9429 Category Temperature-Indicating and Regulating Equipment. Cul: UL LISTED for use in Canada by Underwriters Laboratories. Canadian standards C22.2 No. 24-93. This product fits in Installation Category (Overvoltage Category) II Per EN 61010-1.



Part Number	Torque Nm	Spring Return	Actuator Inputs			Outputs		Approximate Timing in seconds @ 70°F			
			Control	Voltage	VA @ 60Hz	Feedback	Auxiliary Switch	Powered	Spring Return		
MA4D-7033-100	30 (3.4)	CCW	2 position	24 Vac/dc	5.1	-	No	56	23		
MA4D-7030				120 Vac	7.8						
MA4D-8033-100				24 Vac/dc	5.1						
MA4D-8030				120 Vac	7.8						
MF4D-7033-100		CCW	Floating	24 Vac/dc	6.8	2–10 vdc	No	85	21		
MF4D-8033-100										CW	2–10 vdc
MS4D-7033-100		CCW	2 position	24 Vac/dc	6.1	2–10 vdc	No	85	21		
MS4D-7033-150										0–10 vdc	0–10 vdc
MS4D7033-160										4–20 ma	2–10 vdc
MS4D-8033-100										2–10 vdc	2–10 vdc
MS4D-8033-150		CW	2 position	24 Vac/dc	6.1	2–10 vdc	No	85	21		
MS4D-8033-160										0–10 vdc	0–10 vdc
MS4D-8033-100		CW	2 position	24 Vac/dc	6.1	2–10 vdc	No	85	21		
MS4D-8033-150										0–10 vdc	0–10 vdc
MS4D-8033-160	CW	2 position	24 Vac/dc	6.1	2–10 vdc	No	85	21			
MS4D-8033-100									4–20 ma	2–10 vdc	

Mx40-704x Series 35 lb-in SmartX Direct Coupled Damper Actuators

Product description

For spring return applications requiring floating, two-position, or proportional modulation control of dampers and valves in HVAC systems. Directly mounts to 1/2"–3" Schneider ball valves.

Features

- Direct mount to round or square damper shaft
- Overload protection throughout rotation
- Optional built-in auxiliary switches
- True mechanical clockwise or counter clockwise spring return operation for reliable, positive close-off in airtight applications
- Visual position indicator
- Direct acting or reverse acting control mode available on proportional models
- Rotation limiting available
- Rugged die-cast housing for NEMA 2/IP54

Specifications	
Control signal	On-off, SPST control contacts or Triacs (500 mA rated). Floating point control, 24 Vac. Proportional, 6...9, 2...10 Vdc or 4 to 20 mA dc with a 500 Ω resistor.
Power inputs	See table.
Connections	MA40-704x and MA40-704x-501 – 3ft. (91 cm) long , appliance cables, 1/2" conduit connector. For M20 Metric conduit, use AM-756 adaptor; MF40-7043 and MF40-7043-501 – 3ft. (91 cm) long, plenum-related cables, 1/2" conduit connector. For M20 Metric conduit, use AM-756 adaptor.
Electrical outputs	Position Feedback voltage "AO" 2–10 Vdc (maximum 0.5mA) output signal for position feedback or operation of up to four slave actuators. One auxiliary switch (select models). SPDT 6a resistive @ 24 Vac or 250 Vac.
Mechanical outputs	Travel rotation is limited to 95° ± maximum, adjustable from 40–95° with a mechanical stop. RA/DA switch: selects direct acting or reverse acting for proportional models. Position Indicator: Visual indicator 0–1 (0 is the spring return position).
Ambient temperature limits	Shipping and storage: -40–160°F (-40–71°C) Operating: -22–140°F (-30–60°C) Humidity: 5–95% RH, non-condensing
Location	NEMA 2 IEC IP54
Agency listings	UL 873: Underwriters Laboratories (File #E9429 Category Temperature-Indicating and Regulating Equipment). CUL: UL LISTED for use in Canada by Underwriters Laboratories. Canadian standards C22.2 No. 24.



Part Number	Torque Nm	Spring Return	Actuator Inputs			Outputs		Approximate Timing in seconds @ 70°F			
			Control	Voltage	VA @ 60Hz	Feedback	Auxiliary Switch	Powered	Spring Return		
MA40-7040	30 (4)	CW/CCW	2 position	120 Vac	4.3	-	-	<50	<28		
MA40-7040-501					4.6		1-SPDT (250)Vac				
MA40-7041				24 Vac/dc	4.4		-				
MA40-7043					4.4		1-SPDT (24)Vac				
MA40-7043-501					5.9		-			<130	<25
MF40-7043							1-SPDT (24)Vac				
MF40-7043-501			2–10 vdc	5.9	2–10 vdc	-					
MS40-7043						1-SPDT (24)Vac					
MS40-7043-501						-					
MS40-7043-MP ^a			6.6	6.6	6.6	-					
MS40-7043-MP5 ^a						1-SPDT (24)Vac					

a - For MP and MP5; Provides auxiliary power supply +20 Vdc 25 mA maximum.

Damper Actuators

Mx41-7xxx Series 60 lb-in and 133 lb-in SmartX Direct Coupled Damper Actuators

Product description

Designed for controlling air dampers in building systems that require fail safe return, with two position, floating or proportional control.

Features

- Direct mount to round or square damper shaft
- Overload protection throughout rotation
- Optional built-in auxiliary switches
- Provides true mechanical clockwise or counterclockwise spring return operation for reliable positive close-off in airtight applications.
- Direct acting or reverse acting control mode available on proportional models
- Rotation limiting available
- Rugged die-cast housing for NEMA 2/IP54
- 5-year warranty

Specifications

Control signal	On-off, SPST control contacts or Triacs (500 mA rated). Floating point control, 24 Vac. Proportional, 2...10 Vdc or 4 to 20 mA dc with a 500 Ω resistor
Power inputs	See table.
Connections	3 ft. appliance cables, 1/2 in. conduit connector
Electrical outputs	Position Feedback voltage "AO" 2–10 Vdc (maximum 0.5mA) output signal for position feedback or operation of up to four slave actuators. Two auxiliary switches available (select models). SPDT 7a resistive @ 24 Vac or 250 Vac.
Mechanical outputs	Travel rotation is limited to 95° ± 5 maximum, adjustable from 30–95° with a mechanical stop. Position indicator: Pointer and scale are provided. Manual Override: manual adjustable rotation -5–85°
Ambient temperature limits	Shipping and storage: -40–160°F (-40–71°C) Operating: -22–140°F(-30–60°C) Humidity: 5–95% RH, non-condensing
Location	NEMA 1, NEMA 2 (IEC IP54) with conduit connector in down pos.
Agency listings	UL 873: Underwriters Laboratories (File #E9429 Category Temperature-Indicating and Regulating Equipment). CUL: UL LISTED for use in Canada by Underwriters Laboratories. Canadian standards C22.2 No. 24.



Part Number	Torque Nm	Spring Return	Actuator Inputs			Outputs		Approximate Timing in seconds @ 70°F	
			Control	Voltage	VA @ 60Hz	Feedback	Auxiliary Switch	Powered	Spring Return
MA41-7070	60 (7)	CW/CCW	2 position	120 Vac	5.6	-	-	<80	<40
MA41-7070-502					2-SPDT (250)Vac				
MA41-7071					8.0		-		
MA41-7071-502					2-SPDT (250)Vac				
MA41-7073					4.8		-		
MA41-7073-502	2-SPDT (24)Vac								
MA41-7150	133 (15)		2 position	120 Vac	10.0	-	-	<190	<30
MA41-7150-502					2-SPDT (250)Vac				
MA41-7151					10.6		-		
MA41-7151-502					2-SPDT (250)Vac				
MA41-7153		9.7			-				
MA41-7153-502	2-SPDT (24)Vac								
MF41-7073	60 (7)	Floating	24 Vac/dc	6.2	-	-	<195	<30	
MF41-7073-502	2-SPDT (24)Vac								
MF41-7153	133 (15)			9.7		-			
MF41-7153-502	2-SPDT (24)Vac								
MS41-7073	60 (7)			5.8		-			
MS41-7073-502	2-SPDT (24)Vac								
MS41-7153	133 (15)	2–10 vdc	24 Vac/dc	9.7	2–10 vdc	-	<190	<30	
MS41-7153-502				2-SPDT (24)Vac					

Mx40-717x Series 150 lb-in SmartX Direct Coupled Damper Actuators

Product description

Designed for controlling air dampers in building systems that require fail safe return, with two position, floating or proportional control.

Features

- Direct mount to round or square damper shaft
- Overload protection throughout rotation
- Oil immersed gear train provides continuous lubrication
- Automatic current sensing motor control provides extended reliability and repeatable timing
- Provides true mechanical clockwise or counterclockwise spring return operation for reliable positive close-off in airtight applications
- Can be double-mounted (gang mounting) to accommodate high torque application requirements (2 to 4 actuators)
- MS40-717x models produce position feedback signal
- Linkage required for Globe Valve Assembly.



Specifications	
Control signal	Two wire, SPST or Triacs (500 mA rated) SPDT floating control output, Triacs (500 mA rated), or 2 SPST contacts. Proportional 2 to 10 Vdc or 4 to 20 mA dc with a 500 Ω(not included).
Power inputs	See table.
Connections	Class 1: 24 inch (61 cm) long appliance cables, 18 AWG color coded leads. 1/2 in. conduit connector. Class 2: Power and control: 36 inch (91 cm) Long, 22 AWG color coded appliance cable pigtail leads. 1/2 in. conduit connector.
Electrical outputs	Travel: Electronically limited to 92° ±1 ° (MS), MF-MA Mechanically limited to 101° ±1 °
Mechanical outputs	Position indicator: pointer and scale are provided
Ambient temperature limits	Shipping and storage: -40–160°F (-40–71°C) Operating: -22–140°F(-30–60°C) Humidity: 5–95% RH, non-condensing
Location	NEMA 1,NEMA 2 (IEC IP54) with customer supplied water tight conduit connectors.
Agency listings	UL 873: Underwriters Laboratories (File #E9429 Category Temperature-Indicating and Regulating Equipment). Cul: UL LISTED for use in Canada by Underwriters Laboratories. Canadian standards C22.2 No. 24–93.

Part Number	Torque Nm	Spring Return	Actuator Inputs			Outputs		Approximate Timing in seconds @ 70°F	
			Control	Voltage	VA @ 60Hz	Feedback	Auxiliary Switch	Powered	Spring Return
MA40-7170	150(17)	CW/CCW	2-position	120 Vac	8.4	-	No	162	82
MA40-7173				24 Vac/ dc	7.4				
MF40-7173			Floating	8.1	2–10 vdc	147	65		
MS40-7170			120 Vac	8.5					
MS40-7171			240 Vac	10.8					
MS40-7173			24 Vac/dc	7.8					

Mx41-730x Series 270 lb-in SR SmartX Damper Actuators

Mx41-730x Series Spring Return SmartX Actuators are available with Two Position 24 Vac/Vdc, Two Position 100...230 Vac, and 2...10 Vdc input signal applications. It is possible to field configure the 2...10 Vdc input signal models for other input signals such as floating and pulse width modulating (PWM).

Features

- Mechanical spring return, manual override and brushless DC Motor
- Stall protected throughout rotation and reversible mounting
- Models for auxiliary switch applications
- Direct mount to 1/2"–3/4" round or 1/2"–11/16" square damper shafts of to 3/4"–1.05" round with the field removal of a clamp insert
- 95° of rotation, adjustable with mechanical end stops and graduated position indicator showing 0°–95°
- Can be double-mounted (gang mounting) to accommodate high torque application requirements
- 5-year warranty.

Specifications	
Control signal	Two position, 2–10 Vdc ^a
Optional control signal (MS41 models only)	Floating, Pulse width modulating (PWM), Adjustable start point and Span DC signal inputs with use of the BEL-ZTH US handheld interface module for field programming
Power inputs	See table.
Connections	3' appliance cable with 18 Ga. (0.9 mm) conductors and one 1/2" conduit connector -WQ2/-WH2 models: Removable terminal blocks.
Electrical outputs	Position feedback: 2–10 Vdc, 0.5 mA max, adjustable with optional BEL-ZTH US Handheld Interface Module for Field Programming. Auxiliary Switch: 2SPDT 3A (0.5 A) @ 250 Vac (see table)
Mechanical outputs	Travel: Angle of rotation 95° max. Position indicator: graduated position indicator showing 0°–95° Manual override: Actuators provided with 5 mm hex crank
Ambient temperature limits	Shipping and storage: -40–176°F (-40–80°C) Operating: -22–122°F (-30–50°C) Humidity: 5–95% RH, non-condensing
Location	NEMA 2 and NEMA 4 (select models; see table)
Agency listings	c-UL-us LISTED per UL 60730-1A & -2-14, and CAN/CSA E60730-1:02, CE compliant to directives 2014/35/EU [LVD], 2014/30/EU EMC], and 2011/65/EU [RoHS2].



a - Also compatible with two position, floating, PWM, and proportional input signals, refer to the SmartX Actuators Spring Return Damper Mx 730x Series Installation Instructions, F27870.

Part Number	Torque Nm	Spring Return	Actuator Inputs			Outputs		Approximate Timing in seconds @ 70°F			
			Control	Voltage	VA @ 60Hz	Feedback	Auxiliary Switch	Powered	Spring Return	NEMA 4	Heater
MA41-7303	270 (30)	CW/CCW	Two position	24 Vac	16 VA	-	-	75	<20	-	-
MA41-7303-502				100–240 Vac	21 VA at 100 Vac, 29 VA at 240 Vac		-				
MA41-7300					2						
MA41-7300-502			2–10 vdc	24 Vac	16 VA	10.8 7.8	2	150	Yes	Yes	
MS41-7303											
MS41-7303-502											
MS41-7303-WH2											

Overview - NSR SmartX Damper Actuators

High performance HVAC applications

Mx41-60xx Series

- 44 lb-in (5 N-m) and 88 lb-in (10 N-m) torque
- Compact lightweight design
- Easy-to-see position indicator
- Self-adapting capability for maximum flexibility in damper positioning
- Quiet, low-power operation
- Manual override
- Plenum cable standard
- Independently adjustable dual auxiliary switches option available (Mx41-6083-502)
- Feedback position output signal available (MS41-6043/6083 series)
- c-UL-us LISTED and CE marked.



Mx41-6153 Series

- Synchronous motor technology with stall protection
- Unique self-centering shaft coupling
- Manual override
- 133 lb-in (15 N-m) torque
- 5 preload as shipped from factory
- Mechanical range adjustment capabilities
- Independently adjustable dual auxiliary switches option available (MS41-6153-502)
- Built-in 1/2" conduit connection
- c-UL-us LISTED and CE marked.



Damp and Harsh Environment Applications

Mx41-63xx Series

- 300 lb-in (34 N-m) torque
- NEMA Type 4 housing (IEC IP56)
- Custom automatic current sensing motor control provides extended reliability and repeatable timing
- Direct coupled to damper shaft with dual industrial hardened universal mounting clamps
- Integral wiring for proportional control by 2–10 Vdc or 4–20 mA dc
- Clockwise or counterclockwise rotation is determined by actuator mounting position
- Manual override for ease of installation and manual operation of damper
- Accurate 92° travel digitally controlled
- Integral position indication scale
- Rugged die-cast housing
- Oil immersed gear train provides continuous lubrication
- Rated for operating temperatures up to 140°F (60°C)
- 5 year warranty
- MS41-634x SmartX Actuators can be double mounted (gang mounting) to accommodate high torque application requirements (2 to 4 actuators)
- Position feedback signal
- c-UL-us LISTED and CE marked



	Min	Max Stall	Floating	Proportional			0...10 VDC	2...10 VDC	24 VAC, 24 VDC	24 VAC	120 VAC	VA @60Hz	Watts @60Hz	Watts @60Hz	Watts @60Hz	Powered	SPDT, 6A, Resistive, 24 VAC	SPDT, 4A Resistive, 24 VAC
				0...10 VDC	2...10 VDC*	4...20 mA												
MF41-6043	44											2.3			90			
MS41-6043												3.3			90			
MF41-6083													2.3					
MF41-6083-502	88																2	
MS41-6083													3.3					
MS41-6083-502																125		2
MF41-6153	133																	
MS41-6153													3					
MS41-6153-502														5	4	1		2
MF41-6343	300	650																
MS41-6343														5.7	3.9	2.8	<162	
MS41-6340															5.6	3.6	2.4	
MS41-6340														7.5	4.7	3.0	<145	

a - Proportional models with a 2...10 VDC control signal accept a 4...20 mA signal with the use of a 500 ohm resistor.

Damper Actuators

Mx41-60x3 Series 44 and 88 lb-in NSR SmartX Direct Coupled Damper Actuators

These direct coupled 24 Vac non-spring return rotary electric SmartX Actuators are designed for three position (floating) control of the dampers

Features

- Compact, lightweight design
- Easy-to-see position indicator
- Self-adapting capability for maximum flexibility in damper positioning
- Quiet, low-power operation
- Plenum cable standard
- Independently adjustable dual auxiliary switches option available (Mx41-6083-502)
- Feedback position output signal available (MS41-6043/6083 series).

Specifications

Control signal	MF41-60x3 – Floating three-position control, 24 Vac. MS41-60x3 – Proportional, 0 to 10 Vdc; input resistance 100 kW
Power inputs	See table
Connections	3' (0.9 m) appliance cable, 18 AWG plenum-related leads
Electrical outputs	Position feedback for MS41-6043/6083: 0–10 Vdc, 1mA. Auxiliary switches: dual auxiliary switches available with MF41-6083-502, MS41-6083-502 when these actuators are ordered as separate units. Auxiliary switches are not offered with factory ball valve assemblies
Mechanical outputs	Travel: Normal angle of rotation is 90° limited to a maximum of 95° Field adjustable to limit travel on either end of stroke
Ambient temperature limits	Shipping and storage: -40–158°F (-40–70°C) Operating: -25–130°F (-32–55°C) NOTE: Check the valve operating temperature limit. The minimum valve temperature limit is 20°F (6.7°C) 5–95% non-condensing.
Location	NEMA Type 2 (IEC IP54)
Agency listings	c-UL-us LISTED per UL 873 and CAN C22.2 No.24-93. CE compliant to directive LVD, EMC, RoHS2



Part Number	Torque Nm	Actuator Inputs			Outputs		Approximate Timing in seconds @ 70°F
		Control	Voltage	VA @ 60Hz	Feed- back	Auxiliary Switch	
MF41-6043	44(5)	Float- ing	24 Vac	2.3	–	–	90
MF41-6083	88(10)						125
MF41-6083-502							2-SPDT
MS41-6043	44(5)	0–10 Vdc	24 Vac	3.3	0–10 Vdc	–	90
MS41-6083	88(10)						125
MS41-6083-502							2-SPDT

Mx41-6153 Series 133 lb-in NSR SmartX Direct Coupled Damper Actuators

The direct coupled 24 Vac non-spring return electric SmartX actuator is designed for modulating and three-position control of building HVAC dampers requiring up to 133 lb-in (15 Nm) torque.

Features

- Synchronous motor technology with stall protection
- Unique self-centering shaft coupling
- 5° preload as shipped from factory
- Mechanical range adjustment capabilities
- Independently adjustable dual auxiliary switches option available (MS41-6043-502)
- Built-in 1/2" conduit connection.

Specifications

Control signal	MF41-6153 – floating three position control, 24 Vac. MS41-6153, MS41-6153-502 – Proportional, 0 to 10 Vdc; input resistance 100 kW
Power inputs	See table
Connections	3' (0.9 m) long, 18 AWG leads
Electrical outputs	Position output signal (wires 9-2) MS41-6153 Series Voltage-output 0–10 Vdc. Maximum output current 1 ± mA
Mechanical outputs	Nominal angle of rotation is 90° Maximum angular rotation 95°
Ambient temperature limits	Shipping and storage: -40–158°F (-40–70°C) Operating: -25–130°F (-32–55°C) Humidity: 95% non-condensing
Location	NEMA1/IP54 according to EN 60 529
Agency listings	c-UL-us LISTED per UL 873 and CAN C22.2 No.24-93. CE compliant to directives LVD, EMC, RoHS2



Part Number	Torque Nm	Actuator Inputs			Outputs		Approximate Timing in seconds @ 70°F
		Control	Voltage	VA @ 60Hz	Feedback	Auxiliary Switch	
MF41-6153	133 (15)	Floating	24Vac	3	–	–	125
MS41-6153		0–10 Vdc		5	0–10 Vdc	2-SPDT	
MS41-6153-502							

Mx41-634x Series 300 lb-in NSR SmartX Direct Coupled Damper Actuators

Direct Coupled SmartX actuators are designed to be used in both damper and valve control applications. The MS41-634x series actuators are over the shaft non-spring return actuators compatible with 0–10 Vdc or 4–20 mA dc¹ control signals.

Features

- Custom automatic current sensing motor control provides extended reliability and repeatable timing
- Direct coupled to the damper shaft with dual industrial hardened universal mounting clamps
- Clockwise or counterclockwise rotation is determined by actuator mounting position
- Accurate 92° travel digitally controlled
- Integral position indication scale
- Oil immersed gear train provides continuous lubrication
- Rated for operating temperatures up to 140 F (60 C)
- 5 year warranty
- MS41-634x SmartX Actuators can be double-mounted (gang mounting) to accommodate high torque application requirements (2 to 4 actuators)
- Position feedback signal.

Specifications

Control signal	SPDT floating control input; Triacs (500 mA rated) or 2 SPST contacts Floating: 24 Vac ± 20% Proportional: 2–10 Vdc 4-20 mAdc ^a
Power inputs	See table
Connections	3' (91 cm) Appliance cable, 1/2" conduit connectors
Electrical outputs	Travel: Mechanically limited to 101° ±1°
Mechanical outputs	Overload Protection: Throughout rotation. Nominal angle of rotation is 93° Position Indication: Scale numbered 0–95° Manual override: allows manual positioning
Ambient temperature limits	Shipping and storage: -40–160°F (-40–71°C) Operating: -25–140°F (-32–60°C) Humidity: 5–95% non-condensing
Location	NEMA Type 1. NEMA Type 4 (IEC IP56) with customer supplied water tight conduit connectors
Agency listings	c-UL-us LISTED per UL 873 and CAN C22.2 No.24-93. CE compliant to directives LVD, EMC, RoHS2

a - With the addition of a 500 ohm resistor (AM-708).



Part Number	Torque Nm	Actuator Inputs			Outputs		Approximate Timing in seconds @ 70°F Powered
		Control	Voltage	VA @ 60Hz	Feedback	Auxiliary Switch	
MF41-6343	300 (34)	Floating	24 Vac/ dc	5.7	–	No	162
MS41-6343		2–10 Vdc		5.6			2–10 Vdc
MS41-6340			120 Vac	7.5			

MU41-x063 Series Fail-Safe/Fail-in-Place, 53 lb-in (6 Nm) Rotary, Electronic Damper Actuators

The SmartX direct-coupled fail-safe/fail-in-place electronic actuators are designed for modulating, two-position, and floating control of laboratory fume hoods, constant or variable volume installations for the control of supply/exhaust air and terminal units.

Features

- Fast operation, 2 second runtime
- One model performing all control signals
 - 2-position control
 - Floating control
 - Modulating control (0(2)...10 Vdc; 4...20 mA)
- Feedback is standard on all models
- Highly accurate positioning
 - Repositioning resolution 0.4%
- Brushless DC motor technology with stall protection.
- Unique self-centering shaft coupling
- 53 lb-in 6 (Nm) torque
- UL and cUL listed, CE certified
- 24 Vac/dc compatible
- Plenum Rated.

Running torque	53 lb-in (6 Nm)	
Maximum torque	142 lb-in (16 Nm)	
Runtime for 90°	2 sec. operating	
Frequency	50/60 Hz	
Run time for 90°	2 sec Fail safe on power loss (MU41-7063 only)	
Power consumption	24 Vac/dc	
	MU41-7063	MU41-6063
Running	28 VA / 19W	28 VA / 19W
Holding	8 VA / 5W	8 VA / 5W
Equipment rating (24 Vac)	Class 2 per UL/CSA	
Angle of rotation	90° nominal, 95° max.	
Shaft dimensions	¼... ¾" (6.4...20.5 mm) dia. ¼...½" (6.4 to 13 mm) sq.	
Minimum shaft length	¾" (20 mm)	
Operating temperature	0...122 °F (-18...50 °C)	
Storage temperature	-40...158 °F (-40...70 °C)	
Transport temperature	-26...158 °F (-32...70 °C)	
Ambient humidity	95% rh (non-condensing)	
Enclosure	NEMA 1	
Precabled connection	18 AWG, 3' (0.9 m) long	
Agency listings		
UL listed	UL 873	
cUL listed	C22.2 No. 24.93	
NOTE: These devices are approved for installation in plenum areas by Underwriters Laboratories, Inc. (UL) per UL 1995.		
Electromagnetic compatibility (EMC)	2004/108/EC	
Material	Die-cast aluminum alloy	
Gear lubrication	Silicone-free	
Dimensions	8-3/8" H × 3¼" W × 2-3/8" D (212 mm H × 83 mm W × 60 mm D)	
Shipping weight	3 lbs 6 oz	

Part Number	Fail-Safe	Fail-in-Place
MU41-7043	●	
MU41-6043		●



0453X Series Two-position Damper Actuators

The 0453L, light duty Damper Actuators are designed for a variety of Two-position, spring return, damper applications. The 0453L uses a two-wire thermostat control.

The 0453H medium duty Damper Actuators are designed for a variety of Two-position, spring return damper applications. The 0453H uses a two-wire thermostat control.

The 0453R heavy duty Damper Actuators are designed for a variety of Two-position, motor open and motor closed damper applications. The 0453R uses a three-wire thermostat control.

Features

- Available with end switch
- Linkage or direct drive available
- Hysteresis synchronous motor with “lost motion” drive to protect gear train from closing shock

Specifications

Inputs	
Voltage	24 Vac @ 50/60 Hz, 110/120 Vac @ 50/60 Hz, 220/230 Vac @ 50/60 Hz
Power	See Model table
Connections	Internal junction box, 18" leads, cord sets
Outputs	
Mechanical	Optional End Switch ;10 A @ 120 Vac
Direction of rotation	CW or CCW rotation is available
Linkage	Customer supplied
Direct drive	For 5/16" maximum damper output shaft with maximum engagement of 7/8".
Environment temperature limits:	
Shipping and storage	-40 to 169°F (-40 to 71°C)
Operating Humidity	0 to 120°F (-17 to 49°C) Non-condensing.
Shipping weight	0453L & 0453H: 1.2 lbs (544 g); 0453R: 1.7 lbs (771 g).
Location	NEMA 1
Regulatory compliance (All are rated for use in Plenum spaces).	c-UR-us RECOGNIZED Components, safety evaluated per UL 60730-1 & -2-14, (including US FCC Part-15 Class-B emissions) and safety evaluated per CSA/CAN E60730-1 & -2-14, (including ICES-003 Class-B emissions)
Models 0453L, 0453H	
Models 453L, 453H, 453R:	CE Mark compliant, safety evaluated per EN 60730-1 & -2-14, (including EN 61000-6-2 EU immunity & EN 61000-6-3 EU emissions)
Optional accessories	
453-52	6 to 12" damper shaft kit
453-69	12 to 20" damper shaft kit

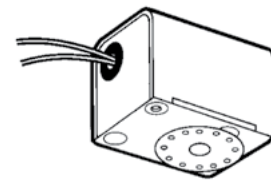

Linkage Drive

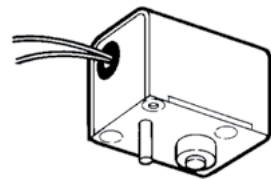

Direct Drive

Model Table

Model Number	Torque rating in.-oz.				Power		Stroke speed in seconds	
	Motor Driven		Spring Return				Motor Driven	Spring Return
	0°	84°	0°	84°	W	VA		
0453L	45	25	17	25	6.5	7	18 @ 60 Hz 22 @ 50 Hz	6 @ 50/60 Hz
0453H	55	35	35	55	6.5	10	27 @ 60 Hz 32 @ 50 Hz	8 @ 50/60 Hz
0453R	150	150	-	-	6.5	7	37 @ 60 Hz 45 @ 50 Hz	-

Damper Accessories

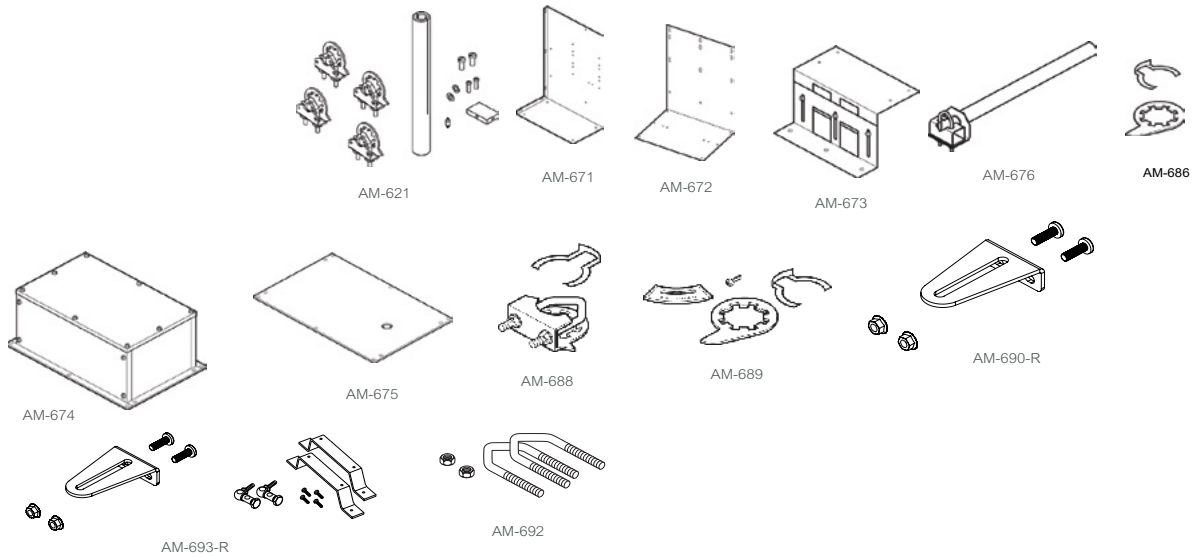

Part Number	Description	Spring Return Actuators								Non Spring Return Actuators							
		MA40-7043 MF40-7043	MS40-7043	MA41-7073 MF41-7073	MS41-7073	MA41-7153 MF41-7153	MS41-7153	MA40-717x MF40-7173	MS40-7173	MS4D-x033	MF41-6043 MS41-6043	MF41-6083	MS41-6083	MF41-6153	MS41-6153	MF41-6343	MS41-6343
AM-621	Round Shaft Extension																
AM-671 ^{abcd} AM-672 ^{abcd} AM-673 ^c	Mounting Bracket																
AM-674	Weather Shield & Base																
AM-675																	
AM-676	Shaft Extension																
AM-686	Position Indicator																
AM-687 ^e	V-clamp																
AM-688	Replacement Universal Clamp																
AM-689	Rotation Limiter																
AM-690-R ⁱ	Crank Arm																
AM-692 ^f	V-bolt																
AM-693-R ^h	Crank Arm Kit																

a - AM-693 crank arm kit required.
 b - Cannot be used with Mx41-634x or Mx40-717x series actuators.
 c - Drill appropriate mounting holes where needed.
 d - The large "C"-shaped clamps included in AM-693 crank arm kit are required for mounting the actuator. Drill appropriate mounting holes where needed.
 e - For shafts to 1.05" diameter or 5/8" square.
 f - For shafts to 3/4" and 1.05" diameter (with AM-690 and AM-691, respectively).

g - Use the self-tapping screws and flat washers provided in kit to mount actuator.
 h - AM-692 V-bolt kit required. The AM-693-R damper linkage kit is used in conjunction with the AM-687 or AM-688 universal clamps to provide a mechanical linkage between the damper actuator and the damper shaft when a direct coupling is not possible.
 i - Used in conjunction with the AM-687 or AM-688 universal clamps for crankarm functionality in non-direct mounting applications.

Damper Accessories

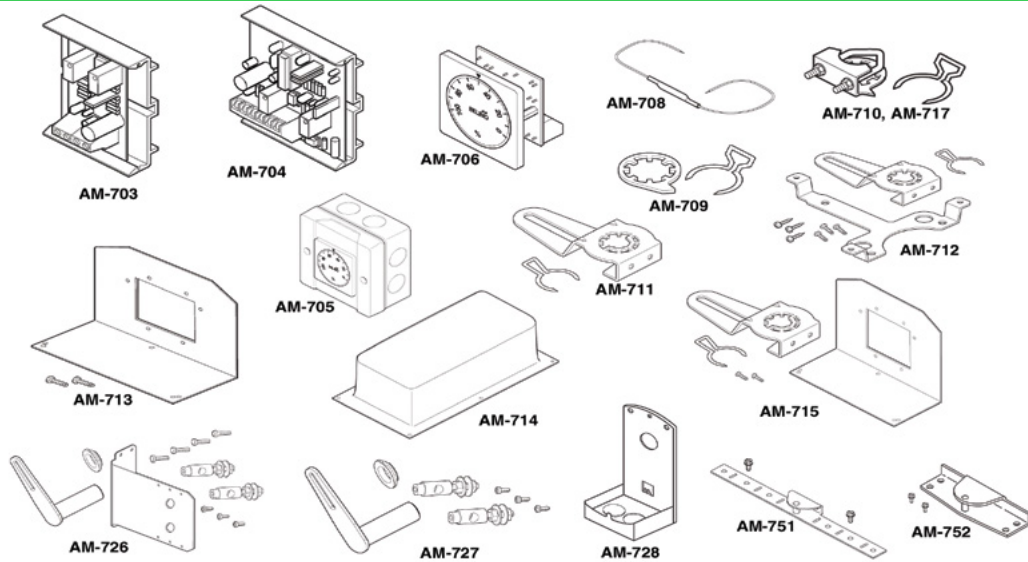

Part Number	Description	Spring Return Actuators								Non Spring Return Actuators									
		MA40-7043 MF40-7043	MS40-7043	MA41-7073 MF41-7073	MS41-7073	MA41-7153 MF41-7153	MS41-7153	MA40-717x MF40-7173	MS40-7173	MS4D-x033	MF41-6043	MS41-6043	MF41-6083	MS41-6083	MF41-6153	MS41-6153	MF41-6343	MS41-6343	Mx41-730x
AM-703	Span Adjustment																		
AM-705	Positioner																		
AM-706																			
AM-708	500 Ω Resistor																		
AM-709	Position Indicator & Stroke Limiter																		
AM-710 ^a	V-clamp																		
AM-711	Crank Arm Adaptor Kit																		
AM-712																			
AM-713	Bracket																		
AM-714	Weather Shield																		
AM-715	Crank Arm Adaptor Kit																		
AM-717	Replacement Universal Clamp																		
AM-726	Crank Arm Adaptor																		
AM-727																			
AM-728 ^b	Conduit Adaptor																		
AM-751	Anti-rotation Bracket																		
AM-801	Mx41-730x-xxx Actuator Crank Arm Kit																		
AM-802	Mx41-730x-xxx Actuator Crank Arm Kit with Actuator Mounting Bracket and Two Ball Joints																		
AM-803	9-3/4" damper Shaft Extension for 5/16"...1" Diameter Round Shafts																		
AM-804	Jackshaft Linkage (requires AM-805 Support Plate for Mx41-73xx Actuators)																		
AM-805	Support Plate for Mx41-73xx Actuators																		
BEL-ZTH	US Handheld Interface Module for Field Programming of the MS41-7303-xxx Models																		

a - For shafts up to 3/4" (19 mm) diameter round up to 1/2" (13 mm).
 b - Cannot be used when creating a linked valve/actuator assembly.

Damper Accessories

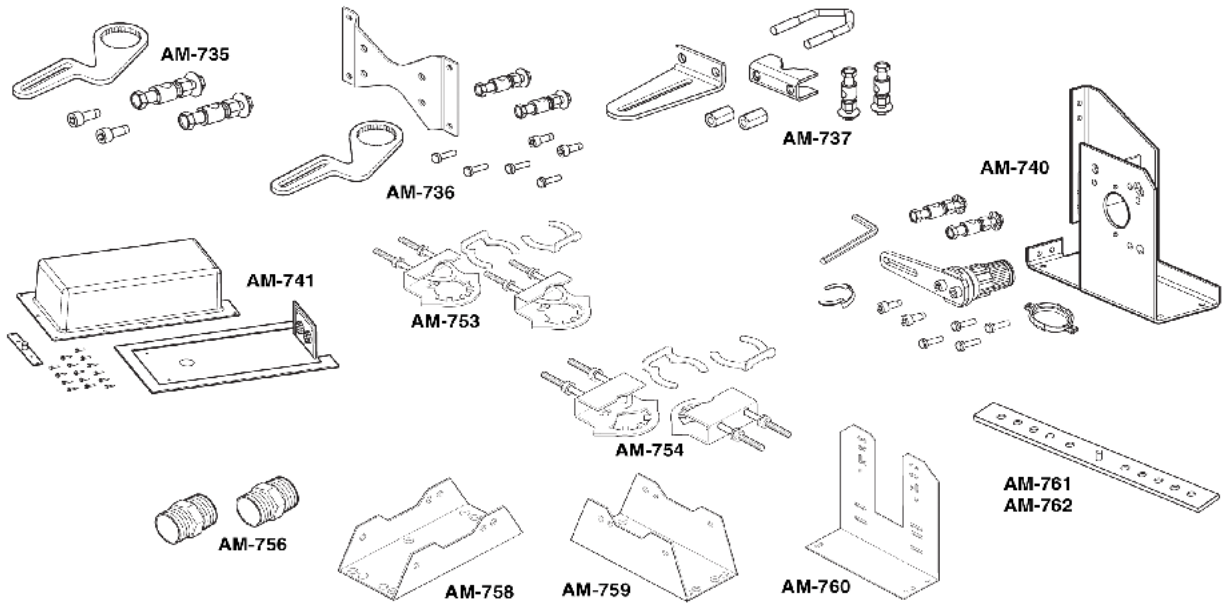

Part Number	Description	Spring Return Actuators								Non Spring Return Actuators							
		MA40-7043 MF40-7043	MS40-7043	MA41-7073 MF41-7073	MS41-7073	MA41-7153 MF41-7153	MS41-7153	MA40-717x MF40-7173	MS40-7173	MS4D-x033	MF41-6043 MS41-6043	MF41-6083	MS41-6083	MF41-6153 MS41-6153	MF41-6343	MS41-6343	
AM-735	Crank Arm Kit																
AM-737	Universal Crank Arm ^a																
AM-741	Weather Shield																
AM-753 ^b	Mounting Clamp																
AM-754 ^c																	
AM-756	Metric Conduit Adaptor																
AM-758	Short "U" Mounting Bracket																
AM-759	Tall "U" Mounting Bracket																
AM-760	Slotted "L" Mounting Bracket																
AM-761	7-inch Anti-rotation Bracket																
AM-762	9-inch Anti-rotation Bracket																

a - For Honeywell Floor Mount Mod. Motor.
 b - For shafts 3/8" (19 mm) round and 5/8" (15.9 mm) square.
 c - For shafts 3/8"...1/2" (10...13 mm) round and square.
 d - Only used on Mx41-707x-xxx, Mx41-715x-xxx.

Foot Mounted Actuators

Butterfly Valves are the ideal choice of product for isolation (on/off control) where needed within a plants heating system. The full range of Schneider Electric products can be electrically or manually operated.



Overview: Foot Mount Actuators

Product Overview

MA-3/4xx Series: These actuators provide two-position operation of dampers, valves, and other equipment requiring the return to normal position upon power interruption.

MC-351/421/431: These actuators provide two-position operation of dampers or valves in heating, ventilating, and air conditioning systems, and similar applications where return-to-normal position is not required.

MP-3xx Series, MP-4xx Series, MP-2xxx Series, and MP-4xxx Series: These actuators are used for two-position, floating, and proportional control of dampers, valves, and program switches in heating, ventilating, air conditioning, and similar applications. Hazardous location models offer a sturdy cast aluminum case with bolted cover. They have two 3/4" pipe tapped openings for joints with rigid metal conduit. All wiring is brought out to separate terminals for ease of installation. These factory enclosure and actuator assemblies are from Underwriters Laboratories Listed.

MP-9xxx Series Reversible and Proportional Electric Actuators: These actuators provide control of heavy dampers, large valves, and other high torque applications in heating, ventilating, air conditioning, and similar applications which do not require return to a normal position.

The CP-8301-xxx electronic actuator drive is designed to process a variable 2 to 15 Vdc signal from a controller to provide proportional control of an electric gear train actuator.

The CP-8391-913 electronic actuator drives are designed to process a variable 4 to 20 mA_{dc} signal from a controller to provide proportional control of an electric gear train actuator.

The CP-9301 and CP-9302 electronic actuator drives process a variable input signal from a controller to provide proportional control of an electric gear train actuator.

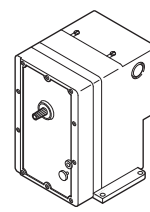

MA-3xx, MA-4xx (Standard)

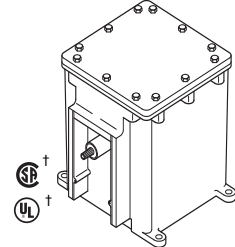

MA6-3xx, MA6-4xx, MA8-4xx, MA7-4xx
† Hazardous Locations

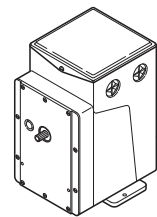

Spring Return MP-3/-4xxx Series, MP-2/-4xxx Series

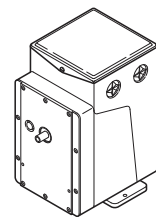

Non-Spring Return Spring Return MP-3/-4xxx Series, MP-2/-4xxx Series, MC-351/421/431

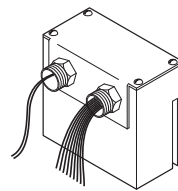

CP-8301-xxxx, CP-8391-913

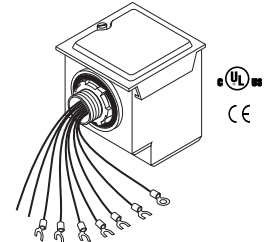

CP-9301/9302

MA-3/4xx Series Two-position Oil-Submerged Actuators

These actuators provide two-position operation of dampers, valves, and other equipment requiring the return to normal position upon power interruption.

Features

- SPST controller
- Spring return
- 24, 120 and 240 Vac models
- SPDT auxiliary switch if actuator part number suffix is “-500”
- Rugged die cast aluminum
- Oil immersed motor and gear train
- Models for hazardous locations are only available as a factory enclosure/actuator assemblies
- NEMA 4 with optional watertight conduit connectors, field supplies

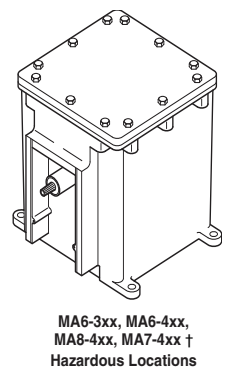
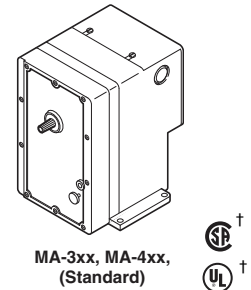

Specifications

Control circuit	24 Vac @ 50/60 Hz, 110/120 Vac @ 50/60 Hz, 220/230 Vac @ 50/60 Hz.
Spring return	CCW to original position when actuator is de-energized
Auxiliary switch (-500 models)	SPDT makes (or breaks) circuit at powered end of stroke (fixed)
Nominal damper area	Actuator sizing should be done in accordance with damper manufacturer's specifications
Environment	
Ambient temperature limits	
Shipping and storage	-40 to 136°F (-40 to 58°C)
Operating	-40 to 136°F (-40 to 58°C)
Humidity	5 to 95% RH, non-condensing
Locations	NEMA 4 ^a
Connections	Coded screw terminals
Case	Die cast aluminum with two 1/2 in. conduit openings Allow 6 in. (152 mm) clearance above the actuator wiring compartment Refer to Model Table for additional data
Mounting	
Dimensions	
Base actuators	5-3/4 H x 5-3/8 W x 6-9/16 D in. (146 x 136 x 167 mm)
Hazardous location actuators	8-7/8 H x 8-1/2 W x 10-5/8 D in. (225 x 216 x 167 mm)
No load timing at 75°F (24°C)	20 seconds
Agency Listings	UL 873 File E9429 Temperature Indicating and Regulating Equipment CSA C22.2 No. 24 File LR 3728 Installation Instructions F-06491
Installation Instructions	F-06491

a - When used with gasket (provided) and water-tight conduit connectors (not provided).

b - Spring return timing with full load opposing spring approximately 60 seconds.

Model table

Model No.	Power Supply		Aux.a Switch	Input (Watts)	Va Running/ Holding	Rated Torque lb-in. (N-m)	Application and Mounting	Shaft Rotation
	Vac	Hz						
MA-305	24	60	No	25	56/56	16 (1.8)	Damper actuators. Upright position preferred.	CW 180° when power is applied.
MA-305-500	24		Yes					
MA-405	120		No					
MA-405-500	120		Yes					
MA-318	24		No	70 Running 25 Holding	92/32	60 (6.8)	Damper and valve actuators. Output shaft horizontal.	CW 170° when power is applied.
MA-318-500	24		Yes					
MA-418	120		No					
MA-418-500	120		Yes					
MA-419	240		No		120/39			
MA-419-500	240		Yes					
MA5-419	240		50	No				

a - 2 FLA, 12 LRA at 24/120 Vac; 1 FLA, 6 LRA 2 240 Vac. † Models for hazardous locations are only available as factory enclosure/actuator assemblies.

Part Numbers for Hazardous Location Applications^{a,b}

Model No.	Damper Actuator Part Numbers for Hazardous Locations	Valve Actuator Part Numbers for Hazardous Locations
MA-305	-	-
MA-305-500	-	-
MA-405	-	-
MA-405-500	MA6-405-500	-
MA-318	-	-
MA-318-500	-	-
MA-418	MA6-418	MA8-418
MA-418-500	MA6-418-500	-
MA-419	-	-
MA-419-500	-	-
MA5-419	-	-

a - Class 1, Groups C and D, and Class 2, Groups E, F and G, hazardous locations. Ref. EN-56-2, F-18451.

b - Models for hazardous locations are only available as factory enclosure/actuator assemblies.

MC-351/421/431 NSR Two-Position Actuators

This actuator provides two-position operation of dampers or valves in heating, ventilating, and air conditioning systems, and similar applications where return-to-normal position is not required.

Features

- Two-position actuators controlled by SPDT controller
- Non-spring return
- 24 and 120 Vac models available
- SPDT auxiliary switch is standard
- Rugged die cast aluminum housings
- Oil immersed motor and gear train

Specifications

Control circuit	Three wire, SPDT snap acting switch provided by a thermostat, pressure switch, or relay
Shaft rotation	Unidirectional clockwise 180 when power is applied
Auxiliary switch	Adjustable SPDT is standard. Factory set to make (or break) at mid-stroke
Nominal damper area	Actuator sizing should be done in accordance with damper manufacturer's specifications
Environment	
Shipping and storage	-40 to 136°F (-40 to 58°C)
Operating	-40 to 136°F (-40 to 58°C)
Humidity	5 to 95% RH, non-condensing
Locations	NEMA Type 1. NEMA 4 with AM-363
Connections	Coded screw terminals
Case	Die cast aluminum with two 1/2 in. conduit knock-outs on each side Allow 6 in. (152 mm) clearance above the actuator wiring compartment
Mounting	Any position
Dampers	
Valves	In any upright position with actuator above the center line of the valve body
Dimensions	7 H x 5-3/8 W x 6-5/16 D in. (178 x 137 x 160 mm)
Installation instructions	F-08366

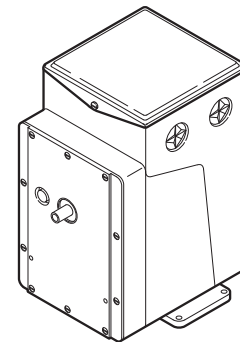

Model Table

Model No.	Input				No Load Timing (sec/180°)	Rated Torque lb-in. (N-m)
	Volts	Hz	Watts	VA Rating		
MC-351	24	60	28	53	70	220 (25)
MC-421	120	60	50	96	20	175 (19)
MC-431	120	60	50	96	30	220 (25)

Adjustable Auxiliary Switch SPDT Rating Amps

Type	120 V
Running	5.8
Locked Rotor	34.8
Non-Inductive	12.0

MP-3/-4xx, MP-2/-4xxx Series Reversible and Proportional Electric Actuators

The MP Series Actuators are used for two-position, floating, and proportional control of dampers, valves, and program switches in heating, ventilation, and air conditioning applications or similar applications.

Features

- Proportional actuators with built-in feedback potentiometers.
- Spring return and non-spring return models available.
- 24 Vac, 120 Vac, and 240 Vac models are available.
- Die cast housings with four 1/2 in. conduit openings.
- Oil-immersed motor and gear train.

Specifications

Input Control signals: Refer to the Model Table for input control signal capability versus specific actuator models.

Floating	Requires one Single Pole Double Throw (SPDT) switch with floating (center off) position rated at 0.9 amps at 24 Vac or two Single Pole Single Throw (SPST) switches rated at 0.9 amps at 24 Vac
Two-position SPDT SPST	Requires snap acting switch rated at 0.9 amps at 24 Vac Can be used with certain spring return actuators Switch must be rated to handle actuator power requirements
Microtherm Proportional	Electrical system with the following typical controllers: PP-22x Series, TP-1xx Series, TP-2xx Series, TP-3xx Series, TP-4xx Series, TP-1xxx Series, and TP-1xxxx Series Control of a single actuator
Standard Sequencing	Five-position used typically for adjustable minimum position (five positions) of an economizer actuator Control of two actuators in sequence
Slidewire and paralleling	Requires AE-504 paralleling relay AE-504 accepts 100Ω to 1000Ω slidewires
Voltage	Vdc (TAC System 8000) Requires CP-8301-xxx or CP-9301-xxx Series of solid state actuator drives. Refer to the Model Table
Current mAdc	Requires CP-9302-xxx Series of solid state actuator drives. Refer to the Model Table
Connections	MP-3xx, 4xx, 2xxx, 4xxx Coded screw terminals Models -600 Suffix Coded screw terminals except for input signal which are color coded pigtailed
Power requirements	Refer to the Model Table to determine power requirements
Torque	Refer to the Model Table to determine the actuator torque rating
Nominal damper area	Actuator sizing should be done in accordance with damper manufacturer's specifications
Spring return	Refer to the Model Table for models that are spring return
Environment Shipping and storage Operating Humidity	-40 to 160°F (-40 to 71°C) -40 to 136°F (-40 to 58°C) 5 to 95% RH, non-condensing
Locations	NEMA 1; NEMA 4 for non-spring return actuators with AM-363
Dimensions	NSR Models MP-3xx, 4xx, 2xxx, 4xxx 7 H x 5-3/8 W x 6-5/16 D in. (178 x 136 x 160 mm) SR Models -600 Suffix 7 H x 5-3/8 W x 8-1/8 D in. (178 x 136 x 206 mm) SR plus actuator drive housing
Agency listings	UL 873 File E9429 Temperature Indicating and Regulating Equipment CUL Canadian Standard #LR 3728 European Community EMC Directive 89/336/EEC and 92/31 EEC Low voltage Directive 72/23 EEC Units with a "-xxx-x-2" suffix identify models that are in compliance with CE Example: MP-xxxx-xxx-x-2
Installation instructions	F-15479

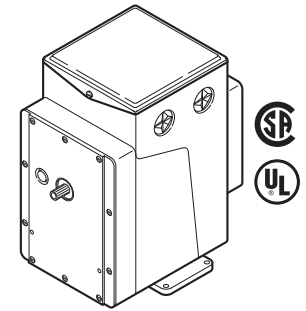

Spring return

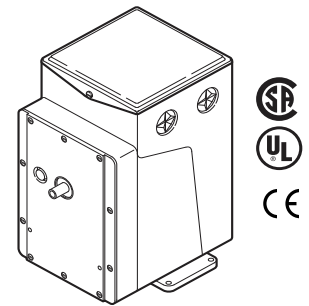

Non-spring return

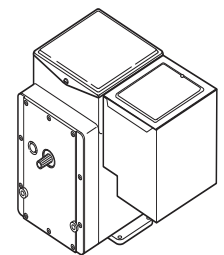

-6xx with CP-9301 or CP-9302 installed

Model Table MP-3xx Series

Model No.	Application	Solid State Drive CP-8301-xxx, CP-9301 CP-9302	Power Requirements			Output Shaft				Aux. Switch	Built-in Transformer ^a
			Volts	Hz	Amps	Torque lb.-in. (N-m)	Timing Seconds (No Load)	Degrees of Rotation	Spring Return		
MP-361	Proportional	Available	24	60	2.5	50 (5.6)	90	180 (Adj. ^b)	CW	SPDT	-
MP-371	Proportional	Available						180 (non Adj.)			
MP-371-600 ^c	Proportional	CP-8301-024 Included						180 (Adj. ^b)	No		
MP-381	Proportional	Available			2.2	220 (24.9)	130 to 1300	180 (Adj. ^b)		SPDT	

a - Units with a "-2" suffix, e.g., MP-xxxx-xxx-2-x, include a built-in transformer (used for Microtherm or with AE-504) with secondary loads wired externally to terminals seven and eight of the actuator. Red (24 Vac) to terminal eight and Blue (12 Vac) to terminal seven. When these actuators are used with controllers other than Microtherm or AE-504, disconnect the Red and Blue leads and tape off. Note: Models prior to "-2" suffix had transformer wired directly to potentiometer. To disconnect the transformer, remove the back plate of the actuator, disconnect, and tape the transformer leads.
b - Rotation adjustable 45 to 320. Caution: On actuators with proportional input signals changing the rotation will affect the control, since the internal feedback potentiometer's travel is fixed.
c - Integral solid state drive CP-8301 accepts 6-9 Vdc voltage with 20 Vdc power supply included.

MP-3/-4xx, MP-2/-4xxx Series Reversible and Proportional Electric Actuators

MP-4xx Series Model Table

Model No.	Application	Solid State Drive CP-8301-xxx, CP-9301, CP-9302	Power Requirements			Output Shaft				Aux. Switch	Built-in Transformer			
			Volts	Hz	Amps	Torque lb.-in. (N-m)	Timing Seconds (No Load)	Degrees of Rotation	Spring Return					
MP-423	Proportional	Available	120	60	0.65	60 (6.8)	13	90 (Adj. b)	No	SPDT	-			
MP-424							13 to 130							
MP-451							80							
MP-452						220 (24.9)	80 to 800							
MP-453							40							
MP-454							40 to 400							
MP-461-600	6 to 9 V Proportional	CP-8301-120 Included			0.5	50 (5.6)	90	180 (Adj. b)	CW	SPDT	-			
MP-465	Proportional	Available							180 (non-adj.)			No		
MP-471-600	6 to 9 V Proportional	CP-8301-120 Included												
MP-475	Proportional	Available												
MP-481	Proportional	Available						180 (Adj. b)	90 (Adj. b)			No	SPDT	-
MP-481-600	6 to 9 V Proportional	CP-8301-120 Included												
MP-483	Proportional	Available	65	130		180b	SPDT			Yes				
MP-485														
MP-495														
MP-495			0.95	450 (50.9)		130	180b							

a - Units with a "-2" suffix, e.g., MP-xxxx-xxx-2-x, include a built-in transformer (used for Microtherm or with AE-504) with secondary loads wired externally to terminals seven and eight of the actuator. Red (24 Vac) to terminal eight and Blue (12 Vac) to terminal seven. When these actuators are used with controllers other than Microtherm or AE-504, disconnect the Red and Blue leads and tape off. Note: Models prior to "-2" suffix had transformer wired directly to potentiometer. To disconnect the transformer, remove the back plate of the actuator, disconnect, and tape the transformer leads.

b - Rotation adjustable 45 to 320°. Caution: On actuators with proportional input signals changing the rotation will affect the control, since the internal feedback potentiometer's travel is fixed.

MP-2xxx Series

Model No.	Application	Solid State Drive CP-8301-xxx, CP-9301, CP-9302	Power Requirements			Output Shaft				Aux. Switch	Built-in Transformer
			Volts	Hz	Amps	Torque lb.-in. (N-m)	Timing Seconds (No Load)	Degrees of Rotation	Spring Return		
MP-2113-500	Proportional	Available	24	60	2.2	50 (5.6)	25	180 (non-Adj.)	No	SPDT	-
MP-2130-500			120		0.5			90 (non-Adj.)			
MP-2150-500			180 (non-Adj.)								

a - Units with a "-2" suffix, e.g., MP-xxxx-xxx-2-x, include a built-in transformer (used for Microtherm or with AE-504) with secondary loads wired externally to terminals seven and eight of the actuator. Red (24 Vac) to terminal eight and Blue (12 Vac) to terminal seven. When these actuators are used with controllers other than Microtherm or AE-504, disconnect the Red and Blue leads and tape off. Note: Models prior to "-2" suffix had transformer wired directly to potentiometer. To disconnect the transformer, remove the back plate of the actuator, disconnect, and tape the transformer lead.

MP-9xxx Series Reversible and Proportional Electronic Actuators

Reversible and Proportional Electric Actuators

These actuators provide control of heavy dampers, large valves, and other high torque applications in heating, ventilating, air conditioning, and similar applications which do not require return to a normal position.

Features

- High torque proportional gear train actuators accept the following signals:
 - 100 to 1,000 slidewire (requires AE-504).
 - SPDT floating or snap-acting controller.
 - Variable Vdc.
 - Variable mAdc.
- Torque to 1,600 lb-in.
- Available in 120 Vac models.
- Standard SPDT auxiliary switch.
- Rugged die cast aluminum housings.
- Oil immersed motor and gear train.

Specifications

Control circuit	Requires SPDT switch with neutral (floating) or two-position and proportional
Shaft Rotation	Reversible proportional can stop at any point in the stroke
Auxiliary switch	Adjustable SPDT snap-acting Factory set to close one contact and open the other at end of CW stroke.
Environment	
Shipping and storage	-40 to 130°F (-40 to 54°C)
Operating	-40 to 130°F (-40 to 54°C)
Humidity	5 to 95% RH
Locations	NEMA Type 1 (NEMA 4 with AM-369)
Connections	Coded screw terminals
Case	Die cast aluminum with two 1/2 in. conduit knock-outs on each side
Mounting	
Dampers	Upright preferred
Valves	Upright with actuator above the center line of the valve body
Dimensions	9-9/16 H x 9-1/2 W x 10-1/2 D in. (243 x 241 x 267 mm)
Agency Listing	MP-9750 only UL Listed
Installation Instructions	F-11331

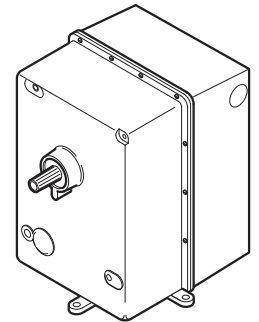

MP-9750 only

Model Table

Model No.	Control		Input	Torque Lb-in. ^a	Timing Sec.	Stroke	Misc.
	Type	Amp Rating					
MP-9750 ^b	1, 2	0.9 at 120 Vac	120 Vac, 60 Hz, 0.9 A	800	135	180	Built-in Trans. ^c
MP-9810	3, 4	1.8 at 120 Vac	120 Vac, 60 Hz, 1.8 A	1300	115	180	—
MP-9910				1600	145	180	

a - 1 lb-in. = 0.113 N-m.

b - U Listed.

c - Note: MP-9750-xxx-2-x includes a built-in transformer with secondary leads wired externally to terminals 7 and 8 — Red (24 Vac) to 8 and Blue (12 Vac) to 7.

Compatible Actuators

Actuators	Actuator Drives Input Type		
	Vdc	Vdc/mA	mA/Vdc
Actuator Model	CP-8301-xxx ^a	CP-9301	CP-9302
MP-9750	X	X	X
MP-9810	—	—	—
MP-9830			
MP-9910			

a May require close nipple conduit extensions for mounting x-6680.

CP-8301 2 to 15 VDC Electronic Actuator Drive

2–15 Vdc Input Electronic Actuator Drive

The CP-8301-xxx Series electronic actuator drive is designed to process a variable 2 to 15 Vdc signal from a controller to provide proportional control of an electric gear train actuator.

Features

- Mounts directly onto proportional, electric, gear train actuators.
- 24 and 120 Vac models available.
- Color-coded pigtail leads.

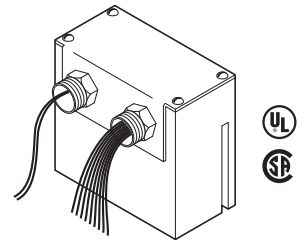

Specifications

Inputs Control signal	
Range	2 to 15 Vdc
Span, Start point	Refer to Model Table
Power requirements	Refer to Model Table
Power supplies	Refer to Model Table
Outputs	
Connections	Color coded pigtail leads.
Mounting	Directly to an actuator
Case	Bakelite
Connections	Adjustable SPDT snap-acting Factory set to close one contact and open the other at end of CW stroke.
Environment	
Shipping and storage	-40 to 140°F (-40 to 60°C)
Operating	-40 to 140°F (-40 to 60°C)
Humidity	5 to 95% RH, non-condensing
Locations	NEMA Type 1
Dimensions	4 H x 4 W x 3-1/4 D in. (102 x 102 x 83 mm)
Agency Listing	
UL	File #E9429 Category Temperature-Indicating and Regulating Equipment
CSA	C22.2 No. 24-93
Installation Instructions	F-14940

Model Table

Model No.	Power Requirement Vac, 4.8 VA 50/60 Hz (+10/-15%)	Power Supply ^a	Start Point of Actuator	Span
CP-8301-024	24	20 Vdc, 50 mA regulated and filtered.	Adjustable from 2 to 12 Vdc input. Factory set at 6 Vdc.	Fixed at 3 Vdc for full actuator stroke.
CP-8301-120	120			

a - The power supply must not be connected to +20 (red) of other supplies.

Compatible Actuators

Actuator Series	Power		Torque		Stroke Degrees	Spring Return
	Vac 60 Hz	Amp	Lb-in.	N-m		
MP-2113-500	24	2.2	50	5.6	180	-
MP-361		2.5				220
MP-371			0.5	220		
MP-381		120				0.95
MP-465 ^a	120		0.9	-	-	
MP-475 ^a		180				-
MP-483 ^a	180		-	-	-	
MP-485 ^a		180				-
MP-495 ^a	180		-	-	-	
MP-9750 ^a		180				-

a - CAUTION: Remove red and blue transformer wires from terminals 7 and 8 of actuator and tape.

CP-8391-913 Series Electronic Actuator Drive

The CP-8391-913 electronic actuator drive is designed to process a variable 4 to 20 mAdc signal from a controller to provide proportional control of an electric gear train actuator.

Features

- Mounts directly onto proportional, electric, gear train actuators.
- Fixed 4 to 20 mAdc operating range with 250Ω impedance.
- 24 and 120 Vac models available.
- Color-coded pigtail leads.

Specifications

Inputs Control signal	
Range	4 to 20 mAdc, non-adjustable
Span	16 mAdc
Start point	4 mAdc
Impedance	250 Ω
Grounding	Either input wire can be grounded and will not cause damage, provided the electric gear train actuator is ungrounded
Hysteresis	6 to 9% of 16 mAdc span, nonadjustable (Hysteresis is the difference in input signal between that signal which will drive the actuator shaft one way and the signal which will drive it the other way)
Power requirements	Refer to Model Table
Power consumption	Refer to Model Table
Linearity	0.15% of 16 mAdc span
Outputs	To control windings of gear train actuators, see "Typical Actuators"
Connections	Color coded pigtail leads
Mounting	Directly to an actuator. The upright position is preferred, but other positions are acceptable
Case	Bakelite
Environment	
Shipping and storage	-40 to 140°F (-40 to 60°C)
Operating	-40 to 140°F (-40 to 60°C)
Humidity	5 to 95% RH, non-condensing
Vibration	1G maximum in any plane
Agency Listing	
UL 873	File #E9429 Category Temperature-Indicating and Regulating Equipment
CSA	C22.2 No. 24-93
Installation Instructions	F-22453

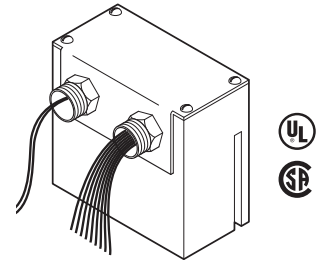

Model Table

Model No.	Power Requirement Vac, 50/60 Hz (+10/- 15%)	Power Consumption	Start Point of Actuator	Span
CP-8391-913	24	4.8 VA	Factory set at 4 mAdc non-adjustable.	Fixed at 16 mAdc for full actuator stroke.

Compatible Actuators

Actuator Series	Power		Torque		Stroke Degrees	Spring Return
	Vac 60 Hz	Amp	Lb-in.	N-m		
MP-2113-500 ^a	24	2.2	50	5.6	180	-
MP-361 ^a		2.5				220
MP-371 ^a			0.5	220		
MP-381 ^a		120				0.95
MP-465 ^{a,b}	120		0.9	800	90	
MP-475 ^{a,b}		120				0.9
MP-483 ^{a,b}	120		0.9	800	90	
MP-485 ^{a,b}		120				0.9
MP-495 ^{a,b}	120		0.9	800	90	
MP-9750 ^a		120				0.9

a - CP-9301 may be an alternative solution.

b - CAUTION: Remove red and blue transformer wires from terminals 7 and 8 of actuator and tape.

CP-9301 Series Electronic Actuator Drive

The CP-9301 and CP-9302 electronic actuator drives process a variable input signal from a controller to provide proportional control of an electric gear train actuator. The CP-9301 is preset at the factory for voltage input. The CP-9302 is factory preset for current input and has additional wiring for connection to an override switch, for those applications requiring an external override of the input signal. These drives are equipped with built-in jumpers and adjustable potentiometers, so that the type of input signal, deadband, input span, and start point may be reset in the field when necessary.

Features

- Mounts directly onto proportional, electric, gear train actuators.
- Power is supplied directly from the actuator.
- Jumpers for selecting either voltage or current input, as well as 3% or 5% deadband.
- Adjustable span and start point potentiometers.

Specifications

Mounting	Directly to an actuator. The drive may be mounted on either the left or right side of the actuator, in a conduit opening adjacent to the low voltage wiring compartment.
Case	Injection molded plastic with stamped aluminum cover
Inputs Control signal	
Span	Refer to Model Table
Start point	Refer to Model Table
Impedance	
Voltage Input	Greater than 10,000 Ω
Current Input	250 Ω
Power supply	Power shall be supplied directly from the shading coil windings provided on the shaded pole reversible motor of the gear train actuator (less than 30 Vac)
Outputs	
Connections	Color-coded leads with crimped screw terminal connectors
Shading Coil Triac Output	Purge override (input signal override) leads are color-coded pigtailed
Deadband	1.2 A RMS
Deadband	Refer to Model Table
Connections	Color coded pigtail leads
Environment	
Shipping and storage	-40 to 160°F (-40 to 71°C)
Operating	-40 to 136°F (-40 to 58°C)
Humidity	5 to 95% RH, non-condensing
Locations	NEMA Type 4; IEC IP56.
Agency Listing	
UL 873	File #E9429 Category Temperature-Indicating and Regulating Equipment
CUL	C22.2 No. 24-93
European community	EMC Directive 89/336/EEC
Installation Instructions	F-26563

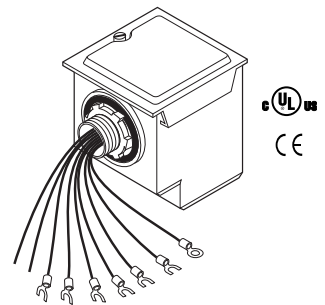

Model Table

Part Number	Input Signal Override	Factory Jumper Settings				Jumper Settings		Potentiometer Adjustment Ranges	
		Input Signal	Deadband	Start Point	Input Span	Input Signal	Deadband	Input Span	Start Point
CP-9301	Not Available	Voltage (6 to 9 Vdc)	3% of Input Span	6 Vdc	3 Vdc	Voltage or Current	3% or 5% of Input Span	3.0 to 16.5 Vdc or 8 to 16 mAdc	0 to 10 Vdc or 2 to 16 mAdc
CP-9301-456		Voltage (0 to 10 Vdc)		0 Vdc	10 Vdc				
CP-9302	Available (Use is Optional)	Current (4 to 20 mAdc)	5% of Input Span	4 mAdc	16 mAdc				
CP-9302-702									

Compatible Actuators

Actuator Series	Power		Torque		Stroke Degrees	Spring Return	Internal Transformers
	Vac 60 Hz	Amp	Lb-in.	N-m			
MP-2113-500	24	2.2	50	5.6	180	–	No
MP-361	24	2.5	50	5.6	180	CW	No
MP-371	24	2.5	50	5.6	180	CCW	No
MP-381	24	2.5	220	24.9	180	–	No
MP-465	120	0.5	50	5.6	180	CW	Yes
MP-475	120	0.5	50	5.6	180	CCW	No
MP-483	120	0.5	220	24.9	90	–	Yes
MP-485	120	0.5	220	24.9	180	–	Yes
MP-495	120	0.95	450	50.8	180	–	Yes
MP-9750	120	0.9	800	90.3	180	–	Yes

a - Units with a "-2" suffix, e.g. MP-xxxx-xxx-2-x, include a built-in transformer (used for Microtherm® or with AE-504) with secondary leads wired externally to terminals 7 (Blue, 12 Vac) and 8 (Red, Vac) of the actuator. Caution: When using the CP-9301 or CP-9302 with actuators containing an internal transformer, disconnect and tape off the red and blue leads before installing and powering the device. Failure to do so can result in damage to the actuator drive. Note: Models prior to "-2" suffix had transformer wired directly to potentiometer. To disconnect the transformer, remove the back plate of the actuator, then disconnect and tape the transformer leads.

Zone Valves and Actuators

Zone valves and actuators from Schneider Electric give customers performance, versatility, and a patented “PopTop” actuator technology that revolutionized the zone valve market.

Options and efficiency certainly describes the zone valve and actuator range. It boasts the industry's best temperature ratings, Schneider Electric's global zone valve and actuator ensure HVAC applications including chilled, hot water, and low pressure/low temperature steam applications deliver optimal comfort.



PopTop™



Erie's motorized hydronic valves, the PopTop™, provides convenient, reliable and easy installation for a variety of heating and cooling applications. Installation is a snap with easy, one-handed removal or engagement of the actuator to the valve body. Push the button and lift. It's that simple.

Features

- One-handed engagement or removal of the motorized actuator to the valve body.
- Valve actuator can be easily attached after the valve body has been installed into the system.
- Mounts quickly and easily without the need of linkages or calibration.
- Available in 2-way and 3-way port configurations, 1/2" (15mm) through 1-1/4" (32mm) sweat or 1/2" (15mm) to 1" (25mm) threaded connections, 1.0 to 8.0 Cv range.
- Available factory coupled, or as individual bodies and actuators.
- Direct replacement for all existing PopTop™ applications.
- Rugged 400 PSIG rated brass forged body design for long life.
- UL listed actuator.

Erie Family of Products



PopTop™ Zone Valves

- 1/2", 3/4", 1" and 1-1/4" Sweat, NPT and Inverted Flare Union.
- Two-position (on/off), 2-way and 3-way.
- General close-off or High close-off.
- Low voltage or line voltage.



PopTop™ Modulating Valves

- 1/2", 3/4", and 1-1/4" Sweat, NPT.
- Three-wire (on/off), 2-way and 3-way.
- 0-10, 0-5, 5-10 Vdc or 4-20 mA proportional inputs.
- Spring return or non-spring return.
- Time out feature available.

PopTop™ Two Position Valves & Actuators



General Close-Off

For your residential and commercial applications, Erie's General Close-Off valves and actuators offer precision control for 2-position (on/off) spring return temperature control. The General Close-Off may be used in a wide range of applications such as radiant baseboard and fan coil for easy installation and maintenance.



High Close-Off "HCO"

For high-rise and commercial applications, where higher close-off is required, our High Close-Off valves and actuators offer precise temperature control. Our two-position (on/off) "HCO" actuator may be interchanged with General Close-Off actuators. This may be used in applications such as fan coil and VAV reheat.

Features

- Direct replacement for all existing two-position, motorized PopTop applications.
- Sized to fit most baseboard applications.*
- Rugged Brass forged 400 psig rated valve body.
- Up to 60 PSI (75 PSI for HCO valves and actuators) pressure differential close-off
- Spring return operation, normally closed or normally open.
- Voltages 24 to 277 VAC.
- End switch option on general temperature models.
- Terminal block option on general temperature models (24V).
- Chilled, hot water, and low pressure/low temperature steam applications.
- Cv 1.0 to 8.0.
- Hysteresis synchronous motor design for long life.
- Meets or exceeds ANSI IV standard for close-off.
- UL Listed actuator.

* General Close-Off Valves & Actuators only.

Modulating Zone Valve Assembly Ordering

Specify three part number fields for the Valve and three for Actuator Assembly part number

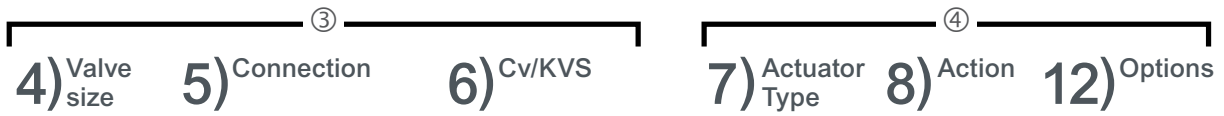

Ordering Modulating Zone Valve Assemblies

VM2 | | | | **3A00** | | | ①

Body Type
M = Modulating

Configuration
2 = 2-Way

Valve size
2 = 1/2"
3 = 3/4"
4 = 1"
5 = 1 1/4"

Connection	Availability
1 = Sweat	1/2", 3/4", 1", 1 1/4"
2 = Threaded	NPT 1/2", 3/4", 1"

Cv Size (Kvs)			
	2-way / 3-way	Size	Connection Type
1 =	1.0 (0.8)	1/2"	1, 2
2 =	2.0 (1.7)	3/4"	
3 =	4.0 (3.5)	1/2"	1
		3/4"	
7 =	7.5 (6.5)	1"	1, 2
		3/4"	
		8.0 (7.0)	1 1/4"

Actuator Type
 T = Three-wire Floating
 P = Proportional, 0-10 VDC, 0-5 VDC, 5-10 VDC or 4-20 mA, Jumper Selectable

Electrical Leads
00 = No leads

Voltage
A = 24 Vac only 50/60 Hz

Temperature Ratings
3 = General Temperature

Action
 1 = Spring Return Normally closed, 2-way or 3-way
 2 = Spring Return Normally opened, 2-way only
 3 = Non-Spring Return

Options
 Non-Spring Return Actuators
 0 = No Options
 T = Three-Wire Signal Time-Out
 Spring Return Actuators
 T = Time-Out

Available Actuators ②

Part number	Action	Actuator type	Option
AT13A00T	Spring Return	Three Wire Floating	With Time-Out
AT23A00T	Spring Return	Three Wire Floating	With Time-Out
AT33A000	Non-Spring Return	Three Wire Floating	None
AT33A00T	Non-Spring Return	Three Wire Floating	With Time-Out
AP13A000	Spring Return	Proportional	None
AP23A000	Spring Return	Proportional	None
AP33A000	Non-Spring Return	Proportional	None

- ① This feature is standard for floating spring return actuators and must be included in the part number.
- ② If the actuator doesn't have a time-out feature then the controller needs to have a time-out feature.
- ③ When ordering only a valve body make selections for the 3 configurable fields shown to derive a 6-digit number.
- ④ When ordering only an actuator, prefix with the letter A then make selections for the 3 configurable fields shown, to derive a 6-digit number (the 5th position is a double zero).

Specify Five Part Number Fields for the Valve and Six for a 2-Position Zone Valve Assembly Part Number

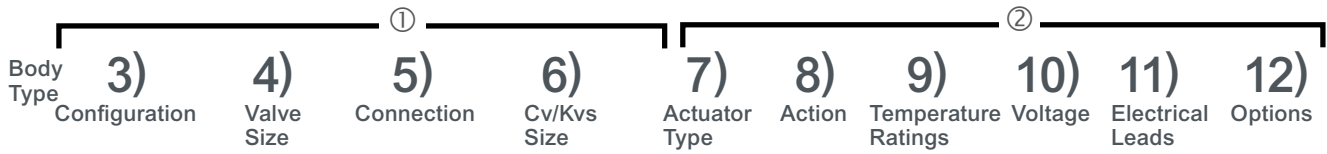

Ordering 2-Position Zone Valve Assemblies

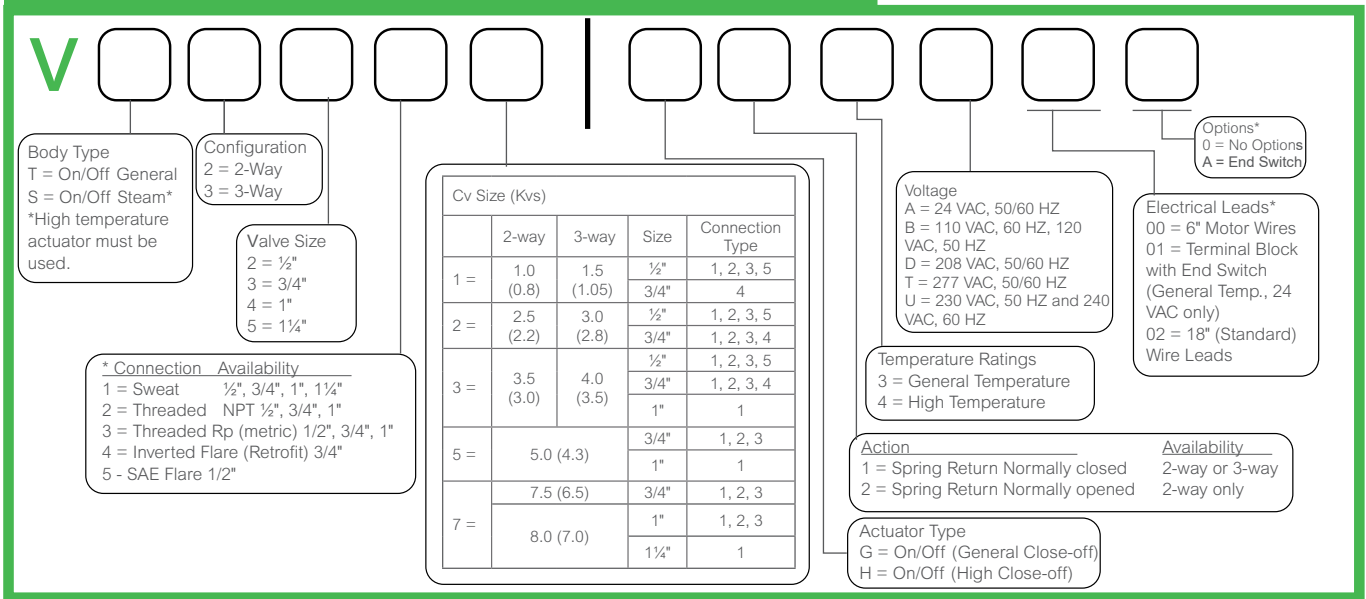

Body & Actuator Combination Requirements

Temperature Configurations	
Body Configuration	Actuator Spring Return Mode
V T X X X	A X X 3 X X X X
T = General	3 = General Temperature
S = Steam	4 = High Temperature
If body configuration is T, actuator temp. rating can be 3 or 4	If actuator temp rating is 3, body style must be T
If body configuration is S, actuator temp. rating must be 4.	If actuator temp rating is 4, body style must be S or T

- When ordering only a valve body make selections for the five configurable fields shown to derive a 6-digit number.
- When ordering only an actuator, prefix with the letter A then make selections for the six configurable fields shown, to derive a 6-digit number.

* Notes:

- Inverted Flare fittings must be ordered separately. See actuator accessories for fitting part numbers.
- End switch is not available for 277 Vac models if actuator temperature rating is high temperature (4).
- Actuators with terminal blocks required end switch and the end switches is 24 Vac @ 101 mA min. -5A max.
- End switch is 24-240 Vac @ 101 mA min. to 5 A max. and 9-30 Vdc @ 100 mA max. for actuators rated 240V or less. End switch is 277 Vac @ 101 mA min. to 5A max. for actuators rated 277 V.

Erie VM PopTop Series Modulating Valves Floating “T” & Proportional “P”

Standard and Spring Return Modulating Valves

Product Description

The Erie™ Modulating PopTop™ Series valve actuator assemblies are designed for closed hydronic heating and cooling systems. The Modulating PopTop is used to control fluid flow in fan coil units, VAV reheat, unit ventilators, AHUs and radiant applications.

The Modulating PopTop Proportional (P) type is compatible with any 0 to 10 Vdc or 4 to 20 mA signal with jumper selectable operating range and action resulting in precise positioning. The floating (T) type is compatible with any 24 Vac three-wire signal when three minute time-out logic resides in the valve actuator or system controller.

The Modulating PopTop valve assemblies allow the actuator to be snapped onto, or off from, the valve body. The actuator can be mounted after the valve body has been installed into the system without the need for linkages or calibration.

Available in standard (non-spring return) and spring return modulating actuators. The two-way spring return modulating actuators are provided in either normally open or normally closed operation. The three-way valves are available in normally closed operation only. Valve body reversal provides normally open flow for three-way valve bodies.

Features

- Magnetic clutch to maximize the life of the motor and gear train
- Manual operating lever/position indicator facilitates field setup
- Easy to use lever terminal blocks
- Actuator can be installed after the valve body
- Three wire floating and 0 to 10 Vdc or 4 to 20 mA proportional available
- Spring return will return actuator to normal position when the power is lost for more than two minutes.

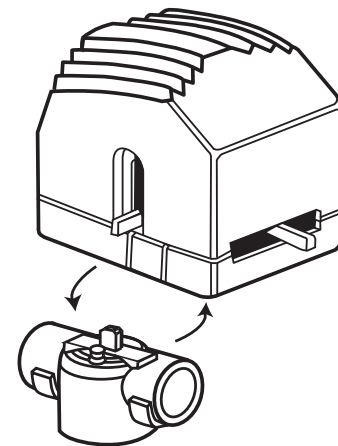

Spring Return

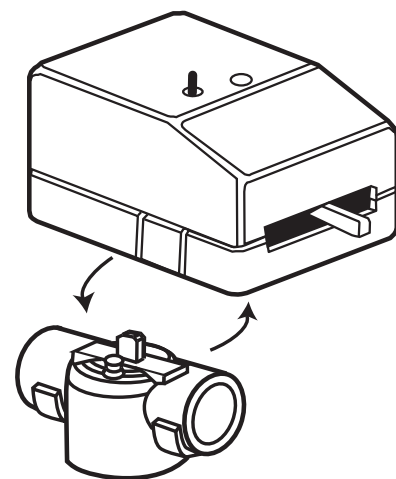

Non-Spring Return

Erie VM PopTop Series Modulating Valves Floating “T” & Proportional “P”

Specifications

Timing:	
Mechanical Action	
T series	Direct acting
P series	Direct acting (valve opens port B with increase in signal.) Field selectable reverse acting
Manual Override	Allows manual positioning
Operating Pressure Limits	400 psi (2758 kPa) static pressure.
Material	
Actuator	High temperature plastic
Valve	
Body	Forged brass
Stem	nickel-plated/chrome-plated brass
Seat	brass
Plug/paddle	High temperature thermoplastic/rubber
Flow Characteristic	1.0 to 4.0 Cv: equal percentage. 7.0/8.0 Cv: linear

Environment	
Ambient Temperature Limits	
Shipping & Storage	-40 to 158°F (-40 to 70°C)
Operating	35 to 125°F (2 to 52°C)
Fluid	32 to 200° F (0 to 93° C) (not steam rated)
Humidity	5 to 95% RH, non-condensing.
Seat Leakage	ANSI class IV (0.01%)
Shipping Weight	1.9 lbs (860 g), actuator and valve body
Location	NEMA Type 1
Agency Listings (Actuator Only)	
North America	c-UL-us LISTED per UL 60730-1 & -2-14 and CSA/CAN E60730-1 & -2-14. FCC Part15 ClassB and ICES-003 ClassB compliant.
Plenum	Rated per UL 2043 testing.
European Union	LVD 2014/35/EU and EMC 2014/30/EU directives, per EN 60730-1 & -2-14. EN 6100-6-2 immunity & EN 61000-6-3 emissions complaint.
Australia/New Zealand	This product meets requirements to bear the RCM mark.

Inputs

Floating Actuator			Control Circuit, Max.		Total Actuator, Max.	
Series	Action	Vac	mA	VA	Powerup Inrush VA	Running VA
AT13A00T	Spring Return	24 Vac +25%/-15% 50/60 Hz	24	0.6	10	1.9
AT23A00T			24	0.6		1.9
AT33A000	Non- Spring Return		-	-	1.0	1.0
AT33A00T			-	-	1.2	1.2

a - Transformer must be sized for Powerup Inrush

Proportional Actuator			Control Circuit, Max.		Total Actuator, Max.	
Series	Action	VAC	Range	Rin	Powerup Inrush VA	Running VA
AP13A000	Spring Return	24 Vac +25%/-15% 50/60 Hz	0-10 VDC or 0-5 VDC or 5-10 VDC or 4-20 mA	>200K >200K >200K 300	10	1.7
AP23A000					1.7	
AP33A000	Non-Spring Return				1.7	

a - Transformer must be sized for Powerup Inrush
b - Factory supplied. Actual range is 1-9 Vdc.

Erie VM PopTop Series Modulating Valves Floating “T” & Proportional “P”

Outputs

Series	Mode	Action	Nominal Stroke Time		Total Run Time	
			60 Hz	50 Hz	60 Hz	50 Hz
AT13A00T	Floating	Spring Return	2 min. 30 sec.	3 min.	3 min.	3 min. 36 sec.
AT23A00T						
AT33A000		Non-Spring Return			No delay	
AT33A00T					3 min. ± 30 sec.	n/a
AP13A000	Modulating	Spring Return	2 min. 45 sec.	3 min.	2 min. 45 sec.	3 min. 18 sec.
AP23A000						
AP33A000		Non-Spring Return				

Table 1. Flow Coefficients & Maximum Close-Off Differential Pressure.

Valve Size in.	Connection Type	Flow Coefficient Cv (kv)	Maximum Close-Off DP, PSI (kPa)		
			Non-Spring Operating Mode (Driven Close)	Spring Return Operating Mode (Driven Closed)	Spring Return Power Failure Mode* (Spring Close) PSID
1/2	NPT, SW, SAE, Rp	1.0 (0.9)	50 (344)	50 (344)	50 (344)
1/2	NPT, SW, SAE, Rp	2.0 (1.8)	50 (344)	50 (344)	20 (138)
3/4	NPT, SW, Rp				
1/2	NPT, SW, SAE, Rp	4.0 (3.5)	35 (241)	35 (241)	20 (138)
3/4	NPT, SW, SAE, Rp				
1	SW				
3/4	NPT, SW, Rp	7.5 (6.5)	35 (241)	35 (241)	15 (103)
1	SW, Rp	8.0 (6.9)	35 (241)	35 (241)	15 (103)
1-1/4	SW				

*If valve is driven closed before a power failure, the "operating mode" close-off pressures apply.

Valve Body Legend

NPT — Threaded

SW — Sweat

SAE — Society Automotive Engineers.

Rp—"Metric" Threaded

Erie VM PopTop Series Valve Bodies and Actuators

Product Description

Erie™ PopTop™ Series valve bodies and actuators provide easy installation for a variety of heating and cooling applications. The valve's actuator can be installed after the valve body has been installed onto the fan coil, baseboard or air handler. VS Series valves are available for low pressure steam applications. PopTop Series are two position spring return valves. When powered, the actuator moves to the desired position, tensing the spring return system. When power is removed the actuator returns to the normal position. PopTop Series two position spring return valves can be purchased with an optional built-in auxiliary SPDT end switch for interfacing or signaling; for example, zone pump burner control. Actuators are designed for cycling applications (not constantly powered).

Features

- Direct replacement for all existing two-position PopTop applications
- Hysteresis synchronous motor for long life
- Spring return operation provides a fail-safe
- Valve body rated for 400 psi static pressure
- Available in a variety of voltages
- Actuator mounts directly onto valve body without need for linkages or calibration
- Manual override lever (normally closed only)
- Actuator can be replaced without any tools, or removal of valve from system
- VS Series available for low pressure steam

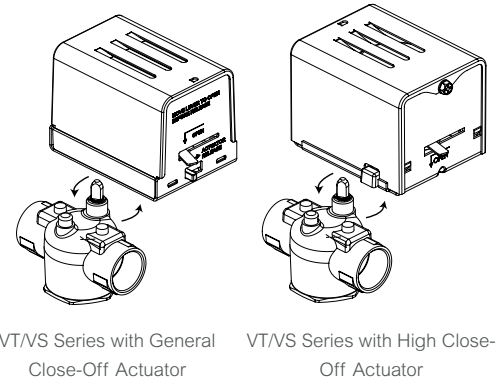

Specifications

Service	Hot and chilled water models, up to 50% glycol. Steam models up to 15 psi (both valve body and valve actuator must be rated for high temperature)
System Static Pressure Limits	400 psi (2758 kPa)
Fluid/Ambient Temperature Limits	See Table 1
Close-off	See Table 2
Seat Leakage	ANSI class IV (0.01%) with pressure at inlet (B-port/A-port, if 3-way)
Body	Forged brass
Stem	Nickel-plated
Seat	Brass
Paddle (VT series) (VS series)	Buna N Highly saturated nitrile
Actuator Voltage	24 Vac @ 50/60 Hz, 110 Vac @ 50 Hz, 120 Vac @ 60 Hz, 230 Vac @ 50 Hz, 240 Vac @ 60 Hz, 208 Vac @ 50/60 Hz, 277 Vac @ 50/60 Hz
Power Requirements	6.5 watts, 7.5 Va

Agency Listings	UL873	Underwriters laboratories (File #E9429 Category Temperature Indicating and Regulating Equipment).
	CUL	UL Listed for use in Canada by Underwriters Laboratory. Canadian Standards C22.2 No. 24. EMC Directive (89/336/EEC). Low Voltage Directive (72/23/EEC).
European Community	Australia	This product meets requirements to bear the RSM Mark according to the terms specified by the Communications Authority under the Radio Communications Act of 1992.
Shipping Weight (Actuator/Valve Assembly)		2.25 lbs (1020 g).

Table 1: Valve Body and Actuator Models

Model	Temperature Range
VTxxxx	32×...200°F (fluid) @ 104 °F (Ambient) (0...93°C @ 40°C)
VSxxxx	32×...250°F (fluid) @ 169 °F (Ambient) (0...121°C @ 76°C), and/or 15 PSI (103 kPa) Steam ^a
Axx3xxx	32×...200°F (fluid) @ 104 °F (Ambient) (0...93°C @ 40°C)
Axx4xxx	32×...250°F (fluid) @ 169 °F (Ambient) (0...121°C @ 76°C), and/or 15 PSI (103 kPa) Steam ^a

^a For steam applications both valve body and valve actuator must be rated for high temperature. Example: VS2213G14A020 = Assembly. VS2213 = Valve body. AG14A020 = Actuator.

Erie VM PopTop Series Valve Bodies and Actuators

Accessories for Inverted Flare Connection Valves

3/4" inverted flare bodies accept the following adapters to copper pipe:

436-214-1	Union nut & elbow assembly, female for 1/2" (5/8" O.D.) copper, 15/16" long
436-220	Union nut & coupling assembly, female for 1/2" (5/8" O.D.) copper, 1-1/16" long
436-252	Union nut & coupling assembly, female for 3/4" (7/8" O.D.) copper, 1-27/32" long
436-229-3	Union nut & nipple assembly, male for 1/2" (5/8" O.D.) copper, 3" long
436-214-4	Union nut & elbow assembly, male for 1/2" (5/8" O.D.) copper, 1-15/16" long
436-256	Union nut & coupling assembly, female for 1" (1-1/8" O.D.) copper, 1-3/8" long

Table 2: Flow Coefficients and Maximum Close-Off Pressure Differentials

Valve Size	Connection Type	2-way Cv (kv)	3-way Cv (kv)	(G) Close-Off ΔP PSI (kPa)	(H) PSI Close-Off ΔP (kPa)
1/2"	NPT, SW, Rp, SAE	1.0 (0.9)	1.5 (30)	60 (414)	75 (517)
3/4"	IFL				
1/2"	NPT, SW, Rp, SAE	2.5 (2.2)	3.0 (2.6)	40 (276)	50 (344)
3/4"	NPT, SW, IFL, Rp				
1/2"	NPT, SW, SAE, Rp	3.5 (3.0)	4.0 (3.4)	25 (172)	30 (208)
3/4"	NPT, SW, IFL, Rp				
1"	SW	5.0 (4.3)	5.0 (4.3)	20 (137)	25 (172)
3/4"	NPT, SW, Rp				
1"	SW	7.5 (6.5)	7.5 (6.5)	17 (117)	20 (137)
3/4"	NPT, SW, Rp				
1"	NPT, SW, Rp	8.0 (6.9)	8.0 (6.9)	17 (117)	20 (137)
1-1/4"	SW				

NPT - Threaded (female)

SW - Sweat

IFL - Inverted Flare

SAE - Society of Automotive Engineers Flare (male)

Rp - "Metric" Threaded (female)

G - General close off actuator

H - High close off actuator

Table 3: Water Valve Sizing*

ΔP	1.0 Cv	1.5 Cv	2.5 Cv	3.0 Cv	3.5 Cv	4.0 Cv	5.0 Cv	7.5 Cv	8.0 Cv
1 PSI	1.0	1.5	2.5	3.0	3.5	4.0	5.0	7.5	8.0
2 PSI	1.4	2.1	3.5	4.2	4.9	5.7	7.1	10.6	11.3
3 PSI	1.7	2.6	4.3	5.2	6.1	6.9	8.7	13.0	13.9
4 PSI	2.0	3.0	5.0	6.0	7.0	8.0	10.0	15.0	16.0
5 PSI	2.2	3.4	5.6	6.7	7.8	8.9	11.2	16.8	17.9

* Water capacity in gallons per minute (GPM)

Erie™ PopTop, 2/3-Way VM SR/NSR Assembly Flow Patterns

Modulating Spring and Non-Spring Return PopTop, Two-Way and Three-Way VM Assemblies Flow Patterns

Piping

- The three-way is only configured as normally closed. For normally open configuration to the coil, turn the valve around. For proportional valves, set the control action (direct or reverse accordingly).
- The valve should be used in a closed-loop system.
- All valves must be piped so the plug closes against the direction of flow. For two-way valves, flow is from port B to port A. For normally closed three-way valves, B is the service port and A is the bypass port. For normally open three-way valves, A is the service port and B is the bypass port.
- Three-way VM valves must be piped in a mixing configuration, not diverting.

⚠ CAUTION

RISK OF EQUIPMENT DAMAGE

Do not use VM series valves in “open” systems. Excess make-up water may cause damage to the valve.

Follow proper water treatment practices and system procedures. Refer to document F-26080; EN205, Water and Steam System Guidelines.

Failure to follow these instructions can result in equipment damage.

Note: Normally open actuators are not to be used on three-way valves to achieve normally open configurations. Use a normally closed actuator and pipe as shown in Figure-2.

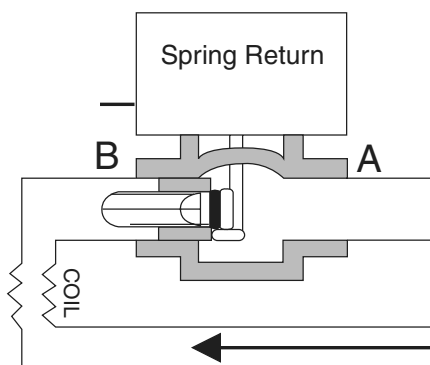

Figure 1 Two-Way Valve Normally Closed.

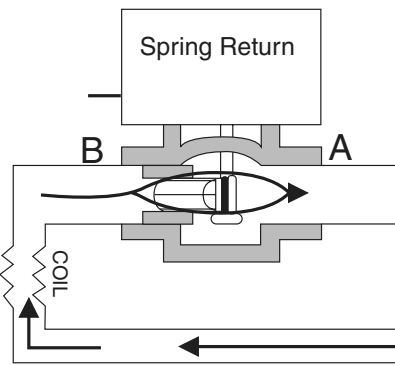

Figure 2 Two-Way Valve Normally Open.

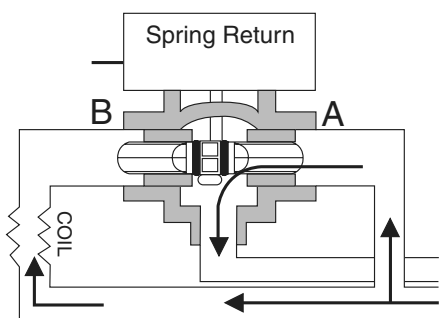

Figure 3 Three-Way Valve
B Port Piped to Coil Outlet
Normally Closed.

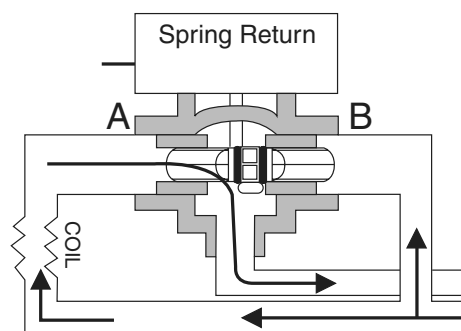

Figure 4 Three-Way Valve
A Port Piped to Coil Outlet
Normally Open

Erie™ PopTop, 2/3-Way VT/VS Two Position SR Assembly Flow Patterns

Two-Position Spring Return PopTop Two-Way and Three-Way VT/VS Assemblies Flow Patterns

The VT/VS series are two-position spring return valves. When powered, the actuator moves to the desired position, tensing the spring return system. When power is removed, the actuator returns to the normal position. The VT/VS series two-position spring return valves can be purchased with an optional built-in auxiliary SPDT end switch for interfacing or signaling; for example, zone pump burner control.

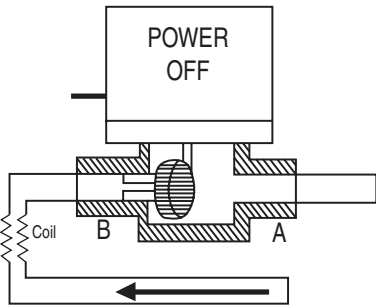

Figure 5 Two-Way Valve with Normally Closed Actuator.

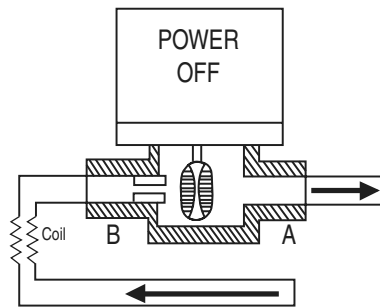

Figure 6 Two-Way Valve with Normally Open Actuator.

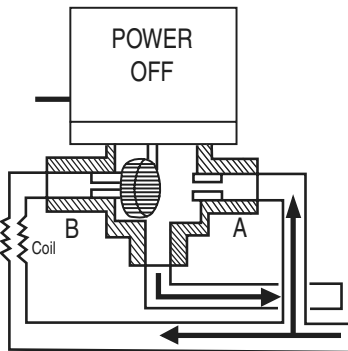

Figure 7 Three-Way Valve in Mixing Configuration Normally Closed to the Coil.

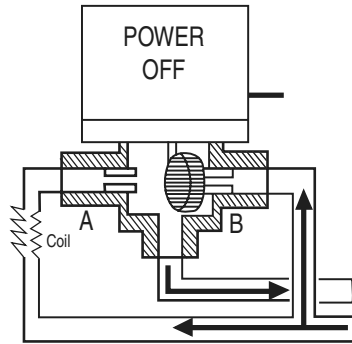

Figure 8 Three-Way Valve in Mixing Configuration Normally Open to the Coil.

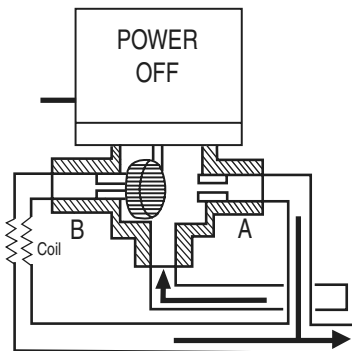

Figure 9 Three-Way Valve in Diverting Configuration Normally Closed to the Coil.

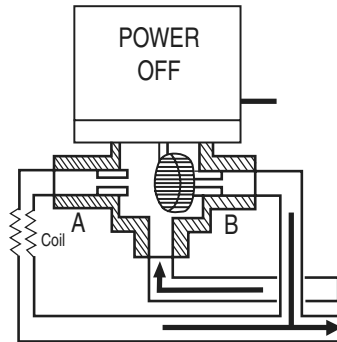

Figure 10 Three-Way Valve in Diverting Configuration Normally Open to the Coil.

Ball Valves and Actuators

The **SpaceLogic** Ball Valve and Actuator Program gives users the freedom and flexibility to easily optimize and precisely control a wide variety of applications in demanding environments.

Designed to be interchangeable and easily configured in the field, SpaceLogic Ball Valves and Actuators deliver the best of both worlds for a solution that speaks to your needs. The motorized control ball valves ensure stable, accurate floating and proportional control with a unique, low-force valve design and a compact actuator. This powerful duo offers the easiest installation and configuration.



Overview VBB/VBS Valves with M2/M3 Actuators

Application

The VBB and VBS Series Valves with SmartX Actuators are 2-way or 3-way, 1/2" or 3/4", characterized ball valves. The M3 and M2 SmartX Actuators are direct coupled to the VBB/VBS Series valves and accept two-position, floating or proportional control signals from a DDC system, controller, or thermostat for control of hot or chilled water, or solutions of up to 60% glycol. Typical applications include VAV reheat, fan coil units, hot and chilled water coils in the air handling units, heat pumps and unit ventilators.

Features

- Easy product selection – all actuators fit all valve bodies
- Fast, easy actuator installation – no linkage or tool required
- Flow characterizing insert provides equal percentage flow characteristic for stable, accurate floating and proportional control.
- ANSI IV seat leakage (0.01%) for both 2-way and 3-way valves (A and B port)
- Brass and stainless steel trim models
- Cvs from 0.3 – 10
- Normally open, normally closed, and non-spring return assemblies available
- Two-position, floating or proportional (0 – 5 VCD, 0 – 10 Vdc, 5 – 10 Vdc, or 4 – 20 mA dc)
- Proportional actuator is direct or reverse acting
- RoHS Compliant (VBS Assemblies)
- Reach compliant

Applicable Literature

- VBB and VBS Series Two-position Spring-Return Ball Valves installation instructions, F-27392
- VBB and VBS Series Floating Spring Return and Non-spring Return Ball Valves installation instructions, F-27393
- VBB and VBS Series Proportional Spring Return and Non-spring Return Ball Valves installation instructions, F-27394
- VBB and VBS Series Brochure, F-27681
- EN-205 Water System Guidelines, F-26080
- EN-206 Guidelines for Powering Multiple Actuators, F-26363



Ordering VBB/VBS Ball Valve Assemblies

Specify nine part number fields to determine the Valve Actuator Assembly part number.

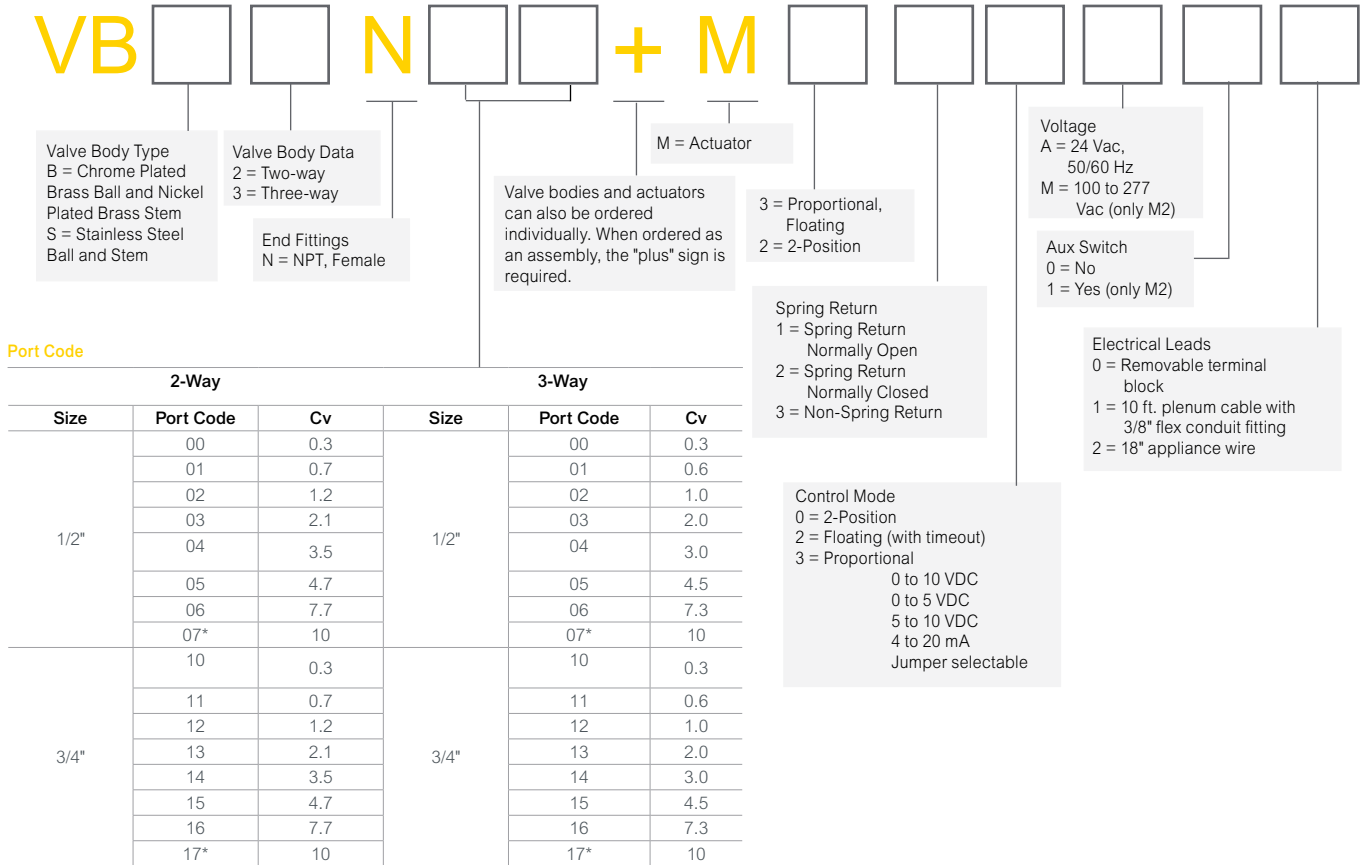

* full port

M2/M3 Actuator/Valve Specifications

Application Schematics

Typical applications

For simplicity, balancing valves and control devices are not shown.

Specifications	
Actuator	
Supply Voltage	24 Vac for floating and proportional 100–277 Vac for two position multi-voltage types
Power Requirements	See Table-1, Table-2, and Table-3.
Control Signal	2-Position, Floating, or Proportional; half wave rectified power supply
Timing, Full Open to Full Close	See Table-1, Table-2 and Table-3.
Manual Operating Lever / Position Indicator	Standard on all models.
Auxiliary End Switch (optional)	SPST 24 Vac/Vdc, 101 mA–5 A max.
Materials	Thermoplastic base and cover. Approved for use in air plenums.
Shipping & Storage Temperature Limit	–40–169°F (-40–76°C).
Operating Temperature Limit at max fluid temp.	
Floating	32–140°F (0–60°C)
Proportional	32–140°F (0–60°C)
Two-Position	32–169°F (0–76°C)
Humidity	5–95% relative humidity, non-condensing.
Locations	NEMA 2, IEC IP31. Indoor Use Only.
Valve	
Service ^a	Hot and chilled water, up–60% glycol.
System Static Pressure Limit	600 psi (4137 kPa).
Fluid Temperature Limit	20–250°F (-7–121°C).
Cv (Kv)	See Tables 4 through 7.
Close-off Pressure ^b	30 psi 2-Way; 70 psi 3-Way
Differential Pressure	30 psi normal operation 20 psi quiet operation.
Seat Material	PTFE
Characterized Insert	Glass-filled PEEK
Seat Leakage	ANSI class IV (0.01%) at both A and B ports with pressure at inlet.
End Connections	NPT threaded (VBxxNxx)
Rangeability	Greater than 300:1.
Body Material	Forged brass.
Stem Material	Stainless steel anti-blow out stem with dual Viton™ o-rings.
Ball Material	Chrome plated brass (VBB series) or stainless steel (VBS series).

a. Not rated for steam service.

b. Close-off is defined as the maximum allowable pressure drop to which a valve may be subjected while fully closed.

Agency listings	
Supply Voltage	24 Vac for floating and proportional 100–277 Vac for two position multi-voltage types
Power Requirements	See Table-1, Table-2, and Table-3.
Control Signal	2-Position, Floating, or Proportional; half wave rectified power supply
Timing, Full Open to Full Close	See Table-1, Table-2 and Table-3.
Manual Operating Lever / Position Indicator	Standard on all models.
Auxiliary End Switch (optional)	SPST 24 Vac/Vdc, 101 mA–5 A max.
Materials	Thermoplastic base and cover. Approved for use in air plenums.
Shipping & Storage Temperature Limit	–40–169°F (-40–76°C).
Operating Temperature Limit at max fluid temp.	
Floating	32–140°F (0–60°C)
Proportional	32–140°F (0–60°C)
Two-Position	32–169°F (0–76°C)
Humidity	5–95% relative humidity, non-condensing.
Locations	NEMA 2, IEC IP31. Indoor Use Only.

M2/M3 Two-position, Floating, and Proportional Actuators

Product Selection: Actuators

Table-1: Two-Position Actuators

Part Number	Control Signal	Power Loss Action (Valve Normal Position)	VA / Voltage	Leads	Stroke Timing	Spring Return Timing	End Switch
M210A00	Two- Position	Normally Open	3.5/1.8 at 24 Vac/24 Vdc	Removeable Terminal Block ^b	50 sec	35 sec.	
M210A01				10 ft. (3.05 m) Plenum Cable ^c			SPST
M210A11				18 in. (45 cm) Appliance Wire			
M210A02							
M210A12							
M210M02							
M210M12		Normally Closed	6.0/6.0 at 100–277 Vac, 50/60 Hz	18 in. (45 cm) Appliance Wire			SPST
M220A00				Removeable Terminal Block ^b			
M220A01				10 ft. (3.05 m) Plenum Cable ^c			SPST
M220A11							
M220M02							
M220M12					6.0/6.0 at 100–277 Vac, 50/60 Hz	18 in. (45 cm) Appliance Wire	

Table-2 Floating Actuators

Part Number	Control Signal	Power Loss Action (Valve Normal Position)	VA @ 24 Vac 50/60 Hz	Leads	Stroke Time, sec. 50/60 Hz	Time-out Delay, sec. 50/60 Hz
M332A00	Floating	(Non-Spring Return)	2.3/2.4	Terminal Block ^b	159/135	181 Sec
M332A01				10 ft. (3.05 m) Plenum Cable ^c		
M312A00		Normally Open	3.2/3.3 ^d	Terminal Block ^b		
M312A01				10 ft. (3.05 m) Plenum Cable ^c		
M322A00				Terminal Block ^b		
M322A01				10 ft. (3.05 m) Plenum Cable ^c		
	Normally Closed					

Table-3 Proportional Actuators

Part Number	Control Signal	Power Loss Action (Valve Normal Position)	VA @ 24 Vac 50/60 Hz	Leads	Stroke Time, sec. 50/60 Hz	Time-out Delay, sec. 50/60 Hz
M333A00	Proportional ^a (Vdc : 0–5, 0–10, 2–10, 5–10, 4–20 mA ^{d(e)})	(Non-Spring Return)	2.7/2.8	Terminal Block ^b	159/135	200/166
M333A01				10 ft. (3.05 m) Plenum Cable ^c		
M313A00		Normally Open	2.7/2.8 ^d	Terminal Block ^b		
M313A01				10 ft. (3.05 m) Plenum Cable ^c		145 Sec
M323A00				Terminal Block ^b		
M323A01				10 ft. (3.05 m) Plenum Cable ^c		
		Normally Closed				

- a. Default configured for 0–10 Vdc input signal, direct acting control.
- b. All terminal block and appliance wire units accept a 1/2" conduit connector fitting (.875" diameter).
- c. All plenum cable units include an integral 3/8" conduit connector fitting.
- d. Size transformer for 10 VA per actuator.
- e. For 4–20 mA control, a separate isolated transformer must be used with each valve.
- g. Nominal.

2-Way and 3-Way Brass and Stainless Steel Trim Valves

Brass Trim Valves

Table-4. 2-Way Brass Trim Valve Bodies
End Connection: NPT

Size	Part Number	Cv (Kv)
1/2"	VBB2N00	0.3 (0.3)
	VBB2N01	0.7 (0.6)
	VBB2N02	1.2 (1.0)
	VBB2N03	2.1 (1.8)
	VBB2N04	3.5 (3.0)
	VBB2N05	4.7 (4.1)
	VBB2N06	7.7 (6.7)
	VBB2N07 ^b	10 (8.7)
3/4"	VBB2N10	0.3 (0.3)
	VBB2N11	0.7 (0.6)
	VBB2N12	1.2 (1.0)
	VBB2N13	2.1 (1.8)
	VBB2N14	3.5 (3.0)
	VBB2N15	4.7 (4.1)
	VBB2N16	7.7 (6.7)
	VBB2N17 ^b	10 (8.7)

b. Full Port Model without characterized disc.

Table-5. 3-Way Brass Trim Valve Bodies
End Connection: NPT

Size	Part Number	Cv (Kv) A Port	Cv (Kv) B Port
1/2"	VBB3N00	0.3 (0.3)	0.3 (0.3)
	VBB3N01	0.6 (0.5)	0.8 (0.7)
	VBB3N02	1.0 (.85)	0.8 (0.7)
	VBB3N03	2.0 (1.7)	1.5 (1.3)
	VBB3N04	3.0 (2.6)	1.5 (1.3)
	VBB3N05	4.5 (3.9)	2.7 (2.3)
	VBB3N06	7.3 (6.3)	4.1 (3.5)
	VBB3N07 ^b	10.0 (8.7)	4.8 (4.1)
3/4"	VBB3N10	0.3 (0.3)	0.3 (0.3)
	VBB3N11	0.6 (0.5)	0.8 (0.7)
	VBB3N12	1.0 (.85)	0.8 (0.7)
	VBB3N13	2.0 (1.7)	1.5 (1.3)
	VBB3N14	3.0 (2.6)	1.5 (1.3)
	VBB3N15	4.5 (3.9)	2.7 (2.3)
	VBB3N16	7.3 (6.3)	4.1 (3.5)
	VBB3N17 ^b	10.0 (8.7)	4.8 (4.1)

b. Full Port Model without characterized disc.

Stainless Steel Trim Valves

Table-6. 2-Way Stainless Steel Trim Valve Bodies
End Connection: NPT

Size	Part Number	Cv (Kv)
1/2"	VBS2N00	0.3 (0.3)
	VBS2N01	0.7 (0.6)
	VBS2N02	1.2 (1.0)
	VBS2N03	2.1 (1.8)
	VBS2N04	3.5 (3.0)
	VBS2N05	4.7 (4.1)
	VBS2N06	7.7 (6.7)
	VBS2N07 ^b	10 (8.7)
3/4"	VBS2N10	0.3 (0.3)
	VBS2N11	0.7 (0.6)
	VBS2N12	1.2 (1.0)
	VBS2N13	2.1 (1.8)
	VBS2N14	3.5 (3.0)
	VBS2N15	4.7 (4.1)
	VBS2N16	7.7 (6.7)
	VBS2N17 ^b	10 (8.7)

b. Full Port Model without characterized disc.

Table-7. 3-Way Stainless Steel Trim Valve Bodies
End Connection: NPT

Size	Part Number	Cv (Kv) A Port	Cv (Kv) B Port
1/2"	VBS3N00	0.3 (0.3)	0.3 (0.3)
	VBS3N01	0.6 (0.5)	0.8 (0.7)
	VBS3N02	1.0 (.85)	0.8 (0.7)
	VBS3N03	2.0 (1.7)	1.5 (1.3)
	VBS3N04	3.0 (2.6)	1.5 (1.3)
	VBS3N05	4.5 (3.9)	2.7 (2.3)
	VBS3N06	7.3 (6.3)	4.1 (3.5)
	VBS3N07 ^b	10.0 (8.7)	4.8 (4.1)
3/4"	VBS3N10	0.3 (0.3)	0.3 (0.3)
	VBS3N11	0.6 (0.5)	0.8 (0.7)
	VBS3N12	1.0 (.85)	0.8 (0.7)
	VBS3N13	2.0 (1.7)	1.5 (1.3)
	VBS3N14	3.0 (2.6)	1.5 (1.3)
	VBS3N15	4.5 (3.9)	2.7 (2.3)
	VBS3N16	7.3 (6.3)	4.1 (3.5)
	VBS3N17 ^b	10.0 (8.7)	4.8 (4.1)

b. Full Port Model without characterized disc.

Application Note for 2-Way and 3-Way Valves

VBB/VBS Series Ball Valves are Characterized Control Ball Valves designed so that flow through the A-port exhibits equal percentage flow, thus the A-port is the control port. In a 3-way valve, the B-port is the bypass port and flow through the B-port is designed to be less than that of the A-port. In most applications, this reduced flow compensates for the pressure drop seen by the coil supplied by the A-port.

VB-2000 Series Ball Valves with SmartX Actuators

Product description

The Schneider Electric VA, VF, and VS-2xx3-xxx-9-xx series Ball Valve Assemblies are complete actuator/valve assemblies that accept Two-position, floating, or proportional control signals from a DDC system or a thermostat, for control of hot or chilled water, or solutions of up to 50% glycol. They consist of direct-coupled SmartX Spring Return or Non-Spring Return Actuators mounted on 2-way (1/2" to 3") and 3-way (1/2" to 2") ball valve bodies. Typical applications include reheat on VAV boxes, fan coil units, hot and chilled water coils in air handling units, and unit ventilators.

Applicable literature

For installation details and considerations, refer to the full Selection Guide F-27086, Ball Valve Assemblies with SmartX Actuators.

- MA40-704x, MA4x-707x, MA4x-715x Installation F-26642
- MF4x-7xx3, MF4x-7xx3-50x Installation F-26644
- MS4x-7xx3, MS4x-7xx3-50x Installation F-26645
- MF41-6043, MF41-6083 Installation F-27213
- MA4D-xxxx, MF4D-xxxx, MS4D-xxxx Installation F-27170
- MS41-6043, MS41-6083 Installation F-27214
- Mx40-704x Mounting and Wiring Instructions F-27003
- Mx41-6043 Data Sheet F-26737
- Vx-2xx3-5xx-9-xx, VB-2xx3-500-9-xx F-27087
- EN205 Water and Steam System F-26080

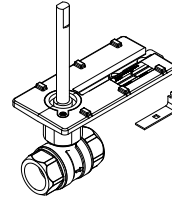

VB-2253-500-9-xx
Body/Linkage Assembly
with 2-Way Ball Valve

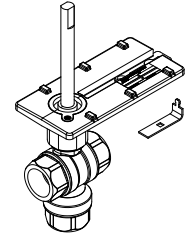

VB-2313-500-9-xx
Body/Linkage Assembly
with 3-Way Ball Valve

Ball Valve Body/Linkage Assemblies allow field mounting of SmartX Actuators.

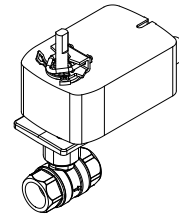

Vx-22x3-5xx-9-xx
2-Way Assembly with
Spring Return Actuator

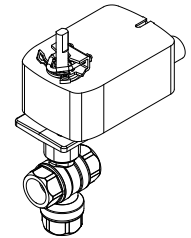

Vx-2313-5xx-9-xx
3-Way Assembly with
Spring Return Actuator

Vx-2xx3-5xx-9-xx Series Ball Valve Assemblies are available with either spring return or non-spring return SmartX Actuators.

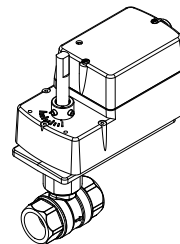

Vx-22x3-8xx-9-xx
2-Way Assembly with
Mx4D Series Actuator

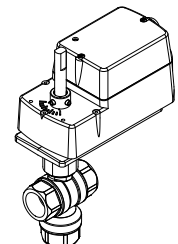

Vx-2313-8xx-9-xx
3-Way Assembly with
Mx4D Series Actuator

Vx-2xx3-8xx-9-xx Spring Return Valve Assemblies equipped with Mx4D-x0x3 SmartX Actuators, respectively.

Features & Benefits, and Ball Valve Assembly selection

Ball Valve Assembly Selection Procedure

When selecting a ball valve assembly, you must determine the applicable codes for the control signal type, valve body configuration, end connection, port size, and actuator. Select a ball valve assembly part number as follows:

1. Control Signal Type, Valve Body Configuration, and End Connection
Refer to Ball Valve Assemblies and select the appropriate codes for these part number fields.
2. Valve size (Flow Coefficient)
If the required flow coefficient (Cv) has not yet been determined, do so as follows:
 - a. Refer to Sizing and Selection to calculate the required Cv.
 - b. Select the nearest available Cv and corresponding valve body port code.
3. Actuator
Select the appropriate actuator and code according to Ball Valve Assemblies, based on the Control signal type, required valve normal position, and voltage requirements. For detailed actuator information, refer to the applicable actuator specifications.
NOTE: If an actuator with Auxiliary switch(es) is required, you may field-assemble a ball valve assembly using a ball valve body/linkage assembly (VB-2513-500-9-xx). For information on switch-equipped actuators, refer to actuator specifications.
4. Close-off Pressure
Confirm that the selected actuator and valve body combination provides sufficient close-off pressure. If no close-off pressure is shown, the valve body/actuator combination is not valid.
5. Available Space
Check the appropriate dimensional figure (Figure 1 through Figure 6 on pages 60 to 65) and its accompanying data table for dimension details.

Feature	Benefit
Close-offs of 40 to 130 psi.	Accommodates most close-off requirements.
Available in full range of line sizes, 1/2" to 3" for 2-way valves and 1/2" to 2" for 3-way valves.	Satisfies a wide range of applications.
Cvs from 0.33 to 266.	Permits optimal valve sizing, minimizing the need for pipe reducers.
Flow characterizing insert, made of glass-filled Noryl™.	Provides equal percentage flow characteristic so that the heat output of the coil is linear with respect to valve position.
Available in both spring return and non-spring return models.	Allows power loss mode requirement to be met for any given application.
Utilizes SmartX Actuators with two-position, floating, and proportional control.	Models to fit a wide range of applications.
All VB-2000 models equipped with pigtail leads.	Eases installation. Reduced electrician costs.
Low-friction seals and o-rings.	Allows the use of lower-torque actuators, reducing cost.
Valve body made of forged brass ASTM B283-06.	Rated for static pressure of 360 psi at Fluid temperatures of 20 to 250 °F (-7 to 121 °C).
ANSI Class IV (0.01% of Cv) shutoff with 2-way valves.	Allows accurate control, saves energy.
Choices of spring return direction.	Provides Normally Closed or Normally Open spring return.
Thermally isolated mounting plate.	Protects the actuator from excess cold or heat from chilled or hot water passing through the valve. Discourages condensation.
Ball Valve Body/Linkage Assemblies are available separately. They include anti-rotation clips for SmartX Actuators.	Increases flexibility and minimizes inventory.

VB-2000 Series Actuator Part Numbering

Specify five part number fields to determine the Valve Actuator Assembly part number.

SmartX 5xx Actuators

V x - 2 x x 3 - 5 x x - 9 - x x

Control Signal Type
A = Two Position
F = Floating
S = Proportional
B = Valve Body & Linkage^a (less actuator)

Configuration
2 = 2-Way
3 = 3-Way

Material
1 = Nickel/Chromium Plated Brass ⁴
5 = Stainless Steel ³

Connection
3 = Threaded NPT

Port Code
Refer to separate Port Code table

Actuator Code ¹ ²				Valves Used On ³ ⁴					
Model	Code	Normal Position	Voltage	1/2 to 1"		1-1/4"		1-1/2" to 3"	1-1/2" to 2"
				2-way	3-way	2-way	3-Way	2-Way	3-way
Two-Position									
MA40-7040	522	SR Close	120 Vac	X	X	X	X	X	X
MA40-7040	532	SR Open	120 Vac	X	X	X	X	X	X
MA40-7043	526	SR Close	24 Vac	X	X	X	X	X	X
MA40-7043-501	527	SR Close	24 Vac	X	X	X	X	X	X
MA40-7043	536	SR Open	24 Vac	X	X	X	X	X	X
MA40-7043-501	537	SR Open	24 Vac	X	X	X	X	X	X
Floating									
MF41-6043	505	NSR	24 Vac	X	X	X	X	—	—
MF41-6083	506	NSR	24 Vac	—	—	—	—	X	X
MF40-7043	526	SR Close	24 Vac	X	X	X	X	X	X
MF40-7043-501	527	SR Close	24 Vac	X	X	X	X	X	X
MF40-7043	536	SR Open	24 Vac	X	X	X	X	X	X
MF40-7043-501	537	SR Open	24 Vac	X	X	X	X	X	X
Proportional									
MS41-6043	505	NSR	24 Vac	X	X	X	X	—	—
MS41-6083	506	NSR	24 Vac	—	—	—	—	X	X
MS40-7043	526	SR Close	24 Vac	X	X	X	X	X	X
MS40-7043-501	527	SR Close	24 Vac	X	X	X	X	X	X
MS40-7043	536	SR Open	24 Vac	X	X	X	X	X	X
MS40-7043-501	537	SR Open	24 Vac	X	X	X	X	X	X
Valve Body/Linkage Assembly^a				VB-22x3-500-9-xx, VB-2313-500-9-xx					

SR = Spring Return
NSR = Non-Spring Return

^a Includes valve body, linkage, and anti-rotation clips for spring return and non-spring return SmartX actuators, listed above. Ordered separately.

Note: Not all model configurations are available as factory assemblies. You can purchase the the actuator and a VB-22x3-500-9-xx valve body and linkage separately for field assembly. '527' and '537' come with 1-SPDT auxiliary switch.

SmartX 8xx Actuators

V x - 2 x x 3 - 8 x x - 9 - x x

Control Signal Type
A = Two Position
F = Floating
S = Proportional
B = Valve Body & Linkage^a (less actuator)

Configuration
2 = 2-Way
3 = 3-Way

Material
1 = Nickel/Chromium Plated Brass ⁴
5 = Stainless Steel ³

Connection
3 = Threaded NPT

Port Code
Refer to separate Port Code table

Actuator Code ¹				Valves Used On ³ ⁴					
Model	Code	Normal Position	Voltage	Type	1/2" to 1"		1-1/4" to 3"	1-1/4" to 2"	
					2-way	3-way	2-way	3-way	
Two-Position									
MA4D-7030 ^a	815	SR Open	120 Vac	—	X	X	—	—	
MA4D-8030 ^a	817	SR Closed	120 Vac	—	X	X	—	—	
MA4D-7033-100	821	SR Open	24 Vac	—	X	X	—	—	
MA4D-8033-100	831	SR Closed	24 Vac	—	X	X	—	—	
Floating									
MF4D-7033-100	821	SR Open	24 Vac	—	X	X	—	—	
MF4D-8033-100	831	SR Closed	24 Vac	—	X	X	—	—	
Proportional									
MS4D-7033-100	821	SR Open	24 Vac	2-10 Vdc	X	X	—	—	
MS4D-7033-150	N/A ^b	SR Open	24 Vac	0-10 Vdc	X	X	—	—	
MS4D-7033-160	N/A ^b	SR Open	24 Vac	4-20 mA	X	X	—	—	
MS4D-8033-100	831	SR Closed	24 Vac	2-10 Vdc	X	X	—	—	
MS4D-8033-150	N/A ^b	SR Closed	24 Vac	0-10 Vdc	X	X	—	—	
MS4D-8033-160	N/A ^b	SR Closed	24 Vac	4-20 mA	X	X	—	—	
Valve Body/Linkage Assembly^c				VB-22x3-500-9-xx, VB-2313-500-9-xx					

SR = Spring Return NSR = Non-Spring Return

a - models have appliance cables. "1x0" models have plenum cables.
b - Factory assemblies not available. Purchase actuator and valve body separately and field assemble.
c - Includes valve body, linkage, and anti-rotation clips for spring return and non-spring return SmartX actuators, listed above. Ordered separately.

VB-2000 Series 2-Way and 3-Way Sizes, Port Codes, Cv/Kvs

Port codes

2-Way Ball Valve Assemblies with sizes, port codes, and Cvs.

Size in.	2-Way		
	Port code	Cva	Kvsa
1/2	01	0.38	0.33
	02	0.68	0.59
	03	1.3	1.1
	04	2.6	2.2
	05	4.7	4.1
	06	8.0	6.9
	07	11.7 ^b	10.1
3/4	11	0.31	0.27
	12	0.63	0.54
	13	1.2	1.0
	14	2.5	2.2
	15	4.3	3.7
	16	10.1	8.7
	17	14.7 ^b	12.7
	18	28.6 ^b	24.7
1	21	4.4	3.8
	22	9.0	7.8
	23	15.3	13.2
	24	26.1	22.6
	25	28.4 ^b	24.6
	26	43.9 ^b	38.0
	27	54.2 ^b	46.9
	1 1/4	41	4.4
42		8.3	7.2
43		14.9	12.9
44		36.5	31.6
45		41.1 ^b	35.6
46		102.3 ^b	88.5
1 1/2	51	22.8	19.7
	52	41.3	35.7
	53	73.9 ^b	63.9
	54	171.7 ^b	148.5
2	61	41.7	36.1
	63	71.1	61.5
	65	108 ^b	93.4
	66	210	181.7
	67	266 ^b	230.1
	2 1/2	71	45
72		55	47.6
73		72.3	62.5
74		101	87.4
75		162	140.1
76		202 ^b	174.7
3	82	63	54.5
	85	145 ^b	125.4

a - $Cv = \frac{gpm}{\sqrt{\Delta P}}$ (where DP is measured in psi) $kvs = \frac{Cv}{1.156}$

$kvs = \frac{m^3/h}{\sqrt{\Delta P}}$ (where DP is measured in bar; 1 bar = 100 kPa)

b - Denotes a full port valve, without the characterized insert.

3-Way Ball Valve Assemblies - sizes, port codes, and Cvs

Size in.	3-Way		
	Port code	A port Cva b	Kvsa
1/2	01	0.33	0.28
	02	0.59	0.51
	03	1	0.86
	04	2.4	2.1
	05	4.3	3.7
	06	8.0 ^c	6.9
3/4	11	0.40	0.35
	12	0.66	0.57
	13	1.3	1.1
	14	2.4	2.1
	15	3.8	3.3
	16	11 ^c	9.5
1	21	0.40	0.35
	22	0.65	0.56
	23	1.3	1.1
	24	2.3	2.0
	25	3.5	3.0
	26	4.5	3.9
	27	8.6	7.4
	28	10	8.6
	29	14.9	12.9
	30	22.3 ^c	19.3
1 1/4	41	4.1	3.5
	43	8.7	7.5
	44	12.7	11.0
	45	19.4 ^c	16.8
	46	34.1 ^c	29.5
	1 1/2	51	4
52		8.3	7.2
53		13.4	11.6
54		23.5	20.3
55		32 ^c	27.7
56		61.1 ^c	52.8
2	61	23.9	20.7
	62	38.2	33.0
	63	56.7 ^c	49.0
	64	108.5 ^c	93.8

a - $Cv = \frac{gpm}{\sqrt{\Delta P}}$ (where DP is measured in psi) $kvs = \frac{Cv}{1.156}$

$kvs = \frac{m^3/h}{\sqrt{\Delta P}}$ (where DP is measured in bar; 1 bar = 100 kPa)

b - B port Cv is 80% of A port Cv.

c - Denotes a full port valve, without the characterized insert.

VB-2000 Series 2- and 3-Way Ball Valve Specifications

Ball Valve specifications

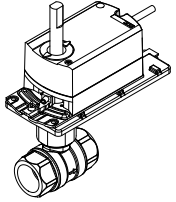
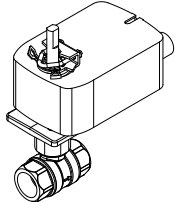
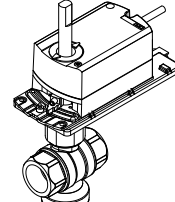
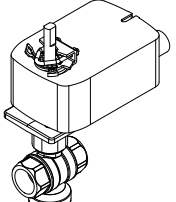
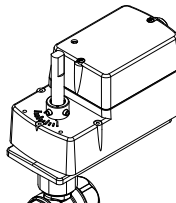
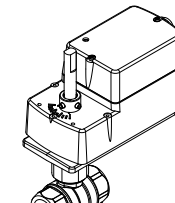
Valve assembly series		2-Way		3-Way	
Ball Valve Assemblies using SmartX Actuators					
	Non-Spring Return Vx-22x3-505-9-P Vx-22x3-506-9-P	Spring Return Vx-22x3-5xx-9-P	Non-Spring Return Vx-2313-505-9-P Vx-2313-506-9-P	Spring Return Vx-2313-5xx-9-P	
		Spring Return VA-22x3-81x-9-P Vx-22x3-82x-9-P Vx-22x3-83x-9-P		Spring Return VA-2313-81x-9-P Vx-2313-82x-9-P Vx-2313-83x-9-P	
Applications	Chilled or hot water, up to 50% Glycol Solution				
Type of end fitting	NPT Screwed				
Size	1/2" through 3"		1/2" through 2"		
Valve assembly series	Vx-22x3-xxx-9-P		Vx-2313-xxx-9-P		
Flow type	Equal Percentage				
Material	Forged Brass (ASTM B283-06)				
Body	Forged Brass (ASTM B283-06)				
Ball	1 = Nickel/Chromium-Plated Brass 5 = Stainless Steel		Nickel/Chromium-Plated Brass		
Characterizing insert	Glass-filled Noryl				
Stem	Stainless Steel				
Ball seals	Reinforced Teflon® Seals with EPDM O-Rings				
Stem seals	EPDM O-Rings				
Mounting plate	Glass-filled Polymer				
Maximum static pressure	360 psig (25 bar) at 250 °F (121 °C)				
Maximum operating differential pressure	Same as close-off pressures shown in Table-4 or Table-6. Refer to "Cavitation Limitations on Valve Pressure Drop" on page 85				
Seat leakage	ANSI Class IV (0.01% of Cv)		ANSI Class IV (0.01% of Cv), piped coil-side outlet to A only		
Fluid (water) temp.	Minimum	20°F (-7°C)			
	Maximum	250°F (121°C)			

VB-2000 2-Way Ball Valve Assemblies with SmartX Actuators

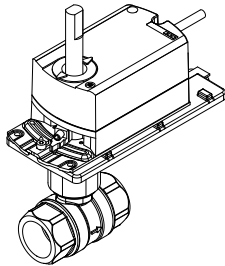

Vx-22x3-505-9-P

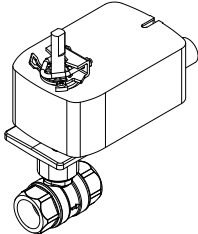

Vx-22x3-5xx-9-P

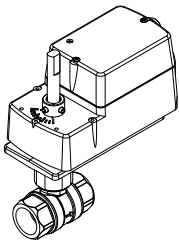

Spring Return
VA-22x3-81x-9-P
Vx-22x3-82x-9-P
Vx-22x3-83x-9-P

Non-Spring Return

Spring Return

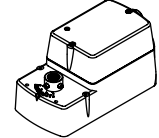
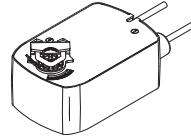
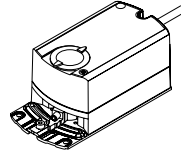

Actuator models (Actuator codes)

24 Vac			
Floating MF41-6043 (505)	Floating MF41-6083 (506)	Two-position MA40-7043 (N.C.) (526) MA40-7043 (N.O.) (536) MA40-7043-501	Two-position MA4D-7033-100 (N.O.) (821) MA4D-8033-100 (N.C.) (831)
Proportional MS41-6043 (505)	Proportional MS41-6083 (506)	Floating MF40-7043 (N.C.) (526) MF40-7043 (N.O.) (536) MF40-7043-501	Floating MF4D-7033-100 (N.O.) (821) MF4D-8033-100 (N.C.) (831)
		Proportional MS40-7043 (N.C.) (526) MS40-7043 (N.O.) (536) MS40-7043-501 MS40-7043-MP MS40-7043-MP5	Proportional MS4D-7033-100 (N.O.) (821) MS4D-7033-150 MS4D-7033-160 MS4D-8033-100 (N.C.) (831) MS4D-8033-150 MS4D-8033-160
120 Vac			
		Two-position MA40-7040 (N.C.) (522) MA40-7040 (N.O.) (532) MA40-7040-501	Two-position MA4D-7030 (N.O.) (815) MA4D-8030 (N.C.) (817)
230 Vac			
		MA40-7041 MA40-7041-501	

Valve assembly part number	Size (in.)	P code ^b	Close-off pressure, psi (kPa)		
Ball Valve Assembly With SmartX Vx-22x3-5xx-9-Pc Valve/Linkage Assembly VB-2253-500-9-P	½	1, 2, 3, 4, 5, 6, 7	130 (896) (field assemble)	-	130 (896) (field assemble)
	¾	11, 12, 13, 14, 15, 16, 17, 18			
	1	21, 22, 23, 24, 25, 26, 27	100 (689)		100 (689)
	1¼	41, 42, 43, 44, 45, 46	70 (482)		
	1½	51, 52, 53, 54		70 (482)	-
	2	61, 63, 65, 66, 67			
	2½	71, 72, 73, 74, 75, 76			
	3	82, 85			

a - For non-spring return, 2-way ball valve assemblies are shipped NO (normally open).

b - To find the corresponding flow coefficients for these port codes, refer to "VB-2000 Series Actuator Part Numbering" on page 52.

c - To determine a specific part number, identify the actuator's Control signal type ("A," "F," or "S"), Actuator code, and P code. Refer to "VB-2000 3-Way Assemblies with SmartX Actuators" on page 56.

VB-2000 3-Way Assemblies with SmartX Actuators

Note: Not all model configurations are available as factory assemblies. You can purchase the actuator and a VB-2253-500-9-xx valve body and linkage separately for field assembly. All valve sizes - ANSI Class IV (0.01% of CK) shut-off piped coil-side outlet to A.

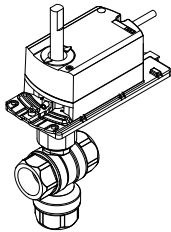

Vx-2313-505-9-P
Vx-2313-506-9-P

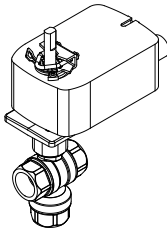

Vx-2313-5xx-9-P

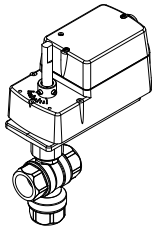

Spring Return
VA-2313-81x-9-P
Vx-2313-82x-9-P
Vx-2313-83x-9-P

Non-Spring Return

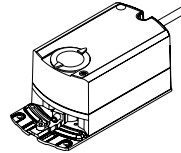

Spring Return

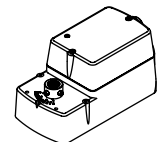
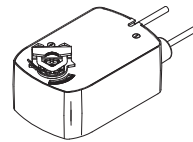

Actuator models (Actuator codes)

24 Vac			
Floating MF41-6043 (505)	Floating MF41-6083 (506)	Two-position MA40-7043 (N.C.) (526) MA40-7043 (N.O.) (536) MA40-7043-501	Two-position MA4D-7033-100 (N.O.) (821) MA4D-8033-100 (N.C.) (831)
Proportional MS41-6043 (505)	Proportional MS41-6083 (506)	Floating MF40-7043 (N.C.) (526) MF40-7043 (N.O.) (536) MF40-7043-501	Floating MF4D-7033-100 (N.O.) (821) MF4D-8033-100 (N.C.) (831)
		Proportional MS40-7043 (N.C.) (526) MS40-7043 (N.O.) (536) MS40-7043-501 MS40-7043-MP MS40-7043-MP5	Proportional MS4D-7033-100 (N.O.) (821) MS4D-7033-150 MS4D-7033-160 MS4D-8033-100 (N.C.) (831) MS4D-8033-150 MS4D-8033-160
120 Vac			
		Two-position MA40-7040 (N.C.) (522) MA40-7040 (N.O.) (532) MA40-7040-501	Two-position MA4D-7030 (N.O.) (815) MA4D-8030 (N.C.) (817)
		230 Vac MA40-7041 MA40-7041-501	

Valve assembly part number	Size (in.)	P code	Close-off pressure, psi (kPa)		
Ball Valve Assembly with SmartX VX-2313-5xx 9-P Valve/Linkage Assembly VB-2313-500-9-P	½	1, 2, 3, 4, 5, 6,	50(344) (field assemble)	-	50 (344) (field assemble)
	¾	11, 12, 13, 14, 15, 16			
	1	21, 22, 23, 24, 25, 26, 27, 28, 29, 30, 31	50 (344)		
	1¼	41, 42, 43, 44, 45, 46	40 (275)		
	1½	51, 52, 53, 54	-	40 (275)	
	2	61, 62, 63, 64			

a - Non-spring return, 3-way ball valve assemblies are shipped open A to AB and a control voltage increase will close A to AB and open B to AB

b - Spring return 3-way valves are normally closed, A to AB and a control voltage increase will close A to AB and open B to AB.

c - To find the corresponding flow coefficients for these port codes, refer to "3-way Ball Valve Assemblies with Sizes, Port Codes and CVS."

d - To determine a specific part number, identify the actuator's Control Signal Type ("A," "F," or "S"), Actuator code, and P code.

VB-2000 SR and NSR SmartX Actuator Specifications

Specifications	
MF/MS41-6043/83 NSR SmartX Actuators	
Inputs	Control Signal Floating three-position control, 24 Vac Proportional, 0–10 Vdc; input
Power Requirements (see table)	
Connections	All 24 Vac circuits are Class 2 3 ft. (0.9 m) long, 18 AWG plenum rated leads
Motor Type	Synchronous
Outputs	
Electrical	
Position feedback voltage for MS41-6043/6083	0–10 Vdc, 1 mA
Timing: 90°	
Timing in Sec.	At 60 Hz At 50 Hz
MF41-6043 and MS41-6043	90 108
MF41-6043 and MS41-6083	125 150
Outputs	44 lb-in. (5 N-m) for Mx41-6043 88 lb-in. (10 N-m) for Mx41-6083
Electrical	
Output torque rating	Normal angle of rotation is 90 limited to a maximum of 95
Stroke	Field adjustable to limit travel on either end of stroke
Position indicator	Adjustable pointer is provided for position indication.
Output shaft setscrew	
Tightening torque	50–60 lb-in. (6.3–6.8 N-m)
Environmental	
Temperature limits	
Shipping and storage	-40–70C (-40–158F) ambient
Operating	-32–55C (-25–130F) ambient
Note: Check the valve operating temperature limit. The minimum valve media temperature limit	
-7 C (20 F)	5–95%, RH, non-condensing
Humidity	
Enclosure rating	IEC IP54 (NEMA Type 3)
Agency Listings (Actuator)	
UL	UL-873, Underwriters Laboratories
cUL	Canadian Standards C22.2 No. 24-83
European Community	EMC Directive (89/336/EEC) Emissions (EN50081-1) Immunity (EN50081-2)

Part Number	Power input @ 50/60 Hz			
	Voltage	Running VA	Holding VA	Watts
MF41-6043 and MF41-6083	24 Vac – 20/-15%	2.3	–	2.0
M41-6043 and MS41-6083		3.3	1.2	3.0

Specifications	
Mx40-704x SR SmartX Actuators	
Inputs	ON/OFF SPST control contacts or Triacs (500 mA rated) Proportional 0–10 Vdc or 4–20 mA D C with 500 ohm resistor Proportional 6–9 Vdc Floating point control, 24 Vac
MA40-7043	
MS40-7043	
MS40-7043 MP/MP5	
MF40-7043	
Power Requirements (see table)	
Connections	All 24 Vac circuits are Class 2
MA40-704x and MA40-704x-501	
MF40-7043 and MA40-7043-501,	3 ft. (0.9 m) long, appliance cable for M20 Metric conduit use AM-756 adaptor
MS40-7043 and MS40-7043-501	
Motor Type	Brush DC Brushless DC
MA40-704x	
MF40-7043, MS40-7043	
Outputs	
Electrical	
Mx40-7043-501 and MS40-7043-501	One auxiliary switch available. SPDT 6 A resistive @ 24 Vac, adjustable 0 to 95 (0 to 1 scale). Switch meets VDE requirements for 6 (1.5) A, 24 Vac
MA40-7040-501	One auxiliary switch available. SPDT 6 A resistive @ 250 Vac, adjustable 0 to 95 (0 to 1 scale). Switch meets VDE requirements for 6 (1.5) A, 250 Vac.
Position feedback voltage	For 2–10 Vdc proportional actuators, the feedback signal is the same voltage range as the input signal. The feedback signal can supply up to 0.5 mA to operate up to four additional slave actuators (proportional (MS) models only).
Control mode	Switch provided for selection of direct acting or reverse acting control mode on proportional models
Timing	
MA40-704x	Approximately 50 sec.
MF40 and MS40-7043	Approximately 130 sec.
Auxiliary Power Supply	
MS40-7043-MP and MS40-7043	+20 Vdc @ 25mA (max.)
Position indicator	Visual scale numbered from 0–90, provided for position indication
Mechanical	
Stroke	Angle of rotation is limited to a maximum of 95, with mechanical stop
Output torque rating	35 lb-in. (4 N-m)
Mx40-704x	
Environmental	
Temperature limits	
Shipping and storage	-40–71C (-40–160F) ambient
Operating	-30–60C (-22–140F) ambient
Note: Check the valve operating temperature limit. The minimum valve media temperature limit -7 C (20 F)	
Humidity	5–95%, RH, non-condensing
Enclosure rating	IEC IP54 (NEMA 2, UL Type 2)
Agency Listings (Actuator)	
UL	UL-873, Underwriters Laboratories (File #9429 Category Temperature-Indicating and Regulating Equipment)
cUL	Canadian Standards C22.2 No. 24-93.
European Community	EMC Directive (89/336 EEC) Low Voltage Directive (72/23/EEC)
Australia	This product meets requirements to bear the RSM according to the terms specified by the Communications Authority under the Radio communications Act 1992

VB-2000 SR and NSR SmartX Actuator Specifications

Mx4D-7033/8033-xxx SmartX Actuators

Inputs

Control Signal and Power Requirements (see table)

a. 4 to 20 mAdc with field-installed 500 W resistor.

Connections

Mx4D-7033-1x0 and Mx4D-8033 1x0 10 ft. (3.05 m) long, plenum cable ½" (13 mm) conduit connector. For M20 Metric conduit, use AM-756 adaptor

Motor type

Brush DC

Outputs

Electrical, Timing, Approximate Timing in Sec. @ 70 °F (21 °C)

Part Number	Powered	Spring return	
		CCWb	CWb
MA4D-7033-100	56	26	–
MF4D-7033-100	85	21	–
MS4D-7033-100	85	21	–
MA4D-8033-100	56	–	26
MF4D-8033-100	85	–	21
MS4D-8033-1x0	85	–	21

Position feedback voltage: For 0–3 Vdc, 0–9 Vdc, 2–10Vdc and 0–10Vdc proportional actuators, the feedback signal is the same voltage range as the input signal. The 4–20 mA proportional actuators and floating actuators have 2–10 Vdc feedback signal. The feedback signal can supply up to 0.5 mA to operate up to four additional slave actuators.

Mechanical

Stroke 93 nominal
 Manual override Allows positioning of valve shaft, using a manual crank
 Output torque rating 30 lb-in (3.4 N-m)
 RA/DA Jumper (Proportional Models) Permits selection of reverse acting or direct acting control
 Position indicator Visual indicator

Environmental

Temperature Limits
 Shipping and storage
 Operating -40–160 °F (-40 –71 °C) ambient
 -22–140 °F (-30–60 °C) ambient

NOTE: Check the valve operating temperature limit. The minimum valve media temperature limit is 20 °F (6.7 °C)

Humidity 15 to 95% RH, non-condensing

Enclosure Rating

NEMA 1, NEMA 2, UL Type 2 (IEC IP54) with customer-supplied watertight conduit connectors. Enclosure is air plenum rated.

Agency Listings (Actuator)

UL UL 873, Underwriters Laboratories
 File #9429 Category Temperature- Indicating and Regulating Equipment Plenum rated

cUL

Canadian Standards C22.2 No. 24-93

European Community

EMC Directive (89/336/EEC) Low voltage directive (73/23/EEC). This product fits into Installation Category (Overvoltage category)

Australia

II per EN 61010-1. This product meets requirements to bear the RCM mark according to the terms specified by the Communications Authority under the Radio communications Act 1992

VB-2000 SR and NSR SmartX Actuator Specifications

Part Number	Voltage 50/60 Hz	Voltage Vdc	Running				Holding (Hz)	
			50 Hz		60 Hz		50	60
			VA	W	VA	W	W	W
MA40-7043	24 Vac ± 20%	22-30	4.4	2.9	4.4	2.9	0.8	0.8
MA40-7043-501								
MS40-7043			5.6	4.2	5.6	4.2	2.4	2.4
MS40-7043-501								
MF40-7043			5.9	4.4	5.9	4.4	2.9	2.9
MF40-7043-501								
MS40-7043-MP*			6.9	5.0	6.6	5.0	3.2	3.2
MS40-7043- MP5*								
MA40-7040*	120 Vac ± 10%	-	6.4	3.8	4.3	3.4	1.6	1.2
MA40-7040-501*								
MA40-7041	230 Vac	-	5.8	4.1	4.6	3.9	1.5	
MA40-7041-501								

Part Number	Control signal	Voltage	Actuator power input			
			Running			Holding
			50/60 Hz		DC Amps	50/60 Hz
			VA	W		W
MA4D-x033-100	2 position	24 Vac ± 20% or 20 to 30 Vdc	5.1	3.6	0.14	1.3
MF4D-x033-100	Floating		6.8	4.2		
MS4D-x033-100	2 to 10 Vdca Proportional		6.1	3.4	0.12	1.4
MS4D-x033-150	0 to 10 Vdc Proportional					
MS4D-x033-160	4 to 20 mAdc Proportional					

VB-2000 2-Way Ball Valve Assembly Dimensions (44/88 lb-in.)

2-Way Ball Valve Assembly Dimensions

Valve Assembly Part Number	Valve Size in.	P Code ^a	Valve Dimensions in inches (mm) Refer to Figure 1			
			A	B	C	D
2-Way VF-22x3-505-9-P VF-22x3-506-9-P VS-22x3-505-9-P VS-22x3-506-9-P	½	1, 2, 3, 4, 5, 7	2-3/8 (60)	7 (178)	8¼ (210)	3-1/8 (79)
		6	2-5/8 (67)	7 (178)	8½ (216)	3-3/8 (86)
	¾	11, 12, 13, 14, 15, 17	2-7/16 (62)	7 (178)	8¼ (210)	3¼ (83)
		16, 18	2¾ (70)	7 (178)	8½ (216)	3-3/8 (86)
	1	21, 23	3-1/16 (78)	7 (178)	8-7/8 (225)	3-5/8 (92)
		22, 25	2¾ (70)	7 (178)	8½ (216)	3-3/8 (86)
		24, 26	4½ (114)	7-3/8 (187)	9-3/8 (238)	3-7/8 (98)
		27	3 (76)	7 (178)	8-7/8 (225)	3-5/8 (92)
	1¼	41, 42, 43, 45	3 (76)	7 (178)	8-7/8 (225)	3-5/8 (92)
		44, 46	3-5/8 (92)	7-1/8 (181)	9-3/8 (238)	3-¾ (95)
	1½	51, 53	3-7/16 (87)	7-1/8 (181)	9-3/8 (238)	3-¾ (95)
		52, 54	4-1/16 (103)	7¼ (184)	9-7/8 (251)	4-1/16 (103)
	2	61, 65	3-15/16 (100)	7¼ (184)	9-7/8 (251)	4 (102)
		63, 66, 67	4-15/16 (125)	7-¾ (197)	10½ (267)	4-7/16 (113)
	2½	71, 72, 76, 73, 74, 75	5-3/8 (137)	8 (203)	10-¾ (273)	4½ (114)
	3	82, 85	5-11/16 (144)	8-1/8 (206)	10-11/16 (271)	4¼ (108)

a - To find the corresponding flow coefficients for these port codes, refer to "2-Way Ball Valve Assemblies with Sizes, Port Codes, and Cvs."

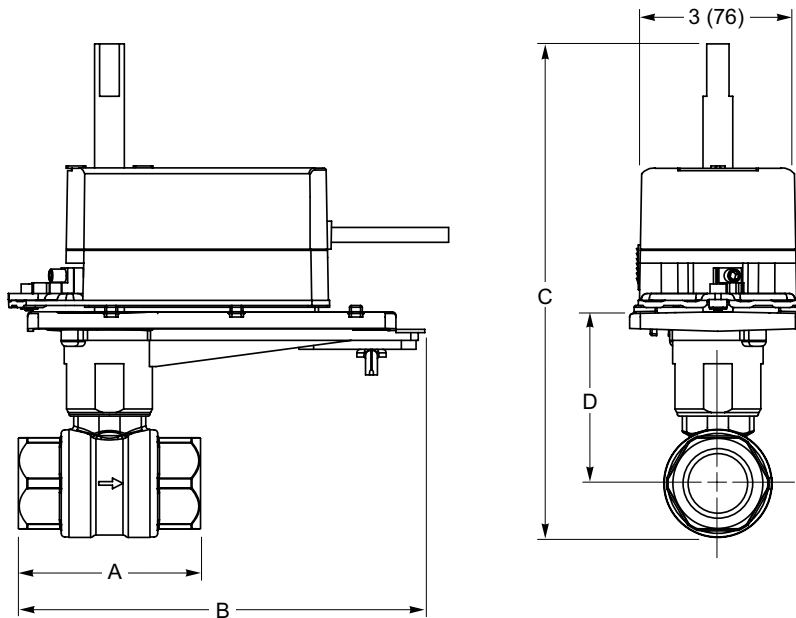

Figure 1. Mx41-6043 or Mx41-6083 with 2-Way Ball Valve.

VB-2000 3-Way Ball Valve Assembly Dimensions (44/88 lb-in.)

3-Way Ball Valve Assembly Dimensions

Valve Assembly Part Number	Valve Size in.	P Code ^a	Valve Dimensions in inches (mm) Refer to Figure 2				
			A	B	C	D	E
3-Way VF-2313-505-9-P VF-2313-506-9-P VS-2313-505-9-P VS-2313-506-9-P	½	1, 2, 3, 4, 5, 6	2-5/8 (67)	7 (178)	9-¾ (248)	3-5/16 (84)	2 (51)
	¾	11, 12, 13, 14, 15, 16	2¾ (70)	7 (178)	9-¾ (248)	¾ (83)	2 (51)
	1	21, 22, 23, 24, 25, 28	2¾ (70)	7 (178)	9-13/16 (249)	¾ (83)	2-1/8 (54)
			4¼ (108)	7-3/8 (187)	11-5/8 (295)	3-5/8 (92)	3-1/16 (78)
		26, 29, 31	4¼ (108)	7½ (191)	11½ (292)	¾ (89)	3-1/8 (79)
	1¼	45	3 (76)	7 (178)	10-5/8 (270)	3-5/8 (92)	2-3/8 (60)
		41, 43, 44, 46	3-5/8 (92)	7-1/8 (181)	10-7/8 (276)	¾ (89)	2¾ (70)
	1½	51, 52, 53, 55	3-5/8 (92)	7-1/8 (181)	10-7/8 (276)	3-5/8 (92)	2¾ (70)
		54	4 (102)	7¼ (184)	11-¾ (298)	4 (102)	¾ (83)
		56	4 (102)	7-¾ (197)	11-¾ (298)	4 (102)	¾ (83)
	2	61, 63	3-15/16 (100)	7¼ (184)	11-¾ (298)	3-7/8 (98)	3-1/16 (78)
		62, 64	4-7/8 (124)	7-¾ (197)	12-11/16 (322)	4½ (114)	3-7/8 (98)

a - To find the corresponding flow coefficients for these port codes, refer to "3-Way Ball Valve Assemblies with Sizes, Port Codes, and Cvs"

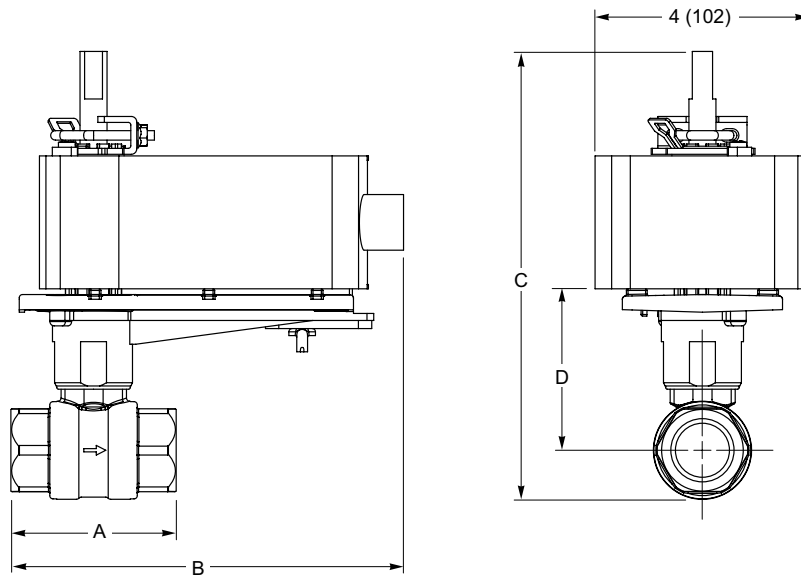

Figure 2. Mx41-6043 or Mx41-6083 with 3-Way Ball Valve.

VB-2000 2-Way Ball Valve Assembly Dimensions (35 lb-in.)

2-Way Ball Valve Assembly Dimensions

Valve Assembly Part Number	Valve Size in.	P Code ^a	Valve Dimensions in inches (mm) Refer to Figure 2					
			A	B	C	D	E	
3-Way VF-2313-505-9-P VF-2313-506-9-P VS-2313-505-9-P VS-2313-506-9-P	½	1, 2, 3, 4, 5, 6	2-5/8 (67)	7 (178)	9-¾ (248)	3-5/16 (84)	2 (51)	
	¾	11, 12, 13, 14, 15, 16	2¾ (70)	7 (178)	9-¾ (248)	¾ (83)	2 (51)	
	1	21, 22, 23, 24, 25, 28	27, 30	2¾ (70)	7 (178)	9-13/16 (249)	¾ (83)	2-1/8 (54)
			26, 29, 31	4¼ (108)	7-3/8 (187)	11-5/8 (295)	3-5/8 (92)	3-1/16 (78)
				4¼ (108)	7½ (191)	11½ (292)	¾ (89)	3-1/8 (79)
	1¼	45	3 (76)	7 (178)	10-5/8 (270)	3-5/8 (92)	2-3/8 (60)	
		41, 43, 44, 46	3-5/8 (92)	7-1/8 (181)	10-7/8 (276)	¾ (89)	2¾ (70)	
	1½	51, 52, 53, 55	3-5/8 (92)	7-1/8 (181)	10-7/8 (276)	3-5/8 (92)	2¾ (70)	
		54	4 (102)	7¼ (184)	11-¾ (298)	4 (102)	¾ (83)	
		56	4 (102)	7-¾ (197)	11-¾ (298)	4 (102)	¾ (83)	
	2	61, 63	3-15/16 (100)	7¼ (184)	11-¾ (298)	3-7/8 (98)	3-1/16 (78)	
		62, 64	4-7/8 (124)	7-¾ (197)	12-11/16 (322)	4½ (114)	3-7/8 (98)	

a - To find the corresponding flow coefficients for these port codes, refer to "3-Way Ball Valve Assemblies with Sizes, Port Codes, and Cvs" .

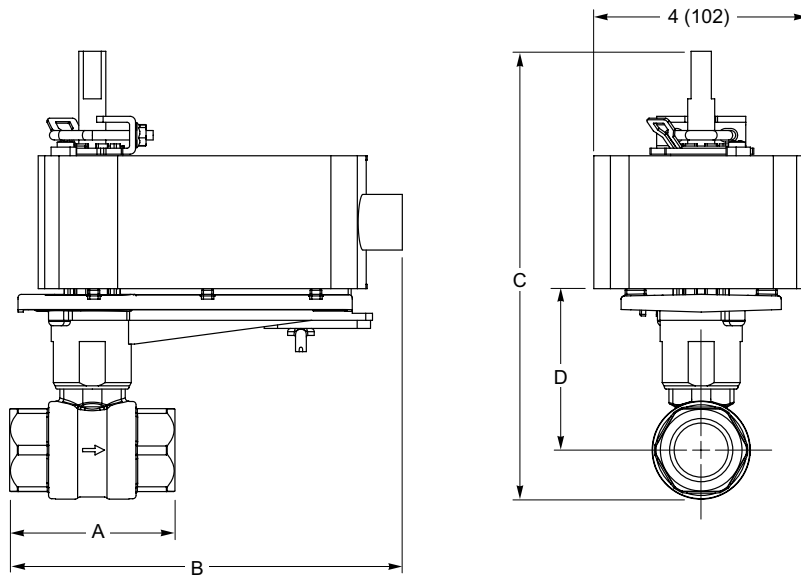

Figure 2. Mx41-6043 or Mx41-6083 with 3-Way Ball Valve.

VB-2000 3-Way Ball Valve Assembly Dimensions (35 lb-in.)

3 - Way Ball Valve Assembly Dimensions

Valve Assembly Part Number	Valve Size in.	P Code ^a	Valve Dimensions in inches (mm) Refer to Figure 4					
			A	B	C	D	E	
3-Way VA-2313-526-9-P VA-2313-536-9-P VF-2313-526-9-P VF-2313-536-9-P VS-2313-526-9-P VS-2313-536-9-P	1/2	1, 2, 3, 4, 5, 6	2-5/8 (67)	7-3/8 (187)	9-3/4 (248)	3-5/16 (84)	2 (51)	
	3/4	11, 12, 13, 14, 15, 16	2 3/4 (70)	7-3/8 (187)	9-3/4 (248)	3 1/4 (83)	2 (51)	
	1	21, 22, 23, 24, 25, 28	2 3/4 (70)	7-3/8 (187)	9-13/16 (249)	3 1/4 (83)	2-1/8 (54)	
			27, 30	4 1/4 (108)	8 (203)	11-5/8 (295)	3-5/8 (92)	3-1/16 (78)
			26, 29, 31	4 1/4 (108)	8-1/8 (206)	11 1/2 (292)	3 1/2 (89)	3-1/8 (79)
	1 1/4	45	3 (76)	7-3/8 (187)	10-5/8 (270)	3-5/8 (92)	2-3/8 (60)	
			41, 43, 44, 46	3-5/8 (92)	7-3/4 (197)	10-7/8 (276)	3 1/2 (89)	2 3/4 (70)
	1 1/2	51, 52, 53, 55	3-5/8 (92)	7-3/4 (197)	10-7/8 (276)	3-5/8 (92)	2 3/4 (70)	
			54	4 (102)	7-7/8 (200)	11-3/4 (298)	4 (102)	3 1/4 (83)
			56	4 (102)	8-3/8 (213)	11-3/4 (298)	4 (102)	3 1/4 (83)
	2	61, 63	3-15/16 (100)	7-7/8 (200)	11-3/4 (298)	3-7/8 (98)	3-1/16 (78)	
			62, 64	4-7/8 (124)	8-3/8 (213)	12-11/16 (322)	4 1/2 (114)	3-7/8 (98)

a - To find the corresponding flow coefficients for these port codes, refer to "3-Way Ball Valve Assemblies with Sizes, Port Codes, and Cvs"

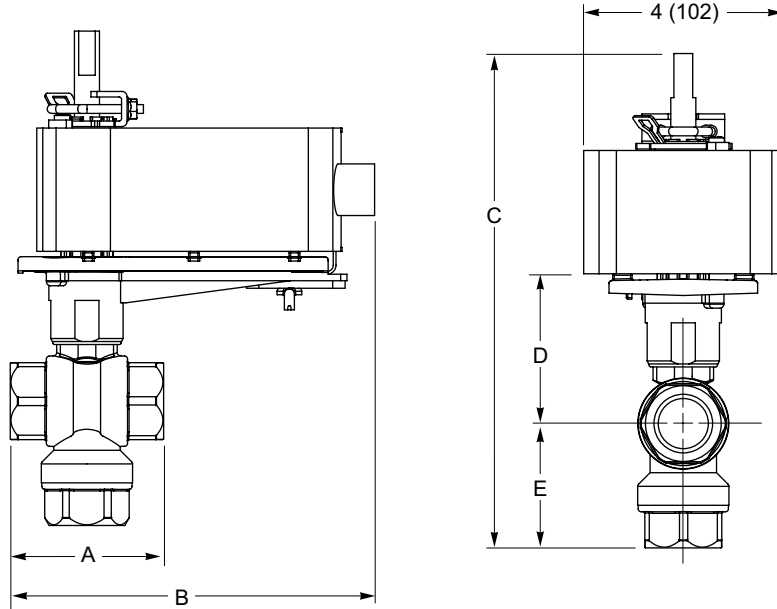

Figure 4. Mx40-704x with 3-Way Ball Valve.

VB-2000 2-Way Ball Valve Assembly Dimensions (30 lb-in.)

2-Way Ball Valve Assembly Dimensions

Valve Assembly Part Number	Valve Size in.	P Code ^a	Valve Dimensions in inches (mm) Refer to Figure 5			
			A	B	C	D
2-Way VA-22x3-815-9-P VA-22x3-817-9-P VA-22x3-821-9-P VA-22x3-831-9-P VF-22x3-821-9-P VF-22x3-831-9-P VS-22x3-821-9-P VS-22x3-831-9-P	1/2	1, 2, 3, 4, 5, 7	2-3/8 (60)	8¼ (210)	8¼ (210)	3-1/8 (79)
		6	2-5/8 (67)	8¼ (210)	8½ (216)	3-3/8 (86)
	3/4	11, 12, 13, 14, 15, 17	2-7/16 (62)	8¼ (210)	8¼ (210)	3¼ (83)
		16, 18	2¾ (70)	8¼ (210)	8½ (216)	3-3/8 (86)
	1	21, 23	3-1/16 (78)	8¼ (210)	8-7/8 (225)	3-5/8 (92)
		22, 25	2¾ (70)	8¼ (210)	8½ (216)	3-3/8 (86)
		24, 26	4½ (114)	8-7/8 (225)	9-3/8 (238)	3-7/8 (98)
		27	3 (76)	8¼ (210)	8-7/8 (225)	3-5/8 (92)

a - To find the corresponding flow coefficients for these port codes, refer to "2-Way Ball Valve Assemblies with Sizes, Port Codes, and Cvs."

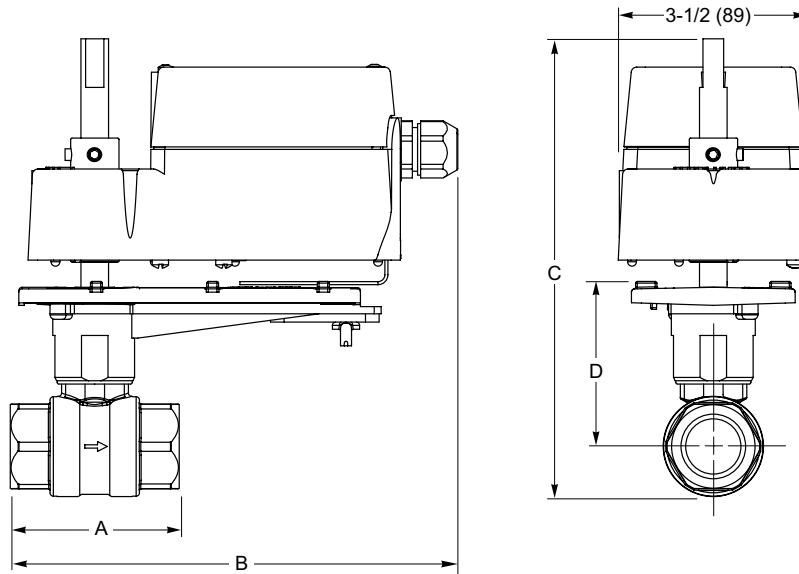

Figure 5. MA4D-7033, MF4D-7033, MS4D-7033, MA4D-8033, MF4D-8033, or MS4D-8033 with 2-Way Ball Valve.

VB-2000 3-Way Ball Valve Assembly Dimensions (30 lb-in.)

3-Way Ball Valve Assembly Dimensions

Valve Assembly Part Number	Valve Size in.	P Code ^a	Valve Dimensions in inches (mm) Refer to Figure 6				
			A	B	C	D	E
3-Way VA-2313-815-9-P VA-2313-817-9-P VA-2313-821-9-P VA-2313-831-9-P VF-2313-821-9-P VF-2313-831-9-P VS-2313-821-9-P VS-2313-831-9-P	1/2	1, 2, 3, 4, 5, 6	2-5/8 (67)	8 1/2 (216)	9-3/4 (248)	3-5/16 (84)	2 (51)
	3/4	11, 12, 13, 14, 15, 16	2 3/4 (70)	8 1/2 (216)	9-3/4 (248)	3 1/4 (83)	2 (51)
	1	21, 22, 23, 24, 25, 28	2 3/4 (70)	8 1/2 (216)	9-13/16 (249)	3 1/4 (83)	2-1/8 (54)
		27, 30	4 1/4 (108)	8-7/8 (225)	11-5/8 (295)	3-5/8 (92)	3-1/16 (78)
	26, 29, 31	4 1/4 (108)	9 (229)	11 1/2 (292)	3 1/2 (89)	3-1/8 (79)	

a - To find the corresponding flow coefficients for these port codes, refer to "3-Way Ball Valve Assemblies with Sizes, Port Codes, and Cvs" on page 4.

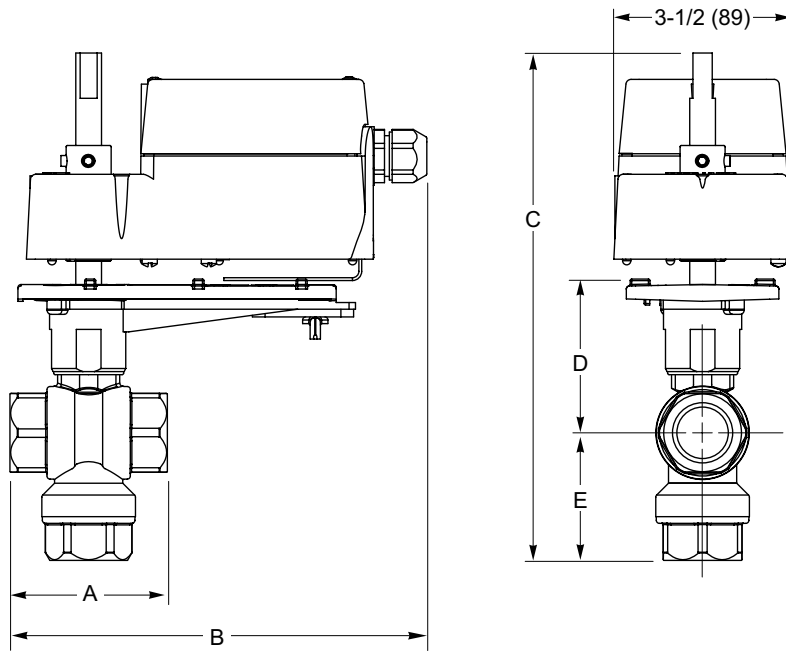

Figure 6. MA4D-7033, MF4D-7033, MS4D-7033, MA4D-8033, MF4D-8033, or MS4D-8033 with 3-Way Ball Valve.

Pressure Independent Balancing Control Valves and Actuators

Pressure Independent Balancing Control Valves provide the optimum control of fluid flow, unaffected by changes in system pressure. With inherent hydronic system balancing characteristics, PIBCV products provide the ultimate solution for the most energy efficient room temperature control.

Additional benefits of PIBCV include reducing the time taken for system balancing and commissioning.



Description and Features

The **SpaceLogic** PIBC range is a comprehensive selection of automatic balancing and control valves that provide flow limitation, with full control authority over hydronic regulation.

Automatic balancing within PIBC valves provide stable flow regulation regardless of pressure fluctuations in the system and all valves have an adjustable flow limitation set point. The control valve portion of the PIBC further regulates the water/glycol flow from close-off up to the maximum flow limit setting.

Typical applications are temperature control of chillers, air-handling units, heat exchanges and terminal units such as fan coils, induction units and radiant panels.

Features

- Reduced Energy Consumption
 - Pressure independence ensures no overflow of water/glycol through the valve. Limiting water/glycol flow to the design load of the coil has a significant effect on energy efficiency since systems operate for the majority of the time on a partial load.
 - The overflow of water/glycol causes a degradation in heat transfer at the heat exchanger.
 - Uncontrolled overflow of water/glycol beyond the design flow of the heat exchanger is an extremely wasteful and inefficient use of heat.
 - The correct and maximum design flow ensures a high differential in supply and return temperatures to provide high operational efficiency of the chiller or boiler.
- Improved Comfort
 - The SpaceLogic PIBC valves are not affected by other valves in the system that may be opening and closing throughout the day or other piping system disturbances providing more constant, comfortable, room temperatures.
- Reduced Pumping Costs
 - A reduction in overflows through the network reduces pumping costs. A smaller pump head and equipment is required compared to traditional configurations.
- Reduced Installation Costs
 - Only one valve needs to be installed rather than two or three since the SpaceLogic PIBC covers the pressure balancing, flow limitation and control modulation.
- Easy and Quick Commissioning
 - **SpaceLogic** PIBC setup time is significantly reduced with a simple and accurate flow setting procedure without the need for flow charts, calculations or measuring equipment.
- Improved Reliability
 - Improved mechanical equipment reliability from reduced actuator movements.



actuators are



Summary and Applications

Summary

SpaceLogic PIBCV valves and actuators can be used with actuators for pressure independent balancing and control applications or without actuators for automatic flow limiting balance applications. PIBCVs immediately react to all changes in system pressures, providing stable valve control independent from the fluctuating pressures in the piping system. No valve authority, pressure calculations or complicated valve flow setting calculations are required. At partial system load there is no resulting overflow because the valve always limits the flow corresponding to the design flow of the coil.

SpaceLogic PIBCV valves with actuators include an integrated control valve with flow regulation for HVAC applications, plus an automatic flow limiting function for energy efficiency. A full range of Schneider Electric actuators are available for every control application including two position, proportional, floating, spring return open, spring return close, and non-spring return.

Applications

Variable flow systems: A **SpaceLogic** PIBCV with a Schneider Electric actuator is used as a control valve for terminal units, like an AHU (Air Handling Unit), FCU (Fan Coil Unit) or radiation panel, and controls the required flow on every terminal unit maintaining hydronic balance in the system.

Constant flow systems: There are numerous applications in which **SpaceLogic** PIBCV can be used. In a constant flow system with FCUs or in a one pipe heating system, **SpaceLogic** PIBCVs can be installed as an automatic balancing valve in every riser. SpaceLogic PIBCVs limit the flow to the set value, thus automatically achieving hydronic balance. Whenever an automatic flow limiter or a control valve is needed, the advantages of cost- saving properties are inherent with **SpaceLogic** PIBCVs. This includes systems with (floor) heating/cooling, concrete core activation or radiation panels.

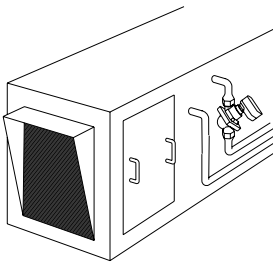
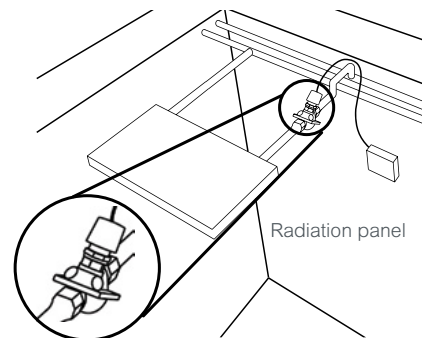
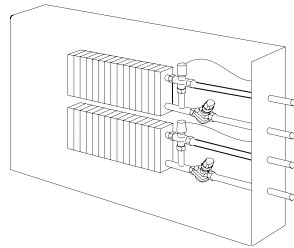
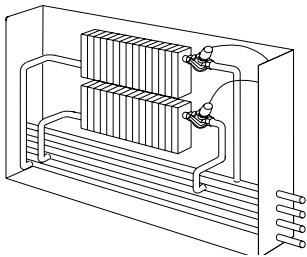

Air handling unit (AHU)

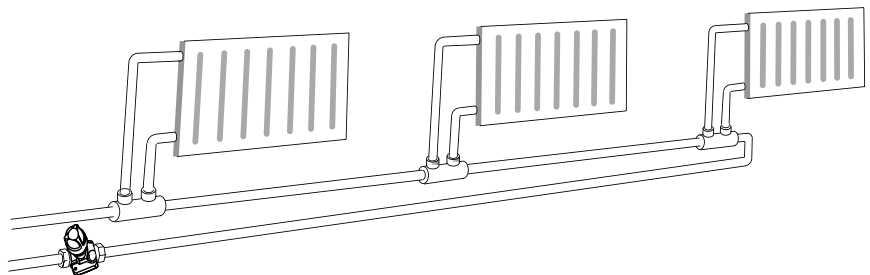

Theory and Implementation

Theory

The **SpaceLogic** PIBCV valve consists of two parts:

1. Differential Pressure Controller
2. Control Valve

1. Differential Pressure Controller (PC)

The differential pressure controller maintains a constant differential pressure across the control valve. The pressure difference is balanced so that when the differential pressure across the control valve changes (due to a change in available pressure, or movement of the control valve) the pressure regulator automatically aligns to a new position. This brings a new equilibrium and therefore keeps the differential pressure at a constant level.

2. Control Valve (CV)

The control valve has a linear characteristic. It features a stroke limitation that allows adjustment of the value. The maximum flow allowed by the control valve can be adjustable to a percentage of the valve's maximum flow rate.

Control Performance

SpaceLogic PIBCV actuators can be used to change the flow response from linear to logarithmic (equal percentage). This makes the **SpaceLogic** PIBCV suitable for all applications, including AHUs, where the equal percentage characteristic is needed to get a stable control loop. The actuators can be switched from linear to equal percentage by changing a dipswitch setting.

Easy Implementation

- No Cv or authority calculations needed. Flow is the only parameter to be considered when designing.
- Compact design, essential when only limited space is available such as in fan-coil units.
- Easy commissioning and troubleshooting. No specialized staff or measuring equipment needed.
- Trouble-free segmentation of the building project. **SpaceLogic** PIBCVs will automatically control the flow, even when sections of the installation are unfinished. There is no requirement to re-adjust the **SpaceLogic** PIBCV flow setting after finalization of the building project.

Flow Direction

A **SpaceLogic** PIBCV valve is mono-directional, meaning the valve operates when the arrow on the valve body is aligned with the flow direction. When this rule is ignored, the valve acts as a variable orifice that causes water/glycol hammer at sudden closing when available pressure has increased, or the valve has been set to a lower value.

In the case when a system condition allows backflows, it is strongly recommended to use a backflow preventer in order to avoid possible water/glycol hammer that can damage the valve as well as other elements in the system.

It is recommended to fit a strainer upstream of the valve to increase reliability and to follow water/glycol treatment guidelines as detailed in VDI 2035. The pipework system should be flushed prior to the operation.

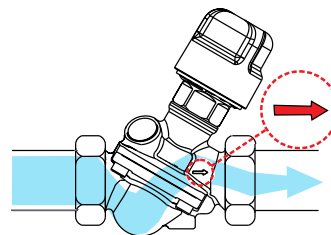
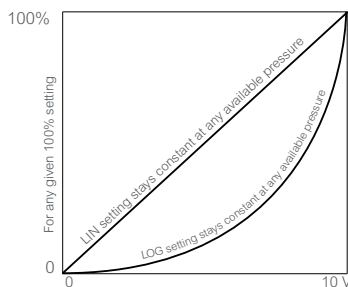

Valve assembly part number system

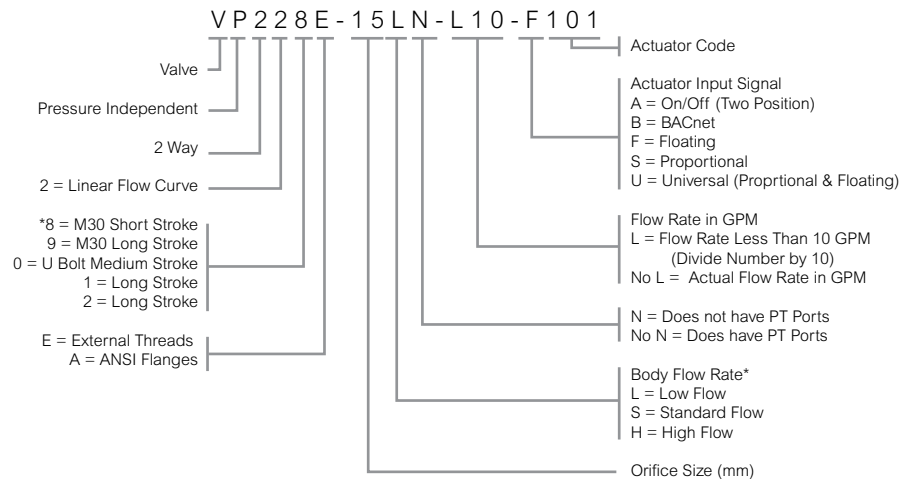

* Determined by valve size and flow; see tables 23 & 24

Methods of Selection

SpaceLogic PIBCVal selection options

There are three methods for selecting SpaceLogic PIBCVal Valves and Actuators:

1. **Complete method:** valve assembly selection.
2. **Custom method:** valve body and actuator field assembly.
3. **Valve only method:** automatic flow limited balance.

1: Complete method: valve assembly selection

To select a PIBCVal valve assembly select the required flow rate and actuator type. For example, to select a PIBCVal valve assembly with a flow rate of 1.5 GPM and a non-spring return proportional actuator refer to **“Table 1. Valve Assemblies ½ to 1¼” with Female NPT End Connectors, without PT Ports” on page 72.**

Select the 1.5 GPM flow rate with the left column of the table.

Select the actuator from the top row of the table.

The intersecting valve assembly part number from the left column and top row selections shows VP228E-15SN-L15-S101 which includes the set 1.5 GPM flow rate, installed actuator, female NPT end connectors, and metal tag with flow rate.

Specifications for the selected valve body actuators are in **“Table 3. Specification ½ to 1¼” Valve Body Actuators” on page 73 and for the valve body in “Table 12. Specification Threaded Version, ½ to 2”” on page 77.**

2. Custom method: valve body and actuator field assembly

Select the individual parts then set the flow rate and field assemble a valve assembly.

“Table 12. Specification Threaded Version, ½ to 2”” on page 77 shows the valve body specifications and “Table 23. ½ to 2” Valve Flow Ranges (Qmin to Qnom)” on page 84, and “Table 24. 2½” to 10” Flanged Valve Flow Ranges (Qmin to Qnom)” on page 85, show the valve body flow rate ranges.

For example, to select a valve body that can be used in the flow rate range of 1 to 2 GPM, from **“Table 17. Selection: ½” to 2” Valve Body Tail Pieces”” on page 80,** select the VP-228E-15BQSNT valve body that does not include PT ports, or select the VP-228E-15BSQ valve body if PT ports are required.

Other larger valves could also provide the 1 to 2 GPM flow rates, but the VP-228E-15BQSNT was selected because it will be using a higher percentage of its flow range (in general, best accuracy is achieved when a higher percentage of flow rate is used).

The ½” to 2” PIBCVal valves use convenient valve body tail pieces for connection to the piping system.

From **“Table 17. Selection: ½” to 2” Valve Body Tail Pieces”” on page 80,** select the desired ½” tail piece – part number 9112108015 for Female NPT, 9112110015 for Male NPT, or 9112109015 for Sweat. Each tail piece part number includes two tail pieces.

“Table 3. Specification ½ to 1¼” Valve Body Actuators” on page 73 shows the compatible actuators.

Select the MP131-24T for two-position control, the MP131-24F for floating control, the MP-131-24MP for proportional control, the MP300A-SRU for spring return open universal control, or the MP300A-SRD for spring return close universal control. Universal control actuators provide both proportional and floating input functionality. The valve body flow can easily be set before the actuator is installed as shown in **“PIBCVal Flow Setting” on page 71.**

3. Valve Body Only: Automatic Flow Limited Balance Example

PIBCVal valves can be used without actuators to limit the circuit flow to an adjustable flow rate.

“Table 12. Specification Threaded Version, ½ to 2”” on page 77 shows the valve body specifications and “Table 17. Selection: ½” to 2” Valve Body Tail Pieces”” on page 80 and “Table 24. 2½” to 10” Flanged Valve Flow Ranges (Qmin to Qnom)” on page 85 show the valve body flow rate ranges.

For example, to select a valve body that can be used in the flow rate range of 2 to 5 GPM from Table 23 select the VP229E-15BQHNTA Valve body part number. The ½” to 2” PIBCVal valves use convenient valve body tail pieces for connection to the piping system.

From **“Table 17. Selection: ½” to 2” Valve Body Tail Pieces”” on page 80,** select the desired ½” tail piece: part number 9112108015 for Female NPT, 9112110015 for Male NPT, or 9112109015 for Sweat. Each tail piece part number includes two tail pieces.

The 1½” and larger sized valves require a stem lock when used without an actuator as shown in “Table 11. Application: Operation of PIBCVal Valve Body Without Actuator” on page 76 (which also shows application information for the valve bodies without actuators). The valve body flow can easily be set as shown in the PIBCVal Flow Setting section.

PIBCV Flow Setting

1/2...1 1/4" Size Valves

The calculated flow can be adjusted easily without using special tools. To change the presetting (factory setting is 100% for separately purchased PIBCV valve bodies) follow the four steps below:

- ❶ Remove the black protective cover or the mounted actuator.
- ❷ Raise the green pointer.
- ❸ Turn (clock wise to decrease) to the new presetting.
- ❹ Press the pointer back into the lock position. After the pointer is clicked back into place the presetting is locked.

The presetting scale indicates values from 100% flow to 20%. Clock wise turning would decrease the flow value while counter clock wise would increase it.

Example: VP229E-15HN

With this 1/2" valve the nom flow = 5 gal/min = 100% presetting. To set a flow of 4 gal/min you have to set: $4/5 = 80\%$. Schneider Electric recommends a presetting/flow from 20% to 100%.

To set a PIBCV valve to a Q_{high} setting above 100%, turn the green pointer counter clock wise from 100%. The Q_{high} setting is the scale setting plus 90%. For example, to set the VP229E-15HN to a flow rate of 5.5 gal/min, set $5.5/5.0 = 110\%$ setting. Obtain the 110% setting by turning the green pointer counter clock wise from 100% to 20% (20% and 90% = 110%). As shown on page 77, Q_{high} settings above 100% slightly increase the valve's required minimum differential pressure.

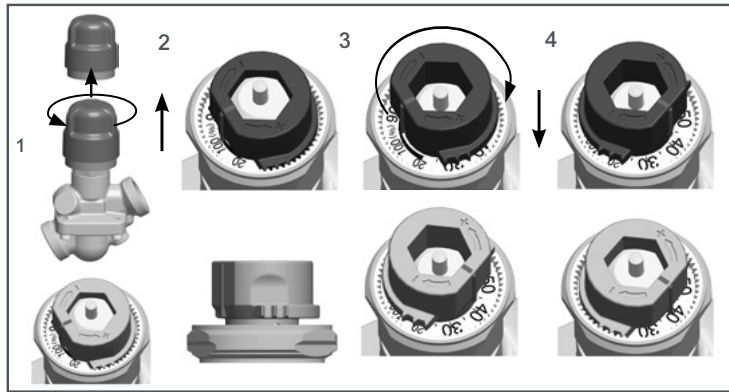

PIBCV Flow Setting 5" ...10"

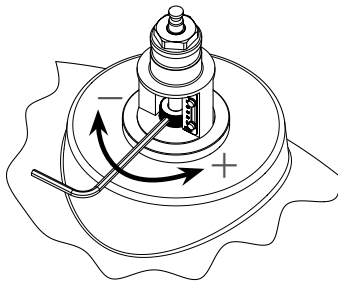

Note:
1 turn = 5%

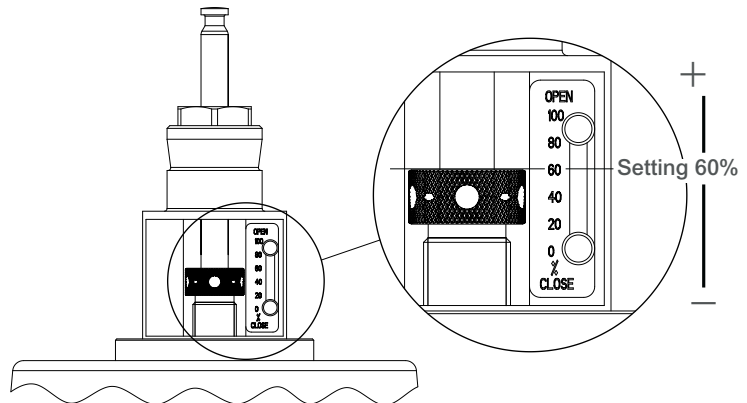

PIBCV Flow Setting 1 1/2" ...4"

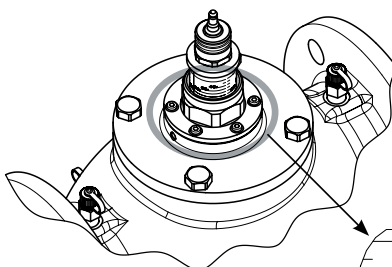

Note: 1 turn = 10%

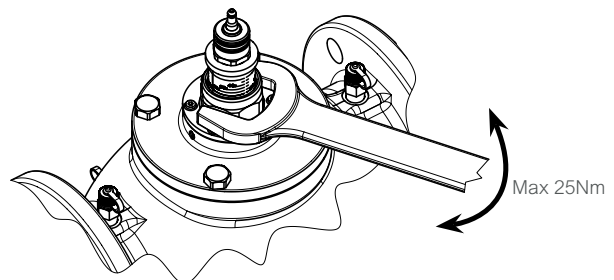
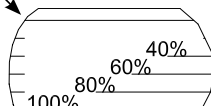

PIBCV Assemblies: 1/2" to 1 1/4" Female NPT, without PT Ports

Valve Assembly and Suitable Actuators

Table 1. Valve Assemblies 1/2" to 1 1/4" with Female NPT End Connectors, without PT Ports

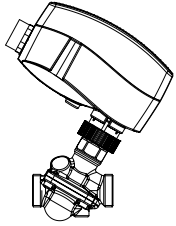
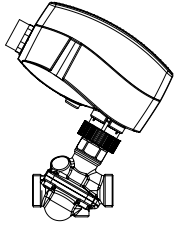
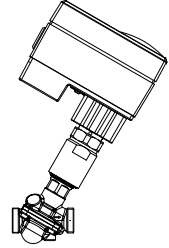
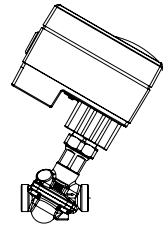
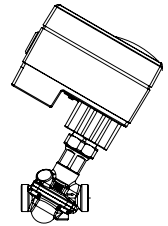
Flow rate (GPM) ^a	Valve size (inch)	24 Vac Two-position with Auxiliary switch (MP131-24T)	24 Vac Three Wire Floating with Auxiliary switch (MP131-24F)	24 Vac Proportional with Position Output Signal (MP131-24MP)	24 Vac Proportional/Floating with Position Output Signal Spring Return Open (MP300A-SRU)	24 Vac Proportional/Floating with Position Output Spring Return Closed (MP300A-SRD)
						
0.5	1/2	VP228E-10LN-L05-A101	VP228E-10LN-L05-F101	VP228E-10LN-L05-S101	VP228E-10LN-L05-U201	VP228E-10LN-L05-U301
1.0	1/2	VP228E-15LN-L10-A101	VP228E-15LN-L10-F101	VP228E-15LN-L10-S101	VP228E-15LN-L10-U201	VP228E-15LN-L10-U301
1.5	1/2	VP228E-15SN-L15-A101	VP228E-15SN-L15-F101	VP228E-15SN-L15-S101	VP228E-15SN-L15-U201	VP228E-15SN-L15-U301
2.0	1/2	VP228E-15SN-L20-A101	VP228E-15SN-L20-F101	VP228E-15SN-L20-S101	VP228E-15SN-L20-U201	VP228E-15SN-L20-U301
2.5	1/2	VP229E-15HN-L25-A101	VP229E-15HN-L25-F101	VP229E-15HN-L25-S101	VP229E-15HN-L25-U201	VP229E-15HN-L25-U301
3.0	1/2	VP229E-15HN-L30-A101	VP229E-15HN-L30-F101	VP229E-15HN-L30-S101	VP229E-15HN-L30-U201	VP229E-15HN-L30-U301
3.5	1/2	VP229E-15HN-L35-A101	VP229E-15HN-L35-F101	VP229E-15HN-L35-S101	VP229E-15HN-L35-U201	VP229E-15HN-L35-U301
4.0	1/2	VP229E-15HN-L40-A101	VP229E-15HN-L40-F101	VP229E-15HN-L40-S101	VP229E-15HN-L40-U201	VP229E-15HN-L40-U301
4.0	3/4	VP228E-20SN-L40-A101	VP228E-20SN-L40-F101	VP228E-20SN-L40-S101	VP228E-20SN-L40-U201	VP228E-20SN-L40-U301
4.5	1/2	VP229E-15HN-L45-A101	VP229E-15HN-L45-F101	VP229E-15HN-L45-S101	VP229E-15HN-L45-U201	VP229E-15HN-L45-U301
5.0	1/2	VP229E-15HN-L50-A101	VP229E-15HN-L50-F101	VP229E-15HN-L50-S101	VP229E-15HN-L50-U201	VP229E-15HN-L50-U301
5.5	3/4	VP229E-20HN-L55-A101	VP229E-20HN-L55-F101	VP229E-20HN-L55-S101	VP229E-20HN-L55-U201	VP229E-20HN-L55-U301
6.0	3/4	VP229E-20HN-L60-A101	VP229E-20HN-L60-F101	VP229E-20HN-L60-S101	VP229E-20HN-L60-U201	VP229E-20HN-L60-U301
6.5	3/4	VP229E-20HN-L65-A101	VP229E-20HN-L65-F101	VP229E-20HN-L65-S101	VP229E-20HN-L65-U201	VP229E-20HN-L65-U301
7.0	3/4	VP229E-20HN-L70-A101	VP229E-20HN-L70-F101	VP229E-20HN-L70-S101	VP229E-20HN-L70-U201	VP229E-20HN-L70-U301
7.5	3/4	VP229E-20HN-L75-A101	VP229E-20HN-L75-F101	VP229E-20HN-L75-S101	VP229E-20HN-L75-U201	VP229E-20HN-L75-U301
7.5	1	VP229E-25SN-L75-A101	VP229E-25SN-L75-F101	VP229E-25SN-L75-S101	VP229E-25SN-L75-U201	VP229E-25SN-L75-U301
8	1	VP229E-25HN-L80-A101	VP229E-25HN-L80-F101	VP229E-25HN-L80-S101	VP229E-25HN-L80-U201	VP229E-25HN-L80-U301
8.5	1	VP229E-25HN-L85-A101	VP229E-25HN-L85-F101	VP229E-25HN-L85-S101	VP229E-25HN-L85-U201	VP229E-25HN-L85-U301
9.0	1	VP229E-25HN-L90-A101	VP229E-25HN-L90-F101	VP229E-25HN-L90-S101	VP229E-25HN-L90-U201	VP229E-25HN-L90-U301
9.5	1	VP229E-25HN-L95-A101	VP229E-25HN-L95-F101	VP229E-25HN-L95-S101	VP229E-25HN-L95-U201	VP229E-25HN-L95-U301
10	1	VP229E-25HN-010-A101	VP229E-25HN-010-F101	VP229E-25HN-010-S101	VP229E-25HN-010-U201	VP229E-25HN-010-U301
11	1	VP229E-25HN-011-A101	VP229E-25HN-011-F101	VP229E-25HN-011-S101	VP229E-25HN-011-U201	VP229E-25HN-011-U301
12	1	VP229E-25HN-012-A101	VP229E-25HN-012-F101	VP229E-25HN-012-S101	VP229E-25HN-012-U201	VP229E-25HN-012-U301
13	1 1/4	VP229E-32SN-013-A101	VP229E-32SN-013-F101	VP229E-32SN-013-S101	VP229E-32SN-013-U201	VP229E-32SN-013-U301
14	1 1/4	VP229E-32SN-014-A101	VP229E-32SN-014-F101	VP229E-32SN-014-S101	VP229E-32SN-014-U201	VP229E-32SN-014-U301
15	1 1/4	VP229E-32HN-015-A101	VP229E-32HN-015-F101	VP229E-32HN-015-S101	VP229E-32HN-015-U201	VP229E-32HN-015-U301
16	1 1/4	VP229E-32HN-016-A101	VP229E-32HN-016-F101	VP229E-32HN-016-S101	VP229E-32HN-016-U201	VP229E-32HN-016-U301
17	1 1/4	VP229E-32HN-017-A101	VP229E-32HN-017-F101	VP229E-32HN-017-S101	VP229E-32HN-017-U201	VP229E-32HN-017-U301

a. Factory set. Complete flow ranges shown in tables for 1/2 to 2" on page 77.

PIBCV Assemblies: 1/2" to 1 1/4" Female NPT, with PT Ports

Table 2. Valve Assemblies 1/2" to 1 1/4" with Female NPT End Connectors, with PT Ports

Flow Rate (GPM)	Valve size (inch)	24 Vac Two-position with Auxiliary switch (MP131-24T)	24 Vac Three Wire Floating with Auxiliary switch (MP131-24F)	24 Vac Proportional with Position Output Signal (MP131-24MP)	24 Vac Proportional/Floating Spring Return Open (MP300A-SRU)	24 Vac Proportional/Floating Spring Return Closed (MP300A-SRD)
						
0.5	1/2	VP228E-10L-L05-A101	VP228E-10L-L05-F101	VP228E-10L-L05-S101	VP228E-10L-L05-U201	VP228E-10L-L05-U301
1.0	1/2	VP228E-15L-L10-A101	VP228E-15L-L10-F101	VP228E-15L-L10-S101	VP228E-15L-L10-U201	VP228E-15L-L10-U301
1.5	1/2	VP228E-15S-L15-A101	VP228E-15S-L15-F101	VP228E-15S-L15-S101	VP228E-15S-L15-U201	VP228E-15S-L15-U301
2.0	1/2	VP228E-15S-L20-A101	VP228E-15S-L20-F101	VP228E-15S-L20-S101	VP228E-15S-L20-U201	VP228E-15S-L20-U301
4.0	3/4	VP228E-20S-L40-A101	VP228E-20S-L40-F101	VP228E-20S-L40-S101	VP228E-20S-L40-U201	VP228E-20S-L40-U301
7.5	1	VP229E-25S-L75-A101	VP229E-25S-L75-F101	VP229E-25S-L75-S101	VP229E-25S-L75-U201	VP229E-25S-L75-U301
14	1 1/4	VP229E-32S-014-A101	VP229E-32S-014-F101	VP229E-32S-014-S101	VP229E-32S-014-U201	VP229E-32S-014-U301

Table 3. Specification 1/2" to 1 1/4" Valve Body Actuators

1/2" to 1 1/4" Valve Body Actuator Part Number (Actuator code)	MP131-24T (A101)	MP131-24F (F101)	MP131-24MP (S101)	MP300A-SRU (U201)	MP300A-SRD (U301)
Input signal	Two-position, 3 wire with selectable input jumper signal action selection	Three wire floating	Proportional, 0 to 10 VDC, 2 to 10 VDC, 4 to 20 mA, sequencing with selectable input signal action, DIP switch selectable	Proportional, 0 to 10 VDC, 2 to 10 VDC, 4 to 20 mA, sequencing with selectable input signal action and Floating, DIP switch selectable	
Electrical connection	Screw terminal with conduit connector				
Position feedback output signal	–	–	0 to 10 VDC	0 to 10 VDC, 2 to 10 VDC	
Spring return	–	–	–	Open valve	Close valve
Auxiliary switch	Yes	Yes	–	–	–
Other features	–	–	Weekly anti blocking selection, auto calibration, LED indication	Valve stroke length selection, LED indication	
Linear/equal% valve flow curve selection	–	–	Yes	Yes	
Actuator speed s/mm 60 Hz (50 Hz)	20 (24)			11.7 (14)	
Power consumption	1 VA		1.5 VA	9 VA	
Actuator weight (lb.)	.9			2.0	1.3
Operating temperature limits °F (°C)	32 to 131 (0 to 55)				
Regulatory compliance	cULus according to UL 60730-1A/-2-14 and CAN/CSA E60730-1/-2-14 and CE according to EN 60730-1/-2-14 per EMC [2014/30/EU] and LVD [2014/35/EU]				
Specification data sheet	F-27961			F-27962	
Installation data sheet	F-27938	F-27949	F-27948	F-27954	

All actuators are 24 Vac, 50/60 HZ with removable conduit connector plate and wiring terminal block, manual override.

PIBCV Assemblies 1½” to 4”

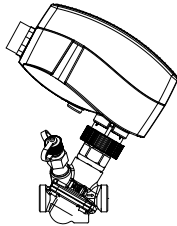
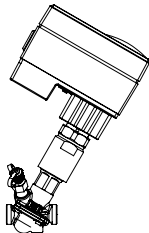
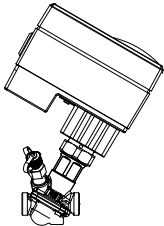
Table 4. Valve Assemblies 1½”, 2” with Female NPT End Connectors, with PT Ports

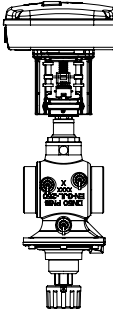
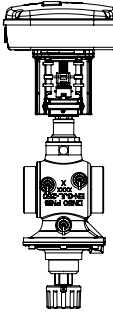
Flow rate (GPM) ^a	Valve size (inch)	24 Vac Proportional with Position Output Signal (MP500C)	24 Vac Proportional/Floating with Position Output Signal Spring Return Open (MP500C-SRU)	24 Vac Proportional/Floating with Position Output Signal Spring Return Closed (MP500C-SRD)
				
18	1½	VP220E-40S-018-U131	VP220E-40S-018-U231	VP220E-40S-018-U331
19	1½	VP220E-40S-019-U131	VP220E-40S-019-U231	VP220E-40S-019-U331
20	1½	VP220E-40S-020-U131	VP220E-40S-020-U231	VP220E-40S-020-U331
22	1½	VP220E-40S-022-U131	VP220E-40S-022-U231	VP220E-40S-022-U331
24	1½	VP220E-40S-024-U131	VP220E-40S-024-U231	VP220E-40S-024-U331
26	1½	VP220E-40S-026-U131	VP220E-40S-026-U231	VP220E-40S-026-U331
28	1½	VP220E-40S-028-U131	VP220E-40S-028-U231	VP220E-40S-028-U331
30	1½	VP220E-40S-030-U131	VP220E-40S-030-U231	VP220E-40S-030-U331
32	1½	VP220E-40S-032-U131	VP220E-40S-032-U231	VP220E-40S-032-U331
34	2	VP220E-50S-034-U131	VP220E-50S-034-U231	VP220E-50S-034-U331
36	2	VP220E-50S-036-U131	VP220E-50S-036-U231	VP220E-50S-036-U331
38	2	VP220E-50S-038-U131	VP220E-50S-038-U231	VP220E-50S-038-U331
40	2	VP220E-50S-040-U131	VP220E-50S-040-U231	VP220E-50S-040-U331
44	2	VP220E-50S-044-U131	VP220E-50S-044-U231	VP220E-50S-044-U331
48	2	VP220E-50S-048-U131	VP220E-50S-048-U231	VP220E-50S-048-U331
52	2	VP220E-50S-052-U131	VP220E-50S-052-U231	VP220E-50S-052-U331

a. Factory set

Table 5. Valve Assemblies 2½” to 4” with ANSI Standard B16.1 Flanges, with PT Ports

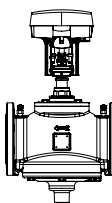
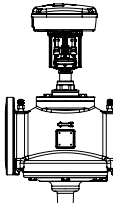
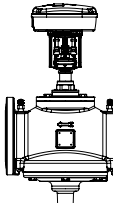
Flow rate (GPM) ^a	Valve size (inch)	24 Vac Proportional with Position Output Signal (MP500C)	24 Vac Proportional/Floating with Position Output Signal Spring Return Open (MP500C-SRU)	24 Vac Proportional/Floating with Position Output Signal Spring Return Closed (MP500C-SRD)
				
56	2½	VP220A-65S-056-U131	VP220A-65S-056-U231	VP220A-65S-056-U331
60	2½	VP220A-65S-060-U131	VP220A-65S-060-U231	VP220A-65S-060-U331
65	2½	VP220A-65S-065-U131	VP220A-65S-065-U231	VP220A-65S-065-U331
70	2½	VP220A-65S-070-U131	VP220A-65S-070-U231	VP220A-65S-070-U331
75	2½	VP220A-65S-075-U131	VP220A-65S-075-U231	VP220A-65S-075-U331
80	2½	VP220A-65S-080-U131	VP220A-65S-080-U231	VP220A-65S-080-U331
90	3	VP220A-80S-090-U131	VP220A-80S-090-U231	VP220A-80S-090-U331
100	3	VP220A-80S-100-U131	VP220A-80S-100-U231	VP220A-80S-100-U331
110 (min. 44)	2½	VP220A-65H-110-U131	VP220A-65H-110-U231	VP220A-65H-110-U331
165 (min. 66)	4	VP220A-100S-165-U131	VP220A-100S-165-U231	VP220A-100S-165-U331
176 (min. 70)	3	VP220A-80H-176-U131	VP220A-80H-176-U231	VP220A-80H-176-U331
260 (min. 104)	4	VP220A-100H-260-U131	VP220A-100H-260-U231	VP220A-100H-260-U331

a. Factory set

PIBCV Assemblies: 1½” to 6” with PT Ports and Flanges

Table 6. Specification 1½” to 4” Valve Body Actuators

1½” to 4” Valve Body Actuator part number (Actuator code)	MP500C (U131)	MP500C-SRU (U231)	MP500C-SRD (U331)
Input signal	Proportional, 0 to 10 VDC, 2 to 10 VDC, 4 to 20 mA, sequencing with selectable input signal action and Floating, DIP switch selectable		
Electrical connection	Screw terminal with conduit connector		
Position feedback output signal	2 to 10 VDC	2 to 10 VDC, 0 to 5 VDC	
Spring return	–	Open Valve	Close Valve
Auxiliary switch	Optional Module		
Other features	Auto calibration, field selectable floating input signal travel time, powered manual override	Auto calibration, field selectable floating input signal travel time	
Linear/equal% valve flow curve selection	Yes	Yes	
Flow rate (GPM)			
Actuator speed full stroke 60 Hz (50 Hz)	Proportional 15 (15) Floating 60 or 300 (60 or 300)	Proportional 15 (15) Floating 60 or 300 (60 or 300) Spring Return 13 (13)	
Power consumption	Running 15 VA, Transformer Sizing 50 VA	Running 30 VA, Transformer Sizing 50 VA	
Operating temperature limits °F (°C)	14 to 122 (-10 to 50)		
Actuator weight (lb.)	4.0	6.0	
Regulatory compliance	Underwriters Laboratory (E9429) compliance as Temperature Indicating & Regulatory Equipment cULus LISTED per UL873 and Canadian Standard C22.2 No. 24. European Community compliance per EMC directive (2014/30/EU) and LVD directive (2014/35/EU). Australian/New Zealand community RCM mark.		
Specification data sheet	F-27944	F-27945	
Installation data sheet	F-27942	F-27943	

Table 7. Valve Assemblies 5” and 6” With PT Ports with ANSI Standard B16.1 Flanges

Flow rate (GPM) a	Valve size (inch)	24 Vac Proportional with Position Output Signal (MP2000-NSR)	24 Vac Proportional/Floating with Position Output Signal Spring Return Open (MP2000A-SRU)	24 Vac Proportional/Floating with Position Output Spring Return Closed (MP2000A-SRD)
				
395 (min. 158)	5	VP220A-125S-395-U161	VP220A-125S-395-U261	VP220A-125S-395-U361
485 (min. 194)	5	VP220A-125H-485-U161	VP220A-125H-485-U261	VP220A-125H-485-U361
640 (min. 256)	6	VP220A-150S-640-U161	VP220A-150S-640-U261	VP220A-150S-640-U361
830 (min. 332)	6	VP220A-150H-830-U161	VP220A-150H-830-U261	VP220A-150H-830-U361

Table 8. Specification 5”and 6” Valve Body Actuators

5” and 6” Valve Body Actuator part number (Actuator code)	MP2000-NSR (U161)	MP2000A-SRU (U261)	MP2000A-SRD (U361)
Input signal	Proportional, 0 to 10 VDC, 2 to 10 VDC, 0 to 20 mA, 4 to 20 mA, with selectable input signal action and Floating, DIP switch selectable		
Electrical connection	Screw terminal with conduit connector		
Position feedback output signal	0 to 10 VDC, 2 to 10 VDC, 0 to 20 mA, 4 to 20 mA a		
Spring return	–	Open Valve	Close Valve
Auxiliary switch	Yes		
Other features	Auto calibration, 3-color LED indication, powered manual override, configurable position output signals, selectable speed, adjustable equal percentage flow curve		
Linear/equal% valve flow curve selection	Yes		
Flow rate (GPM)			
Actuator speed s/mm 60 Hz (50 Hz)	3 or 6 (3 or 6)	4 or 6 (4 or 6)	
Power consumption	15.0 VA		
Operating temperature limits °F (°C)	32 to 131 (0 to 55)		
Actuator weight (lb.)	13.8	18.96	
Regulatory compliance	cULus according to UL 60730-1A/-2-14 and CAN/CSA E60730-1/-2-14 and CE according to EN 60730-1/-2-14 per EMC [2014/30/EU] and LVD [2014/35/EU]		
Specification data sheet	F-27976	F-27969	
Installation data sheet	F-27956		

a. When used with a proportional input signal. All actuators are 24 Vac. 50/60 HZ with conduit connector holes and wiring terminal block, manual override.

PIBCV Assemblies: 8" and 10" with PT Ports and Flanges

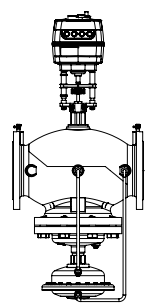
Table 9. Valve Assembly 8" and 10" With PT Ports

Flow rate (GPM)	* Valve size (inch)	24 Vac Proportional with Position Output Signal (MP4000A)
880 (min. 352)	8	VP222A-200S-880-U181
1188 (min. 475)	8	VP222A-200H-1188-U181
1320 (min. 528)	10	VP222A-250S-1320-U181
1630 (min. 652)	10	VP222A-250H-1630-U181

* Factory set.

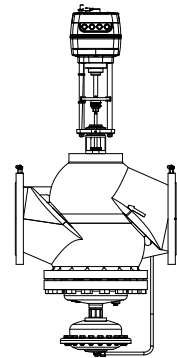

Table 10. Specification 8" and 10" Valve Body Actuators

8" and 10" Valve Body Actuator part number (Actuator code)	MP4000A (U181)
Input signal	Proportional, 0 to 10 VDC, 2 to 10 VDC, 0 to 20 mA, 4 to 20 mA, with selectable input signal action and Floating, DIP switch selectable
Electrical connection	Screw terminal with conduit connector
Position feedback output signal	0 to 10 VDC, 2 to 10 VDC, 0 to 20 mA, 4 to 20 mA a
Spring return	-
Auxiliary switch	Yes
Other features	Auto calibration, LED indication, powered manual override, adjustable speed
Linear/equal% valve flow curve selection	Yes
Actuator speed s/mm 60Hz (50 Hz)	3 or 6 (3 or 6)
Power consumption	15 VA
Operating temperature limits °F (°C)	32 to 131 (0 to 55)
Actuator weight (lb.)	16.53
Regulatory compliance	cULus according to UL 60730-1A/-2-14 and CAN/CSA E60730-1/-2-14 and CE according to EN 60730-1/-2-14 per EMC [2014/30/EU] and LVD [2014/35/EU]
Specification data sheet	F-27971
Installation data sheet	F-27958

a. When used with a proportional input signal.

All actuators are 24 Vac. 50/60 HZ with conduit connector holes and wiring terminal block, manual override.

Table 11. Application: Operation of PIBC Valve Body Without Actuator
Operation of the PIBC valve body without an actuator for an automatic flow limiting balancing application.

PIBC valve size	Valve body series	Valve Stem Lock part number	Recommended installation and valve shut off capability
1/2" to 1-1/4"	VP228E-xxxxxx, VP229E-xxxxxx	Use black cap provided with VP228E-xxxxxx or VP229E-xxxxxx valve body	Install valve in the supply water pipe for best shut off valve performance. To shutoff the valve, tighten black cap (max. Close off pressure is 14.5 psi). To shut off against a higher differential pressure set the valve flow to 0%.
1-1/2", 2"	VP220E-xxxxx	9114070000 (not included with valve body)	Install valve in either the supply or return water pipe. To shut off valve tighten bottom knob (max. Close off pressure is 232 psi).
2-1/2" to 4"	VP220A-xxxxx		Install valve in either the supply or return water pipe. To shut off valve tighten bottom insert with a 8 mm allen wrench (max. Close off pressure is 232 psi).
5" to 6"	VP221A-xxxxxx	9114071000 (not included with valve body)	No shut off knob, set the valve to a 0% flow setting to shut off flow.
8" to 10"	VP222A-xxxxx	9114072000 (not included with valve body)	

The 9114070000, 9114071000, and 9114072000 Valve Stem Locks are secured to the valve body with a 10 mm allen wrench.

PIBCV Specifications: Threaded 1/2" to 2"

Technical data

Table 12. Specification Threaded Version, 1/2" to 2"

* Factory set.

Valve size		1/2"				3/4"		1"		1 1/4"		1 1/2"	2"
Valve assembly part number without PT Ports 1)		VP228E-10LN-	VP228E-15LN-	VP228E-15SN-	VP229E-15HN-	VP228E-20SN-	VP229E-20HN-	VP229E-25SN-	VP229E-25HN-	VP229E-32SN-	VP229E-32HN-	-	-
Valve assembly part number with PT Ports 1)		VP228E-10L-	VP228E-15L-	VP228E-15S-	-	VP228E-20S-	-	VP229E-25S-	-	VP229E-32S-	-	VP220E-40S-	VP220E-50S-
Flow range	Q _{min}	.13	.24	.4	1	.8	1.5	1.5	2.4	2.82	3.5	13.2	22
	Q _{nom} (100%) ²⁾	.66	1.2	2	5	4	7.5	7.5	12	14.1	17.5	33	55
	Q _{high}	.79	1.45	2.4	5.5	4.75	8.25	8.2	13.2	15.5	19.25	33	55
Setting range 3)		20-120%				20-110%	20-120%	20-110%				40-100%	
Diff. pressure 4), 5)	Δp _{Q_{nom}} (Δp _{Q_{high}})	2.32-58 (2.61-58) [16-400 (18-400)]			5-58 (5.8-58) [35-400 (40-400)]	2.32-58 (2.61-58) [16-400 (18-400)]	5-58 (5.8-58) [35-400 (40-400)]	2.9-58 (3.63-58) [20-400 (25-400)]	5-58 (5.8-58) [35-400 (40-400)]	2.9-58 (3.63-58) [20-400 (25-400)]	5-58 (5.8-58) [35-400 (40-400)]	4.35-58 [30-400]	
	Stroke Q _{nom}	0.09 (2.25)			.157 (4)	0.09 (2.25)	.157 (4)	.177 (4.5)				.39 (10)	
Connection	ext. thread (ISO 228/1)	G 1/2 A			G 3/4 A	G 1 A		G 1 1/4 A		G 1 1/2 A		G 2 A	G 2 1/2 A
	actuators	MP131-24T, MP131-24F, MP131-24MP, MP300A-SRU, MP300A-SRD										MP500C, MP500C-SRU/SRD	
Body pressure rating	psi	EN 12516-2:2004, 250 psi, PN 16											
Leakage acc. to standard IEC 60534		Class 4, max. 0.01% of Q _{nom}						max. 0.05% of Q _{nom}					
Max. close off differential pressure across the valve		232 psi (16 bar)											
Control range		Acc. to standard IEC 60534 control range is high as flow characteristic is linear (1:1000)											
Control valve's characteristic		Stem up open, Linear (can be converted by actuator to equal percentage)											
For shut off function		Acc. to ISO 5208 class A - no visible leakage											
Flow medium		Water and water mixture for closed heating and cooling systems according to plant type I for DIN EN 14868. When used in plant Type II for DIN EN 14868 appropriate protective measures are taken. The requirements of VDI 2035, part 1 + 2 are observed.											
Medium temperature	°F (°C)	(water/glycol) 15 to 250 (-10 - +120)											

Materials in the water/glycol

Valve bodies	Dezincification Resistant Brass (CuZn36Pb2As - CW 602N) per EN 12420	Grey iron EN-GJL-250 (GG 25) per EN 1561
Cone (Pc)	Stainless Steel, W.Nr. 1.4305	Wrought copper CuZn40Pb3-CW 614N, Stainless Steel, W.Nr. 1.4305
Seat (Pc)	EPDM	Stainless Steel, W.Nr. 1.4305
Seat (Cv)	Dezincification Resistant Brass (CuZn36Pb2As - CW 602N)	Stainless Steel, W.Nr. 1.4305
Membranes and O-rings	EPDM	
Springs	Stainless Steel, W.Nr. 1.4568, W.Nr. 1.4310	
Cone (Cv)	Wrought copper, CuZn40Pb3 - CW 614N	
Screw	Stainless Steel (A2)	
Flat gasket	NBR	
Sealing agent (only for valves with PT Ports)	Dimethacrylate Ester	

Materials out of the water/glycol

Plastic parts	PA	POM
Insert parts and outer screws	CuZn39Pd3 - CW614N	-

Note: Water/glycol compatibility: It is the responsibility of the installer or product specifier to verify water/glycol compatibility of the valves construction materials with the supplier of water/glycol treatment/heat transfer solution.

- 1) See "Table 15. Assembly Valve Body Configurations" on page 79 for a listing of all PIBCV Valve body part numbers.
- 2) Factory setting of the valve is done at Q_{nom} (100%) or lower depending on flow rate ordered.
- 3) Regardless of the setting, the valve can modulate below 1% of set flow.
- 4) Δp = (P1-P3) min-max
- 5) 87 psi Δp is possible if consideration has been made to the flow velocity, cavitation and noise. For application usage, please speak with Product Support.
Pc - Pressure controller
Cv - Control valve

PIBCV Specifications: 2½” to 10” Flange Version

Table 13. Specification Flange Version, 2½” to 4”

Valve size			2½"		3"		4"	
Part Number			VP220A-65S	VP220A-65H	VP220A-80S	VP220A-80H	VP220A-100S	VP220A-100H
Flow range	Q _{min}	gal/min	34	44	48	70	66	104
	Q _{nom} (100%) 1)		85	110	120	176	165	260
Setting range 2)		%	40-100%					
Diff. pressure 3), 4)	ΔpQ _{nom}	psi [kPa]	4.35-58 [30-400]	8.7-58 (60-400)	4.35-58 (30-400)	8.7-58 (60-400)	4.35-58 (30-400)	8.7-58 (60-400)
Body pressure rating psi			Class 125 per ASME B16.1-2010 Material Class B per ASTM A 126-04 (2014), 200 psi to 150°F, 190 psi to 200°F, 180 psi to 225°F, 175 psi to 250°F					
Control valve's characteristic			Stem up open, Linear (can be converted by actuator to equal percentage)					
Leakage acc. to standard IEC 60534			Max. 0.05% of Q _{nom}					
Max. close off differential pressure across the valve			232 psi (16 bar)					
For shut off function			Acc. to ISO 5208 class A - no visible leakage					
Flow medium			Water and water mixture for closed heating and cooling systems according to plant type I for DIN EN 14868. When used in plant Type II for DIN EN 14868 appropriate protective measures are taken. The requirements of VDI 2035, part 1 + 2 are observed.					
Medium temperature		°F (°C)	(water/glycol) 15 to 250 (-10 - +120)					
Stroke Q _{nom}		in. (mm)	.59 (15)					
Connection	flange		ANSI Class 125					
	actuators		MP500C, MP500C-SRU, MP500C-SRD					

Materials in the water/glycol

Valve bodies	Grey iron EN-GJL-250(GG25)
Membranes / Bellow / O-rings	EPDM
Springs	Stainless Steel, W.Nr. 1.4568, W.Nr. 1.4310
Cone (Pc)	Wrought copper, CuZn40Pb3 - CW 614N, Stainless Steel, W.Nr. 1.4305
Seat (Pc) / Seat (Cv)	W.Nr. 1.4305
Cone (Cv)	CuZn40Pb3 - CW 614N
Screw	Stainless Steel (A2)
Flat gasket	NBR

Table 14. Specification Flange Version, 5” to 10”

Valve size			5"		6"		8"		10"	
Part Number			VP220A-125S	VP220A-125H	VP220A-150S	VP220A-150H	VP222A-200S	VP222A-200H	VP222A-250S	VP222A-250H
Flow range	Q _{min}	gal / min	158	194	256	332	352	475	528	652
	Q _{nom} (100%) 1)		395	485	640	830	880	1188	1320	1630
Setting range 2)		%	40-110%							
Diff. pressure 3)	ΔpQ _{nom}	psi [kPa]	5.8-58 [40-400]	8.7-58 [60-400]	5.8-58 [40-400]	8.7-58 [60-400]	5.8-58 [40-400]	8.7-58 [60-400]	5.8-58 [40-400]	8.7-58 [60-400]
Leakage acc. to standard IEC 60534			Class 4, max. 0.01% of Q _{nom}							
Max. close off differential pressure across the valve			232 psi (16 bar)							
Connection	flange		ANSI Class 125				EN 1092			
	actuators		MP2000-NSR, MP2000A-SRU, MP2000A-SRD				MP4000A			
Flow medium			Water and water mixture for closed heating and cooling systems according to plant type I for DIN EN 14868. When used in plant Type II for DIN EN 14868 appropriate protective measures are taken. The requirements of VDI 2035, part 1 + 2 are observed.							
Body pressure rating psi			Class 125 per ASME B16.1-2010 Material Class B per ASTM A 126-04 (2014), 200 psi to 150°F, 190 psi to 200°F, 180 psi to 225°F, 175 psi to 250°F							
Control range			Acc. to standard IEC 60534 control range is high as flow characteristic is linear.							
Control valve's characteristic			Stem up open, Linear (could be converted by actuator to equal percentage)							
Medium temperature		°F (°C)	(water/glycol) 15 to 250 (-10 - +120)							
Stroke (Q _{nom})		in. (mm)	1.18 (30)							
Materials in the water/glycol										
Valve bodies			Grey iron EN-GJL-250 (GG 25)							
Membranes/ Bellow / O-Rings			W.Nr.1.4571				EPDM			
Springs			Stainless Steel, W.Nr.1.4401				Stainless Steel, W.Nr.1.4310			
Cone (Pc) / Cone (Cv)			Stainless Steel, W.Nr.1.4404NC				Stainless Steel, W.Nr.1.4021			
Flat gasket			Graphite gasket				Non asbestos			
Seat (Pc) / Seat (Cv)			Stainless Steel, W.Nr.1.4027							
Screw			Stainless Steel, W.Nr.1.1181							

1) Factory setting of the valve is done at Q_{nom} (100%) or lower depending on flow rate ordered.

2) Regardless of the setting, the valve can modulate below 1% of set flow.

3) Δp = (P1-P3) min-max

4) 87 psi Δp is possible if consideration has been made to the flow velocity, cavitation and noise. For application usage, please contact Product Support

Pc - Pressure controller

Cv - Control valve

PIBCV Assembly Valve Body Configurations

Table 15. Assembly Valve Body Configurations

Pipe size (in.)	Valve Assembly part number series	Complete Valve Body part number	Valve type	Female NPT End Connectors (included with all 1/2" through 2" Valve Actuator Assemblies)	PT ports	Installation data sheet
1/2	VP228E-10LN-	VP228E-10BQLNTA	Threaded	911 2108 010		F-27937
1/2	VP228E-10L-	VP228E-10BQLA	Threaded	911 2108 010	Yes	
1/2	VP228E-15LN-	VP228E-15BQLNTA	Threaded	911 2108 015		
1/2	VP228E-15L-	VP228E-15BQLA	Threaded	911 2108 015	Yes	
1/2	VP228E-15SN-	VP228E-15BQSNTA	Threaded	911 2108 015		
1/2	VP228E-15S-	VP228E-15BQSA	Threaded	911 2108 015	Yes	
1/2	VP229E-15HN-	VP229E-15BQHNTA	Threaded	911 2108 015		
3/4	VP228E-20SN-	VP228E-20BQSNTA	Threaded	911 2108 020		
3/4	VP228E-20S-	VP228E-20BQSA	Threaded	911 2108 020	Yes	
3/4	VP229E-20HN-	VP229E-20BQHNTA	Threaded	911 2108 020		
1	VP229E-25SN-	VP229E-25BQSNTA	Threaded	911 2108 025		
1	VP229E-25S-	VP229E-25BQSA	Threaded	911 2108 025	Yes	
1	VP229E-25HN-	VP229E-25BQHNTA	Threaded	911 2108 025		
1-1/4	VP229E-32SN-	VP229E-32BQSNTA	Threaded	911 2108 032		
1-1/4	VP229E-32S-	VP229E-32BQSA	Threaded	911 2108 032	Yes	
1-1/4	VP229E-32HN-	VP229E-32BQHNTA	Threaded	911 2108 032		
1-1/2	VP220E-40S-	VP220E-40CQSA	Threaded	911 2108 040	Yes	F-27934
2	VP220E-50S-	VP220E-50CQSA	Threaded	911 2108 050	Yes	
2-1/2	VP220A-65S-	VP220A-65CQS	Flanged		Yes	
2-1/2	VP220A-65H	VP220A-65CQH	Flanged		Yes	
3	VP220A-80S-	VP220A-80CQS	Flanged		Yes	
3	VP220A-80H	VP220A-80CQH	Flanged		Yes	
4	VP220A-100S-	VP220A-100CQS	Flanged		Yes	
4	VP220A-100H	VP220A-100CQH	Flanged		Yes	
5	VP220A-125S-	VP221A-125CQS	Flanged		Yes	F-27939
5	VP220A-125H-	VP221A-125CQH	Flanged		Yes	
6	VP220A-150S-	VP221A-150CQS	Flanged		Yes	
6	VP220A-150H-	VP221A-150CQH	Flanged		Yes	
8	VP222A-200S-	VP222A-200CQS	Flanged		Yes	
8	VP222A-200H-	VP222A-200CQH	Flanged		Yes	
10	VP222A-250S-	VP222A-250CQS	Flanged		Yes	
10	VP222A-250H-	VP222A-250CQH	Flanged		Yes	

PIBCV Valve Actuator Codes and 1/2" to 2" Tail Pieces

Table 16. Selection: Valve Actuator codes

Actuator part number	Actuator code	Valve sizes	Non spring return	Spring return open	Spring return close
MP131-24T	A101	1/2" to 1 1/4"	•		
MP131-24F	F101				
MP131-24MP	S101				
MP300A-SRU	U201			•	
MP300A-SRD	U301				•
MP500C	U131	1 1/2" to 4"	•		
MP500C-SRU	U231			•	
MP500C-SRD	U331				•
MP2000-NSR	U161	5" and 6"	•		
MP2000A-SRU	U261			•	
MP2000A-SRD	U361				•
MP4000A	U181	8" and 10"	•		

Table 17. Selection: 1/2" to 2" Valve Body Tail Pieces*

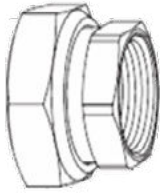
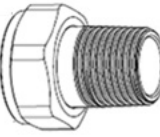
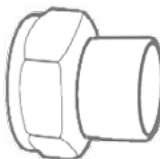
	Part number	Pipe size	(A) Approximate length inches (mm)	Approximate nut size inches (mm)	(B) Approximate Valve Body thread engagement inches (mm)	Comments	Image
Female NPT Two Female NPT Connectors, Two Gaskets	911 2108 010	1/2"	1.1 (28)	0.99 (25)	0.29 (7.2)	For VP228E-10BQLNNTA and VP228E-10BQLA 1/2" valve bodies only	
	911 2108 015	1/2"	1.1 (28)	1.19 (30.2)	0.29 (7.2)	For all 1/2" valve bodies except VP228E-10BQLNNTA and VP228E-10BQLA	
	911 2108 020	3/4"	1.26 (32)	1.46 (37)	0.33 (8.4)	For all 3/4" valve bodies	
	911 2108 025	1"	1.5 (38)	1.81 (45.8)	0.41 (10.4)	For all 1" valve bodies	
	911 2108 032	1-1/4"	1.65 (42)	2.05 (52.1)	0.42 (10.7)	For all 1-1/4" valve bodies	
	911 2108 040	1-1/2"	1.85 (47)	2.52 (63.9)	0.55 (14)	For 1-1/2" valve body	
	911 2108 050	2"	1.93 (49)	3.24 (82.2)	0.69 (17.5)	For 2" valve body	
Male NPT Two Male NPT Connectors, Two Nuts, Two Gaskets	911 2110 010	3/8"	1.24 (31.5)	0.99 (25)	0.29 (7.2)	For VP228E-10BQLNNTA and VP228E-10BQLA 1/2" valve bodies only	
	911 2110 015	1/2"	1.32 (33.5)	1.19 (30.2)	0.29 (7.2)	For all 1/2" valve bodies except VP228E-10BQLNNTA and VP228E-10BQLA	
	911 2110 020	3/4"	1.5 (38)	1.46 (37)	0.33 (8.4)	For all 3/4" valve bodies	
	911 2110 025	1"	1.73 (44)	1.81 (45.8)	0.41 (10.4)	For all 1" valve bodies	
	911 2110 032	1-1/4"	1.85 (47)	2.05 (52.1)	0.42 (10.7)	For all 1-1/4" valve bodies	
	911 2110 040	1-1/2"	2.28 (58)	2.52 (63.9)	0.55 (14)	For 1-1/2" valve body	
	911 2110 050	2"	2.81 (71.5)	3.24 (82.2)	0.69 (17.5)	For 2" valve body	
Female Sweat Two Female Sweat Ends, Two Nuts, Two Gaskets	911 2109 010	3/8" Tubing (with 1/2" OD)	1.06 (27)	0.99 (25)	0.29 (7.2)	For VP228E-10BQLNNTA and VP228E-10BQLA 1/2" valve bodies only	
	911 2109 015	1/2" Tubing (with 5/8" OD)	1.32 (33.5)	1.19 (30.2)	0.29 (7.2)	For all 1/2" valve bodies except VP228E-10BQLNNTA and VP228E-10BQLA	
	911 2109 020	3/4" Tubing (with 7/8" OD)	1.5 (38)	1.46 (37)	0.33 (8.4)	For all 3/4" valve bodies	
	911 2109 025	1" Tubing (with 1-1/8" OD)	1.73 (44)	1.81 (45.8)	0.41 (10.4)	For all 1" valve bodies	
	911 2109 032	1-1/4" Tubing (with 1-3/8" OD)	1.85 (47)	2.05 (52.1)	0.42 (10.7)	For all 1-1/4" valve bodies	
	911 2109 040	1-1/2" Tubing (with 1-5/8" OD)	2.36 (60)	2.52 (63.9)	0.55 (14)	For 1-1/2" valve body	
	911 2109 050	2" Tubing (with 2-1/8" OD)	2.81 (71.5)	3.24 (82.2)	0.69 (17.5)	For 2" valve body	

* Female NPT End Connectors (included with all 1/2" through 2" Valve Actuator Assemblies).

PIBCV Dimensions: Threaded 1/2" to 2"

Dimensions Threaded Valves 1/2 to 1 1/4" (inches)

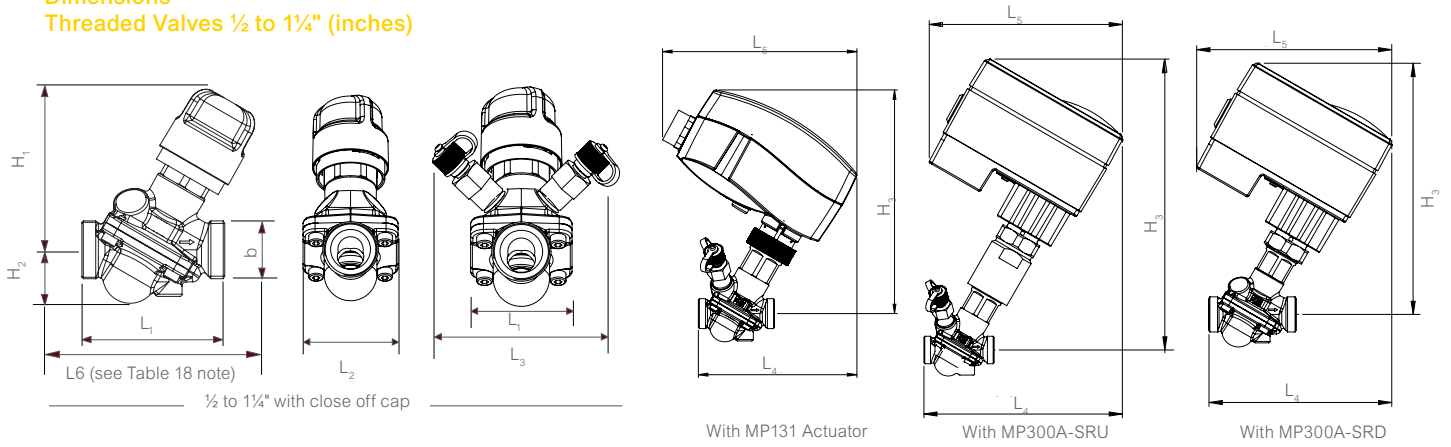

Table 18. Threaded Valves 1/2 to 1 1/4" (inches)

Type	L1	L2	L3 (PLUGS)	L4			L5		H1	H2	H3		b ISO 228/1	Valve Body Weight (lb.)
				MP131	MP300 -SRU	MP300 -SRD	MP131	MP300 -SRU/SRD			MP131	MP300 -SRU/SRD		
1/2" VP228E-10Lx	2	1.41	3.11	4.37	5.11	5.90	5.35	5.7	2.9	.78	5.6	7.2	G 1/2	.83
1/2"	2.5	1.7		4.64	5.39	6.14			3	1	5.7	7.4	G 3/4	1
3/4"	3.2	2.2		4.96	5.7	6.53			3	1.2	5.8	7.5	G 1	1.43
1"	4	2.7		5.55	6.3	7.08			3.5	1.5	6.14	7.83	G 1 1/4	3.2
1 1/4"	5.1	3.5		6.26	7	7.8			3.9	2.3	6.58	8.27	G 1 1/2	4.8

For assemblies with Female NPT: L6= (2x Column A - 2x Column B) +L1

Threaded Valves 1 1/2" and 2" (inches)

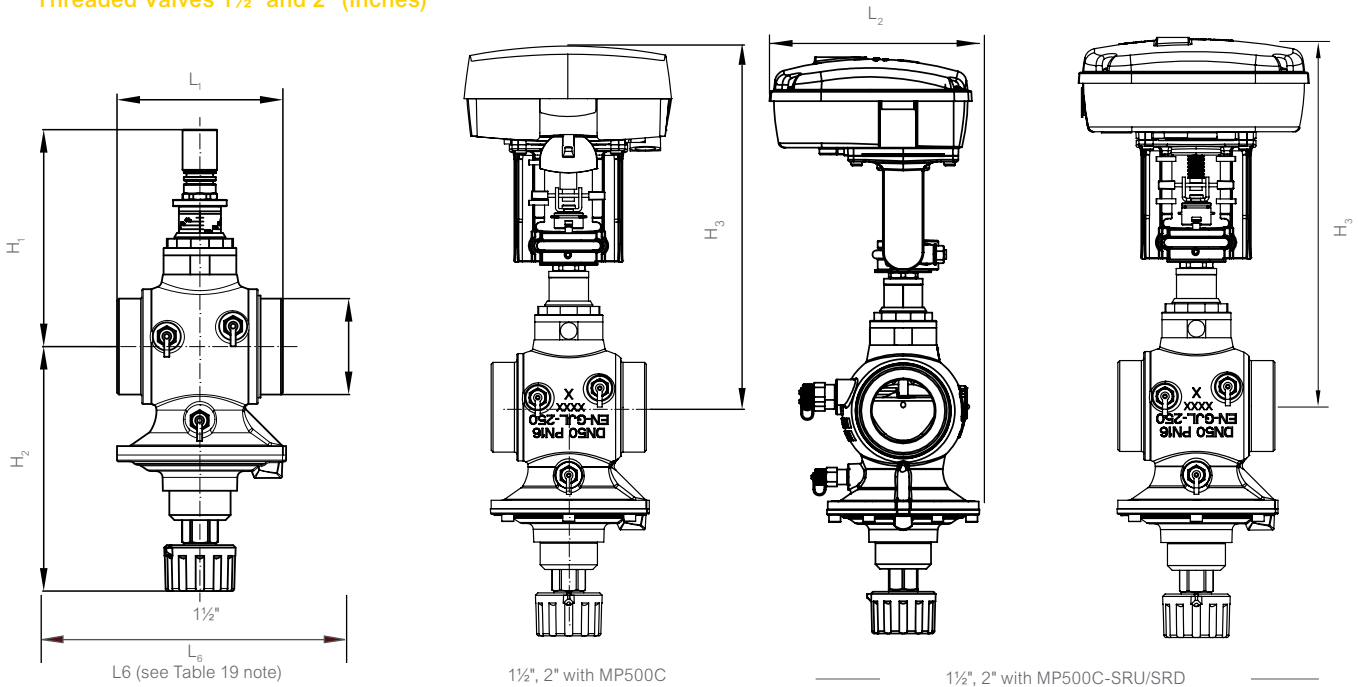

Table 19. Threaded Valves 1 1/2" and 2" (inches)

Type	L1	L2	H1	H2	H3	b ISO 228/1	Valve Body Weight lb
1 1/2"	4.33	7.19	6.7	6.85	11	G 2	15.8
2"	5.11					G 2 1/2	18.0

PIBCV Dimensions: 2½” to 6” Flanged Valves

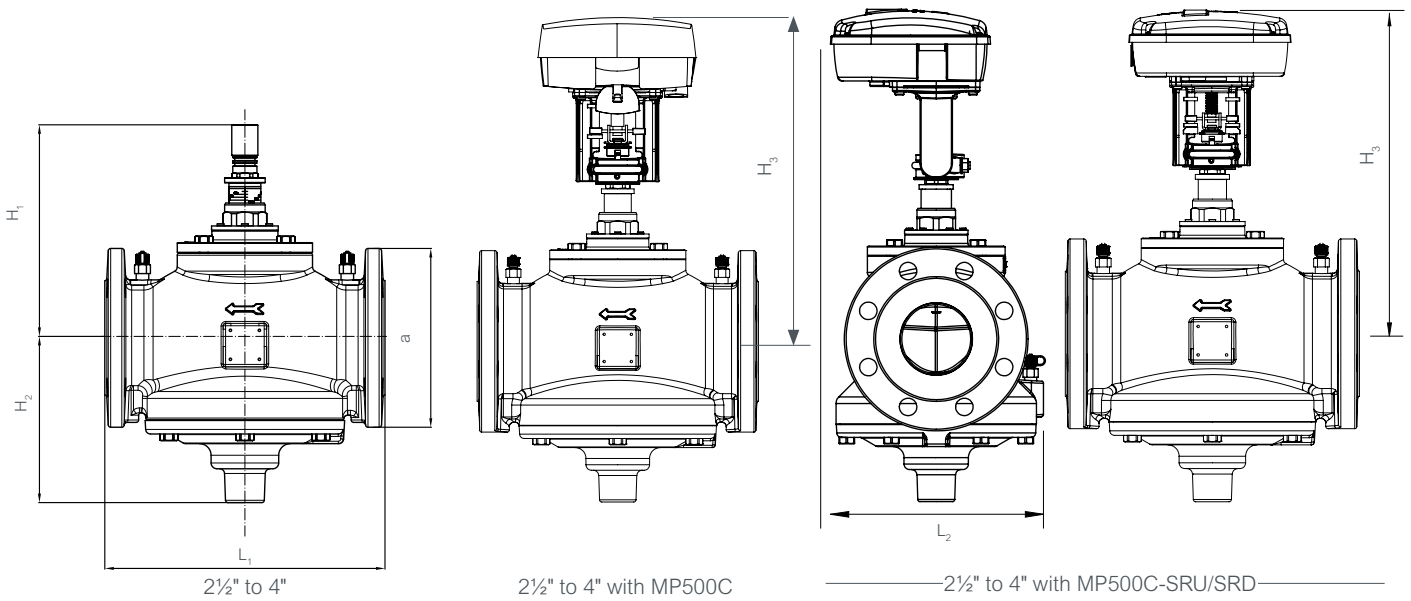

Table 20. Flanged Valves 2½” to 4” (inches)

Type	L1	L2	H1	H2	H3	a (EN 1092-2)	Valve Body Weight (lb)	No. of Flange Bolt Holes
2½”	11.4	8.76	8.6	6.77	13	7.2	84	4
3”	12.2	8.88	8.9	6.96	13.1	7.87	99	4
4”	13.7	10.07	9.44	7.36	13.7	8.66	126	8

Flanged Valves 5” and 6”

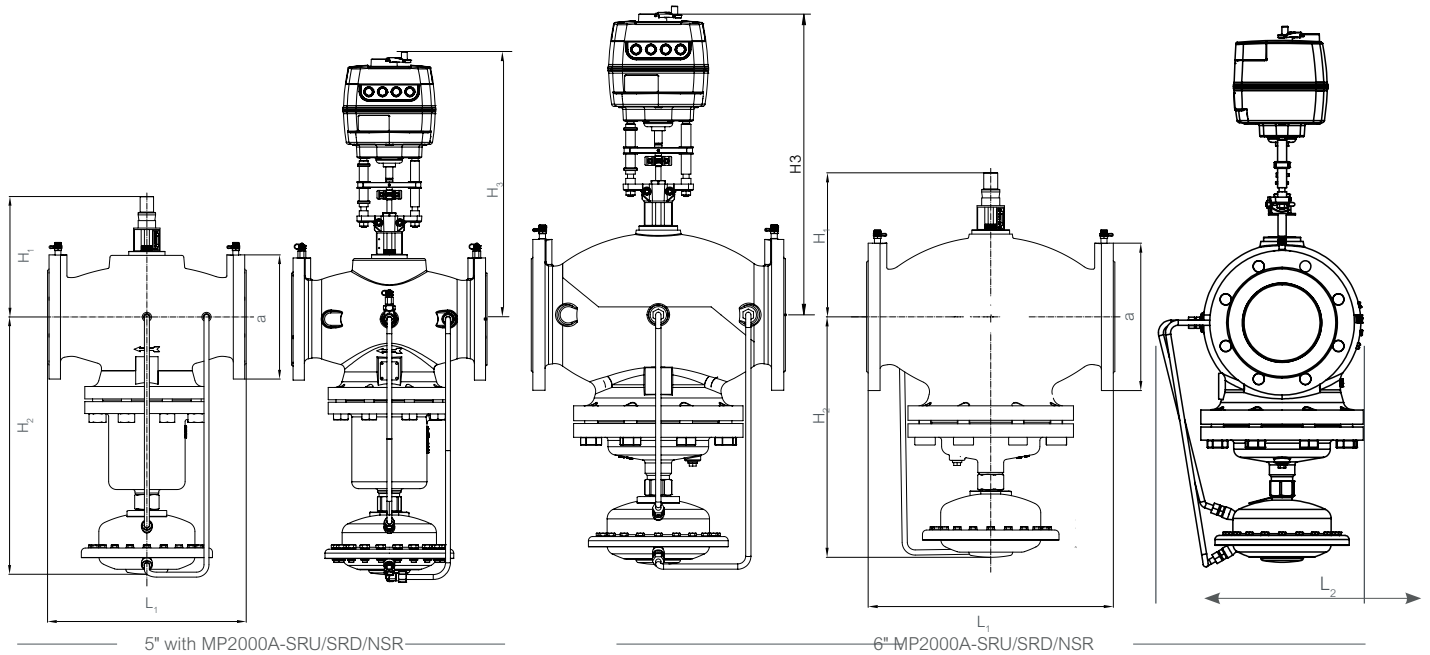

Table 21. Flanged Valves 5” and 6” (inches)

Type	L1	L2	H1	H2	H3 MP2000A-SRU/SRD/NSR	a (EN 1092-2)	Valve Body Weight (lb.)	No. of Flange Bolt Holes
5”	15.7	14.45	10.7	21.1	20.94	9.84	188	8
6”	18.9	15.88	12.1	19.6	22.36	11.22	304	8

PIBCV Dimensions: 8" and 10" Flanged and Adaptors

Flanged Valves 8" and 10"

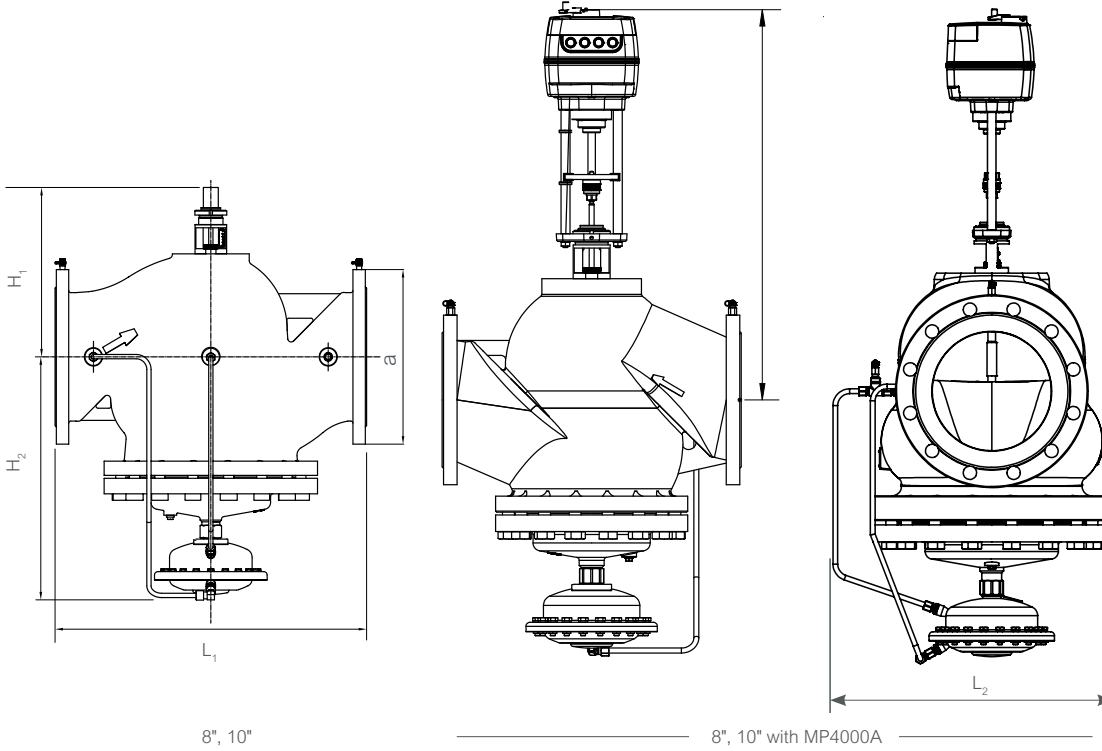
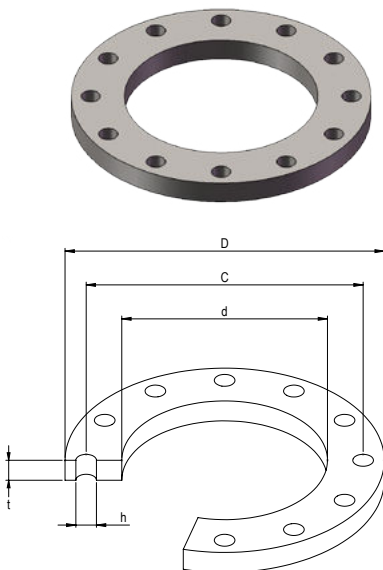

Table 22a. Flanged Valves 8" and 10" (inches)

Type	L1	L2	H1	H2	H3 MP4000A	a (EN 1092-2)	Valve body weight (lb.)	No. of flange bolt holes
8"	23.6	19.57	17.0	19.0	24.3	13.38	482	12
10"	28.7	22.98	16.9	20.9	27.8	15.9	753	12

Table 22b. Valve Flange Adaptors 8" and 10"



Specifications and part numbers

Size	8" (200 mm)	10" (250mm)
Part number	D2576-16-200	D2576-16-250
Bolt hole diameter	.87" (22 mm)	1.02" (25.9 mm)
Bolt circle	11.61" (294.89 mm)	13.98" (355.09 mm)
Pressure	PN16	
d	8.63" (219.1 mm)	10.75" (273mm)
D	13.39" (340 mm)	15.94" (405mm)
C	11.61" (295 mm)	13.98" (355mm)
Number of bolts	12	
h	0.87" (22 mm)	1.02" (26mm)
t	1.024" (26 mm)	1.14" (29mm)
Weight	24.03 lbs (10.9 kg)	39.68 lbs (18.0 kg)
Material	Carbon Steel	Carbon Steel
IMPA/ISSA code	734554	734555
	735564	735565

PIBCV Valve Flow Ranges: 1/2" to 2"

Table 23. 1/2 to 2" Valve Flow Ranges (Q_{min} to Q_{nom})

Flow rate (GPM)	1/2"				3/4"		1"		1 1/4"		1 1/2"	2"
Without PT Ports	VP228E-10BQLNNTA	VP228E-15BQLNNTA	VP228E-15BQSNTA	VP229E-15BQHNTA	VP228E-20BQSNTA	VP229E-20BQHNTA	VP229E-25BQSNTA	VP229E-25BQHNTA	VP229E-32BQSNTA	VP229E-32BQHNTA	-	-
With PT Ports	VP228E-10BQLA	VP228E-15BQLA	VP228E-15BQSA	-	VP228E-20BQSA	-	VP229E-25BQSA	-	VP229E-32BQSA	-	VP220E-40CQSA	VP220E-50CQSA
0.5	1	1	1									
1.0		1	1	1	1							
1.5			1	1	1	1	1					
2.0			1	1	1	1	1					
2.5				1	1	1	1	1				
3.0				1	1	1	1	1	1			
3.5				1	1	1	1	1	1	1		
4.0				1	1	1	1	1	1	1		
4.5				1	(1)	1	1	1	1	1		
5.0				1		1	1	1	1	1		
5.5				(1)		1	1	1	1	1		
6.0						1	1	1	1	1		
6.5						1	1	1	1	1		
7.0						1	1	1	1	1		
7.5						1	1	1	1	1		
8.0						(1)	(1)	1	1	1		
8.5								1	1	1		
9.0								1	1	1		
9.5								1	1	1		
10								1	1	1		
11								1	1	1		
12								1	1	1		
13								(1)	1	1	1	
14									1	1	1	
15									(1)	1	1	
16										1	1	
17										1	1	
18										(1)	1	
19										(1)	1	
20											1	
21											1	
22											1	1
23											1	1
24											1	1
25											1	1
26											1	1
27											1	1
28											1	1
29											1	1
30											1	1
31											1	1
32											1	1
33											1	1
34												1
35												1
36												1
37												1
38												1
39												1
40												1
44												1
48												1
52												1
55												1

(Q_{high} setting)
All flanged valves come standard with PT ports

PIBCV Valve Flow Ranges: 2½ to 10” Flanged

Table 24. 2½” to 10” Flanged Valve Flow Ranges (Q_{min} to Q_{nom})

Size Flow rate (GPM)	2-1/2"		3"		4"		5"		6"		8"		10"	
	VP220A-65CQS	VP220A-65CQH	VP220A-80CQS	VP220A-80CQH	VP220A-100CQS	VP220A-100CQH	VP221A-125CQS	VP221A-125CQH	VP221A-150CQS	VP221A-150CQH	VP222A-200CQS	VP222A-200CQH	VP222A-250CQS	VP222A-250CQH
35	34													
40	1													
45	1	44												
50	1	1	48											
55	1	1	1											
60	1	1	1											
65	1	1	1											
70	1	1	1	70	66									
75	1	1	1	1	1									
80	1	1	1	1	1									
85	85	1	1	1	1									
90		1	1	1	1									
95		1	1	1	1									
100		110	1	1	1	104								
120			120	1	1	1								
140				1	1	1								
160				176	165	1	158							
180						1	1							
200						1	1	194						
250						260	1	1						
300							1	1	256					
350							1	1	1	332	352			
400							395	1	1	1	1			
450								485	1	1	1	475		
500									1	1	1	1	528	
550									1	1	1	1	1	
600									640	1	1	1	1	
650										1	1	1	1	652
700										1	1	1	1	1
750										1	1	1	1	1
800										830	880	1	1	1
850												1	1	1
900												1	1	1
950												1	1	1
1000												1	1	1
1100												1188	1	1
1200													1320	1
1300														1
1400														1
1500														1
1600														1630
1700														

All flanged valves come standard with the PT ports

Specification Submittal Text

SpaceLogic PIBCV has the following specifications:

- NPS 2 and Smaller: PN 16, stainless steel components.
- NPS 2-1/2 through 10: Class 125 cast iron body per ASME B16.1-2010, Material class B per ASTM A 126-04 (2014), stainless steel components.
- Accuracy NPS ¾ and Smaller: The control valves shall accurately control the flow from 0 to 100% rated flow with a differential pressure range of 2.32 to 58 psi for low and standard flow units, 5 to 58 psi for high flow units within 5% of set flow value.
- Accuracy NPS 1 through 1-1/4: The control valves shall accurately control the flow from 0 to 100% rated flow with a differential pressure range of 2.9 to 58 psi for standard flow units, 5 to 58 psi for high flow units within 5% of set flow value.
- Accuracy NPS 1-1/2 through 4: The control valves shall accurately control the flow from 0 to 100% rated flow with a differential pressure range of 4.35 to 58 psi for standard flow units, 8.7 to 58 psi for high flow units within 5% of set flow rate.
- Accuracy NPS 5 through 10: The control valves shall accurately control the flow from 0 to 100% rated flow with a differential pressure range of 5.8 to 58 psi for standard flow units, 8.7 to 58 psi for high flow units within 5% of set flow value.
- Flow Characteristics: Linear Control, selectable to equal percentage at the proportional valve actuator.
- Field adjustable flow by means of a percentage of rated valve flow.
- Position feedback output signal integrated into all proportional actuators.
- 100% authority with modulating below 1% regardless of flow settings.
- No cartridges requiring replacement or maintenance.
- Close off ratings shall be 232 psi for all valve sizes.
- Valve control range 1:1000.

MP131-24T, 24F, 24MP Floating and Proportional Actuators

MP131 actuators are used together with automatically balanced combination valve type SmartX PIBCV for 1/2" to 1-1/4". Typical applications are temperature control and permanent automatic balancing on terminal units (fan-coils, chilled ceilings, air-handling units).

Features

- Gap detection at stem up position
- 3-point version
- Force switch-off at stem down position prevents overload of actuator and valve
- No tools required for mounting
- Maintenance-free lifetime
- Low-noise operation

Dimensions (mm)

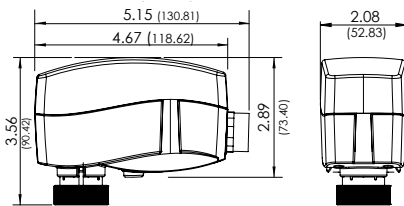

Mounting and Installation

The actuator should be mounted with the valve stem in either horizontal position or pointing upwards. The actuator is fixed to the valve body by means of a ribbed nut which requires no tools for mounting. The ribbed nut should be tightened by hand.

1. Check the valve neck. The actuator should be in stem up position (factory setting) and mounted securely on the valve body.
2. Wire the actuator according to the wiring diagram.
3. Stem movement is indicated by the Position Indicator (a small pin riding in a channel as shown in (1) below).

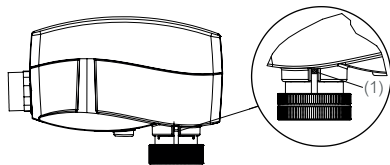

Specifications

Power supply	24 Vac/Vdc (+10-- -15%)
Power consumption	
MP131-24F/T	1.0 VA
MP131-24MP	1.5 VA, standby 0.4 W
Frequency	50/60 Hz
Control Input MP131-24MP	MP131-24MP 0-10 (2-10) V Ri = 200 Ω
Control input Y	0-20 (4-20) mA Ri = 500 Ω
Control output U	0-10 V Ro (min) = 38 kΩ
Feedback Control input Y	0-20 (4-20) mA Ri = 500 Ω
Control output X	0-10 V Ro (min) = 38 kΩ
Close off force	130 N
Stroke	5mm
Speed	50 hz: 24 s/mm 60 hz: 20 s/mm
Relative humidity	max. 95%
Max. medium temperature	248°F (120°C)
Ambient temperature	32-131°F (0-55°C)
Storage and transport temperature	-40-158°F (-40-70°C)
Protection class	IP 42
Weight	.66 lbs (0.3 kg)
Sound power level	Max. 35 dB(A)
Standards/Directives	
Heat	IEC 60068-2-2
Humidity	IEC 60068-2-3
Cold	IEC 60068-2-1
Vibration	IEC 60068-2-6

Regulatory Compliance

c-UL-us LISTED mark compliance per UL 60730-1 & -2-14 and CAN/CSA E60730-1 & -2-14. CE mark compliance per directives [2014/35/EU] LVD, [2014/30/ EU] EMC, and [2011/65/EU] RoHS2. RCM mark compliance for Australia/New Zealand community.

MP300A-SRU/SRD Multi-Signal Actuators

MP300A-SRU/SRD actuators with Floating and Proportional control are low voltage motoric actuators for the SmartX PIBCV DN10-32 (½–1¼”) Valves. These actuators have a spring return safety function that provides for an open or close valve in the event of power loss. The spring return safety function should not be used for two position control.

Features

- The advanced design incorporates load related 'switch-off' to ensure that the actuators and valves are not exposed to overload.
- The advanced design incorporates a diagnostic LED, operational data capture and self stroking feature.
- Low weight and robust.
- Spring Return operation in the event of power failure.



Dimensions (mm)

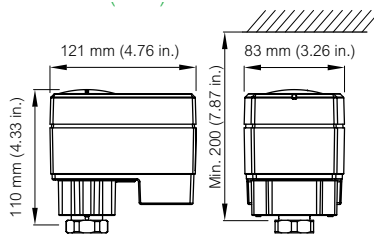

Actuator Valve Combinations

MP300A-SRU for a normally open valve. MP300A-SRD for a normally closed valve.

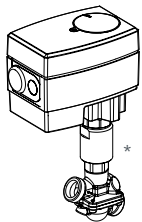

MP300-SRU +
VP228E, VP229E

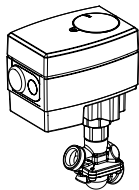

MP300-SRD +
VP228E, VP229E

Specifications

Power supply	24 Vac/Vdc (+10-- -15%)
Power consumption	9 VA
Frequency	50/60 Hz
Control input Y	0-10 (2-10) V; 0-20 (4-20) mA
Control output U	0-10 (2-10) V
Closing force	300 N
Max. stroke	5.5mm
Speed	11.75 (60 hz) s/mm 14 (50 hz) s/mm
Max. medium temperature	248 °F (120°C)
Ambient temperature	0-55°C
Storage and transport temperature	-40-158 °F (-40-70°C)
Grade of enclosure	IP 54
Weight	0.8 kg
Sound power level**	40 dB (A) ** Consideration should be given to the noise of mechanical spring return actuators in hotel guest rooms or other applications requiring silent operation.
EMC Standards/Directives	2014/30/EU EN 61000-6-2 & EN 61000-6-3 2014/35/EU EN 60730-1 & EN 60730-2-14
LVD Standards/Directives	2011/65/EU & RoHS2 Amendment 2015/863/EU
RoHS2 Directives	
UL CSA	c-UL-us LISTED using UL 60730-1 & -2 -14 and CSA/CAN E60730-1A & -2 -14

Part number	SR Direction	Linkage (incl. with actuator)
MP300A-SRU	Up - Normally Open	Adapter*
MP300A-SRD	Down - Normally Closed	Spacer

* Total height of the assembly increases with the use of the Adapter model.

MP500C, MP500C-SRU/SRD Multi-Signal Actuators

MP500C are linear electro-mechanical actuators for use with VP220x SmartX PIBCV valves, DN40–100, controlled by either an increase/decrease floating signal or by a range of modulating control signals in the range 0–10V. SRU/SRD models have a spring return feature. The U-Bolt connection allows quick and easy direct mounting onto the SmartX PIBCV VP220 valves.

Features

- Brushless DC motor.
- High resolution control board allows precise fluid control.
- Working range and end point switches adjusted automatically to the stroke of the valve.
- When driven electrically, firmware calibrates a consistent running time regardless of the valve stroke.
- During power loss SRU/SRD spring return drives the motor, generating power to the board, controlling braking speed which avoids mechanical stress and system water hammer.
- Actuators can be configured for either 3-point increase/decrease signal or various modulating control signals including sequencing.
- Stroke indicators on the yoke provide clear visual indication of the valve opening/stroke status.



MP500C-SRU/SRD



MP500C

Specifications

MP500C	Non-Spring Return
MP500C-SRU (-W)	Stem up (retract)
MP500C-SRD (-W)	Stem down (extend)
Voltage supply	24 Vac ±20% 50-60Hz 24 Vdc ±20%
Transformer Sizing	50 VA
Power consumption	
Running	30 VA (21 W)
Rest	7 W
MP500C	average 15 VA
Running Time	
Modulating	15 sec.
Increase/decrease (selectable)	60/300 sec.
Spring return	13 sec.
Stroke	2...35 mm
Force, nominal	500 N
Duty cycle	
Full load, high amb. temp.	20%/60 minutes
Half load, room temp.	80%/60 min.
Analog input Voltage range (selectable)	0...10, 2...10, 0...5, 2...6, 5...10, 6...10 Vdc
Impedance	Min. 100 k Ohm
Digital inputs, Y1, Y2	
Voltage across open input	24 Vac
Current through closed input	5 mA
Pulse time	min. 20 ms
Output, U	
Position Feedback	2...10 or 0...5 Vdc (0-100%)
Load	2 mA
Environmental	
Operation Temperature	14...122°F (-10...50 °C)
Storage Temperature	-13...149°F (-25...65 °C)
Ambient Humidity	max 90% RH (non-condensing)
Sound power level NSR	32 dBa
SR	43 dBa

Enclosure rating		
MP500C, MP500C-SRU, MP500C-SRD	IP54 (NEMA 2)	
MP500C-SRU-W, MP500C-SRD-W	IP65 (NEMA 4)	
Standards/Directives		
ElectroMagnetic Compatibility [EMC]	2014/30/EU	
Low voltage directive [LVD]	2014/35/EU	
Restriction of Hazardous Substances [RoHS2]	2011/65/EC	
Heat	IEC 60068-2-2	
Humidity	IEC 60068-2-3	
Cold	IEC 60068-2-1	
Vibration	IEC 60068-2-6	
Weight		3.2 Kg
Materials of Construction; Housing and Cover		Aluminum
Max cable core diameter		2.5 mm ²
Wiring Entry: Conduit connection	4 x M20 capped holes	
Cable gland	1 x 6..12 mm O/D, IP68	
Direct connection to Smart X PIBCV valves VP220	DN40...100	
S2 Auxillary Switch Relay (optional accessory)	SPDT, 24 Vac	
(contacts made at 5% and 95% of end stroke)	4A AC1	

Part Numbers & Accessories

Part Number	Spring Return Direction	On Power Failure	Rating
MP500C	Non-Spring Return Actuator		NEMA 2
MP500C-SRU	Spring return stem up	Valve Open	
MP500C-SRD	Spring return stem down	Valve Closed	
MP500C-SRU-W	Spring return stem up	Valve Open	NEMA 4
MP500C-SRD-W	Spring return stem down	Valve Closed	
880 0104 000	S2 aux end point switches		

MP2000A-SRU/SRD/NSR Multi-Signal Actuators

MP2000 SRU/SRD/NSR Actuators with spring return safety function and non-spring return are for fine regulation of large control valves under the demand of the HVAC controller. MP2000 SR can be controlled by either a modulating or a 3-point control signal and is used specifically with the VP221x SmartX PIBCV valves.

Features

- Manual operation mechanical and/or electrical
- Position indication, LED signalization
- Selectable speed 4 or 6 s/mm (3 or 6 s/mm NSR)
- Automatic Stroke Calibration
- Linear to EQ% Curve Adaptation
- Anti-oscillation function
- Voltage or current output signal U
- Auto detection of Y signal
- 3-point or modulating control selection
- Thermal and overload protection
- Precise regulation and fast response on floating signal (0.01 s)



Dimensions

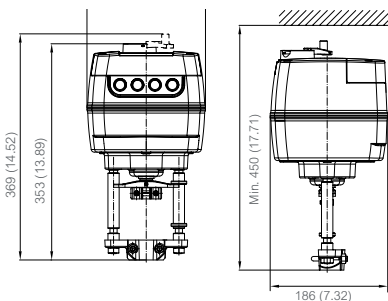

Specifications

Nominal voltage	24 Vac/Vdc, 50 Hz/60 Hz
Power consumption	15 VA (24V)
Control input signal	Modulating or 3-point floating
Power supply frequency	50/60 Hz
Control input Y	0–10 (2–10) V Ri = 40 Ω 0–20 (4–20) mA Ri = 500 Ω
Control output U	0–10 Vdc (2–10 Vdc) Ri = 10k Ω 0–20 mA (4–20 ma) Ri = 510 Ω
Force	2000 N (450 lbf)
Stroke	50mm (2")
Speed	4 s/mm or 6 s/mm
Max. medium temperature	200 °C (392°F)
Ambient temperature	0–55 °C (32–131°F)
Storage and transport temperature	-40–70 °C (-40–158°F); Storing for three days
Humidity	5–95%
Protection class	III safety extra-low voltage
Grade of enclosure	IP54, NEMA 2
Weight	8.6 kg (18.96 lbs); 6.36 kg NSR (13.8 lbs)
Safety function	Yes
Safety function runtime 50mm stroke	120 S
Manual operation	Electrical and mechanical
Power failure response	
MP2000A-SRD Safety function	stem extends down
MP2000A-SRU Safety function	stem retracts up
Standards/Directives	
Heat	IEC 60068-2-2
Humidity	IEC 60068-2-3
Cold	IEC 60068-2-1
Vibration	IEC 60068-2-6
Regulatory compliance	c-UL-us LISTED mark compliance per UL 60730-1 & -2-14 and CAN/CSA E60730-1 & -2-14. CE mark compliance per directives [2014/35/EU] LVD, [2014/30/EU] EMC, and [2011/65/EU] RoHS2. RCM mark compliance for Australia/New Zealand community.

Part number	Spring return direction
MP2000A-SRD	Stem down, extends (valve closed)
MP2000A-SRU	Stem up, retracts (valve open)
MP2000-NSR	Non-spring return

MP2000A-SRU/SRD/NSR Multi-Signal Actuators

Product Description

MP2000 SRU/SRD/NSR Actuators with spring return safety function and non-spring return are for fine regulation of large control valves under the demand of the HVAC controller. MP2000 SR can be controlled by either a modulating or a 3-point control signal and is used specifically with the VP221x SmartX PIBCV valves.

Specifications

Nominal voltage	24 Vac/Vdc, 50 Hz/60 Hz
Power consumption	15 VA (24 V)
Control input signal	Modulating or 3-point floating
Power Supply	Frequency 24 Vac/dc; +10 ... -15 %; 50/60 Hz
Control input Y	0 ... 10 V (2 ... 10 V) Ri = 40 kΩ 0 ... 20 mA (4 ... 20 mA) Ri = 500 Ω
Output U	(Position Feedback) 0 ... 10 V (2 ... 10 V) 10kΩ 0...20 mA (4...20 mA) 510 Ω
Force	
Stroke	2000 N (450 lbf)
Speed (selectable)	50 mm (2") 4 or 6 s/mm
Max. medium temperature	200°C (392°F)
Ambient temperature	0° ... + 55°C (32° ... 131°F)
Storage and transport temperature	-40° ... + 70°C (-40° ... 158°F) (storing for 3 days)
Humidity	5...95%
Protection class	III safety extra-low voltage
Grade of enclosure	IP 54, NEMA Type 2
Weight	8.6 kg (18.96 lbs) 6.26 kg NSR (13.8 lbs)
Safety function	Yes
Safety function runtime 50mm stroke	120 s
Manual operation	Electrical and Mechanical
Power failure response	MP2000A-SRD Safety function
MP2000A-SRU Safety function	Stem extends down Stem retracts up

Features

- Manual operation mechanical and/or electrical
- Position indication, LED signalization
- Selectable speed 4 or 6 s/mm (3 or 6 s/mm NSR)
- Automatic Stroke Calibration
- Linear to EQ% Curve Adaptation
- Anti-oscillation function
- Voltage or current output signal U
- Auto detection of Y signal
- 3-point or modulating control selection
- Thermal and overload protection
- Precise regulation and fast response on floating signal (0.01s)

Standards/Directives

Heat
Humidity
Cold

Vibration

IEC 60068-2-2
IEC 60068-2-3
IEC 60068-2-1
IEC 60068-2-6

Regulatory Compliance

c-UL-us LISTED mark compliance per UL 60730-1 & -2-14 and CAN/CSA E60730-1 & -2-14. CE mark compliance per directives [2014/35/EU] LVD, [2014/30/EU] EMC, and [2011/65/EU] RoHS2. RCM mark compliance for Australia/New Zealand community.

Part Numbers

Part No.

Spring Return Direction

MP2000A-SRD

Stem down, extends (valve closed)

MP2000A-SRU

Stem up, retracts (valve open)

MP2000-NSR

Non-Spring Return

Dimensions

mm (inch)

MP4000A Multi-Signal Actuator for VP222x SmartX PIBCV, DN200...250 (8...10")

The MP4000A Actuator is primarily designed to regulate valves in response to the demand of a controller in HVAC systems. MP4000A can be controlled by electronic controllers with modulating or 3-point control output.

Features

- Manual operation mechanical and/or electrical
- Position indication, LED signalization
- Selectable speed 3 s/mm or 6 s/mm
- Automatic adaptation of stroke to valve's end positions that reduces commissioning time (self-stroking)
- Integrated external switch
- Characteristic optimization
- Adjustable stroke limitation
- Anti-oscillation function
- Pulse or continuous output signal (K2, K4)
- Voltage or current output signal U
- External reset button
- Auto detection of Y signal
- 3-point floating or modulating control selection
- Galvanic isolation Y, U and output terminal K2, K4
- Thermic and overload protection
- Precise regulation and fast response on 3-point signal (0.01 s)



Specifications

Power supply	24 Vac/Vdc (+10– -15%)
Power consumption	15 VA (24V)
Frequency	50/60 Hz
Control input Y	0–10 (2-10) V Ri = 100 Ω 0–20 (4-20) mA Ri = 500 Ω
Control output U	0–10 Vdc (2–10 Vdc) Ri = 2k Ω 0–20 mA (4–20 ma) Ri = 500 Ω
Close off force	4000 N (899.23)
Max. stroke	80mm
Speed	3 s/mm or 6 s/mm
Max. medium temperature	200°C (392°F)
Ambient temperature	0–55°C (32–131°F)
Storage and transport temperature	-40–70°C (-40–158°F) Storing for three days
Humidity	5–95%
Protection class	II
Grade of enclosure	IP54, NEMA 2
Electrical connection	Conduit
Weight	7.5 (16.53 lbs)
Manual operation	Electrical and mechanical
Power failure response	Steam remains in last position
Standards	
Heat	IEC 60068-2-2
Humidity	IEC 60068-2-3
Cold	IEC 60068-2-1
Vibration	IEC 60068-2-6
Regulatory standards	c-UL-us LISTED mark compliance per UL 60730-1 & -2-14 and CAN/CSA E60730-1 & -2-14. CE mark compliance per directives [2014/35/EU] LVD, [2014/30/EU] EMC, and [2011/65/EU] RoHS2. RCM mark compliance for Australia/New Zealand community.

SP90 Multi-Function Actuator High Accuracy Multi-Function Field Bus Actuators

Product Description

Schneider Electric SpaceLogic SP90A PIBCV Actuators are high accuracy multi-function field bus actuators, specifically designed for use in combination with SpaceLogic PIBCV in sizes from DN 10...32 (3/8"...1¼") (not available in all regions). The SpaceLogic SP90A Actuator will control hot or chilled water for numerous HVAC equipment.

The high positional accuracy of the actuator, together with the accurate linear flow characteristic of the pressure independent SpaceLogic PIBCV valve, allow the SP90A Actuator to be used as a flow indicator. When the SP90A Actuator is connected to temperature sensors across a coil, the heat consumption will also be calculated.

Due to its fine accuracy, high functionality and field bus connectivity, this intelligent device combined with Schneider Electric EcoStruXure platform provides powerful engineering efficiency in the install and commissioning process.

Features

- Remote commissioning/Pre-set/Flush features
- Flow indication
- LED status
- Auto MAC addressing for and intrinsic alarm reporting for BACnet
- Auto baud rate detection
- Valve blockage alarm
- Broken wire detection on analog control and ground signal
- Mis-wiring protection on any wire up to 30 V
- BACnet MS/TP and Modbus RTU in the same product



Specifications

Power supply range	24 V ac/dc, ± 25%, 50/60 Hz
Power consumption	Running: 3.9 VA Standby: 0.9 W
Protection class	III safety extra-low voltage
Electrical connection	Pre-molded plug connector
Control signals	BACnet MS/TP, Modbus 0 to 10Vdc, 4 to 20 mA
Actuator speed selections (sec/mm)	3, 6, 12, 24, Constant Time
Stroke	7 mm
Force	90 N
Positional accuracy	± 0.05 mm
Accuracy, calculated energy usage	+/- 10%
Working ambient temp.	-10° C to 50° C
Max. medium temp.	120° C
Storage temp. range	-40 to 70° C
Sound power level	Max. 30 dB(A)
Enclosure rating	IP54 (IP40 upside-down)
Weight	0.4 kg (0.88 lb)

Cable accessories

Type	Length (m)	Connections	Part number
Digital	1.5	bus/power	9114401500
	10.0	bus/power	9114410000
Daisy chain	0.5	actuator/actuator	9114500500
	1.5		9114501500
	5.0		9114505000
	10.0		9114510000
Analogue + I/O	1.5	Actuator/free wires	9114601500
Energy		PT1000 surface mount temp sensors	9114701500
		PT1000 Immersed temp sensors	9114801500

Note: Cables are not included with actuators and must be ordered separately

Part number	Description
SP90A-24BMM	Fieldbus PIBCV Actuator

Accessory Pockets/Wells for Insertion Probe Sensors

Description	Brass Part no.	Stainless steel part no.
Immersion pocket, 50 mm, G1/2	9121040000	9121050000
Immersion pocket, 100 mm, G1/2	9121041000	9121051000
Immersion pocket, 150 mm, G1/2	9121042000	9121052000
Immersion pocket, 200 mm, G1/2	9121043000	9121053000

Note: 2 x Immersion Pockets/Wells required per device

Modbus RTU Data

Supported baud rates	Auto baud rate detection/9600 bps/19200 bps/38400 bps/56700 bps/76800 bps/115200bps
Supported transmission modes	Parity: None (1-8-N-2)/Odd (1-8-O-1)/Even (1-8-E-1)/None (1-8-N-1) Data format: Parity (Start bit - Data bits - Parity - Stop bits)

BACnet data

BACnet device profile	DZR M
BACnet protocol	BACnet Master Slave/Token Passing (MS/TP)
BACnet baud rates supported	Auto baud rate detection/9600 bps/19200 bps/38400 bps/56700 bps/76800 bps/115200bps

SP90 Multi-Function Actuator

Dimensions

Threaded Valves 1/2 to 1 1/4" (inches).

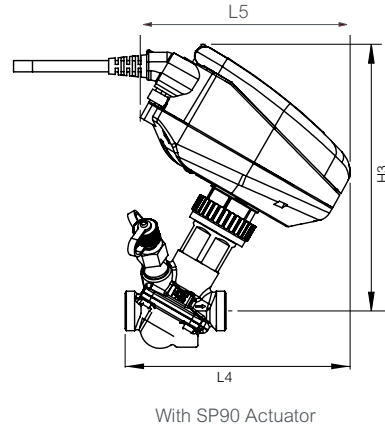
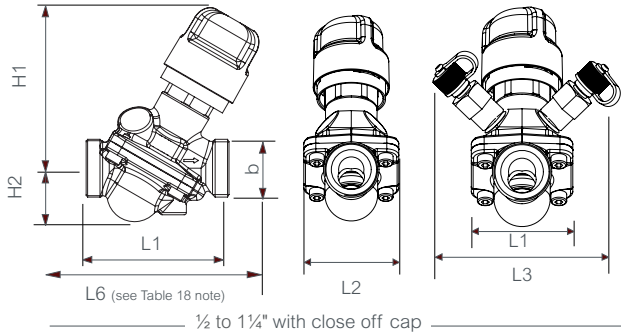

Table 8. Threaded Valves 1/2 to 1 1/4" (inches)

Type	L1	L2	L3 (PLUGS)	L4	L5	H1	H2	H3	b ISO 228/1	Valve Body Weight (lb.)
				SP90	SP90			SP90		
1/2" VP228E- 10Lx	2	1.41	3.11	4.65	4.33	2.9	.78	5.6	G 1/2	.83
1/2"	2.5	1.7		4.92		3	1	5.7	G 3/4	1
3/4"	3.2	2.2		5.24		3	1.2	5.8	G 1	1.43
1"	4	2.7		5.83		3.5	1.5	6.14	G 1 1/4	3.2
1 1/4"	5.1	3.5		6.54		3.9	2.3	6.58	G 1 1/2	4.8

Note: Valve Body Tail Piece Dimensions: See Columns A and B in "Table 17. Selection: 1/2" to 2" Valve Body Tail Pieces**" on page 80.
For assemblies with Female NPT: L6= (2x Column A - 2x Column B) +L1

Globe Valves and Actuators

Designed to provide accurate fluid control in the most demanding applications, **SpaceLogic** Globe Valves and Actuators help reduce operating costs and optimize installation and maintenance procedures.

Select from threaded or flanged variants, as well as brass or stainless-steel trim options. Multi-signal actuators that connect to a Building Management System (BMS) provide even greater flexibility.



Overview VB-7000 Series Globe Valves

2-Way and 3-Way Globe Valves

The Venta VB-7200 Series ½" to 2" 2-way globe valves feature the industry's most high-performing, energy-efficient control valves for chilled water, hot water, and steam applications. The Venta VB-7300 Series ½" to 2" 3-way globe valves provide efficient control for chilled and hot water applications. Units have a patented precision plug for high rangeability, providing efficient heat transfer over a broad range of HVAC applications. The Venta seal design provides tight close-off to ensure energy efficiency and provides a high tolerance to high differential pressures.

Venta globe valves are used for Two-position, floating, or proportional control applications. Valve assemblies may be purchased from the factory or purchased separately, requiring a linked actuator.

Features

- High rangeability provides fine, accurate control for more efficient, responsive, and comfortable regulation.
- Tight sealing with ultra-low energy leakage on shutoff for energy conservation with soft seating
- High differential-pressure rating of up to 87 psi for reliable operation in demanding applications
- Very low Cv models (as low as 0.1) for precise control of small and light-load applications
- Multiple Cv and fitting choices to match loads and piping
- RoHS compliant product is environmentally friendly and meets ANSI, PED, CRN and other standards.
- Stroke positions are suitable for all Schneider Electric actuators.
- Stem strength exceeds:
 - 600 lb. force on 2-way and mixing valves
 - 300 lb. force on diverting valves



DANGER: Do not use these valves for combustible gas applications. They are not rated for combustible applications; use in these applications could result in gas leaks and explosions.

More information

[E-26752](#)

Valve Size	VB-7000 (2-way NC, 2-way NO, 3-way mixing, 3-way diverting)	VB-8xxx (2-way NC, 2-way NO, 3-way Diverting/mixing)	VB-9313 (3-way mixing)
1/2"	•		
3/4"	•		
1"	•		
1-1/4"	•		
1-1/2"	•		
2"	•		
2½"		•	•
3"		•	•
4"		•	•
5"		•	•
6"		•	•



Venta VB-7200 Series
2-way globe valves



Venta VB-7300 Series
3-way globe valves

Ordering VB-7000 Series Globe Valves

To determine the valve actuator assembly part number, specify the following six part number fields.

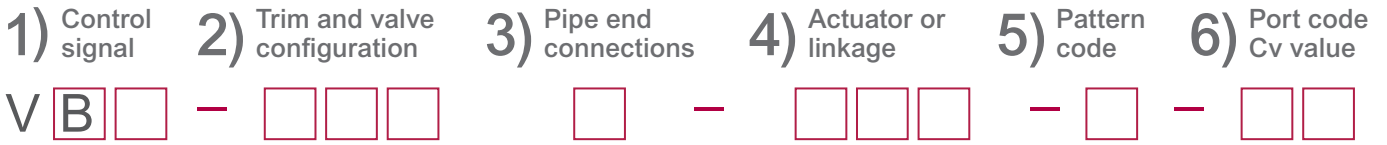

Refer to the guide below.

For water, steam, glycol and similar non flammable, non toxic fluids, choose based on the valve size and selection chart on page 95.

Ordering VB-7000 Series Valves

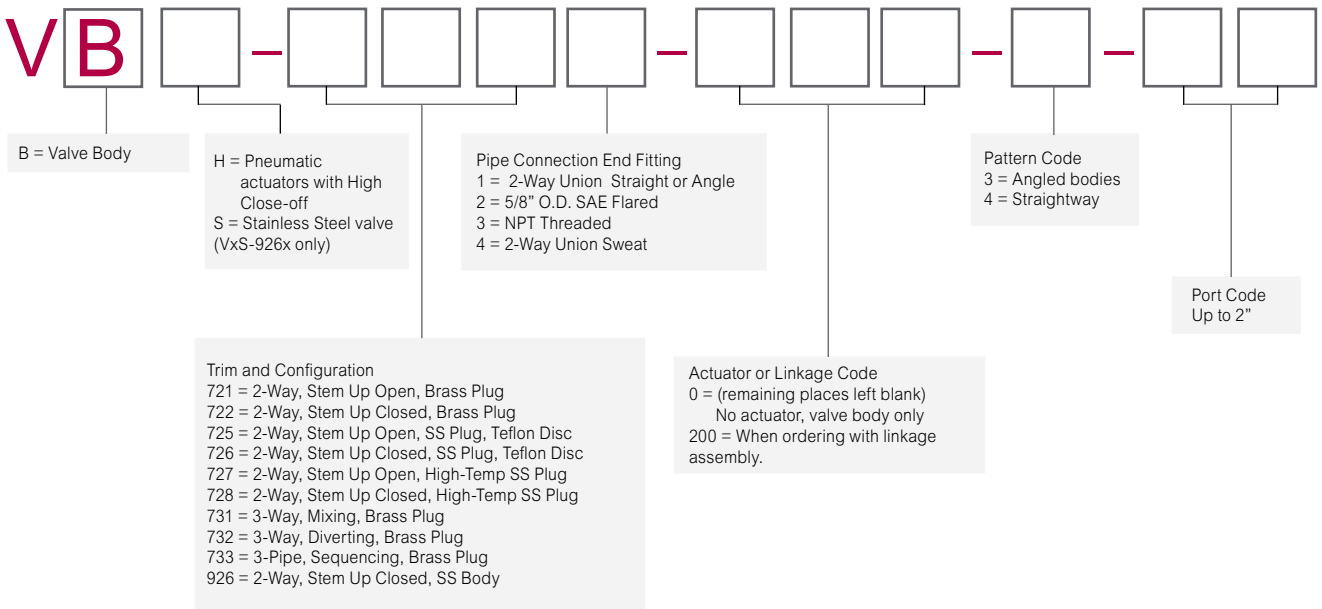

2-Way Brass Trim Valves with Soft Seats

2-Way Brass Trim

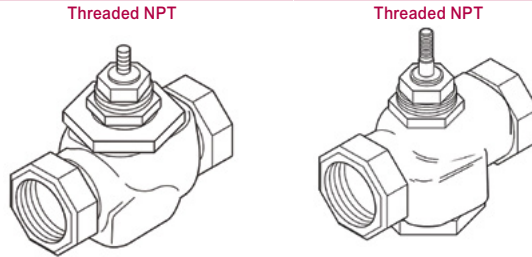

Series part number	VB-7213-0-4-	VB-7223-0-4-
Pipe sizes	½" to 2"	
Stem action	Up open	Up closed
ANSI pressure class	250 psi (up to 400 psi below 150°F)	
ANSI seat leakage ^c	Designed to ANSI V with ANSI IV above 35 psi (241 kPa) close off. Long term seat leakage dependent on proper water conditioning maintenance of the system	
Control media and temperature	20 to 281°F (-7 to 138°C) water (up to 60% glycol/water solution), low pressure, saturated, treated steam	
Flow curve	Modified equal percentage	
Allowable ΔP for water ^b	87 psi (600 kPa) Max. for normal life ^a	
Max. inlet pressure, saturated steam	35 psi (240 kPa)	
Max ΔP for sizing, saturated steam ^b	80% of inlet pressure up to 15 psig and 42% of absolute (gage pressure plus 14.7) inlet pressure above 15 psig inlet	
Max ΔP at close-off, saturated steam ^b	Inlet pressure (35 psi) (actuator must be rated to provide close-off pressure)	

Size	Cv	Kvs	Rangeability greater than	Valve body part numbers	
½"	0.4	0.3	100:1	VB-7213-0-4-01	VB-7223-0-4-01
	1.3	1.1		VB-7213-0-4-02	VB-7223-0-4-02
	2.2	1.9		VB-7213-0-4-03	VB-7223-0-4-03
	4.4	3.8		VB-7213-0-4-04	VB-7223-0-4-04
¾"	5.5	4.8		VB-7213-0-4-05	VB-7223-0-4-05
	7.5	6.5		VB-7213-0-4-06	VB-7223-0-4-06
1"	10	8.7		VB-7213-0-4-07	VB-7223-0-4-07
	14	12.1		VB-7213-0-4-08	VB-7223-0-4-08
1¼"	20	17.3		VB-7213-0-4-09	VB-7223-0-4-09
1½"	28	24.2		VB-7213-0-4-10	VB-7223-0-4-10
2"	40	34.6		VB-7213-0-4-11	VB-7223-0-4-11

a - To minimize noise, ensure the flow rate in the piping is less than 10 ft (3m) / second and the differential pressure is less than 35 psi (241 kPa). Operating with differential pressures above 35 psi may result in additional noise but is acceptable up to 87 psi (600 kPa). Operating within the cavitation zone may result in noise and internal valve damage.
 b - Maximum recommended differential pressure in open position. Do not exceed recommended differential pressure (pressure drop), as integrity of parts may be affected.
 c - Refer to Seat Leakage Classes table.

2-Way Stainless Trim Valves with Soft Seats

Threaded NPT

2-Way Stainless Trim
(soft seats)

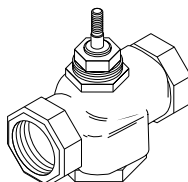

Series part number	VB-7253-0-4-		VB-7263-0-4-
Pipe sizes	½" to 2"		½" to 2"
Stem action	Up open		Up closed
ANSI pressure class	250 psi (up to 400 psi below 150°F)		
ANSI seat leakage^c	Designed to ANSI V with ANSI IV above 35 psi (241 kPa) close off. Long term seat leakage dependent on proper water conditioning maintenance of the system.		
Control media and temperature	20 to 340°F (-7 to 171°C) water (up to 60% glycol/water solution), low pressure, treated steam		
Flow curve	Modified Linear		
Allowable ΔP for water^b	87 psi (600 kPa) Max. for normal life ^a		
Max. inlet pressure, saturated steam	100 psi (690 kPa)		
Max ΔP for sizing, saturated steam^b	80% of inlet pressure up to 15 psig and 42% of absolute (gauge pressure plus 14.7) inlet pressure above 15 psig inlet		
Max ΔP at close-off, saturated steam^b	Inlet pressure (100 psi) (actuator must be rated to provide close-off pressure)		
Size	Cv	Kvs	Rangeability greater than
½"	0.1	0.09	13:1
	0.22	0.2	18:1
	0.4	0.3	100:1
	0.75	0.6	
	1.0	0.9	
	1.3	1.1	
	1.8	1.6	
	2.2	1.9	
	2.9	2.5	
	3.25	2.8	
4.4	3.8		
5.5	4.8		
¾"	6.3	5.4	
	7.5	6.5	
	8.2	7.1	
1"	9.0	7.8	
	10	8.7	
	12	10.4	
	14	12.1	
1¼"	16	13.8	
	18	15.6	
	20	17.3	
	22	19.0	
1½"	24	20.8	
	28	24.2	
	31	26.8	
2"	34	29.4	
	40	34.6	
Valve body part numbers			
			-
			VB-7263-0-4-31
			-
			VB-7263-0-4-33
			VB-7253-0-4-01
			VB-7263-0-4-01
			-
			VB-7263-0-4-34
			-
			VB-7263-0-4-36
			VB-7253-0-4-02
			VB-7263-0-4-02
			-
			VB-7263-0-4-28
			VB-7253-0-4-03
			VB-7263-0-4-03
			-
			VB-7263-0-4-30
			-
			VB-7263-0-4-39
			VB-7253-0-4-04
			VB-7263-0-4-04
			VB-7253-0-4-05
			VB-7263-0-4-05
			-
			VB-7263-0-4-41
			VB-7253-0-4-06
			VB-7263-0-4-06
			-
			VB-7263-0-4-51
			-
			VB-7263-0-4-52
			VB-7253-0-4-07
			VB-7263-0-4-07
			VB-7253-0-4-08
			VB-7263-0-4-08
			-
			VB-7263-0-4-61
			-
			VB-7263-0-4-62
			-
			VB-7263-0-4-63
			VB-7253-0-4-09
			VB-7263-0-4-09
			-
			VB-7263-0-4-71
			-
			VB-7263-0-4-72
			VB-7253-0-4-10
			VB-7263-0-4-10
			-
			VB-7263-0-4-81
			-
			VB-7263-0-4-82
			VB-7253-0-4-11
			VB-7263-0-4-11

a - To minimize noise, ensure the flow rate in the piping is less than 10 ft (3m)/second and the differential pressure is less than 35 psi (241 kPa). Operating with differential pressures above 35 psi may result in additional noise but is acceptable up to 87 psi (600 kPa). Operating within the cavitation zone may result in noise and internal valve damage.

b - Maximum recommended differential pressure in open position. Do not exceed recommended differential pressure (pressure drop), as integrity of parts may be affected. Exceeding maximum recommended differential pressure voids product warranty.

c - Refer to Seat Leakage Classes table.

2-Way Stainless Trim Valves with Metal Seats Stainless Steel Trim with Metal to Metal Seats

Threaded NPT

2-Way Stainless Trim
(Metal to Metal)

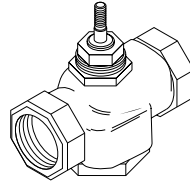

Series part number	VB-7273-0-4-		VB-7283-0-4-		
Pipe sizes	½" to 2"				
Stem action	Up open		Up closed		
ANSI pressure class	250 psi (up to 400 psig below 150°F)				
ANSI seat leakage ^c	ANSI III				
Control media and temperature	20 to 400°F (-7 to 204°C) water (up to 60% glycol/water solution), low pressure, treated steam				
Flow curve	Modified linear				
Allowable ΔP for water ^b	87 psi (600 kPa) max. for normal life ^a				
Max inlet pressure, saturated steam	150 psi (1034 kPa)				
Max ΔP for sizing, saturated steam ^b	80% of inlet pressure up to 15 psig and 42% of absolute (gauge pressure plus 14.7) inlet pressure above 15 psig inlet				
Max ΔP at close-off, saturated steam ^b	Inlet pressure (150 psi) (actuator must be rated to provide close-off pressure)				
Size	Cv	Kvs	Rangeability	Valve body part numbers	
½"	0.4	0.3	5:1	VB-7273-0-4-01	VB-7283-0-4-01
	1.3	1.1	15:1	VB-7273-0-4-02	VB-7283-0-4-02
	2.2	1.9	25:1	VB-7273-0-4-03	VB-7283-0-4-03
	4.4	3.8	40:1	VB-7273-0-4-04	VB-7283-0-4-04
¾"	5.5	4.8	50:1	VB-7273-0-4-05	VB-7283-0-4-05
	7.5	6.5	60:1	VB-7273-0-4-06	VB-7283-0-4-06
1"	10	8.7	60:1	VB-7273-0-4-07	VB-7283-0-4-07
1¼"	12	10.4	75:1	VB-7273-0-4-08	VB-7283-0-4-08
	20	17.3		VB-7273-0-4-09	VB-7283-0-4-09
	28	24.2		VB-7273-0-4-10	VB-7283-0-4-10
2"	40	34.6		VB-7273-0-4-11	VB-7283-0-4-11

a - To minimize noise, ensure the flow rate in the piping is less than 10 ft (3m) / second and the differential pressure is less than 35 psi (241 kPa). Operating with differential pressures above 35 psi may result in additional noise but is acceptable up to 87 psi (600 kPa). Operating within the cavitation zone may result in noise and internal valve damage.

b - Maximum recommended differential pressure in open position. Do not exceed recommended differential pressure (pressure drop), as integrity of parts may be affected. Exceeding maximum recommended differential pressure voids product warranty.

c - Refer to Seat Leakage Classes table.

For more information, see:

[F-26752](#)

VBS-9263 1/2" & 3/4" 2-Way Stainless Valves with Soft Seats 316 Stainless Bodies with Soft Seats

Threaded NPT - 316 Stainless Body

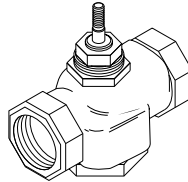

2-Way Stainless Valve and Trim with Soft Seats

Series part number	VBS-9263-0-4-xx
Pipe sizes	1/2" & 3/4"
Stem action	Up closed only
Seats	316 Stainless on PTFE
ANSI pressure class	300 psi (up to 400 psig below 150°F)
ANSI seat leakage	ANSI IV
Control media and temperature	20 to 400°F (-7 to 204°C)
Flow curve	Modified linear
Allowable ΔP for water	35 psi (241 kPa) Max. for normal lifea
Max inlet pressure, saturated steam	100 psi (690 kPa)
Max ΔP for sizing, saturated steam	80% of inlet pressure up to 15 psig and 42% of absolute (gauge pressure plus 14.7) inlet pressure above 15 psig inlet - refer to steam charts.
Max ΔP at close-off, saturated steam	Inlet pressure (100 psi) (actuator must be rated to provide close-off pressure) and withstand media temperature

Size	Cv	Kvs	Rangeability	Valve body part numbers	
1/2"	0.1	0.087	5:1	VBS-9263-0-4-31	CAUTION: Pressure reducers do not lower temperatures from boilers significantly. Select only valve actuators that withstand actual pipe temperatures near the boiler output temperature.
	0.22	0.19	5:1	VBS-9263-0-4-33	
	0.3	0.26	5:1	VBS-9263-0-4-34	
	0.4	0.3	5:1	VBS-9263-0-4-1	
	0.75	0.65	15:1	VBS-9263-0-4-35	
	0.95	0.82	15:1	VBS-9263-0-4-36	
	1.3	1.1	15:1	VBS-9263-0-4-2	
	1.75	1.5	25:1	VBS-9263-0-4-37	
	2.2	1.9	25:1	VBS-9263-0-4-3	
	2.8	2.4	35:1	VBS-9263-0-4-38	
	3.25	2.8	35:1	VBS-9263-0-4-39	
	3.6	3.0	35:1	VBS-9263-0-4-4	
3/4"	4.3	3.7	40:1	VBS-9263-0-4-45	
	5.0	4.1	40:1	VBS-9263-0-4-5	
	6.2	5.0	50:1	VBS-9263-0-4-6	

a - Operating within the cavitation zone or an operating differential pressure above 35 psi (241 kPa) may result in noise and internal valve damage.

b - Refer to Seat Leakage Classes table.

VBS-9263 1/2" & 3/4" 2-Way Stainless Valves with Soft Seats, Union Brass Trim with Soft Seats - Copper Connection

2-Way Brass Trim Body Type					5/8" OD 45° SAE Flared		Union Sweat	
Series part number					VB-7212-0-4-	VB-7222-0-4-	VB-7214-0-4-	VB-7224-0-4-
Pipe sizes					1/2" I.D.		1/2" to 2"	
Stem action					Up Open	Up Closed	Up Open	Up Closed
ANSI pressure class					250 psi (up to 400 psi below 150°F)			
ANSI seat leakage [®]					ANSI IV		Designed to ANSI V with ANSI IV above 35 psi (241 kPa) close off with long term seat leakage dependent on proper water conditioning maintenance of the system.	
Control media and temperature					20 to 281°F (-7 to 138°C) water (up to 60% glycol/water solution), low pressure, treated steam			
Flow curve					Modified Equal Percentage			
Allowable ΔP for water ^b					35 psi (241 kPa) Max. for normal life ^a		87 psi (600 kPa) Max. for normal life ^a	
Max. inlet pressure, saturated steam					35 psi (240 kPa)			
Max ΔP for sizing, saturated steam ^b					80% of inlet pressure up to 15 psig and 42% of absolute (gauge pressure plus 14.7) inlet pressure above 15 psig inlet			
Max ΔP at close-off, saturated steam ^b					Inlet pressure (actuator must be rated to provide close-off pressure)			
Size	Cv	Kvs	Rangeability ^c	Valve body part numbers				
1/2"	0.4	0.3	5:1	VB-7212-0-4-01	VB-7222-0-4-01	VB-7214-0-4-01 ^c	VB-7224-0-4-01 ^c	
	1.3	1.1	15:1	VB-7212-0-4-02	VB-7222-0-4-02	VB-7214-0-4-02 ^c	VB-7224-0-4-02 ^c	
	2.2	1.9	25:1	VB-7212-0-4-03	VB-7222-0-4-03	VB-7214-0-4-03 ^c	VB-7224-0-4-03 ^c	
	4.4	3.8	40:1	VB-7212-0-4-04	VB-7222-0-4-04	VB-7214-0-4-04 ^c	VB-7224-0-4-04 ^c	
3/4"	5.5	4.8	50:1			VB-7214-0-4-05 ^c	VB-7224-0-4-05 ^c	
	7.5	6.5	60:1			VB-7214-0-4-06 ^c	VB-7224-0-4-06 ^c	
1"	10	8.7	60:1			VB-7214-0-4-07 ^{cd}	VB-7224-0-4-07 ^{cd}	
	14	12.1	60:1			VB-7214-0-4-08 ^{cd}	VB-7224-0-4-08 ^{cd}	
1 1/4"	20	17.3	75:1			VB-7214-0-4-09 ^{cd}	VB-7224-0-4-09 ^{cd}	
1 1/2"	28	24.2	75:1			VB-7214-0-4-10 ^{cd}	VB-7224-0-4-10 ^{cd}	
2"	40	34.6	75:1			VB-7214-0-4-11 ^{cd}	VB-7224-0-4-11 ^{cd}	

a - To minimize noise, ensure the flow rate in the piping is less than 10 ft (3m) / second and the differential pressure is less than 35 psi (241 kPa). Operating with differential pressures above 35 psi may result in additional noise but is acceptable up to 87 psi (600 kPa). Operating within the cavitation zone may result in noise and internal valve damage.

b - Maximum recommended differential pressure in open position. Do not exceed recommended differential pressure (pressure drop), as integrity of parts may be affected. Exceeding maximum recommended differential pressure voids product warranty.

c - The VB-7214-0-4- and VB-7224-0-4- 1/2" to 2" series valves all have rangeabilities greater than 100:1.

d - These part numbers do not have RoHS compliant nuts and tail pieces.

e - Refer to Seat Leakage Classes table.

For more information, see:

[E-26752](#)

2-Way Brass Trim Valves with Soft Seats, Union Brass Trim Soft Seat Union for Radiators and Other Applications

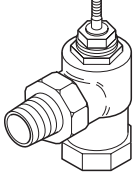
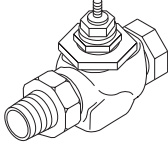
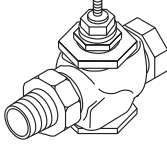
2-Way Brass Trim Body Type				Union Angle NPT	Union Straight NPT	Union Straight NPT
						
Series part number				VB-7211-0-3-	VB-7211-0-4-	VB-7221-0-4-
Pipe sizes				½" to 1¼"		
Stem action				Up Open	Up Open	Up Closed
ANSI pressure class				250 psi (up to 400 psig below 150°F)		
ANSI seat leakage ^o				Class IV	Designed to ANSI V with ANSI IV above 35 psi (241 kPa) close off with long term seat leakage dependent on proper water conditioning maintenance of the system.	
Control media and temperature				20 to 281°F (-7 to 138°C) water (up to 60% glycol/water solution), low pressure, treated steam		
Flow curve				Modified Equal Percentage		
Allowable ΔP for water ^b				35 psi (241 kPa) Max. for normal life ^a	87 psi (600 kPa) Max. for normal life ^a	
Max inlet pressure for saturated steam				35 psi (240 kPa)		
Max ΔP for sizing, saturated steam ^b				80% of inlet pressure up to 15 psig and 42% of absolute (gauge pressure plus 14.7) inlet pressure above 15 psig inlet		
Max ΔP at close-off, saturated steam ^b				Inlet pressure (35 psi) (actuator must be rated to provide close-off pressure)		
Size	Cv	Kvs	Rangeability Greater Than ^c	Valve body part numbers		
½"	0.4	0.3	5:1	VB-7211-0-3-01	VB-7211-0-4-01 ^e	VB-7221-0-4-01 ^e
	1.3	1.1	15:1	VB-7211-0-3-02	VB-7211-0-4-02 ^e	VB-7221-0-4-02 ^e
	2.2	1.9	25:1	VB-7211-0-3-03	VB-7211-0-4-03 ^e	VB-7221-0-4-03 ^e
	4.4	3.8	40:1	–	VB-7211-0-4-04 ^e	VB-7221-0-4-04 ^e
	5.0	4.3	40:1	VB-7211-0-3-04	–	–
¾"	5.5	4.8	50:1	VB-7211-0-3-05	VB-7211-0-4-05 ^e	VB-7221-0-4-05 ^e
	7.5	6.5	60:1	–	VB-7211-0-4-06 ^e	VB-7221-0-4-06 ^e
	8.5	7.4	50:1	VB-7211-0-3-06	–	–
1"	10	8.7	60:1	–	VB-7211-0-4-07 ^e	VB-7221-0-4-07 ^e
	14	12.1	60:1	VB-7211-0-3-07	VB-7211-0-4-08 ^e	VB-7221-0-4-08 ^e
	16	13.8	75:1	VB-7211-0-3-08	–	–
1¼"	20	17.3	75:1	–	VB-7211-0-4-09 ^e	VB-7221-0-4-09 ^e
	22	19	75:1	VB-7211-0-3-09	–	–

a - To minimize noise, ensure the flow rate in the piping is less than 10 ft (3m) / second and the differential pressure is less than 35 psi (241 kPa). Operating with differential pressures above 35 psi may result in additional noise but is acceptable up to 87 psi (600 kPa). Operating within the cavitation zone may result in noise and internal valve damage.

b - Maximum recommended differential pressure in open position. Do not exceed recommended differential pressure (pressure drop), as integrity of parts may be affected. Exceeding maximum recommended differential pressure voids product warranty.

c - The VB-7211-0-4-xx and VB-7221-0-4-xx series valves all have rangeabilities greater than 100:1.

e - Refer to Seat Leakage Classes table.

3-Way Valves Mixing Valves

	5/8" OD 45° SAE Flared	Threaded NPT	Union Sweat
3-Way Brass Trim Mixing Valves Body Type ^b			
Series part numbers	VB-7312-0-4-	VB-7313-0-4-	VB-7314-0-4-
Pipe size	1/2" I.D.	1/2" to 2"	
Stem flow action	Stem up closes A port and opens B port to the common AB port		
ANSI pressure class	250 psi (up to 400 psi below 150°F)		
ANSI A port seat leaked	ANSI Class III ^a	Designed to ANSI V with ANSI IV above 35 psi (241 kPa) close off with long term seat leakage dependent on proper water conditioning maintenance of the system	
ANSI B port seat leaked	ANSI Class III		
Control media and temperature	20 to 281°F (-7 to 138°C) water (up to 60% glycol/water solution)		
Water flow curve	Modified linear		
Allowable ΔP for water	35 psi (241 kPa) ^a	87 psi (600 kPa) Max. for normal life ^a	
Size	Cv	Kvs	Valve body part numbers
1/2"	2.2	1.9	VB-7312-0-4-02
	4.4	3.8	VB-7312-0-4-04
3/4"	7.5	6.5	VB-7313-0-4-06
	12	10.4	-
1"	14	12.1	VB-7313-0-4-08
	20	17.3	VB-7313-0-4-09
1 1/4"	28	24.2	VB-7313-0-4-10
2"	36	31.3	-
	41	35.5	VB-7313-0-4-11

a - To minimize noise, ensure the flow rate in the piping is less than three meters (10ft)/second and the differential pressure is less than 35 psi (241 kPa). Operating within the cavitation zone or an operating differential pressure above 35 psi (241 kPa) may result in additional noise but is acceptable up to 87 psi (600 kPa).
 b - The VB-7363-0-4- series has stainless steel trim.
 c - These part numbers do not have RoHs compliant nuts and tail pieces.
 d - Refer to Seat Leakage Classes table.

For more information, see:
 F-26752

3-Way flow patterns

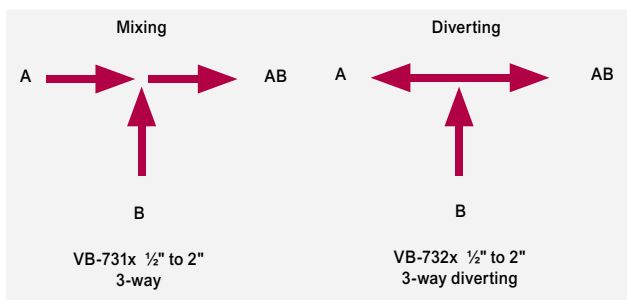

3-Way Diverting and Sequencing Valves

Diverting and Sequencing Valves

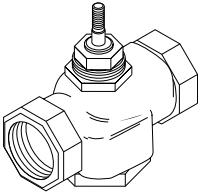
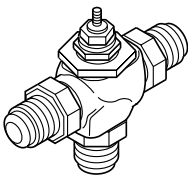
3-Way Brass Trim Diverting and Sequencing Valves Body Types			Diverting Threaded NPT		5/8" OD 45° SAE Flared Sequencing	
						
Series part numbers			VB-7323-0-4-		VB-7332-0-4-	
Pipe size			½" to 2"		½" I.D.	
Stem flow action			Stem up closes A port and opens AB port to the common B port		Stem up opens B to AB and stem down opens A to AB, stem mid position A and B are both closed	
Stem force allowed			300 Lbs.			
ANSI pressure class			250 psi (up to 400 psi below 150°F)		250 psi (up to 400 psi below 150°F)	
ANSI A port seat leakagea			ANSI Class III			
Control media and temperature			20 to 281°F (-7 to 138°C) water (up to 60% glycol/water solution)			
Water flow curve			Modified linear		Sequencing, modified linear	
Allowable ΔP for water			35 psi (241 kPa) max. for normal life			
Size	Cv	Kvs	Valve body part numbers			
½"	2.2	1.9	-		VB-7332-0-4-03	
	4.4	3.8	VB-7323-0-4-04		VB-7332-0-4-04	
¾"	7.5	6.5	VB-7323-0-4-06		-	
1"	14	12.1	VB-7323-0-4-08			
1¼"	20	17.3	VB-7323-0-4-09			
1½"	28	24.2	VB-7323-0-4-10			
2"	40	34.6	VB-7323-0-4-11			

3-Way Flow Patterns

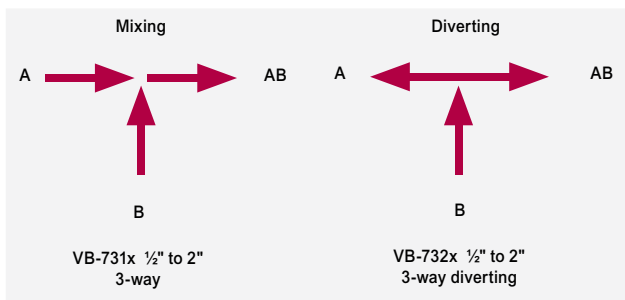

2- & 3-Way Valves Sizing for Water

Two-Position

Two-position control valves are normally selected “line size” to keep pressure drop at a minimum. If it is desirable to reduce the valve below line size, then 10% of “available pressure,” (that is, the pump pressure differential available between supply and return mains with design flow at the valve location) is normally used to select the valve.

Proportional and Floating

Proportional and floating control valves are usually selected to take a pressure drop equal to at least 50% of the available pressure. As available pressure is often difficult to calculate, the normal procedure is to select the valve using a pressure drop at least equal to the drop in the coil or other load being controlled (except where small booster pumps are used) with a minimum recommended pressure drop of 5 psi (34 kPa). When the design temperature drop is less than 60°F (33°C) for conventional heating systems, higher pressure drops across the valve are needed for good results.

Conventional Heating System

Design Temperature Load Drop °F (°C)	Recommended Pressure Drop (% of Available Pressure)	Multiplier on Load Drop
60 (33) or more	50%	1x Load Drop
40 (22)	66%	2x Load Drop
20 (11)	75%	3x Load Drop

Reducer Affects

On full flow bodies, offset the affects of directly connected reducer(s) by choosing flow coefficients 6% or more higher.

Cv (Flow coefficient) Determination

The valves' water capacity is based on the following formula:

$$Cv = \frac{GPM}{\sqrt{\Delta P}} \text{ or } Cv = \frac{GPM}{\sqrt{\frac{\text{Specific Gravity}}{\Delta P}}}$$

Where

Cv = Coefficient of flow

Cv is defined as the flow in GPM with ΔP = 1 psi with the valve completely open

GPM = U.S. gallons per minute (60°F, 15.6°C)

ΔP = Differential pressure in psi (pressure drop)

Proportional 3-Way Valves

Recommended pressure drop - bypass application: 50% of available pressure, or equal to pressure drop through the load at full flow.

3-way valves in the return used to control output by throttling water flow to the load (bypass applications) are controlling output in the same manner as throttling 2-Way valves, and must be selected using the same high pressure drops if good control results are to be obtained.

Recommended pressure drop - constant flow applications: 20% of available pressure, or equal to 1/4 of the pressure drop through the load at full flow.

3-Way valves used with individual pumps to control output by varying water temperature to the load (constant flow applications) are controlling output by mixing two water sources at different temperatures and do not require high pressure drops for good control results.

Water Capacity Graph Instructions

To select the appropriate valve Cv from the graph:

1. Select the required flow from the “Flow in GPM” axis.
2. Select available pressure drop from the “Pressure Drop in psi” axis.
3. Select the appropriate line and follow to the Capacity Cv (Kv) listing and choose the closest valve Cv flow coefficient.
4. Confirm the selection by calculation from the water equations.

Additional Water Valve Sizing Information

For more information, download these documents from our website.

- CA-27 3-Way Valves Application Information
- Valve Selection Table Water, F-11080

2-Way Flow, Temperature and Materials

Flow Characteristics

2-way valves with brass plugs have modified equal percentage flow curves and valves with stainless steel plugs have modified linear flow curves. With modified equal percentage flow curves, for equal increments of valve stem stroke, the change in flow rate with respect to valve stroke may be expressed as a constant percent of the flow rate at the time of the change. The change of flow rate with respect to valve stroke is relatively small when the valve plug is near the valve seat and relatively high when the valve plug is nearly wide open. With modified linear flow curves, the flow is directly proportional to the valve stem position.

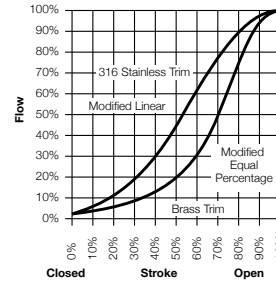

Temperature Pressure Ratings

Consult the appropriate valve linkage installation instructions for the effect of valve body ambient temperatures on specific actuators. Ratings conform to published values and disclaimer.

VB-72xx-0-4-P (Cast Bronze Body)

Standards: Pressure to ANSI B16.15 Class 250 with 400 psig up to 150° F decreasing to 321 psig at 281° F, ASTM B584

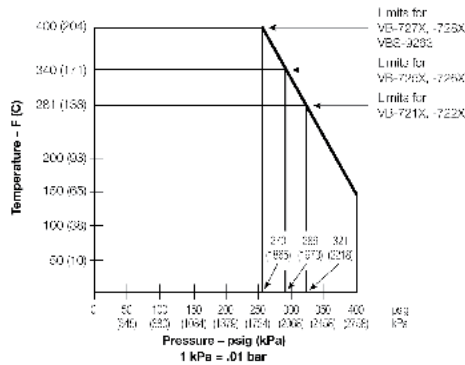

Caution: Pressure/temperature ratings are for the body only, not the piping. Consult ANSI 816.22 for ratings of solder joint fittings. The lowest piping component ratings are the high limit.

VB-7200 2-Way Globe Valves Material Specifications

VB-7200 Valve Series to	VB-7211-0-4 (½" to 1¼"), VB-7213, VB-7221-0-4 (½" to 1¼"), VB-7223, VB-7214, VB-7224	VB-7211-0-3 (½" to 1¼"), VB-7212 (½"), VB-7222 (½")		VB-7253, VB-7263	VB-7273, VB-7283	VBS-9263
Body	Bronze, ASTM B584					316 SS
Seat	Bronze, ASTM B584			316 stainless steel		
Stem	316 stainless steel					
Plug	Brass			316 stainless steel		
Packing	Spring-loaded PTFE/EPDM					PTFE
Seal	½" & ¾"	PTFE	EPDM	PTFE	Metal to metal 316 stainless steel	PTFE
	1" to 2"	EPDM				

Packing and Seal materials: Polytetrafluoroethylene (PTFE), ethylene propylene diene monomer (EPDM).

Water Capacity for 0.1 to 9.0 Cv valves

Water Capacity for 0.1 to 9.0 Cv valves

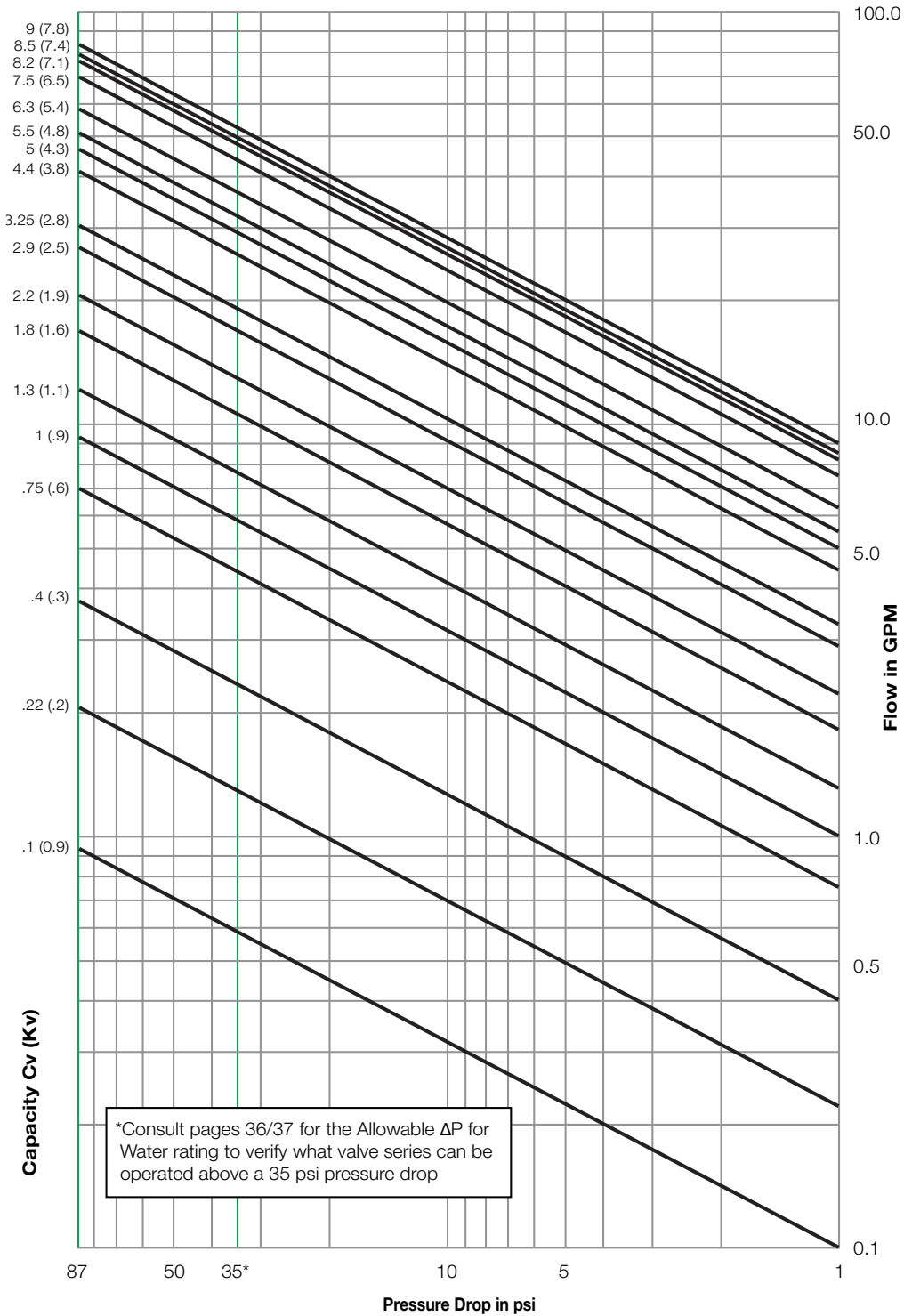

1 GPM = .06309 l/s = .22712 cubic m/h

Water Capacity for 10 to 40 Cv Valves

Water Capacity for 10 to 40 Cv Valves

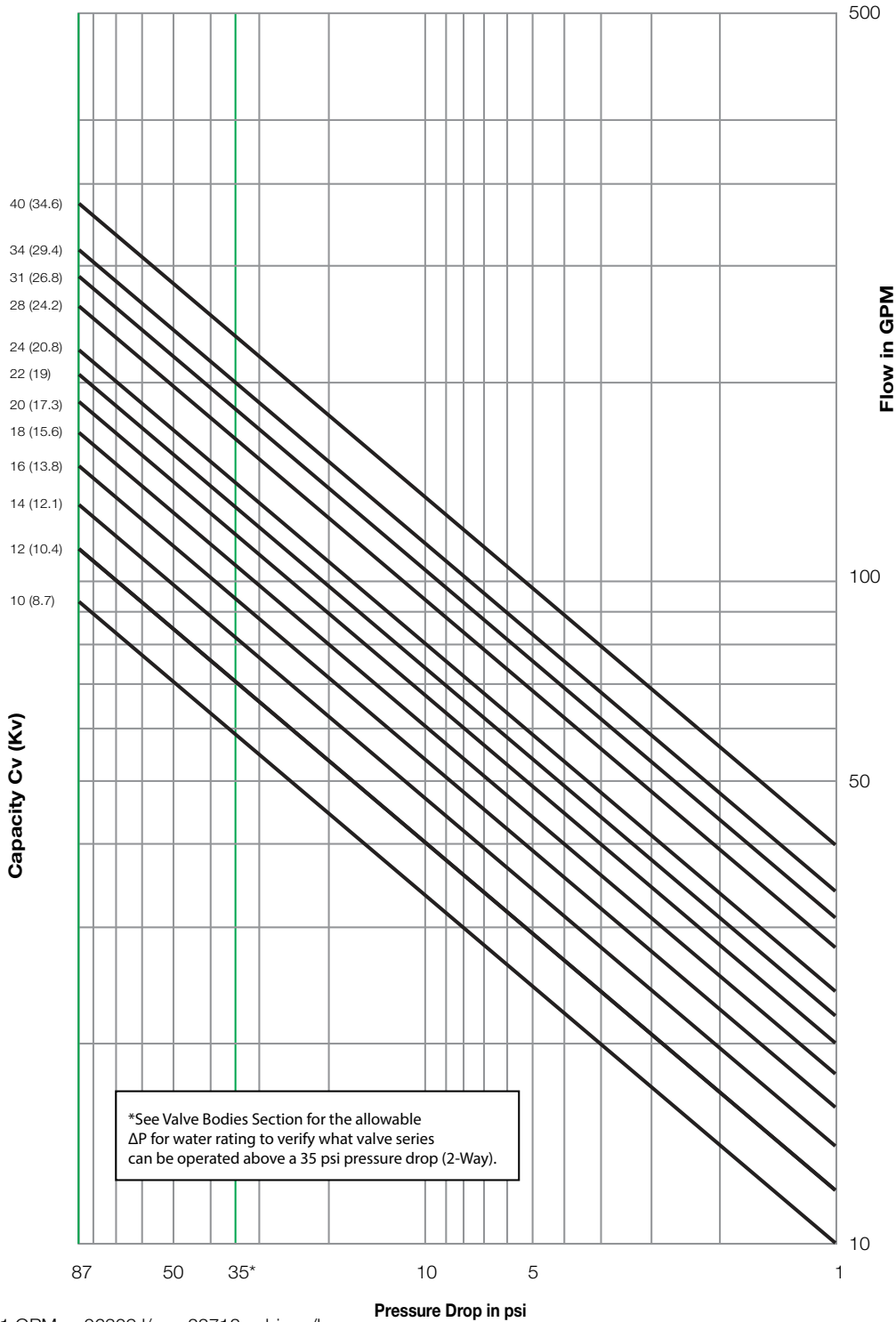

3-Way Flow, Temperature and Materials

Flow Characteristics

3-Way valves are designed so that the flow from inlet ports, (A and B), to the outlet port (AB) is modified linear.

3-Way diverting valves are designed so that the flow from the inlet port (B) to the outlet ports (A and AB) is modified linear.

Sequencing valves have both ports (A and B) closed off in the center of stroke and have modified linear flow for each port as it opens to supply it's coil.

Rangeability is greater than 100:1 for both the A and B ports.

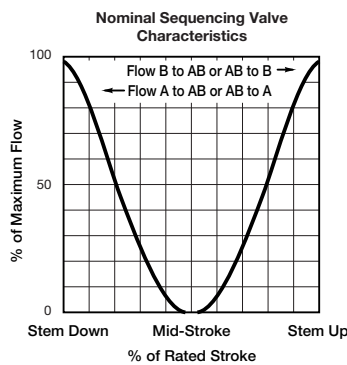
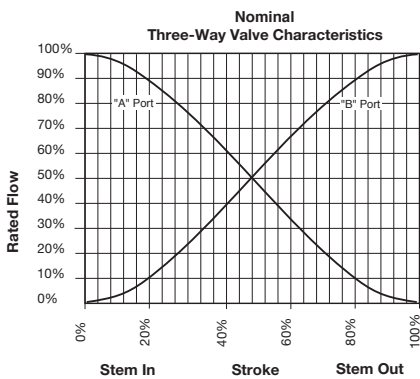

Temperature Pressure Ratings

Consult the appropriate valve linkage installation instructions for the effect of valve body ambient temperatures on specific actuators. Ratings conform to published values and disclaimer:
 VB-72xx-0-4-P (Cast Bronze Body)
 Standards: Pressure to ANSI B16.15 Class 250 with 400 psig up to 150° F decreasing to 321 psig at 281° F, ASTM B584

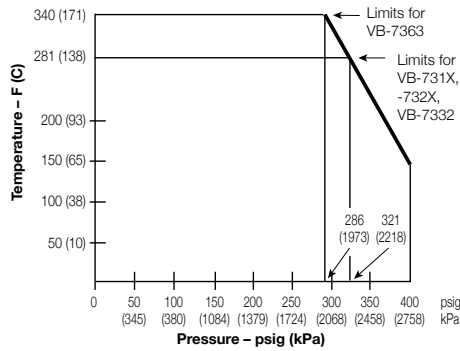

Caution: Pressure/temperature ratings are for the body only, not the piping. Consult ANSI 816.22 for ratings of solder joint fittings. The lowest piping component ratings are the high limit.

VB-7300 3-Way Globe Valves Material Specifications

Material	VB-7313, VB-7314	VB-7312, VB-7332, VB-7323	VB-7363
Body	Bronze ASTM, B584		
A port seat	Brass		316 stainless steel
B port seat	Bronze ASTM, B584		
Stem	316 stainless steel		
Plug	Brass		316 stainless steel
Packing	Spring-Loaded PTFE/EPDM		
A port seal	½" and ¾"	PTFE	PTFE
	1" to 2"	EPDM	
B port seal	½" and ¾"	Metal to metal	Metal to metal 316 stainless steel
	1" to 2"		

Packing and Seal materials: Polytetrafluoroethylene (PTFE), ethylene propylene diene monomer (EPDM)

Water Capacity

Water Capacity

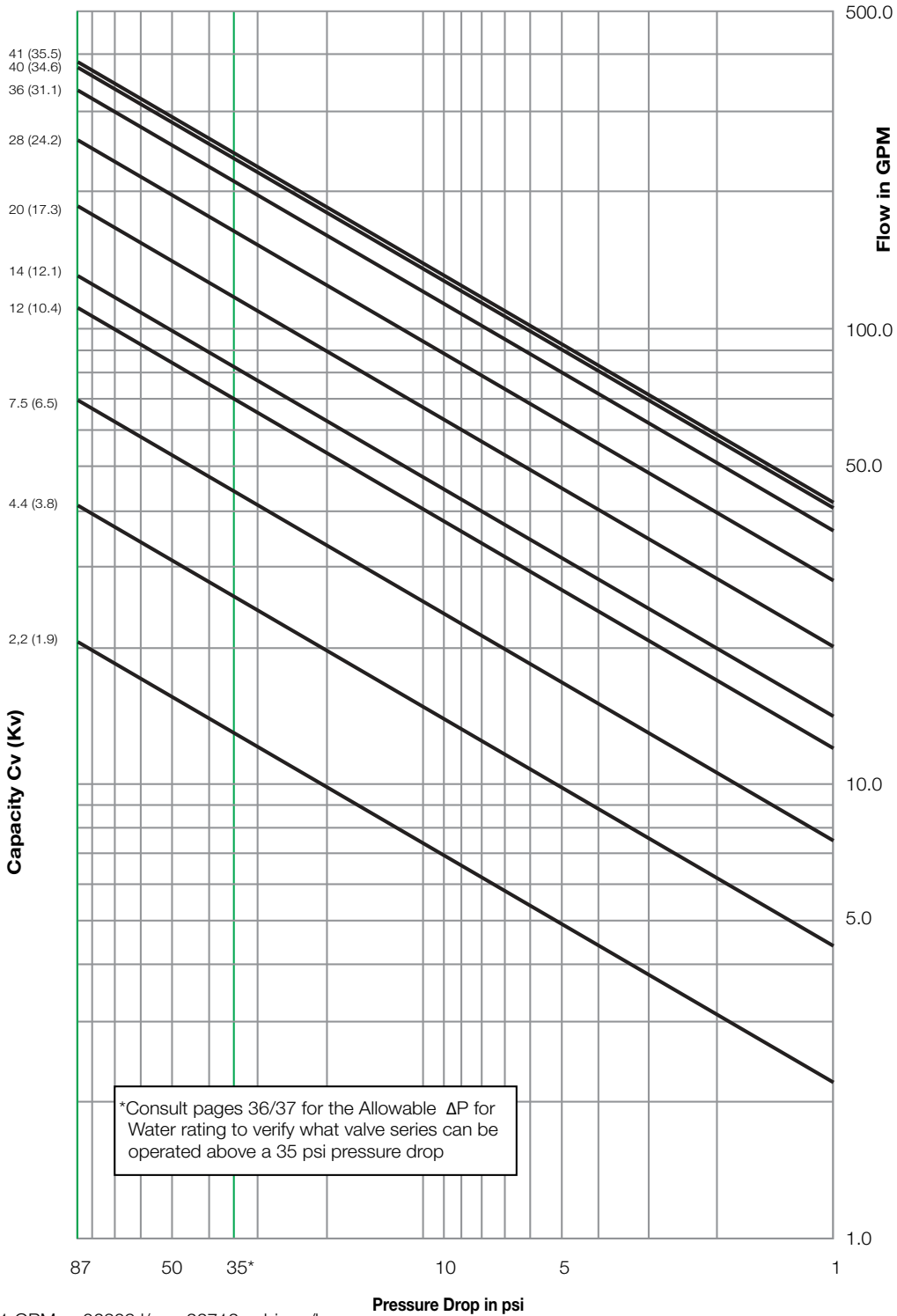

1 GPM = .06309 l/s = .22712 cubic m/h

Cavitation Limitations on Valve Pressure Drop

A valve selected with too high a pressure drop can cause erosion of seals and/or wire drawing of the seat. In addition, can cause noise, damage to the valve trim (and possibly the body), and choke the flow.

Do not exceed the maximum differential pressure (pressure drop) for the valve selected. The following formula can be used on higher temperature water systems, where cavitation could be a problem, to estimate the maximum allowable pressure drop across the valve:

$$P_m = 0.5 (P_1 - P_v)$$

Where:

- P_m = Maximum allowable pressure drop (psi)
- P₁ = Absolute inlet pressure (psia)
- P_v = Absolute vapor pressure (psia)

Note: Add 14.7 psi to gauge supply pressure to obtain absolute pressure value. For example, if a valve is controlling 200°F water at an inlet pressure of 18 psig, the maximum pressure drop allowable would be:

$$P_m = 0.5 [(18 + 14.7) - 11.53] = 10.6 \text{ psi}$$

(Vapor pressure of 200°F water is 11.53 psia)

Systems where cavitation is shown to be a problem can sometimes be adjusted to provide higher downstream back pressures. Valves having harder seat materials should be furnished if velocities are excessive.

Vapor Pressure of Water

Temp. (°F)	Pressure (psia)	Temp. (°F)	Pressure (psia)	Temp. (°F)	Pressure (psia)	Temp. (°F)	Pressure (psia)
40	0.12	90	0.70	140	2.89	190	9.34
50	0.18	100	0.95	150	3.72	200	11.53
60	0.26	110	1.28	160	4.74	210	14.12
70	0.36	120	1.69	170	5.99	220	17.19
80	0.51	130	2.22	180	7.51	230	20.78

Cavitation Limitations on Valve Pressure Drop

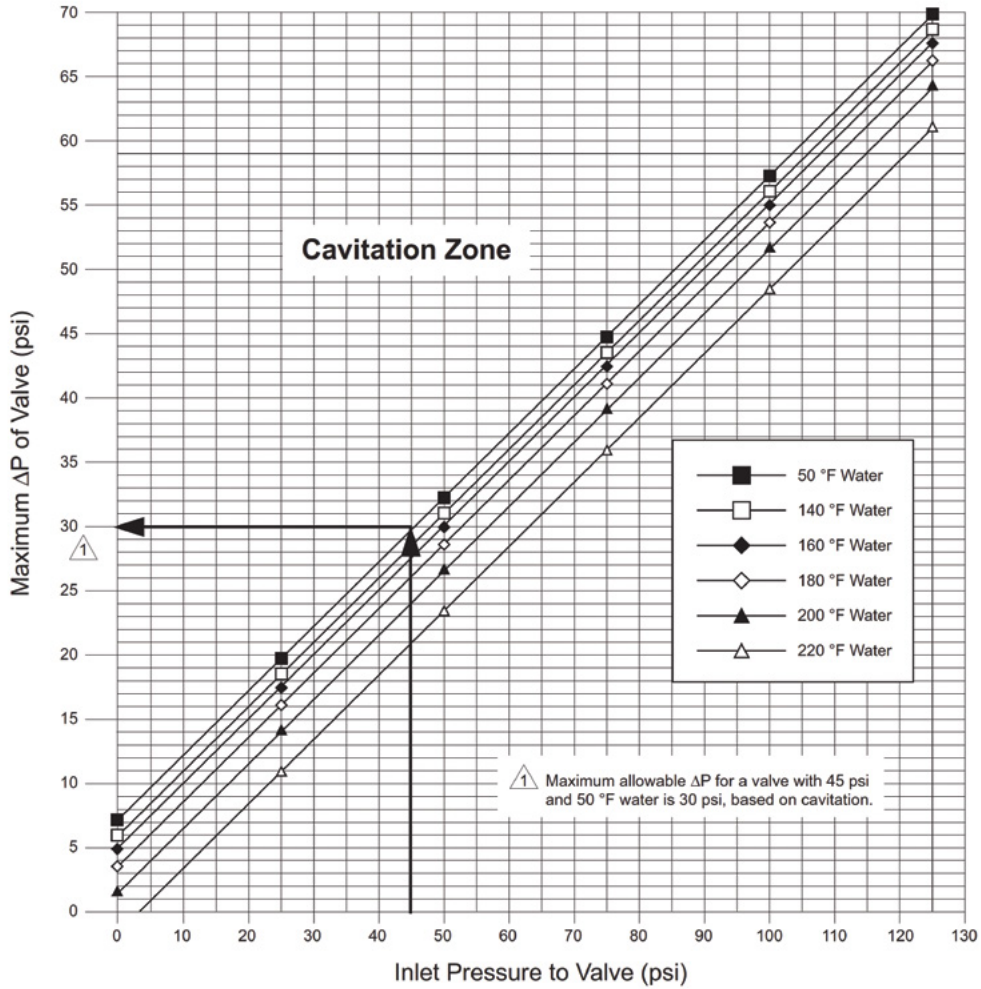

Maximum Allowable Differential Pressure (ΔP) for Water Valves.

Saturated Steam Valve Selection for 1/2" to 6" Valves (2-way only)

Selection instructions

Warning: Pressure reducers do not lower boiler temperatures significantly, resulting in superheated steam. Select only steam valves which can withstand temperatures near the original boiler temperature.

Caution: Do not size a steam valve with a pressure drop greater than 42% of the absolute pressure.

Actuator must be rated to provide adequate Close off pressure.

Two-position control: Unless otherwise specified, select line-size, 2-Way valves, stem-up open or closed and are normally sized using a minimum of 10% of inlet pressure (psig).

Proportional

1. Go to rows which are nearest to minimum pounds/hour flow required.
2. Go to columns nearest to the assured supply pressure.
3. Note Cv values at the column/row intersection.
4. Select the listed valve Cv which provides adequate flow.
5. If reducers are used, expect flow to be reduced as much as 15%.

Reference

For further information, download CA-28 Control valve sizing, F-13755, from iPortal.

The following is the terminology and the equations for the table above:

“Low Pressure” steam (Up to 15 psig.)

$$Cv = Q / (2.1 \times (\Delta P \times (P_1 + P_2))^{0.5})$$

“High Pressure” steam (Above 15 psig.)

$$Cv = Q / (1.38 \times P_{1abs})$$

Cv =

Flow Coefficient

ΔP = Differential pressure in psi (pressure drop)

Q =

Lbs. per hour of steam

P_2 = Outlet pressure in psia (absolute)

psig + 14.7 = psia (absolute)

K = 1 + (0.0007 x °F super-heat)

Saturated Steam Valve Selection

Dp (psi.)	2	5	10	15	25	35	50	75	100
	“Low Pressure Steam”				“High Pressure Steam”				
Lb/Hour	Select proportional valve Cv close to chart value.								
2	0.16	0.15	0.13	0.12	0.04	0.03	0.02	0.02	0.01
3	0.24	0.23	0.20	0.18	0.05	0.04	0.03	0.02	0.02
5	0.41	0.38	0.34	0.31	0.09	0.07	0.06	0.04	0.03
8	0.65	0.60	0.54	0.49	0.15	0.12	0.09	0.06	0.05
11	0.90	0.83	0.74	0.67	0.20	0.16	0.12	0.09	0.07
16	1.3	1.2	1.1	1.0	0.29	0.23	0.18	0.13	0.10
24	2.0	1.8	1.6	1.5	0.44	0.35	0.27	0.19	0.15
35	2.9	2.6	2.3	2.1	0.64	0.51	0.39	0.28	0.22
50	4.1	3.8	3.4	3.1	0.91	0.73	0.56	0.40	0.32
74	6.0	5.6	5.0	4.5	1.4	1.1	0.83	0.60	0.47
109	8.9	8.2	7.3	6.7	2.0	1.6	1.2	0.88	0.69
160	13	12	11	10	2.9	2.3	1.8	1.3	1
240	20	18	16	15	4.4	3.5	2.7	1.9	1.5
350	29	26	23	21	6.4	5.1	3.9	2.8	2.2
500	41	38	34	31	9.1	7.3	5.6	4	3.2
750	61	56	50	46	14	11	8	6	5
1100	90	83	74	67	20	16	12	9	7
1600	131	120	107	98	29	23	18	13	10
2400	196	180	161	147	44	35	27	19	15
3500	285	263	235	214	64	51	39	28	22
5000	408	376	335	306	91	73	56	40	32
7000	571	526	469	428	128	102	78	57	44

Body Size	Cv	Port Code
1/2"	0.10	31
	0.22	33
	0.40	01
	0.75	34
	1	36
	1.3	02
	1.8	28
	2.2	03
	2.9	30
	3.25	39
3/4"	4.4	04
	5.5	05
	6.3	41
1"	7.5	06
	8.2	51
	9	52
	10	07
	12	08
1 1/2"	14	61
	16	62
	18	63
	20	09
2"	22	71
	24	72
	28	10
2 1/2"	31	81
	34	82
	40	11
3"	56	12
3"	85	13
4"	145	14
5"	240	15
6"	370	16

VB-7000 & VBS 9263 1/2" to 2" Hydraulic & Electric Close-Off

Note: The following tables offer a quick guide to valve actuator combination/close-off ratings.

2.14 Seat Leakage Classes

ANSI/FCI 70-2 Leakage Class	Maximum seat leakage
Class II	0.5% of rated Cv
Class III	0.1% of Rated Cv
Class IV	0.01% of Rated Cv
Class V	0.0005 ml per minute per inch of orifice diameter per psi differential

Close-off ratings

Nominal actuator close-off ratings range from ANSI III (metal to metal trim) to ANSI IV and ANSI V (EPDM and PTFE Discs). Refer to VB-7000 Bronze Bodies for your specific application requirements.

Note: Valve body and actuator size determine the close-off capabilities. Example: All 1/2", 2-Way globe valves will make the same close-off, regardless of the Cv rating, for a given actuator.

Electric Spring Return (SR)

VB-7000 & VBS-9263 Hydraulic & Electric Close-Off (psi)

Stem Up Open, Closed & Mixing

All are 250 psi. close-off. VB-7323 Diverting: Bottom port is common.

	MP/MPR-5200	MA-5200	M40-704x	Mx51-710x	Mx41-707x	M900Ax-VB	Mx51-720x	M41-715x	M40-717x			
Linkage	AV-7600		AV-611	None	AV-602	None		AV-602				
Actuator code	Choose code from assembly and actuator sections.											
Pipe size	Power Down Closed a,c,d	Spring Up Closed b,c,d	Power Down Closed a,c,d	Spring Up Closed b,c,d	Power or Spring							
					N.O.a	N.C.b						
1/2"	130	130	130	200	250	250	250	250	250	250	250	250
3/4"	80	80	80	130	250	200	200	250	250	250	250	250
1"	40	40	40	50	125	150	90	180	180	230	250	250
1 1/4"	25	25	25	35	75	90	60	120	110	150	200	250
1 1/2"	15	25	60	35	50	60	35	80	75	100	140	160
2"	10	14	35	20	25	32	20	40	40	65	80	120

a - Normally Open (N.O.) assembly using stem up open valve body.

b - Normally Closed (N.C.) assembly using stem up closed valve body or 3-Way A port.

c - With appropriate AV-7600 springs.

d - For 3-Way close-offs you must consider power down and spring-up close offs.

2.16 Electric Non-Spring Return (NSR)

VB-7000 & VBS-9263 Electric Close-Off (psi)

Stem Up Open, Closed & Mixing. VB-7323 Diverting: Bottom port is the common. All are 250 psi. close-off

	M400A-VB	Mx41-6043	Mx41-6083	M800A-VB	Mx41-6153	M1500-VB
Linkage	None	AV-611	AV-611	None	AV-611	None
Actuator code	Choose code from assembly and actuator sections					
Pipe size	250	225	250	250	250	250
1/2"						
3/4"	198	225	200	250	250	250
1"	92	100	130	207	250	250
1 1/4"	56	60	100	130	225	250
1 1/2"	37	40	70	88	140	177
2"	19	20	40	48	80	98

1/2" to 2" Pneumatic Close-off Ratings

Note: The following tables offer a quick guide to valve actuator combination/close-off ratings.

VB-7000 Pneumatic Close-Off Ratings (psi)

Actuator										MK-2690 (6 square inch)									
Optional positioner										AK-42309-500									
Linkage										AV-7400									
Spring range										3 to 7 psi.			5 to 10 psi.			8 to 13 psi.			
Actuator code										201			202			203			
Supply air (Psi.)										15/20	15	20	15/20	15	20	15/20	15	20	
Stem closed positiona										Up N.C.	Down	Down	Up N.C.	Down	Down	Up N.C.	Down	Down	
2-Way and mixing	1/2"										-	130	220	50	60	170	130	-	90
	3/4"										-	80	130	30	40	120	60	-	60
	1"										-	35	70	9	15	50	30	-	25
	1 1/4"										-	20	40	-	8	30	15	-	15
	1 1/2"										-	14	29	-	5	20	10	-	9
	2"										-	6	14	-	-	10	-	-	-

Diverting: bottom port as the common. Use MK-46xx below for tightest close-off.

a - In 2 or 3-Way "A" port valves, Up N.C. is normally closed in up position. Down closes a N.O. valve or 3-Way "B" port.

VB-7000 Pneumatic Close-Off Ratings (psi)

Actuator										MK-46xx (11 square inch)									
Optional Positioner										AK-42309-500									
Linkage										AV-401									
Spring Range										3 to 7 psi.			5 to 10 psi.			8 to 13 psi.			
Actuator code										301			302			303			
Supply Air (Psi.)										15/20	15	20	15/20	15	20	15/20	15	20	
Stem closed positiona										Up N.C.	Down	Down	Up N.C.	Down	Down	Up N.C.	Down	Down	
2-Way and Mixing	1/2"										30	250	250	100	120	250	250	10	200
	3/4"										20	180	250	70	80	180	160	-	120
	1"										5	90	150	30	35	100	60	-	65
	1 1/4"										-	50	90	15	20	60	40	-	40
	1 1/2"										-	30	60	10	10	40	35	-	25
	2"										-	15	30	-	-	25	15	-	10

Diverting: bottom port as the common. All sizes are balanced for 250 psi close-off.

a - In 2 or 3-Way "A" port valves, Up N.C. is normally closed in up position. Down closes a N.O. valve or 3-Way "B" port.

VB-7000 Pneumatic Close-Off Ratings (psi)

Actuator										MK-66xx (50 square inch, half inch stroke)									
Optional positioner										AK-42309-500									
Actuator and linkage										MK-6601-301			MK-6611-302			MK-6621-303			
Linkage										AV-430									
Spring range										3 to 8			5 to 10			8 to 13			
Actuator code										611			612			613			
Supply air (Psi.)										15/20	15	20	15/20	15	20	15/20	15	20	
Stem closed positiona										Up N.C.	Down	Down	Up N.C.	Down	Down	Up N.C.	Down	Down	
2-way and mixing	1 1/2"										40	170	250	80	110	230	170	40	160
	2"										20	90	160	50	60	120	90	20	90

Caution! Diverting: bottom port as common. Actuator may be too strong, use smaller actuator.

a - In 2 or 3-Way "A" port valves, Up N.C. is normally closed in up position. Down closes a N.O. valve or 3-Way "B" port.

Overview of VB-7000 1/2" to 2" Valve Actuator Assemblies

Globe Valve Assemblies

The VA, VF, and VS-7000 series Linked Globe Valve Assemblies are complete actuator/valve assemblies that accept Two-position, floating or proportional control, respectively, from a DDC system or from a thermostat, for control of hot water, chilled water and steam coils. These valve assemblies consist of linked spring return and non-spring return actuators mounted on 1/2" to 2" (15 mm to 50 mm) 2-Way and 3-Way globe valve bodies, using a specially designed linkage assembly. 3-way assemblies are available for mixing (1/2" to 2") and diverting (1/2" to 2") applications.

Typical applications include reheat on VAV boxes, fan coil units, hot and chilled water coils in air handling units, unit ventilators, and central system applications.

Kits are available separately to allow field assembly of SmartX actuators to valve bodies.

Mx4x-6xxx and Mx4x-7000 Series Spring and Non-Spring Return Actuator/Linkage Assemblies with SmartX actuators

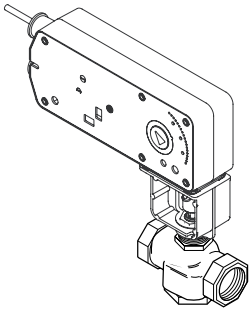

VB-73xx Series 1/2" to 2" 3-Way Assembly with SmartX Linear SR Actuators

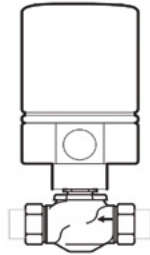

VB-72xx 2-Way Globe Valve with MA/MP/MPR-5XXX Hydraulic Actuator

Seat Leakage Classes

ANSI/FCI 70-2 leakage class	Maximum seat leakage
Class II	0.5% of rated Cv
Class III	0.1% of Rated Cv
Class IV	0.01% of Rated Cv
Class V	0.0005 ml per minute per inch of orifice diameter per psi differential

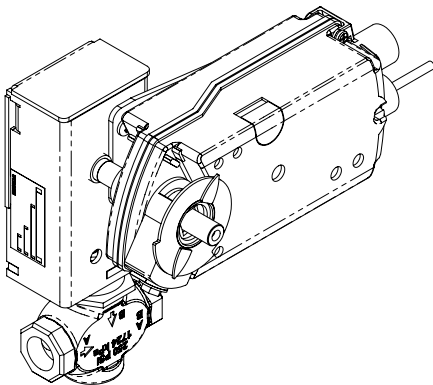

2-Way Linked Globe Valve Assembly (Non-Spring Return model shown)

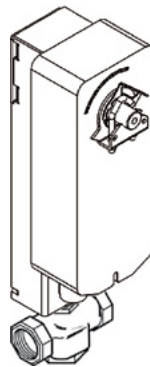

3-Way Linked Globe Valve Assembly (Spring Return Model shown)

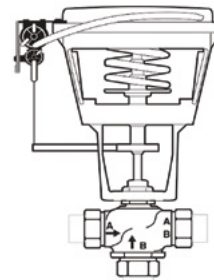

MK-66X1 with VB-7313-0-4-P VB-7314-0-4-P VB-7323-0-4-P

VB-73xx 3-Way Globe Valve with MK-66x1 Pneumatic Actuator

Globe Valve Assembly Selection Procedure

When selecting a globe valve assembly, first determine the applicable codes for the Control signal type, valve body configuration, end connection, port size and actuator according to Assembly Ordering on the pages that follow. Select a globe valve assembly part number as follows:

1. Control signal type, valve body configuration, and end connection

Refer to Assembly Ordering and select the appropriate codes for the part-number fields.

2. Valve size (flow coefficient)

If the required flow coefficient (Cv) has not been determined, do so as follows:

Refer to Sizing and Selection to calculate the required Cv.

Select the nearest available Cv value and corresponding valve body port code from Assembly Ordering.

3. Actuator and linkages

Select the appropriate actuator and code, according to Assembly Ordering on the next pages based on the Control signal type, required valve normal position, and voltage requirements.

Note: Linkages shown in Specification tables are supplied with the actuator. When shown in Optional accessories the linkage must be ordered separately.

4. Close-off pressure

Confirm, with respect to actuator close-off capacity, that the selected actuator and valve body combination provides sufficient close-off pressure. If no close-off pressure is shown, the valve body/actuator combination is not valid.

5. Available space

If available space is a consideration, check the appropriate figure in the separately available Wiring, Dimensions and Reference document F-28125 from the mySchneider download center.

Range name	Description	Family	Electric Non-Spring Return Operation				Electric Spring Return Operation			Pneumatic Spring Return Operation	
			Proportional	Floating	Pulse Width Modulated	Two Position	Proportional	Floating	Two Position	Two position	Proportional with Positive Positioner
SmartX	Originally developed by Schneider Electric in the United States under the DuraDrive brand. Upgraded in 2015 to SmartX with new features	Mx51-710x					•	•	•		
		Mx51-720x, Mx61-720x 1					•	•	•		
		MG350V	•	•	•	•					
Forta	Developed by Schneider Electric in Europe. Introduced to North America in 2008 because of its flexibility and ease of setup. 2	M400, M800, M1500		•							
		M900 (Coming soon to North America!)						•		•	3-Wire
Legacy	Earlier North American actuators developed by Schneider Electric; (Barber Colman, Siebe, Invensys). Still popular because of their value and reliability.	MK-2690, MK-4xxx, MK-6xxx, MK-8xxx								•	•
		MA-521x, MP-521x, MP-541x, MP-5513, MPR-5613						•		•	

1- The Mx51-720x, Mx61-720x actuator are higher force versions of the Mx51-710x for large valves and high close-off applications.

2- Forta actuators have universal inputs for proportional and floating operation.

Ordering VB-7000 Globe Valve Assemblies SmartX Actuators

Specify Seven Part Number Fields
to Determine the Valve Actuator Assembly Part Number

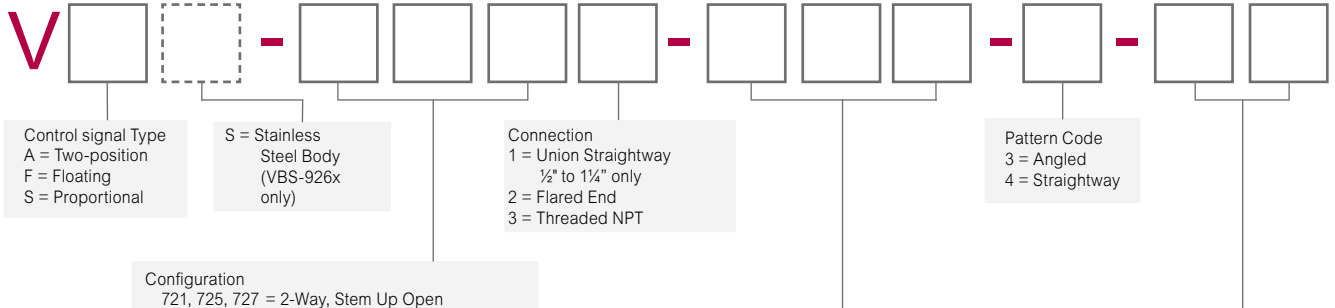

Actuator code Two-position, SR
MA51-7100 = 801
MA51-7101 = N/Ad MA51-7103-100 = 804
MA51-7200 = N/Ad
MA51-7201 = N/Ad
MA51-7203 = 593
MA40-7040 = N/Ad
MA40-7040-501 = N/Ad
MA40-7041 = N/Ad
MA40-7041-501 = N/Ad
MA40-7043 = N/Ad
MA40-7043-501 = N/Ad
MA41-7070 = N/Ad
MA41-7070-502 = N/Ad
MA41-7071 = N/Ad
MA41-7071-502 = N/Ad
MA41-7073 = N/Ad
MA41-7073-502 = N/Ad
MA41-7150 = N/Ad
MA41-7150-502 = N/Ad
MA41-7151 = N/Ad
MA41-7151-502 = N/Ad
MA41-7153 = N/Ad
MA41-7153-502 = N/Ad
MA40-7170 = N/Ad
MA40-7173 = N/Ad

Actuator code PROPORTIONAL, SR
MS51-7103-100 = 804
MS51-7103-130 = N/Ad
MS51-7103-140 = N/Ad
MS51-7103-150 = 812
MS51-7103-160 = 814
MS51-7203 = 593
MS51-7203-040 = N/Ad
MS51-7203-050 = N/Ad
MS40-7043 = 536
MS40-7043-501 = 537
MS40-7043-MP = N/Ad
MS40-7043-MP5 = N/Ad
MS41-7073 = 546
MS41-7073-502 = 547
MS41-7153 = 556
MS41-7153-502 = 557
MS40-7170 = N/Ad
MS40-7173 = 576
Non-Spring Return NSR
MS41-6043 = N/Ad
MS41-6083 = N/Ad
MS41-6083-502 = N/Ad
MS41-6153 = N/Ad
MS41-6153-502 = N/Ad
MG350V-24M = 110
MGF350V-24MP = 112

Actuator code FLOATING, SR
MF51-7103-100 = 804
MF51-7203 = N/Ad
MF40-7043 = N/Ad
MF40-7043-501 = N/Ad
MF41-7073 = N/Ad
MF41-7073-502 = N/Ad
MF41-7153 = N/Ad
MF41-7153-502 = N/Ad
MF40-7173 = N/Ad
Non-Spring Return NSR
MF41-6043 = N/Ad
MF41-6083 = N/Ad
MF41-6083-502 = N/Ad
MF41-6153 = N/Ad
MG350V-24F = 110
MGF350V-24FP = 112

Port Code

Body Size	2-Way		3-Way		Port Code
	Cv	Port Code	Cv		
			Mixing	Diverting	
1/2"	0.4	01	-	-	
	1.3	02		2.2	02
	2.2	03	-	-	
3/4"	4.4	04		4.4	04
	5.5	05	-	-	
1"	7.5	06		7.5	06
	10.0	07	-	-	
1 1/4"	14.0	08	14.0	15.0	08
	20	09	20.0	20.0	09
1 1/2"	28	10	28.0	28.0	10
	40	11	41.0	40.0	11

d - Factory assemblies not available. Purchase actuator and valve body separately and field assemble.

The configuration of the valve assembly determines the valve stem position and flow, as shipped from the factory. See the table below.

Valve Assemblies	Valve Body Action	Factory Shipped Position		Action
		Valve Stem	Flow	
Vx-721x-xxx-4-P Vx-725x-xxx-4-P Vx-727x-xxx-4-P	2-Way Stem Up Open	Up	Open	A to AB Flow decreases as actuator extends
Vx-722x-xxx-4-P Vx-726x-xxx-4-P Vx-728x-xxx-4-P Vxs-9263-xxx-x-P	2-Way Stem Up Closed		Closed	A to AB Flow increases as actuator extends
Vx-731x-xxx-4-P	3-Way		Flow B to AB	A to AB Flow increases as actuator extends B to AB Flow decreases as actuator extends
Vx-732x-xxx-4-P	3-Way Diverting			B to A Flow increases as actuator extends B to AB Flow decreases as actuator extends

Ordering VB-7000 Globe Valve Assemblies (Other Actuators) Hydraulic, Pneumatic & Forta Actuators

Specify Six Part Number Fields to Determine the Valve Actuator Assembly Part Number

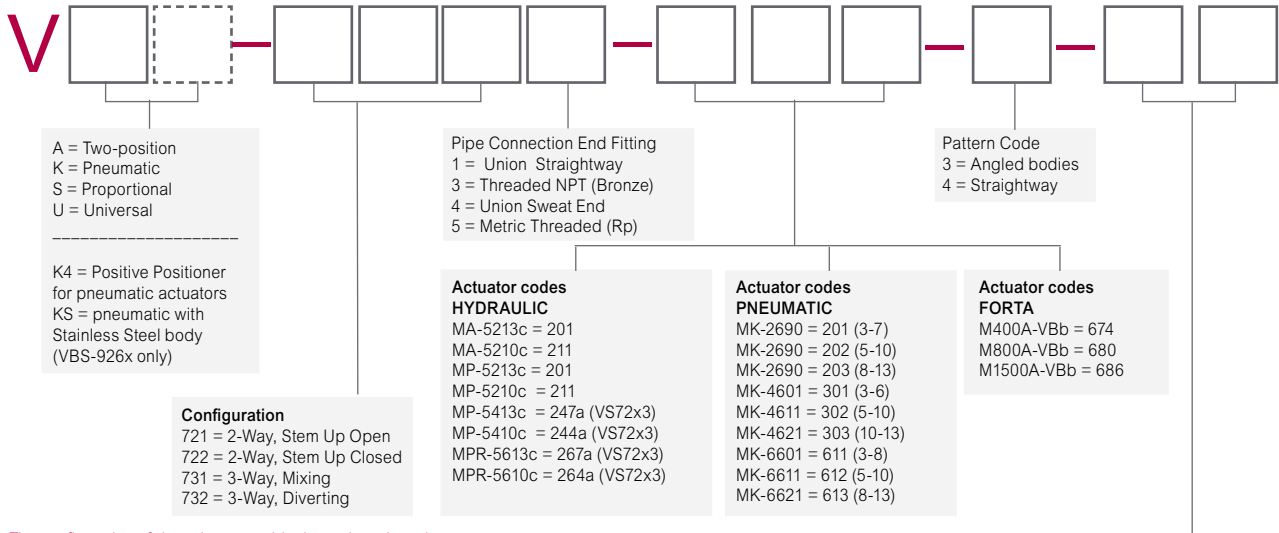

The configuration of the valve assembly determines the valve stem position and flow, as shipped from the factory. See the table below.

Valve Assemblies	Valve Body Action	Factory Shipped Position		Action	
		Valve Stem	Flow		
Vx-721x-xxx-4-P	2-Way Stem Up Open	Up	Open	A to AB Flow decreases as actuator rotates CW	
Vx-722x-xxx-4-P	2-Way Stem Up Closed		Closed	A to AB Flow increases as actuator rotates CW	
Vx-731x-xxx-4-P	3-Way		Flow B to AB		A to AB Flow increases as actuator rotates CW B to AB Flow decreases as actuator rotates CW
Vx-732x-xxx-4-P	3-Way Diverting				B to A Flow increases as actuator rotates CW B to AB Flow decreases as actuator rotates CW

a - AV-601 is not available as an assembly and has to be ordered separately.
b - Add -S2 for auxiliary switch. Only available as a field assembly.
c - Add -500 for auxiliary switch. Only available as a field assembly.

Body Size	Port Code (Up to 2" (Cv of 41))				
	2-Way		3-Way		Port Code
	Cv*	Port Code	Mixing Cv	Diverting Cv	
½"	0.4	01	-	-	
	1.3	02	2.2	2.2	02
	2.2	03	-	-	
¾"	4.4	04	4.4	4.4	04
	5.5	05	-	-	
1"	7.5	06	7.5	7.5	06
	10.0	07	-	-	
1¼"	14.0	08	14.0	15.0	08
	20	09	20.0	20.0	09
1½"	28	10	28.0	28.0	10
2"	40	11	41.0	40.0	11

*Brass trim models listed.

1/2" to 2" 2-Way Globe Valves with Linear SR Actuators

2-Way Linked Globe Valve Assemblies with Linear Series Spring Return Actuators

Choose a valve assembly having a close-off pressure capability sufficient for the application. Not all valve body and actuator combinations are available factory-assembled. Some combinations must be field-assembled.

2-Way Linked Globe Valve Assemblies

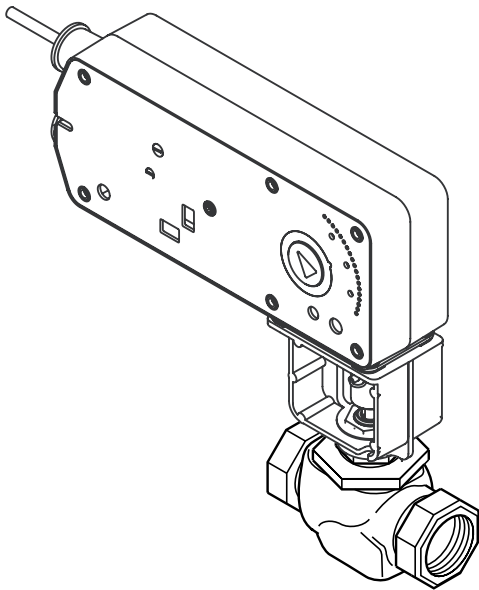

Mx51-710x

Mx51-720x

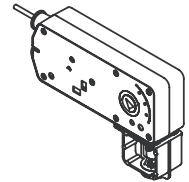
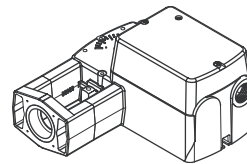

Actuator force rating

105 lbf (467 N)

220 lbf (979 N)

Actuator model (Actuator code)

Two-position
MA51-7100 (801)
MA51-7101
MA51-7103-100 (804)

Floating
MF51-7103-100 (804)

Proportional
MS51-7103-100 (804)
MS51-7103-130
MS51-7103-140
MS51-7103-150 (812)
MS51-7103-160 (814)

Two-position
MA51-7200
MA51-7201
MA51-7203 (593)

Floating
MF51-7203 (593)

Proportional
MS51-7203 (593)
MS51-7203-040
MS51-7203-050

Valve assembly part number bj	P code	Valve size in. (mm)	Cvc	kvsc	Actuator close-off pressure pside		
					N.O.f, j	N.C.g, j	
Vx-72x1-xxx-4-P Vx-72x2-xxx-4-P Vx-72x3-xxx-4-P VxS-9263-0-4-P	1	1/2 (15)	0.4	0.3	250	250	-
	2		1.3	1.1			
	3		2.2	1.9			
	4		4.4	3.8			
	5	3/4 (20)	5.5	4.8	200	200	
	6		7.5	6.5			
	7	1 (25)	10.0	8.7	150	90	
	8		14.0	12			
Vx-72x3-xxx-4-P Vx-72x5-xxx-4-Ph	9	1 1/4 (32)	20.0	17	90	60	150
	10	1 1/2 (40)	28.0	24	60	35	100
	11	2 (50)	40.0	35	32	20	65

b - To determine a specific part number, see "Ordering VB-7000 Globe Valve Assemblies (Other Actuators)" on page 119 for the relevant part series.

c -
$$C_v = \frac{GPM}{\sqrt{\Delta P}}$$
 Where ΔP is measured in psi

$$kvs = \frac{C_v}{1.156}$$

$$kvs = \frac{m^3/h}{\sqrt{\Delta P}}$$
 Where ΔP is measured in bar = 100 kPa

d - Close-off ANSI IV (.01%) for soft seats.

e - Close-off pressure ratings describe only the differential pressure which the actuator can close-off with adequate seating force. Consult valve body specifications for other limitations. The rating value is the pressure difference between the inlet and outlet ports.

f - Normally open (N.O.) assembly using stem up open valve body.

g - Normally closed (N.C.) assembly using stem up closed valve body.

h - Metric thread 15 to 80 mm (Rp 1/2 to Rp 3).

j - Valve body and actuator size determine the close-off capabilities. Example: All 1/2", 2-Way globe valves will make the same close-off regardless of the Cv rating for a given actuator.

1/2" to 2" 2-Way Globe Valves with Linked SR Actuators
2-Way Linked Globe Valve Assemblies with Spring Return Actuators

Choose a valve assembly having a close-off pressure capability sufficient for the application.

**2-Way Spring Return
Linked Globe Valve Assemblies**

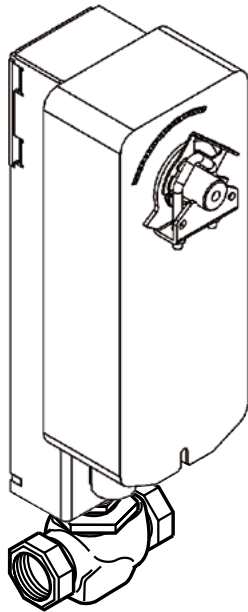

Mx40-704x

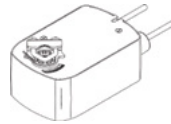

Mx41-7xxx

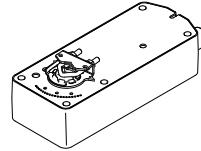

Mx40-717x

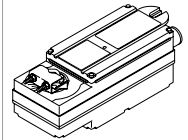

Actuator torque rating (minimum)

35 lb-in (4 N-m)	60 lb-in (7 N-m)	133 lb-in (15 N-m)	150 lb-in (17 N-m)
---------------------	---------------------	-----------------------	-----------------------

Actuator model (Actuator code)

Two-position MA40-7040 MA40-7041 MA40-7043 (536) Floating MF40-7043 (536) Proportional MS40-7043 (536) MS40-7043-501 (537)	Two-position MA41-707x Floating MF41-7073 Proportional MS41-7073 (546) MS41-7073-502 (547)	Two-position MA41-715x Floating MF41-7153 Proportional MS41-7153 (556) MS41-7153-502 (557)	Two-position MA40-717x Floating MF40-7173 Proportional MS40-717x (576)
---	---	---	--

Note: Not all factory Actuator codes are available.

Linkage kit part number

AV-611 (1/2" to 2")	AV-602 (1" to 2")	AV-602 (1/4" to 2")
---------------------	-------------------	---------------------

Valve assembly part number ^a	P code	Valve size in. (mm)	Cv ^b	kvs ^b	Actuator close-off pressure psi ^d			
					Single actuator			
Vx-7214-xxx-4-P Vx-7224-xxx-4-P Vx-7211-xxx-4-P Vx-7213-xxx-4-P Vx-7221-xxx-4-P Vx-7223-xxx-4-P Vx-7253-xxx-4-P Vx-7263-xxx-4-P Vx-7273-xxx-4-P Vx-7283-xxx-4-P VxS-9263-xxx-4-P	01	1/2 (15)	0.4	0.3	250	-	-	-
	02		1.3	1.1				
	03		2.2	1.9				
	04		4.4	3.8				
	05	3/4 (20)	5.5	4.8	125	180	-	-
	06		7.5	6.5				
	07		10.0	8.7				
	08	1 (25)	14.0	12	125	180	180	180
09	1 1/4 (32)	20.0	17	75	120	200	200	
Vx-7213-xxx-4-P Vx-7223-xxx-4-P	10	1 1/2 (40)	28.0	24	50	80	140	160
	11	2 (50)	40.0	35	25	40	80	120

a - To determine a specific part number, see "Ordering VB-7000 Globe Valve Assemblies (Other Actuators)" on page 119 for the relevant part series.

b - kvs = m3/h (ΔP = 100 kPa) kvs = Cv / 1.156 Cv = kvs x 1.156

c - All Vx-72xx leakage ratings are ANSI V to 35psi and ANSI IV above 35psi; with the exception of Vx-7273 and Vx-7283 (ANSI III).

d - For seat leakage ratings, refer to Seat Leakage Classes.

1/2" to 2" 3-Way Globe Valves with Linear SR Actuators

Choose a valve assembly having a close-off pressure capability sufficient for the application. Not all valve body and actuator combinations are available factory-assembled. Some combinations must be field-assembled.

3-Way Linked Globe Valve Assemblies

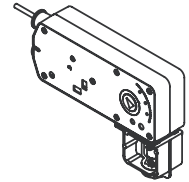
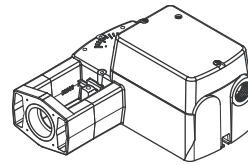
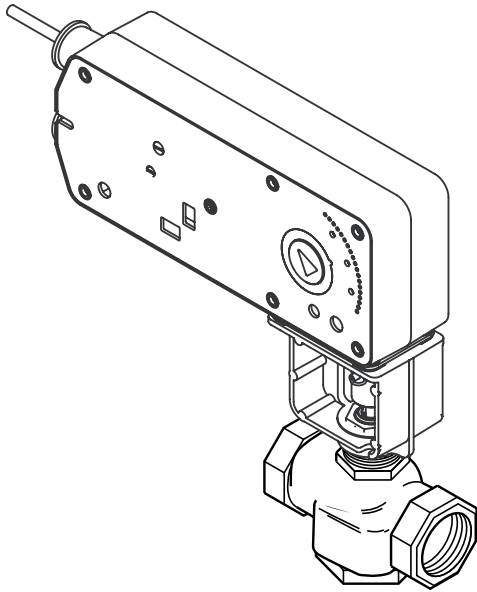

Mx51-710x	Mx51-720x
Actuator force rating	
105 lbf (467 N)	220 lbf (979 N)
Actuator model (Actuator code)^b	
Two-position MA51-7100 MA51-7101 MA51-7103-100 (804)	Two-position MA51-7200 MA51-7201 MA51-7203 (593)
Floating MF51-7103-100 (804)	Floating MF51-7203
Proportional MS51-7103-100 (804) MS51-7103-130 MS51-7103-140 MS51-7103-150 (812) MS51-7103-160 (814)	Proportional MS51-7203 (593) MS51-7203-040 MS51-7203-050

Valve assembly part number ^c	P code	Valve size in. (mm)	Cvd	kvs ^d	Actuator close-off pressure psi ^e		
Mixing Vx-7313-xxx-4-P	2	1/2 (15)	4.4	3.8	250	-	
	4						
	6	3/4 (20)	7.5	6.5	200		
	8	1 (25)	14.0	12.0	90	150	
	9	1 1/4 (32)	20.0	17	60		
	10	1 1/2 (40)	28	24	35		100
	11	2 (50)	41	36	20		65
Diverting Vx-7323-xxx-4-P	4	1/2 (15)	4.4	3.8	250	-	
	6	3/4 (20)	7.5	6.5			
	8	1 (25)	15.0	13.0			
	9	1 1/4 (32)	20.0	17.3		250	
	10	1 1/2 (40)	28	24.2			
	11	2 (50)	40	34.6			

b - Models without actuator codes are not offered as factory assemblies. Purchase the actuator and the valve body separately and field assemble. For available factory assemblies, consult the price schedule.

c - To determine a specific part number, see "Ordering VB-7000 Globe Valve Assemblies (Other Actuators)" on page 119 for the relevant part series.

d - $C_v = \text{gpm} / \sqrt{\Delta P}$ (where ΔP is measured in psi.) $kvs = C_v / 1.156$

e - Close-off pressure ratings describe only the differential pressure which the actuator can close-off with adequate seating force. Consult valve body specifications for other limitations. The rating value is the pressure difference between the inlet and outlet ports.

1/2" to 2" 3-Way Globe Valves with Linked SR Actuators 3-Way Linked Globe Valve Assemblies with Spring Return Actuators

Choose a valve assembly having a close-off pressure capability sufficient for the application. Not all valve body and actuator combinations are available factory-assembled. Some combinations must be field-assembled.

3-Way Spring Return
Linked Globe Valve Assemblies

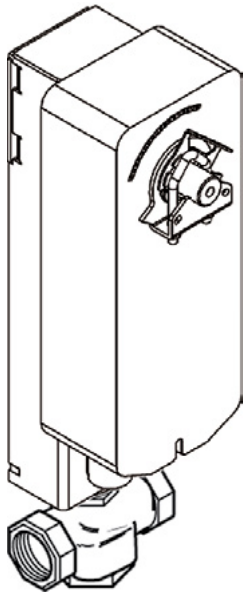

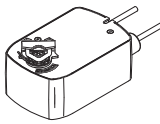
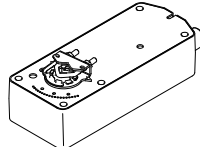
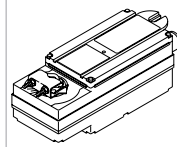
Mx40-704x	Mx41-7xxx	Mx40-7173	
			
Actuator torque rating (minimum)			
35 lb-in (4 N-m)	60 lb-in (7 N-m)	133 lb-in (15 N-m)	150 lb-in (17 N-m)
Actuator model (Actuator code)			
Two-position MA40-7040 MA40-7041 MA40-7043 (536) Floating MF40-7043 (536) Proportional MS40-7043 (536) MS40-7043-502 (537)	Two-position MA41-707x Floating MF41-7073 Proportional MS41-7073 (546) MS41-7073-502 (547)	Two-position MA41-715x Floating MF41-7153 Proportional MS41-7153 (556) MS41-7153-502 (557)	Two-position - Floating MF40-7173 Proportional MS40-7173 (576)
Note: Not all factory Actuator codes are available.°			
Linkage kit part number			
AV-611 (1/2" to 2")	AV-602 (1" to 2")	AV-602 (1/2" to 2")	AV-602

Valve assembly part number ^b	P code	Valve size in. (mm)	Cv ^c	kvs ^c	Actuator close-off pressure psig ^d			
					Single actuator			
Vx-7313-xxx-4-P	02	1/2 (15)	2.2	1.9	250	-	-	250
	04		4.4	3.8				
	06	3/4 (20)	7.5	6.5				
	08	1 (25)	14.0	12.0	125	180	-	250
	09	1 1/4 (32)	20.0	17	75	100	-	-
	10	1 1/2 (40)	28	24	50	70	140	160
	11	2 (50)	41	36	25	40	80	120
Vx-7323-xxx-4-P	02	1/2 (15)	2.2	1.9	250	-	-	-
	04		4.4	3.8				
	06	3/4 (20)	7.5	6.5				
	08	1 (25)	15	13.0				
	09	1 1/4 (32)	20	17.3				
	10	1 1/2 (40)	28	24.2				
	11	2 (50)	40	34.6				

b - To determine a specific part number, see "Ordering VB-7000 Globe Valve Assemblies (Other Actuators)" on page 119 for the relevant part series.

c - kvs = m³/h (ΔP = 100 kPa) kvs = Cv / 1.156 Cv = kvs x 1.156

d - Mixing Valves A port seat leakage ANSI IV, B port seat leakage ANSI III, Diverting Valves seat leakage is ANSI III.

e - For field assembly, factory actuator, linkage and valve assembly may be offered.

1/2" to 2" 2-Way Globe Valves with Linked NSR Actuators 2-Way Linked Globe Valve Assemblies with Non-Spring Return Actuators

Choose a valve assembly having a close-off pressure capability sufficient for the application. Not all valve body and actuator combinations are available factory-assembled. Some combinations must be field-assembled.

2-Way Non-Spring Return Linked Globe Valve Assemblies^f

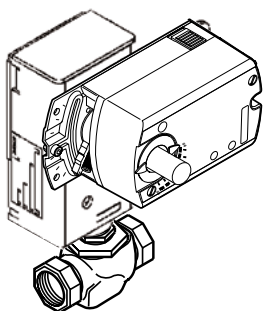

Note: Only bronze bodies listed. VBS-9263-0-4-P stainless steel bodies to -06 are available with the same close-off performance.

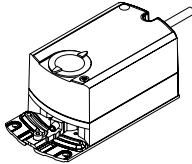
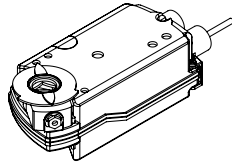
					Mx41-60x3	Mx41-6153			
									
					Actuator Torque Rating (minimum)				
					44 lb-in. (5 N-m)	88 lb-in. (10 N-m)	133 lb-in. (15 N-m)		
					Actuator Model (Actuator Code)				
					Floating MF41-6043 Proportional MS41-6043	Floating MF41-6083 Proportional MS41-6083	Floating MF41-6153 Proportional MS41-6153		
					Note: Not all factory actuator codes are available. ^f				
					Linkage Kit Part Number				
					AV-611				
					Actuator Close-off Pressure psi ^{cd}				
Valve Assembly Part Number ^a	P Code	Valve Size in. (mm)	Cv ^b	kvs ^b	Single Actuator				
Vx-7211-xxx-4-P Vx-7213-xxx-4-P Vx-7214-xxx-4-P Vx-7221-xxx-4-P Vx-7223-xxx-4-P Vx-7224-xxx-4-P Vx-7253-xxx-4-P Vx-7263-xxx-4-P Vx-7273-xxx-4-P Vx-7283-xxx-4-P	01	1/2 (15)	0.4	0.3	225	-			
	02		1.3	1.1					
	03		2.2	1.9					
	04		4.4	3.8					
	05	3/4 (20)	5.5	4.8					
	06		7.5	6.5					
	07	1 (25)	10.0	8.7				100	130
	08		14.0	12					
	09	1 1/4 (32)	20.0	17				60	100
Vx-7213-xxx-4-P Vx-7223-xxx-4-P	10	1 1/2 (40)	28.0	24	40	70	140		
	11	2 (50)	40.0	35	20	40	80		

a - To determine a specific part number, see "Ordering VB-7000 Globe Valve Assemblies (Other Actuators)" on page 119 for the relevant part series.

b - kvs = m³/h (ΔP = 100 kPa) kvs = Cv / 1.156 Cv = kvs x 1.156

c - All Vx-72xx leakage ratings are ANSI V to 35 psi and ANSI IV above 35 psi; with the exception of Vx-7273 and Vx-7283 (ANSI III).

d - Close-off pressure ratings describe only the differential pressure which the actuator can close-off with adequate seating force. Consult valve body specifications for other limitations. The rating value is the pressure difference between the inlet and outlet ports.

f - Shown for field assembly.

1/2" to 2" 3-Way Globe Valves with Linked NSR Actuators 3-Way Linked Globe Valve Assemblies with Non-Spring Return Actuators

Choose a valve assembly having a close-off pressure capability sufficient for the application. Not all valve body and actuator combinations are available factory-assembled. Some combinations must be field-assembled.

3-Way Non-Spring Return
Linked Globe Valve Assemblies^f

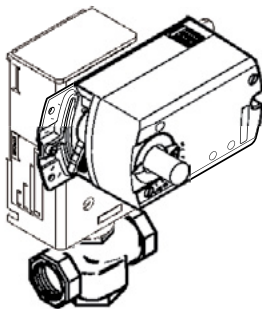

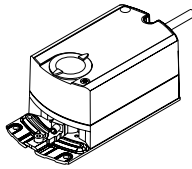
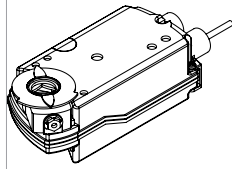
					Mx41-60x3	Mx41- 6153	
							
					Actuator Torque Rating (minimum)		
					44 lb-in (5 N-m)	88 lb-in (10 N-m)	133 lb-in (15 N-m)
					Actuator Model (Actuator Code)		
					Floating MF41-6043	Floating MF41-6083	Floating MF41- 6153
					Proportional MS41-6043	Proportional MS41-6083	Proportional MS41- 6153
					Note: Not all factory actuator codes are available.		
					Linkage Kit Part Number		
					AV-611		
Valve Assembly Part Number ^a	P Code	Valve Size in. (mm)	Cv ^b	kvs ^b	Actuator Close-off Pressure psi ^{c,e}		
Vx-7313-xxx-4-P	02	1/2 (15)	2.2	1.9	225	-	-
	04		4.4	3.8			
	06	3/4 (20)	7.5	6.5			
	08	1 (25)	14.0	12.0	100	180	
	09	1 1/4 (32)	20.0	17	60	120	
	10	1 1/2 (40)	28	24	40	75	140
	11	2 (50)	41	36	20	40	80
Vx-7323-xxx-4-P	02	1/2 (15)	2.2	1.9	250	-	-
	04		4.4	3.8			
	06	3/4 (20)	7.5	6.5			
	08	1 (25)	15.0	13.0			
	09	1 1/4 (32)	20.0	17.3			
	10	1 1/2 (40)	28	24.2			
	11	2 (50)	40	34.6			

a - To determine a specific part number, see "Ordering VB-7000 Globe Valve Assemblies (Other Actuators)" on page 119 for the relevant part series.

b - $kvs = m^3/h (\Delta P = 100 \text{ kPa})$ $kvs = Cv / 1.156$ $Cv = kvs \times 1.156$

c - Mixing Valves A port seat leakage ANSI IV, B port seat leakage ANSI III, Diverting Valves seat leakage is ANSI III.

e - Dual actuators are not available as factory assemblies.

Some factory assembly may be available but components may be ordered separately for field assembly.

f - Shown for field assembly.

More info

Scan the QR code or visit the link below for more information.



Visit:
<http://goo.gl/BnGiYc>

1/2" to 2" 2 - and 3-Way Globe Valves with MG350V NSR Actuators

Applicable literature

- MG350V Economy Model - Standard Speed, MG350V-24F, MG350V-24M
- F-27907 Specification Sheet
- F-27852 Installation instructions
- MG350V Economy Plus Model - Fast Speed + Feedback/Alarms MGF350V-24FP, MGF350V-24MP

MG350V installed on a VB-7000 Globe Valve

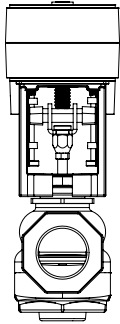

End View

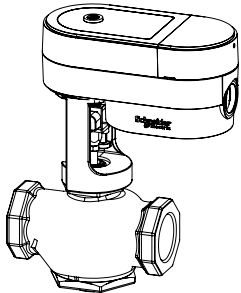

Side View

Select valve actuator combination having sufficient close-off for application.

Compatible Two-Way Valve Series

Body		Close-off Ratings, psi (kPa) ^a		Valve Bodies
P code	Size	MGF350V-24FP, MGF350V-24MP	MG350V-24F, MG350V-24M	
-01, -02, -03, -04	1/2" (15 mm)	219 (1510)	250 (1724)	VB-7211-0-3-P, VB-7211-0-4-P, VB-7212-0-4-P, VB-7213-0-4-P,
-05, -06	3/4" (20 mm)	135 (931)	157 (1082)	VB-7214-0-4-P, VB-7221-0-4-P,
-07, -08	1" (25 mm)	67 (462)	79 (545)	VB-7222-0-4-P, VB-7223-0-4-P,
-09	1 1/4" (32 mm)	42 (290)	49 (338)	VB-7224-0-4-P, VB-7253-0-4-P, VB-7263-0-4-Pa, VB-7273-0-4-P, VB-7283-0-4-P

Compatible Three-Way Valve Series

-02, -04	1/2" (15 mm)	219 (1510)	250 (1724)	
-06	3/4" (20 mm)	135 (931)	157 (1082)	VB-7312-0-4-P, VB-7313-0-4-P,
-08	1" (25 mm)	67 (462)	79 (545)	VB-7314-0-4-P, VB-7363-0-4-P,
-09	1 1/4" (32 mm)	42 (290)	49 (338)	
-04, -06, -08, -09, -10, -11	1/2" to 2"	250 (1712)		VB-7323-0-4-P

a - VB-7263 series valves with port codes from -28 to -82 have the same close-off ratings as the respective matching pipe size VB-7263 series valves with port codes -01 to -11.

Actuator diagram

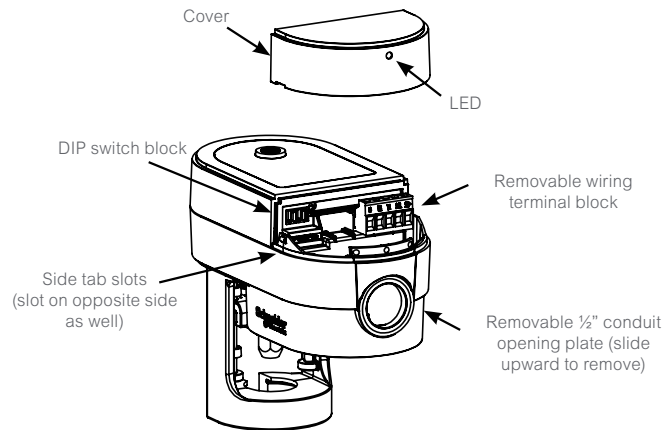

1/2" to 2" 2/3-Way Globe Valves with NSR Actuators



Select a valve actuator combination having sufficient close off for the application.

Valve Body ^a			Close-off Ratings, psi (kPa)				
2-Way Valves ^{bc}	P code	Size	M400A (VB) 674	M800A (VB) 680	M1500A (VB) 686		
VB-7211-0-3-P VB-7211-0-4-P VB-7212-0-4-P VB-7213-0-4-P VB-7214-0-4-P VB-7221-0-4-P VB-7222-0-4-P VB-7223-0-4-P VB-7224-0-4-P VB-7253-0-4-P VB-7263-0-4-P VB-7273-0-4-P VB-7283-0-4-P	-01, -02, -03, -04	1/2" (15 mm)	250 (1712)	250 (1712)	-		
	-05, -06	3/4" (20 mm)	198 (1356)	250 (1712)			
	-07, -08	1" (25 mm)	92 (630)	207 (1418)			
	-09	1 1/4" (32 mm)	56 (384)	130 (890)			
	-10	1 1/2" (40 mm)	37 (253)	88 (603)		177 (1212)	
	-11	2" (40 mm)	19 (130)	48 (329)		98 (671)	
	3-Way Valves^b			M400A (VB)		M800A (VB)	M1500A
	VB-7312-0-4-P VB-7313-0-4-P VB-7314-0-4-P	-02, -04	1/2" (15 mm)	250 (1712)		250 (1712)	-
-06		3/4" (20 mm)	198 (1356)	250 (1712)			
-08		1" (25 mm)	92 (630)	207 (1418)			
-09		1 1/4" (32 mm)	56 (384)	130 (890)			
-10		1 1/2" (40 mm)	37 (253)	88 (603)			
-11		2" (40 mm)	19 (130)	48 (329)			
VB-7323-0-4-P	-04, -06, -08, -09, -10, -11	1/2" to 2"	250 (1712)		Do not use		

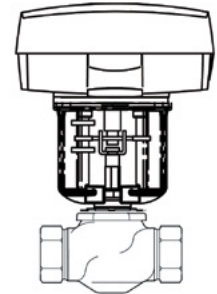

Mx00A-VB Valve Actuator Mounted on a 2-Way VB-7000 Series Valve

a - Not all bodies are available for all port codes.
 b - Substitute VU- for VB- and add the Actuator code to substitute for the -0- (e.g., 674, 680, etc.).
 c - Not all valve styles are available in all sizes or "P" codes.

1/2" to 2" Globe Valves with Hydraulic SR Actuators

Select Actuator Type or Actuator Code (xxx) series with correct input signal for sufficient close-off for the application. Not all valve body and actuator combinations are available factory-assembled. Some combinations must be field-assembled.

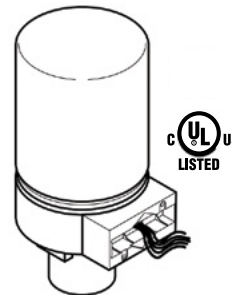

More information: Scan the QR code or visit the link below for more information.



Visit: <http://goo.gl/EpcPNP>

Actuator Valves for the Hydraulic Spring Return Actuators

Actuator				MA-521x	MP-5xxx	MPR-561x
Input signal				2-Position Electric	VDC	mA ^{dc}
Actuator code (xxx)				a	a	
	Factory available valve assembly	Valve body	P code	Size	Close-off pressure rating (psi)	
N.O.	VA-7213-2xx-4-P VS-7213-xxx-4-P	VB-7213-0-4-P VB-7214-0-4-P VB-7253-0-4-P VB-7273-0-4-P	-01, -02, -03, -04	1/2" (15 mm)	130	
			-05, -06	3/4" (20 mm)	80	
			-07, -08	1" (25 mm)	40	
			-09	1 1/4" (32 mm)	25	
			-10	1 1/2" (40 mm)	15	
			-11	2" (40 mm)	10	
N.C.	VA-7223-2xx-4-P VS-7223-xxx-4-P	VB-7223-0-4-P VB-7224-0-4-P VB-7263-0-4-P VB-7283-0-4-P	-01, -02, -03, -04	1/2" (15 mm)	200	130
			-05, -06	3/4" (20 mm)	130	80
			-07, -08	1" (25 mm)	50	40
			-09	1 1/4" (32 mm)	35	25
			-10	1 1/2" (40 mm)	35	25
			-11	2" (40 mm)	20	14

a - Hydraulic actuators require AV-7600-1 linkage if field assembled. MP-541x and MPR-561x require AV-601 linkage extension for field assembly.

3-Way Hydraulic Valve Actuator Close-Off Ratings

Linkage (1/2 to 2")				AV-7600-1 ^a	AV-7600-1		
Input signal				Electronic VDC & 4 to 20 mA	SPDT Floating & 2-Position		
Actuator code (XXX)				2XX	2XX		
Actuator type				MP-5X1X-XXX ^b MPR-561X	MA-521X		
Factory available valve assembly	Valve body	P code	Size (in.)	Actuator close-off pressure ratings (psi) ^{c,d,e}			
				SU ^f "A"	SD ^f "B"	SU ^f "A"	SD ^f "B"
VA-7313-XXX-4-P VS-7313-XXX-4-P	VB-7313-0-4-P VB-7314-0-4-P	-02,-04	1/2	130	200	130	
		-06	3/4	80	130	80	
		-08	1	40	50	40	
		-09	1 1/4	25	35	25	
		-10	1 1/2	15	35	25	
		-11	2	10	20	14	
VA-7323-XXX-4-P VS-7323-XXX-4-P	VB-7323-0-4-P	-04	1/2	250			
		-06	3/4				
		-08	1				
		-09	1 1/4				
		-10	1 1/2				
		-11	2				
VF-7313-XXX-4-P	VB-7312-0-4-P VB-7313-0-4-P VB-7314-0-4-P	-02,-04	1/2 or 5/8		200	130	
		-06	3/4		130	80	
		-08	1		50	40	
		-09	1 1/4		35	25	
		-10	1 1/2		20	15	
		-11	2		14	10	

a - MP-541X, MPR-5XXX use AV-7600-1 or AV-600 and AV-601.

b - Factory shipments have unpainted large springs. For 0 to 10 volt and 4 to 20 mA controllers, use blue and booster springs.

c - Close-off ratings for mixing or sequencing valves: (SU = "A" port, SD = "B" port). "A" port (SU) ratings equal pressure at port "A" minus pressure at port "B"; "B" port (SD) ratings equal pressure at port "B" minus pressure at port "A".

d - Close-off pressure ratings describe only the differential pressure which the actuator can close-off to standards with adequate seating force. Consult valve body specifications for other limitations.

e - Diverting valves may be used in mixing applications with minor affects on flow.

f - SU- Stem Up; SD- Stem Down.

1/2" to 2" 2-Way and 5/8" 3-Way Globe Valves with Pneumatic Actuators

Select Actuator Type or Actuator Code (xxx) series with correct input signal for sufficient close-off for the application. If selecting component parts, select Valve Body and Positive Positioner if required.

2-Way 1/2" to 2" Globe Valves with Pneumatic Actuators

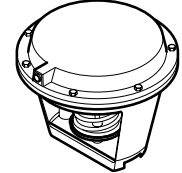
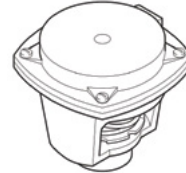
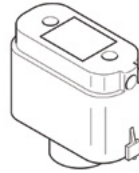

Effective area		6 Sq. in.			11 Sq. in.			50 Sq. in.				
Actuator		MK-2690			MK-4601	MK-4611	MK-4621	MK-6601	MK-6611	MK-6621		
Factory Actuator code (xxx)*		201	202	203	301	302	303	611	612	613		
Spring range (psig)		3 to 7	5 to 10	8 to 13	3 to 6	5 to 10	10 to 13	3 to 8	5 to 10	8 to 13		
Linkage		AV-7400			AV-401			AV-430				
Positive Positioner (VK4)		AK-42309-500			AK-42309-500			AK-42309-500				
Factory available assembly with Positive Positioner		N.O. valves		Yes	No		Yes	No		Yes	No	
		N.C. valves		No		Yes	No		Yes	No		Yes

Actuator close-off pressure rating (psi)

NP	Factory available valve assembly	Valve body	P code	Size in.	Supply air pressure (psig)																
					15	20	15	20	15	20	15	20	15	20	15	20	15	20	15	20	
2-Way N.O.	VK-7213-xxx-4-P VK4-7213-xxx-4-P VK-7214-xxx-4-P VK4-7214-xxx-4-P	VB-7213-0-4-P VB-7214-0-4-P VB-7253-0-4-P VB-7373-0-4-P	-1-2-3-4	1/2	130	220	60	170	90	250	250	120	250	10	200						
			-5-6	3/4	80	130	40	120	60	180	250	80	180	120							
			-7-8	1	25	70	15	50	25	90	150	35	100	65							
			-9	1 1/4	20	40	8	30	15	50	90	20	60	40							
			-10	1 1/2	14	29	5	20	9	30	60	10	40	25	170	250	110	230	40	160	
			-11	2	6	14	-	10	-	15	30	-	20	-	90	160	60	120	20	90	
2-Way N.C.	VK-7223-xxx-4-P VK4-7223-xxx-4-P VK-7224-xxx-4-P VK4-7224-xxx-4-P	VB-7223-0-4-P VB-7224-0-4-P VB-7263-0-4-P VB-7283-0-4-P	-1-2-3-4	1/2	50		130	30	100	250											
			-5-6	3/4	30		60	20	70	160											
			-7-8	1	9		30	5	30	60											
			-9	1 1/4	-		15	-	15	40											
			-10	1 1/2	-		10	-	10	35	40	80	170								
			-11	2	-		-	-	-	15	20	50	90								

*Not all Actuator codes are factory assembled. If the assembly is no longer available but a close-off is shown on the tables above you may order the components that make up the assembly for field assembly. Note: Only bronze bodies listed. VBS-9263-0-4-P stainless steel bodies to -06 size are available with the same close off performance.

3-Way 5/8" Globe Valves with Pneumatic Actuators

Positive Positioner		AK-42309-500			AK-42309-500			
Actuator		MK-2690			MK-4601	MK-4611	MK-4621	MK-4621-422
Factory Actuator code (xxx)		201	202	203	301	302	303	313
Spring range (psig)		3 to 7	5 to 10	8 to 13	3 to 6	5 to 10	10 to 13	10 to 11.25
Linkage		AV-7400			AV-401			AV-430

Actuator close-off pressure rating (psi)^{bb}

Supply air pressure (psig)					15/20	15	20	15/20	15	20	15/20	15	20	15/20	15	20	15/20	15	20	15/20	15	20			
Stem position					SU	SD	SD	SU	SD	SD	SU	SU	SD	SU	SD	SD	SU	SD	SD	SU	SD	SD			
NPd	Valve assembly	Valve body	P code	Size																					
SUc	VK-7312-xxx-4-P	VB-7312-0-4-P	-2-4	5/8"	5	100	75	60	50	135	95	5	85	35	250	250	130	220	240	250	30	170	-	-	-
	VK-7332-xxx-4-P	VB-7332-0-4-P	-2-3-4		-	-	-	-	-	-	-	35	-	35	-	-	-	35	-	35	35	-	35	-	35

a - Close-off ratings for mixing valves: (SU = "A" port, SD = "B" port). The "A" port (SU) ratings equal pressure at Port "A" minus pressure at port "B". The "B" port (SD) ratings equal pressure at port "B" minus pressure at port "A". Close-off ratings in the table are true only when the indicated supply air pressure is applied to the actuator. A change in air pressure at the actuator alters the actual close-off pressure.

b - Close-off pressure ratings describe only the differential pressure which the actuator can close off to standards with adequate seating force. Consult valve body specifications.

c - SU - Stem Up (Flow "B" to "AB"); SD - Stem Down (Flow "A" to "AB"); Normal Position Stem Up (Flow "B" to "AB").

d - NP = Normal Position.

1/2" to 2" 3-Way & Diverting/Sequencing with Pneumatic Actuators

3-Way & Diverting/Sequencing 1/2" to 2" Globe Valves with Pneumatic Actuators

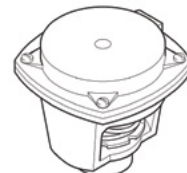
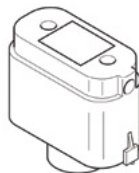

Effective area	6 sq. In.			11 sq. In.		
Linkage	AV-7400			AV-401		
Positive Positioner	AK-42309-500			AK-42309-500		
Factory assembly with Positive Positioner	No	Yes	Yes	No	Yes	Yes
Actuator code (XXX)	201	202	203	301	302	303
Actuator	MK-2690			MK-4601	MK-4611	MK-4621
Spring range (psig)	3 to 7	5 to 10	8 to 13	3 to 6	5 to 10	10 to 13

Actuator close-off pressure rating^{abc}

Supply air pressure (psig)				15/20	15	20	15/20	15	20	15/20	15	20	15/20	15	20	15/20	15	20	15/20	15	20			
Stem position ^d				SU	SD	SD	SU	SD	SD	SU	SD	SD	SU	SD	SD	SU	SD	SD	SU	SD	SD			
Valve assembly	Valve body	P code	Size in.	-																				
				-2-4	1/2	150	150	50	60	170	100	90	30	250	250	100	150	250	250	35	200			
				-6	3/4	60	120	30	40	100	60	60	20	180	230	70	80	180	160	15	120			
				-8	1	30	60	9	15	50	30	25	5	90	150	30	40	100	60	5	65			
				-9	1 1/4			8	30	15	15			50	90	15	25	60	40			40		
				-10	1 1/2					20	10	9			30	60	10	15	40	35			25	
-11	2					10	-	-			15	30	-	5	20	15			10					
VK-7313-XXX-4-P VK4-7313-XXX-4-P VK-7314-XXX-4-P VK4-7314-XXX-4-P	VB-7313-0-4-P VB-7314-0-4-P			-																				
				-4	1/2	-																		
				-6	3/4	-																		
				-8	1	-																		
				-9	1 1/4	-																		
				-10	1 1/2	-																		
VK-7323-XXX-4-P VK4-7323-XXX-4-P	VB-7323-0-4-P			250																				
				-4	1/2	-																		
				-6	3/4	-																		
				-8	1	-																		
-9	1 1/4	-																						
-10	1 1/2	-																						
-11	2	-																						

a - Close-off ratings for mixing or sequencing valves: (SU = "A", SD = "B" port). "A" port (SU) ratings equal pressure at port "A" minus pressure at port "B". "B" port (SD) ratings equal pressure at port "B" minus pressure at port "A". Close-off ratings in the table are true only when the indicated supply air pressure is applied to the actuator. A change in air pressure at the actuator alters the actual close-off pressure.

b - Close-off pressure ratings describe only the differential pressure which the actuator can close-off with adequate seating force. Consult valve body specifications for other limitations.

c - Mixing valves can be used in a diverting application but diverting valves can not be used in mixing applications.

d - SU - Stem Up; SD - Stem Down. Refer to the valve size and selection chart on page 95 for flow pattern, port designations and normal position.

More info

Scan the QR code or visit the link below for more information.



Visit:
<http://goo.gl/3ftGOA>

1½” to 2” 3-Way & Diverting/Sequencing with Pneumatic Actuator

3-Way & Diverting/Sequencing 1½” & 2” Globe Valves with Pneumatic Actuators

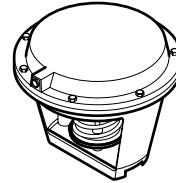

Effective area (stroke)	50 Sq. In. (½")											
Linkage VB-7313-0-4-P	AV-430											
Linkage VB-7323-0-X-P	AV-430											
Positive positioner	AK-42309-500											
Factory assembly with positive positioner	No	Yes			Yes							
Actuator code (XXX)	611	612			613							
Actuator	MK-6601	MK-6611			MK-6621							
Spring range (psig)	3 to 8	5 to 10			8 to 13							
Actuator close-off pressure rating (psi) ^{abc}												
Supply air pressure (psig)	15/20	15	20	15/20	15	20	15/20	15	20			
Stem position ^d	SU	SD	SD	SU	SD	SD	SU	SD	SD			
Valve assembly	Valve body	P code	Size in.	-								
VK-7313-XXX-4-P VK4-7313-XXX-4-P	VB-7313-0-4-P VB-7314-0-4-P	-10	1½	40	170	250	80	110	230	170	30	160
		-11	2	20	90	160	50	60	120	90	15	90
VK-7323-XXX-4-P VK4-7323-XXX-4-P	VB-7323-0-4-P	-10	1½	250								
		-11	2									

a - Close-off ratings for mixing or sequencing valves: (SU = "A", SD = "B" port). "A" port (SU) ratings equal pressure at port "A" minus pressure at port "B". "B" port (SD) ratings equal pressure at port "B" minus pressure at port "A". Close-off ratings in the table are true only when the indicated supply air pressure is applied to the actuator. A change in air pressure at the actuator alters the actual close-off pressure.

b - Close-off pressure ratings describe only the differential pressure which the actuator can close-off to standards with adequate seating force. Consult valve body specifications for other limitations.

c - Mixing valves can be used in a diverting application but diverting valves can not be used in mixing applications.

d - SU- Stem Up; SD- Stem Down. Refer to the valve size and selection chart on page 95 for flow pattern, port designations and normal position.

MG350V Globe Valve NSR SpaceLogic Actuators

MG350V

MG350V globe valve actuators are non-spring return electro-mechanical actuators for the control of two-way and three-way globe valves for fan coils, unit ventilators, reheat, cooling units, perimeter heating, and other applications.

Proportional, Floating, and Pulse Width Modulated (PWM) models are available for direct mounting on ½" to 2" VB-7000 globe valves. The MG350V actuators are also compatible with older field installed ½" to 1¼" VB-9000 globe valves as well as other valves (with the addition of AV-800 Globe Valve Adapters).



MG350V



Benefits

- Tri-color LED status indication for motion indication, auto calibration, and alarm notification
- Auto calibration provides precise control by scaling the Input signal to match the exact travel of the valve stem.
- Proportional models with and without a position output signal with field selectable 2 to 10 VDC and 0 to 10 VDC Input signals and selectable Input signal action (reverse or direct acting)
- Floating and Two-position models available with and without a position output signal
- Pulse width modulated (PWM) models with field-selectable 0.59 to 2.93 sec and 0.1 to 25.5 sec input signal ranges with a position output signal
- Stall protected throughout stroke
- Manual override with automatic release.
- Position feedback output signal models include field selectable 2...10 Vdc or 0...5 Vdc output signal.
- Removable wiring screw terminal with ½" conduit opening
- Integral linkage and self-adjusting valve position indicator

*The CE mark indicates RoHS2 compliance. Please refer to the CE Declaration of Conformity for additional details.

MG350V specifications

Input power and ratings

Part number	Input signal	Position feedback output signal	Approx. Timing in seconds for ½" (12.7 mm) stroke	Max. stroke in. (mm)	Force lbf (N)
MG350V-24F	Three-Wire Floating ¹	-	102	21/32 (16.5)	78 (350)
MGF350V-24FP	Three-Wire Floating, PWM 1, 2	2 to 10 VDC, 0 to 5 VDC3	51		67 (300)
MG350V-24M	2 to 10 VDC, 0 to 10 VDC,	-	102		78 (350)
MGF350V-24MP	4 to 20 mA 4	2 to 10 VDC, 0 to 5 VDC3	51		67 (300)

1 Also compatible with Two-position Form A 24 Vac/VDC Input signals.

2 Field-selectable 0.59 to 2.93 sec and 0.1 to 25.5 sec PWM ranges.

3 Field selectable. The 2 to 10 VDC output signal range also includes an alarm signal (see the MGF350V-24FP, MG350V-24M, and MGF350V-24MP Alarm Operation table).

4 Field Selectable.

MG350V Actuator Models

Model	Valve assembly prefix	Actuator code	Force, lbf (N)	Approx. Timing in seconds for ½" stroke	Power ^a	Proportional input ^b (VDC)	Proportional input ^c (VDC, mA)	Floating, two wire (Form A) two position	PWM ^d	Position output signale
MG350V-24F	VF	110	79 (350)	102	5 VA	-	-	Yes	-	-
MGF350V-24FP		112	67 (300)	51	-	-	-	Yes	2 to 10 / 0 to 5 VDC	
MG350V-24M	VS	110	79 (350)	102	7.2 VA	Yes	-	-	-	-
MGF350V-24MP		112	67 (300)	51	-	-	Yes	-	-	2 to 10 / 0 to 5 VDC

a - 24 Vac (Class 2 power supply), ±20%, 50/60 Hz, 20 to 29 VDC, 5 W; see the MG350V series installation instruction (F-27852) for more information.

b - DIP switch configurable 0 to 10 VDC or 2 to 10 VDC control input, (4 to 20 mA requires an externally mounted 500 ohm resistor).

c - DIP switch configurable 0 to 10 VDC, 2 to 10 VDC, or 4 to 20 mA control input.

d - DIP switch configurable 0.1 to 25.5 sec, 0.59 to 2.93 sec.

e - DIP switch configurable 2 to 10 VDC or 0 to 5 VDC.

SpaceLogic M400 M800 and M1500 NSR Actuators

M400A (VB) / M800A (VB) / M1500A (VB)

M400A (VB)/M800A (VB)/M1500A (VB) Series Non-Spring Return linear actuators are available in U-Bolt (Mx00A) and Screw Mount (Mx00A-VB) style for Schneider Electric globe valves with AV-821 linkage kits for mounting to VB-7000 valves. The Screw Mount style screws directly to the bonnet nut on VB-7000 valves (no adapter required). Applications include Chilled or hot water and steam.

Benefits

- Field-selectable input signals include reverse and direct-acting, floating or proportional plus proportional sequencing input signal ranges.
- Floating configuration controlled by a SPDT floating controller
- Proportional configuration - 0 to 10, 2 to 10 VDC or 4 to 20 mA with the addition of a 500 ohm resistor (included)
- Direct/reverse action switch selectable
- Linear force: 90 lbf (400N), 180 lbf (800N), 337 lbf (1500N)
- Die-cast housing with plenum-rated plastic cover for NEMA 2 (IP54 vertical mount only) applications
- Manual override to allow positioning of valve
- Electronic valve sequencing and electronic flow curve (equal percentage or linear) selection
- Torque Overload protection throughout stroke
- Easy "One Touch" input signal/stroke calibration



U-Bolt Style



Screw Mount Style

Applicable literature

- Series Installation Instructions, F-27599
- VB-7000 Selection Guide, F-27490
- VB-8xxx/9xxx Selection Guide, F-27491
- AV-800 Series Linkage Adapters for Competitors Valves, F-27470
- AV-821 Linkage VB-7000, F-27701 (U-Bolt Style Only). AV-821 is required for the Mx00A but is not for the Mx00A-VB.
- AV-822 Linkage VB-8xxx, VB-9xxx, F-27702 (U-Bolt Style Only)
- CA-28 Control Valve Sizing, F-13755

Specifications						
U-Bolt Style	M400A	M400A-S2	M800A	M800A-S2	M1500A	M1500A-S2
Screw Mount Style	M400A-VB	M400A-S2-VB	M800A-VB	M800A-S2-VB	M1500A-VB	M1500A-S2-VB
AC power	24 Vac +/- 10% 50-60 Hz					
DC power	20 to 29 VDC 20 W			20 to 29 VDC 30 W		
Running VA	6		15		24	
Transformer size VA	30		50		50	
Floating control	Yes					
Proportional control	0 to 10 VDC, 2 to 10 VDC or 4 to 20mA with 500 ohm resistor					
Feedback	2 to 10 VDC					
Force	90 lbf (400 N)		180 lbf (800 N)		337 lbf (1500 N)	
2-SPDT aux switch	No	24 Vac 4A res	No	24 Vac 4A res	No	24 Vac 4A res

Restrictions on ambient temperature for Valve Actuators

Fluid temperature in Valve Body	Maximum Allowable Ambient Temperature ^a
Chilled Water	122°F (50°C)
281°F (138°C)	113°F (45°C)
300°F (149°C)	107°F (42°C)
340°F (171°C)	100°F (38°C)

a - Minimum allowable ambient operating temperature 14°F (-10°C).

SpaceLogic M400 M800 and M1500 NSR Actuators

Specifications (continued)

Stroke	M800A, M1500A	U-Bolt style: >3/8" to 2" (9-52mm)
	M800A-VB, M1500A-VB	Screw Mount Style >3/8" to 1 7/8" (9-48mm)
	M400A, M400A-VB	U-Bolt and Screw Mount Style >3/8" to 1 1/4" (9-48mm)
Stroke timing	Floating: 60 or 300 sec selectable, Proportional: 15 sec @1/2" stroke	
Feedback AO	2 to 10 VDC	
Power supply type	Half Wave	
Motor type	Brushless DC	
Enclosure	NEMA 2 (IP 54, vertical mount only) with both conduit connectors used. NEMA 1 IP40 with one connector used	
Sound power level	Maximum 32 dba	
Ambient temperature storage	-13 °F to 149 °F (-25 to 65 °C) ambient	
Ambient temperature operational	122 °F (50 °C) For chilled water applications 113 °F (45 °C) ambient at 281 °F (138 °C) Fluid temperature 107 °F (42 °C) ambient at 300 °F (149 °C) Fluid temperature 100 °F (38 °C) ambient at 340 °F (171 °C) Fluid temperature 90 °F (32 °C) ambient at 366 °F (186 °C) Fluid temperature	
Minimum operating temperature	14 to 150 °F (-10 to 50 °C)	
Ambient humidity	15 to 95 % RH non-condensing	
Housing material	Die-Cast Aluminum	
Cover material	UL94 plenum rated plastic	
Agency listings	UL873, cULus, RCM, CE	

Restrictions on ambient temperature for Valve Actuators

Fluid temperature in valve body	Maximum allowable ambient temperature ^a
Chilled water	122°F (50°C)
281°F (138°C)	113°F (45°C)
300°F (149°C)	107°F (42°C)
340°F (171°C)	100°F (38°C)
366°F (186°C)	90°F (32°C)

a - Minimum allowable ambient operating temperature 14°F (-10°C).

Mounting

The actuator may be mounted horizontally, vertically, and in any position in between, but not upside down. Please note that to maintain NEMA 2 (IP54) rating the actuator must be mounted vertically.

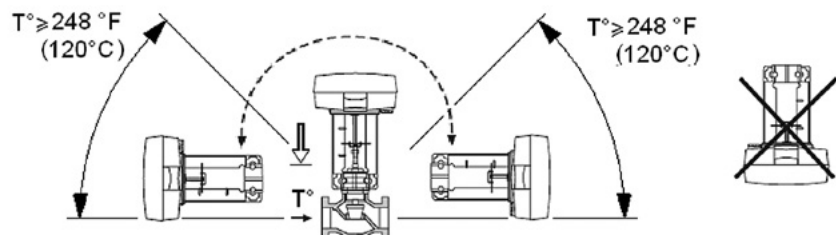

SpaceLogic M900Axx-VB SR Actuators

Applications

Schneider Electric Spring Return and Non-Spring Return **SpaceLogic** M900AxxVB series linear actuators mount directly onto ½"…2" VB-7000 series and obsolete VB-9xxx ½"…1¼" 2-Way and 3-Way globe valve bodies. Applications include chilled or hot water and steam, NEMA 1 or 2 (M900Axx-VB) or NEMA 4 (M900AxW-VB) models. Field selectable input signals include reverse and direct acting, floating or proportional 0…1 Vdc, 2…10 Vdc or 4…20 mAcd and proportional sequencing input signal ranges.

Applicable Literature

- Schneider Electric **SpaceLogic** M900A Datasheet, F-27682
- **SpaceLogic** M900A Installation Instructions, F-27683
- AV-821 Installation Instructions, F-27701
- CA-28 Control Valve Sizing, F-13755

Valve and Actuator Selection Procedure

1. Determine the required flow coefficient (Cv/kvs).

Using the required flow and pressure drop for the application, determine the required flow coefficient (consult CA28, F-13755 if necessary).

2. Determine valve body part number.

Select a 2-Way valve body from section 1.0 VB-7000 Valve Bodies having the required flow coefficient, size, body pattern, end connection, and temperature/pressure ratings appropriate for the application. Determine the desired loss of power position of the valve (M900AR-VB Spring retract, M900AE-VB Spring extend).

3. Select the SmartX Actuator and appropriate spring-return action.

Using the required close-off pressure for the application and the appropriate spring-return action, select a **SpaceLogic** actuator having sufficient close-off pressure on the valve body selected in step 2. Additional **SpaceLogic** actuator specifications may be found in Actuators and Linkages.

4. Determine the Assembly Part Number

If a complete factory valve and actuator assembly is required, consult the actuator code of the **SpaceLogic** actuator selected in Step 3. For the complete assembly part number:

- Change the valve body part number prefix from VB to VU.
- Insert the actuator code in the third field of the part number.
- Confirm the factory assembly is available.

Example:

- Valve Body: VB-7253-0-4-4
- Actuator: M900AR-VB
- Complete Assembly: VU-7253-650-4-4

Note: Not available as a factory assembly, order the valve body and actuator for field assembly.

SpaceLogic actuators are field configured for the desired control signal type and range plus the desired action. Consult the appropriate **SpaceLogic** Installation Instructions for further information.

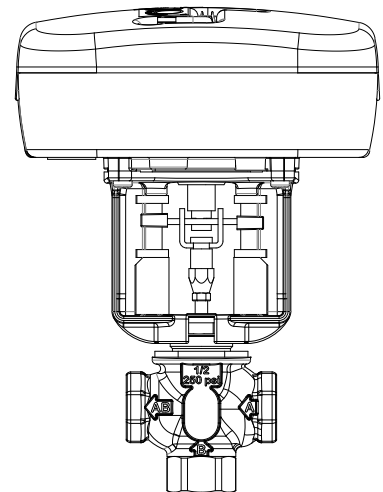

SpaceLogic M900Axx(-VB) SR & VB-7000 Valve Selection

Not all valve body and actuator combinations are available factory-assembled. Some combinations must be field-assembled. Select a Valve Actuator combination having sufficient close off for the application.

Select VB-7000 Valve / M900Axx(-VB) ^a Spring Return Actuator				
Valve Body ^{ac}	Valve Action	P-Code	Size	Close-off Ratings PSI M900Axx ^b
VB-7211-0-3-P VB-7211-0-4-P VB-7212-0-4-P VB-7214-0-4-P VB-7213-0-4-P VB-7253-0-4-P VB-7273-0-4-P	Stem up Open	1, 2, 3, 4	½"	250
		5, 6	¾"	250
		7, 8	1"	180
		9	1 1/4"	110
		10	1 ½"	75
		11	2"	40
		VB-7221-0-4-P VB-7222-0-4-P VB-7224-0-4-P VB-7223-0-4-P VB-7263-0-4-P VB-7283-0-4-P	Stem up Closed	1, 2, 3, 4
5, 6	¾"			250
7, 8	1"			180
9	1 1/4"			110
10	1 ½"			75
11	2"			40
VB-7312-0-4-P VB-7313-0-4-P VB-7314-0-4-P	3 Way Mixing			2, 4
		6	¾"	250
		8	1"	180
		9	1 1/4"	110
		10	1 ½"	75
		11	2"	40
VB-7323-0-4-P	3 Way Diverting	4	½"	250
		6	¾"	250
		8	1"	250
		9	1 1/4"	250
		10	1 ½"	250
		11	2"	250
VBS-9263-0-4-P	Stem Up Closed	1-7, 31-39	½"	250
		5, 6, 45	¾"	250

a - Substitute VU- for VB- and add the actuator code 650 (M900AR-VB) or 660 (M900ARW-VB) to substitute for the -0-

b - M900Axx-VB or M900Axx Styles

c - Not all valve styles are available in all sizes or "P" codes.

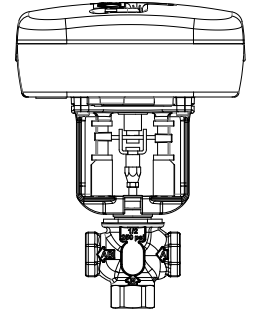

SpaceLogic M900A-VB Valve Actuator Mounted on a 3-Way VB-7000 Series Valve

SpaceLogic M900A Factory & Field Assembly SR Models

Spring Return SpaceLogic Factory Assemblies Model Table

Model	Actuator Code	Force	Power	Running Watts	Transformer Size	Floating Control ^a	Proportional Control ^b	Feedback Voltage ^a	(2) SPDT Aux Switches ^c	Spring Return Action
M900AR-VB	650	157 lbf (700 N)	24 Vac 50/60 Hz 20...30 Vdc 1.5 A	21	50 Va	Yes	0...1 Vdc, 2...10 Vdc, 4...20 Ma	2...10 Vdc or 0-5 Vdc	No	Retract
M900ARW-VB	660									

a - Dip switch selectable.
 b - 0...5, 2...6 or 5...10, 6...10 also selectable by dip switch.
 c - S2 auxiliary switches may be added in the field order 880 0104 000.
 NOTE: Suffix W= NEMA 4 Weather

Spring Return SpaceLogic Actuators for Field Assembly

Model	VB-7000 Mounting Kit Required	Force	Power	Running Watts	Transformer Size	Floating Control ^a	Proportional Control ^b	Feedback Voltage ^a	(2) SPDT Aux Switches ^c	Spring Return Action
M900AR	AV-821	157 lbf (700 N)	24 Vac 50/60 Hz 20...30 Vdc 1.5 A	21	50 Va	Yes	0...10 Vdc, 2...10 Vdc, 4...20 Ma	2...10 Vdc or 0-5 Vdc	No	Retract
M900AE										Extend
M900AR-VB	None									Retract
M900ARW	AV-821									
M900ARW-VB	None									Retract
M900ARW-S2	AV-821									
M900AEW-S2		Extend								

a - Dip switch selectable.
 b - 0...5, 2...6 or 5...10, 6...10 also selectable by dip switch.
 c - S2 auxiliary switches may be added in the field. Order 880 0104 000.
 NOTE: Suffix W= NEMA 4 Weather

Note: When installing valve and actuator assemblies, observe the minimum and maximum fluid and ambient temperature limits shown .

Mx51-710x 105 lbf Linear SR SmartX Actuators

Mx51-7103 Series
SmartX Actuators
24 Vac
105 lbf (467 N)

MA51-7100
MA51-7101
SmartX Actuators
120 Vac/230 Vac
105 lbf (467 N)



More information:
Scan the QR code or visit
the link below for more
information.



Visit:

<http://goo.gl/amkgWe>

Specifications

Connection	3 ft. (0.9 m) plenum cable	
Housing	Polymer, NEMA 2	
Dimensions	6-5/16 x 6¾ x 3½ (160 x 170 x 90 mm)	
Position indicator	Visual indicator	
Override	Manual	
Control signal	MA51-7103-100 MF51-7103-100 MS51-7103-100: 2 to 10 VDC MS51-7103-130: 6 to 9 VDC MS51-7103-140: 6 to 9 VDC MS51-7103-150: 0 to 10 VDC MS51-7103-160: 4 to 20 mAdc The Control signal is factory set for direct action. It can be field-adjusted for reverse action.	2-position SPST
Voltage	24 Vac ± 20%, 20 to 30 VDC	MA51-7100: 120 Vac ± 10% MA51-7101: 230 Vac ± 10%
VA@60 HZ	MA51-7103-100: 5.3 MF51-7103-100: 6.9 MS51-7103-100: 6.6	MA51-7100: 7.9 MA51-7101: 7.4
Watts @ 60 Hz	4.7	MA51-7100: 6.2 MA51-7101: 5.4
Auxiliary switch	None	
Timing (seconds)	MA: Powered approx. 27 spring return approx. 19 MF/MS: Powered <60 spring return <16	Powered approx. <27 spring return approx. <19
Feedback	For voltage ranges, feedback & input signal ranges are the same. 4 to 20 mA input range has a 2 to 10 VDC position feedback signal. MS51-7103-140 has no feedback output. MF51-7103-100 has a 2 to 10VDC output.	None
Installation instructions	F-27169	

Mx51-720x 220 lbf Linear SR SmartX Actuators

Mx51-7203 Series
SmartX Actuators
24 Vac
220 lbf (979 N)

MA51-7200
MA51-7201
SmartX Actuators
120 Vac/230 Vac
220 lbf (979 N)



Specifications

Connection	3 ft. (0.9 m) plenum cable	
Housing	Aluminum die-cast, NEMA 2	
Dimensions	7 x 10-5/8 x 2-9/16 (178 x 270 x 65 mm)	
Position indicator	Visual indicator	
Override	Manual	
Control signal	MA51-7203: 2-position SPST MF51-7203: Floating MS51-7203: 2 to 10 VDC MS51-7203-040: 6-9 VDC MS51-7203-050: 0 to 10 VDC The Control signal is factory set for direct action. It can be field-adjusted for reverse action.	MA51-7200: 2-position SPST
Voltage	24 Vac \pm 20%, 22 to 30 VDC	MA51-7200: 120 Vac \pm 10% MA51-7201: 230 Vac \pm 10%
VA@60 HZ	9.7	MA51-7200: 10 MA51-7201: 10.6
Watts @60 Hz	MA51-7203: 7.5 MF51-7203: 7.7 MS51-7203: 7.4	MA51-7200: 8.4 MA51-7201: 8.5
Auxiliary switch	None	
Timing (seconds)	Powered <100 Spring return <35	
Feedback	MA51 & MF51: None MS51: 2 to 10 VDC only The MS51-7203-040 does not have a feedback output.	None
Installation instructions	F-27120	

Mx40-704x 35 lb-in SR SmartX Actuators

Mx40-704x Series
SmartX Actuators
24 Vac
35 lb-in (4 N-m)



Specifications

Connection	3 ft. (0.9 m) plenum cable		
Rotation	Aluminum die-cast, NEMA 2		
Control action	7 x 10-5/8 x 2-9/16 (178 x 270 x 65 mm)		
Shaft size	Visual indicator		
Housing	Manual		
Dimensions	MA51-7203: 2-position SPST MF51-7203: Floating MS51-7203: 2 to 10 VDC MS51-7203-040: 6-9 VDC MS51-7203-050: 0 to 10 VDC The Control signal is factory set for direct action. It can be field-adjusted for reverse action. MA51-7200: 2-position SPST		
Overload protection	24 Vac ± 20%, 22 to 30 VDC MA51-7200: 120 Vac ± 10% MA51-7201: 230 Vac ± 10%		
Angle of rotation	9.7 MA51-7200: 10 MA51-7201: 10.6		
		Position indicator	MA51-7203: 7.5 MF51-7203: 7.7 MS51-7203: 7.4 MA51-7200: 8.4 MA51-7201: 8.5
		Built-in Auxiliary switch	None
		Override	Powered <100 Spring return <35
		Linkages	MA51 & MF51: None MS51: 2 to 10 VDC only The MS51-7203-040 does not have a feedback output. None
		Installation instructions	F-27120
		Regulatory compliance	c-UL-us LISTED for safety per UL 873 and CAN C22.2 No.24-93. CE mark compliant per EU directives LVD, EMC, and RoHS2. AUS/NZ marked RCM.

Electrical Specifications

Part Number	Actuator Inputs			Outputs		Approx. Timing (sec)		Weight lbs (kg)
	Control	Voltage	VA @ 60 Hz	Feedback	Auxiliary Switch	Powered	Spring Return	
MA40-7043	2-Position	24 Vac ± 20% 22-30 Vdc	4.4	None	No	<50	<26	4.3 (1.9)
MA40-7043-501					One			
MF40-7043	Floating		5.9		No	<130	<25	
MF40-7043-501					One			
MS40-7043	Proportional 2...10 Vdc 4...20 mAa		5.6	2...10 Vdc	No	<130	<25	
MS40-7043-501					One			
MS40-7043-MP ^a	Proportional 6...9 Vdc	6.6	None	No	<130	<25		
MS40-7043-MP5 ^a				One				

a - Provides auxiliary power supply +20 Vdc 25 mA maximum.

Application

The AM-708 500 ohm resistor converts a 4 to 20 mA signal to a 2 to 10 VDC signal.

Specifications

- Actuators: MS40-7043, MS41-7073, MS41-7153, MS40-717x, MS41-6083, MS41-6153 and MS41-6343.
- Wire leads.



AM-708
500 Ohm
Resistor

Mx40-704x 35 lb-in SR SmartX Actuators

Mx40-704x Spring Return Actuator Specifications

Inputs

Control signal	MA40-704x – ON/OFF SPST control contacts or Triacs (500 mA rated) MS40-7043 – Proportional, 2 to 10VDC or 4 to 20 mAdc with 500 Ω resistor. MS40-7043-MP/-MP5 – Proportional 6 to 9 VDC. MF40-7043 – Floating point control, 24 Vac.																																																																								
Power requirements	<p>All 24 Vac circuits are Class 2.</p> <table border="1"> <thead> <tr> <th rowspan="3">Part Number^a</th> <th rowspan="3">Voltage 50/60 Hz</th> <th colspan="4">Running</th> <th colspan="2">Holding</th> </tr> <tr> <th colspan="2">50 Hz</th> <th colspan="2">60 Hz</th> <th>50 Hz</th> <th>60 Hz</th> </tr> <tr> <th>VA</th> <th>W</th> <th>VA</th> <th>W</th> <th>W</th> <th>W</th> </tr> </thead> <tbody> <tr> <td>MA40-7043</td> <td rowspan="6">24 Vac ± 20%</td> <td>4.4</td> <td>2.9</td> <td>4.4</td> <td>2.9</td> <td>0.8</td> <td>0.8</td> </tr> <tr> <td>MS40-7043</td> <td>5.6</td> <td>4.2</td> <td>5.6</td> <td>4.2</td> <td>2.4</td> <td>2.4</td> </tr> <tr> <td>MF40-7043</td> <td>5.9</td> <td>4.4</td> <td>5.9</td> <td>4.4</td> <td>2.9</td> <td>2.9</td> </tr> <tr> <td>MS40-7043-MP</td> <td>6.9</td> <td>5.0</td> <td>6.6</td> <td>5.0</td> <td>3.2</td> <td>3.2</td> </tr> <tr> <td>MS40-7043-MP5</td> <td></td> <td></td> <td></td> <td></td> <td></td> <td></td> </tr> <tr> <td>MA40-7040</td> <td>120 Vac ± 10%</td> <td>6.4</td> <td>3.8</td> <td>4.3</td> <td>3.4</td> <td>1.6</td> <td>1.2</td> </tr> <tr> <td>MA40-7041</td> <td>230 Vac ± 10%</td> <td>5.8</td> <td>4.1</td> <td>4.6</td> <td>3.9</td> <td>1.5</td> <td>1.2</td> </tr> </tbody> </table> <p>a - See Auxiliary switches under Electrical below.</p>	Part Number ^a	Voltage 50/60 Hz	Running				Holding		50 Hz		60 Hz		50 Hz	60 Hz	VA	W	VA	W	W	W	MA40-7043	24 Vac ± 20%	4.4	2.9	4.4	2.9	0.8	0.8	MS40-7043	5.6	4.2	5.6	4.2	2.4	2.4	MF40-7043	5.9	4.4	5.9	4.4	2.9	2.9	MS40-7043-MP	6.9	5.0	6.6	5.0	3.2	3.2	MS40-7043-MP5							MA40-7040	120 Vac ± 10%	6.4	3.8	4.3	3.4	1.6	1.2	MA40-7041	230 Vac ± 10%	5.8	4.1	4.6	3.9	1.5	1.2
Part Number ^a	Voltage 50/60 Hz			Running				Holding																																																																	
				50 Hz		60 Hz		50 Hz	60 Hz																																																																
		VA	W	VA	W	W	W																																																																		
MA40-7043	24 Vac ± 20%	4.4	2.9	4.4	2.9	0.8	0.8																																																																		
MS40-7043		5.6	4.2	5.6	4.2	2.4	2.4																																																																		
MF40-7043		5.9	4.4	5.9	4.4	2.9	2.9																																																																		
MS40-7043-MP		6.9	5.0	6.6	5.0	3.2	3.2																																																																		
MS40-7043-MP5																																																																									
MA40-7040		120 Vac ± 10%	6.4	3.8	4.3	3.4	1.6	1.2																																																																	
MA40-7041	230 Vac ± 10%	5.8	4.1	4.6	3.9	1.5	1.2																																																																		
Connections	MA40-704x and MA40-704x-501 – 3 ft. (0.9 m) long appliance cables, ½" conduit connector. For M20 Metric conduit, use AM-756 adapter. MF40-7043 and MF40-7043-501, MS40-7043 and MS40-7043-501 – 3 ft. (0.9 m) long, plenum rated cables, ½" conduit connector. For M20 Metric conduit, use AM-756 adapter.																																																																								
Motor type	MA40-704x – Brush. MF40-7043, MS40-7043 – Brushless DC.																																																																								
Outputs: Electrical	<p>Auxiliary switches: One Auxiliary switch available with Mx40-7043-501 and MS40-7043-MP5, SPDT 6A resistive @ 24 Vac, adjustable 0 to 95° (0 to 1 scale). Switch meets VDE requirements for 6 (1.5)A, 24 Vac. One Auxiliary switch available with MA40-7040-501 or MA40-7041-501, SPDT 6A resistive @ 250 Vac, adjustable 0 to 95° (0 to 1 scale). Switch meets VDE requirements for 6 (1.5)A, 250 Vac. Position Feedback Voltage "AO" (MS40- model only): 2 to 10 VDC (maximum 0.7 mA) output signal for position feedback or operation of up to four slave actuators. Control Mode: Switch provided for selection of direct acting or reverse acting control mode on proportional models. Timing: MA40-704x - Approx. 50 sec. MF40- and MS40-7043 - Approx. 130 sec. Auxiliary Power Supply: MS40-7043-MP and MS40-7043-MP5 +20 VDC @ 25 mA (max.)</p>																																																																								
Mechanical	<p>Stroke: Angle of rotation is limited to a maximum of 95°, with mechanical stop. Output torque rating: Mx40-704x 35 lb-in (4 N-m) Position indicator: Visual indicator with a scale numbered from 0 to 90°, provided for Position indication.</p>																																																																								
Environment temperature limits	Shipping and storage: -40 to 160 °F (-40 to 71 °C) ambient. Operating: -22 to 140 °F (-30 to 60 °C).																																																																								
Humidity	5 to 95% RH, non-condensing																																																																								
Location	NEMA Type 2 (IEC IP54)																																																																								

Mx41-7073 60 lb-in SR SmartX Actuators

Mx41-7073 Series SmartX Actuators
24 Vac
60 lb-in



Specifications

Torque	60 lb-in (7 N-m) minimum
Connection	3 ft. (0.9 m) cable, ½" conduit connectors
Rotation	CW or CCW spring return using reverse mounting
Control action	Direct/reverse signal selection (MS41- only)
Shaft size	¾" (19 mm) diameter, ½" (13 mm) square
Housing	NEMA 1, NEMA 2 (IEC IP54) with conduit connector in the down position
Dimensions	10½ x 4 x 3½" (287 x 100 x 89 mm)
Overload protection	Throughout rotation
Angle of rotation	93° nominal
Position indicator	Pointer and scale
Built-in Auxiliary switch	2-SPDT 7A on MA41-7073-502, MF41-7073-502, MS41-7073-502 only
Override	Manual
Motor type	All brushless DC except MA41-7073-brush
Linkages	AV-602
Installation instructions	MA41-7073: F-26642, MF41-7073: F-26644, MS41-7073: F-26645
Regulatory compliance	c-UL-us LISTED for safety per UL 873 and CAN C22.2 No.24-93. CE mark compliant per EU directives LVD, EMC, and RoHS2. AUS/NZ marked RCM.

Electrical specifications

Part Number	Actuator inputs			Outputs		Approx. Timing in seconds		Weight lbs (kg)			
	Control	Voltage	VA @ 60 Hz	Feedback	Auxiliary switch	Powered	Spring Return				
MA41-7073	2-Position	24 Vac ± 20% 22-30 VDC	4.8	None	No	<80	<40	6.8 (3.1)			
MA41-7073-502					Two				7.0 (3.2)		
MF41-7073	Floating 24 Vac		6.2		None	No	<195	<30	6.5 (2.9)		
MF41-7073-502						Two			7.0 (3.2)		
MS41-7073	2 to 10 VDC 4 to 20 mA dca		5.8		2 to 10 VDC	No			<195	<30	6.5 (2.9)
MS41-7073-502						Two					7.0 (3.2)

Application

The AM-708 500 ohm resistor converts a 4 to 20 mA signal to a 2 to 10 VDC signal.

AM-708
500 Ohm
Resistor



Specifications:

- Actuators: MS40-7043, MS41-7073, MS41-7153, MS40-717x, MS41-6083, MS41-6153 and MS41-6343.
- Wire leads.

Mx41-707x/715x 60/133 lb-in SR SmartX Actuators

Mx41-707x & Mx41-715x Series SmartX Actuators
 24 to 230 Vac
 60/133 lb-in



Spring Return Actuator

Specifications

Control signal	MA41-707x, MA41-715x – ON/OFF SPST control contacts or Triacs (500 mA rated). MF41-7073, MF41-7153 – Floating point control, 24 Vac. MS41-7073, MS41-7153 – Proportional, 2 to 10 VDC or 4 to 20 mAdc with 500 Ω resistor.							
Power requirements	All 24 Vac circuits are Class 2.							
	Part Number	Voltage 50/60 Hz	Running				Holding	
			50 Hz	60 Hz	50 Hz	60 Hz	50 Hz	60 Hz
			VA	W	VA	W	W	W
	MA41-7153-xxx		9.8	7.5	9.7	7.5	2.8	2.8
	MS41-7153-xxx	24 Vac ± 20%	9.8	7.4	9.7	7.4	2.9	2.9
	MF41-7153-xxx		9.8	7.7	9.7	7.7	3.3	3.3
	MA41-7150-xxx	120 Vac ± 10%	11.7	8.8	10.0	8.4	3.6	5.0
	MA41-7151-xxx	230 Vac ± 10%	15.5	9.5	10.6	8.5	4.6	3.3
	MA41-7073-xxx		4.8	3.2	4.8	3.2	0.8	0.8
MS41-7073-xxx	24 Vac ± 20%	5.8	4.6	5.8	4.6	2.3	2.3	
MF41-7073-xxx		6.2	4.8	6.2	4.8	2.8	2.8	
MA41-7070-xxx	120 Vac ± 10%	10.7	4.2	5.6	3.6	2.0	1.2	
MA41-7071-xxx	230 Vac ± 10%	17.0	5.1	8.0	4.0	2.7	1.4	
Connections	3 ft. (0.9 m) long appliance cable, ½" conduit connectors. For M20 metric conduit, use AM-756 adapter.							
Motor type	MA41-707x – Brush. MA41-715x, MF41-7073, MF41-7153, MS41-7073, MS41-7153 – Brushless DC.							
Electrical	Auxiliary switches: Two Auxiliary switches available with Mx41-715x-502, and Mx41-707x-502, SPDT 7A resistive @ 24 Vac, one fixed @ 5° and one adjustable 25 to 85°. Switches meet VDE requirements for 7 (2.5)A, 24 Vac. Position Feedback Voltage "AO" (MS41- model only): 2 to 10 VDC (maximum 0.5 mA) output signal for position feedback or operation of up to four slave actuators. Control Mode: Switch provided for selection of direct acting or reverse acting control mode on proportional models. Timing: MA41-707x - Approx. 80 sec. MF41 and MS41-7073 - Approx. 195 sec. Mx41-715x - Approx. 190 sec.							
Mechanical	Stroke: Angle of rotation is limited to a maximum of 95°, with mechanical stop. Output torque rating: Mx41-707x- 60 lb-in (7 N-m), Mx41-715x- 133 lb in (15 N-m). Position indicator: Visual indicator with a scale numbered from 0 to 90°, provided for Position indication. Manual override: Rotation is adjustable from -5° to 85° by using manual override crank.							
Environment temperature limits Humidity	Shipping and storage: -40 to 160 °F (-40 to 71 °C) ambient. Operating: -22 to 140 °F (-30 to 60 °C). 5 to 95% RH, non-condensing							
Location	NEMA Type 2 (IEC IP54) with conduit connector in the down position.							
Regulatory compliance	RoHS and REACh							

Mx40-717x 150 lb-in SR SmartX Actuators

Mx40-717x Series SmartX Actuators
150 lb-in (17 N-m)



Spring Return Actuator

Specifications

Connection	2 ft. (61 cm) Appliance cable, ½" conduit connectors
Rotation	CW or CCW spring return using reverse mounting
Shaft size	Standard: 3/8 to ½" (10 to 13 mm) round or square Optional: 1.05" (25.1 mm) diameter, 5/8" (15.9 mm) square
Housing	NEMA 1, NEMA 4 (IEC IP56) with customer-supplied water-tight connector
Dimensions	10-7/8 x 4 x 4" (276 x 100 x 100 mm)
Overload protection	Throughout rotation
Angle of rotation	93° nominal
Position indicator	Visual indicator
Built-in auxiliary switches	None
Override	None
Motor type	Brushless DC
Linkages	AV-602
Installation instructions	MA40-717x: F-26742, MF40-7173: F-26749, MS40-717x: F-26748
Regulatory compliance	c-UL-us LISTED for safety per UL 873 and CAN C22.2 No.24-93. CE mark compliant per EU directives LVD, EMC, and RoHS2. AUS/NZ marked RCM.

Electrical specifications

Part number	Actuator inputs			Outputs		Approx. Timing in seconds		Weight lbs (kg)
	Control	Voltage	VA @ 60 Hz	Feedback	Auxiliary switch	Powered	Spring Return	
MA40-7170	2-Position	120 Vac ± 10%	11.4	None	No	<162	10.5 (4.8)	
MA40-7173		24 Vac ± 20%	9.6					
MF40-7173	Floating		10.0					
MS40-7170a	2 to 10 VDC 4 to 20 mA ^b	120 Vac ± 10%	11.1					
MS40-7173	2 to 10 VDC	24 Vac ± 20%	9.4					
MS40-7171		240 Vac ± 10%						

a - The CE directive is not applicable to this model.

b - With the addition of a 500 ohm resistor.

Application

The AM-708 500 ohm resistor converts a 4 to 20 mA signal to a 2 to 10 VDC signal.

Specifications:

- Actuators: MS40-7043, MS41-7073, MS41-7153, MS40-717x, MS41-6083, MS41-6153 and MS41-6343.
- Wire leads.



Mx41-6043 44 lb-in NSR SmartX Actuators

Mx41-6043 Series SmartX Actuators
24 Vac 44 lb-in (5 N-m)



Non-Spring Return Actuator

Specifications

Connection	3 ft. (0.9 m) 18 AWG leads, Plenum rated
Rotation	90° CW or CCW field selectable
Shaft size	3/8 to 5/8" (10 to 15.9 mm) diameter, 1/4 to 1/2" (6.4 to 13 mm) square, 9/16" (14.3 mm) hex
Housing	NEMA 2, (IP54 to EN60529) with conduit in the down position
Dimensions	5-7/16 x 2 3/4 x 3-3/8" (140 x 70 x 60 mm)
Overload protection	Throughout rotation
Angle of rotation	90° nominal (field-adjustable to limit travel on either end of stroke)
Position indicator	Adjustable pointer
Built-in auxiliary switches	(Use MF41-6083-502 and MS41-6083-502 models with Auxiliary switches.)
Operating temperature limits	-25 to 130°F (-32 to 55°C)
Override	Manual
Linkages	AV-611
Installation instructions	MF41-6043: F-27213, MS41-6043: F-27214
Regulatory compliance	c-UL-us LISTED per UL 873 and CAN C22.2 No.24-93. CE compliant to directives LVD, EMC, and RoHS2.

Electrical specifications

Part number	Actuator inputs			Outputs	Approximate Timing in seconds	Weight lbs (kg)
	Control	Voltage	VA @ 60 Hz	Feedback		
MF41-6043	Floating	24 Vac +20% -15%	2.3	None	<90	1.06 (0.5)
MS41-6043	0 to 10 VDC			0 to 10 VDC		

Mx41-6083 88 lb-in NSR SmartX Actuators

Mx41-6083 Series SmartX Actuators
 24 Vac
 88 lb-in (10 N-m)



Non-Spring Return Actuator

Specification

Connection	3 ft. (0.9 m) 18 AWG leads, Plenum rated
Rotation	90° CW or CCW field selectable
Shaft size	3/8 to 5/8" (10 to 15.9 mm) diameter, 1/4 to 1/2" (6.4 to 13 mm) square, 9/16" (14.3 mm) hex
Housing	NEMA 2, (IP54 to EN60529) with conduit in the down position
Dimensions	5-7/16 x 2 3/4 x 3-3/8" (140 x 70 x 60 mm)
Overload protection	Throughout rotation
Angle of rotation	90° nominal (field-adjustable to limit travel on either end of stroke)
Position indicator	Adjustable pointer
Built-in auxiliary switches	Two SPDT on MF41-6083-502, MS41-6083-522, MS41-6083-502 only
Operating temperature limits	-25 to 130°F (-32 to 55°C)
Override	Manual
Linkages	AV-611
Installation instructions	MF41-6083: F-27213, MS41-6083: F-27214
Regulatory compliance	c-UL-us LISTED per UL 873 and CAN C22.2 No.24-93. CE compliant to directives LVD, EMC, and RoHS2.

Electrical Specifications

Part number	Actuator inputs			Outputs		Approximate Timing in seconds Powered	Weight lbs (kg)
	Control	Voltage	VA @ 60 Hz	Feedback	Auxiliary switch		
MF41-6083	Floating	24 Vac +20% -15%	2.3	None	No	<125	1.06 (0.5)
MF41-6083-502				None	Two		
MS41-6083	0 to 10 VDC		3.3	0 to 10 VDC	No		
MS41-6083-502	0 to 10 VDC				Two		

Mx41-6153 133 lb-in NSR SmartX Actuators

Mx41-6153 Series SmartX Actuators
 24 Vac
 133 lb-in (15 N-m)



Non-Spring Return Actuator

Specifications

Connection	3 ft. (0.9 m) 18 AWG leads
Rotation	CW or CCW through reverse mounting
Shaft size	3/8 to 3/4" (6.4 to 19 mm) diameter, 1/4 to 1/2" (6.4 to 13 mm) square
Housing	NEMA 1, (IP54 to EN60529)
Dimensions	8-3/8 x 3 1/4 x 2-2/3" (210 x 80 x 70 mm)
Overload protection	Throughout rotation
Angle of rotation	90° nominal (field-adjustable to limit travel on either end of stroke)
Position indicator	Adjustable pointer
Built-in auxiliary switches	Two SPDT on MS41-6153-502 only
Operating temperature limits	-25 to 130°F (-32 to 55°C)
Override	Manual
Linkages	AV-611
Installation instructions	F-27215
Regulatory compliance	c-UL-us LISTED per UL 873 and CAN C22.2 No.24-93. CE compliant to directives LVD, EMC, and RoHS2.

Electrical specifications

Part number	Actuator inputs			Outputs		Approximate Timing in seconds	Weight lbs (kg)
	Control	Voltage	VA @ 60 Hz	Feedback	Auxiliary switch		
MF41-6153	Floating	24 Vac +20% -15%	3.0	None	No	<125 (60 Hz)	2.2 (1)
MS41-6153	0 to 10 VDC			0 to 10 VDC	2		
MS41-6153-502							

AV-602 Linkage

Application

The AV-602 links Schneider Electric rotary actuators to 1" to 2" VB-7000 globe valves.

AV-602 Actuator/Valve combinations

Actuator	Factory - Assemble Valve sizes 2-Way & 3-Way	Field - Assembled to VB Valve Bodies 2-Way & 3-Way
Mx41-707x Mx41-715x Mx40-717x	1½ to 2"	1 to 2"

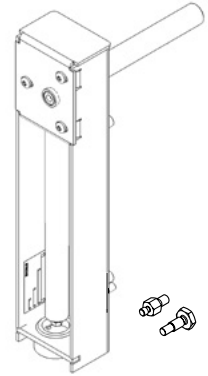

AV-602 Globe Linkage

Specifications

Motor mounting: In any upright position with the motor above center the line of the valve body.

Actuator/valve combinations

Actuator	Globe Valve	SR
Mx41-707x	1 to 2"	SR (Spring Return)
Mx41-715x	1¼" to 2"	
Mx40-717x	1½ to 2"	

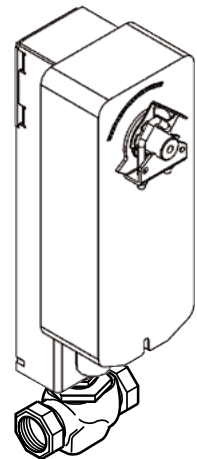

Typical Actuator/Linkage Mounting

AV-611 Linkage

Application

The AV-611 linkage connects SmartX Actuator Mx4x-60x3 or 6153 non-spring return and Mx40-704x spring return actuators (listed below) to ½" to 2" VB-7000 and ½" to 1¼" discontinued VB-9xxx 2-Way and 3-Way globe valves.

Applicable literature

- Mx41-6043, Mx41-6083 Series non-spring return Actuator installation instructions, F-27213.
- Mx41-6153 Series Non-spring return Actuator installation instructions, F-27215.
- MA40-704x, MA4x-707x, MA4x-715x Series spring return Actuator installation instructions, F-26642.
- MF40-7043, MF4x-707x, MF4x-715x Series spring return Actuator installation instructions.
- Vx-7000 & Vx-9000 Series Mx41-6xxx & Mx4x-7000 Series Linked Globe Valve Assemblies Selection Guide, F-26752.

Actuators

Actuator	Description	Size
MF41-6043	Floating 44 lb-in non-spring return	½" to 2"
MS41-6043	Proportional 44 lb-in non-spring return	
MF41-6083	Floating 88 lb-in non-spring return	1" to 2"
MS41-6083	Proportional 88 lb-in non-spring return	
MF41-6153	Floating 133 lb-in non-spring return	1½" to 2"
MS41-6153	Proportional 133 lb-in non-spring return	
MA40-704x	Two-position 35 lb-in spring return	½" to 2"
MF40-7043	Floating 35 lb-in spring return	
MS40-7043	Proportional 35 lb-in spring return	

Note: The AV-611 linkage is also compatible with the actuators above with the A

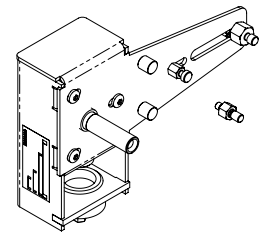

AV-611 SmartX Actuator Globe Linkage

Linkage Kits for Field Mounting Globe Valve Actuators

Linkage Kit	Actuator	Factory-assembled valve sizes 2-way & 3-way	Field-assembled to VB valve bodies 2-way & 3-way
AV-611	Mx41-6043	½" to 2"	½" to 2"
	Mx41-6083	1" to 2"	
	Mx41-6153	1½" to 2"	

a - Refer to linkage pages for complete details.

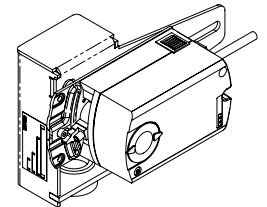

Typical Actuator Mounting

MA-52xx Hydraulic 2-Position SR Actuators

Application

These MA-52xx Series Actuators are used for two-position control of valves that require a return to the normal position upon power interruption.

Features

- Two-position actuators controlled by SPST controller
- Spring return
- 24 Vac and 120 Vac models are available
- An actuator with the part number suffix "-500" has a built-in, adjustable, SPDT Auxiliary switch
- Die cast lower housing with ½" conduit opening and painted steel upper housing
- Hydraulic actuator with oil-immersed motor and pump

Model table

Part number	Actuator power input				10 amps aux switch	Timing in seconds @ 72° F (22° C)		
	AC voltage +10 -15%	60 Hz		50 Hz		To extend (no load stroke)	Retract on power loss	
		Watts	Amps	Watts				Amps
MA-5210	120	5.4	0.14	6.0	0.17	60	15	
MA-5210-500								No
MA-5213	24	8.8	0.65	9.8	0.80			No
MA-5213-500								Yes

Specifications

Inputs	
Control circuit	Two-wire, SPDT
Power input	Refer to Model table
Connections	Color-coded 4 ft. (1.2 m) leads.
Outputs	
Electrical	Auxiliary switch (MA-5xxx-500 models), 10 Amps, 120 Vac adjustable SPDT, factory set to close the N.C. contact at the retracted end of stroke.
Mechanical	Stroke, Valve: Approximately 9/16" (14.3 mm) from fully retracted to fully extended
Environment	
Temperature limits	Shipping & storage, -40 to 140° F (-40 to 61° C) Operating, -20 to 140° F (-29 to 60° C) Operating, damper -20 to 140° F (-29 to 60° C) Operating, valve: refer to restrictions on maximum allowable ambient air temperature for Valve Actuators table (next page).
Humidity	5 to 95% RH, non-condensing
Location	NEMA Type 1
Dimensions	6¾ x 3-23/32 x 3¼ Dia." (171 x 94 x 83 mm)
Regulatory compliance	RoHS and REACH

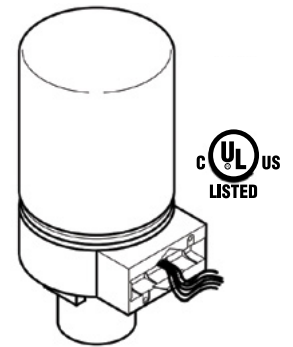

MA-52xx Spring Return Series

MA-52xx Hydraulic 2-Position SR Actuators

Restrictions on Maximum Allowable Ambient Air Temperature for Valve Actuators

Temperature of media in the valve body (Check the rating of the valve) °F (°C)	Maximum ambient temperature of MA-521x Series	
	AV-7600-1 (Only) °F (°C)	AV-7600-1 and AV-601 °F (°C)
366 (180)	90 (32)	90 (32)
340 (171)	100 (38)	100 (38)
281 (138)	115 (46)	140 (60)a
181 (83)	140 (60)a	140 (60)a
80 (26)	140 (60)a	140 (60)a

a - Maximum ambient temperature of the actuator must never exceed 140° F (60° C).

Optional Accessories

Linkages

AV-601	Linkage extension for hot water and steam applications; use with AV-7600.
AV-7600-1	Linkage ½" to 2" to be used with VB-7000.

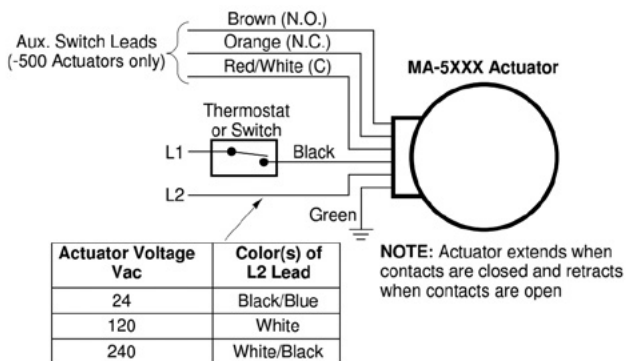

Typical Wiring for MA-5xxx Series Actuators

Application

The AV-7600-1 Linkage kit is used to field assemble MA-521x, MP-521x, MP-541x and MP-561x round hydraulic actuators to ½" through 2" VB-7000 series valve bodies.

Features

- Provides direct-couple interface between MA, MP and MPR-5xxx actuators and valve bodies
- Fits all VB-7000 series valve bodies
- Includes spring choices for higher 2-Way valve close off

Specifications

- Actuator mounting: In any upright position above the center line of the valve body. For steam applications only, mount the actuator above the valve body at 45° from vertical.

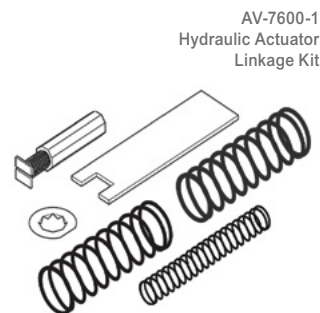

AV-7600-1 Hydraulic Actuator Linkage Kit

MP-52xx Hydraulic Proportional SR Actuators

Application

These MP-52xx Series actuators provide electronic proportional control of valves requiring the return to normal position upon power interruption.

Features

- Compatibility with 2 to 15 VDC System 8000 Input signals
- Proportional control by variable VDC Input signal
- Spring return
- Fixed 3 VDC operating span
- Non-adjustable start point and non-positive positioning. Typically, one actuator is controlled from one VDC output signal
- 10,000 Ω or greater input impedance
- 24 and 120 Vac models
- Die cast lower housing with 1/2" (12.7 mm) conduit opening and painted steel upper housing
- Hydraulic actuator with oil-immersed motor, transducer, and pump

Model Table

Part number	Actuator power input					10 amps auxiliary switch ^a	Timing in seconds @ 72° F (22° C)			Required Linkage
	AC voltage $\pm 10\%$	60 Hz		50 Hz			To extend (no load stroke)	To Retract	Retract on Power Loss	
		Watts	Amps	Watts	Amps					
MP-5210	120	11.7	0.16	12.9	0.19	No	60	40	15	AV-7600-1 AV-601 ^b
MP-5210-500						Yes				
MP-5213	24	12.0	0.80	13.2	0.97	No				
MP-5213-500						Yes				

a - Common of switch is in series with AC power supply to the motor. Therefore, the switch must be wired to control the same voltage as the actuator itself.

b - May be required for steam or hot water.

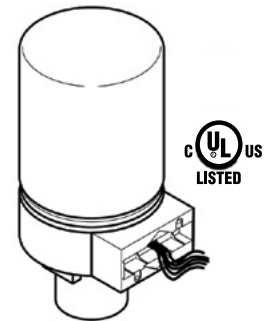

MP-52xx Proportional

Specifications

Inputs	
Compatible with	2 to 15 VDC from System 8000 controllers Operating Span: Approx. 3 VDC fixed. See F-26235-2 for valves. Impedance: 10,000 Ω or greater.
Power input	Refer to Model table.
Connections	Color-coded 4 ft. (1.2 m) leads.
Outputs	
Electrical	Auxiliary switch (Mx-52xx-500 models), 10 Amps, 120/240 Vac adjustable SPDT, factory set to close the N.C. contact at the retracted end of stroke.
Mechanical	Stroke, Valve: Approximately 9/16" (14.3 mm) over a nominal 6 VDC (fully retracted) to 9 VDC (fully extended).
Environment	
Temperature limits	Shipping & Storage, -40 to 140° F (-40 to 61° C) For valve actuators: Refer to the valve size and selection chart on page 95
Humidity	5 to 95% RH, non-condensing
Location	NEMA Type 1
Dimensions	6 3/4 x 3 1/4 Dia." (171 x 83 mm)
Regulatory compliance	RoHS and REACH

MP-52xx Hydraulic Proportional SR Actuators

Restrictions on the Maximum ambient temperature for valve actuator

Maximum ambient temperature (Check valve ratings)	Maximum ambient temperature of MP-541x or MPR-5x1x		Maximum ambient temperature of MA-521x or MP-521x	
	AV-600a or AV-7600b only for chilled water applications only	AV-600a or AV-7600b & AV-601	AV-600a or AV-7600b Only	AV-600a or AV-7600b & AV-601
366°F (180°C)	Do not use	88°F (31°C)	90°F (32°C)	90°F (32°C)
340°F (171°C)		93°F (34°C)	100°F (38°C)	100°F (38°C)
281°F (138°C)		103°F (39°C)	115°F (46°C)	140°F (60°C) ^c
181°F (83°C)		120°F (48°C)	140°F (60°C) ^c	
80°F (26°C)	140°F (60°C) ^c	140°F (60°C) ^c		

a - For detailed Linkage Installation instructions, refer to AV-600 Hydraulic Actuator Linkage Kit installation instructions, F-26279.

b - For detailed Linkage Installation instructions, refer to AV-7600 Hydraulic Actuator Linkage Kit installation instructions, F-26235.

c - Maximum allowable ambient temperature of the actuator.

Optional accessories

Linkages

AV-601	Linkage extension for hot water and steam applications; use with AV-7600.
AV-7600-1	Linkage for VB-7000.

Application

The AV-7600-1 Linkage kit is used to field assemble MA-521x, MP-521x, MP-541x and MP-561x round hydraulic actuators to ½” through 2” VB-7000 series valve bodies.

Features

- Provides direct-couple interface between MA, MP and MPR-5xxx actuators and valve bodies
- Fits all VB-7000 series valve bodies
- Includes spring choices for higher 2-Way valve close off

Specifications

- Actuator mounting: In any upright position above the center line of the valve body. For steam applications only, mount the actuator above the valve body at 45° from vertical.

AV-7600-1
Hydraulic Actuator
Linkage Kit

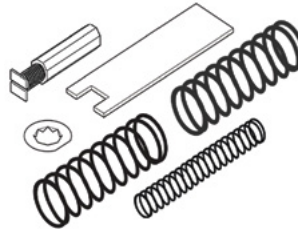

MP-541x Hydraulic Proportional SR Actuators

Application

These MP-54xx Series actuators provide electronic proportional control of valves requiring the return to normal position upon power interruption.

Features

- Proportional control by variable VDC input signal
- Compatibility with 2 to 15 VDC System 8000 input signals
- Spring return
- Fixed 3 VDC operating span
- Adjustable 2 to 12 VDC start point for paralleling or sequencing of actuators
- 10,000 Ω or greater input impedance
- 24 and 120 Vac models
- Damper models with linkage or base models that require separate damper or Linkage
- Die cast lower housing with ½" conduit opening and painted steel upper housing
- Hydraulic actuator with oil immersed motor, transducer, and pump

Model Table

Part number	Actuator power input				Positive positioner ^a	Timing in seconds @ 72° F (22° C)			Linkage	
	AC voltage +10% -15%	60 Hz		50 Hz		No Load Stroke		Retract on power loss		
		Watts	Amps	Watts		Amps	To Extend			To Retract
MP-5410	120	11.7	0.16	12.9	0.19	Yes	60	40	15	AV-600 AV-601b AV-7600-1
MP-5413	24	12.0	0.80	13.2	0.97					

a - Internal feedback circuitry provides positive positioning of valve stem in relation to Control signal.

b - May be required for steam or hot water.

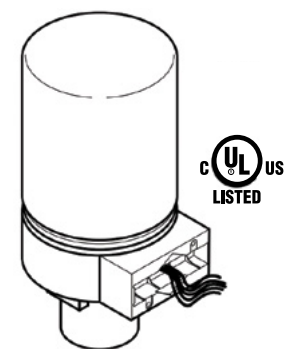

MP-541x Series Positive Positioning

Specifications

Inputs	Compatible with 2 to 15 VDC from System 8000 controllers
Operating span	Approx. 3 VDC fixed.
Start point	Adjustable 2 to 12 VDC. Factory set at 6 VDC. Impedance: 10,000 Ω or greater.
Connections	Color-coded 4 ft. (1.2 m) leads.
Outputs	
Electrical	Internal Power Supply: 20 VDC, 25 mA.
Mechanical	Stroke, Valve: Approximately 9/16" (14.3 mm) over a nominal 6 VDC (fully retracted) to 9 VDC (fully extended) input range.
Environment	
Ambient temperature limits	Operating: -20 to 140° F (-29 to 60° C) For valve actuators: Refer to the valve size and selection chart on page 95.
Humidity	5 to 95% RH, non-condensing
Location	NEMA Type 1
Dimensions	6¼ x 3¼ Dia." (171 x 83 mm)
Regulatory compliance	RoHS and REACH

MP-541x Hydraulic Proportional SR Actuators

Restrictions on the maximum ambient temperature for Valve Actuator

Maximum ambient temperature (Check Valve Ratings)	Maximum ambient temperature of MP-541x or MPR-5x1x		Maximum ambient temperature of MA-521x or MP-521x	
	AV-600a or AV-7600b Only for Chilled Water Applications Only	AV-600a or AV-7600b & AV-601	AV-600a or AV-7600b Only	AV-600a or AV-7600b & AV-601
366°F (180°C)	Do not use	88°F (31°C)	90°F (32°C)	
340°F (171°C)		93°F (34°C)	100°F (38°C)	
281°F (138°C)		103°F (39°C)	115°F (46°C)	140°F (60°C) ^c
181°F (83°C)		120°F (48°C)	140°F (60°C) ^c	
80°F (26°C)		140°F (60°C) ^c		

a - For detailed Linkage Installation instructions, refer to AV-600 Hydraulic Actuator Linkage Kit installation instructions, F-26279.
 b - For detailed Linkage Installation instructions, refer to AV-7600 Hydraulic Actuator Linkage Kit installation instructions, F-26235.
 c - Maximum allowable ambient temperature of the actuator.

Optional accessories

Linkages

AV-601	Linkage extension for hot water and steam applications; use with AV-7600.
AV-7600-1	Linkage for VB-7000.

Application

The AV-7600-1 Linkage kit is used to field assemble MA-521x, MP-521x, MP-541x and MP-561x round hydraulic actuators to ½" through 2" VB-7000 series valve bodies.

Features

- Provides direct-couple interface between MA, MP and MPR-5xxx actuators and valve bodies
- Fits all VB-7000 series valve bodies
- Includes spring choices for higher 2-Way valve close off

Specifications

- Actuator mounting: In any upright position above the center line of the valve body. For steam applications only, mount the actuator above the valve body at 45° from vertical.

AV-7600-1
Hydraulic Actuator
Linkage Kit

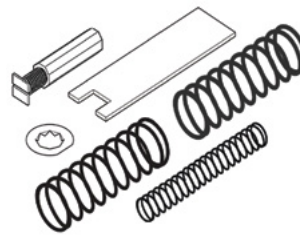

MPR-561x Hydraulic Proportional SR Actuators

Application

These MPR-561x Series actuators provide electronic proportional control of valves requiring return to normal position upon power interruption. They are compatible with controllers generating 4 to 20 mA input signals.

Features

- Spring return
- 24 and 120 Vac models available
- Die cast lower housing with ½" conduit opening and painted steel upper housing
- Hydraulic actuator with oil-immersed motor, transducer, and pump
- Proportional actuators controlled by a variable mAdc Input signal.
- 82.5 Ω input impedance
- Adjustable actuator startpoint

Model table

Part number	Actuator power input					Input signal	Timing in seconds @ 72° F (22° C) No load stroke		Linkage
	AC voltage ±10%	60 Hz		50 Hz			Extend	Retract	
		Watts	Amps	Watts	Amps				
MPR-5610	120	11.7	0.16	12.9	0.19	4 to 20 mA	60	30	AV-600 AV-601*
MPR-5613	24	12.0	0.80	13.2	0.97				

a - May be required for steam or hot water.

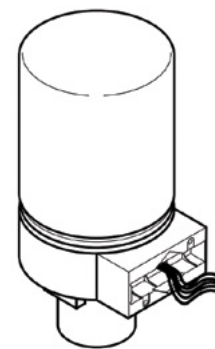

MPR-561x Series Proportional

Specifications

Inputs	
Control circuit	MPR-561x Series: Two-wire.
Input impedance	82.5 Ω for 4 to 20 mA input.
Power input	Refer to Model table
Connections	Color-coded 4 ft. (1.2 m) leads.
Outputs	
Electrical	Position signals: Internal feedback circuitry provides positive positioning of the valve in relation to the controller signal. Startpoint adjustment: Adjustable potentiometer provides manual adjustment of the actuator startpoint.
Mechanical	Stroke, valve: Approximately 9/16" (14.3 mm) from fully retracted to fully extended. Proportional output torque rating of 15 lb-in (1.7 N-m), available throughout the entire stroke, based on the lowest force available under normal operation, the spring return stroke, or at a minimum (-10%) supply voltage.
Environment	
Temperature limits	Shipping and storage: -40 to 140° F (-40 to 60° C) Operating: -20 to 140° F (-29 to 60° C) Operating, valve: Refer to the valve size and selection chart on page 95
Humidity	5 to 95% RH, non-condensing
Location	NEMA Type 1
Dimensions	MP-5x1x: 6¼ x 3¼" (171 x 83 mm)
Regulatory compliance	RoHS and REACH

MPR-561x Hydraulic Proportional SR Actuators

Optional Accessories

Linkages

AV-601	Linkage extension for hot water and steam applications; use with AV-7600.
AV-7600-1	Linkage for VB-7000.



Application

The AM-708 500 ohm resistor converts a 4 to 20 mA signal to a 2 to 10 VDC signal.

Specifications

- Actuators: MS40-7043, MS41-7073, MS41-7153, MS40-717x, MS41-6083, MS41-6153 and MS41-6343.
- Wire leads.



Application

The AV-7600-1 Linkage kit is used to field assemble MA-521x, MP-521x, MP-541x and MP-561x round hydraulic actuators to ½" through 2" VB-7000 series valve bodies.

Features

- Provides direct-couple interface between MA, MP and MPR-5xxx actuators and valve bodies
- Fits all VB-7000 series valve bodies
- Includes spring choices for higher 2-Way valve close off

Specifications

- Actuator mounting: In any upright position above the center line of the valve body. For steam applications only, mount the actuator above the valve body at 45° from vertical.

AV-7600-1
Hydraulic Actuator
Linkage Kit

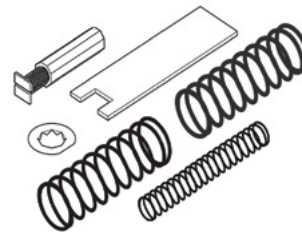

AV-601 Extension for MA, MP 5x1x-xxx, MPR-5x1x, MP-541x

Application

The AV-601 linkage extension kit is used to increase the allowable ambient temperature range of MA, MP-5x1x-xxx, MPR-5x1x and MP-541x Series actuators. The MP-541x and MPR-5x1x Series of actuators require the AV-601 extension. This kit provides thermal insulation between the valve and the actuator. It does not insulate the actuator from radiant or convective heat transfer.

Specifications

- Kit consists of an extension coupling and a spacer.
- Dimensions: Add 2-1/32" (52 mm) to the "E" dimension for the valve assembly using an AV-601 linkage extension. Refer to complete dimensions in the separately available Wiring, Dimensions and Reference document F-28125 from the mySchneider download center.
- 2-Way Valves, Union End
- 2-Way Valves, Threaded
- 3-Way and Sequencing Valves, Flared
- 3-Way and Diverting Valves, Threaded

Restrictions on the maximum ambient temperature for Valve Actuator

Maximum ambient temperature (check valve ratings)	Maximum ambient temperature of MP-541x or MPR-5x1x		Maximum ambient temperature of MA-521x or MP-521x	
	AV-600a or AV-7600b only for chilled water applications only	AV-600a or AV-7600b & AV-601	AV-600a or AV- 7600b Only	AV-600a or AV-7600b & AV-601
366°F (180°C)	Do not use	88°F (31°C)	90°F (32°C)	
340°F (171°C)		93°F (34°C)	100°F (38°C)	
281°F (138°C)		103°F (39°C)	115°F (46°C)	140°F (60°C) ^c
181°F (83°C)		120°F (48°C)	140°F (60°C) ^c	
80°F (26°C)		140°F (60°C) ^c		

a - For detailed Linkage Installation instructions, refer to AV-600 Hydraulic Actuator Linkage Kit installation instructions, F-26279.

b - For detailed Linkage Installation instructions, refer to AV-7600 Hydraulic Actuator Linkage Kit installation instructions, F-26235.

c - Maximum allowable ambient temperature of the actuator.

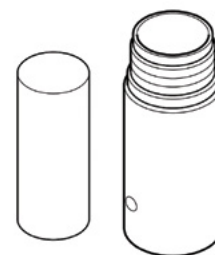

AV-601 Linkage Extension for Electric/Electronic Hydraulic Valve Actuators

MK-2690 Pneumatic Valve Actuator - Proportional

Application

The MK-2690 provides proportional pneumatic control of ½" to 2" VB-7000 Series valves (subject to close-off ratings) and discontinued ½" to 1¼" VB-9xxx valves.

Features

- Compact size with 6 in² (39 cm²) effective area
- Rugged die cast aluminum housing
- Replaceable beaded, molded, neoprene diaphragm

Model table

Model number	Nominal spring range ^a (spring color Code)	
	psig	kPa
MK-2690	3 to 7 (Yellow)	21 to 48
	5 to 10 (Black)	34 to 69
	8 to 13 (Blue)	55 to 90

a - Nominal (no load) condition, spring ranges based on ½" (13 mm) maximum stroke, provided by AV-7400 linkage (order separately).

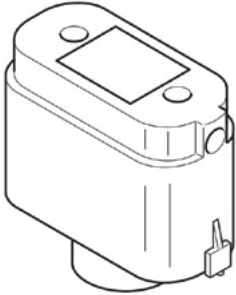

MK-2690 Proportional Pneumatic Valve Actuator

Specifications

Inputs	Compatible with proportional pneumatic signal. Refer to Model table.
Start point	Non-adjustable.
Air connections	1/8" FNPT located on side of housing.
Max. air pressure	30 psig (207 kPa)
Mechanical outputs	
Stroke	5/8" available
Environment	
Ambient temperature limits	Shipping: -40 to 220° F (-40 to 104° C) Operating: -20 to 220° F (-29 to 104° C)
Humidity	5 to 95% RH, non-condensing
Spring	(see Optional accessories below)
Dimensions	3-9/16" H x 5" W x 2¼" D (90 x 127 x 57 mm)

Optional accessories

Spring	Stainless steel spring retracts actuator shaft and raises valve stem on loss of air pressure. Springs provided in AV-400 or AV-7400 linkage.
Linkages	
AK-42309-500	Positive Positioner & linkage; use with MK-2690-0-0 to 1 or MK-2690-0-0-2 models only.
AV-400	Linkage (includes parts for VB-7000 and VB-9xxx valves and 3 to 7, 5 to 10, & 8 to 13 springs)
AV-7400	Linkage for VB-7000 valves only. (includes 3 to 7, 5 to 10, & 8 to 13 springs.)
TOOLS (factory available)	
TOOL-095-1	Pneumatic calibration tool kit.

Maintenance parts

PNV-144-43	3 to 7 psig spring
PNV-145-45	5 to 10 psig spring
PNV-145-48	8 to 13 psig spring
PNV-102-1	Diaphragm

AV-7400 Pneumatic Actuator Linkage Kit

Application

The AV-7400 Linkage Kit is used to field install MK-2690 pneumatic actuators to a variety of ½” to 2” VB-7000 series valve bodies.

Features

- Springs are provided for control-signal applications, including 3 to 7, 5 to 10 and 8 to 12 psig.
- Kit fits all VB-7000 series valve bodies.
- Blue spring used with AV-7600-1 supports hydraulic 4 to 20 mA and 0 to 10 VDC applications.

Specifications

- Actuator mounting: In any upright position with actuator above the center line of the valve body.

Spring specifications

Spring range psig (kPa)	Spring color
3 to 7 (21 to 48)	Yellow
5 to 10 (34 to 68)	Black
8 to 13 (55 to 89)	Blue

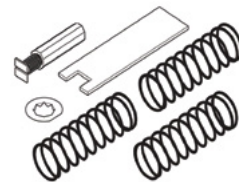

AV-7400
Pneumatic Actuator
Linkage Kit

MK-46xx Pneumatic Actuator - Proportional

Application

The MK-46xx Series and MK-4621-422 proportional pneumatic actuators, with 11 sq. in. (71 cm²) effective diaphragm area, are used to control ½" to 2" VB-7000 series valves.

Features

- Rugged die cast aluminum construction
- Rolling diaphragm
- Multiple spring ranges for various applications
- Adjustable start point (refer to Specifications)
- ½" Nominal stroke
- Can also be used on ½" stroke discontinued VB-9xxx series valves (½" to 1¼").

Model table

Model number	Nominal spring range ^a	
	psig	kPa
MK-4601	3 to 6	21 to 41
MK-4611	5 to 10	34 to 69
MK-4621	10 to 13	69 to 90
MK-4621-422	10 to 11.25	69 to 77
MK-4641	3 to 13	21 to 90

a - Nominal (no load) condition, spring ranges based on ½" (13 mm) maximum stroke.

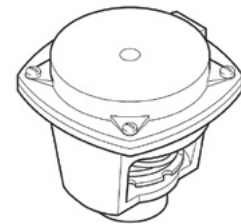

MK-46xx
Proportional Pneumatic Valve
Actuator

Specifications

Construction	Compatible with proportional pneumatic signal. Refer to Model table.
Housing	Die cast aluminum.
Diaphragm	Replaceable, beaded, molded, neoprene (Part number PNV-002).
Stroke	½" (12.7 mm) nominal.
Spring	Retracts actuator shaft and raises valve stem on loss of air pressure.
Nominal spring range	Refer to Model table.
Starting point	Field adjustable.
MK-4601, MK-4621	+½ psig (7 to 14 kPa).
MK-4611, MK-4641	±2 psig (14 kPa).
Air connections	1/8" FNPT.
Max. air pressure	30 psig (207 kPa).
Environment	
Ambient temperature limits	Shipping: -40 to 220° F (-40 to 104° C) Operating: -20 to 220° F (-29 to 104° C)
Mounting	In any upright position with actuator head above the center line of the valve body.
Dimensions	3-7/8 x 4¾ x 4¾" (99 x 121 x 121 mm)
Maintenance parts	See F-26033

Optional accessories

Linkage	AV-401. See F-19072
Positive Positioner & linkage	e; AK-42309-500 use with MK-46x1-0-2.
Tools (factory available)	TOOL-095-1 Pneumatic calibration tool kit.

MK-66xx Pneumatic Actuator - Proportional

Application

MK-66xx proportional pneumatic actuators, with 50 sq. in. (323 cm²) effective diaphragm area, are used to control 1½" to 2" VB-7000 series valves.

Features

- Rugged die cast aluminum construction
- Rolling diaphragm
- Three spring ranges for various applications
- Start point adjustable ±2 psi

Model table

Model number	Nominal spring range		Nominal stroke in. (mm)
	psig	kPa	
MK-6601	3 to 8	21 to 55	½ (13.7)
MK-6611	5 to 10	34 to 69	
MK-6621	8 to 13	55 to 90	

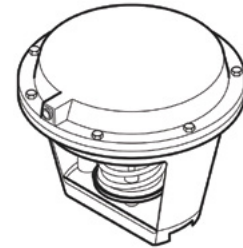

MK-66xx

Proportional Pneumatic Valve Actuator

Specifications

Construction	
Housing	Die cast aluminum
Diaphragm	Replaceable beaded molded neoprene (Part number PNV-202)
Stroke	Refer to Model table.
Spring	Retracts actuator shaft and raises valve stem on loss of air pressure
Nominal spring range	Refer to Model table.
Starting point	Adjustable ±2 psig (±14 kPa)
Maximum air pressure	30 psig (207 kPa)
Ambient temperature limits	
Shipping	-40 to 220°F (-40 to 104°C)
Operating	-20 to 220°F (-29 to 104°C)
Air connections	1/8" FNPT
Mounting	Any upright position with actuator head above center line of the valve body
Dimensions	7¾" H x 10½" W x 10½" D (199 x 267 x 267 mm)
Maintenance parts	See F-26033
Optional accessories	
Linkage	AV-430 (See F-19072).

AK-42309-500 Positive Positioning Relay

Application

Positive Positioner Pneumatic Relay is used to accurately position an actuator stroke with respect to signal pressure from the controller. It can also be used to change the effective spring range of an actuator and increase the capacity of a controller.

Features

For accurate positioning of valve and Damper Actuators, this positioner utilizes a pilot-operated, relay-type position-sensing mechanism, much more sensitive to actuator position changes than some competitive "force-balance" positioners.

Model Number	Description
AK-42309-500	Positive Positioning Relay with Mounting Linkage.

Note: This model cannot be used with M556, M572, M573, M574 Series actuators. Use N800-0555 positioner with M556, M573, and M574.

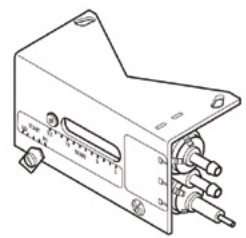

AK-42309-500
Positive Positioning Relay

Specifications	
Action	Direct (increase in output pressure to actuator with an increase in pilot pressure from controller)
Pilot input	0 to main air pressure, psig.
Output	0 to main air pressure, psig.
Construction	
Housing	Polysulfone
Diaphragm	Neoprene
Start point	Adjustable 1 to 12 psig (7 to 83 kPa)
Span	Adjustable 2 to 13 psi (14 to 90 kPa); factory set at 5 psig.
Stroke	Adjustable 2 to 13 psi (14 to 90 kPa); factory set at 5 psig with feedback spring for 7/16 to 5" stroke.
Supply air pressure	Clean, oil free, dry air required (refer to EN-123).
Maximum	30 psig (207 kPa).
Nominal supply	15 to 20 psig (103 to 138 kPa)
Environment	
Ambient temperature limits	Shipping: -40 to 160°F (-40 to 71°C). Operating: 32 to 140°F (0 to 60°C).
Humidity	5 to 95% R.H., non-condensing.
Locations	NEMA Type 1 (IP10).
Air connection code	Refer to Figure 1
Air connections	
"M" and "B"	Barbed for 1/4" O.D. plastic tubing
"P"	Dual-contoured for 1/4" O.D. and 5/32" O.D. tubing
Air consumption for sizing air compressor	19 scim (5.2 mL/s) at 20 psig (138 kPa) supply
Air capacity for sizing air mains	20 scim (5.5 mL/s).
Flow capacity	860 scim (235 mL/s) at 20 psig (138 kPa) supply
Mounting linkage	All necessary linkage provided to assemble AK-42309-500 to MK-2690 actuator and the following actuator series; MK-3000, MK-4400, MK-4600, MK-4700, MK-4800, MK-6600, MK-6800, MK-6900, MK-7100, MK-8800 and MK-8900.
Dimensions	2½ H x 4½ W x 3 D" (64 x 114 x 76 mm).
Regulatory compliance	RoHS and REACH

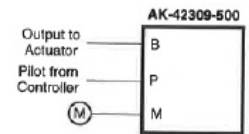

Figure 1 Piping Connections.

More information:
Scan the QR code or visit the link below for more information.



Visit:

<http://goo.gl/LJCLEb>

Ordering VB-8/9000 Valves

Specify two part number fields (2 and 6 below) to determine the valve part number.

<p>1) Control Signal</p> <p>V B</p>	<p>2) Trim and Valve Configuration</p> <p>— </p>	<p>3) Pipe End Connections</p> <p>3 —</p> <p>Specify Option 3 (Flanged) for all valves.</p>	<p>4) Actuator or Linkage</p> <p>0 —</p>	<p>5) Pattern Code</p> <p>5 —</p> <p>Specify Option 5 (Flanged) for all valves.</p>	<p>6) Port Code Cv Value</p> <p> </p> <p>For water, steam, glycol and similar non flammable, non toxic fluids, choose based on the Capacity Sizing section of this catalog. Below 2½", go to the valve size and selection chart on page 95.</p>
--	---	--	---	--	--

Refer to the guide below.

Ordering VB-8000, VB-9000 Valves

<p>V B</p> <p>B = Valve Body</p>	<p>— </p> <p>Trim and Configuration</p> <p>821 = 2-Way, Stem Up Open, Brass Trim EPDM Seat</p> <p>822 = 2-Way, Stem Up Closed, Brass Trim EPDM Seat</p> <p>830 = 3-Way, Mixing or Diverting, Brass Trim (Bottom port is "Common")</p> <p>931 = 3-Way, Mixing, Brass Trim, Metal-to-Metal (One end port is "Common")</p>	<p>3</p> <p>Pipe Connection End Fitting</p> <p>3 = Flanged</p>	<p>— 0 —</p> <p>Actuator or Linkage Code</p> <p>0 = No actuator, valve body (VB) only.</p>	<p>— 5 —</p> <p>Connection</p> <p>5 = Flanged</p>	<p>— </p> <p>Port Code</p> <p>2½" to 6" (Cv 56 to 500)</p> <p>12 = 2½"</p> <p>13 = 3"</p> <p>14 = 4"</p> <p>15 = 5"</p> <p>16 = 6"</p>
--	---	--	--	---	---

NOTE: Threaded bodies are not available in size 2½" and larger.

VB-8000 2½” to 6” 2 and 3-Way Valves

VB-8213, VB-8223, & VB-8303 Valve Bodies

Ports		2-Way Flanged		3-Way Flanged	
Application		Chilled or hot water, steam ⁱ		Chilled or hot water ⁱ	
Size		2½” to 6”			
Valve body part number		VB-8213-0-5-P	VB-8223-0-5-P	VB-8303-0-5-P	
Valve body action		2-way stem open	2-way stem up closed	3-way/diverting ^a	
Material	Flow type	Equal %		Modifier linear	
	Body	Cast iron			
	Seat	Forged brass			
	Stem	Stainless steel			
	Plug	Forged brass			
	Packing	Spring loaded TFE/EPDM			
	Seat ring	EPDM		None	
ANSI pressure class, psig		125 (up to 200 psig below 150°F)			
Maximum inlet pressure steam psig (kPa)		35 psig (241 kPa)		-	
Allowable control media temperature °F (°C) ^b		20°F to 281°F (-7°C to 138°C)			
Close-off pressure, psi (kPa)		125 psi (856 kPa) ^c		35 psi (241 kPa) ^c	
P code	Valve size, in.	Cv (kvs)		Cv (kvs) mixing ^d	Cv (kvs) diverting ^e
12	2½	56 (48)	56 (48)	80 (69)	95 (82) ^f
					115 (99) ^g
13	3	85 (74)	85 (74)	110 (95)	120 (104) ^h
					190 (164) ^h
14	4	145 (125)	145 (125)	190 (164)	290 (251) ^h
					290 (251) ^h
15	5	240 (208)	240 (208)	290 (251)	500 (433) ^h
					500 (433) ^h
16	6	370 (320)	370 (320)	500 (433)	500 (433) ^h
					500 (433) ^h

a - VB-8303 valves may be used as mixing or diverting valves. VB-8303 valves will also operate sufficiently as 2-Way angle valves if either end (side) port is closed off.

b - Freeze protection required for temperatures below 32°F (0 °C). Avoid ice formation on stems.

c - Valve port in closed position. See Specifications in following pages for maximum allowable VB-8xxx differential pressure for valve in any open position.

d - Mixing configuration, ports A and B are inlets, port AB is outlet (located on bottom).

e - Diverting configuration, port AB is inlet, ports A and B are outlets. Port AB located on bottom.

f - Diverting configuration, flow AB to A ports.

g - Diverting configuration, flow AB to B ports.

h - All Diverting flow configurations, flow AB to either A or B ports.

i - Glycol up to 50%

VB-8000 3-Way Flow Patterns

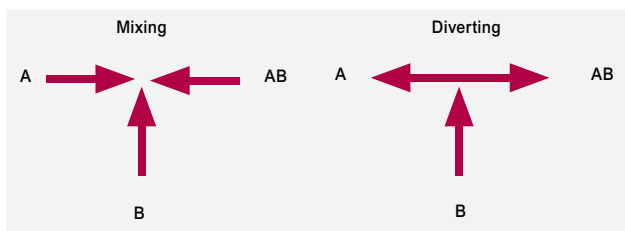

2-Way and 3-Way Valves
2-Way Stem Up Open or Stem Up Closed
3-Way/Diverting
ASA 125 Flanged Cast Iron Body

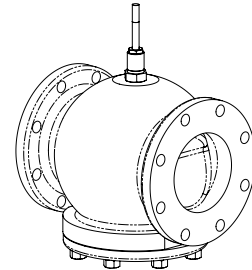

VB-8213

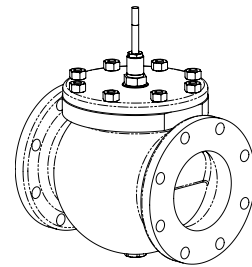

VB-8223

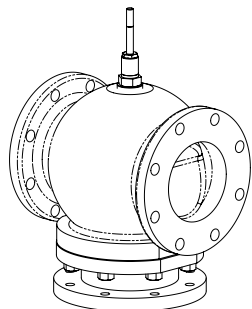

VB-8303

VB-9313 2½” to 6” 3-Way Valves

Application

VB-9313 Series 3-Way Valves control hot or chilled water in heating or air conditioning systems. These valves must be piped with two inlets (“A” and “B” ports) and one outlet (“AB” port). They are used for two-position or proportional control applications. Valve assemblies require an actuator and a linkage that may be factory or field assembled.

Features

- Valve sizes 2½” to 6”
- 125 psig pressure rating per ANSI Standards (B16.1–1993) for flanged cast iron bodies
- Spring-loaded TFE & EPDM packing

Specifications		Valve Body Series VB-9313-0-5-P		
Application		Chilled or hot water °		
Flow characteristics		Mixing		
Sizes		2½” to 6”		
Type of end fitting		125 lb. Flanged		
Valve materials	Body	Cast Iron		
	Seat	Bronze		
	Stem	Stainless steel		
	Plug	Brass		
	Packing	Spring loaded TFE & EPDM		
	Disc	None		
ANSI pressure class, psig		125 (up to 200 psig below 150°F)		
Allowable control media temperature, °F (°C)		40°F to 300°F (4°C to 149°C)		
Allowable differential pressure, water, psi (kPa) ^a		35 psi (241 kPa) max. for normal life		
Valve size, In.	Cv ^b Rating	kvs ^b Rating	Stroke	Complete valve body part number
2½	74	64	7/8" (22 mm)	VB-9313-0-5-12
3	90	78	7/8" (22 mm)	VB-9313-0-5-13
4	170	147	7/8" (22 mm)	VB-9313-0-5-14
5	290	251	1¼" (45 mm)	VB-9313-0-5-15
6	390	337	1¼" (45 mm)	VB-9313-0-5-16

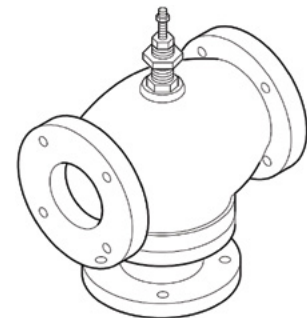

VB-9313-0-5-P
(Typical)

a - Maximum recommended differential pressure in open position. Do not exceed the recommended differential pressure (pressure drop) or integrity of parts may be affected.

Exceeding maximum recommended differential pressure voids the product warranty.

b - $kvs = m^3/h (\Delta P = 100 \text{ kPa})$ $kvs = Cv / 1.156$ $Cv = gpm / \sqrt{\Delta P}$ (in psi).

c - Glycol up to 50%

VB-93xx 3-Way Flow Pattern

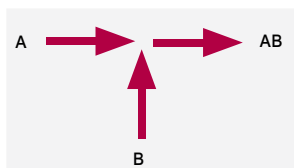

3-Way Valve Sizing for Water

Sizing for water

Two-position

Two-position control valves are normally selected by "line size" to keep pressure drop at a minimum. If it is desirable to reduce the valve below line size, then 10% of available pressure (that is, the pump pressure differential available between supply and return mains with design flow at the valve location) is normally used to select the valve.

Proportional and floating

Proportional and floating control valves are usually selected to take a pressure drop equal to at least 50% of the available pressure. As available pressure is often difficult to calculate, the normal procedure is to select the valve using a pressure drop at least equal to the drop in the coil or other load being controlled (except where small booster pumps are used) with a minimum recommended pressure drop of 5 psi (34 kPa). When the design temperature drop is less than 60°F (33°C) for conventional heating systems, higher pressure drops across the valve are needed for good results.

Conventional heating system pressure drops

Design temperature load drop °F (°C)	Recommended pressure drop (% of available pressure)	Multiplier on load drop
60 (33) or more	50%	1x load drop
40 (22)	66%	2x load drop
20 (11)	75%	3x load drop

Reducer affects

On full flow bodies, offset the affects of directly connected reducer(s) by choosing flow coefficients 6% or more higher.

Cv (flow coefficient) determination

The valves' water capacity is based on the following formula:

$$C_v = \frac{\text{GPM}}{\sqrt{\Delta P}} \text{ or } C_v = \text{GPM} \sqrt{\frac{\text{Specific Gravity}}{\Delta P}}$$

Where:

Cv = Coefficient of flow

Cv is defined as the flow in GPM with ΔP = 1 psi with the valve completely open

GPM = U.S. gallons per minute (60°F, 15.6°C)

ΔP = Differential pressure in psi (pressure drop)

Proportional 3-Way valves

Recommended pressure drop.

Bypass application

50% of available pressure, or equal to pressure drop through the load at full flow. 3-Way valves in the return used to control output by throttling water flow to the load (bypass applications) are controlling output in the same manner as throttling 2-Way valves, and must be selected using the same high pressure drops if good control results are to be obtained.

Constant flow applications

20% of available pressure, or equal to 1/4 of the pressure drop through the load at full flow. 3-way valves used with individual pumps to control output by varying water temperature to the load (constant flow applications) are controlling output by mixing two water sources at different temperatures and do not require high pressure drops for good control results.

Water capacity graph instructions

To select the appropriate valve Cv from the graph:

1. Select the required flow from the "Flow in GPM" axis.
2. Select available pressure drop from the "Pressure Drop in psi" axis.
3. Select the appropriate line and follow to the Capacity Cv (Kv) listing and choose the closest valve Cv flow coefficient.
4. Confirm the selection by calculation from the water equations.

Additional Water Valve Sizing Information

For more information, download these documents from our website.

- CA-27 3-Way Valves Application Information
- Valve Selection Table Water, F-11080

VB-8xx3 Valve Body Characteristics

System design considerations

Note: The information in this section describes characteristics of the VB-8xx3 valve bodies, which are used in the Vx-8xx3 valve assemblies. Control precision

2-Way valves:

The flow curve shown below is representative of all sizes. All valve plugs have lower gain when nearly closed to enhance control at low demand. 2-way valves are nominally equal percentage and normally used for water and low pressure steam.

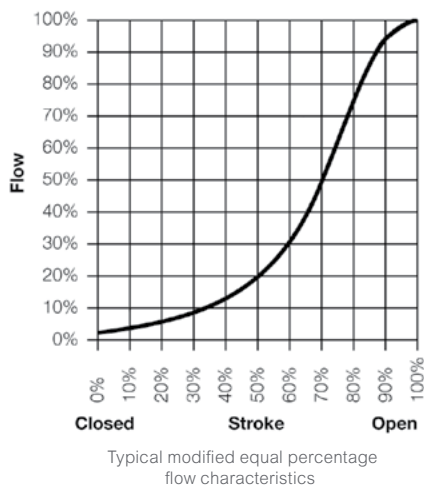

Temperature/pressure ratings

Temperature and pressure ratings of 2-way and 3-way valves are shown below. Ratings conform with published values and disclaimer.

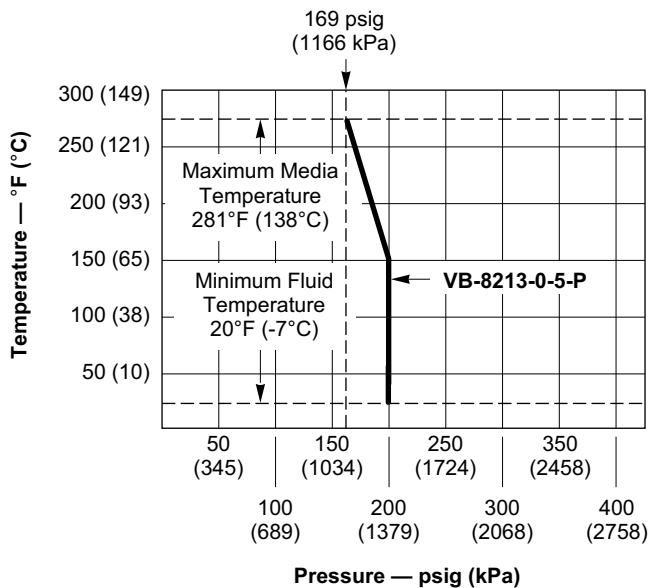

3-Way valves:

3-way valves are designed so that the flow from either of the inlet ports to the outlet is nominally linear, which means the total flow from the outlet is almost constant over the stroke of the valve stem. The flow is limited at the initial opening similar to an equal percentage curve to enhance system stability. Typical flow characteristics of the VB-8303 series valve bodies are shown below.

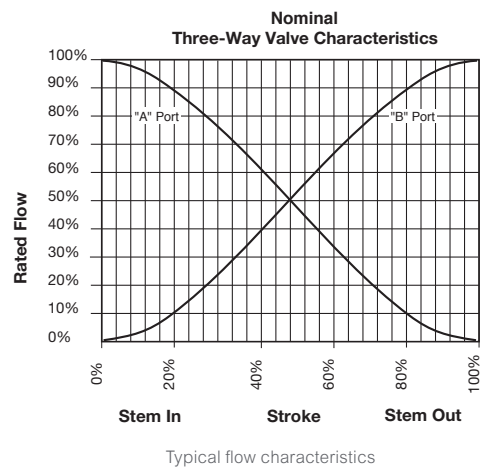

Rangeability

Rangeability is the ratio of rated flow to the minimum controllable flow through a valve. The nominal rangeability of the VB-8xx3 Series is greater than 100:1.

VB-8xx3-0-5-P (Cast Iron Body with Flanged End Fittings)

Standards: Pressure to ANSI B16.1, Class 125, with 200 psi (1379 kPa) up to 150 °F (65 °C), decreasing to 169 psi (1165 kPa) at 281°F (138 °C)

Materials: Valve body: Cast iron, ASTM A126 Class B

Trim: Stainless steel stem, forged brass plug, metal-to-metal or EPDM seat ring with TFE/EPDM packing parts and silicone packing grease.

Close-off ratings

Nominal actuator close-off ratings are based on ANSI IV (0.01% leakage) for valves with EPDM seat rings such as VB-8213 and VB-8223.

Metal-to-metal trim valves such as VB-8303 are designed for ANSI III (0.1% leakage).

VB-82x3 Water Flow Coefficient and Capacity

Water flow coefficient (Cv)

Sizing a valve requires selecting a flow coefficient (Cv), which is defined as the flow rate in gallons per minute (gpm) of 60°F water that will pass through the fully open valve with a 1 psi pressure drop (ΔP). It is calculated according to the formulas shown in Cv Equation for Water and Cv Equation for Steam.

Since the flow rate through the heat exchanger is usually specified, the only variable normally available in sizing a valve is the pressure drop. The following information can be used to determine what pressure drop to use in calculating a valve Cv. Using the calculated Cv, consult the water capacity table on this page or steam capacity to select the valve body with the nearest available Cv.

Caution: Be sure that the anticipated pressure drop across the valve will not exceed the close-off pressure rating and the maximum pressure differential rating listed in the Vx-8xxx Selection Guide, F-27199.

Two-position

Two-position control valves are normally selected by "line size" to keep pressure drop at a minimum. If it is desirable to reduce the valve below line size, then 10% of available pressure (that is, the pump pressure differential available between supply and return mains with design flow at the valve location) is normally used to select the valve.

Proportional

Proportional control valves are usually selected to take a pressure drop equal to at least 50% of the available pressure. As available pressure is often difficult to calculate, the normal procedure is to select the valve using a pressure drop at least equal to the drop in the coil or other load being controlled (except where small booster pumps are used) with a minimum recommended pressure drop of 5 psi (34 kPa). When the design temperature drop is less than 60°F (33°C) for conventional heating systems, higher pressure drops across the valve are needed for good results (see the conventional heating system table below).

Conventional heating system pressure drops

Design temperature load drop °F (°C)	Recommended pressure drop (% of available pressure)	Multiplier on load drop
60 (33) or More	50%	1 x load drop
40 (22)	66%	2 x load drop
20 (11)	75%	3 x load drop

Secondary circuits with small booster pumps: 50% of available pressure difference (equal to the drop through load, or 50% of booster pump head).

Water Table

Water capacity in gallons per minute for VB-82x3 Series

Valve body part number	Cv Rating	Differential pressure (DP in psi)														
		1	2	3	4	5	6	7	8	9	10	15	20	25	30	35
VB-82x3-0-5-12	56	56	79	97	112	125	137	148	158	168	177	217	250	280	307	331
VB-82x3-0-5-13	85	85	120	147	170	190	208	225	240	255	269	329	380	425	466	503
VB-82x3-0-5-14	145	145	205	251	290	324	355	384	410	435	459	562	648	725	794	858
VB-82x3-0-5-15	240	240	339	416	480	537	588	635	679	720	759	930	1073	1200	1315	1420
VB-82x3-0-5-16	370	370	523	641	740	827	906	979	1047	1110	1170	1433	1655	1850	2027	2189

Cv equation for water

Where:

$$Cv = \frac{GPM}{\sqrt{\Delta P}} \quad \Delta P = \left(\frac{GPM}{Cv}\right)^2 \quad GPM = Cv\sqrt{\Delta P}$$

Cv = Coefficient of flow

gpm = Flow rate of water that will pass through fully open valve, measured in U.S. gallons per minute (60 °F (15.6 °C) water)

DP = Differential pressure (pressure drop), measured in psi

VB-82x3 Steam Capacity and Vapor Pressures

Steam

Two-position

Two-position zone valves and direct radiation valves are normally sized using a minimum of 10% of inlet pressure (psig).

Proportional

Proportional control valves are normally sized as follows:

For low pressure (15 psig or less), use ΔP of 80% of gauge inlet pressure.

For steam pressures greater than 15 psig, use ΔP of 42% of absolute (gauge plus 14.7) inlet pressure.

When the Cv required is between two valve sizes, select the larger size. Do not size steam valves using a pressure drop greater than 42% of the absolute inlet pressure.

Steam Table

Steam capacity in pounds per hour for VB-82x3 Series

Valve body part number	Cv rating	Differential pressure (DP in psi) ^a															
		2 psig inlet		5 psig inlet		10 psig inlet		15 psig inlet		20 psig inlet		25 psig inlet		30 psig inlet		35 psig inlet	
		0.2	1.6	0.5	4	1	8	1.5	12	2	14	2.5	16	3	18	3.5	20
VB-82x3-0-5-12	56	305	826	520	1331	818	1942	1093	2448	1359	2860	1620	3271	1879	3683	2136	4094
VB-82x3-0-5-13	85	463	1253	790	2021	1241	2947	1658	3716	2062	4341	2459	4965	2852	5590	3242	6214
VB-82x3-0-5-14	145	790	2138	1348	3447	2118	5027	2829	6339	3518	7405	4195	8470	4865	9536	5531	10601
VB-82x3-0-5-15	240	1308	3539	2231	5706	3505	8322	4683	10493	5823	12257	6943	14021	8053	15784	9156	17548
VB-82x3-0-5-16	370	2016	5456	3439	8796	5404	12830	7219	16177	8977	18896	10704	21615	12415	24334	14115	27053

^a - Left column shows # per hour with a 10 % pressure drop and right column shows # per hour with an 80% pressure drop.

Cv equation for steam

$$Cv = \frac{Q \times K}{3\sqrt{\Delta P \times P2}} \quad Q = \frac{3Cv\sqrt{\Delta P \times P2}}{K}$$

Where:

Cv = Coefficient of flow.

Q = Flow rate of steam that will pass through fully open valve, measured as pounds per hour of steam.

ΔP = Differential pressure (pressure drop), measured in PSI.

P2 = Outlet pressure, measured in psia (absolute pressure). P2 = Inlet pressure + 14.7 – ΔP

K = 1 + (0.0007 x °F superheat). K = 1 for saturated steam.

VB-82x3 Steam Capacity and Vapor Pressures

Cavitation limitations on valve pressure drop

A valve selected with too high a pressure drop can cause erosion of discs and/or wire drawing of the seat. In addition, cavitation can cause noise, damage to the valve trim (and possibly the body), and choke the flow through the valve.

Do not exceed the maximum differential pressure (pressure drop) for the valve selected.

The following formula can be used on higher-temperature water systems, where cavitation could be a problem, to estimate the maximum allowable pressure drop across the valve:

$$P_m = 0.5 (P_1 - P_v)$$

Where

P_m = Maximum allowable pressure drop

P_1 = Absolute inlet pressure (psia)

P_v = Absolute vapor pressure (psia)

Note: Add 14.7 psi to the gauge supply pressure to obtain the absolute pressure value.

For example, if a valve is controlling 200°F water at an inlet pressure of 18 psig, the maximum pressure drop allowable would be:

$$P_m = 0.5 [(18 + 14.7) - 11.53] = 10.6 \text{ psi (Vapor pressure of 200°F water is 11.53 psi.)}$$

Therefore, if the pressure drop for this valve is less than 10.6 psi, cavitation should not be a problem.

Systems where cavitation is shown to be a problem can sometimes be redesigned to provide lower inlet velocities. Valves having harder seat materials should be furnished if inlet velocities cannot be lowered.

For additional valve sizing information, see the Vx-8xxx Selection Guide, F-27199.

Vapor pressure of water table

Water temp. (°F)	Vapor pressure (psia)	Water temp. (°F)	Vapor pressure (psia)	Water temp. (°F)	Vapor pressure (psia)	Water temp. (°F)	Vapor pressure (psia)
40	0.12	90	0.70	140	2.89	190	9.34
50	0.18	100	0.95	150	3.72	200	11.53
60	0.26	110	1.28	160	4.74	210	14.12
70	0.36	120	1.69	170	5.99	220	17.19
80	0.51	130	2.22	180	7.51	230	20.78

VB-9313 Valve Body Characteristics

Flow characteristics

3-way valves are designed so that the flow from either of the inlet ports to the outlet is approximately linear, which means the total flow from the outlet is almost constant over the stroke of the valve stem. Typical flow characteristics of VB-9313 series valve bodies are shown below.

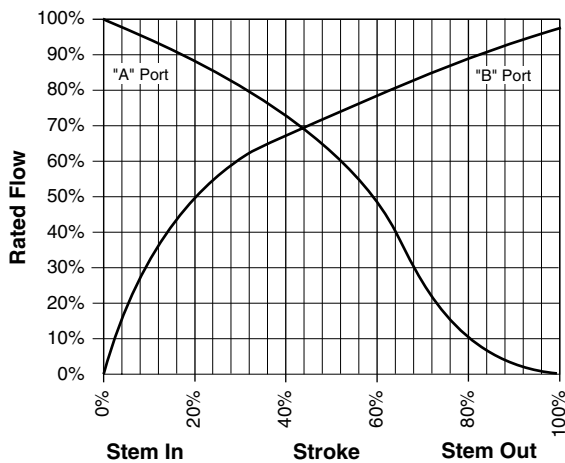

Typical flow characteristics

Temperature / pressure ratings

VB-9313-0-5-P (Flanged Cast Iron Body)

Standards: ANSI B16.1-1993

Materials: ASTM A126 Class B

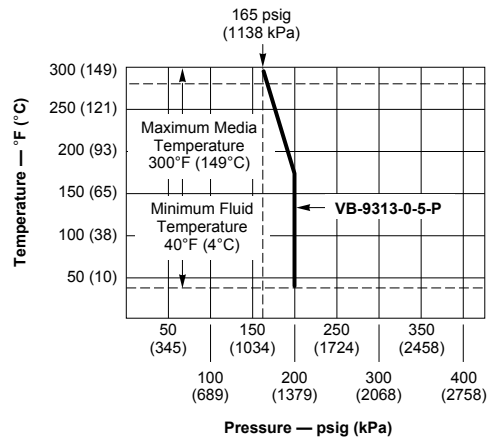

Temperature and Pressure Ratings for VB-9313 Series Valve Bodies

Rangeability

Rangeability is the ratio of rated flow to the minimum controllable flow through a valve. For mixing valves, control begins as soon as plug displacement allows flow. Thus, 3-way valve rangeability normally exceeds 500:1, which is the reciprocal of 0.2% nominal leakage.

Water

Two-position

Two-position control valves are normally selected "line size" to keep pressure drop at a minimum. If it is desirable to reduce the valve below line size, then 10% of available pressure (that is, the pump pressure differential available between supply and return mains with design flow at the valve location) is normally used to select the valve.

Proportional to bypass flow

Proportional mixing valves used to bypass flow are piped on the outlet side of the load to throttle the water flow through the load and therefore control heat output of the load. These valves are usually selected to take a pressure drop equal to at least 50% of the available pressure. As available pressure is often difficult to calculate, the normal procedure is to select the valve using a pressure drop at least equal to the drop in the coil or other load being controlled (except where small booster pumps are used) with a minimum recommended pressure drop of 5 psi (34 kPa). When the design temperature drop is less than 60°F (33°C) for conventional heating systems, higher pressure drops across the valve are needed for good results (see conventional heating system pressure drops table below).

Conventional heating system pressure drops

Design temperature load drop °F (°C)	Recommended pressure drop* (% of available pressure)	Multiplier on load drop
60 (33) or more	50%	1 x load drop
40 (22)	66%	2 x load drop
20 (11)	75%	3 x load drop

* Recommended minimum pressure drop = 5 psi (34 kPa).

Secondary circuits with small booster pumps: 13 50% of available pressure difference (equal to the drop through load, or 50% of booster pump head).

VB-9313 Water Flow Coefficient and Capacity

Proportional to blend water flows

Proportional valves used to blend two water flows control the heat output by varying the water temperature to the load at constant flow. These valves do not require high pressure drops for good control results. They can be sized for a pressure drop of 20% of the available pressure or equal to 25% of the pressure drop through the load at full flow.

Water table

Water capacity in gallons per minute for VB-9313 Series

Valve body part number	Cv Rating	Differential pressure (ΔP in psi)															
		1	2	3	4	5	6	7	8	9	10	15	20	25	30	35	
VB-9313-0-5-12	74	74	105	128	148	165	181	196	209	222	234	287	331	370	405	438	
VB-9313-0-5-13	101	101	143	175	202	226	247	267	286	303	319	391	452	505	553	598	
VB-9313-0-5-14	170	170	240	294	340	380	416	450	481	510	538	658	760	850	931	1006	
VB-9313-0-5-15	290	290	410	502	580	648	710	767	820	870	917	1123	1297	1450	1588	1716	
VB-9313-0-5-16	390	390	552	675	780	872	955	1032	1103	1170	1233	1510	1744	1950	2136	2307	

Cv equation

Where:

Cv = Coefficient of flow

GPM = U.S. gallons per minute (60°F, 15.6°C)

ΔP = Differential pressure in psi (pressure drop)

$$Cv = \frac{GPM}{\sqrt{\Delta P}} \quad \Delta P = \left(\frac{GPM}{Cv} \right)^2 \quad GPM = Cv \sqrt{\Delta P}$$

Cavitation limitations on valve pressure drop

A valve selected with too high a pressure drop can cause erosion of discs and/or wire drawing of the seat. In addition, cavitation can cause noise, damage to the valve trim (and possibly the body), and choke the flow through the valve.

Do not exceed the maximum differential pressure (pressure drop) for the valve selected.

The following formula can be used on higher-temperature water systems, where cavitation could be a problem, to estimate the maximum allowable pressure drop across the valve:

$$P_m = 0.5 (P_1 - P_v)$$

Where:

P_m = Maximum allowable pressure drop

P₁ = Absolute inlet pressure (psia)

P_v = Absolute vapor pressure (psia) (Refer to the table below.)

Note: Add 14.7 psi to the gauge supply pressure to obtain the absolute pressure value.

For example, if a valve is controlling 200°F water at an inlet pressure of 18 psig, the maximum pressure drop allowable would be:

$$P_m = 0.5 [(18 + 14.7) - 11.53] = 10.6 \text{ psi (Vapor pressure of 200°F water is 11.53 psi.)}$$

Therefore, if the pressure drop for this valve is less than 10.6 psi, cavitation should not be a problem.

Systems where cavitation is shown to be a problem can sometimes be redesigned to provide lower inlet velocities. Valves having harder seat materials should be furnished if inlet velocities cannot be lowered.

For additional valve sizing information, see the Vx-8xxx Selection Guide, F-27199.

VB-8xx3/9313 Close-Off Pressure Capability

Vapor pressure of water table

Water temp. (°F)	Vapor pressure (psia)	Water temp. (°F)	Vapor pressure (psia)	Water temp. (°F)	Vapor pressure (psia)	Water temp. (°F)	Vapor pressure (psia)
40	0.12	90	0.70	140	2.89	190	9.34
50	0.18	100	0.95	150	3.72	200	11.53
60	0.26	110	1.28	160	4.74	210	14.12
70	0.36	120	1.69	170	5.99	220	17.19
80	0.51	130	2.22	180	7.51	230	20.78

Seat leakage classes

ANSI/FCI 70-2 leakage class

Class II

Class III

Class IV

Class V

Maximum seat leakage

0.5% of rated Cv

0.1% of Rated Cv

0.01% of Rated Cv

0.0005 ml per minute per inch of orifice diameter per psi differential

Close-off ratings (unless otherwise specified)

Nominal actuator close-off ratings are based on ANSI V with EPDM discs; and PTFE discs in steam applications. Metal-to-metal trim, such as brass 3-Way and high-temperature stainless, are designed for ANSI III (0.1% leakage).

Note: Valve body and actuator size determine the close-off capabilities.

Overview VB-8/9000 Series Actuator Assemblies

Vx-8xx3 Series Balanced Globe Valve Assemblies

Schneider Electric VA, VF, VK, VK4, VS and VU-8xx3-xxx-5-P series valve assemblies are complete actuator/valve assemblies that accept Two-position, floating, and proportional electric/electronic and proportional pneumatic control signals, for control of chilled water, hot water, or low pressure steam. These valve assemblies consist of pneumatic, electric, or electronic valve actuators either direct-coupled or linked to a 2½" to 6" 2-Way or 3-Way valve body with ASA flanged end connections.

VB-8xx3 Series Valve Bodies

VB-8xx3-0-5-P Valve Bodies are also available separately to allow field mounting of a variety of Forta, Schneider Electric SmartX, or pneumatic actuators using the appropriate linkage.

Features

- Balanced plug design provides high close-offs using economical actuation
- Up to 125 psi (856 kPa) close-off on 2-Way models, 35 psi (240 kPa) on 3-Way models
- Universal 3-Way valve can be piped in either mixing or diverting configurations.
- Valve sizes 2½" to 6", ASA 125 flanged
- A variety of Forta, Schneider Electric SmartX and pneumatic actuators are available, either as factory assemblies or for field assembly.
- ANSI IV shutoff (0.01% of Cv) on 2-way models, ANSI III (0.1% of Cv) on 3-way models
- Self-adjusting spring loaded TFE/EPDM packing
- Normally open, normally closed, and non-spring return models available
- Expanded temperature range of 20° to 281°F
- ISO 9001:2000 Certified Quality Management System
- Vx-9313 3-Way valves offer many of the same features as the VB-8xx3 vales and a conventional mixing valve flow pattern.

2-Way and 3-Way Valves
 2½" to 6" Flanged
 2-Way Stem Up Open
 2-Way Stem Up Closed
 3-Way/Diverting
 Electric/Electronic/Pneumatic
 Globe Valve Assemblies

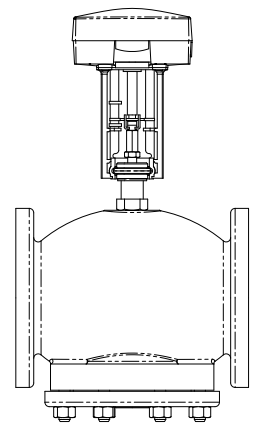

VB-8213 with M1500A Actuator

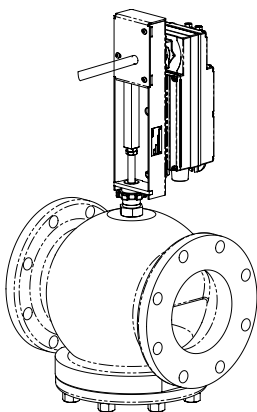

Vx-82x3 with Mx4x-6343 (2½" – 5" with AV-607-1 6" with AV-609-1)

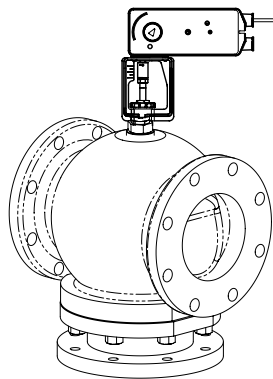

Vx-8303/Vx-9313 with Mx61-720x Direct-Mounted Actuator

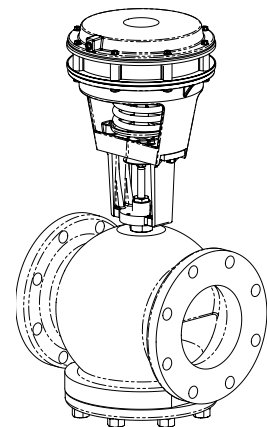

Vx-82xx with MK-6911

VB-8000, VB-9000 Assembly Selection Procedure

Globe Valve Assembly selection procedure

When selecting a globe valve assembly, you must determine the applicable codes for the Control signal type, valve body configuration, end connection, port size and actuator. Select a globe valve assembly part number as follows:

1. Control signal type, valve body configuration and end connection

Refer to "Ordering VB-8000, VB-9000 Valve Assemblies" on page 175 and select the appropriate codes for the part-number fields.

2. Valve size (flow coefficient)

If the required flow coefficient (Cv) has not been determined, do so as follows:

- Refer to Sizing and Selection to calculate the required Cv.
- Select the nearest available Cv value and corresponding valve body port code.

3. Actuator and linkages

Select the appropriate actuator and code, according to Assembly Ordering based on the Control signal type, required valve normal position, and voltage requirements. For detailed actuator information, refer to the applicable actuator specifications on subsequent pages.

Note: Linkages shown in Specification tables are supplied with the actuator. When shown in Optional Accessories the linkage must be ordered separately.

4. Close-off pressure

Confirm that the selected actuator and valve body combination provides sufficient close-off pressure. If no close-off pressure is shown, the valve body/actuator combination is not valid.

5. Available space

If available space is a consideration, check the appropriate dimensions in the separately available Wiring, Dimensions and Reference document F-28125 from the mySchneider download center.

Specify four part number fields

(1, 2, 4, and 6 below) to determine the Valve Actuator Assembly part number.

1) Control Signal	2) Trim and Valve Configuration	3) Pipe End Connections	4) Actuator or Linkage	5) Pattern Code	6) Port Code Cv Value
V <input type="text"/> <input type="text"/> - <input type="text"/> <input type="text"/> <input type="text"/>	<input type="text"/> <input type="text"/> <input type="text"/>	<input type="text"/> 3 -	<input type="text"/> <input type="text"/> <input type="text"/>	- <input type="text"/> 5 -	<input type="text"/> <input type="text"/>
Refer to the guide below.		Flanged for all valves.	Refer to the following pages for Spring & Non-Spring Return Electric and Pneumatic Spring Return Actuator codes, based on required close-off pressure.	Specify Option 5 (Flanged) for all valves.	For water, steam, glycol and similar non flammable, non toxic fluids, choose based on capacity sizing in this chapter. Below 2½", go to the valve size and selection chart on page 95..

Ordering VB-8000, VB-9000 Valve Assemblies

V - 3 - - 5 -

A = Two-position
F = Floating
S = Proportional
K = Pneumatic
K4 = Positive Positioner for pneumatic actuators

Trim and Configuration
821 = 2-Way, Stem Up Open, Brass Trim EPDM Seat
822 = 2-Way, Stem Up Closed, Brass Trim EPDM Seat
830 = 3-Way, Mixing or Diverting, Brass Trim (Bottom port is "Common")
931 = 3-Way, Mixing, Brass Trim, Metal-to-Metal (One end port is "Common")

Pipe Connection End Fitting
3 = Flanged

Actuator code
xxx = Replace with Actuator code.

Connection
5 = Flanged

Port Code
2½" to 6" (Cv 56 to 500)
12 = 2½"
13 = 3"
14 = 4"
15 = 5"
16 = 6"

VB-8xx3/9313 Close-Off Ratings

The following tables offer a quick guide to valve actuator combination/close-off ratings. Please refer to specific close-off ratings.

VB-8xx3 and VB-9313 Close-Off ratings

Spring Return Electric

Actuator	Mx41-715x				Mx40-717x				Mx61-720x
Linkage	AV-607-1 ^d		AV-609-1 ^e		AV-607-1 ^d		AV-609-1 ^e		Included with actuator
No act	Single	Dual	Single	Dual	Single	Dual	Single	Dual	Single
Pipe size	VB-82x3 ^a								
2 1/2"	125/35				125/35				125/35
3"									
4"									
5"									
6"			125/22	125/35			125/25	125/35	
Pipe size	VB-8303 ^a								
2 1/2"	35/35				35/35				35/35
3"									
4"									
5"	32/28			35/31				35/35	
6"	35/35		15/11			16/12		35/31	
Pipe size	VB-9313 ^{b,f}								
2 1/2"	33	70			40	84			
3"	22	48			27	57			
4"	12	27			15	33			
5"			9				10		
6"			6				7		

Non-Spring Return Electric

Pneumatic Spring Return @15psi air (with 5 to 10 psi spring)

Actuator	Mx41-6153	Mx41-6343	M800A	M1500A	MK-6811	MK-8811	MK-6911	MK-8911
Linkage	AV-607-1 ^d	AV-609-1 ^e	AV-822	AV-822	AV-497 ^c	AV-496	AV-497	AV-496
No act	Single	Dual	Single	Dual	Single			
Pipe size	VB-82x3 ^a							
2 1/2"	125/35				125/35			
3"								
4"								
5"								
6"			125/25	125/35			125/35	
Pipe size	VB-8303 ^a							
2 1/2"	35/35				35/35			
3"								
4"								
5"								
6"							35/35	
Pipe size	VB-9313 ^{b,f}							
2 1/2"	33	70	46	96	29	61	40d/30u*	91d/60u*
3"	22	48	31	66	19	42	27d/20u*	62d/40u*
4"	12	27	18	38	10	22	14d/10u*	33d/25u*
5"	9		24		14		20d/15u*	
6"	6		17		9		13d/10u*	

a - VB-8xxx - First value = maximum Close off pressure, Second value = maximum operating differential. (Example: 125/35).

b - VB-9213/VB-9223 2-Way valves have the same close offs as VB-9313 valves.

c - VB-8xx3 valves use AV-497 linkage, VB-9313 valves use AV-495 linkage.

d - AV-607-1 (2 1/2" to 5" VB-8000 valves or 2 1/2" to 4" VB-9313 valves), the Mx41-634x actuator is not compatible with the AV-607-1 linkage.

e - AV-609-1 (6" VB-8000 valves or 5" to 6" VB-9313 valves), the AV-609-1 linkage can be used with the Mx41-634x actuator on 2 1/2" to 5" VB-8000 valves or 2 1/2" to 4" VB-9313 valves, but the valve will stroke over a shorter portion of the control Input signal

f - Stem up (B to AB flow, A port closed. stem down (A to AB flow, B port closed)

*d and u indicate d (stem down) u (stem up)



U-Bolt Mount

More information on VB-8303:
Scan the QR code or visit the link below.



Visit:
<http://goo.gl/3fMhfY>

More information on VB-8213:
Scan the QR code or visit the link below.



Visit:
<http://goo.gl/VEAV7e>

VB-82x3 2-Way Globe Valves with NSR Actuators

Actuator combinations and operating pressure differentials

Choose a valve assembly with a maximum operating differential pressure capability sufficient for the application. Consult close-off pressure ratings. Not all actuator and valve body combinations are offered as factory assemblies.

2-Way Globe Valve Assemblies with Non-Spring Return Actuators

Non-Spring Return (NSR) 2-Way Globe Valve Assemblies	M1500A		Mx41-634x				
	Actuator output rating (minimum)						
	337 lbf (1500 N)		300 lb-in (34 N-m)				
	Actuator model (Actuator code)						
	Floating/ Proportional M1500A (686)		Floating MF41-6343 Proportional MS41-6340 (512) MS41-6343				
	Linkage Kit part number						
AV-822 (2½" to 6")		AV-609-1 (6")					
Close-off pressure (psi)							
125							
Valve Assembly part number ^a	P code	Valve size in.	Cv ^b	kvs ^b	Maximum allowable operating differential ^c		
					M1500A	Single Actuator	Dual Actuator ^d
Vx-8213-xxx-5-P Vx-8223-xxx-5-P	12	2½	56	48	35 (240)		
	13	3	85	74			
	14	4	145	125			
	15	5	240	208			
	16	6	370	320			
					35 (240)	35 (240)	

a - See "VB-8000, VB-9000 Assembly Selection Procedure" on page 175 for the relevant part series to determine a specific part no.

b - $C_v = \frac{gpm}{\Delta P}$ (where ΔP is measured in psi) $kvs = Cv / 1.156$ $K_{vs} = \frac{m^3/h}{\Delta P}$ (where ΔP is measured in bar; 1 bar = 100 kPa).

c - Maximum allowable differential across the valve in any open position. Less than 20 psi recommended for quieter service. Consult close-off pressure ratings.

d - Dual actuators are not available as a factory assembly.

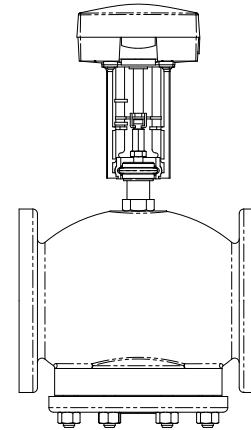

VB-8213 with M1500A Actuator

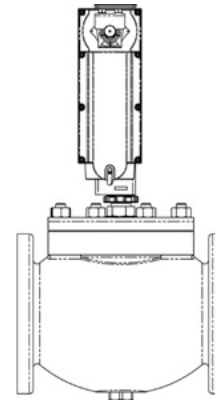

VB-8223 with Mx41-634x Actuator

VB-8303 3-Way Globe Valves with NSR Actuators

3-Way Globe Valve Assemblies

Choose a valve assembly with a maximum operating differential pressure capability sufficient for the application. Consult close-off pressure ratings. Not all actuator and valve body combinations are offered as factory assemblies.

3-Way Globe Valve Assemblies with Non-Spring Return Actuators

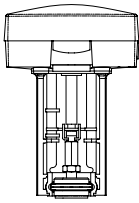
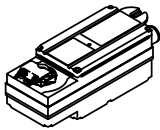
Non-Spring Return (NSR) 3-Way Globe Valve Assemblies					M1500A	Mx41-634x						
												
					Actuator output rating (minimum)							
					337 lb ^f (1500 N)		300 lb-in (34 N-m)					
					Actuator model (Actuator code)							
					Floating/ Proportional M1500A (686)		Floating MF41-6343 (516) Proportional MS41-6340 (512) MS41-6343 (516)					
Linkage kit part number												
AV-822 (2½" to 6")		AV-609-1 (6")										
Close-off pressure (psi)					35							
Valve assembly part number^a	P code	Valve size in.	Cv^b	kvs^b	Maximum allowable operating differential pressure^c (psi)(mixing/diverting)							
					M1500A	Single Actuator	Dual Actuator ^d					
Vx-8303-xxx-5-P	12	2½	80 ^e	69 ^e	35 (240)	-						
			95 ^f	82 ^f								
			115 ^g	99 ^g								
	13	3	110 ^e	95 ^e								
			120 ^f	104 ^f								
			120 ^g	104 ^g								
			14	4					190 ^h	164 ^h		
	15	5	290 ^h	251 ^h								
	16	6	500 ^h	433 ^h					32 (219) 28 (192)	35 (240)		

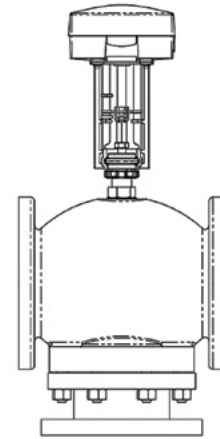

Vx-8303 with M1500A Actuator

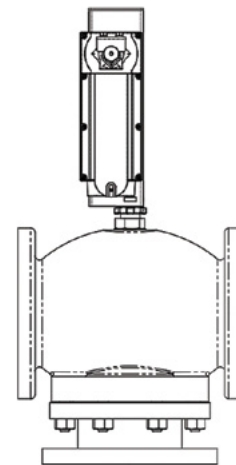

Vx-8303 with Mx41-634x Actuator

VB-8000 3-Way Flow Patterns

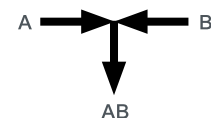

VB-8303 2½...6" 3-Way Mixing Stem Up
Flow is B Port to Common Bottom AB Port

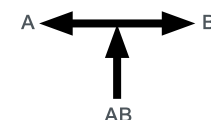

VB-8303 2½...6" 3-Way Diverting Stem Up
Flow is Common Bottom AB Port to B Port

a - See "VB-8000, VB-9000 Assembly Selection Procedure" on page 175 for the relevant part series to determine a specific part number.

b - $C_v = \frac{gpm}{\Delta P}$ (where ΔP is measured in psi) $kvs = Cv / 1.156$ $K_{vs} = \frac{m^3/h}{\Delta P}$ (where ΔP is measured in bar; 1 bar = 100 kPa).

c - Maximum allowable differential across the valve in any open position. Recommend less than 20 psi for quieter service. Consult close-off pressure ratings.

d - Dual actuators are not available as a factory assembly.

e - Mixing configuration, ports A and B are inlets, AB port is outlet.

f - Diverting configuration, flow AB to A port.

g - Diverting configuration, flow AB to B port.

h - All flow configurations, mixing or diverting.

VB-82x3 2-Way Globe Valves with SR Actuators

2-Way Globe Valve Assemblies with Spring Return Actuators

Spring Return
2-Way Globe Valve Assemblies

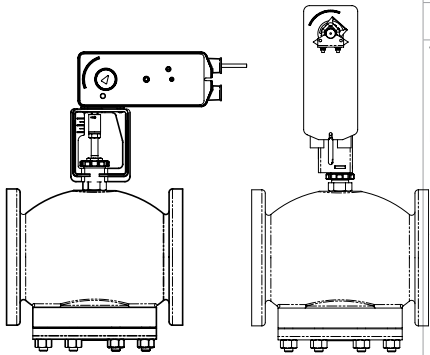

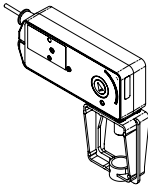
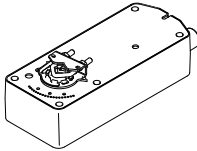
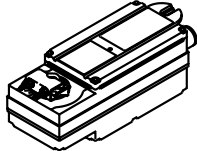
					Mx61-720x	Mx41-715x	Mx40-717x		
									
					Actuator output rating (minimum)				
					220 lbf (979 N)	133 lb-in (15 N-m)	150 lb-in (17 N-m)		
					Actuator models (Actuator codes)				
					Two-position MA61-7200 MA61-7203 (596) Floating MF61-7203 (596) Proportional MS61-7203 (596) MS61-7203-040 MS61-7203-050	Two-position MA41-7150 MA41-7151 MA41-7153 (556) MA41-7150-502 MA41-7151-502 MA41-7153-502 Floating MF41-7153 (556) MF41-7153-502 Proportional MS41-7153 (556) MS41-7153-502	Two-position MA40-7170 MA40-7173 (576) Floating MF40-7173 (576) Proportional MS40-7170 MS40-7171 MS40-7173 (576)		
					Linkage kit part number				
					None (Part of Actuator)	AV-607-1 (2½" to 5") AV-609-1 (6")	AV-607-1 (2½" to 5") AV-609-1 (6")		
Close-off pressure (psi)					125				
					Maximum allowable operating differential pressure, psi (kPa)				
Valve assembly part number^a	P code	Valve size in.	Cv^b	kvs^b	Mx61-720x	Single Actuator	Dual Actuator ^d	Single Actuator	Dual Actuator ^d
Vx-8213-5xx-5-P Vx-8223-5xx-5-P	12	2½	56	48	35 (240)	35 (240)	-	35 (240)	-
	13	3	85	74					
	14	4	145	125					
	15	5	240	208					
	16	6	370	320	-	22 (151)	35 (240)	25 (171)	35 (240)

a - See "VB-8000, VB-9000 Assembly Selection Procedure" on page 175 for the relevant part series to determine a specific part number.

b - $C_v = \frac{gpm}{\Delta P}$ (where ΔP is measured in psi) $kvs = Cv / 1.156$ $K_{vs} = \frac{m^3/h}{\Delta P}$ (where ΔP is measured in bar; 1 bar = 100 kPa).

c - Maximum allowable differential across the valve in any open position. Less than 20 psi recommended for quieter service. Consult close-off pressure ratings.

d - Dual actuators are not available as factory assemblies.

VB-8303 3-Way Globe Valves with SR Actuators



3-Way Globe Valve Assemblies

Choose a valve assembly with a maximum operating differential pressure capability sufficient for the application. Consult close-off pressure ratings. Not all actuator and valve body combinations are offered as factory assemblies.

3-Way Globe Valve Assemblies with Spring Return Actuators

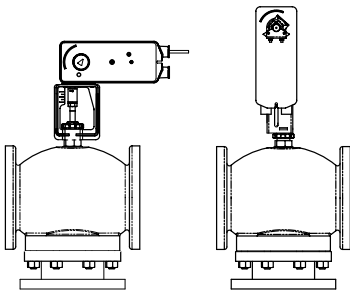
Spring Return (SR)
3-Way Globe Valve Assemblies

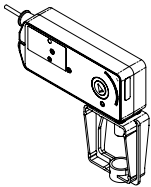
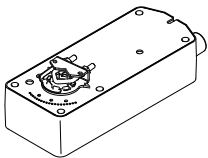

Mx61-720x	Mx41-715x	Mx40-717x
		
Actuator output rating (minimum)		
220 lbf (979 N)	133 lb-in (15 N-m)	150 lb-in (17 N-m)
Actuator models (Actuator codes)		
Two-position MA61-7200 MA61-7203 (596) Floating MF61-7203 (596) Proportional MS61-7203 (596) MS61-7203-040 MS61-7203-050	Two-position MA41-7150 MA41-7151 MA41-7153 (556) MA41-7150-502 MA41-7151-502 MA41-7153-502 Floating MF41-7153 (556) MF41-7153-502 Proportional MS41-7153 (556) MS41-7153-502	Two-position MA40-7170 MA40-7173 (576) Floating MF40-7173 (576) Proportional MS40-7170 MS40-7171 MS40-7173 (576)
Linkage kit part number		
None (Part of Actuator)	AV-607-1 (2½" to 5") AV-609-1 (6")	AV-607-1 (2½" to 5") AV-609-1 (6")
Close-off pressure (psi)		
35		

Valve assembly part number ^a	P code	Valve size in.	Cv ^b	kvs ^b	Maximum allowable operating differential pressure ^c , psi (kPa) (mixing/diverting)									
					Mx61-720x	Single Actuator	Dual Actuator ^d	Single Actuator	Dual Actuator ^d					
Vx-8303-5xx-5-P	12	2½	80e	69e	35 (240) / 35 (240)	35 (240) / 35 (240)	-	35 (240) / 35 (240)	-					
			95f	82f										
			115g	99g										
	13	3	110e	95e										
			120f	104f										
			120g	104g										
	14	4	190h	164h										
	15	5	290h	251h										
	16	6	500h	433h						-	15 (103) / 11 (75)	-	16 (110) / 12 (82)	35 (240) / 31 (214)

- a- See "VB-8000, VB-9000 Assembly Selection Procedure" on page 175 for the relevant part series to determine a specific part number.
- b- $C_v = \frac{gpm}{\Delta P}$ (where ΔP is measured in psi) $kvs = Cv / 1.156$ $K_{vs} = \frac{m^3/h}{\Delta P}$ (where ΔP is measured in bar; 1 bar = 100 kPa).
- c- Maximum allowable differential across the valve in any open position. Recommend less than 20 psi for quieter service. Consult close-off pressures.
- d- Dual actuators are not available as factory assemblies.
- e- Mixing configuration, ports A and B are inlets, AB port is outlet.
- f- Diverting configuration, flow AB to A port.
- g- Diverting configuration, flow AB to B port.
- h- All flow configurations, mixing or diverting.



VB-8303 2½"...6" 3-Way Mixing Stem Up VB-8303 2½"...6" 3-Way Diverting Stem Up
Flow is B Port to Common Bottom AB Port Flow is Common Bottom AB Port to B Port

Vx-9313 3-Way Globe Valves with Linear SR Actuators

3-Way Linked Globe Valve Assemblies with Linear Series Actuators

Choose a valve assembly with a maximum operating differential pressure capability sufficient for the application. Consult close-off pressure ratings. Not all actuator and valve body combinations are offered as factory assemblies.

3-Way Globe Valve Assemblies with Linear Spring Return Actuators

3-Way Linked Globe Valve Assemblies^a

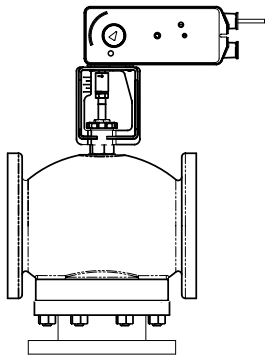

Mx61-720x

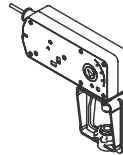

Actuator force rating

220 lbf (979 N)

Actuator model (Actuator code)

Two-position

MA61-7200
MA61-7201
MA61-7203 (596)

Floating

MF61-7203 (596)

Proportional

MS61-7203 (596)
MS61-7203-040
MS61-7203-050

Valve assembly part number ^b	P code	Valve size in. (mm)	Cv ^c	kvs ^c	Actuator Close-off pressure (psi) ^{ad}
Vx-9313-xxx-5-P	12	2½ (65)	74.0	64	33
	13	3 (80)	101.0	87	22
Vx-9313-xxx-5-P	14	4 (N/A)	145.0	125	12

a - For piping information refer to the separately available Wiring, Dimensions and Reference document F-28125 from the mySchneider download center.

b - To determine a specific part number, see "VB-8000, VB-9000 Assembly Selection Procedure" on page 175 for the relevant part series.

c - $C_v = \frac{gpm}{\Delta P}$ (where ΔP is measured in psi) $kvs = Cv / 1.156$ $K_{vs} = \frac{m^3/h}{\Delta P}$ (where ΔP is measured in bar; 1 bar = 100 kPa).

d - Close-off pressure ratings describe only the differential pressure which the actuator can close-off with adequate seating force. Consult valve body specifications for other limitations. The rating value is the pressure difference between the inlet and outlet ports.

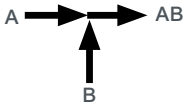

VB-9313 2½...6" 3-Way Mixing Stem Up
Flow is B Port to Common AB Port

Vx-9313 3-Way Globe Values with Linked SR Actuators

3-Way Linked Globe Valve Assemblies with Spring Return Actuators

Spring Return
3-Way Linked Globe Valve Assemblies

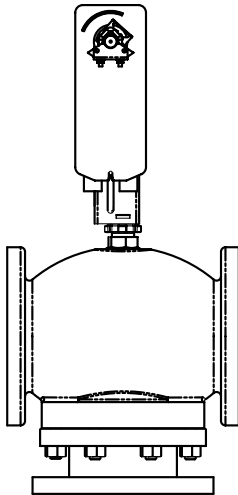

Mx41-707x	Mx41-715x	Mx40-717x
Actuator Torque Rating (minimum)		
60 lb-in (7 N-m)	133 lb-in (15 N-m)	150 lb-in (17 N-m)
Actuator Model (Actuator Code)		
Two-Position MA41-707x (544)	Two-Position MA41-7150 MA41-7151 MA41-7153 (556) MA41-7150-502 MA41-7151-502 MA41-7153-502	Two-Position MA40-717x
Floating MF41-7073	Floating MF41-7153 (556) MF41-7153-502	Floating MF40-7173
Proportional MS41-7073	Proportional MS41-7153 (556) MS41-7153-502	Proportional MS40-717x (576)
Linkage Kit Part Number		
AV-607-1 (2½" ...4")	AV-607-1 (2½" ...4") AV-609-1 (5" and 6")	AV-607-1 (2½" ...4") AV-609-1 (5" and 6")

Valve Assembly Part Number ^b	P Code	Valve Size in. (mm)	Cv ^c	kv _s ^c	Actuator Close-off Pressure (psig) ^d					
					Single Actuator	Dual Actuator ^e	Single Actuator	Dual Actuator ^e	Single Actuator	Dual Actuator ^e
Vx-9313-xxx-5-P	12	2½ (65)	74.0	64	24	52	33	70	40	84
	13	3 (80)	101.0	87	16	35	22	48	27	57
	14	4 (N/A)	145.0	125	9	20	12	27	15	33
	15	5 (N/A)	235.0	203				9	-	10
	16	6 (N/A)	350.0	303				6	-	7

- a - For piping information refer to the separately available Wiring, Dimensions and Reference document F-28125 from the mySchneider download center.
- b - To determine a specific part number, see "VB-8000, VB-9000 Assembly Selection Procedure" on page 175 for the relevant part series.
- c - $kvs = m^3/h (\Delta P = 100 \text{ kPa})$ $kvs = Cv / 1.156$ $Cv = kvs \times 1.156$
- d - Close-off ANSI III (0.1%) for metal-to-metal seats with pressure at inlet (port A).
- e - Dual actuators are not available as factory assemblies.



Vx-9313 3-Way Globe Values with Linked SR Actuators

3-Way Linked Globe Valve Assemblies with Non-Spring Return Actuators

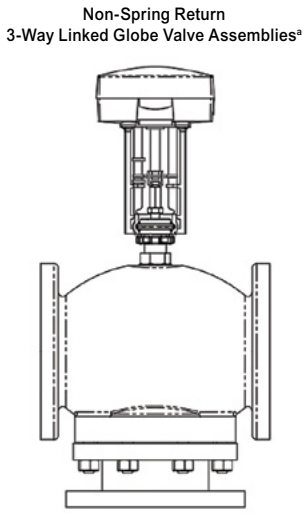
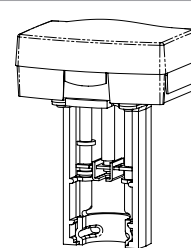
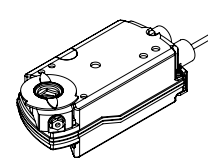
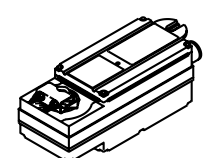
 <p>Non-Spring Return 3-Way Linked Globe Valve Assemblies^a</p>					M800A / M1500A		Mx41-6153		Mx41-6343	
										
					Actuator Torque Rating (minimum)					
					180 lbf (800 N)	337 lbf (1500 N)	133 lb-in (15 N-m)		300 lb-in. (34 N-m)	
					Actuator Model (Actuator Code)					
					Universal M800A (680)	Universal M1500A (686)	Floating MF41-6153 Proportional MS41-6153		Floating MF41-6343 Proportional MS41-6343	
					Linkage Kit Part Number					
					AV-822	AV-822	AV-607-1 (2½"...4")		AV-609-1 f (2½"...6")	
					Actuator Close-off Pressure psia ^d					
Valve Assembly Part Number ^b	P Code	Valve Size in.	Cvc	kv _s ^c	AV-822	AV-822	Single Actuator	Dual Actuator ^e	Single Actuator	Dual Actuator ^e
Vx-9313-xxx-5-Pf	12	2½	74.0	64	29	61	33	70	46	96
	13	3	101.0	87	19	42	22	48	31	66
	14	4	145.0	125	10	22	12	27	18	38
	15	5	235.0	203	-	14	-	9	-	24
	16	6	350.0	303	-	9	-	6	-	17

a - For piping information refer to the separately available Wiring, Dimensions and Reference document F-28125 from the mySchneider download center.

b - To determine a specific part number, see "VB-8000, VB-9000 Assembly Selection Procedure" on page 175 for the relevant part series.

c - $kvs = m^3/h$ ($\Delta P = 100 \text{ kPa}$) $kvs = Cv / 1.156$ $Cv = kvs \times 1.156$

d - Close-off ANSI III (0.1%) for metal-to-metal seats with pressure at inlet (port A).

e - Dual actuators are not available as factory assemblies.

f - Mx41-634x actuators used on 2½" to 4" Vx-9313 will stroke over a shorter portion of the control input signal.

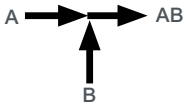

VB-9313 2½...6" 3-Way Mixing Stem Up
Flow is B Port to Common AB Port

VB-82x3 2-Way Globe Valves with Pneumatic SR Actuators

2-Way Valves

Choose a valve assembly with a maximum operating differential pressure capability sufficient for the application. Consult the table below for close-off pressure ratings. Not all actuator and valve body combinations are offered as factory assemblies.

2-Way Globe Valve Assemblies with Pneumatic Spring Return Actuators

Pneumatic Spring Return
2-Way Globe Valve Assemblies
(shown with Positive Positioner)

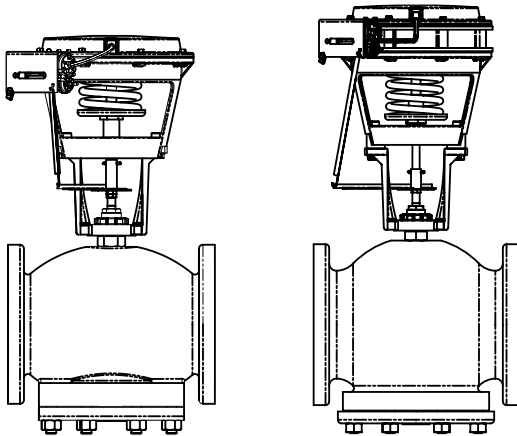

MK-6811 ^b	MK-6911 ^b
Actuator models (Actuator codes)	
MK-6811 (602)	MK-6911 (652)
Linkage kit part number	
AV-497	AV-497
Spring range, psig (kPa)	
5 to 10 (34 to 69) ^a	5 to 10 (34 to 69) ^a

Close-off pressure (psi)					125	
Valve assembly part number ^b	P Code	Valve size in.	Cv ^c	kvs ^c	Maximum allowable operating differential pressured, psi (kPa)	
VK-8213-602-5-12 VK-8223-602-5-12 VK4-8213-602-5-12 VK4-8223-602-5-12	12	2½"	56	48	35 (240)	-
VK-8213-602-5-13 VK-8223-602-5-13 VK4-8213-602-5-13 VK4-8223-602-5-13	13	3"	85	74		
VK-8213-602-5-14 VK-8223-602-5-14 VK4-8213-602-5-14 VK4-8223-602-5-14	14	4"	145	125		
VK-8213-602-5-15 VK-8223-602-5-15 VK4-8213-602-5-15 VK4-8223-602-5-15	15	5"	240	208		
VK4-8213-652-5-16 VK4-8223-652-5-16	16	6"	370	320	-	35 (240)

a - Spring range field adjustable with Positive Positioner.

b - AK-42309-500 Positive Positioner optional for 2½" to 5" valve, required for 6" valve. Supplied as standard on VK4 factory valve assemblies. See "VB-8000, VB-9000 Assembly Selection Procedure" on page 175 for the relevant part series to determine a specific part number.

c - $C_v = \frac{gpm}{\Delta P}$ (where ΔP is measured in psi) $kvs = C_v / 1.156$ $K_{vs} = \frac{m^3/h}{\Delta P}$ (where ΔP is measured in bar; 1 bar = 100 kPa).

d - Maximum allowable differential across the valve in any open position. Less than 20 psi recommended for quieter service. Consult close-off pressure ratings.



VB-8303 2½"...6" 3-Way Mixing Stem Up Flow is B Port to Common Bottom AB Port VB-8303 2½"...6" 3-Way Diverting Stem Up Flow is Common Bottom AB Port to B Port

VB-8303 3-Way Globe Valves with Pneumatic SR Actuators

3-Way Valves

Choose a valve assembly with a maximum operating differential pressure capability sufficient for the application. Not all actuator and valve body combinations are offered as factory assemblies.

3-Way Globe Valve Assemblies with Pneumatic Spring Return Actuators

Spring Return
3-Way Globe Valve Assemblies
(shown with Positive Positioner)

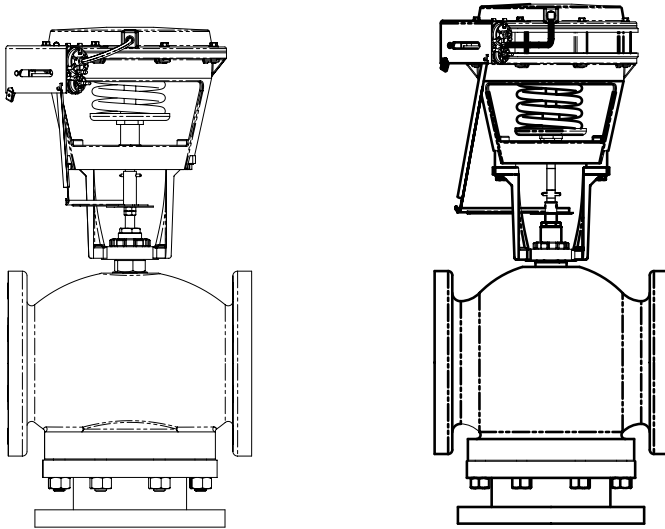

MK-6811^o

MK-6911^o

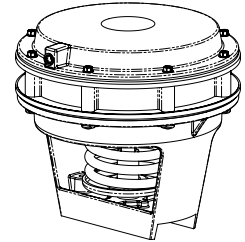
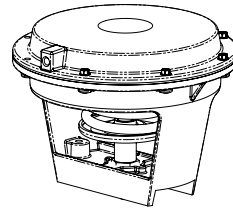

Actuator models (Actuator codes)

MK-6811 (602)

MK-6911 (652)

Linkage kit part number

AV-497

AV-497

Spring range, psig (kPa)

5 to 10 (34 to 69)^a

5 to 10 (34 to 69)^a

Close-off pressure (psi)

35

Valve assembly part number ^b	P code	Valve size in.	Cv ^c	kvs ^c	Maximum allowable operating differential pressured, psi (kPa) (mixing/diverting)
VK-8303-602-5-12	12	2½	80 ^e	69 ^e	35 (240) / 35 (240)
			95 ^f	82 ^f	
			115 ^g	99 ^g	
VK-8303-602-5-13	13	3	110 ^e	95 ^e	
			120 ^f	104 ^f	
			120 ^g	104 ^g	
VK-8303-602-5-14	14	4	190 ^h	164 ^h	-
VK-8303-602-5-15 VK4-8303-602-5-15	15	5	290 ^h	251 ^h	
VK4-8303-652-5-16	16	6	500 ^h	433 ^h	

a - Spring range field adjustable with Positive Positioner.

b - AK-42309-500 Positive Positioner optional for 2½" to 5" valve, required for 6" valve. Supplied as standard on VK4 factory valve assemblies. See "VB-8000, VB-9000 Assembly Selection Procedure" on page 175 for the relevant part series to determine a specific part number.

c - $C_v = \frac{gpm}{\Delta P}$ (where ΔP is measured in psi) $kvs = Cv / 1.156$ $K_{vs} = \frac{m^3/h}{\Delta P}$ (where ΔP is measured in bar; 1 bar = 100 kPa).

d - Maximum allowable differential across the valve in any open position. Less than 20 psi recommended for quieter service. Consult close-off pressure ratings.

e - Mixing configuration, ports A and B are inlets, AB port is outlet.

f - Diverting configuration, flow AB to A port.

g - Diverting configuration, flow AB to B port.

h - All flow configurations, mixing or diverting.

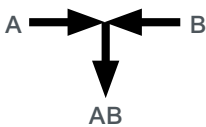

VB-8303 2½...6" 3-Way Mixing Stem Up
Flow is B Port to Common Bottom
AB Port

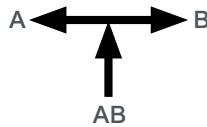

VB-8303 2½...6" 3-Way Diverting Stem Up
Flow is Common Bottom AB Port to B Port

VB-9313 3-Way Globe Valves with Pneumatic SR Actuators

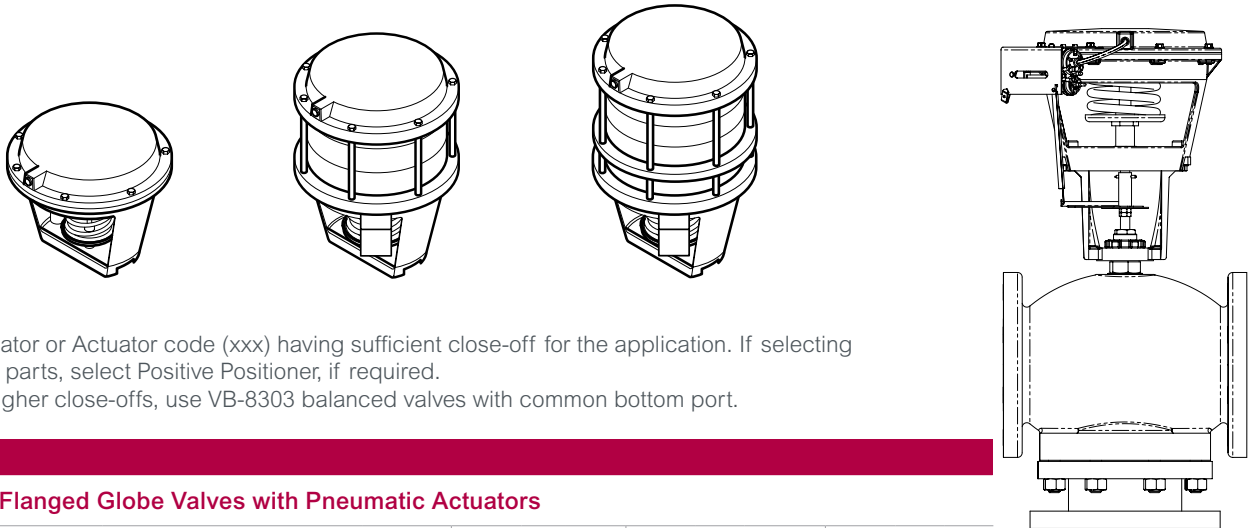

Select Actuator or Actuator code (xxx) having sufficient close-off for the application. If selecting component parts, select Positive Positioner, if required.

Note: For higher close-offs, use VB-8303 balanced valves with common bottom port.

VK4-9313 with a MK-6811 Pneumatic Actuator and AK-42309-500 Positive Positioner

2½" to 6" Flanged Globe Valves with Pneumatic Actuators

Actuator	MK-6811	MK-8811	MK-8911
Effective area (stroke)	50 Sq. In. (1" Stroke)	100 Sq. In. (1" Stroke)	100 Sq. In. (2" Stroke)
Positive Positioner	AK-42309-500		
Factory assembly with Positive Positioner	Yes	Yes	Yes
Actuator code (xxx)	602 ^f	802 ^a	812 ^a
Spring range (psig)	5 to 10	5 to 10	5 to 10

Actuator close-off pressure rating (psi)^{ab}

Supply air pressure (psig)	15/20	15	20	15/20	15	20	15/20	15	20			
Stem position ^c	SU	SD	SD	SU	SD	SD	SU	SD	SD			
Valve Assembly	Valve Body	P code	Size in.									
VK4-9313-xx2-5-Pd	VB-9313-0-5-P	-12	2½	30	40	91	60	91	125	-		
		-13	3	20	27	62	40	62				
		-14	4	10	14	33	25	33				
VK4-9313-812-5-Pd	VB-9313-0-5-P	-15	5	-						15	20	45
		-16	6							10	13	30

a - Close-off ratings for mixing valves: (SU = "A", SD = "B" port). "A" port (SU) ratings equal pressure at port "A" minus pressure at port "B". "B" port (SD) ratings equal pressure at port "B" minus pressure at port "A". Close-off ratings in the table are true only when the indicated supply air pressure is applied to the actuator. A change in air pressure at the actuator alters the actual close-off pressure.

b - Close-off pressure ratings describe only the differential pressure which the actuator can close-off to standards with adequate seating force. Consult valve body specifications for other limitations.

c - SU - Stem Up; SD - Stem Down. For piping information refer to the separately available Wiring, Dimensions and Reference document F-28125 from the mySchneider download center for flow pattern.

d - Factory valve assemblies are available only with Positive Positioner.

e - Includes AV-496 linkage.

f - Includes AV-495 linkage.

Optional Input signal Interface to Pneumatic Actuator

Input signal Type	Interface Module Required
Two-position, SPST (Electric)	AL-1xx
Two-position, SPDT Snap Acting (Electric)	AL-1xx

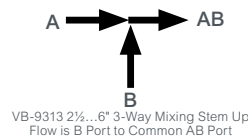

VB-9313 3-Way Valves with M900Axx SR Actuators

Schneider Electric VB-9313 Valve Bodies

Application		Chilled or Hot Water
Size		2½"...4"
Valve Body Part Number		VB-9313-0-5-P
Linkage Kit Part Number		AV-822
Material	Flow Characteristic	Nominally Linear
	Body	Cast Iron
	Seat	Bronze
	Stem	Stainless Steel
	Plug	Brass
	Packing	Spring Loaded TFE/EPDM
Disc		None
ANSI Pressure Class, psig		125
Allowable Control Media Temperature, °F (°C)		40°F...300°F (4°C...149°C)
Allowable Differential Pressure, Water, psi (kPa) ^a		35 psi (241 kPa) Max.
P Code	Valve Size, In.	C _v (k _{vs}) Rating ^b
12	2½	74 (64)
13	3	101 (87)
14	4	170 (147)

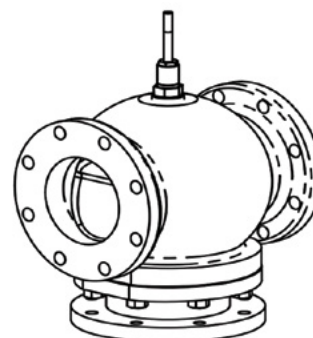

VB-9313

3-Way Valves

- 3-Way mixing
- ANSI 125 Flanged
- Cast Iron Body
- ASA Flanged

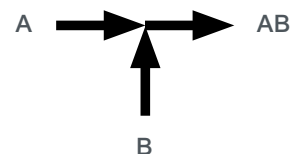

VB-9313 3-Way Mixing Flow Pattern

a - Maximum recommended differential pressure in open position. Do not exceed the recommended differential pressure (pressure drop) or integrity of parts may be affected. Exceeding maximum recommended differential pressure voids the product warranty.

b - $k_{vs} = m^3/h$ ($\Delta P = 100$ kPa) $k_{vs} = C_v / 1.156$ $C_v = \frac{gpm}{\sqrt{\Delta P}}$ (in psi). $k_{vs} = \frac{m^3/h}{\Delta P}$ (where ΔP is measured in bar; 1 bar = 100 kPa).

Schneider Electric SpaceLogic Actuator Model Table

Model	Actuator Code	Force	Power	Running Watts	Transformer Size	Floating Control ^{a,b}	Proportional Control ^b	Feed-back ^a	(2) SPDT Aux Switches ^c	Linkage ^e	Spring Return Action
M900AR	650	157 lbf (700 N)	24 Vac 50/60 Hz	21 W	50 Va	Yes	0...10 Vdc, 2...10 Vdc, 4...20 mA	2...10 Vdc or 0-5 Vdc	No	AV-822	Return
M900AE ^d	-										Extend
M900ARW	660								Return		
M900ARW-S2 ^d	-										Return
M900AEW-S2 ^d	-	Extend									

a - Dip switch selectable.

b - 0...5, 2...6 or 5...10, 6...10 also selectable by dip switch.

c - Order separately.

d - Factory assemblies not offered.

e - S2 auxiliary switches may be added in the field.

Restrictions on Ambient Temperature for SpaceLogicL Valve Actuators

Fluid Temperature in Valve Body	Maximum Allowable Ambient Temperature ^a
Chilled Water	122°F (50°C)
281°F (138°C)	113°F (45°C)
300°F (149°C)	107°F (42°C)
340°F (171°C)	100°F (38°C)
366°F (186°C)	90°F (32°C)

a - Minimum allowable ambient operating temperature 14°F (-10°C).

VB-9313 3-Way Valves with M900Axx SR Actuators

Select Valve Actuator Combination Having Sufficient close-off for Application						
Valve Body	Valve Action	P Code	Cv	Size	Close-off Ratings PSI	Maximum Operating Pressure Differential
					M900Axx ^a	
VB-9313-0-5-P	3 Way	12	67 (58)	2 ½"	29	35
		13	91 (79)	3"	19	35
		14	170 (147)	4"	10	35

a - Requires AV-822 Linkage Order Separately.

Factory Valve and Actuator Assemblies				
VB-9313 Series Valve Assembly Part Numbers ^a	P Code	Size	Valve Action Stem UP	M900AR (650) or M900ARW (660) Action on Power Loss
VU-9313-6x0-5-P (Mixing):	12	2 ½"	Flow B to AB	Flow B to AB
	13	3"		
	14	4"		

a - 650 = M900AR, 660 = M900ARW.

VB-9313 Valve Body and M900Axx Spring Return Actuator Actions								
Valve Body Part Number	Valve Body Description	Valve Body Stem Up Water Flow	M900ARx			M900AEx		
			Unpowered Valve Assembly Water Flow	Switch 7 off, Loss of Control Signal Only	Switch 7 on, Loss of Control Signal Only	Unpowered Valve Assembly Water Flow	Switch 7 off, Loss of Control Signal Only	Switch 7 on, Loss of Control Signal Only
VB-9313-0-5-P	3-Way Mixing	Flow B to AB	Flow B to AB	Flow B to AB	Flow A to AB	Flow A to AB	Flow A to AB	Flow B to AB

3-Way Flanged Valve Body Flow Patterns

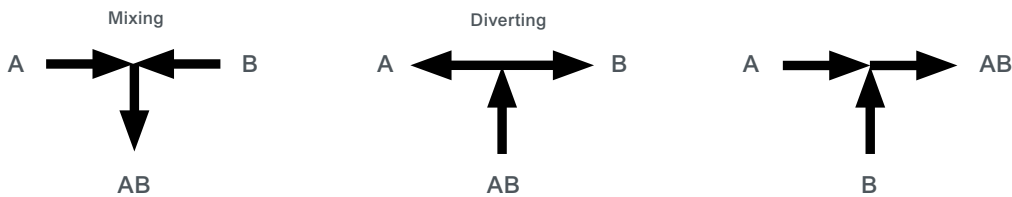

VB-8303 3-Way Flow Patterns
Flow is out AB for Mixing application and in AB for Diverting applications.

VB-9313 3-Way
Mixing Flow Patterns

Mx41-715x 133 lb-in SR SmartX Actuators

**Mx41-7153 Series
SmartX Actuator
(Code 556)
24 Vac
(Linkage not shown)**

**Mx41-7150 Series
SmartX Actuator
(Code 552)
120 Vac
(Linkage not shown)**



Specifications

Connection	3 ft. (0.9 m) Appliance cable	
Housing	Aluminum die-cast	
Enclosure rating	NEMA 2 with conduit connector down	
Dimensions	10½ x 4 x 3½ (267 x 110 x 89 mm)	
Linkage	AV-607-1 (2½" - 5" VB-8000 valves or 2½" - 4" VB-9313 valves) or AV-609-1 (6" VB-8000 valves or 5" - 6" VB-9313 valves)	
Position indicator	Visual indicator	
Override	Manual	
Motor type	Brushless	
Rotation	0 to 90°	
Control signal	MA41-7153: 2-position SPST MF41-7153: Floating MS41-7153: 2 to 10 VDC The 2 to 10 VDC Control signal is factory set for direct action. It can be changed in the field to reverse action.	MA41-7150: 2-position SPST
Voltage	24 Vac ± 20%, 22-30 VDC	120 Vac ± 10%
VA@60 HZ	9.7	10.0
Feedback	MA41 and MF41: None MS41: 2 to 10 VDC	None
Auxiliary switch	None	
Timing (seconds)	Powered <190 Spring return <30	
Installation instructions	F-26642	
	Note: Single mount actuators may be factory assembled, dual mount are field assembled.	Flanged Valve Close-off. 2-Way ratings are better than ANSI IV (0.01% leakage) with EPDM seating. 3-Way ratings are better than ANSI III (0.1% leakage) with metal seating.

VB-9313 3-Way Valves with M900Axx SR Actuators

Select Valve Actuator Combination Having Sufficient close-off for Application						
Valve Body	Valve Action	P Code	Cv	Size	Close-off Ratings PSI	Maximum Operating Pressure Differential
					M900Axx ^a	
VB-9313-0-5-P	3 Way	12	67 (58)	2 1/2"	29	35
		13	91 (79)	3"	19	35
		14	170 (147)	4"	10	35

a - Requires AV-822 Linkage Order Separately.

Factory Valve and Actuator Assemblies				
VB-9313 Series Valve Assembly Part Numbers ^a	P Code	Size	Valve Action Stem UP	M900AR (650) or M900ARW (660) Action on Power Loss
VU-9313-6x0-5-P (Mixing):	12	2 1/2"	Flow B to AB	Flow B to AB
	13	3"		
	14	4"		

a - 650 = M900AR, 660 = M900ARW.

VB-9313 Valve Body and M900Axx Spring Return Actuator Actions								
Valve Body Part Number	Valve Body Description	Valve Body Stem Up Water Flow	M900ARx			M900AEx		
			Unpowered Valve Assembly Water Flow	Switch 7 off, Loss of Control Signal Only	Switch 7 on, Loss of Control Signal Only	Unpowered Valve Assembly Water Flow	Switch 7 off, Loss of Control Signal Only	Switch 7 on, Loss of Control Signal Only
VB-9313-0-5-P	3-Way Mixing	Flow B to AB	Flow B to AB	Flow B to AB	Flow A to AB	Flow A to AB	Flow A to AB	Flow B to AB

3-Way Flanged Valve Body Flow Patterns

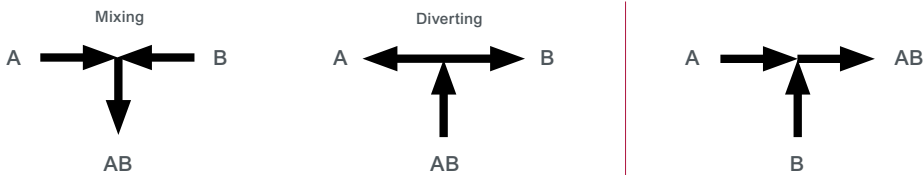

VB-8303 3-Way Flow Patterns
Flow is out AB for Mixing application and in AB for Diverting applications.

VB-9313 3-Way Mixing Flow Patterns

Mx40-717x 150 lb-in SR SmartX Actuators

**Mx40-7173 Series
SmartX Actuator
(Code 576)
24 Vac
(Linkage not shown)**

**Mx40-7170 Series
SmartX Actuator
120 Vac
(Linkage not shown)**



Specifications

Connection	3 ft. (0.9 m) Appliance cable	
Housing	Aluminum die-cast	
Enclosure rating	NEMA 1, NEMA 4 with customer supplied water tight connector	
Dimensions	10-7/8 x 4 x 4 (276 x 100 x 100 mm)	
Linkage	AV-607-1 (2½" - 5" VB-8000 valves or 2½" - 4" VB-9313 valves) or AV-609-1 (6" VB-8000 valves or 5" - 6" VB-9313 valves)	
Position indicator	Visual indicator	
Override	None	
Motor type	Brushless	
Rotation	0 to 90° CW	
Control signal	MA41-7173: 2-position SPST MF41-7173: Floating MS41-7173: 2 to 10 VDC/4 to 20 mA	MA40-7170: 2-position SPST MS40-7170: 2 to 10 VDC/4 to 20 mA
Voltage	24 Vac ± 20%, 22-30 VDC	120 Vac ± 10%
VA@60 HZ	MA40-7173: 7.4 (AC) MF40-7173: 8.1 (AC) MS40-7173: 7.8 (AC)	MA40-7170: 8.4 MS40-7170: 8.5
Watts @ 60 Hz	MA40-7173: 5.3 (AC) MF40-7173: 5.8 (AC) MS40-7173: 5.5 (AC)	MA40-7170: 6.2 MS40-7170: 6.4
Feedback	2 to 10 VDC	2 to 10 VDC (MS only)
Auxiliary switch	None	
Timing (seconds)	Powered 147 Spring return 65	Powered 162 Spring return 82
Installation instructions	MA40-7173: F-26742 MF40-7173: F-26749 MS40-7173: F-26748	MA40-7170: F-26742 MS40-7170: F-26748
	Note: Single mount actuators may be factory assembled, dual mount are field assembled.	Flanged Valve Close-off. 2-Way ratings are better than ANSI IV (0.01% leakage) with EPDM seating. 3-Way ratings are better than ANSI III (0.1% leakage) with metal seating. Note: Single mount actuators may be factory assembled, dual mount are field assembled.

Mx61-720x 220 lbf SR SmartX Actuators

More information:
Scan the QR code or visit the
link below.



Visit:

<http://goo.gl/dJri2c>

Mx61-7203 Series
SmartX Actuator
24 Vac

MA61-7200 Series
SmartX Actuator
120 Vac



Specifications

Connection	MS61-7203: 3 ft. (0.9 m) Plenum cable MS61-7203-040/050: 3 ft. (0.9 m) appliance wire	
Housing	Aluminum die-cast	
Enclosure rating	NEMA 2	
Dimensions	9-9/16 x 10-5/8 x 2-9/16 (243 x 270 x 65 mm)	
Linkage	(included)	
Position indicator	Visual indicator	
Override	Manual	
Motor type	Brushless	
Rotation	0 to 90° CW	
Control signal	MA61-7203: 2-position SPST MF61-7203: Floating MS61-7203: 2 to 10 VDC MS61-7203-040: 2 to 10 VDC MS61-7203-050: 0 to 10 VDC The 2 to 10 VDC Control signal is factory set for direction action. It can be changed in the field to reverse action.	2-position SPST
Voltage	24 Vac ± 20%, 22-30 VDC	120 Vac ± 10%
VA@60 HZ	9.7	10.0
Watts @ 60 Hz	7.7	8.4
Feedback	MA61 and MF61: None MS61: 2 to 10 VDC only. MS61-7203-040 has no feedback.	None
Auxiliary switch	None	
Timing (seconds)	Powered <190 Spring return <40	
Installation instructions	F-27120	

Mx61-634x 300 lb-in NSR SmartX Actuators

**Mx41-6343 Series
SmartX Actuator
(Code 516)
24 Vac**

**MS41-6340 Series
SmartX Actuator
(Code 512)
120 Vac**



Specifications		
Connection	24-inch (61 cm) Color-coded wires	3 ft. (91 cm) Color-coded wires
Housing	Aluminum die-cast	
Enclosure rating	NEMA 4 with customer supplied water tight connector or plug	
Dimensions	10-7/8 x 4 x 4 (276 x 100 x 100 mm)	
Linkage	AV-609-1 (6" VB-8000 or 5" - 6" VB-9313 valves), the AV-609-1 linkage can be used with the Mx41-634x actuator on 2½"-5" VB-8000 valves or 2½"-4" VB-9313 valves but the valve strokes over a shorter portion of the control input signal.	
Position indicator	Visual indicator	
Override	Manual	
Rotation	0 to 90° CW	
Control signal	MF41-6343: Floating MS41-6343: 2 to 10 VDC	MS41-6340: 2 to 10 VDC
Voltage	24 Vac ± 20%	120 Vac ± 10%
VA@60 HZ	MF41-6343: 7.1 MS41-6343: 8	4.7
Watts @ 60 Hz	MF41-6343: 3.8 MS41-6343: 8	8.4
Feedback	None	2 to 10 VDC
Auxiliary switch	None	
Timing (seconds)	<145	148
Installation instructions	F-26744 F-26745	F-26745

Note: Single mount actuators may be factory assembled, dual mount are field assembled.

Mx41-6153 133 lb-in NSR SmartX Actuators

Mx41-6153 Series
SmartX Actuator
(Code 512)
24 Vac

Mx41-6153



Specifications

Torque	133 lb-in. (15 N-m).
Connections	3 ft. (0.9 m) long, 18 AWG leads
Rotation	CW / CCW
Shaft size	1/4 to 3/8-in. (6.4 to 19 mm) dia., 1/4 to 1/2-in. (6.4 to 13 mm) sq.
Enclosure rating	NEMA Type 1, IP54 according to EN 60 529.
Dimensions	8-3/8 H x 3 1/4 W x 2-2/3 D" (210 x 80 x 70 mm)
Linkage	AV-607-1 (2 1/2" to 4" VB-9313 valves)
Position indication	Adjustable pointer
Override	Manual
Overload protection	Throughout rotation.
Angle of rotation	90° nominal (field adjustable to limit travel on either end of stroke).
Built-in auxiliary switches	Dual SPDT Auxiliary switches available on MS41-6153-502 only.
Operating temperature limits	-25 to 130°F (-32 to 55°C).
Wiring diagrams	MF41-6153, MS41-6153
Regulatory compliance	c-UL-us LISTED per UL 873 and CAN C22.2 No.24-93. CE compliant to directives LVD, EMC, and RoHS2.
Installation instructions	F-27215

Specifications - electrical and timing

Part number	Actuator inputs			Outputs		Approximate Timing in seconds	Weight lbs (kg)
	Control	Voltage	VA @ 60 Hz	Feedback	Auxiliary switch		
MF41-6153	Floating	24 Vac + 20% - 15%	3.0	None	No	<125 (60 Hz)	2.2 (1)
MS41-6153	0 to 10 VDC			0 to 10 VDC			
MS41-6153-502							

M800A, M1500A 180/337 lbf NSR SpaceLogic Actuators

M800A & M1500A Actuators
24 Vac - 20-29 VDC



VB-8000/VB-9313 Actuator Application

Valve Size	M800A* (180 lbf)	M1500A (337 lbf) Size
2½"	•	•
3"	•	•
4"	•	•
5"		•
6"		•

Specifications

Stroke (M800, M1500)	U-Bolt style: >3/8" to 2" (9-52mm)
Stroke Timing	Floating: 60 or 300 sec selectable, Proportional: 15 sec @½" stroke
Linkage	AV-822
Feedback AO	2 to 10 VDC
Power supply type	Half wave
Motor type	Brushless DC
Enclosure	NEMA 2 (IP 54, vertical mount only) with both conduit connectors used. NEMA 1 IP40 with one connector used.
Sound power level	Maximum 32 dba
Ambient temperature storage	-13 °F to 149 °F (-25 to 65 °C) ambient
Ambient temperature operational	122°F (50°C) For chilled water applications 113°F (45°C) ambient at 281°F (138°C) Fluid temperature 107°F (42°C) ambient at 300°F (149°C) Fluid temperature 100°F (38°C) ambient at 340°F (171°C) Fluid temperature 90°F (32°C) ambient at 366°F (186°C) Fluid temperature
Minimum operating temperature	14° to 150° F (-10° to 50° C)
Ambient humidity	15 to 95 % RH non-condensing
Housing material	Die-cast aluminum
Cover material	UL94 plenum rated plastic
Regulatory compliance	c-UL-us LISTED per UL 873 and CAN C22.2 No.24-93, CE compliant to LVD, EMC, and RoHS2 directives, and RCM marked for AUS/NZ.

Specifications - electrical and control

Model	M800A	M800A-S2	M1500A	M1500A-S2
AC power	24 Vac +- 10% 50-60 Hz			
DC power	20 - 29 VDC 20 W		20 - 29 VDC 30 W	
Running VA	15		24	
Transformer size VA	50			
Floating control	Yes			
Proportional control	0 to 10 VDC, 2 to 10 VDC or 4 to 20mA with 500 ohm resistor			
Feedback	2 to 10 VDC			
Force	180 lbf (800 N)		337 lbf (1500 N)	
2-SPDT aux switch	No	24 Vac 4a res	No	24 Vac 4a res

SpaceLogic M900A Series Spring Return Actuators

Product Description

The M900A series is a linear electro-mechanical actuator with “fail-safe” spring return operation for the control of 2-way and 3-way globe valves in:

- Hot water and steam systems
- Heating and cooling systems
- Air handling systems

M900A series utilize brushless DC motors and a high resolution control board to provide a very precise fluid control in globe valves. The actuator’s input signal range and optional auxiliary switches of the actuator are adjusted automatically to the stroke of the valve.

The actuator automatically provides a consistent running time regardless of the valve stroke.

On power loss, the mechanical spring return mechanism drives the motor in turn, generating power to the board to control the spring return braking speed, avoiding mechanical stress and system water hammer. All actuators can be configured for either a 3-wire floating signal or various modulating control signals including sequencing.



Specifications

M900ARx M900AEx	Stem up (retract) Stem down (extend)
Voltage Supply	24 Vac ±10% 50-60Hz
Power Consumption	
Running	30 VA (21 W)
Rest	7 W
Running Time	
Modulating	20 sec.
Floating	60/300 sec. (selectable)
Spring Return	18 sec.
Transformer Sizing	50 VA
Stroke Range	0.35 in...1.2 in (9...30 mm)
Factory Set	.08 in (20 mm)
Force, nominal	202 Lbf (900N)
Duty Cycle	20%/60 minutes (full load, high amb.) 80%/60 minutes (half load, room temp.)
Analog input Voltage	0...10 Vdc (factory)
Selectable Range Vdc	2...10, 0...5, 2...6, 5...10, 6...10 4...20 Ma, with a 500 ohm resistor (included)
Position Feedback	2...10 Vdc or 0...5 Vdc (0...100%) 2 mA
Load	
Electrical Terminals	18 gauge

Environmental Storage	
Ambient Humidity Range	-13...149 °F (-25...65 °C) max. 95% non-condensing
Min. Ambient Temp.	14 °F (-10 °C)
Operating Max. Temp.	
122 °F (50 °C)	
113 °F (45 °C)	
107 °F (42 °C)	
100 °F (38 °C)	
90 °F (32 °C)	
	Chilled water applications
	at 281 °F (138°C) Fluid temp.
	at 300 °F (149 °C) Fluid temp.
	at 340 °F (171°C) Fluid temp.
	at 366 °F (186 °C) Fluid temp.
Enclosure Rating	
M900ARW, M900AEW	NEMA 4 (IP65)
M900AR, M900AE	NEMA 2 (IP54)
Sound Power Level	43 dBa
Materials	Aluminum
Conduit Connection	North American 1/2 in conduit connectors, two on the side, two on the bottom
S2 Auxillary Switch Relays (optional)	SPDT, 24Vac 4A resistive (contacts made at 5% and 95% of end stroke)

SpaceLogic M900A Series Spring Return Actuators

Weight Short Yoke Tall Yoke	6.9 lb (3.1 kg) 7.1 lb (3.2 kg)
Agency Listings Environmental	UL873, cULus, RCM, CE RoHS, REACH

Accessories

Part No.	Description	Required
AV-821	VB-7xxx series globe valve linkage kit	To mount the Tall U-Bolt M900A to VB-7xxx, order separately. F-27701
AV-822	VB-8xxx and VB-9313 Series 2-1/2 to 4" globe valve linkage kit	To mount the Tall U-Bolt M900A to VB-8xxx and VB-9313, order separately. F-27702
880 0104 000	S2 auxiliary end point switches	Optional Switches can be added to the standard models in the field

Available Products

Part Number	Spring Return	Tall U-Bolt Style ¹	Short Screw Mount Style ²	NEMA 4 Enclosure Rating	Auxiliary Switches
M900AR	Retract	X			0
M900AE	Extend	X			0
M900AR-VB	Retract		X		0
M900ARW	Retract	X		X	0
M900ARW-VB	Retract		X	X	0
M900ARW-S2	Retract	X		X	2-SPDT
M900AEW-S2	Extend	X		X	2-SPDT

¹ - VB-7xxx (1/2" to 2") and required AV-821, VB-8xxx (2-1/2" to 4") and required AV-822, and VB-9xxx (2-1/2" to 3") and required AV-822.*

² - For Direct VB-7xxx Mounting (No Linkage Required)

* Sold separately.

Dimensions

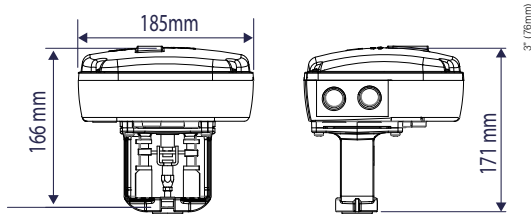

Dimensions for M900AR-VB and M900ARW-VB.

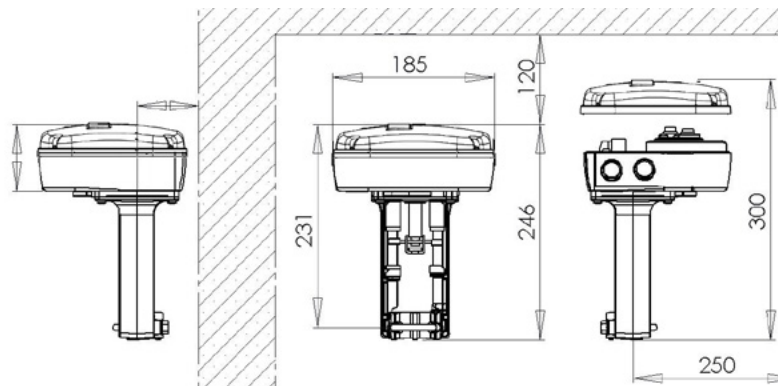

Dimensions for M900AR, M900AE, M900ARW, M900ARW-S2 and M900AEW-S2

MK-6811/6911 SR Pneumatic Actuators

MK-6811, MK-6911 Actuator Specifications

Inputs	
Control signal	5 to 10 psig (34 to 69 kPa). Positive Positioner start point adjustable 1 to 12 psi (7 to 83 kPa). Positive Positioner span adjustable 2 to 13 psi (14 to 89 kPa)
Supply pressure	15 to 20 psig (103 to 137 kPa) nominal 30 psig (205 kPa) maximum
Air connections	1/8 in FNPT
Effective area	50 sq. in. (323 cm ²)
Outputs	
MK-6811	1" (25 mm) Nominal stroke
MK-6911	1¾" (45 mm) Nominal stroke
Environment	
Temperature limits	Shipping / storage: -40 to 220°F (-40 to 104°C) ambient. Operating: -20°F to 220°F (-29°C to 104°C). Maximum allowable ambient: 220°F (104°C) at maximum valve Fluid temperature of 281°F (138°C). Minimum allowable valve Fluid temperature: 20°F (-7°C).
Positive Positioner	AK-42309-500 recommended for 5" valve, required for 6" valve, order separately. Supplied as standard on VK4 factory valve assemblies.

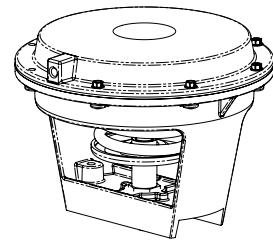

MK-6811

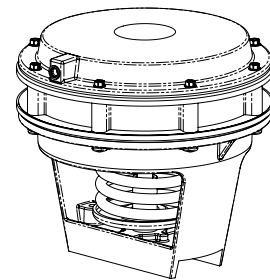

MK-6911

More information:
Scan the QR code or visit the link below.



Visit:
<http://goo.gl/6OaOs6>

MK-88/8911 SR Pneumatic Actuators

Application

MK-8800 series actuators are used to control 2½" to 4" VB-9000 series valves. MK-8900 series actuators are used to control 5" and 6" VB-9000 series valves.

MK-88/8900 Actuator Specifications

Effective Area	100 sq. in. (645 cm ²)
Construction	Housing: Die cast aluminum. Diaphragms: Replaceable beaded molded neoprene.
Stroke	See table below.
Spring	Retracts actuator shaft and raises valve stem on loss of air pressure.
Nominal range	See table below.
Starting point	Adjustable ± 1 psi (7 kPa). Maximum air pressure: 30 psig (207 kPa).
Ambient temperature limits	Shipping: -40 to 220°F (-40 to 104°C). Operating: -20 to 220°F (-29 to 104°C).
Air connection	1/8" FNPT
Valve stroke position indication	1/8" (3 mm) increments
Mounting	In any upright position with actuator head above 45° of the center line of the valve body. Actuator head may be swiveled to any convenient position.
Dimensions	See table below.
Optional accessories	
Linkage	AV-496
AK-52309-500	Positive Positioner with linkage
Tool-95	Pneumatic calibration tool kit

Specifications

Part number	Nominal spring range ^a		Nominal stroke		Dimensions		For use with valve bodies
	psig	kPa	in.	mm	in.	mm	
MK-8811	5-10	34-69	1	25.4	11¼ high x 10½ wide x 10½ deep	298 high x 267 wide x 267 deep	VB-9313 2½ – 4"
MK-8911			2	50.8	12¼ high x 10½ wide x 10½ deep	324 high x 267 wide x 267 deep	VB-9313 5 & 6"

a - Nominal (no load) spring ranges are based on maximum 1" (25.4 mm) or 2" (50.8 mm) stroke.



MK-8xxx
Series Actuator
with 3-Way Valve Assembly

Pneumatic Positive Positioning Relay for VB-7/8/9xxx

Positive Positioning Relay

Positive Positioner Pneumatic Relay is used to accurately position an actuator stroke with respect to signal pressure from the controller. It can also be used to change the effective spring range of an actuator and increase the capacity of a controller.

Features

For accurate positioning of valve and damper actuators, this positioner utilizes a pilot-operated, relay-type position-sensing mechanism, much more sensitive to actuator position changes than some competitive “force-balance” positioners.

Model Number	Description
AK-42309-500	Positive Positioning Relay with Mounting Linkage.

Note: This model cannot be used with M556, M572, M573, M574, and MK-12000 Series actuators. Use N800-0555 positioner with M556, M573, and M574.

Specifications

Action	Direct (increase in output pressure to actuator with an increase in pilot pressure from controller)
Pilot input	0 to main air pressure, psig.
Output	0 to main air pressure, psig.
Construction	
Housing	Polysulfone
Diaphragm	Neoprene
Start point	Adjustable 1 to 12 psig (7 to 83 kPa).
Span	Adjustable 2 to 13 psi (14 to 90 kPa); factory set: 5 psig
Stroke	Adjustable 2 to 13 psi (14 to 90 kPa); factory set: 5 psig with feedback spring for 7/16 to 5" stroke
Supply air pressure	Clean, oil free, dry air required (refer to EN-123)
Maximum	30 psig (207 kPa)
Nominal supply	15 to 20 psig (103 to 138 kPa)
Environment	
Ambient temperature limits	Shipping: -40 to 160°F (-40 to 71°C). Operating: 32 to 140°F (0 to 60°C)
Humidity	5 to 95% R.H., non-condensing
Locations	NEMA Type 1 (IP10)
Air connections	
“M” and “B”	Barbed for 1/4" O.D. plastic tubing
“P”	Dual-contoured for 1/4" O.D. and 5/32" O.D. tubing
Air consumption (air compressor sizing)	19 scim(5.2 mL/s) at 20 psig (138 kPa) supply
Air capacity for sizing air mains	20 scim (5.5 mL/s)
Flow capacity	860 scim (235 mL/s) at 20 psig (138 kPa) supply
Mounting linkage	All necessary linkage provided to assemble AK-42309-500 to the following actuator series; MK-6600, MK-6800, MK-6900, MK-8800 and MK-8900
Dimensions	2½ H x 4½ W x 3 D" (64 x 114 x 76 mm)

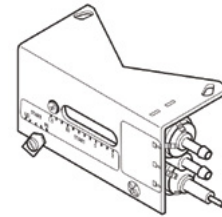

More information:
Scan the QR code or visit the link below.



Visit:
<http://goo.gl/LJCLEb>

Rack & Pinion Linkages AV-607/609-1

Application

The AV-607-1 and AV-609-1 linkages are designed to link single or dual Schneider Electric SmartX spring return and non-spring return actuators to 1½" to 6" VB-9313 and 2½" to 6" VB-8xx3 globe valves.

Features

- Allows mounting of single or dual actuators Schneider Electric SmartX actuators
- AV-607-1 is compatible with Schneider Electric (e.g., Siebe, Barber-Colman, INVENSYS) 2½" to 5" VB-8xx3, 2½" to 4" VB-9313 and discontinued 2" to 4" VB-9xxx valves and Schneider Electric SmartX actuators 2
- AV-609-1 is compatible with Schneider Electric (e.g., Siebe, Barber-Colman, INVENSYS) 6" VB-8xx3, 5" to 6" VB-9313 and 5" and 6" VB-92xx valves and Schneider Electric SmartX actuators 2
- Maintenance-free construction
- Corrosion protected heavy-duty steel rack-and-pinion construction and metal housing
- Precision rack self aligns with the valve stem
- 2 - Check the appropriate valve selection guide for close-offs for your application. AV-607-1 and AV-609-1 replace AV-607 and AV-609 respectively

Applicable Literature

- EN-205 Water System Guidelines, F-26080
- AV-608 Linkage Adapter Kit installation instructions, F-27253
- AV-607-1, 609-1 SmartX Actuator Linkages for 2½" to 6" Globe Valves
- MA40-704x, MA4x-707x, MA4x-715x SmartX Series Spring Return Two-position Actuators Installation Instructions, F-26642
- MA40-717x SmartX Series Spring Return Two-position Actuators Installation Instructions, F-26742
- MF4x-7xx3 SmartX Series Spring Return Floating Actuator Installation Instructions, F-26644
- MF40-7173 SmartX Series Spring Return Floating Actuator installation instructions, F-26749
- MF41-6153,/MS41-6153 Series Non-Spring Return Rotary Electronic Damper Actuator Installation Instructions, F-27215
- MS4x-7xx3 SmartX Series Spring Return Proportional Actuator Installation Instructions, F-26645
- MS40-717x SmartX Series Spring Return Proportional Actuator Installation Instructions, F-26748
- Vx-7000 Series and Vx-9000 Series Mx4x-6xxx and Mx4x-7000 Series Linked Globe Valve Assemblies with SmartX Actuators Selection Guide, F-26752
- VB-8xx3 Series Balanced Plug Valve Selection Guide, F-27199

Note: Do not install a 300 lb-in Mx41-634-x actuator on the AV-607-1 linkage as equipment damage may occur.

Linkage Kits and Actuator/Linkage Assemblies

Application	Actuator	Linkage Kita
2½" to 5" 2-Way and 3-Way	MK-6811 ^b	AV-497 (VB-8000 only) AV-495 (VB-9313 up to 4" only)
6" 2-Way and 3-Way	MK-6911 ^b	AV-497 (VB-8000 only)
2½" to 4" 3-Way	MK-8811	AV-496 (VB-9313 only)
5" to 6" 3-Way	MK-8911	AV-496 (VB-9313 only)
2½" to 5" 2-Way and 3-Way (1" Nominal stroke)	MA41-7150,51,53, MA40-7170,71,73, MF41-6343a, MF41-7153, MF40-7173, MS41-6340a, MS41-6343a, MS41-7153, MS40-7170,71,73	AV-607-1 ^c
6" 2-Way and 3-Way (1¾" Nominal stroke)		AV-609-1 ^d
2½" to 6" 2-Way and 3-Way (1" Nominal stroke)	M1500A	AV-822

a - Mx61-720x Actuators require no separate linkage. Mx41-634x is not compatible with AV-607-1. The AV-609-1 linkage can be used with the Mx41-634x actuator on 2½" to 5" VB-8000 valves or 2½" to 4" VB-9313 valves, but the valve will stroke over a shorter portion of the control input signal.

b - AK-42309-500 (order separately) optional for 2½" to 5" valve, required for 6" valve. VK4 valve assemblies include Positive Positioner.

c - 2½" to 5" VB-8000 valves or 2½" to 4" VB-9313 valves.

d - 6" VB-8000 valves or 5" to 6" VB-9313 valves.

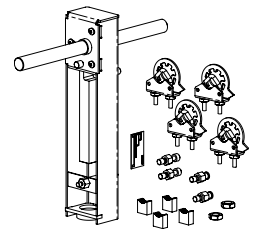

AV-607-1

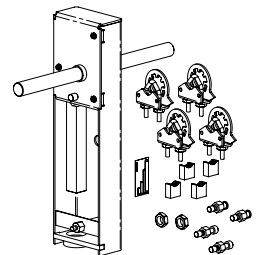

AV-609-1

Butterfly Valves and Actuators

SpaceLogic Butterfly Valves and Actuators offer a wide range of two and three-way sizes, along with electric SR and NSR actuator models that operate with on/off, floating, or proportional control signals.

All assemblies include industry-leading valve features such as stainless-steel double "D" shafts, a nylon 11-coated ductile iron or SS disc to provide bubble-tight shutoff, minimum torque, and longer seat life. Designed to meet NEMA 2 and NEMA 4 or IP 65 specifications, the actuators have an easy-to-operate override that works with a manual override hand-wheel system.



Butterfly Valves and Actuators

Butterfly Valve Assembly Overview and Ordering

Product Description

Schneider Electric's Butterfly Valve line offers a wide range of 2-Way and 3-Way sizes, along with electric non-spring return and spring return actuator models that operate with on/off, floating, or proportional control signals. Models include standard resiliency valve bodies for 2 and 3-Way applications and high performance valve bodies for 2-Way applications that require larger close offs and wider temperature ranges.

All standard resiliency assemblies include industry leading butterfly valve features, stainless steel double "D" shafts, a nylon 11 coated ductile iron disc machined to provide Class VI (bubble-tight equivalent) shutoff, minimum torque, and a longer seat life.

Schneider Electric's High Performance Butterfly Valves are ideally suited to both high pressure, high temperature, high cycle and mission critical HVAC applications. This includes chiller isolation, cooling tower isolation, change-over systems, large air handler coil control, bypass and process control applications. With ANSI Class 150 rating, all valves are tested for bubble tight close-off to API 598 standards at maximum rated differential pressure.

Applications

Typical applications include data centers, cooling towers, central system shutoff and bypass piping control, thermal storage, and chiller and boiler control.

Features

Standard Valves

- 2 to 20" 2-Way assemblies and 2 to 16" 3-Way assemblies.
- Chilled/hot water/glycol applications.
- Molded in seat: Tightly controlled vulcanization process produces accurate and repeatable dimensions, which leads to consistently lower torque over the valve's lifetime.
- Upper and Lower Stem Bearing: Reduce operating torque and increase reliability in high cycle applications.
- End of Service Rated: Sealing at full rated differential pressure.
- Precision Engineered Profiled Disc Sealing Edge: Extends the valve life by reducing seat wear.
- Stainless Steel Double D Stem: Requires no pins or screws to connect the disc and stem.
- Extended neck design for temperature isolation and ease of insulation installation.
- Nylon 11 coated ductile iron and stainless steel disc.
- Reduced torque requirements.
- High purity peroxide cured EPDM seats.
- Low torque and superior rubber stability over the shelf life and service life of the valve.
- Wide choice of electric actuators and control signals.
- Cast iron lug bodies made with ANSI Class 125/150 flanges.
- Bubble-tight shut-off and bidirectional flow.
- NSF-61 certified.

High Performance Valves

- Double Offset Stem/Disc Design: Reduced seat wear, zero leakage, and low torque.
- Blowout Proof Stem: Safety and ease of use.
- Energized RTFE Seat: Zero leakage, self-adjusting for wear and easy field replacement.
- Pressure assisted, no pressure dependent seat design.
- Optimal performance and sealing at high or low differential pressures.
- Adjustable PTFE Packing: Packing can be adjusted while the valve is in service.
- Dead End Rating Equal to Nominal Pressure Rating: Allows the control valve to function as an isolation valve.



Part Numbering System

Specify fields for the Butterfly Valve assembly part number.

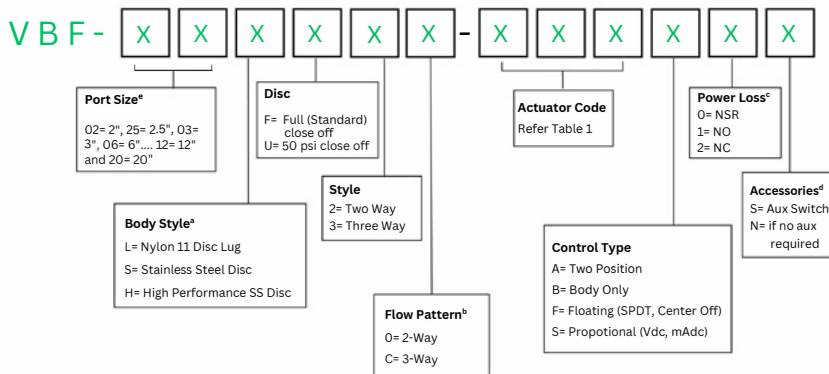

a. L = Standard Offer.

S = Optional Stainless Steel Disc. Currently available from 2"-20", 2-way, 175/150 psi (close off) with E1x - E9x actuators in 120 Vac only. Please reach out to your Schneider Electric representative for more information.

H= High Performance models 2.5"-18" 2-Way only (refer to the section for specific information on High Performance valve series).

b. 3 Way valves are configurable during the order process. When placing an order manually through Customer Care please note the Configuration Number as per the table and when ordering online through iPortal, please select the proper configuration from the drop-downs on the Cart Page.

c. Choose NO/NC while selecting S56/D56 actuators. Available up to 4", 50 psi close off.

d. Accessories: Actuators code E1x to E9x has aux switch as standard offer. Please select S when selecting E1x - E9x actuators. Refer to Table 1 for more information.

e. Size availability depends on the style (e.g., 2 way up to 20", 3 way up to 16").

Butterfly Valves and Actuators

Valve Size and Actuators Code Selection Chart

Table 1: 2-Way and 3-Way Valve Assemblies and Actuators

Refer to the part numbering system illustration.

2-Way Butterfly Valve Assemblies								3-Way Butterfly Valve Assemblies					
Size (inches)	Close Off Pressure (PSI)	SmartX SR	Direct Coupled NSR	NEMA 4 NSR 120 Vac		NEMA 4 NSR 24 Vac		SmartX SR	Direct Coupled NSR	NEMA 4 NSR 120 Vac		NEMA 4 NSR 24 Vac	
				On/Off 2 Position	Modulating	On/Off 2 Position	Modulating			On/Off 2 Position	Modulating	On/Off 2 Position	Modulating
2"	175	S56	E24	E10	E12	F10	F12	S56	E24	E10	E12	F10	F12
2.5"	175	S56	E24	E10	E12	F10	F12	D56	E25	E10	E12	F10	F12
	285			E10	E12	F10	F12						
3"	175	D56	E25	E10	E12	F10	F12	D56	E25	E10	E12	F10	F12
	285			E10	E12	F10	F12						
4"	50	D56	E25	E10	E12	F10	F12	D56	E25	E10	E12	F10	F12
	175		E26	E10	E12	F10	F12						
	285			E20	E22	F20	F22						
	50		E25	E10	E12	F10	F12		E26	E10	E12	F10	F12
5"	175			E10	E12	F10	F12			E20	E22	F20	F22
	285			E30	E32	F40	F42						
6"	50		E26	E10	E12	F10	F12		E26	E20	E22	F20	F22
	175			E20	E22	F20	F22			E20	E22	F20	F22
	285			E30	E32	F40	F42						
	50			E30	E32	F40	F42			E30	E32	F40	F42
8"	175			E30	E32	F40	F42			E40	E42	F40	F42
	285			E40	E42	F40	F42						
10"	50			E30	E32	F40	F42			E40	E42	F40	F42
	175			E40	E42	F40	F42			E50	E52	F60	F62
	285			E50	E52	F60	F62						
	50			E40	E42	F40	F42			E40	E42	F40	F42
12"	175			E50	E52	F60	F62			E60	E62	F60	F62
	285			E60	E62	F60	F62						
14"	50			E60	E62	F60	F62			E60	E62	F60	F62
	150			E60	E62	F60	F62			E70	E72		
	285			E70	E72								
	50			E60	E62	F60	F62			E70	E72		
16"	150			E70	E72					E80	E82		
	285			E80	E82								
18"	50			E70	E72					E80	E82		
	150			E80	E82					E90	E92		
	285			E90	E92								
	50			E80	E82					E90	E92		
20"	150			E90	E92								
	200			E90	E92								

SR = Spring return actuator available as configured for normally open and normally closed butterfly valves.

NSR = Non-spring return actuator.

E1x, E2x, E4x and E6x available as 24 Vac powered: change actuator code E to F and 120 to 24. e.g., E20 to F20, then "S70-24-0081-H"

120 Vac only: E3x, E5x, E7x, E8x, E9x.

D56 = Dual Actuator.

S56 = Single Actuator.

Butterfly Valve Actuators & Assembly Ordering

Table 2: Actuator Codes and Part Numbers

Refer to the part numbering system illustration on the previous page.

Actuator Code ^a	On/Off or Floating SR	Actuator Code ^a	Modulating (2–10 Vdc, 4–20mA) SR with the addition of a 500 ohm resistor
S56	MA41-7153 (On/Off)	S56	MS41-7153
D56	2 MA41-7153 (On/Off)	D56	2 x MS41-7153 (Modulating)
S56	MF41-7153 (Floating)	–	–
D56	2 MF41-7153 (Floating)		
Actuator Code ^a	On/Off or Floating SR with Two SPDT Auxiliary Switches	Actuator Code ^a	Modulating (2–10 Vdc, 4–20 mA) SR with the addition of a 500 ohm resistor with Two Auxiliary Switches
S56	1 MA41-7153-502 (On/Off)	S56	MS41-7153-502 (Modulated)
D56	1 MA41-7153 & 1 MA41-7153-502 (On/Off)	D56	1 MS41-7153 & 1 MS41-7153-502 (Modulated)
S56	1 MF41-7153-502 (Floating)	–	–
D56	1 MF41-7153 & 1 MF41-7153-502 (Floating)		
Actuator Code ^a	On/Off or Floating NSR	Actuator Code ^a	Modulating (0–10 Vdc, 4–20 mA) NSR
E24	NR-2216-521	E24	NR-2216-541
E25	NR-2224-521	E25	NR-2224-541
E26	2 x NR-2224-521	E26	2 x NR-2224-541
Actuator Code ^a	On/Off or Floating NSR with Two SPDT Auxiliary Switches	Actuator Code ^a	Modulating (0–10 Vdc, 4–20 mA) NSR with Two SPDT Auxiliary Switches
E24	NR-2216-522	E24	NR-2216-542
E25	NR-2224-522	E25	NR-2224-542
E26	1 NR-2224-521 & 1 NR-2224-522	E26	1 NR-2224-541 & 1 NR-2224-542
Actuator Code ^b	On/Off NSR with Two SPDT Auxiliary Switches and Heater ^c	Actuator Code ^b	Modulating (0–10 Vdc, 4–20 mA) NSR with Two SPDT Auxiliary Switches and Heaters
E10	S71-120-0530-H	E12	S71-120-0530-SV
E20	S70-120-0081-H	E22	S70-120-0081-SV
E30 (120Vac only)	S70-120-0121-H	E32 (120 vac only)	S70-120-0121-SV
E40	S70-120-0201-H	E42	S70-120-0201-SV
E50 (120 Vac only)	S70-120-E301-H	E52 (120 Vac only)	S70-120-E301-SV
E60 (120 Vac only)	S70-120-0501-H	E62	S70-120-0501-SV
E70 (120 Vac only)	S70-120-0651-H	E72 (120 Vac only)	S70-120-0651-SV
E80 (120 Vac only)	S70-120-1300-H	E82 (120 Vac only)	S70-120-1300-SV
E90 (120 Vac only)	S70-120-1800-H	E92 (120 Vac only)	S70-120-1800-SV

a. S = Single actuators, D = Dual actuators

b. Change actuator code "E" to "F" for 24 Vac, e.g., E20 to F20, then "S70-24-0081-H"

Table 3: Actuator Types and Features

Actuator Family	Spring Return	Available Input Signals	Available Options
SmartX SR MX41-7153	Yes	24 Vac, Two Position, Floating, 2–10 Vdc, 4–20 mA with the addition of a 500 ohm resistor, Proportional	Auxiliary Switch
Direct Coupled NSR NR-22xx	No	24 Vac, Three Wire Two Position, Floating, 0–10 Vdc, 4–20 mA, Proportional	Auxiliary Switch
NEMA 4 with Hand Wheel NSR-S70-xxx-	No	120 Vac. or 24 Vac. Three Wire Two Position, Floating, 0–10 Vdc, 4–20 mA, Proportional	Auxiliary Switch and Heater included

Butterfly Valves and Actuators

SmartX SR Actuators for 2" to 4" 2 and 3-Way Valves

Specifications	
Actuator code	S56, D56 (Mx41-7153 Series)
Power Loss Mode	Spring return
Control Signal	On/off, floating, or proportional 2 to 10 VDC, 4 to 20 mA with the addition of a 500 ohm resistor
Power Requirements	24 Vac \pm 20%, 22 to 30 VDC, 9.7VA.
Environment	NEMA 2
Ambient Temperatures	-22 to 140 °F (-12 to 60°C)
Agency Listings	UL, CUL, CE
Manual Operator	Provided on single mount units
Option	Auxiliary switches 7 A @250 Vac
Agency Listings	UL, CUL, CE



SmartX Spring Return
Mx41-7153 Actuator



Table 4: SmartX SR Actuators for 2"...4" 2 and 3-Way Valves

Model number	Actuator code	Power	Input signal	Feedback	Power loss mode	Optional accessories
MA41-7153	S56 or D56 ^b	24 Vac	On/Off	-	SR	Two SPDT Auxiliary switches ^a
MF41-7153			Floating			
MS41-7153			2 to 10 VDC	2 to 10 VDC		
MA41-7153-502			On/Off	-		
MF41-7153-502			Floating			
MS41-7153-502			2 to 10 VDC	2 to 10 VDC		

a. Note: Models with D56 Actuator code that require the auxiliary switch option will ship with one actuator without switches and one actuator with auxiliary switches.

b. D56 = Dual actuators.

c. SR = Spring Return.

NR-22xx NSR Actuators for 2" to 6" 2 and 3-Way Valves

Specifications	
Actuator code	E24, E25, E26 (NR-2000 Series)
Power Loss Mode	NSR
Control Signal	On/off, floating, or 2 to 10 VDC, 4 to 20 mA.
Power Requirements	20 to 30 Vac, 24 VDC \pm 10% NR-2216 6.5VA, NR-2224 7.5VA
Environment	NEMA 2
Ambient Temperatures	-4 to 122 °F (-2 to 50°C)
Agency Listings	UL, CSA, CE
Optional Auxiliary Switch	2 SPDT 24 Vac 1.5 A inductive, 3 A resistive, 35 VA per switch
Manual Operator	Provided on all models



Non-Spring Return
NR-22xx-5xx Actuator

Table 5: NR-22xx NSR Actuators for 2"...6" 2 and 3-Way Valves

Model number	Actuator code	Power	Input signal	Feedback	Power loss mode	Optional accessories
NR-2216-521	E24	24 Vac	On/off, floating	-	NSR	-
NR-2216-522			0 to 10 VDC, 4 to 20 mA			0 to 10 VDC
NR-2216-541			On/off, floating	-		-
NR-2216-542			0 to 10 VDC, 4 to 20 mA			0 to 10 VDC
NR-2224-521	E25 or E26	24 Vac	On/off, floating	-	NSR	-
NR-2224-522			0 to 10 VDC, 4 to 20 mA			0 to 10 VDC
NR-2224-541			On/off, floating	-		-
NR-2224-542			0 to 10 VDC, 4 to 20 mA			0 to 10 VDC

a - Optional. Note: Models with E26 Actuator code that require the auxiliary switch option will ship with one actuator without switches and one actuator with auxiliary switches.

E26= Dual actuator

NSR = Non-Spring Return.

Butterfly Valves and Actuators

S70 and S71 NSR Actuators for 2"...20" 2-Way & 2"...16" 3-Way Valves*

* S70 and S71 actuators are not sold separately and are available only as part of complete butterfly valve assemblies.

Specifications	
Actuator Code	71 and 70 Series
Power Loss Mode	Non-spring return
Control Signal	-40 to 500°F
Actuator Code	Ex0 (120 Vac) or Fx0 (24 Vac) On/off, floating
	Ex2 (120 Vac) or Fx2 (24 Vac)
Factory configured for	4...20 mA with a 250 W
Input Impedance, field configurable for	0...10 Vdc or 2...10 Vdc
Power Requirements	120 Vac or 24 Vac, 50/60 Hz
E1x/F1x, E2x/F2x	1.5 ^a
E3x, E4x/F4x, E5x	2.1 ^a
E6x/F6x, E7x, E8x, E9x	3.1 ^a
Environment	NEMA 4
Ambient Temperatures	-40...150°F (-40...60°C)
Regulatory Compliance	c-UL-us LISTED mark and CE mark
Standard Auxiliary Switch	(Included) 10 A resistive at 125/250 Vac 1/2 A at 125 Vdc
Heater	15W
Manual Operator with Disconnect	Declutchable hand wheel
Agency Listings	UL, CSA, CE

Note: 24 Vac (Fxx) models are Half Wave devices, see F-26363



Non-Spring Return
S70-xxxx Actuator

Table 6: NSR Actuators NEMA 4 for 2"...20" 2-Way and 2"...16" 3-Way Valves*

* S70 and S71 actuators are available only factory-mounted on butterfly valve assemblies and are not sold separately.

Model Number	Actuator Code	Power ^a	Input Signal	Feedback	Power Loss Mode	Optional Accessories
S71-120-0530-H	E10	E=120 Vac F=24 Vac	On/off, floating	-	NSR	Two SPDT Auxiliary Switches and Heater (standard)
S70-120-0081-H	E20					
S70-120-0121-H	E30 (120 Vac only)					
S70-120-0201-H	E40					
S70-120-E301-H	E50 (120 Vac only)					
S70-120-0501-H	E60					
S70-120-0651-H	E70 (120 Vac Only)					
S70-120-1300-H	E80 (120 Vac Only)					
S70-120-1800-H	E90 (120 Vac Only)					

Model Number	Actuator Code	Power ^a	Input Signal	Feedback	Power Loss Mode	Optional Accessories
S71-120-0530-SV	E12	E=120 Vac F=24 Vac	0...10 Vdc, 4...20 mA	0...10 Vdc, 4...20 mA	NSR	Two SPDT Auxiliary Switches and Heater (standard)
S70-120-0081-SV	E22					
S70-120-0121-SV	E32 (120 Vac only)					
S70-120-0201-SV	E42					
S70-120-E301-SV	E52 (120 Vac only)					
S70-120-0501-SV	E62					
S70-120-0651-SV	E72 (120 Vac Only)					
S70-120-1300-SVH	E82 (120 Vac Only)					
S70-120-1800-SVH	E92 (120 Vac Only)					

For 24 Vac valve assemblies, use code F in place of E in the numbering table. E10 becomes F10 for 24 Vac powered. (F10 actuator code=S71-24-0530-H).

2-Way Valve Assemblies

2-Way Butterfly Valve Assemblies (2" ...4") with NEMA 2 SR, NO and NC Actuators

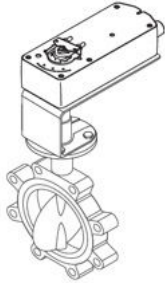

Flow Type	Equal % bidirectional	
Body	Polyester coated cast iron, ASTM A126 Class B lug, Mates with ANSI 125/150 flanges.	
Seat	EPDM	
Material	Stem	Stainless steel double D stem
	Stem Seals	Self adjusting double U cup
	Disc	Ductile iron nylon 11 coated disc
Fluid Temperatures	-40...250°F (-40...121°C)	
Close-Off Rating	ANSI VI Bubble tight	
Application	Chilled or hot water up to 60% glycol	

Table 7: 2-Way 2"...4" Valve Assemblies with NEMA 2 SR SmartX Actuators

On/Off	Floating	Proportional	Voltage (Vac)	Valve size (inches)	Close Off Pressure PSI (kPa)	CV (Kvs) @ 90°
VBF-02LF20-S56AXY	VBF-02LF20-S56FX Y	VBF-02LF20-S56SXY	24 Vac	2"	175	87
VBF-25LF20-S56AXY	VBF-25LF20-S56FX Y	VBF-25LF20-S56SXY		2.5"	175	185
VBF-03LF20-D56AXY	VBF-03LF20-D56FX Y	VBF-03LF20-D56SXY		3"	175	360
VBF-04LU20-D56AXY	VBF-04LU20-D56FX Y	VBF-04LU20-D56SXY		4"	50	740

Replace X with 1 for NO and 2 for NC versions.

Replace Y with N for no auxiliary and S for optional two SPDT auxiliary switch models.

2"...4" Valve Assembly Dimensions with SR Actuators

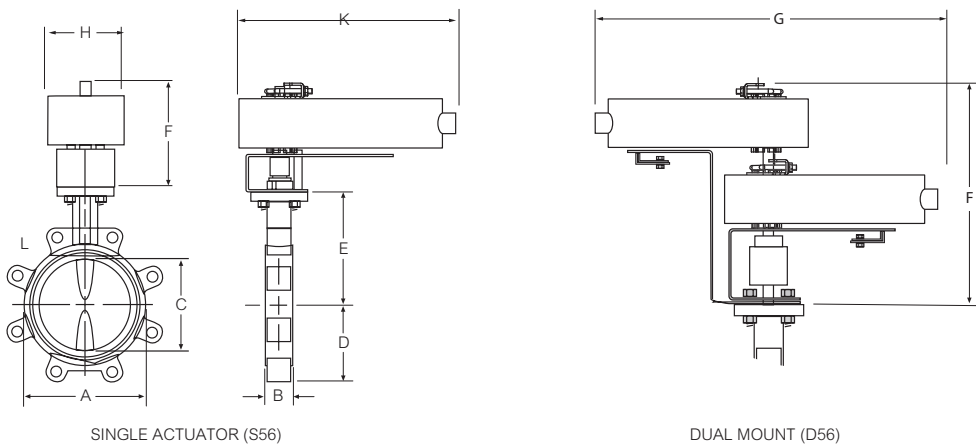

Table 8: 2-Way SR

Valve Assembly Part Number	Valve Size (in.)	Dimensions in inches (mm)									
		A	B	C	D	E	F	G	H	K	L
VBF-02LF20-S56AXY	2"	3.7 (94)	1.7 (43)	2.0 (51)	2.3 (58)	5.5 (140)	6.00 (152)	—	4.00 (102)	12.5 (318)	(4) - 5/8"-11
VBF-25LF20-S56AXY	2.5"	4.3 (106)	1.8 (46)	2.5 (64)	2.6 (65)	6.0 (152)	6.00 (152)	—	4.00 (102)	12.5 (318)	(4) - 5/8"-11
VBF-03LF20-D56AXY	3"	4.9 (124)	1.8 (46)	3.0 (76)	2.8 (71)	6.3 (159)	11.75 (298)	19.00 (483)	4.00 (102)	—	(4) - 5/8"-11
VBF-04LU20-D56AXY	4"	6.1 (154)	2.1 (52)	4.1 (103)	4.1 (104)	7.0 (178)	11.75 (298)	19.00 (483)	4.00 (102)	—	(8) - 5/8"-11

2-Way Butterfly Valve Assemblies (2" ...20") with NSR NEMA 4 Actuators



Flow Type	Equal % bidirectional	
Body	Polyester coated cast iron, ASTM A126 Class B lug, Mates with ANSI 125/150 flanges	
Seat	EPDM	
Material	Stem	Stainless steel double D stem
	Stem Seals	Self adjusting double U cup
	Disc	Ductile iron nylon 11 coated or Stainless steel disc
Fluid Temperatures	-40...250°F (-40...121°C)	
Close-Off Rating	ANSI VI Bubble tight	
Application	Chilled or hot water up to 60% glycol	

Table 11: 2-Way Nylon 11 Disc Butterfly Valve Assemblies with NSR NEMA4 Actuator, Hand Wheel with Two SPDT Auxiliary Switches and Heater

Model Number		Power	Valve Size (inches)	Close Off Pressure (PSI)	CVs @90°
On/Off	Modulating				
VBF-04LU20-F10A0S	VBF-04LU20-F12S0S	24 Vac	4"	50	740
VBF-05LU20-F10A0S	VBF-05LU20-F12S0S		5"	50	1218
VBF-06LU20-F10A0S	VBF-06LU20-F12S0S		6"	50	1900
VBF-08LU20-F40A0S	VBF-08LU20-F42S0S		8"	50	3765
VBF-10LU20-F40A0S	VBF-10LU20-F42S0S		10"	50	6661
VBF-12LU20-F40A0S	VBF-12LU20-F42S0S		12"	50	10066
VBF-14LU20-F60A0S	VBF-14LU20-F62S0S		14"	50	11598
VBF-16LU20-F60A0S	VBF-16LU20-F62S0S		16"	50	15395

Model Number		Power	Valve Size (inches)	Close Off Pressure (PSI)	CVs @90°
On/Off	Modulating				
VBF-04LU20-E10A0S	VBF-04LU20-E12S0S	120 Vac	4"	50	740
VBF-05LU20-E10A0S	VBF-05LU20-E12S0S		5"	50	1218
VBF-06LU20-E10A0S	VBF-06LU20-E12S0S		6"	50	1900
VBF-08LU20-E30A0S	VBF-08LU20-E32S0S		8"	50	3765
VBF-10LU20-E30A0S	VBF-10LU20-E32S0S		10"	50	6661
VBF-12LU20-E40A0S	VBF-12LU20-E42S0S		12"	50	10066
VBF-14LU20-E60A0S	VBF-14LU20-E62S0S		14"	50	11598
VBF-16LU20-E60A0S	VBF-16LU20-E62S0S		16"	50	15395
VBF-18LU20-E70A0S	VBF-18LU20-E72S0S		18"	50	20120
VBF-20LU20-E80A0S	VBF-20LU20-E82S0S		20"	50	25329

Butterfly Valves and Actuators

Model Number		Power	Valve Size (inches)	Close Off Pressure (PSI)	CVs @ 90°
On/Off	Modulating				
VBF-02LF20-F10A0S	VBF-02LF20-F12S0S	24 Vac	2"	175	87
VBF-25LF20-F10A0S	VBF-25LF20-F12S0S		2.5"	175	185
VBF-03LF20-F10A0S	VBF-03LF20-F12S0S		3"	175	360
VBF-04LF20-F10A0S	VBF-04LF20-F12S0S		4"	175	740
VBF-05LF20-F10A0S	VBF-05LF20-F12S0S		5"	175	1218
VBF-06LF20-F20A0S	VBF-06LF20-F22S0S		6"	175	1900
VBF-08LF20-F40A0S	VBF-08LF20-F42S0S		8"	175	3765
VBF-10LF20-F40A0S	VBF-10LF20-F42S0S		10"	175	6661
VBF-12LF20-F60A0S	VBF-12LF20-F62S0S		12"	175	10066
VBF-14LF20-F60A0S	VBF-14LF20-F62S0S		14"	150	11598

Model Number		Power	Valve Size (inches)	Close Off Pressure (PSI)	CVs @90°
On/Off	Modulating				
VBF-02LF20-E10A0S	VBF-02LF20-E12S0S	120 Vac	2"	175	87
VBF-25LF20-E10A0S	VBF-25LF20-E12S0S		2.5"	175	185
VBF-03LF20-E10A0S	VBF-03LF20-E12S0S		3"	175	360
VBF-04LF20-E10A0S	VBF-04LF20-E12S0S		4"	175	740
VBF-05LF20-E10A0S	VBF-05LF20-E12S0S		5"	175	1218
VBF-06LF20-E20A0S	VBF-06LF20-E22S0S		6"	175	1900
VBF-08LF20-E30A0S	VBF-08LF20-E32S0S		8"	175	3765
VBF-10LF20-E40A0S	VBF-10LF20-E42S0S		10"	175	6661
VBF-12LF20-E50A0S	VBF-12LF20-E52S0S		12"	175	10066
VBF-14LF20-E60A0S	VBF-14LF20-E62S0S		14"	150	11598
VBF-16LF20-E70A0S	VBF-16LF20-E72S0S		16"	150	15395
VBF-18LF20-E80A0S	VBF-18LF20-E82S0S		18"	150	20120
VBF-20LF20-E90A0S	VBF-20LF20-E92S0S		20"	150	25329

E3x, E5x, E7x, E8x and E9x only available in 120 Vac.

Table 11.1: 2-Way SS Disc Butterfly Valve Assemblies with NSR NEMA4 Actuator, Hand Wheel with Two SPDT Auxiliary Switches and Heater

Model Number		Power	Valve Size (Inches)	Close Off Pressure (PSI)	CVs @ 90°
On/Off	Modulating				
VBF-02SF20-E10A0S	VBF-02SF20-E12S0S	120Vac	2"	175	87
VBF-25SF20-E10A0S	VBF-25SF20-E12S0S		2.5"	175	185
VBF-03SF20-E10A0S	VBF-03SF20-E12S0S		3"	175	360
VBF-04SF20-E10A0S	VBF-04SF20-E12S0S		4"	175	740
VBF-05SF20-E10A0S	VBF-05SF20-E12S0S		5"	175	1218
VBF-06SF20-E20A0S	VBF-06SF20-E22S0S		6"	175	1900
VBF-08SF20-E40A0S	VBF-08SF20-E42S0S		8"	175	3765
VBF-10SF20-E40A0S	VBF-10SF20-E42S0S		10"	175	6661
VBF-12SF20-E50A0S	VBF-12SF20-E52S0S		12"	175	10066
VBF-14SF20-E60A0S	VBF-14SF20-E62S0S		14"	150	11598
VBF-16SF20-E80A0S	VBF-16SF20-E82A0S		16"	150	15395
VBF-18SF20-E80A0S	VBF-18SF20-E82A0S		18"	150	20120
VBF-20SF20-E90A0S	VBF-20SF20-E92A0S		20"	150	25329

2"...20" Valve Assembly Dimensions with NSR NEMA 4 Actuators

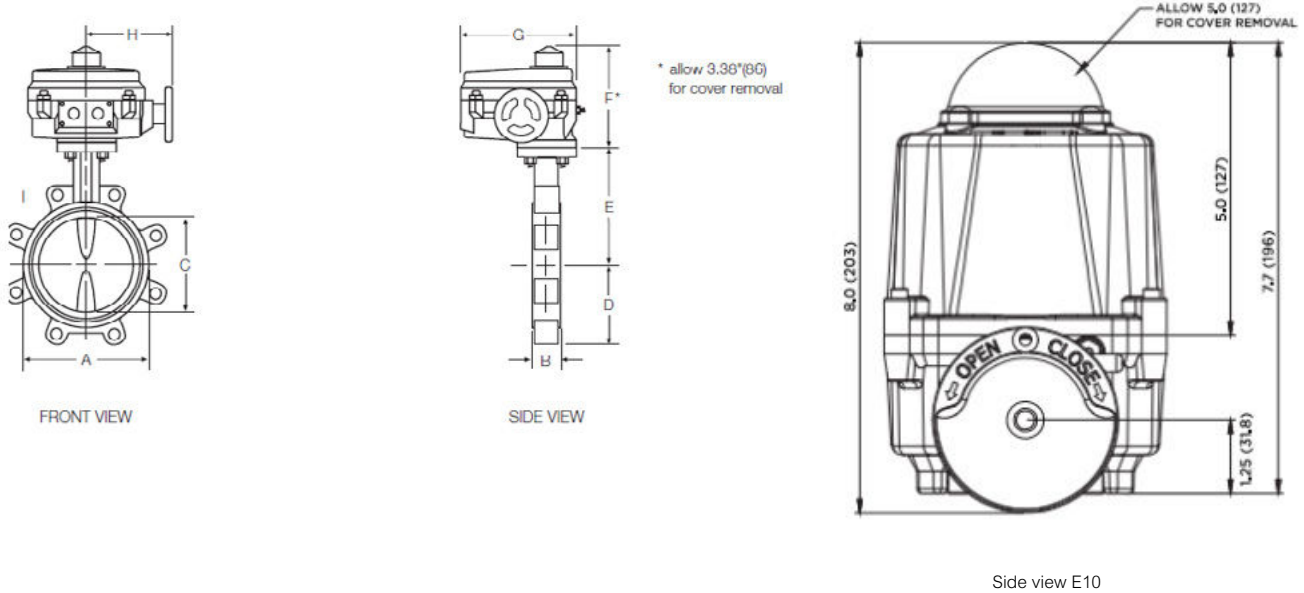
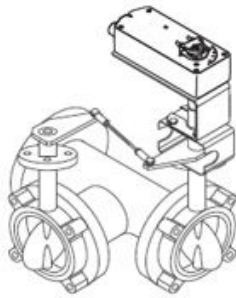

Table 12: 2"...20" 2-Way Butterfly Valve Assemblies with NSR NEMA 4 Actuator Dimensions

Valve Assembly Part Number	Valve Size (in.)	Dimensions in inches (millimetres)								
		A	B	C	D	E	F	G	H	L
VBF-02LF20-E10A0S	2"	3.7 (94)	1.7 (43)	2.0 (51)	2.3 (58)	5.5 (140)	7.7 (196)	8 (203)	-	(4) - 5/8"-11
VBF-25LF20-E10A0S	2.5"	4.3 (106)	1.8 (46)	2.5 (64)	2.6 (65)	6.0 (152)	7.7 (196)	8 (203)	-	(4) - 5/8"-11
VBF-03LF20-E10A0S	3"	4.9 (124)	1.8 (46)	3.0 (76)	2.8 (71)	6.3 (159)	7.7 (196)	8 (203)	-	(4) - 5/8"-11
VBF-04LF20-E10A0S	4"	6.1 (154)	2.1 (52)	4.1 (103)	4.1 (104)	7.0 (178)	7.7 (196)	8 (203)	-	(8) - 5/8"-11
VBF-05LF20-E10A0S	5"	7.1 (179)	2.2 (56)	5.0 (128)	4.6 (117)	7.5 (191)	7.7 (196)	8 (203)	-	(8) - 3/4"-10
VBF-06LF20-E20A0S	6"	8.1 (206)	2.2 (56)	5.8 (146)	5.1 (129)	8.0 (203)	6.96 (176)	7.5 (191)	5.8 (147)	(8) - 3/4"-10
VBF-08LF20-E30A0S	8"	10.5 (267)	2.4 (60)	7.8 (197)	6.1 (154)	9.5 (241)	7.96 (203)	10.1 (256)	7.8 (198)	(8) - 3/4"-10
VBF-10LF20-E40A0S	10"	12.6 (324)	2.7 (68)	9.8 (249)	7.7 (195)	10.8 (273)	7.96 (203)	10.1 (256)	7.8 (198)	(12) - 7/8"-9
VBF-12LF20-E50A0S	12"	14.9 (373)	3.1 (78)	11.8 (299)	9.0 (229)	12.3 (311)	7.96 (203)	10.1(256)	7.8 (198)	(12) - 7/8"-9
VBF-14LF20-E60A0S	14"	17.1 (433)	3.1 (78)	13.3 (337)	9.9 (252)	13.6 (346)	8.56 (218)	12.1 (308)	9.5 (241)	(12) - 1"-8
VBF-16LF20-E70A0S	16"	19.2 (488)	4.0 (102)	15.3 (387)	11.3 (287)	14.8 (375)	8.56 (218)	12.1 (308)	9.5 (241)	(16) - 1"-8
VBF-18LF20-E80A0S	18"	21.1 (536)	4.5 (114)	17.3 (438)	12.2 (309)	16.0 (406)	13.86 (351)	12.1 (308)	9.5 (241)	(16) - 1-1/8"-8
VBF-20LF20-E90A0S	20"	23.3 (591)	5.0 (127)	19.3 (489)	14.0 (356)	17.3 (438)	13.86 (351)	12.1 (308)	9.5 (241)	(20) -1"-1/8-8

3-Way Valve Assemblies

3-Way Butterfly Valve Assemblies (2"…4") with NEMA 2 SR, NO and NC Actuators



Flow Type	Equal % linear bidirectional Mixing or diverting configurations	
Body	Polyester coated cast iron, ASTM A126 Class B lug, Mates with ANSI 125/150 flanges.	
Seat	EPDM	
Material	Stem	Stainless steel double D stem
	Stem Seals	Self adjusting double U cup
	Disc	Ductile iron nylon 11 coated disc
Fluid Temperatures	-40...250°F (-40...121°C)	
Close-Off Rating	ANSI VI Bubble tight	
Application	Chilled or hot water up to 60% glycol	

Table 13: 3-Way 2"…4" Valve Assemblies with NEMA 2 SR SmartX Actuators

On/Off	Model Number		Power	Valve Size (inches)	Close Off Pressure (PSI)	CVs @ 90°
	Floating	Proportional				
VBF-02LF3C-S56AXY	VBF-02LF3C-S56FXY	VBF-02LF3C-S56SXY	24 Vac	2"	175	87
VBF-25LF3C-D56AXY	VBF-25LF3C-D56FXY	VBF-25LF3C-D56SXY		2.5"	175	185
VBF-03LF3C-D56AXY	VBF-03LF3C-D56FXY	VBF-03LF3C-D56SXY		3"	175	360
VBF-04LU3C-D56AXY	VBF-04LU3C-D56FXY	VBF-04LU3C-D56SXY		4"	50	740

Replace X with 1 for NO and 2 for NC versions.

Replace Y with N for No Auxiliary and S for Optional two SPDT auxiliary switch models.

Replace C with 1, 2, 3, 4, 5, 6, 7, and 8 = Configurable option at time of ordering in iPortal.

3-Way Butterfly Valve Assemblies (2"…6") with NSR NEMA 2 Actuators

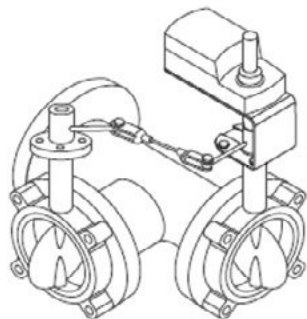

Flow Type	Equal % linear bidirectional Mixing or diverting applications	
Body	Polyester coated cast iron, ASTM A126 Class B lug, Mates with ANSI 125/150 flanges	
Seat	EPDM	
Material	Stem	Stainless steel double D stem
	Stem Seals	Self adjusting double U cup
	Disc	Ductile iron nylon 11 coated disc
Fluid Temperatures	-40...250°F (-40...121°C)	
Close-Off Rating	ANSI VI Bubble tight	
Application	Chilled or hot water up to 60° glycol	

Table 14: 3-way 2"…6" Valve Assemblies with NEMA 2 NSR Actuators

Model Number		Power	Valve size (inches)	Close Off Pressure (PSI)	CVs @ 90°
On/Off Floating	Proportional				
VBF-02LF3C-E24F0Y	VBF-02LF3C-E24S0Y	24 Vac	2"	175	87
VBF-25LF3C-E25F0Y	VBF-25LF3C-E25S0Y		2.5"	175	185
VBF-03LF3C-E25F0Y	VBF-03LF3C-E25S0Y		3"	175	360
VBF-04LU3C-E25F0Y	VBF-04LU3C-E25S0Y		4"	175	740
VBF-04LF3C-E26F0Y	VBF-04LF3C-E26S0Y		4"	50	740
VBF-05LU3C-E26F0Y	VBF-05LU3C-E26S0Y		5"	50	1218
VBF-06LU3C-E26F0Y	VBF-06LU3C-E26S0Y		5"	50	1900
VBF-06LU3C-E26F0Y	VBF-06LU3C-E26S0Y		5"	50	1900

Replace Y with N for no auxiliary and S for optional two SPDT auxiliary switch models.
Replace C with 1, 2, 3, 4, 5, 6, 7, and 8 = Configurable option at time of ordering in iPortal.

3-Way Nylon 11 Disc Butterfly Valve Assemblies (2"…16") with NSR NEMA 4 Actuators

Table 15: 3-Way 2"…16" Valve Assemblies with NEMA 4 NSR Actuators

Model Number		Power ^(a)	Valve Size (inches)	Close Off Pressure (PSI)	CVs @ 90°
On/Off	Modulating				
VBF-02LF3C-E10A0S	VBF-02LF3C-E12S0S	E = 120 Vac F = 24 Vac	2"	175	87
VBF-25LF3C-E10A0S	VBF-25LF3C-E12S0S		2.5"	175	185
VBF-03LF3C-E10A0S	VBF-03LF3C-E12S0S		3"	175	360
VBF-04LU3C-E10A0S	VBF-04LU3C-E12S0S		4"	50	740
VBF-04LF3C-E10A0S	VBF-04LF3C-E12S0S		4"	175	740
VBF-05LU3C-E10A0S	VBF-05LU3C-E12S0S		5"	50	1218
VBF-05LF3C-E20A0S	VBF-05LF3C-E22S0S		5"	175	1218
VBF-06LU3C-E20A0S	VBF-06LU3C-E22S0S		6"	50	1900
VBF-06LF3C-E20A0S	VBF-06LF3C-E22S0S		6"	175	1900
VBF-08LU3C-E30A0S	VBF-08LU3C-E32S0S		8"	50	3765
VBF-08LF3C-E40A0S	VBF-08LF3C-E42S0S		8"	175	3765
VBF-10LU3C-E40A0S	VBF-10LU3C-E42S0S		10"	50	6661
VBF-10LF3C-E50A0S	VBF-10LF3C-E52S0S		10"	175	6661
VBF-12LU3C-E40A0S	VBF-12LU3C-E42S0S		12"	50	10066
VBF-12LF3C-E60A0S	VBF-12LF3C-E62S0S		12"	175	10066
VBF-14LU3C-E60A0S	VBF-14LU3C-E62S0S		14"	50	11598
VBF-14LF3C-E70A0S	VBF-14LU3C-E72S0S		14"	150	11598
VBF-16LU3C-E70A0S	VBF-16LU3C-E72S0S		16"	50	15395
VBF-16LF3C-E80A0S	VBF-16LF3C-E82S0S		16"	150	15395

a - 120 Vac powered models shown, for 24 Vac models change the letter E to F. Example VBF-02LF3C-F10A0S would be 24 Vac powered.
E3x, E5x, E7x, E8x and E9x only available in 120 Vac.
Replace C with 1, 2, 3, 4, 5, 6, 7, and 8 = Configurable option at time of ordering in iPortal.

Butterfly Valves and Actuators

Standard Valve Body Technical Data

Service	Hot and chilled water, up to 60% glycol See EN-205 Water System Guidelines F-26080	Body	A536 Gr. 65-45-12 High Temperature Polyester Coated Ductile Iron
Fluid Temperature Limits	-40...250°F (-40...120°C)	Disc	Nylon 11 Coated and 316 Stainless Steel
Sizes	2...20" 2-Way models 2...16" 3-Way models	Seat	EPDM (Ethylene Propylene Diene Monomer)
Neck	2" extended neck	Stem	416 Stainless Steel
Flow	Bidirectional	Upper & Lower	Steel/Bronze
Leakage	ANSI VI Bubble Tight	Stem Bearing	+ PTFE Self-lubricating
		Tee	Ductile iron (3-Way valves only)

CV Flows Based on Disc Position

Table 16: CV Values^a

Valve Size	Angle of Disc Opening								
	10°	20°	30°	40°	50°	60°	70°	80°	90°
2"	1	1	15	29	46	66	73	86	87
2.5"	1	8	26	44	66	98	141	177	185
3"	2	22	43	71	112	171	256	338	360
4"	8	37	78	118	192	310	505	689	740
5"	9	53	98	170	288	470	759	1131	1218
6"	13	86	175	297	479	757	1190	1715	1900
8"	19	121	254	429	754	1247	2096	3376	3765
10"	37	178	365	728	1215	2005	3342	5814	6661
12"	69	240	492	1008	1696	2868	4961	8455	10066
14"	110	287	609	1141	1975	3328	5571	9269	11598
16"	147	421	844	1547	2651	4440	7412	12214	15395
18"	190	470	968	1807	3228	5509	9382	18231	20120
20"	230	675	1341	2455	4210	7056	11803	19637	25329

a - $CV \times 0.865 = Kvs$

CV is defined as the volume of water in US gallon per minute (GPM) that flows through a given restriction or valve opening with a pressure drop of one PSI at room temperature.

Required Tightening Torque Standard Valve

Table 17: Required Tightening Torque

Valve Size	Bolt Size (inches)	Maximum Bolt Torque Requirement (ft-lbs)
2" & 2.5"	5/8 - 11 Thread UNC - 2B	30
3"	5/8 - 11 Thread UNC - 2B	35
4"	5/8 - 11 Thread UNC - 2B	35 - 40
5"	3/4 - 10 Thread UNC - 2B	35 - 45
6"	3/4 - 10 Thread UNC - 2B	35 - 50
8"	3/4 - 10 Thread UNC - 2B	45 - 55
10"	7/8 - 9 Threads UNC - 2B	55 - 75
12"	7/8 - 9 Threads UNC - 2B	65 - 110
14" & 16"	1 - 8 Threads UN - 2B	75 - 120
18" & 20"	1-1/8 - 8 Threads UN - 2B	85 - 130

BOLT TIGHTENING SEQUENCE (TYPICAL)

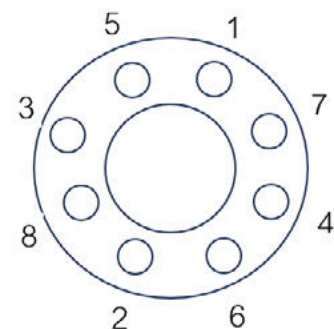

Installation: Lower the valve into the open pipe work with the disc in the 10° open position. Valves with non-spring actuators are shipped in this position. Once the valve is placed in the pipe work, turn the disc to the full-open position. Gradually remove the flange spreaders (if used). Center the valve body to the flanges, and tighten the bolts hand-tight. Slowly close the valve clockwise to check for adequate disc clearance. Return disc to full-open position and cross tighten all bolts to proper torque specification (see tightening pattern above). Do NOT install with the disc in a fully closed position. This will cause seat distortion. When flange bolts are tightened, rubber will close around disc edge creating excessive torque in initial operation.

High Performance Valve Assemblies

2.5"...18" 2-Way High Performance Valve Assemblies

Product Description

Schneider Electric's High Performance Butterfly Valves are ideally suited to both high pressure, high temperature, high cycle HVAC applications and mission critical HVAC applications. This includes chiller isolation, cooling tower isolation, change-over systems, large air handler's coil control, bypass and process control applications. With ANSI Class 150 rating, all valves are tested for bubble tight close-off to API 598 standards at maximum rated differential pressure.

Features

Double Offset Stem/Disc Design
 - Reduced seat wear, zero leakage, and low torque
 Blow-out Proof Stem
 - Safety and ease of use
 Energized RTFE Seat
 - Zero leakage, self-adjusting for wear and easy field replacement

Pressured Assisted, but not Pressure Dependent Seat Design
 - Optimal performance and sealing at high or low differential pressures
 Adjustable PTFE packing
 - Packing can be adjusted while the valve is in service
 Dead End Rating Equal to Nominal Pressure
 - Allows the control valve to function as an isolation valve

High Performance Valve Body Technical Data

Service	Hot Water, Chilled Water Condenser Water, Steam	Materials	
Fluid Temperature Limits	-40...500°F	Body	Carbon Steel
Max Steam Pressure	On/Off 150 PSI Proportional 50 PSI	Stem	17-4 Stainless Steel
Sizes	2.5"...18"	Disc	316 Stainless Steel
Flow Characteristic	Modified Equal Percentage	Seat	RTFE
Leakage	ANSI VI Bubble Tight		

Table 18: 2-Way High Performance Butterfly Valve Assemblies with NSR NEMA 4 Actuator, Hand Wheel with Two SPDT Auxiliary Switches and Heater

Model Number		Power	Valve Size (inches)	Close Off Pressure (PSI)	CVs @ 90°
On/Off	Modulating				
VBF-25HF20-E10A0S	VBF-25HF20-E12S0S	120 Vac	2.5"	285 psi	160
VBF-03HF20-E10A0S	VBF-03HF20-E12S0S		3"		185
VBF-04HF20-E20A0S	VBF-04HF20-E22S0S		4"		375
VBF-05HF20-E30A0S	VBF-05HF20-E32S0S		5"		790
VBF-06HF20-E30A0S	VBF-06HF20-E32S0S		6"		1350
VBF-08HF20-E40A0S	VBF-08HF20-E42S0S		8"		2800
VBF-10HF20-E50A0S	VBF-10HF20-E52S0S		10"		4300
VBF-12HF20-E60A0S	VBF-12HF20-E62S0S		12"		6650
VBF-14HF20-E70A0S	VBF-14HF20-E72S0S		14"		7650
VBF-16HF20-E80A0S	VBF-16HF20-E82S0S		16"		9800
VBF-18HF20-E90A0S	VBF-18HF20-E92S0S	18"	10500		

Model Number		Power	Valve Size (inches)	Close Off Pressure (PSI)	CVs @ 90°
On/Off	Modulating				
VBF-25HF20-F10A0S	VBF-25HF20-F12S0S	24 Vac	2.5"	285 psi	160
VBF-03HF20-F10A0S	VBF-03HF20-F12S0S		3"		185
VBF-04HF20-F20A0S	VBF-04HF20-F22S0S		4"		375
VBF-05HF20-F40A0S	VBF-05HF20-F42S0S		5"		790
VBF-06HF20-F40A0S	VBF-06HF20-F42S0S		6"		1350
VBF-08HF20-F40A0S	VBF-08HF20-F42S0S		8"		2800
VBF-10HF20-F60A0S	VBF-10HF20-F62S0S		10"		4300
VBF-12HF20-F60A0S	VBF-12HF20-F62S0S		12"		6650

Butterfly Valves and Actuators

Table 19: Cv Values^a

Valve Size	Disc Position in Degrees								
	10°	20°	30°	40°	50°	60°	70°	80°	90°
2.5"	3	8	16	30	50	78	100	136	160
3"	5	14	32	56	87	123	155	178	185
4"	10	31	63	115	175	250	315	365	375
5"	16	41	78	146	238	360	500	675	790
6"	35	81	140	218	330	510	750	1070	1350
8"	65	165	280	456	685	1060	1590	2230	2800
10"	100	250	450	700	1050	1630	2430	3450	4300
12"	155	390	700	1080	1630	2530	3750	5330	6650
14"	175	450	810	1250	1890	2900	4300	6100	7650
16"	230	580	1020	1530	2420	3700	5510	7560	9800
18"	170	500	1180	2220	3520	5100	6960	9100	10500

a. $Cv \times .865 = Kvs$

Cv is defined as the volume of water in US gallons per minute (GPM) that flows through a given restriction or valve opening with a pressure drop of one PSI at room temperature.

The best equal percentage flow characteristic is between 20 to 70 degrees of disc opening. Above 70 degrees the flow characteristic is primarily quick opening. Application engineers requiring good equal percentage floating or proportional control should size the valve for the required Cv according to the table, and limit the disc rotation to a maximum of 70 degrees in the field. Various methods can be used to limit the disc rotation including in the controller, electrically at the actuator (for proportional actuators only), or mechanically at the actuator. Two position actuators should not be selected for applications requiring equal percentage flow characteristics.

Required Tightening Torque High Performance

BOLT TIGHTENING SEQUENCE (TYPICAL)

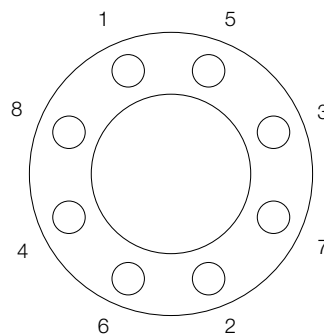

Table 20: High Performance H1 Valve Bodies Required Tightening Torque^a

Valve Size (inches)	Bolts Size / Threads UNC-28	# of Holes	Max Bolt Torque (ft-lbs)
2.5	5/8 -11	4	22
3	5/8 -11	4	30
4	5/8 -11	8	36
5	3/4 -10	8	49
6	3/4 -10	8	62
8	3/4 -10	8	107
10	7/8 -9	12	110
12	7/8 -9	12	156
14	1 - 8	12	228
16	1 - 8	16	268
18	1 1/8 - 8	16	400

Installation: Lower the valve into the open pipe work with the disc in the 10° open position. Valves with non-spring actuators are shipped in this position. Once the valve is placed in the pipe work, turn the disc to the full-open position. Gradually remove the flange spreaders (if used). Center the valve body to the flanges, and tighten the bolts hand-tight. Slowly close the valve clockwise to check for adequate disc clearance. Return disc to full-open position and cross tighten all bolts to proper torque specification. Do NOT install with the disc in fully closed position. This will cause seat distortion. When flange bolts are tightened, rubber will close around disc edge creating excessive torque in initial operation.

2.5"…18" High Performance Valve Assembly Dimensions with NSR NEMA 4 Actuators

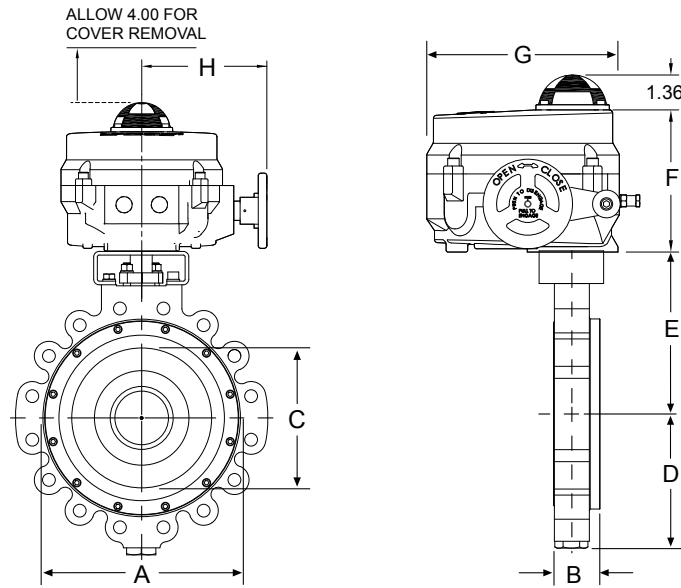
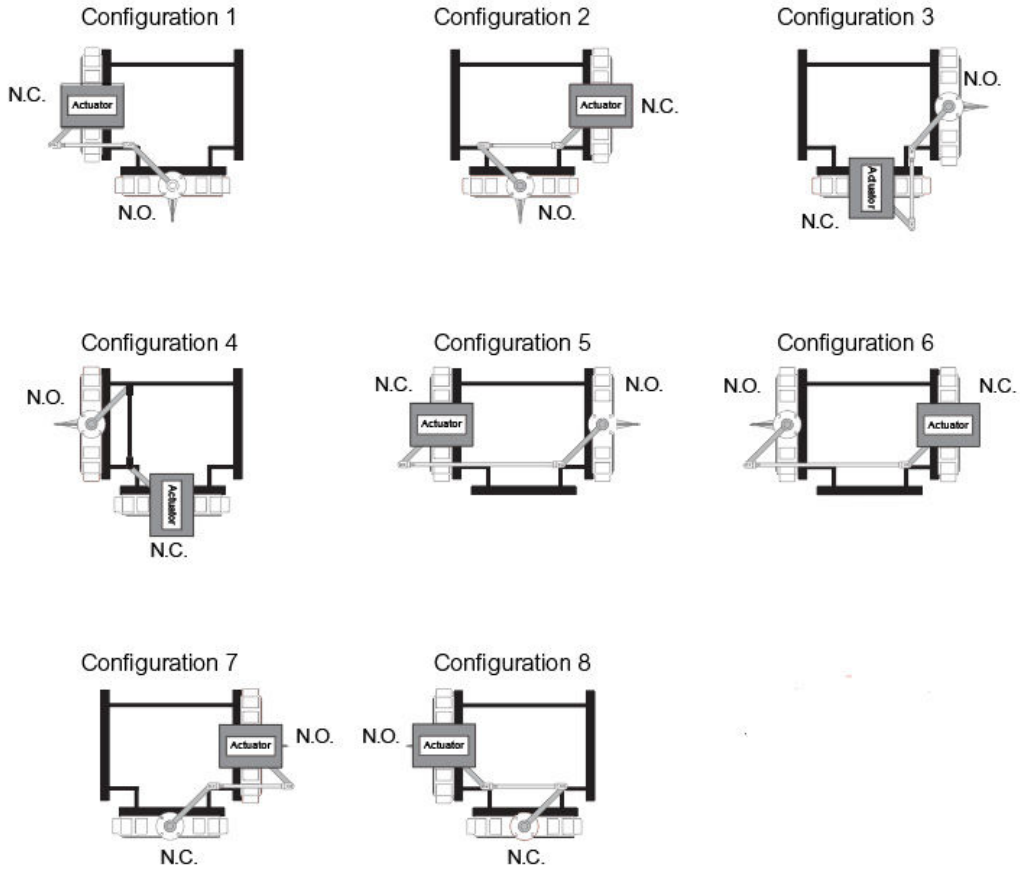

Table 21: 2"…18" 2-Way High Performance Butterfly Valve Assemblies with NSR NEMA 4 Actuator Dimensions

Valve Assembly Part No	Valve Size (in inches)	Dimensions in inches (mm)								
		A	B	C	D	E	F	G	H	I (Lug Bolt Threads)
VBF-25HF20-E10A0S	2.5"	4.75	1.88	2.28	3.81	6.38	5.6	7.5	5.8	5/8-11
VBF-03HF20-E10A0S	3"	5.25	1.88	2.86	4.09	6.63	5.6	7.5	5.8	5/8-11
VBF-04HF20-E20A0S	4"	6.72	2.03	3.72	4.71	7.5	5.6	7.5	5.8	5/8-11
VBF-05HF20-E30A0S	5"	7.62	2.23	4.8	5.07	7.5	6.6	10.1	7.8	3/4-10
VBF-06HF20-E30A0S	6"	8.62	2.23	5.88	5.57	8	6.6	10.1	7.8	3/4-10
VBF-08HF20-E40A0S	8"	10.81	2.4	7.8	6.94	9.5	6.6	10.1	7.8	3/4-10
VBF-10HF20-E50A0S	10"	13.06	2.75	9.78	8.56	10.75	7.2	12.1	9.5	7/8-9
VBF-12HF20-E60A0S	12"	15.42	3.08	11.74	10.18	12.25	7.2	12.1	9.5	7/8-9
VBF-14HF20-E70A0S	14"	17.24	3.73	12.9	11.95	14.5	7.2	12.1	9.5	1" -8
VBF-16HF20-E80A0S	16"	19.5	4.11	14.68	12.94	17.75	12.5	18.8	9.5	1" -8
VBF-18HF20-E90A0S	18"	21.38	4.61	16.6	14.15	20	12.5	18.8	9.5	1 1/8" -8

3-Way Butterfly Valve Configurations

Spring Return and Non-Spring Return



Note: Please select the desired configuration for all 3-Way butterfly valve assembly orders. Schneider Electric must have the specification in order to manufacture the appropriate linkage kit. Please reach out to Customer Care while ordering or choose the right configuration from the dropdown list in your cart when ordering through iPortal.

INSTRUMENTATION AND CONTROL FOR HVAC

ACTUATORS

A. Electronic Direct Couple Damper (and Valve) Actuators

[Schneider Electric SmartX Actuators]

1. Manufactured, brand labeled or distributed by Schneider Electric.
2. Direct-coupled type non-hydraulic designed for minimum 100,000 full-stroke cycles at rated torque.
3. Direct-coupled damper actuators must have a five-year warranty.
4. Size for torque required for damper seal at maximum design conditions and valve close-off pressure for system design.
5. Direct-coupled damper actuators should accommodate 3/8", 1/2" 1.05" round or 3/8"-1/2" and 3/4" square damper shafts.
6. Actuator operating temperature minimum requirements: 44, 88 and 133lb.-in. are -25°F-130°F (-32°C-55°C). The 30, 35, 60, 150 and 300lb.-in. are -25°F-140°F (-30°C-60°C). The 270lb.-in. are -22 °F-122°F (-30 °C-50°C).
7. Overload protected electronically throughout rotation except for selected Floating actuators - they have a mechanical clutch.
8. Spring Return Actuators: Mechanical fail safe shall incorporate a spring return mechanism.
9. Non-Spring Return Actuators shall stay in the position last commanded by the controller.
10. Power Requirements: 24Vac/dc [120Vac] [230Vac].
11. Proportional Actuator controller input range from 0-10Vdc, 2-10Vdc or 4-20mA models.
12. Housing: Minimum requirement NEMA type 2.
13. Actuators with a microprocessor should not be able to be modified by an outside source (cracked or hacked).
14. Actuators of 133 and 270lb.-in. of torque or more should be able to be tandem mount or "gang" mount.
15. Agency Listings: ISO9001, cULus, CE and CSA.

B. 1/2"-3/4" Ball Valve Electronic Actuators

[Schneider Electric VBB/VBS ball valves actuators]

1. Manufactured, brand labeled or distributed by Schneider Electric.
2. Size for torque required for valve close-off pressure for system design.
3. Coupling: Direct coupled to the valve body without the use of external devices or tools (snap-on).
4. Auxiliary End Switch (optional) is to be SPST 24Vac/Vdc, 101mA to 5mA maximum on selected two-position models.
5. Controller Signal Two-position, Floating or Proportional (0-5 Vdc, 0-10 Vdc, 5-10 Vdc, or 4-20mA dc). The design allows for changing selections via DIP switches without removal of cover.
6. Manual operating lever and position indicator must be and are on all models.
7. Power Requirements: 24 Vac for floating, proportional, and 110-230 Vac for two position multi-voltage types.
8. Actuators must be available with either Spring Return (SR) or Non-Spring Return (NSR) models.
9. Operating Temperature Limit Floating is to be 32-140°F (0-60°C) Proportional 32-140°F (0-60°C) Two-Position 32-169°F (0-76°C).
10. Wiring (depending on model) Removable Terminal Block, 10 ft. (3.05 m) Plenum Cable, 18 in. (45cm) Appliance Wire.
11. Locations must be rated NEMA 2, IEC IP31 (Indoor Use Only). Actuators with terminal block or plenum cable leads are plenum rated per UL file number E9429.
12. Agency Listings: ISO9001, cULus, and CE.
13. Schneider Electric shall warrant all components for a period of 5 years from the date of production.

C. 2-Way (1/2"-3") and 3-Way (1/2"-2") Ball Valve Actuators

[Schneider Electric VB-2000 ball valves actuators]

1. Manufactured, brand labeled or distributed by Schneider Electric.
2. Size for torque required for valve close-off pressure for system design.
3. Actuators are to be available in spring return (SR) and non-spring return (NSR) models. Spring Return (SR) actuators are to provide a choice to return direction.
4. Actuators are to be available in models for two-position, floating and proportional control.
5. All actuator models are to be equipped with pigtail leads.
6. Actuators must be available in models with manual override.
7. Actuators must be available in models with auxiliary switch(es).
8. Operating temperatures: Non-Spring Return (NSR) actuators with 44 and 88 lb.-in. of torque must be -25 to 130°F (-32 to 55°C). All other actuators are -22 to 140°F (-30 to 60°C).
9. Actuators must be NEMA 2 rated.
10. All actuators are to have a five-year warranty.
11. Agency Listings: ISO9001, cULus, and CE.

D. Zone Valve Actuators - Two-position Spring Return (SR)

[Schneider Electric Erie Zone Valve PopTop™ Two-position valve actuators]

1. Manufactured, brand labeled or distributed by Schneider Electric.
2. Valves are to be two-position (On-Off), spring return (SR) with general or high close off models.
3. Actuator Voltage Models are 24Vac@ 50/60Hz, 110Vac@ 50Hz and 120Vac@ 60Hz, 230Vac@ 50Hz, 240Vac@ 60Hz, 208Vac@ 50/60Hz, 277Vac@50/60Hz.
4. End (auxiliary) Switch, 24 -240 Vac Models: 24–250 Vac/101 mA min. to 5 A max. and 9–30 Vdc @100 mA max. 277Vac.
5. Actuators are to have manual override on normally closed (NC) models and assemblies to valves without the use of tools, linkages or calibration.
6. Actuators are to have a hysteresis synchronous motor.
7. North America Agency Listings: UL873: Underwriters laboratories (Category Temperature Indicating and Regulating Equipment). CUL: UL Listed for use in Canada by Underwriters Laboratory. Canadian Standards C22.2 No. 24.

E. 2"–18" 2-Way and 2"–16" 3-Way Butterfly Valve Non-Spring Return (NSR) Linear Electronic Valve Actuators with Linkage Butterfly Valve Actuators

[Schneider Electric S70 red w/ handwheel, w/ heater actuators]

1. Manufactured, brand labeled or distributed by Schneider Electric.
2. The butterfly valve actuators are to be Non-Spring Return (NSR) two-position and proportional taking 0–10 Vdc or 4–20 mA models. All actuators are to be NEMA 4, manual override (handwheel) two auxiliary switches, and built-in heater.
3. Actuator close-offs and CVs must be appropriate for the valve size in a typical HVAC application.
4. Actuators must be available in 24 Vac and 120 Vac models.
5. Actuators must have internal wiring isolation for parallel wiring multiple units that eliminates the risk of feedback from one actuator to another.
6. Proportional models must have feedback of 0–10 Vdc or 4–20 mA.
7. Actuator operating temperature shall be -40–150°F (-40–60°C).
8. Actuator agency listings (North America) UL, CSA and CE.

F. 2"–4" 2-Way and 3-Way Butterfly Valve Spring Return (SR) Electronic Valve Actuators

[Schneider Electric SmartXMx41-7153 actuators]

1. Manufactured, brand labeled or distributed by Schneider Electric.
2. The butterfly valve actuators are to be Spring Return (SR) two-position and proportional taking 2–10 Vdc or 4–20 mA models. All actuators are to be NEMA 2.
3. Actuator close-offs and CVs must be appropriate for the valve size in a typical HVAC application.
4. Actuators must be available in 24 Vac models.
5. Actuators shall have two SPDT auxiliary switch models.
6. Actuators must have internal wiring isolation for parallel wiring multiple units that eliminates the risk of feedback from one actuator to another.
7. Proportional models must have feedback of 2–10 Vdc or 4–20 mA.
8. Actuator operating temperature shall be -22–140°F (-12–60°C).
9. Actuators are to have a 5-year warranty.
10. Actuator agency listings (North America) UL, CSA and CE.

G. 2"–6" 2-Way and 3-Way Butterfly Valve Non-Spring Return (NSR) Electronic Valve Actuators

[Schneider Electric SmartXNR-22xx-5xx actuators]

1. Manufactured, brand labeled or distributed by Schneider Electric.
2. The butterfly valve actuators are to be Non-Spring Return (NSR) two-position and proportional taking 0–10Vdc or 4–20mA models. All actuators are to be NEMA 2.
3. Actuator close-offs and CVs must be appropriate for the valve size in a typical HVAC application.
4. Actuators must be available in 24Vac models.
5. Actuators shall have two SPDT auxiliary switch actuators must have internal wiring isolation for parallel wiring multiple units that eliminates the risk of feedback from one actuator to another.
6. Proportional models must have feedback of 2–10 Vdc or 4–20 mA.
7. Actuator operating temperature shall be -22–140°F (-12–60°C).
8. Actuators are to have a 5-year warranty.
9. Actuator agency listings (North America): UL, CSA and CE.

H. ½"–2" Bronze Body, Linear Electronic Valve Actuators with 67 or 78lbs. of force Globe Valve Actuators

[Schneider Electric MG350V]

1. Manufactured, brand labeled and distributed by Schneider Electric.
2. Actuator must have bi-color LED status indication for motion indication, autocalibration and alarm notification.
3. When the actuator is properly mounted, it must have a minimum of a NEMA 2 (IP53) rating.
4. Actuators are to be non-spring return.
5. Actuators are to be floating (used for two-position) or proportional models.
6. Proportional models will have optional models with a position output signal with field selectable 2–10 Vdc and 0–10 Vdc input signals and selectable input signal director reverse acting.
7. Actuator must have autocalibration which provides precise control by scaling the input signal to match the exact travel of the valve stem.
8. Actuators must come in models with Pulse Width Modulated (PWM) with field-selectable 0.59 to 2.93 sec and 0.1 to 25.5 sec input signal ranges with a position output signal.
9. Actuators must have manual override with automatic release.
10. Models with position feedback output signal include field selectable 2–10Vdc or 0–5 Vdc output signal
11. Removable wiring screw terminal with ½" conduit opening.
12. Actuator operating temperature ranges:
 - a. When controlling fluid up to 266°F (130°C) = ambient air temperature is to be 23–131°F (-5–55°C).
 - b. Fluid up to 281°F (138°C) = 23–127°F (-5–53°C).
 - c. Fluid up to 340°F (171°C) = 23–115°F (-5–46°C).
 - d. Fluid up to 400°F (204°C) = 23–102°F (-5–39°C).
13. Actuator agency Listings (North America).
 - a. cUL-us LISTED mark, per UL 60730-1 and -2-14 and CAN/CSA E60730-1 and -2-14 Automatic Electric Controls.
 - b. NEMA 2.
 - c. NEC class 2 FCC part-15 class B.
 - d. Canadian ICES-003.
 - e. ESA registered.
 - f. Plenum rated per UL2043.

I. ½"–2" Bronze Body, Linear Electronic Valve Actuators with 105lbs. of force Globe Valve Actuators

[Schneider Electric SmartXMx51-7103 Series Linear SR Valve Actuator]

1. Manufactured, brand labeled and distributed by Schneider Electric.
2. Actuators must have Two-Position, Floating, and Proportional models.
3. Proportional models with a controller input signal of either 0–10Vdc, 2–10Vdc, 4–20mAdc, 0–3 Vdc, or 6–9 Vdc. Control function direct/reverse action is switch selectable on most models.
4. Actuator force is to be 105lb (467 newton) with ½" (13 mm) nominal linear stroke.
5. Power requirements 24 Vac, 120 Vac or 230 Vac depending on model.
6. Actuator housings rated for up to NEMA2/IP54.
7. Actuator is to have overload protection throughout stroke.
8. Actuator operating temperature -22–140°F (-30–60°C).
9. Actuator must automatically set input span to match valve travel.
10. Actuator must have manual override to allow positioning of valve and preload.
11. Actuator is to be spring return.
12. Actuator is to mount directly to valves without separate linkage.
13. Actuator is to have a 5-year warranty.
14. Actuator agency Listings (North America):
 - a. UL873: Underwriters Laboratories (File# E9429 Category Temperature-Indicating and Regulating Equipment).
 - b. CUL: UL Listed for use in Canada by Underwriters Laboratories. Canadian Standards C22.2 No.24-93.

J. ½"–2" Bronze Body and other valves Linear Electronic Valve Actuators with 220 of force Globe Valve Actuators

[Schneider Electric SmartXMx51-720x Series Linear SR Valve Actuator]

1. Manufactured, brand labeled and distributed by Schneider Electric.
2. Actuators must have Two-Position for a SPST controller, floating for a SPST controller, and proportional models with a controller input signal of either a 0–10 Vdc, 2–10 Vdc, 4–20 mAdc, or 6–9Vdc. Control function direct/reverse action is jumper selectable.
3. Actuator is to be spring return.
4. Actuator will have 220 lb. force (979 newton) with ½" (13 mm) or 1" (25mm) nominal linear stroke.
5. Feedback on proportional model with 2–10 Vdc (max. 0.5 mA) output signal or to operate up to four additional slave actuators.
6. Actuator operating temperature is 0–140°F (-18–60°C).
7. Actuator must automatically set input span to match valve travel.
8. Actuator is to have a 24 Vac power supply on two-position and proportional models and 120 Vac on two-position models.
9. Actuator housings rated for up to NEMA2/IP54.
10. Actuator must have manual override to allow positioning of valve and preload.
11. Actuator is to mount directly to valves without separate linkage.
12. Actuator is to have a 5-year warranty.
13. Actuator agency Listings (North America):

- a. UL873: Underwriters Laboratories (File #E9429 Category Temperature-Indicating and Regulating Equipment).
- b. CUL: UL Listed for use in Canada by Underwriters Laboratories. Canadian Standards C22.2 No.24-93.

K. ½”–2” Bronze Body, Spring Return (SR) Linear Electronic Valve Actuators with Linkage Globe Valve Actuators

[Schneider Electric SmartX Actuators]

1. Manufactured, brand labeled or distributed by Schneider Electric.
2. Actuators with 35, 60, 133, or 150lb.-in of force depending on model.
3. Actuator housings rated for up to NEMA 2/IP54 with a 150lb.-in. rated a NEMA 4.
4. Actuators are to be spring return.
5. Actuators are to have Two-position, Floating and Proportional models.
6. Actuators must have overload protection throughout rotation.
7. Actuator are to have an optional built-in auxiliary switch to provide for interfacing or signaling on selected models.
8. Actuators are to have a 5-year warranty.
9. Actuator agency listings (North America):
 - a. UL-873 Underwriters Laboratories.
 - b. Canadian Standards C22- 2No.24-83, CUL.

L. ½”–2” Bronze Body, Spring Return (SR) Linear Electronic Globe Valve Actuators with Linkage. Non-Spring Return (NSR) Linear Valve Actuator with Linkage.

[Schneider Electric Forta M400A-VB, M800A-VB, M900A and M1500x-VB Screw Mounted on VentaVB-7000s]

1. Manufactured, brand labeled or distributed by Schneider Electric.
2. Actuators are to be either floating SPDT control or proportional control 0–10, 2–10 Vdc or 4–20mA with a 500-ohm resistor included.
3. Actuators are to be direct/reverse with selectable DIP switches.
4. Actuators are to have 90 lb. (400N), 180 lb. (800N), or 337 lb. (1500N) of force on Non-Spring Return (NSR) models. Note: Not every actuator is for every valve.
5. Actuators are to be powered with 24 Vac or 24 Vdc.
6. All Non-Spring Return (NSR) actuators are to be NEMA 2, vertical mount only. Spring Return (SR) actuators are to have NEMA 4 models.
7. Actuators must have manual override to allow positioning of the valve.
8. Actuators must have selectable valve sequencing and flow curves of either equal percentage or linear.
9. Actuators must have feedback.
10. Actuators must have internal torque protection throughout stroke.
11. The operating temperature is to be:
 - a. 122°F (50°C) for chilled water applications.
 - b. 113°F (45°C) ambient at 281°F (138°C) fluid temperature.
 - c. 107°F (42°C) ambient at 300°F (149°C) fluid temperature.
 - d. 100°F (38°C) ambient at 340°F (171°C) fluid temperature.
12. 90°F (32°C) ambient at 366°F (186°C) fluid temperature.
13. Actuator agency listings (North America): UL873, cULus, RCM,CE.

M. 2½”–6” Cast Iron Flanged Globe Valve Body (and other valves) Non-Spring Return (NSR) Linear Electronic Valve Actuators with Linkage

[Schneider Electric Forta M800A and M1500A Tall U-Bolt Actuators]

1. Manufactured, brand labeled or distributed by Schneider Electric.
2. Actuators are to be either floating SPDT control or proportional control 0–10, 2–10 Vdc or 4–20mA with a 500-ohm resistor included.
3. Actuators are to be direct/reverse acting with selectable DIP switch.
4. Actuators are to have 180 lb.(800N) or 337 lb.(1500N) of force.
5. Actuators will need a 24 Vac or Vdc power supply.
6. Actuators are to be rated NEMA 2, vertical mount only.
7. Actuators must have manual override to allow positioning of the valve.
8. Actuators must have selectable valve sequencing and flow curves of either equal percentage to linear. A 2–10 Vac feedback.
9. Actuators must have internal torque protection throughout stroke.
10. The operating temperature is to be:
 - a. 122°F (50°C)For chilled water applications.
 - b. 113°F (45°C) ambient at 281°F (138°C) fluid temperature.
 - c. 107°F (42°C) ambient at 300°F (149°C) fluid temperature.
 - d. 100°F (38°C) ambient at 340°F (171°C) fluid temperature.
11. 90°F (32°C) ambient at 366°F (186°C) fluid temperature.
12. Actuator agency listings (North America) UL873, cULus, RCM, CE.

N. 2½”–6” Cast Iron Flanged Globe Valve Actuators 220lbs. force

1. Actuators must have Two-Position for a SPST controller, Floating for a SPST controller, and Proportional models with a controller input signal of either a 0–10 Vdc, 2–10 Vdc, 4–20 mA, or 6–9Vdc. Control function direct/reverse action is jumper selectable.
2. Actuator is to be Spring Return.
3. Actuator will have 220 lb. force (979 newton) with ½" (13mm) or 1" (25 mm) nominal linear stroke.
4. Feedback on proportional model with 2–10 Vdc (max. 0.5 mA) output signal or to operate up to four additional slave actuators.
5. Actuator must automatically set input span to match valve travel.
6. Actuator operating temperature 0–140°F (-18–60°C) up to a maximum valve fluid temperature of 300°F (149°C).
7. Actuator is to have a 24 Vac power supply on two-position and Proportional models and 120 Vac on two-position models.
8. Actuator housings rated for up to NEMA2/IP54.
9. Actuator must have manual override to allow positioning of valve and preload.
10. Actuator is to mount directly to valves without separate linkage.
11. Actuator agency Listings: UL873, CUL: UL.

O. 2½"–6" Cast Iron Flanged Globe Valve Actuators with Linkage SR.

1. Actuators with 60, 133, or 150lb.-in of force depending on model.
2. Actuator housings rated for up to NEMA 2/ IP54 with a 150lb.-in. rated a NEMA 4.
3. Actuators are to be spring return.
4. Actuators are to have two-position, Floating and Proportional models.
5. Actuators must have overload protection throughout rotation.
6. Actuator have an optional built-in auxiliary switch to provide for interfacing or signaling on selected models.
7. Actuator agency listings: UL-873, C22-2 No.24-83, CUL.

P. Pneumatic Globe Valve Actuators

[Schneider Electric MK Series die-cast aluminum housing actuators]

1. Manufactured, brand labeled or distributed by Schneider Electric.
2. Pneumatic actuators must have field replaceable neoprene diaphragms.
3. All actuators shall be Spring Return (SR) with the spring retracting actuator shaft and raising the valve stem on loss of pressure.
4. Actuators must have an operating temperature of -20–220°F (-29–104°C).
5. Actuators shall be models with 6 sq.in. 11, 50 and 100sq. ineffective area for the psi to push against.
6. Actuators may not "spark" under normal conditions.
7. Actuators must accept an optional positive pilot positioning relay.
8. Actuators will have a maximum air pressure of 30 psig.
9. Actuators must have models with spring ranges for typical HVAC applications.

Q. Pneumatic Damper Actuators

[Schneider Electric MK-0000 die-cast aluminum housing actuators]

1. Manufactured, brand labeled or distributed by Schneider Electric.
2. Pneumatic actuators must have field replaceable neoprene diaphragms.
3. All actuators shall be Spring Return (SR) with the spring retracting actuator shaft on loss of pressure.
4. Actuators must have an operating temperature of -20–160°F (-29–71°C).
5. Actuators shall be models with 8 sq.in. 11, 20 and 40 sq.in. (dual mounted) effective area for the psi to push against.
6. Actuators may not "spark" under normal conditions.
7. Actuators must accept an optional positive pilot positioning relay. Relay is to be standard on 20 sq.in. models.
8. Actuators will have a maximum air pressure of 30 psig.
9. Actuators must have models with spring ranges for typical HVAC applications.

CONTROL VALVES

A. Zone Valves, Two-Position, Control Valves

[Schneider Electric Erie zone valves]

1. Manufactured, brand labeled or distributed by Schneider Electric.
2. Valve application are for hot and chilled water models, up to 50% glycol. Steam models up to 15 psi.
3. Valve seat leakage is to ANSI class IV (0.01%) with pressure at inlet (B-port/A-port, if 3-Way).
4. Valves are to be with Body 300 psi rated forged brass, Stem-nickel plated, Seat-brass, Paddle-BunaN or highly saturated nitrile.
5. Valves are to be 2-Way or 3-Way with connections options of NPT (threaded female), Sweat (SW), Inverted flare (IFL), Society Automotive Engineers male (SAE) Rp Metric threaded female, depending on models, with end switch option on general temperature models.
6. Actuators are to be Spring Return (SR) normally open (NO) and normally closed (NC) models. Actuators are to

- have "High Close-off" models.
7. Valve line sizes are $\frac{3}{4}$ ", $\frac{1}{2}$ ", $\frac{3}{4}$ ", 1", and $1\frac{1}{4}$ " depending on model.
 8. Valve CVs are from 1 to 8 depending on model.
 9. Actuators are to be UL listed.

B. Bronze $\frac{1}{2}$ "–2" Globe Control Valves

[Schneider Electric Venta VB-7000valves]

1. Control Valves: Factory fabricated, with body material, and pressure class based on maximum pressure and temperature rating of piping system with a body rating of not less than 400 psig at 150°F, 321 psig at 281°F per ANSI B16.15.
2. Valve Manufacturer: Must have at least 25 years of valve manufacturing and must meet the provisions of Section 1605 of the American Recovery and Reinvestment Act Buy American Requirements. Manufacturer shall water test all valves prior to shipment.
3. Valves 2-Way NPS 2" and Smaller: Operator, stem and plug assembly, and spring-loaded PTFE/EPDM valve stem packing cartridge must be removable for future replacement to restore the valves back to their original condition. Material grade properties must meet the fluid temperature and pressure requirements:
 - a. Standard duty bronze body, 316 stainless steel vertical stem, brass plug, soft seal, and bronze seat, renewable packing cartridge, and screwed/sweat/flared ends. Valves shall have allowable media temperature of 20°F – 281°F to assure reliability with dual temperature applications.
 - b. Heavy duty bronze body, 316 stainless steel vertical stem, 316 stainless steel plug, soft seal, and 316 stainless steel seat, renewable packing cartridge, and screwed ends. Valves shall have allowable media temperature of 20°F – 340°F to assure reliability with dual temperature applications.
 - c. High temperature bronze body, 316 stainless steel vertical stem, 316 stainless steel plug, and 316 stainless steel seat, renewable packing cartridge, and screwed ends. Valves shall have allowable media temperature of 20°F – 400°F.
4. 2-Way fluid system globe valves shall have the following characteristics:
 - a. Rangeability: Greater than 100:1 for all valves with flow coefficients of 0.4 and higher to provide stable control under light load conditions.
 - b. Maximum Allowable Seat Leakage: Standard and heavy duty valves must be designed to meet ANSI Class V (0.0005 ml per minute per orifice diameter per psi differential) up to 35 psi close off differential pressure and ANSI Class IV seat leakage (maximum 0.01% of full open valve capacity) above 35 psi with appropriate actuator. High temperature valves must meet ANSI Class III seat leakage (maximum 0.1% of full open valve capacity).
 - c. The valve must be able to operate with a full-open operating differential of no less than 87 psi.
 - d. Flow Characteristics: Modified equal percentage characteristics for standard duty water applications and modified linear for heavy duty and high temperatures team applications with gradual opening for light loads.
 - e. Sizing:
 - Two Position Water: Line size or size using a differential pressure of 1 psi.
 - Modulating Water: 5PSI or twice the load pressure drop.
 - Pressure drop across steam valve at a maximum flow of 80 percent of inlet pressure up to 15psig and 42% of absolute (gage pressure +14.7) inlet pressure above 15 psig inlet.
 - 100 psi saturated steam maximum inlet pressure for heavy duty bronze body globe valves $\frac{1}{2}$ "–2".
 - 150 psi saturated steam maximum inlet pressure for high temperature bronze body globe valves $\frac{1}{2}$ "–2".
 - 35 psi saturated steam maximum inlet pressure for standard duty bronze body globe valves $\frac{1}{2}$ "–2".
5. Valves 3-Way mixing (two inlets and one outlet) NPS2" and smaller:
 - a. Operator, stem and plug assembly, and spring-loaded PTFE/EPDM valve stem packing cartridge must be removable for future replacement to restore the valves back to their original condition. Material grade properties must meet the fluid temperature and pressure requirements:
 - Standard duty bronze body, 316 stainless steel vertical stem, brass plug, and bronze seat, renewable packing cartridge, and screwed or sweat ends. Valves shall have allowable media temperature of 20°F – 281°F to assure reliability with dual temperature applications.
 - Heavy duty bronze body, 316 stainless steel vertical stem, 316 stainless steel plug, and 316 stainless steel seat, renewable disc and packing cartridge, and screwed ends. Valves shall have allowable media temperature of 20°F – 340°F to assure reliability with dual temperature applications.
6. 3-Way mixing hydronic system globe valves shall have the following characteristics:
 - Rangeability: Greater than 100:1 for all valves to provide stability.
 - Maximum Allowable Seat Leakage: A port must be designed to meet ANSI Class V (0.0005ml per minute per orifice diameter per psi differential) up to 35 psi close off differential pressure and ANSI IV seat leakage (maximum 0.01% of full open valve capacity) above 35 psi with appropriate actuator. B port must meet ANSI Class III seat leakage (maximum 0.1% of full open valve capacity).
 - The valve must be able to operate with a full-open operating differential of 87 psi.
 - Flow Characteristics: Modified linear characteristics with gradual opening for light loads.
 - Sizing: Modulating Water: Minimum 5 psi or at least equal to the load pressure drop.
7. Valves 3-Way diverting (one inlet and two outlets) NPS2 and smaller:
 - Operator, stem and plug assembly, and spring-loaded PTFE/EPDM valve stem packing cartridge must be removable for future replacement to restore the valves back to their original condition. Valves must

be designed specifically for diverting service and mixing valves designed for mixing service must not be used for diverting applications. Material grade properties must meet the fluid temperature and pressure requirements: Standard duty bronze body, 316 stainless steel vertical stem, brass plug, and bronze seat, renewable disc and packing cartridge, and screwed ends. Valves shall have allowable media temperature of 20°F – 281°F to assure reliability with dual temperature applications.

8. 3-Way diverting hydronic system globe valves shall have the following characteristics:
 - Rangeability: Greater than 100:1 for all valves to provide stable control under light load conditions.
 - Maximum Allowable Seat Leakage: ANSI Class III seat leakage (maximum 0.1% of full open valve capacity).
 - Maximum Allowable Pressure Differential: 35 psi in. an open position.
 - Flow Characteristics: Modified linear characteristics with gradual opening for light loads.
 - Sizing: Modulating Water: Minimum 5 psi or at least equal to the load pressure drop.
9. Required Certifications:
 - Pressure Equipment Directive (PED97/23/EC), RoHS (Restriction of Hazardous Substances) and REACH (Regulation, Evaluation, Authorization, and Restriction of Chemicals), Canadian Registration Number.
10. Valve and Operator:
 - To assure maximum performance and operation of the valve assembly, both the valve and the actuator must be tested and approved by the valve manufacturer to assure compatibility of all components and performance to the specifications.

C. 2"–6" Cast Iron Flanged Valves

[Schneider Electric VB-8000 and VB-9000 valves]

1. Bodies
 - Shall be American Factory fabricated with ASTM A 216 Class B cast iron body material with the pressure class within the maximum pressure and temperature rating of the piping system (125 body rating with not less than 200 psig at 150°F, decreasing to 169 psig at 281°F per ANSA B16.1).
2. Manufacturer
 - Shall have at least 25 years of valve manufacturing and meet the provisions of Section 1605 of the American Recovery and Reinvestment Act, buy American, requirements. All valves shall be water tested by manufacturer prior to shipment.
3. Serviceability
 - 2-Way valve operators, stem and plug assemblies, and spring-loaded PTFE/EPDM valve stem packing cartridges must be removable for future replacement to restore the valves back to their original condition.
4. Construction
 - a. Material grades must meet the fluid temperature and pressure requirement temperatures of 20°F – 281°F to assure reliability throughout all application temperature ranges.
5. Packings
 - Shall be cartridges suitable for replacement as units with standing the full operating temperature ranges, including daily and seasonal fluctuations of water, 60% glycol and steam fluids.
6. Characteristics
 - Rangeability: 2-Way, 100:1 and greater for stable control under light load.
 - Shutoff, 2-Way: Leakage allowed: ANSI Class IV (0.01% of max flow).
 - 3-Way: Leakage allowed: ANSI Class III (0.1% of max flow).
 - Flow curves: 2-Way modified equal percentage characteristic.
 - Mixing and Diverting: Linear, modified with gradual opening for light loads.
7. Piping
 - Diverting valves with the common port at the bottom can be used for mixing.
 - Mixing valves with the common port at the end must not be used for diverting applications.
8. Sizing
 - Two Position Water: Line size or size using a differential pressure of 1 psi.
 - Modulating Water: 5PSI or twice the load pressure drop.
 - Steam, 2-Way: maximum pressure drop across the valve at a maximum flow of 80 percent of inlet pressure up to 15 psig. Above 15 psig inlet, 42% of absolute (gage pressure +14.7) inlet pressure.
9. Certifications for All Models
 - Pressure Equipment Directive (PED97/23/EC), RoHS (Restriction of Hazardous Substances) and REACH (Regulation, Evaluation, Authorization, and Restriction of Chemicals).

D. Steam Control Valves

1. ½"...2" Steam Service Designed Globe Valves
 - a. Body material, and pressure class based on maximum pressure and temperature rating of piping system with a body rating of not less than 400 psig at 150°F, 321 psig at 281°F per ANSI B16.15.

- b. High temperature spring-loaded PTFE/EPDM valve stem packing cartridge must be removable for future replacement to restore the valves back to their original condition. Material grade properties must meet the fluid temperature and pressure requirements:
 - Standard duty bronze body, 316 stainless steel vertical stem, brass plug, soft seal, and bronze seat, renewable packing cartridge, and screwed/sweat/flared ends. Valves shall have allowable media temperature of 20°F ...281°F to assure reliability with dual temperature applications.
 - Heavy duty bronze body, 316 stainless steel vertical stem, 316 stainless steel plug, soft seal, and 316 stainless steel seat, renewable packing cartridge, and screwed ends. Valves shall have allowable media temperature of 20°F ...340°F to assure reliability with dual temperature applications.
 - High temperature bronze body, 316 stainless steel vertical stem, 316 stainless steel plug, and 316 stainless steel seat, renewable packing cartridge, and screwed ends. Valves shall have allowable media temperature of 20°F ...400°F.
 - c. 2-Way fluid system globe valves shall have the following characteristics:
 - Rangeability: Greater than 100:1 for all valves with flow coefficients of 0.4 and higher to provide stable control under light load conditions.
 - Maximum Allowable Seat Leakage: Standard and heavy duty valves must be designed to meet ANSI Class V (0.0005 ml per minute per orifice diameter per psi differential) up to 35 psi close off differential pressure and ANSI Class IV seat leakage (maximum 0.01% of full open valve capacity) above 35 psi with appropriate actuator. High temperature valves must meet ANSI Class III seat leakage (maximum 0.1% of full open valve capacity).
 - The valve must be able to operate with a full-open operating differential of no less than 87 psi.
 - Flow Characteristics: Modified equal percentage characteristics for standard duty water applications and modified linear for heavy duty and high temperature steam applications with gradual opening for light loads.
 - Sizing:
 - a. Pressure drop across steam valve at a maximum flow of 80 percent of inlet pressure up to 15 psig and 42% of absolute (gage pressure + 14.7) inlet pressure above 15 psig inlet.
 - b. 100 psi saturated steam maximum inlet pressure for heavy duty bronze body globe valves ½"...2".
 - c. 150 psi saturated steam maximum inlet pressure for high temperature bronze body globe valves ½"...2".
 - d. 35 psi saturated steam maximum inlet pressure for standard duty bronze body globe valves ½"...2".
 - Certifications for all models: Pressure Equipment Directive (PED 97/23/EC), RoHS (Restriction of Hazardous Substances) and REACH (Regulation, Evaluation, Authorization, and Restriction of Chemicals)
2. 2½"...6" Steam Service Designed Globe Valves
- a. Bodies: Shall be American Factory fabricated with ASTM A 126 Class B cast iron body material with the pressure class within the maximum pressure and temperature rating of the piping system. (125 body rating with not less than 200 psig at 150°F, decreasing to 169 psig at 281°F per ANSA B16.1)
 - b. Serviceability: 2-Way valve operators, stem and plug assemblies and spring-loaded PTFE/EPDM valve stem packing cartridges must be removable for future replacement to restore the valves back to their original condition.
 - c. Construction: Material grades must meet the fluid temperature and pressure requirement temperatures of 20 °F ...281 °F to assure reliability throughout all application temperature ranges.
 - d. Packings: Shall be cartridges suitable for replacement as units withstanding the full operating temperature ranges, including daily and seasonal fluctuations of water, 60% glycol and steam fluids.
 - e. Characteristics:
 - Rangeability: 2-Way, 100:1 and greater for stable control under light load.
 - Shutoff, 2-Way: Leakage allowed: ANSI Class IV (0.01% of max flow)
 - Flow curves: 2-Way modified equal percentage characteristic.
 - Sizing
 - a. Steam, 2-Way: Maximum pressure drop across the valve at a maximum flow of 80 percent of inlet pressure up to 15 psig. Above 15 psig inlet, 42% of absolute (gage pressure + 14.7) inlet pressure.
 - b. Certifications for All Models: Pressure Equipment Directive (PED 97/23/EC), RoHS (Restriction of Hazardous Substances) and REACH (Regulation, Evaluation, Authorization, and Restriction of Chemicals).

E. ½"-¾" Ball Valve

[Schneider Electric VBB/VBS Ball Valves]

1. Manufactured, brand labeled or distributed by Schneider Electric.
2. ½" and ¾" Ball Valves: Forged brass body rated at no less than 600 psi, chrome plated brass ball with blowout

- proof stem or optional stainless steel ball with blow out proof stem.
- 3. Valves are to be in 2-Way and 3-Way configurations.
- 4. Connection: Female NPT end fittings, Teflon® PTFE seat, characterizing disc glass-filled PEEK providing equal percentage flow curve on 2-Way valve.
- 5. Operating Temperature 20–250°F chilled or hot water with up to 60% glycol solution.
- 6. 2-Way and Bypass port should be ANSI Class IV (0.01%of Cv) seat leakage.
- 7. Rangeability must be at least 300:1.
- 8. Tool-free actuator connection.
- 9. System Static Pressure Limit should be 600 psig (4137Pa).
- 10. The manufacturer shall warrant all components for a period of 2 years from the date of production.

F. 2-Way (½”–3”) and 3-Way (½”–2”) Ball Valves

[Schneider Electric VB-2000 series]

- 1. Manufactured, brand labeled or distributed by Schneider Electric.
- 2. Valves must be for control of hot or chilled water, or solutions of up to 50% glycol.
- 3. Ball valves must have close-offs of 40–130psi depending on size.
- 4. Valves will provide Cvs from 0.33–266 depending on size.
- 5. Valve characterizing insert is to be made of glass-filled Noryl™ and provide equal percentage flow.
- 6. Valve body is to be made of forged brass ASTM B283-06 and rated for static pressure of 360 psi at fluid temperatures of 20–250 °F (-7–121 °C).
- 7. All valves are to have balls made of nickel/chromium plated brass with 2-Way valves having stainless steel balls as an option. All valve stems are to be stainless steel with reinforce Teflon® EPDMO-ring seals.
- 8. 2-Way valves are to be ANSI Class IV (0.01%of Cv) shutoff. 3-Way valves are to be ANSI Class IV (0.01% of Cv piped coil-side outlet to the port A only.
- 9. Fluid (water) temperature are a minimum 20°F (-7°C) and a maximum of 250°F (121 °C).
- 10. Valves will have a two year warranty.

G. Pressure Independent Balancing Control Valves ½”–10”

[Schneider Electric SmartX PIBCV]

When selecting pressure independent valves the specifier should also revise section 232113 to NOT include balancing valves and also modify section 230593 to NOT require the individual balancing of each coil/valve combination.

- 1. Manufactured, brand labeled or distributed by Schneider Electric.
- 2. NPS2 and Smaller: PN16, stainless steel components.
- 3. NPS 2½ through 10: Class 125 cast iron body per ASME B16.1-2010, Material class B per ASTM A126-04 (2014), stainless steel components.
- 4. Accuracy NPS¾” and Smaller: The control valves shall accurately control the flow from 0–100% rated flow with a differential pressure range of 2.32–58 psi for low and standard flow units, 5–58 psi for high flow units within 5% offset flow value.
- 5. Accuracy NPS 1 through 1¼: The control valves shall accurately control the flow from 0–100% rated flow with a differential pressure range of 2.9–58 psi for standard flow units, 5–58 psi for high flow units within 5% of set flow value.
- 6. Accuracy NPS 1½ through 4: The control valves shall accurately control the flow from 0–100% rated flow with a differential pressure range of 4.35–58 psi for standard flow units, 8.7 psi to 58 psi for high flow units within 5% of set flow value.
- 7. Accuracy NPS 5 through 10: The control valves shall accurately control the flow from 0–100% rated flow with a differential pressure range of 5.8–58 psi for standard flow units, 8.7–58 psi for high flow units within 5% of set flow value.
- 8. Flow Characteristics: Linear Control, selectable to equal percentage at the proportional valve actuator.
- 9. Field adjustable flow by means of a percentage of rated valve flow.
- 10. Position feedback output signal integrated into all proportional actuators.
- 11. 100% authority with modulating below 1% regardless of flow settings.
- 12. No cartridges requiring replace mentor maintenance.
- 13. Close off ratings shall be 232 psi for all valve sizes.

H. Butterfly Valves

- 1. Manufactured, brand labeled or distributed by Schneider Electric.
- 2. Valve body are to be polyester coated iron ASTMA 126 lug mating with ANSI class 125/150 flanges.
- 3. Disc Type: Ductile iron nylon 11 coated.
- 4. Valve Stem:
 - a. 2–8” 416 stainless steel double D stem.
 - b. 10–12” 316 stainless steel double D stem.
 - c. 14” and larger: stainless steel round shaft woodruff key slot.
- 5. Valve Seat:
 - a. EPDM tongue and groove seat and molded O-ring flange seat.
- 6. Flow Characteristics: Modified equal percentage.
- 7. Close-Off Pressure Rating: Bubble-tight shutoff (no leakage).
- 8. Valve Fluid Temperature Rating: -40–250°F (-40–121°C).
- 9. Valve will have two (2) inch extended neck (because of heat).
- 10. Valve must accept pneumatic or electric/electronic actuators.

11. Valves must have a minimum of a two (2) year warranty.

I. High Performance Butterfly Valves

1. Manufactured, brand labeled or distributed by Schneider Electric.
2. Valve body are to be in carbon steel with ANSI class 150 flanges.
3. Disc Type: 316 stainless steel.
 - a. Valve Stem: 17-4PH stainless steel.
 - b. One-piece design.
 - c. Blowout proof design.
4. Valve Seat:
 - a. Resilient energizer totally encapsulated by the PTFE seat.
 - b. Seat assembly locked in the body recess by full-faced seat retainer.
 - c. Self adjusting for temperature changes and wear.
5. Flow Characteristics: Modified equal percentage.
6. Close-Off Pressure Rating: Bubble-tight shut off (no leakage) at rated maximum differential pressure.
7. Valve Fluid Temperature:
 - a. 40–500°F (-40–250°C).
 - b. On/Off steam application max.150 psi pressure.
 - c. Proportional steam application max.50 psi pressure.
8. Valve will have extended neck (because of heat).
9. Valve must accept pneumatic or electric/electronic actuators.
10. Valve must have a minimum two (2) year warranty.

Life Is On



Schneider Electric Americas

Boston ONE Campus
800 Federal Street
Andover, MA 01810-1067
Tel: +1-978-794-0800

Schneider Electric EMEA

Mobilvägen 10
SE-223 62, Lund, Sweden
Tel: +46 (40) 38 68 50

Schneider Electric Hong Kong Ltd

11/F, Kerry Centre,
683 King's Rd,
Quarry Bay, Hong Kong
Tel:+853 2875 1738

www.se.com

