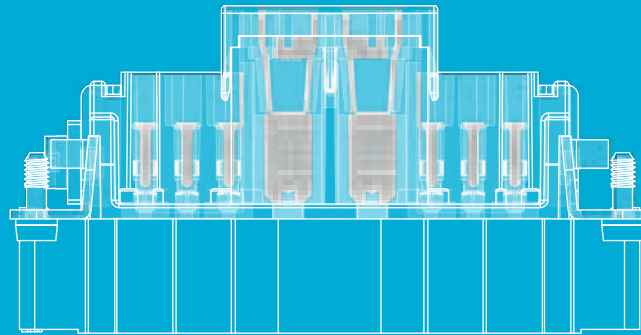
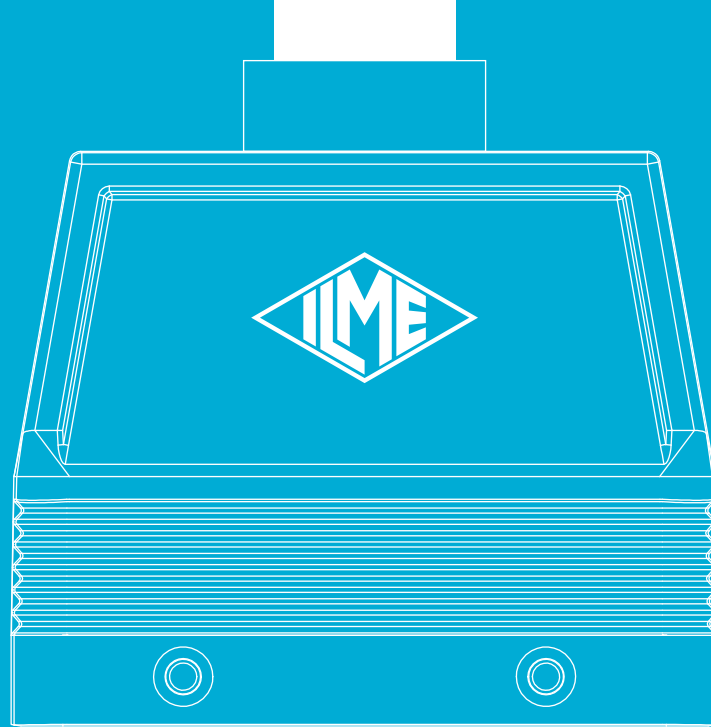
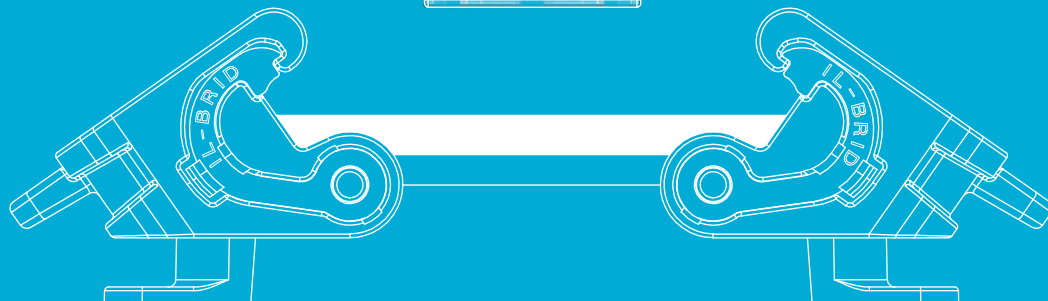
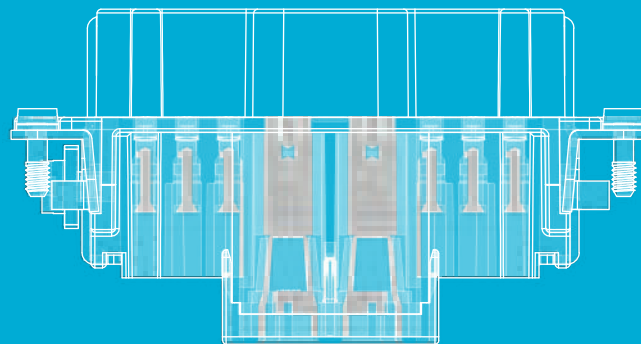


2
0
2
5



GENERAL CATALOGUE



DISCLAIMER

The information provided in this Catalogue is valid at the date of publication.

Updated information may be available online at <https://www.ilme.com>:

- 🔍 checking the relevant section of ILME website for latest release of this Catalogue;
- 🔍 consulting the specific online product data sheet;
- 🔍 checking the latest Certifications available for download.



GENERAL CATALOGUE

Multipole Connectors
for Industrial Purposes



THE TRADITION OF INNOVATION SINCE 1945



ILME designs and manufactures complete solutions for industrial connections.

Headquartered in Milan and with subsidiaries in the key countries driving the progress of automation, ILME is an industry leader in the main world markets.

People are vital to success and growth at ILME, sharing a passion for innovation, utmost responsibility and participation.

The Company is committed to developing technology in the areas that mostly impact the future of the industries it serves: original solutions and safe wiring, research on the most suitable materials, rapid turnaround and readily available services, while striving for energy saving and environmental safeguard.

COMMITMENT TO INDUSTRY

Technological innovation is the main pillar of ILME competitiveness.

In the electrical connection sector of industrial automation, characterized by the need for top performance and reliability, ILME is an acknowledged leader with its own patents, and a global benchmark supplier of major companies worldwide.

ILME offers a fully integrated range of high-quality products and services for many types of connection to suit a wide range of application requirements.



AUTOMATION



RAILWAY



ENERGY



MARINE



**FOOD
& BEVERAGE**



AGRONOMY



OUTDOOR



HEAVY VEHICLES



**LIGHT
& SOUND**



PLASTICS



CHEMICAL



AIRPORTS

PRACTICAL ADVICES FOR CONSULTING THE CATALOGUE

This General Catalogue is divided into **11 sections** each marked by a different letter, grouping together products by their line. This makes its consultation easier.

"MODULAR" PAGE LAYOUT

- 1 Technical descriptions and product series.
- 2 Products descriptions, Part numbers, 2D drawings, and Wiring information
- 3 Section and product series.
- 4 Materials and accessories.
- 5 List of the possible combinations between inserts and enclosures.
- 6 Derating diagrams.

STANDARD INSERTS

CQEE 40
16 A 500 V

Crimp connection

EN 61984 rating	16 A 500 V 6 kV 3
Rated voltage (UL / CSA)	500 V
Insulation resistance	≥ 10 GΩ
Contact resistance	≤ 1 mΩ
Ambient temperature limit	-40 °C ... +125 °C
Mechanical life (cycles)	≥ 500

CE CB CB

ECBT2.E115072 | ECBT8.E115072

size **77.27**
40 poles + ⊕

Item **Description** **Part No.** **Dimension**

Male inserts for male contacts (to be ordered separately) **CQEEM 40**

Female inserts for female contacts (to be ordered separately) **CQEEF 40**

16 A advanced opening contacts

section (mm²)	section (AWG)
0,5	20
0,75	18
1	18
1,5	16
2,5	14

16 A crimp contacts

section (mm²)	section (AWG)
0,14-0,37	26-22
0,5	20
0,75	18
1	18
1,5	16
2,5	14
3	12
4	12

Male **Female**

silver

CC 0.5 AN	CCFA 0.3
CC 0.7 AN	CCFA 0.5
CC 1.0 AN	CCFA 0.7
CC 1.5 AN	CCFA 1.0
CC 2.5 AN	CCFA 1.5
CC 3.0 AN	CCFA 2.5
CC 4.0 AN	CCFA 3.0

silver

CCMA 0.3	CCFA 0.3
CCMA 0.5	CCFA 0.5
CCMA 0.7	CCFA 0.7
CCMA 1.0	CCFA 1.0
CCMA 1.5	CCFA 1.5
CCMA 2.5	CCFA 2.5
CCMA 3.0	CCFA 3.0
CCMA 4.0	CCFA 4.0

gold

CCMD 0.3	CCFD 0.3
CCMD 0.5	CCFD 0.5
CCMD 0.7	CCFD 0.7
CCMD 1.0	CCFD 1.0
CCMD 1.5	CCFD 1.5
CCMD 2.5	CCFD 2.5
CCMD 3.0	CCFD 3.0
CCMD 4.0	CCFD 4.0

Wiring information, CC contacts

conductor section (mm²)	conductor slot e A (mm)	stripping length (mm)
0,14-0,37	0,9	7,5
0,5	1,1	7,5
0,75	1,3	7,5
1,0	1,45	7,5
1,5	1,8	7,5
2,5	2,2	7,5
3,0	2,55	7,5
4,0	2,85	7,5

Wire diameter: up to 4,7 mm.
For basic or high thickness gold plating, please refer to page F.13.
It is recommended to use the crimping tools and removal tools homologated by ILME (please see page F.23)

Materials

insert	polycarbonate (PC)
UL 94 flame rating	V-0
Colour	pebble grey, RAL 7032
Contacts	copper alloy, silver ◻ and gold ◻ plated

CR CPQ
Coding pins
Page G.3

Enclosures size 77.27 **Pages**

Heavy-Duty Applications

Metallic with C-TYPE lever	E. 62-69
Metallic with IL-BRID lever	E. 96-99, 106
Metallic with JEI®-P lever	E. 115-116, 119
Metallic with V-TYPE IP67 lever	E. 126, 132-133
Thermoplastic T-TYPE	E. 230-231, 234-235

Aggressive Environments

Metallic IP68 high protection	E. 146-147
Metallic W-TYPE	E. 158-159, 164
Metallic E-Xtreme®	E. 178-179, 186-187, 196
Thermoplastic T-TYPE/W	E. 230-231, 234-235

Specialized Applications

EMC (Electromagnetic Shielding)	E. 212-213, 218
Hygienic series for food and beverage	E. 246, 248
Standard applications with Central lever	E. 258-259
BIG Enclosures for multiple cable entries	E. 270, 276-277
COB system for switch cabinet	E. 286-289
Light and Sound applications with JEI®-P lever	E. 300-301

6

CQEE 40 inserts max. current load derating diagram

B.78 dimensions shown in mm are not binding and may be changed without notice

SECTIONS, INDEXES, CONTENTS

The **11 sections** are listed in the **Main index**. Each section owns its **Figurative sub-index** for a direct consultation.

Main index

GENERAL CATALOGUE	
Contents	
INTRODUCTION	
Compact 21.21 inserts and enclosures	
Standard inserts	
MM3 modular inserts	
PCB adapters for inserts	
Enclosures	
Crimp contacts, Tools	
Accessories	
HMN - High Number of Mating cycles connectors series	
180 °C High Temperatures connectors series	
APPENDIX	

11 sections

GENERAL CATALOGUE	
Standard inserts	
Contents	
32.10 inserts	B.14
32.15 inserts	B.14
32.16 inserts	B.14
32.17 inserts	B.14
32.18 inserts	B.14
32.19 inserts	B.14
32.20 inserts	B.14
32.21 inserts	B.14
32.22 inserts	B.14
32.23 inserts	B.14
32.24 inserts	B.14
32.25 inserts	B.14
32.26 inserts	B.14
32.27 inserts	B.14
32.28 inserts	B.14
32.29 inserts	B.14
32.30 inserts	B.14
32.31 inserts	B.14
32.32 inserts	B.14
32.33 inserts	B.14
32.34 inserts	B.14
32.35 inserts	B.14
32.36 inserts	B.14
32.37 inserts	B.14
32.38 inserts	B.14
32.39 inserts	B.14
32.40 inserts	B.14
32.41 inserts	B.14
32.42 inserts	B.14
32.43 inserts	B.14
32.44 inserts	B.14
32.45 inserts	B.14
32.46 inserts	B.14
32.47 inserts	B.14
32.48 inserts	B.14
32.49 inserts	B.14
32.50 inserts	B.14
32.51 inserts	B.14
32.52 inserts	B.14
32.53 inserts	B.14
32.54 inserts	B.14
32.55 inserts	B.14
32.56 inserts	B.14
32.57 inserts	B.14
32.58 inserts	B.14
32.59 inserts	B.14
32.60 inserts	B.14
32.61 inserts	B.14
32.62 inserts	B.14
32.63 inserts	B.14
32.64 inserts	B.14
32.65 inserts	B.14
32.66 inserts	B.14
32.67 inserts	B.14
32.68 inserts	B.14
32.69 inserts	B.14
32.70 inserts	B.14
32.71 inserts	B.14
32.72 inserts	B.14
32.73 inserts	B.14
32.74 inserts	B.14
32.75 inserts	B.14
32.76 inserts	B.14
32.77 inserts	B.14
32.78 inserts	B.14
32.79 inserts	B.14
32.80 inserts	B.14
32.81 inserts	B.14
32.82 inserts	B.14
32.83 inserts	B.14
32.84 inserts	B.14
32.85 inserts	B.14
32.86 inserts	B.14
32.87 inserts	B.14
32.88 inserts	B.14
32.89 inserts	B.14
32.90 inserts	B.14
32.91 inserts	B.14
32.92 inserts	B.14
32.93 inserts	B.14
32.94 inserts	B.14
32.95 inserts	B.14
32.96 inserts	B.14
32.97 inserts	B.14
32.98 inserts	B.14
32.99 inserts	B.14
32.100 inserts	B.14

Figurative sub-index

The figurative sub-index, that opens each section, clearly shows the series of products relevant to each product line.

Product introduction page

COEY - AXYR® series
Connection without tools. High contacts density.

COEY series overview

The 16-A range of connector inserts using the AXYR® tool-less technology is further advanced by the new COEY series, interoperable with the corresponding available models of COE series (series).

The AXYR® technology can equal the crimp connectors versions in terms of high density without requiring any crimping tool.

TECHNOLOGY AT A GLANCE

Just insert the wire into the contact hole and crimp!

The crimping process starts from the wire.

FOCUS

Inserts technology

The AXYR® 16-A tool-less spring push-in contacts cover a wiring range: 0.25 mm to 2.5 mm (AWG 24-14) for prepreg wires, 0.25 mm to 4 mm (AWG 24-12) for unprepreg wires.

The performance of a mixed COEY / COE coupling is equivalent to that of an equivalent crimped COEY / COEY (COEY) coupling where both sides are wired with the consent of the wire sizes used by the mixed coupling.

The inserts of AXYR® series COEY are available in standard and double-insert hole for COE series.

COEY connector inserts allow additional coding of the mating hole by means of CR CODE coding pins, that must be fitted in the dedicated devoted shaped seats on the contour of the mating face in specific pattern.

- Required pins to correctly code a coupling:
 - + 1 pins for 10 and 18 poles connectors
 - + 4 pins for 32, 45, 64 and 90 poles connectors
- CR CODE optional plastic coding pins for up to 6 configurations

Technical pages

COEY 10
16 A 500 V
10 poles + 0

Tool-less connection - AXYR®

Item	Description	Part No.	Dimension
1	Header assembly with crimp contacts	COEY 10	
2	Spring pin with punch in connection	COEY 10	
3	Header assembly with crimp contacts	COEY 10	
4	Spring pin with punch in connection	COEY 10	

Requirements

Requirement	Value
Wire diameter	0.25 mm (AWG 24-14)
Wire length	2.5 mm (AWG 24-14)
Wire type	Unprepreg (AWG 24-12)
Wire color	Any color
Wire temperature	Up to 100 °C

CR CODE
Coding pins

Dimensions in mm

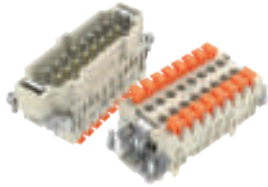
COEY 10 inserts max. current load carrying diagram

Each sub-index includes a **Product introduction page**, providing a general overview, followed by the relevant **Technical pages**.



AXYR[®] tool-less connection

40 A MIXO modules
and
35 A CPY inserts



SQUICH[®] tool-less connection

inserts for Type J
thermocouples



MIXO fibre optic

LC data
module



MIXO PE

module for thermoplastic
docking frames



Size 21.21 enclosures

with new rigid
levers design



Size 32.13 CQ insert

for 40 A contacts
up to 10 mm²



IP68 high protection

size 21.21
covers



BIG enclosures

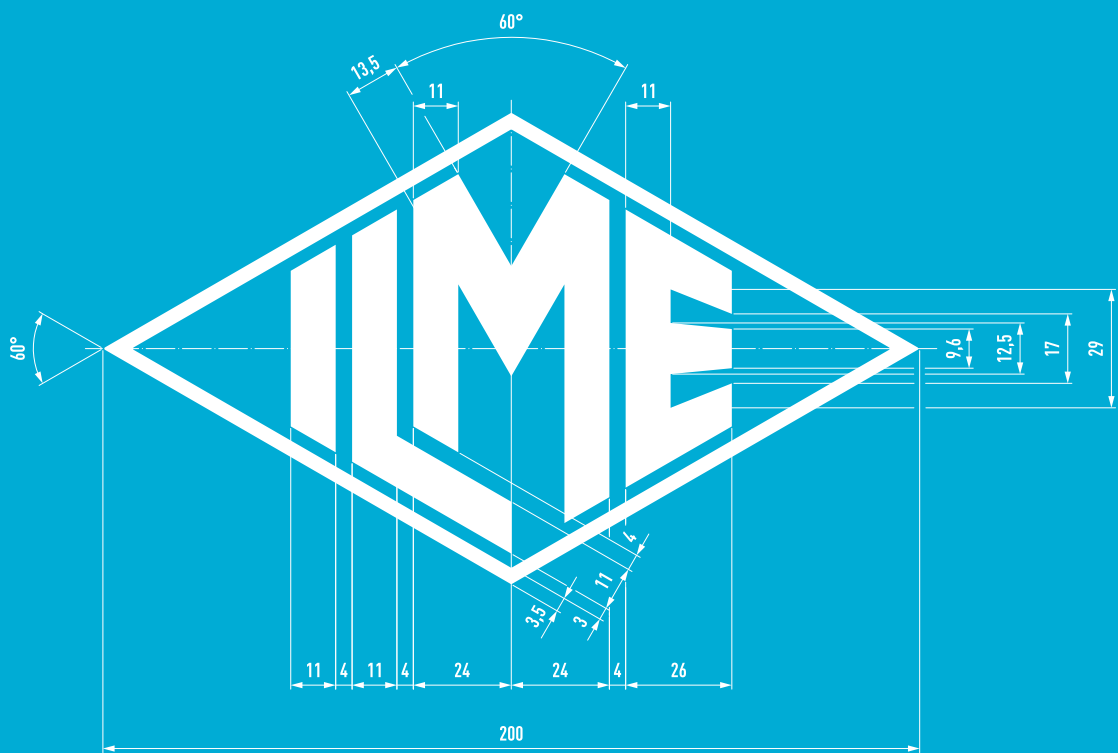
with integrated
floating frames



GENERAL CATALOGUE

Contents









INTRODUCTION	INTRO
Compact 21.21 inserts and enclosures	A
Standard inserts	B
MIXO modular inserts	C
PCB adapters for inserts	D
Enclosures	E
Crimp contacts, Tools	F
Accessories	G
HNM - High Number of Mating cycles connectors series	H
180 °C High Temperatures connectors series	I
APPENDIX	J



GENERAL CATALOGUE

Introduction

Contents

	Important notes	<i>INTRO.02</i>
	CE marking	<i>INTRO.03</i>
	Multipole connectors general features	<i>INTRO.04</i>
	Combinations between enclosures and inserts	<i>INTRO.06</i>
	Inserts termination technologies	<i>INTRO.08</i>
	SCREW	
	SPRING	<i>INTRO.10</i>
	SQUICH® - Tool-less	<i>INTRO.12</i>
	AXYR® - Tool-less	<i>INTRO.14</i>
	CRIMP	<i>INTRO.16</i>
Contacts	Crimp contacts overview	<i>INTRO.18</i>
		
Inserts	Technical features	<i>INTRO.22</i>
		
Enclosures	Locking systems	<i>INTRO.34</i>
	Hoods / Housings	<i>INTRO.36</i>
	Housings, hoods, and covers selection guide	<i>INTRO.48</i>
	Technical features	<i>INTRO.52</i>
	www.ilme.com	<i>INTRO.58</i>

IMPORTANT NOTES

- 1 ILME designs and manufactures complete solutions for Heavy Duty electrical power connections.
The connector (although offered to the user as a variety of elements, usually inserts and enclosures, to allow the selection of the ideal combination) has been **designed as a complete connector** and tested to be compliant with the essential safety requirements of the EU Low Voltage Directive 2014/35/EU and in particular the EN 61984 standard. The design of this “whole” system guarantees that every allowed combination of inserts, enclosures and accessories cannot result as improper.
- 2 The products in this catalogue alone cannot guarantee the best functionality upon installation, as this depends also on their correct **“putting into service”** which must be performed in compliance with the applicable system safety standards and according to the “rule of the art”. Therefore the effectiveness of the installation of the connector depends on the choices of the end user who must also take into account the following safety requirements.
- 3 Connectors must **not be connected or disconnected when live or under load**.
- 4 After wiring the inserts it is necessary **to verify the continuity of the protective earth connections**.
- 5 The **correct coupling of the inserts** is guaranteed only if they are installed (with the four fixing screws supplied *) inside the corresponding enclosures or onto compatible accessories in this catalogue. ILME S.p.A. is not responsible for any different application.
- 6 Wiring of **screw-type terminal connections** must be carried out applying the correct tightening torque in order to avoid false contacts or damage to the conductor, the screw or the terminal.
- 7 **Crimping tools** and **crimp contacts** used should preferably be supplied by the same manufacturer to avoid difficulties with the insertion and retention or damaging of the contacts themselves.
- 8 Correct wiring of **spring-clamp connection inserts** is guaranteed only when the correct screwdriver indicated in the specific catalogue, or possibly on the insert, is used **.
- 9 Avoid forcing the contacts during **connection and disconnection**. Connectors must be coupled and uncoupled in the axial direction with respect to the contacts, without bending and pulling the attached conductor bundles or cables.
- 10 Installation of two **inserts side by side**, in enclosures with two bays, must respect the polarity drawing marked on the insert (or the contact side view, as shown in this catalogue) to avoid inverted coupling.
- 11 Installation of two or more identical **connectors side by side** is recommended only with the use of **coding pins** in order to avoid mismatched couplings.
- 12 In order to keep the declared **degree of protection** (IP code according to EN 60529, or Enclosure Type Rating according to ANSI/UL 50E), enclosures must be completed with cable glands and/or other accessories with at least an equal degree of protection.
- 13 Moreover, the declared **degree of protection** (IP code according to EN 60529, or Enclosure Type Rating according to ANSI/UL 50E) is guaranteed when the enclosures, complete with inserts, are coupled and locked with their locking levers (or devices).
- 14 Connector inserts and their enclosures are generally compatible with similar/equivalent products from other manufacturers, according to the last samples tested. Full compatibility cannot be guaranteed in the event of technical changes made by other manufacturers. In particular, maximum performance of IP68 enclosures (CG-MG, CGK-MGK series) cannot be guaranteed when coupled with other manufacturers' products.
- 15 **Spare parts** are supplied in minimum quantities only with the purpose to replace damaged parts on ILME products. Any custom combination/use of ILME spare parts disrespectful of this restriction, renders the CE marking no longer valid and any ILME safety liability on that use null and void.. To avoid invalidation of warranty, products should be modified or repaired only by ILME: the integrity of their functionality - e.g. their degree of protection - can no longer be guaranteed if products are modified/repared by end-users. In any case, the liability for correct choice, assembly and use is totally at charge of the installer and the end-user.
- 16 ILME S.p.A. takes no responsibility in verifying whether the components herein contained comply with any specific regulations of fields of application.
- 17 ILME cannot be held responsible for individual components in **uses other than those described in this catalogue**.
ILME cannot be held responsible for **incorrect connector selection** in relation to the environmental conditions of the application (e.g.: influence of ambient temperature, moisture, environmental pollution, etc.).

* Except one fixing screw for size “21.21” inserts, two fixing screws for size “32.13” inserts.

** Except for **SQUICH®** inserts (with spring-clamp terminals with actuator button) and **AXYR®** inserts (push-in spring terminals with actuator button) that do not require any tool to operate the terminal.

CE MARKING

As from 1st January 1997, in order to make available electrical products on the European market, the manufacturer must ensure that these bear the relevant **CE marking**, in line with the Low Voltage Directive 73/23/EEC* (implemented in Italy as L. D. 18-10-1977 no. 791) and its modification 93/68/EEC* (implemented in Italy as L.D. 25-11-1996 no. 626/96, published in the supplement to the Gazzetta Ufficiale of 14-12-1996).

The CE marking must be visible on the product or, if this is not possible, on the packaging, the instructions for use or on the warranty certificate. It acts as a declaration by the manufacturer that the product complies with all relevant EU directives regarding its field of application.

ILME products bear the CE marking on the actual product or its packaging.

Almost all ILME products fall within the scope of the Low Voltage Directive. An EU declaration of conformity is required in order to be able to apply the CE marking. This declaration, to which the market is not directly entitled, must be made available to the controlling authorities (in Italy, the Ministry of Economic Development) at all times. In it, the manufacturer declares the technical safety standard(s) followed in the design and manufacture of the product. These standards must be, in decreasing order of preference:

- a European standard (EN prefix)
- a European harmonisation document (HD prefix)
- an IEC International Standard
- a national standard
- in the absence of reference safety standards, the manufacturer's internal specifications guaranteeing compliance with the basic safety requirements of the directive.

Conformity with harmonised technical standards (i.e. ratified by CENELEC) also constitutes presumption of conformity with the basic safety requirements of the directives.

The CE marking of ILME products results from the declaration of conformity of the product to harmonised standards or IEC International Standards.

Through the CE marking, ILME declares full compliance, not merely with the directive's basic safety requirements, but also with those international or national standards on which voluntary safety certification markings are based (e.g. IMQ and VDE). In this way, ILME intends to give the CE marking the value of self-certification in terms of safety, given the loss in legal value of voluntary certifications issued by third parties, ratified by directive 93/68/EEC*.

Notwithstanding the above, practically all ILME products still bear voluntary conformity markings.

The above mentioned EU declaration of conformity becomes null and void when the assembly of products includes one or more components not manufactured by ILME and without CE marking.

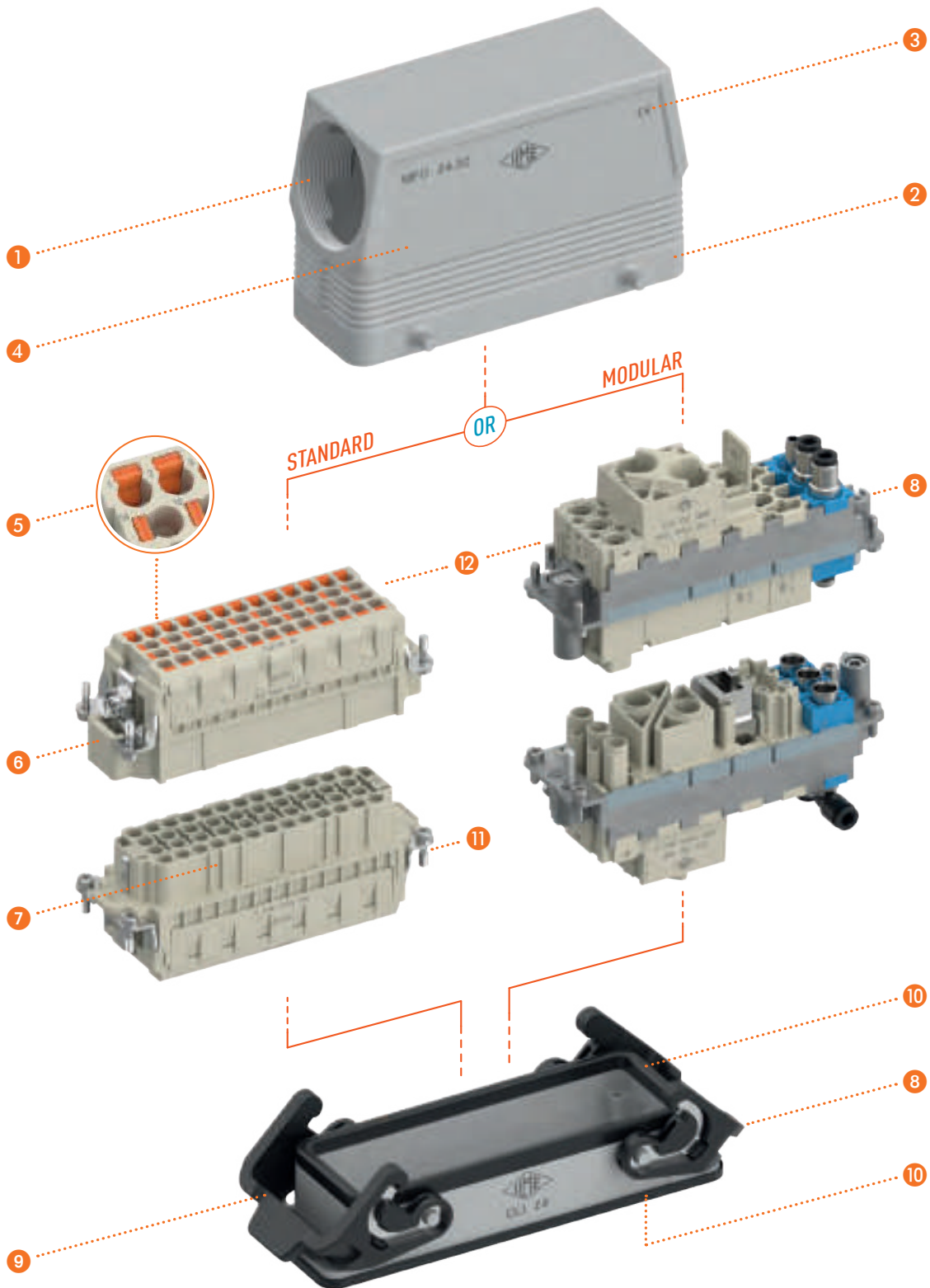
The information contained in this catalogue is not binding and may be changed without notice.

* **Note:** The subsequent legal reference for the Low Voltage Directive was 2006/95/EC, as consolidation of the original Directive 73/23/EEC + Directive 93/68/EEC. On 29th March 2014, the Official Journal of the European Union published the new Low Voltage directive 2014/35/EU dd. 26th February 2014, a recast version of directive 2006/95/EC, which is in force since 20th April 2016.

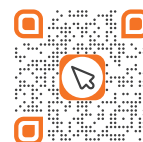


Design, manufacture and distribution
of industrial electrical equipment (IAF 19)
Certificate No. 50 100 11133

MULTIPOLE CONNECTORS GENERAL FEATURES



- 1 **Threaded cable entry** in various metric thread sizes (types with pre-code "M") in accordance with EN 60423, for cable entry devices in accordance with EN 62444, or Pg thread sizes (types with pre-code "C") (NPT threading on request). May be located vertically, horizontally or frontally.
- 2 Rugged die-cast metal enclosures (die-cast **aluminium or zinc alloy**) and **self-extinguishing thermoplastic resin** enclosures, cULus approved. Surface-mounting, bulkhead, and hood versions are available, with or without hinged or detached protection covers. Standard size enclosures have an internal coding key that prevents the insertion of high voltage inserts series CME (all) and CMCE (only 16+2 poles), while CM (Pg) enclosures series and MM (metric) have no such coding key and contain supplementary insulating strips inside for 830 V inserts.
- 3 **CE marking**, laser-marked on both inserts and enclosures, attesting conformity to the requirements of the Low Voltage Directive (2014/35/EU).
- 4 Metallic enclosures with epoxy-polyester **thermosetting powder coating** (or epoxy coating for harsh environment applications) with high resistance to mechanical stress and external agents. Specific enclosures with no paint coating are available for use at temperatures up to 180 °C or for EMC purposes.
- 5 **The contact position** is identified with numbers or codes on both sides of each insert, laser-marked or printed by mould.
- 6 **Inserts** are made of UL-certified self-extinguishing fibreglass-reinforced thermoplastics and feature an operating temperature range between -40 °C and +125 °C. The inserts CME (all) and CMCE (only 16+2 poles) for 830 V have a key that prevents the insertion of inserts for use other than that prescribed (types CM-Pg and MM-metric). For some series, inserts in PPS (polyphenylene sulphide) are available for specific uses with temperatures of up to 180 °C.
- 7 Insert **polarised profiles** with asymmetrical guides to avoid incorrect matings. Inserts have a mechanical life equal to or higher than:
 - 500 mating cycles when equipped with silver plated or gold plated contacts;
 - 200 mating cycles when equipped with tin plated contacts.
- 8 Inserts and enclosures are manufactured in compliance with European standard **EN 61984** (DIN VDE 0627), certified and identified with **UL** (cULus or UL) and **CSA** marks (the CSA mark not for all series).
- 9 **Locking levers** are available in self-extinguishing thermoplastic material, or stainless steel or a combination of both materials, suitable for each application requirement, guaranteeing a perfect closure and tight sealing. Single or double locking, with one or two levers.
- 10 Special **sealing gaskets** in vinyl nitrile elastomer, polyurethane or fluoroelastomer (on R-TYPE enclosures for use with maximum temperatures of 180 °C, on W-TYPE enclosures for aggressive environments and on E-Xtreme® enclosures for ultimate resistance to corrosion and erosion), anti-aging, oil-resistant, fuel-resistant, together with the cable entry devices (not supplied) provide a degree of protection (IP code per EN IEC 60529 and Enclosure Type Rating per ANSI/UL 50E) for coupled connectors. Special conductive sealing gaskets for S-TYPE EMC enclosures.
- 11 Captive insert **fastening screws**, with anti-loosening spring washer or under-head knurling.
- 12 Standard inserts or MIXO modular inserts with dedicated termination technology, tool-less **SQUICH®** and **AXYR®** spring, screw and crimp. Protective ⊕ terminals with a wide contact surface are clearly marked on each insert or MIXO modular frame.



Find more
information on
our products at
www.ilme.com

COMBINATIONS BETWEEN ENCLOSURES AND INSERTS







Identification of enclosures

Connector inserts and their enclosures are numerous, and finding the correct pairing of one with another may be complex.

To facilitate this operation (in addition to each distinctive part number), the definition of "size" has been introduced in this catalogue.

The "size" value refers to the X - Y fixing screw centre distance which constitutes a unique and shared element between inserts (standard and modular) and enclosures.



Table 1 - Standard inserts / enclosure size reference

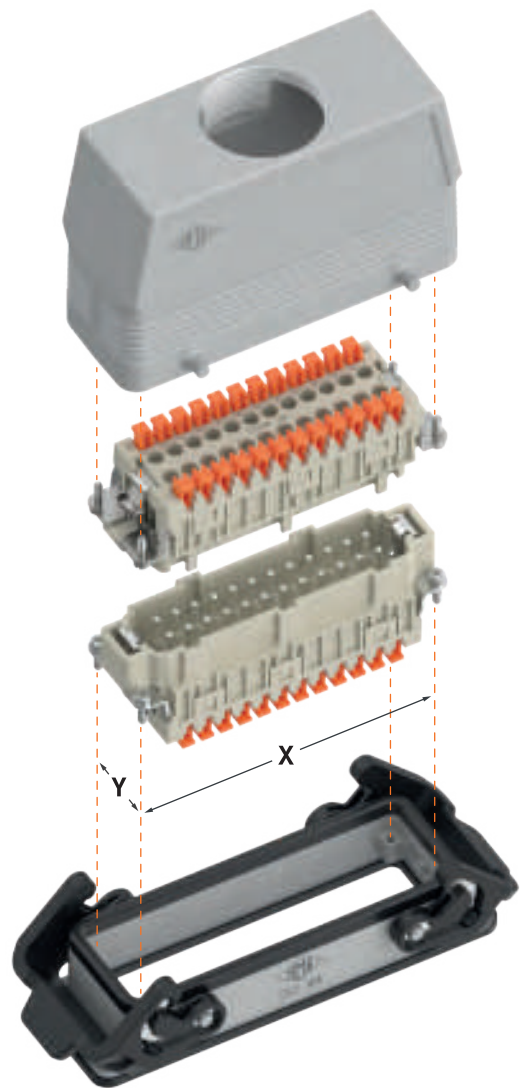
Enclosures identifications#	Enclosures size X - Y	Insert X - Y fixing screw centre distance
03	21.21	(21 × 21 mm)*
08	32.13	32 × 13 mm
15	49.16	49,5 × 16 mm
25	66.16	66 × 16 mm
50 	66.40 	66 × 16 mm (2 inserts)
06	44.27	44 × 27 mm
10	57.27	57 × 27 mm
16	77.27	77,5 × 27 mm
24	104.27	104 × 27 mm
32 	77.62 	77,5 × 27 mm (2 inserts)
48 	104.62 	104 × 27 mm (2 inserts)


The value in this column depicts the historical identification of each enclosure dimension according to the closest compatible insert's polarity (e.g., CLI 06 L with CNEM 06 T).


* Due to the single fixing screw of 21.21 inserts, the size is identified by the insert's cross-sectional dimensions.

Table 2 - Modular inserts / enclosure size reference

Modular frame slot identification	Enclosures size X - Y	Modular frame X - Y fixing screw centre distance
01	49.16	49,5 × 16 mm
02	44.27	44 × 27 mm
03	57.27	57 × 27 mm
04	77.27	77,5 × 27 mm
06	104.27	104 × 27 mm
04 (x2)	77.62 	77,5 × 27 mm (2 inserts)
06 (x2)	104.62 	104 × 27 mm (2 inserts)



 These sizes belong to enclosures for double insert.

 All pages that illustrate combinable articles (inserts and enclosures) carry references as per the examples illustrated on the opposite page.

Enclosures identifications#	Enclosures size X - Y	Rated current											
		300 A	100 A	40 A	35 A	16 A	16 A	16 A	16 A	16 A	10 A	10 A 6,5 A	10 A
		200 A	80 A	16 A									
		100 A	40 A	10 A									
		70 A	16 A	6,5 A									
		40 A											
		16 A											
		10 A											
		5 A											
		4 A											
Inserts series*													
		MIXO MIXO RX (HNM)	CX - CXC RX - RXC (HNM)	CQ4 CQ - CQY RQ (HNM)	CP - CPY	CQE - CQY CQEE RQE - RQEE (HNM)	CNE - CCE CSH - JSH-S - CSHT RSH - RCC (HNM)	CDA - CDC CSAH	CT - CTS CT - CTSE CSS	CMCE CMSH	CD - CDY CDD RD - RDD (HNM)	CDSH CDSH NC RDSH (HNM)	CK - CKSH
Inserts polarity + ⊕													
03	21.21			2 3 5 7 12 21							7 8 ▲		3 4
08	32.13			4 8 17									
15	49.16	①*						10			15		
25	66.16							16			25 (CD) 38 (CDD)		
50 (×2)	66.40	⊙						32			50 (CD) 76 (CDD)		
06	44.27	②*				10	6 ●		6 ■		24 (CD)	6 (CDSH NC) 9	
10	57.27	③*	8/24			18	10		10 ■	3	40 (CD) 42 (CDD)	18	
16	77.27	④*	4/0 4/2 12/12 9/42 6/12 6/36		6	32	16		16 ■ 40 ■	6	64 (CD) 72 (CDD)	27	
24	104.27	⑥*	8/0 6/6 4/8			46	24		24 ■ 64 ■	10	108 (CDD)	42	
32 (×2)	77.62	⊙			12	64	32 ●		32 ■	12	80 (CD) 144 (CDD)	54	
48 (×2)	104.62	⊙				92	48 ●		48 ■	20	128 (CD) 216 (CDD)	84	

The value in this column depicts the historical identification of each enclosure dimension according to the closest compatible insert's polarity (e.g., CLI 06 L with CNEM 06 T).

- * Number of single modular inserts that may be inserted in the enclosures.
- * High temperature RY inserts available.
- Except CSHT inserts series.
- ▲ Polarity without protective ⊕ contact.
- ⊙ These sizes belong to enclosures for double insert.
- Can only be mounted in bulkhead housings.

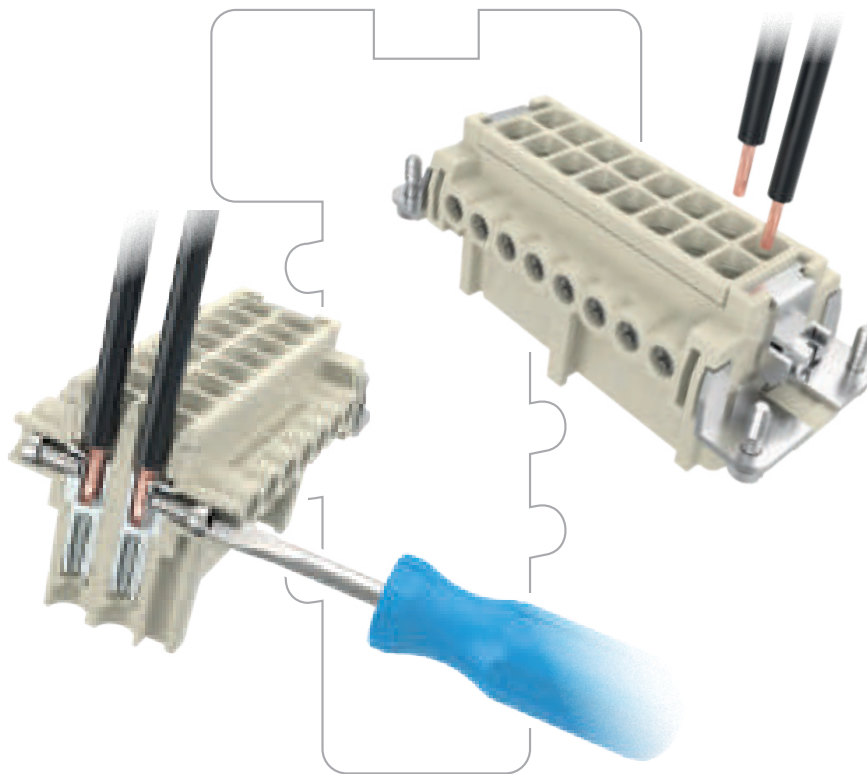
INSERTS TERMINATION TECHNOLOGIES

SCREW

The classic connection

Screw-type inserts represent one of the oldest and widely used connection technologies in the electrical industry. The connections of the conductors to the female and male inserts are made via screws (in conformance with standard EN 60999-1). Screw-type inserts offer a reusable connection for solid and stranded wires either prepared (crimped with insulated or non-insulated wire ferrule of suitable size) or unprepared.

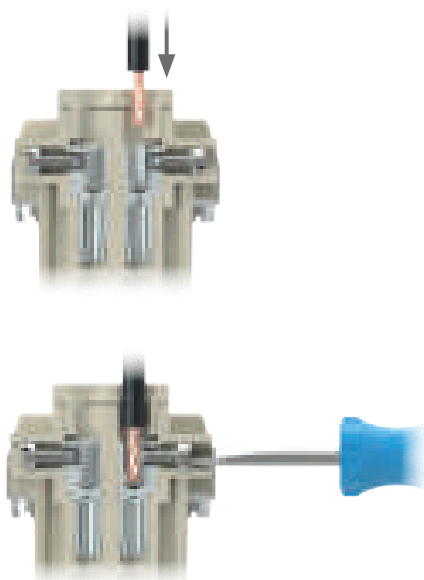
Requiring common and popular tools, like a flat blade screwdriver or a Ph cross-headed screwdriver (see reference page J.2 for recommended tightening torque), the only downside of screw-type connectors is the low resistance to vibration, resulting in a loose connection when the conductor is not adequately secured.



KEY ADVANTAGES

- > Easy assembly and operation, reusable connection.
- > Wide product range: from 10 A to 80 A nominal current and from 0,75 mm² to 16 mm² conductor cross-section (according to the specific insert).
- > Silver or gold-plated contacts.
- > High temperature version (RY) available for use in applications with up to 180 °C ambient temperature.

WIRING

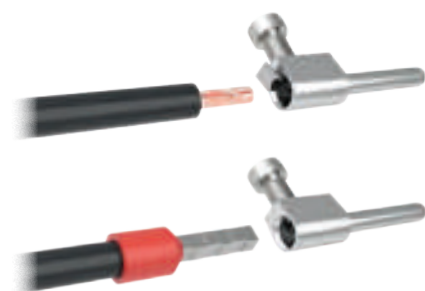


Screw-type terminal connectors feature a cone-shaped terminal cavity to guide the conductor inside the terminal seat securely, stainless steel protection plate for the use of unprepared conductors and galvanized steel terminal screws. All terminals are presented completely open (unscrewed) and ready to be wired.

A standard screwdriver (Ph or flat type; see reference page J.2 for recommended tightening torque) is used to secure the conductor by tightening the terminal screw. The PE terminal is also screw-type and is located on the mounting bracket on pole #1. It covers the same conductor cross-sectional area range as the line terminals.

For all inserts with screw-type terminals it is important that the right torque is applied to the terminal screws in order to prevent wrong contact or damage to the conductor, the screw or the terminal.

CLAMPING TYPES

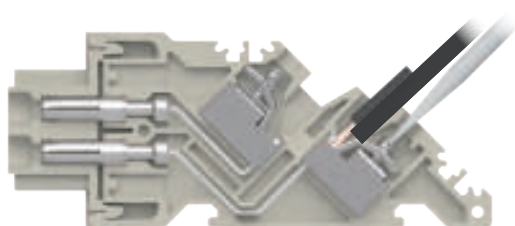


Screw-type connectors series come in two main variants:

- > With pressure (protection) plate, for unprepared conductors, to preserve conductor strands from being cut from the screw head.
- > Without pressure (protection) plate, for prepared conductors (crimped with insulated or non-insulated wire ferrule of suitable size).

☑ The highest conductor cross-sectional area can be used only with unprepared conductors.

BUILT-IN TERMINAL BLOCK



CT series: in this layout, the wires are connected to the female and male insert contacts using a screw for all CT inserts (in compliance with EN 60999-1).

The inserts contain:

- > A terminal block at 45° for fixed installation on electrical panels or built-in DIN EN 60715 rail for easier wire cabling and identification operations.
- > Screw connection with pressure plate which does not require the wires to be prepared (CT inserts).

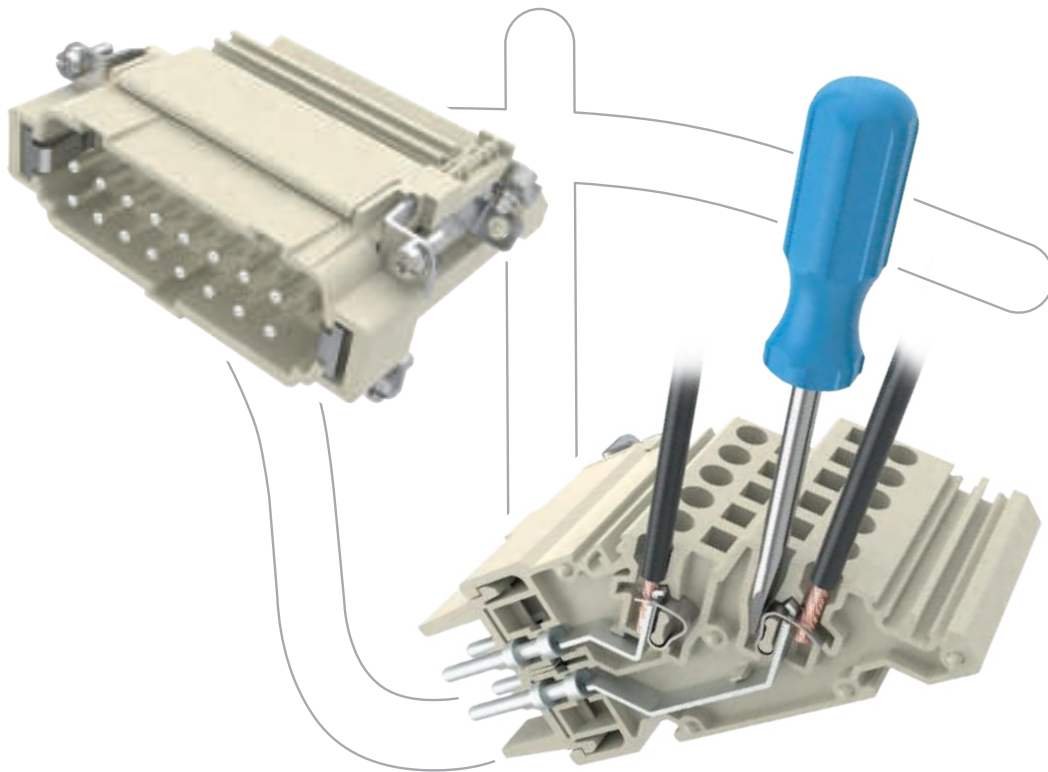
INSERTS TERMINATION TECHNOLOGIES

SPRING

Cage-shaped clamp trap

Spring-type inserts feature a cage-shaped spring clamp to secure each conductor to the contact terminals, granting a stable and vibration-proof connection. The terminal springs must be opened using a suitable flat screwdriver to accommodate the selected stripped wire; once the insertion

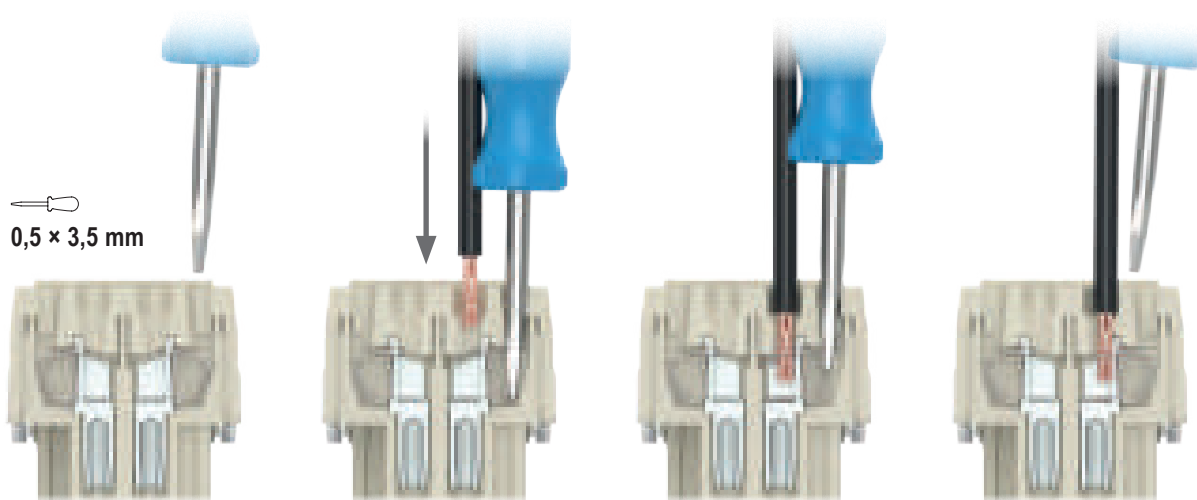
is complete, the spring retains the conductor. Spring clamp connections are described in the international standard IEC 60352-7, particularly the electrical and mechanical characteristics each connection must endure, as the tensile strength and contact resistance requirements.



KEY ADVANTAGES

- > Vibration proof connection.
- > Cost and time effective connection: easy wiring.
- > Compatible with solid or stranded conductors, no special wire preparation needed.
- > Compatibility with corresponding screw-type, crimp and SQUICH® inserts (CCE, CNE, CSH series).

WIRING



0,5 x 3,5 mm

Step 1

Insert the flat blade screwdriver tip in the dedicated square-shaped cavity outside the terminal and push it perpendicularly to the access surface, up to the bottom. Acting as a wedge, the screwdriver tip pushes the spring forward to open the wire-clamping window.

Step 2

Insert the wire previously stripped and twisted at the right length all the way down in the round terminal cavity.

Step 3

Remove the screwdriver tip. The spring clamps now the wire in the terminal.

Step 4

Pull gently on the wire to ensure that it is firmly clamped in the spring terminal.

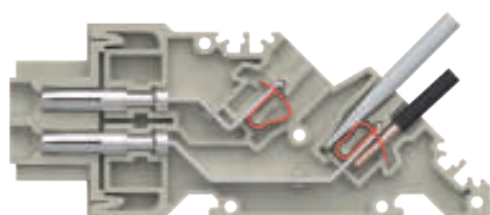
DUAL SPRING TERMINAL



CSS Connector series

Equipped with two spring terminals per contact, the insert is designed for a circuit to be branched off. Series CSS inserts share the mating interface (dimensions) with equally sized inserts of series CNE (screw-type), CCE (crimp-type), CSH (spring-type with actuator button SQUICH®), CT (screw-type with 45° terminal block) and CTSE (spring type with 45° terminal block). They are ideal as motor connectors, connecting motor windings in star and delta configurations.

BUILT-IN TERMINAL BLOCK



CTS-CTSE Connector series

With terminal block at 45° built-in for fixed installation on electrical panels or on built-in DIN EN 60715 rail for easier wire cabling and identification operations.

Spring terminal connection, which does not require a wire preparation (CTSE inserts).

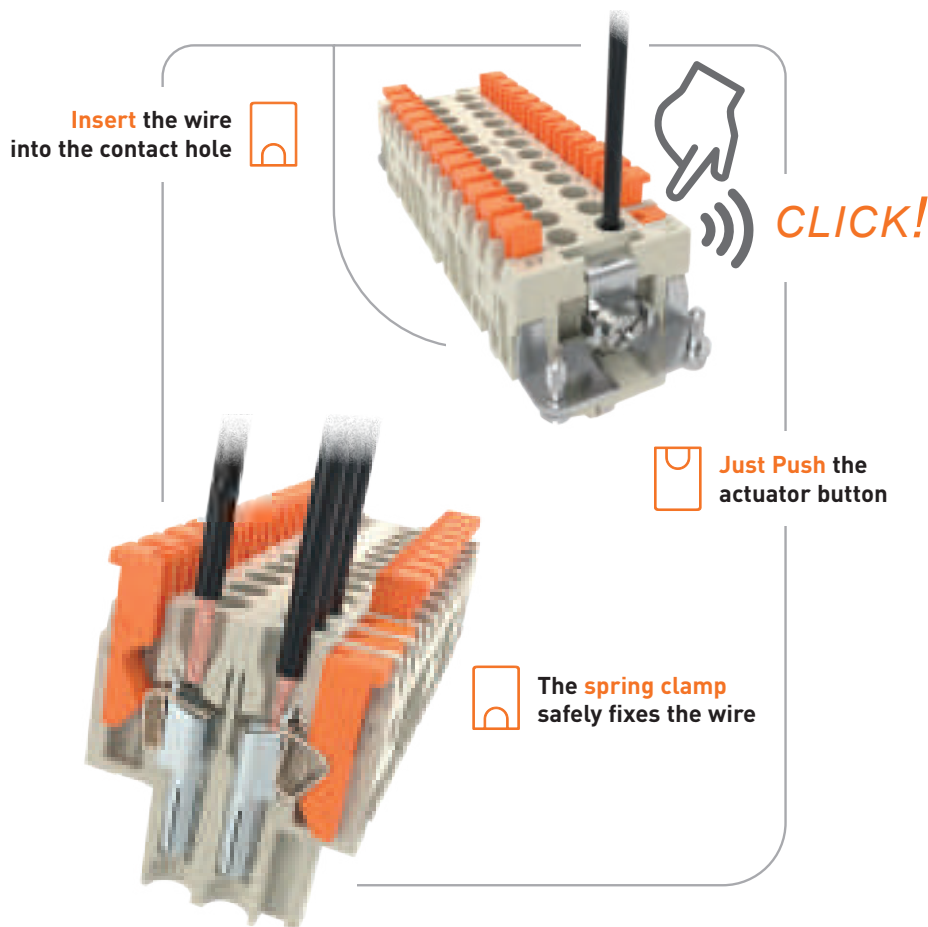
INSERTS TERMINATION TECHNOLOGIES

SQUICH®

Tool-less connection, Just Push

The cornerstone of ILME R&D activity focusing on easy installation and safe wiring gets its pioneering example in the SQUICH® technology. Based on well-known and proven spring technology, SQUICH® allows tool-less connection **at the push of a button**, while providing all the advantages

of traditional springs, such as resistance to temperature changes, shock and vibration. Compatible with flexible, prepared or solid wire, any application benefits from a safe and reliable electrical connection.



KEY ADVANTAGES

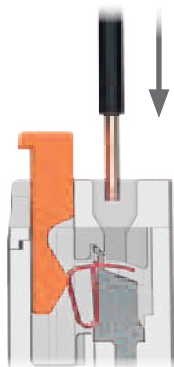
- > No special wire preparation, other than stripping.
- > No need for wiring tools.
- > Excellent fastening solution and great resistance to strong vibrations.
- > Reduced wiring time, up to 50%.
- > Suitable for solid and flexible wires, both prepared and unprepared, with a cross sectional area range of 0,14 mm² to 2,5 mm².
- > Correct wiring can be checked by inserting a test probe into the probing slot of the actuator buttons.

Watch our
Video

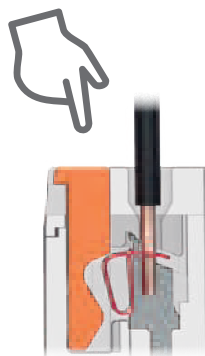


WIRING

The wires are connected to the insert contacts by a spring terminal with **patented actuator button**.

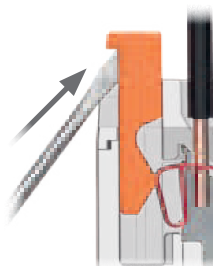


- > Deeply insert the wire into the contact hole previously stripped and twisted



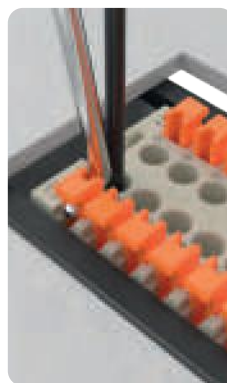
- > Push the actuator button to close the spring terminal

RE-OPENING with screwdriver



- > Insert a **0,5 × 3,5 mm flat blade screwdriver** in the actuator button side window and pull it up by levering down to release the wire from the spring clamp

RE-OPENING with CSHES



CSHES allows the release of the connection from a SQUICH® terminal without disassembling the connector from the bulkhead mounting housing.

Not suitable for CKSH and CX 05 SH, whose re-opening can be done with a flat blade screwdriver.

PROBING SLOT



- > **Easy to access** probing slot on buttons for measuring devices, even with mounted connector.

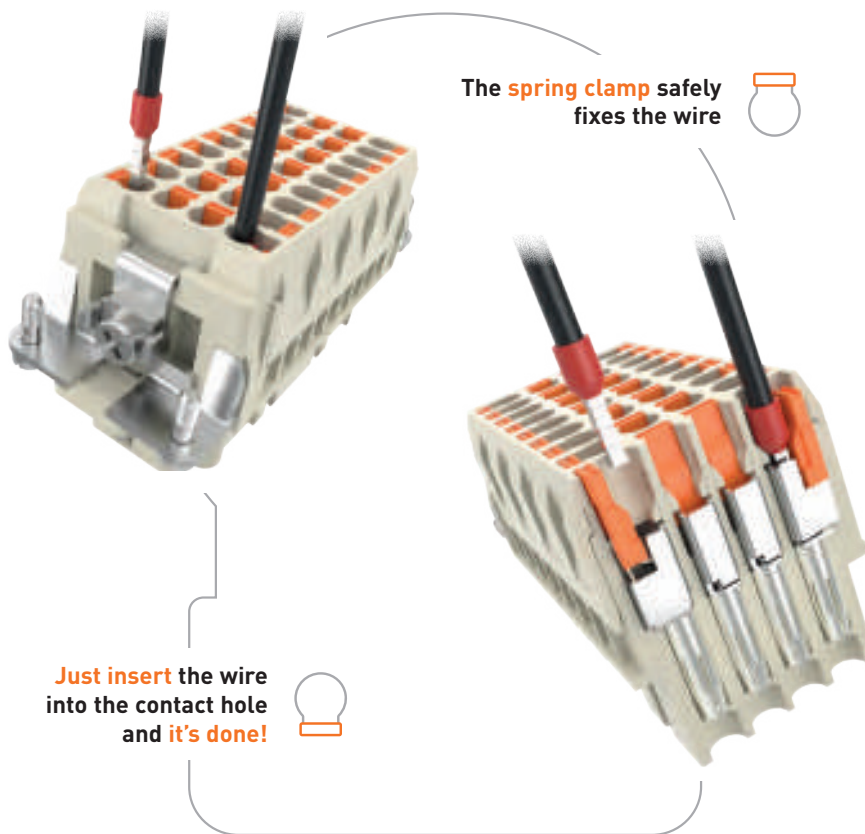
INSERTS TERMINATION TECHNOLOGIES

AXYR®

Tool-less, high-density & fast connection

AXYR® is the new rapid connection technology developed by ILME to optimize work times and methods, enabling industries of all sectors to reach their automation targets more effectively. An **extremely compact push-in spring termination** which equals crimp connectors in high density,

therefore guaranteeing an equivalent electrical performance. Wiring in axis is the formula that recaps the technology strong point as it enables **straightforward tool-less wiring**. Operations require one simple step: wire insertion.



KEY ADVANTAGES

- > **High density tool-less connection.** Compatible with corresponding crimp connectors. No need for any crimping tool.
- > **Easy and fast.** Easy wiring by the actuator buttons. Suitable for any wire: solid and stranded, either end-sleeve prepared or unprepared.
- > **Safe.** Spring clamp connection resistant to mechanical stress and vibrations.
- > AXYR® features an harmonic steel spring and a tiny, yet stiff, properly designed actuator button working together to allow a **simple push-in action** guaranteeing a safe wiring.
- > Wire release with a **simple** flat-blade screwdriver.
- > **Machined** brass contacts.
- > Thanks to a **boxed terminal**, the wire contact pressure does not rely upon surrounding insulating parts, likely to possibly relax under heating when the connector is under current load.

Watch our
Video



WIRING simple push-in action

Solid or Prepared wires:
Cross-sectional Area $\geq 0,75 \text{ mm}^2$ / 18 AWG



1

Deeply insert the solid or prepared wire into the contact hole



2

The wire is safely secured by the spring clamp




WIRING with flat-blade screwdriver

Stranded wires: All Cross-sectional Areas
Solid or Prepared wires: Cross-sectional Area $< 0,75 \text{ mm}^2$ / 18 AWG



1

Push down the actuator button by a flat-blade screwdriver

-  0,5 × 3 mm max. for 10 A
-  0,5 × 3,5 mm max. for 16 A
-  0,8 × 4,5 mm max. for 40 A

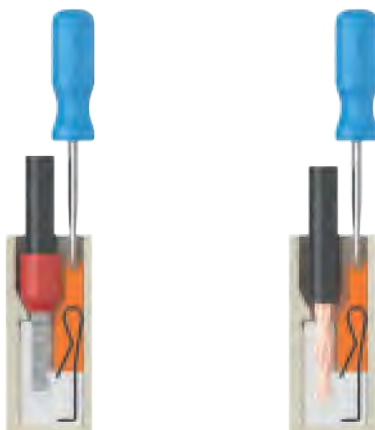
insert the stranded wire, previously stripped and twisted, into the contact hole, or the solid or prepared wire of small size



2




The wire is safely secured by the spring clamp

RE-OPENING



R

Push down the actuator button by a flat-blade screwdriver to remove the wire:

-  0,5 × 3 mm max. for 10 A
-  0,5 × 3,5 mm max. for 16 A
-  0,8 × 4,5 mm max. for 40 A

INSERTS TERMINATION TECHNOLOGIES

CRIMP

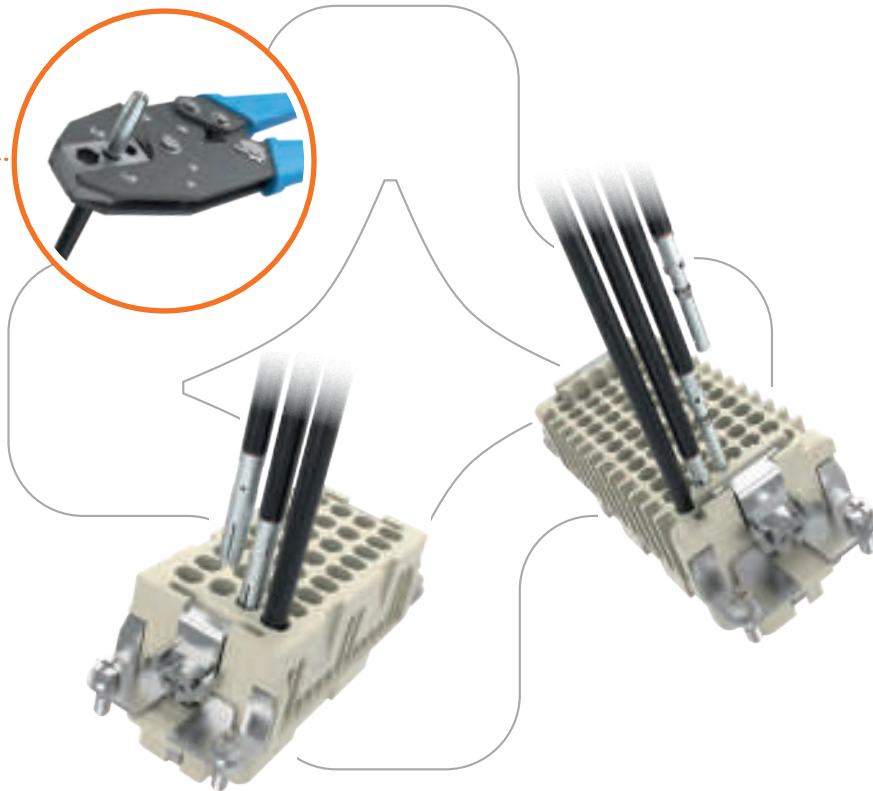
Compact, space-saving & high-density connection

The crimp connection is an irreversible, non-reusable connection between one or two conductors and a crimp contact. It is obtained by **compression deformation** (cold forming) and consequent reshaping of the contact crimping stem or crimp barrel.

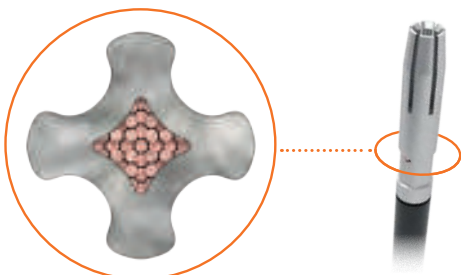
A good crimp connection is provided by a suitable combination between the **crimping dies**, the **contact** crimp barrel (hence the crimp contact), and the cross-section of the conductor.

The crimped connections for wire sections up to 10 mm² are covered by the EN 60352-2:2006 European standard equivalent to the IEC 60352-2 Issue 2 (2006-02) international standard.

For cross-sectional areas higher than 10 mm², up to 70 mm² the reference standard has been the **NF F 61-030:1989** French standard until its withdrawal in favour of **EN 50467:2011**, which relates to electrical connectors on board railway rolling stock.



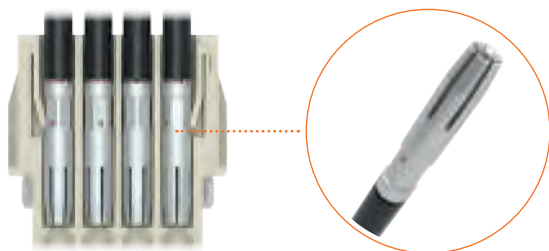
Crimped contact cross section



KEY ADVANTAGES

- > Lower voltage drop across the connection.
- > High stability in time even in the presence of vibrations.
- > High durability in presence of corrosion (gas-tightness).
- > High-density connection.

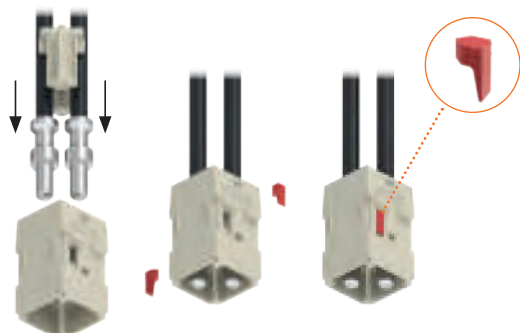
CRIMP INSERTS with retention device inside insert



Once crimped with the right combination of the crimping tool and locator, the crimp contacts series CI (5 A), CC (16 A), CX (40 A), and CX7 (80 A and 70 A) are securely held in place inside each insert by using a specifically designed contact holder.

Each contact entry is tapered to facilitate wire insertion and avoid any damage after the crimping operation.

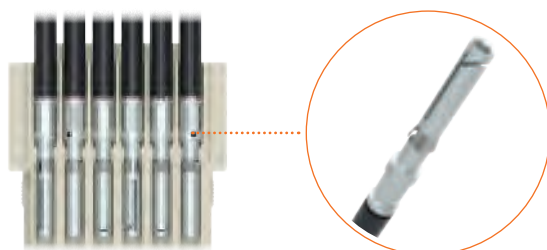
CRIMP INSERTS with retention device



High-power crimp contacts for standard inserts and MIXO modules, series CG (100 A), CY (200 A), and C30 (300 A), are securely held in place inside each insert by red-coloured locking tabs.

This innovative design, patented by ILME, does not require removal tools to extract the crimped contacts.

CRIMP INSERTS with retention device on contacts



Contacts series CD (10 A) features an elastic retention element directly on the contact body. The CD series compatible inserts don't require a specific contact holder.

Once crimped with the right combination of the crimping tool and locator, the contacts are inserted inside the inserts.

INSERTION AND REMOVAL TOOLS



For safe removal of the contacts from the inserts (for inspection or re-wiring), it's crucial to use ILME's specific removal tools. These tools are designed to prevent inappropriate removal of the contacts, thereby preserving the integrity of the retaining system and ensuring the safety of the connection.

Specific insertion tools are also available where small wire cross-section wires don't allow a simple contact insertion (see Chapter G- for removal and insertion tools).

CRIMP CONTACTS OVERVIEW

ILME crimp contacts are available in silver or gold-plated versions (contacts above 70 A are silver-plated only).

Gold-plated crimp contacts are recommended for applications with low-rated currents and low-rated voltages.

Thanks to the electrical characteristics of gold, signal deterioration is prevented, and excellent resistance to the surface oxidation of the contacts is achieved. In particular, gold-plated contacts are recommended with signals with less than ± 5 mA current and ± 5 V voltage.

Rated current	Plating	Wire cross-section									
		mm ²	120	95	70	50	35	25	16	10	
		AWG	4/0	3/0	2/0	1	2	4	6	8	
300 A	silver plated		C30MA 120 P C30MA 120 C30FA 120	C30MA 95 P C30MA 95 C30FA 95	C30MA 70 P C30MA 70 C30FA 70	C30MA 50 P C30MA 50 C30FA 50	C30MA 35 P C30MA 35 C30FA 35	C30MA 25 P C30MA 25 C30FA 25	C30MA 16 P C30MA 16 C30FA 16		
200 A				CYMA 70 CYFA 70	CYMA 50 CYFA 50	CYMA 35 CYFA 35	CYMA 25 CYFA 25	CYMA 16 CYFA 16			
100 A						CGMA 35 CGFA 35	CGMA 25 CGFA 25	CGMA 16 CGFA 16	CGMA 10 CGFA 10		
80 A / 70 A							CX7MA 25 P CX7MA 25 CX7FA 25	CX7MA 16 P* CX7MA 16* CX7FA 16*	CX7MA 10 P CX7MA 10 CX7FA 10		
40 A										CXMA 10 CXFA 10	
16 A ²⁾											
10 A											
6,5 / 5 / 4 A ¹⁾											
16 A		gold plated									
10 A											
6,5 / 5 / 4 A ¹⁾											
80 A / 70 A	HNM						RX7M2D 25 P RX7M2D 25 RX7F2D 25	RX7M2D 16 P* RX7M2D 16* RX7F2D 16*	RX7M2D 10 P RX7M2D 10 RX7F2D 10		
40 A									RXM2D 10 RXF2D 10		
16 A											
10 A											
6,5 / 5 / 4 A ¹⁾											

¹⁾ Please check each insert derating diagram to establish the actual maximum operating current according to the ambient temperature.

²⁾ CC series, 16 A male contacts also available in advanced opening version (see codes CC..AN).

* RX7 and CX7 series contacts also available for extra-flexible Class 6 conductors (for 16 mm² - AWG 6 wire cross-section only).

Standard ILME gold treatment is carried out in accordance with MIL-G-45204C Class 00, Type II, Grade C and ASTM B488-01 Class 0.5, Type II, Grade C. The basic or high-thickness gold-plated contacts comply with EN 61984: 2009, IEC 60512, and EN 60352-2:1994 (same as the standard version).

ILME crimp contacts are compatible with flexible copper conductors of class 5 (flexible) or 6 (more flexible than class 5), according to EN IEC 60228.



Please refer to Section F for additional information regarding ILME crimp contacts series.

Rated current	Plating	Wire cross-section										
		mm ²	6	4	3	2,5	1,5	1	0,75	0,5	0,14-0,37	0,08-0,21
		AWG	10	12	12	14	16	18	18	20	26-22	28-24
300 A	silver plated											
200 A												
100 A												
80 A / 70 A		CX7MA 6.0 P CX7MA 6.0 CX7FA 6.0										
40 A		CXMA 6.0 CXFA 6.0	CXMA 4.0 CXFA 4.0		CXMA 2.5 CXFA 2.5	CXMA 1.5 CXFA 1.5						
16 A ²⁾			CCMA 4.0 CCFA 4.0	CCMA 3.0 CCFA 3.0	CCMA 2.5 CCFA 2.5	CCMA 1.5 CCFA 1.5	CCMA 1.0 CCFA 1.0	CCMA 0.7 CCFA 0.7	CCMA 0.5 CCFA 0.5	CCMA 0.3 CCFA 0.3		
10 A					CDMA 2.5 CDFA 2.5	CDMA 1.5 CDFA 1.5	CDMA 1.0 CDFA 1.0	CDMA 0.7 CDFA 0.7	CDMA 0.5 CDFA 0.5	CDMA 0.3 CDFA 0.3		
6,5 / 5 / 4 A ¹⁾								CIMA 0.7 CIFA 0.7	CIMA 0.5 CIFA 0.5	CIMA 0.3 CIFA 0.3	CIMA 0.2 CIFA 0.2	
16 A	gold plated		CCMD 4.0 CCFD 4.0	CCMD 3.0 CCFD 3.0	CCMD 2.5 CCFD 2.5	CCMD 1.5 CCFD 1.5	CCMD 1.0 CCFD 1.0	CCMD 0.7 CCFD 0.7	CCMD 0.5 CCFD 0.5	CCMD 0.3 CCFD 0.3		
10 A				CDMD 2.5 CDFD 2.5	CDMD 1.5 CDFD 1.5	CDMD 1.0 CDFD 1.0	CDMD 0.7 CDFD 0.7	CDMD 0.5 CDFD 0.5	CDMD 0.3 CDFD 0.3			
6,5 / 5 / 4 A ¹⁾								CIMD 0.7 CIFD 0.7	CIMD 0.5 CIFD 0.5	CIMD 0.3 CIFD 0.3	CIMD 0.2 CIFD 0.2	
80 A / 70 A	HNM	RX7M2D 6.0 P RX7M2D 6.0 RX7F2D 6.0										
40 A		RXM2D 6.0 RXF2D 6.0	RXM2D 4.0 RXF2D 4.0		RXM2D 2.5 RXF2D 2.5	RXM2D 1.5 RXF2D 1.5						
16 A			RCM2D 4.0 RCF2D 4.0	RCM2D 3.0 RCF2D 3.0	RCM2D 2.5 RCF2D 2.5	RCM2D 1.5 RCF2D 1.5	RCM2D 1.0 RCF2D 1.0	RCM2D 0.7 RCF2D 0.7	RCM2D 0.5 RCF2D 0.5	RCM2D 0.3 RCF2D 0.3		
10 A					RDM2D 2.5 RDF2D 2.5	RDM2D 1.5 RDF2D 1.5	RDM2D 1.0 RDF2D 1.0	RDM2D 0.7 RDF2D 0.7	RDM2D 0.5 RDF2D 0.5	RDM2D 0.3 RDF2D 0.3		
6,5 / 5 / 4 A ¹⁾								RIMD 0.7 RIFD 0.7	RIMD 0.5 RIFD 0.5	RIMD 0.3 RIFD 0.3	RIMD 0.2 RIFD 0.2	

SD series 10 A stamped crimp contacts

Stamped, 10 A open crimp barrel contacts without insulation grip for stranded copper wires.




Available with silver plating in one performance level (PL1) for up to 500 mating cycles, either as loose-part contacts or in 5,000-piece reels.

			Loose contacts (200 pcs. per box package)	Reel package (5 000 pcs. in large-sized reel)
				
Rated current	Wire cross-section	Performance level (PL)	Packaging	
10 A	0,37-1 mm ² AWG 24-18	PL1 ≥ 500 cycles	SDFA 1.0 SDMA 1.0	SDFA 1.0R SDMA 1.0R
	1,5-2,5 mm ² AWG 16-14		SDFA 2.5 SDMA 2.5	SDFA 2.5R SDMA 2.5R

SI series 5 A stamped crimp contacts

Stamped, 5 A open crimp barrel contacts with insulation grip for stranded copper wires.

Available with different selective gold plating thickness (over nickel) according to three required performance levels: PL1 – PL2 – PL3, respectively for 500, 250 and 50 mating cycles.

			Loose contacts (200 pcs. per box package)	Coil package (500 pcs. in compact-sized coil)	Reel package (10 000 pcs. in large-sized reel)
					
Rated current	Wire cross-section	Performance level (PL)	Packaging		
5 A	0,21-0,52 mm ² AWG 24-20	PL1 ≥ 500 cycles	SIM1D 0.2 SIF1D 0.2	SIM1D 0.2C SIF1D 0.2C	SIM1D 0.2R SIF1D 0.2R
		PL2* ≥ 250 cycles	SIM2D 0.2 SIF2D 0.2	SIM2D 0.2C SIF2D 0.2C	SIM2D 0.2R SIF2D 0.2R
		PL3 ≥ 50 cycles	SIM3D 0.2 SIF3D 0.2	SIM3D 0.2C SIF3D 0.2C	SIM3D 0.2R SIF3D 0.2R
5 A	0,08-0,21 mm ² AWG 28-24	PL1 ≥ 500 cycles	SIM1D 0.5 SIF1D 0.5	SIM1D 0.5C SIF1D 0.5C	SIM1D 0.5R SIF1D 0.5R
		PL2* ≥ 250 cycles	SIM2D 0.5 SIF2D 0.5	SIM2D 0.5C SIF2D 0.5C	SIM2D 0.5R SIF2D 0.5R
		PL3 ≥ 50 cycles	SIM3D 0.5 SIF3D 0.5	SIM3D 0.5C SIF3D 0.5C	SIM3D 0.5R SIF3D 0.5R



* PL2 available on stock; PL1 and PL3 available upon request.



INSERTS FEATURES

21.21 SIZE INSERTS

SECTION A

Inserts series	No. of poles		Rated current ¹⁾	EN 61984 (2009-06) pollution degree 3			EN 61984 (2009-06) pollution degree 2			UL / CSA certification	Conductor connection technology
	Contacts			Rated voltage	Rated impulse voltage	Pollution degree	Rated voltage	Rated impulse voltage	Pollution degree	Rated voltage AC or DC	
	Main + PE	Aux.									
CQ4 02 H	2	—	40 A	830 V	6 kV	3	—	—	—	600 V	Crimp
CQ4 02	2	—	40 A	400 V	6 kV	3	—	—	—	600 V	Crimp
CQ4 03	3	—	40 A	400 V	6 kV	3	—	—	—	600 V	Crimp
CQ4 03/2	3	—	40 A	400 V	6 kV	3	—	—	—	600 V	Crimp
	—	2	10 A	250 V	4 kV	3	—	—	—	600 V	
CQ 05	5	—	16 A	230 / 400 V	4 kV	3	320 / 500 V	4 kV	2	600 V	Crimp
CQY 05	5	—	16 A	230 / 400 V	4 kV	3	—	—	—	600 V	AXYR® Spring
CQ 07	7	—	10 A	400 V	6 kV	3	—	—	—	600 V	Crimp
CQ 12	12	—	10 A	400 V	6 kV	3	400 / 690 V	6kV	2	600 V	Crimp
CQ 21	21 (without PE)	—	6,5 A	50 V _{AC} / 120 V _{DC}	0,8 kV	3	—	—	—	250 V	Crimp
CK	3, 4	—	10 A	230 / 400 V	4 kV	3	400 / 690 V	4 kV	2	600 V	Screw
JK	3, 4	—	10 A	400 V	4 kV	3	400 / 690 V	4 kV	2	600 V	Screw
CKD	3, 4	—	10 A	230 / 400 V	4 kV	3	400 / 690 V	4 kV	2	600 V	Screw
CKSH	3, 4	—	10 A	400 V	4 kV	3	690 V	4 kV	2	600 V	SQUICH® Spring
CD 	7	—	10 A	250 V	4 kV	3	230 / 400 V	4 kV	2	600 V	Crimp
CDY 	7	—	10 A	250 V	4 kV	3	230 / 400 V	4 kV	2	600 V	AXYR® Spring
CD	8 (without PE)	—	10 A	50 V _{AC} / 120 V _{DC}	0,8 kV	3	—	—	—	50 V _{AC} / 120 V _{DC}	Crimp
CDY	8 (without PE)	—	10 A	50 V _{AC} / 120 V _{DC}	0,8 kV	3	—	—	—	50 V _{AC} / 120 V _{DC}	AXYR® Spring

 All inserts with built-in contacts are provided with **silver plated contacts**, unless otherwise specified.

1) Please check the insert derating diagrams to establish the actual maximum operating current according to the ambient temperature.

 **CD 07 and CDY 07:** IP67 with thermoplastic enclosures (cannot be used with metal enclosures).

21.21 SIZE DATA INSERTS SECTION A


Inserts series	No. of poles		Rated current ¹⁾	EN 61984 (2009-06) pollution degree 3			EN 61984 (2009-06) pollution degree 2			UL / CSA certification	Conductor connection technology
	Contacts			Rated voltage	Rated impulse voltage	Pollution degree	Rated voltage	Rated impulse voltage	Pollution degree	Rated voltage AC or DC	
Main + PE	Aux.										
CJ K	1 RJ45 Cat. 5	—	2,1 A	35 V _{AC} / 50 V _{DC}	—	—	—	—	—	35 V _{AC} / 50 V _{DC}	Crimp
CJK 8..T	1 RJ45 Cat. 6 _A	—	1 A	50 V	0,8 kV	3	—	—	—	50 V	Crimp
CJK 8I..T	1 RJ45 Cat. 6 _A	—	1 A	50 V	0,8 kV	3	—	—	—	50 V	IDC
CJK 8M	1 RJ45	—	—	for 1 RJ45 Cat. 6 _A Class E _A or 1 RJ45 Cat. 6 _A							—
CUK 2FT	1 USB 2.0	—	—	—	—	—	—	—	—	—	—
CUK 3FT	1 USB 3.0	—	—	—	—	—	—	—	—	—	—
CX 1/2 BD	1 CX 01 B/BC (1 pole)	—	10,16 A	50 V	0,8 kV	3	—	—	—	50 V	Crimp
	1 CX 04 B (4 poles)	—	10 A	50 V	0,8 kV	3	—	—	—	50 V	
	1 CX 08 B (8 poles)	—	4 A	50 V	0,8 kV	3	—	—	—	50 V	
	—	2	10 A	50 V	0,8 kV	3	—	—	—	50 V	
CLK 04	4 (seats/poles)	—	—	contacts for glass fibre 50 / 125 µm or 62,5 / 125 µm or for 1 mm Ø POF							Crimp

¹⁾ Please check the insert derating diagrams to establish the actual maximum operating current according to the ambient temperature.

32.13 SIZE INSERTS

SECTION B



Inserts series	No. of poles		Rated current ¹⁾	EN 61984 (2009-06) pollution degree 3			EN 61984 (2009-06) pollution degree 2			UL / CSA certification	Conductor connection technology
	Contacts			Rated voltage	Rated impulse voltage	Pollution degree	Rated voltage	Rated impulse voltage	Pollution degree	Rated voltage AC or DC	
Main + PE	Aux.										
CQ 04/2E	4	—	40 A	400 / 690 V	6 kV	3	—	—	—	600 V	Crimp
	—	2	10 A	250 V	4 kV	3	—	—	—	600 V	
CQ 04/2	4	—	40 A	400 / 690 V	6 kV	3	—	—	—	600 V	Crimp
	—	2	10 A	250 V	4 kV	3	—	—	—	600 V	
CQ 04/2B	4	—	40 A	400 / 690 V	6 kV	3	—	—	—	600 V	Crimp
	—	2	10 A	250 V	4 kV	3	—	—	—	600 V	
CQ 08E	8	—	16 A	500 V	6 kV	3	400 / 690 V	8 kV	2	600 V	Crimp
CQY 08E	8	—	16 A	500 V	6 kV	3	400 / 690 V	8 kV	2	600 V	AXYR [®] Spring
CQ 08	8	—	16 A	500 V	6 kV	3	400 / 690 V	8 kV	2	600 V	Crimp
CQ 17	17	—	10 A	160 V	2,5 kV	3	250 V	4 kV	2	600 V	Crimp

 All inserts with built-in contacts are provided with **silver plated contacts**, unless otherwise specified.


¹⁾ Please check the insert derating diagrams to establish the actual maximum operating current according to the ambient temperature.

SLIM SIZE INSERTS

SECTION B




Inserts series	No. of poles		Rated current ²⁾	EN 61984 (2009-06) pollution degree 3			EN 61984 (2009-06) pollution degree 2			UL / CSA certification	Conductor connection technology	
	Contacts			Rated voltage	Rated impulse voltage	Pollution degree	Rated voltage	Rated impulse voltage	Pollution degree	Rated voltage AC or DC		
	Main + PE ¹⁾	Aux.										
CDA	10, 16, (32)		—	16 A	250 V	4 kV	3	230 / 400 V	4 kV	2	600 V	Screw
CDC	10, 16, (32)		—	16 A	250 V	4 kV	3	230 / 400 V	4 kV	2	600 V	Crimp
CSAH	10, 16, (32)		—	16 A	250 V	4 kV	3	400 V	4 kV	2	600 V	SQUICH® Spring
CD 	15, 25, (50)		—	10 A	250 V	4 kV	3	230 / 400 V	4 kV	2	600 V	Crimp
CDD 	38, (76)		—	10 A	—	—	—	250 V	4 kV	2	600 V	Crimp


 All inserts with built-in contacts are provided with **silver plated contacts**, unless otherwise specified.

- 1) Number of poles shown in brackets may be achieved by using two inserts.
- 2) Please check the insert derating diagrams to establish the actual maximum operating current according to the ambient temperature.
-  Contacts partially fitted inside an insert allow inserts to be used for applications requiring rated voltages higher than those shown. See **CD** and **CDD** inserts relevant tables.

STANDARD SIZE INSERTS


SECTION B

Inserts series	No. of poles		Rated current ²⁾	EN 61984 (2009-06) pollution degree 3			EN 61984 (2009-06) pollution degree 2			UL / CSA certification	Conductor connection technology
	Contacts			Rated voltage	Rated impulse voltage	Pollution degree	Rated voltage	Rated impulse voltage	Pollution degree	Rated voltage AC or DC	
	Main + PE ¹⁾	Aux.									
CNE	6, 10, 16, (32), 24, (48)	—	16 A	500 V	6 kV	3	400 / 690 V	6 kV	2	600 V	Screw
CCE	6, 10, 16, (32), 24, (48)	—	16 A	500 V	6 kV	3	400 / 690 V	6 kV	2	600 V	Crimp
CSH	6, 10, 16, (32), 24, (48)	—	16 A	500 V	6 kV	3	400 / 690 V	6 kV	2	600 V	SQUICH® Spring
JSH-S	6, 10, 16, (32), 24, (48)	—	16 A	500 V	6 kV	3	—	—	—	600 V	SQUICH® Spring
CSHT	10, 16, 24	—	16 A	500 V	6 kV	3	—	—	—	600 V	SQUICH® Spring
CQE 	10, 18, 32, (64), 46, (92)	—	16 A	500 V	6 kV	3	830 V	8 kV	2	600 V	Crimp
CQEY	10, 18, 32, (64), 46, (92)	—	16 A	500 V	6 kV	3	830 V	8 kV	2	600 V	AXYR® Spring
CQEE	40, 64	—	16 A	500 V	6 kV	3	—	—	—	600 V	Crimp
CD 	40, (80), 64, (128)	—	10 A	250 V	4 kV	3	230 / 400 V	4 kV	2	600 V	Crimp
CDD 	24, 42, 72, (144), 108, (216)	—	10 A	—	—	—	250 V	4 kV	2	600 V	Crimp
CDSH	9, 18, 27, (54), 42, (84)	—	10 A	400 V	6 kV	3	400 / 690 V	6 kV	2	600 V	SQUICH® Spring
CDSH NC	6 – AutoShort NC	—	6,5 A	250 V	4 kV	3	500 V	4 kV	2	600 V	SQUICH® Spring
CP	6, (12)	—	35 A	400 / 690 V	6 kV	3	—	—	—	600 V	Screw
CPY	6, (12)	—	35 A	400 / 690 V	6 kV	3	—	—	—	600 V	AXYR® Spring
CT	6, 10, 16, 24	—	16 A	230 / 400 V	4 kV	3	400 V	4 kV	2	600 V	Screw 45° terminal block
CTSE	6, 10, 16, (32), 24, (48)	—	16 A	500 V	6 kV	3	400 / 690 V	6 kV	2	600 V	Spring 45° terminal block
CT	40, 64	—	10 A	250 V	4 kV	3	230 / 400 V	4 kV	2	600 V	Screw 45° terminal block
CTS	40, 64	—	10 A	250 V	4 kV	3	230 / 400 V	4 kV	2	600 V	Spring 45° terminal block
CSS	6, 10, 16, (32), 24, (48)	—	16 A	500 V	6 kV	3	400 / 690 V	6 kV	2	600 V	Spring
CMCE	3, 6, (12), 10, (20)	—	16 A	830 V	8 kV	3	1000 V	8 kV	2	600 V	Crimp
	3, 6, (12), 10, (20)	—	16 A	830 V	8 kV	3	720 / 1250 V	8 kV	2	600 V	
	—	2, (4)	16 A	500 V	6 kV	3	—	—	—	600 V	
CMSH	3, 6, (12), 10, (20)	—	16 A	830 V	8 kV	3	1000 V	8 kV	2	600 V	SQUICH® Spring
	3, 6, (12), 10, (20)	—	16 A	830 V	8 kV	3	720 / 1250 V	8 kV	2	600 V	
	—	2, (4)	16 A	500 V	6 kV	3	—	—	—	600 V	

 All inserts with built-in contacts are provided with **silver plated contacts**, unless otherwise specified.

1) Number of poles shown in brackets may be achieved by using two inserts.

2) Please check the insert derating diagrams to establish the actual maximum operating current according to the ambient temperature.

 Contacts partially fitted inside an insert allow inserts to be used for applications requiring rated voltages higher than those shown. See **CD, CDD and CQE** inserts relevant tables.

COMBINED INSERTS

SECTION B

Inserts series	No. of poles		Rated current ¹⁾	EN 61984 (2009-06) pollution degree 3			EN 61984 (2009-06) pollution degree 2			UL / CSA certification	Conductor connection technology
	Contacts			Rated voltage	Rated impulse voltage	Pollution degree	Rated voltage	Rated impulse voltage	Pollution degree	Rated voltage AC or DC	
	Main + PE	Aux.									
CX 8/0	8	—	100 A	690 V	8 kV	3	—	—	—	600 V	Crimp
CX 6/6	6	—	100 A	690 V	8 kV	3	—	—	—	600 V	Crimp
	—	6	16 A	400 V	6 kV	3	—	—	—	600 V	
CX 4/0	4	—	80 A	830 V	8 kV	3	—	—	—	600 V	Screw
CX 4/2	4	—	80 A	830 V	8 kV	3	—	—	—	600 V	Screw
	—	2	16 A	400 V	6 kV	3	400 / 690 V	6 kV	2	600 V	
CXC 4/2	4	—	80 A	830 V	8 kV	3	—	—	—	600 V	Crimp
	—	2	16 A	400 V	6 kV	3	—	—	—	600 V	
CX 4/8	4	—	80 A	400 V	6 kV	3	400 / 690 V	6 kV	2	600 V	Screw
	—	8	16 A	230 / 400 V	4 kV	3	400 V	4 kV	2	600 V	
CXC 4/8	4	—	80 A	400 V	6 kV	3	—	—	—	600 V	Crimp
	—	8	16 A	230 / 400 V	4 kV	3	—	—	—	600 V	
CX 12/2	12	—	40 A	690 V	8 kV	3	—	—	—	600 V	Crimp
	—	2	10 A	250 V	4 kV	3	—	—	—	600 V	
CX 6/12	6	—	40 A	690 V	8 kV	3	—	—	—	600 V	Crimp
	—	12	10 A	230 / 400 V	4 kV	3	—	—	—	600 V	
CX 9/42	9	—	40 A	690 V	8 kV	3	—	—	—	600 V	Crimp
	—	42	10 A	250 V	4 kV	3	—	—	—	600 V	
CX 6/36	6	—	40 A	690 V	8 kV	3	—	—	—	600 V	Crimp
	—	36	10 A	160 V	2,5 kV	3	250 V	4 kV	2	600 V	
CX 8/24	8	—	16 A	230 / 400 V	4 kV	3	400 V	4 kV	2	600 V	Crimp
	—	24	10 A	160 V	2,5 kV	3	250 V	4 kV	2	600 V	

 All inserts with built-in contacts are provided with **silver plated contacts**, unless otherwise specified.

¹⁾ Please check the insert derating diagrams to establish the actual maximum operating current according to the ambient temperature.

MIXO POWER AND SIGNAL MODULAR INSERTS

SECTION C

Inserts series	No. of poles		Rated current ²⁾	EN 61984 (2009-06) pollution degree 3			EN 61984 (2009-06) pollution degree 2			UL / CSA certification	Conductor connection technology
	Contacts			Rated voltage	Rated impulse voltage	Pollution degree	Rated voltage	Rated impulse voltage	Pollution degree	Rated voltage AC or DC	
	Main ¹⁾	Aux.									
CX 01(B) 30	1	—	300 A	1000 V	8 kV	3	920 / 1600 V	8 kV	2	600 V	Crimp
CX 01(B) 30PE	PE contact	—	—	—	—	—	—	—	—	—	Crimp
CX 01 30A	1	—	300 A	1000 V	8 kV	3	—	—	—	600 V	90° screw
CX 01 30PEA	PE contact	—	—	—	—	—	—	—	—	—	90° screw
CX 01 Y	1	—	200 A	1000 V	8 kV	3	920 / 1600 V	8 kV	2	600 V	Crimp
CX 01 YPE	PE contact	—	—	—	—	—	—	—	—	—	Crimp
CX 01 YA	1	—	200 A	1000 V	8 kV	3	—	—	—	600 V	90° screw
CX 01 YPEA	PE contact	—	—	—	—	—	—	—	—	—	90° screw
CX 02 G	2	—	100 A	1000 V	8 kV	3	920 / 1600 V	8 kV	2	600 V	Crimp
CX 01 G	1	—	100 A	830 V	8 kV	3	—	—	—	600 V	Crimp
CX 01 GPE	PE contact	—	—	—	—	—	—	—	—	—	Crimp
CX 01 PE	PE contact	—	—	—	—	—	—	—	—	—	Screw
CX 02 7	2	—	70 A	1000 V	8 kV	3	1600 V	12 kV	2	600 V	Crimp
CX 02 4A	2	—	40 A	1000 V	8 kV	3	1600 V	12 kV	2	600 V	Screw
CX 02 4B	2	—	40 A	1000 V	8 kV	3	1600 V	12 kV	2	600 V	Screw
CX 02 4H	2	—	40 A	2500 / 5000 V	15 kV	3	—	—	—	5000 V	Crimp
CX 02 4	2	—	40 A	1000 V	8 kV	3	—	—	—	600 V	Crimp
CX 02 4Y	2	—	40 A	1000 V	8 kV	3	—	—	—	600 V	AXYR® Spring
CX 04 X	4	—	40 A	830 V	8 kV	3	1000 V	8 kV	2	600 V	Crimp
CX 04 XY	4	—	40 A	830 V	8 kV	3	—	—	—	600 V	AXYR® Spring
CX 3/4 XD	3	—	40 A	830 V	8 kV	3	—	—	—	600 V	Crimp
	—	4	10 A	830 V	8 kV	3	—	—	—	600 V	
CX 03 4B	3	—	40 A	500 V	6 kV	3	—	—	—	600 V	Crimp
CX 03 4	3	—	40 A	400 / 690 V	6 kV	3	—	—	—	600 V	Crimp
CX 03 4Y	3	—	40 A	400 / 690 V	6 kV	3	—	—	—	600 V	AXYR® Spring
CX 02 H	2	—	16 A	2900 / 5000 V	15 kV	3	—	—	—	5000 V	Crimp
CX 02 CH	2	—	16 A	2500 V	15 kV	3	—	—	—	2500 V	Crimp
CX 06P C	6	—	16 A	830 V	8 kV	3	—	—	—	600 V	Crimp
CX 20 C	20	—	16 A	500 V	6 kV	3	830 V	8 kV	2	600 V	Crimp
CX 06 C	6	—	16 A	500 V	6 kV	3	400 / 690 V	6 kV	2	600 V	Crimp
CX 06 CY	6	—	16 A	500 V	6 kV	3	—	—	—	600 V	AXYR® Spring
CX 08 C	8	—	16 A	400 V	6 kV	3	400 / 690 V	6 kV	2	600 V	Crimp
CX 08 CY	8	—	16 A	400 V	6 kV	3	—	—	—	600 V	AXYR® Spring
CX 05 SH	5	—	16 A	400 V	6 kV	3	500 V	6 kV	2	600 V	SQUICH® Spring
CX 12 D	12	—	10 A	250 V	4 kV	3	—	—	—	600 V	Crimp

MIXO POWER AND SIGNAL MODULAR INSERTS

SECTION C

Inserts series	No. of poles		Rated current ²⁾	EN 61984 (2009-06) pollution degree 3			EN 61984 (2009-06) pollution degree 2			UL / CSA certification	Conductor connection technology
	Contacts			Rated voltage	Rated impulse voltage	Pollution degree	Rated voltage	Rated impulse voltage	Pollution degree	Rated voltage AC or DC	
	Main ¹⁾	Aux.									
CX 12 DY	12	—	10 A	250 V	4 kV	3	—	—	—	600 V	AXYR® Spring
CX 17 D	17	—	10 A	160 V	2,5 kV	3	250 V	4 kV	2	600 V	Crimp
CX 42 D	42	—	10 A	150 V	2,5 kV	3	—	—	—	250 V	Crimp
CX 25 IB	25	—	4 A	50 V	0,8 kV	3	160 V	2,5 kV	2	600 V	Crimp
CX 36 I	36	—	4 A	32 V	0,8 kV	3	—	—	—	30 V	Crimp
CX FM	Dummy module										—

☑ All inserts with built-in contacts are provided with **silver plated contacts**, unless otherwise specified.

- 1) PE connection for MIXO modules is provided on each MIXO frame, except for MIXO-specific PE versions identified in the product table by "PE contact".
- 2) Please check the insert derating diagrams to establish the actual maximum operating current according to the ambient temperature.

MIXO SHIELDED AND BUS MODULAR INSERTS

SECTION C

Inserts series	No. of poles		Rated current ²⁾	EN 61984 (2009-06) pollution degree 3			EN 61984 (2009-06) pollution degree 2			UL / CSA certification	Conductor connection technology
	Contacts			Rated voltage	Rated impulse voltage	Pollution degree	Rated voltage	Rated impulse voltage	Pollution degree	Rated voltage AC or DC	
	Main ¹⁾	Aux.									
Shielded modular inserts											
CX 08 D5	8	—	10 A	50 V	0,8 kV	3	—	—	—	50 V	Crimp
CX 08 D5..2	8	—	10 A	50 V	0,8 kV	3	—	—	—	50 V	Crimp
CX 08 D5G	8	—	10 A	50 V	0,8 kV	3	—	—	—	50 V	Crimp
CX 08 D5G..2	8	—	10 A	50 V	0,8 kV	3	—	—	—	50 V	Crimp
CX 08 I6	8	—	5 A	50 V	0,8 kV	3	—	—	—	50 V	Crimp
CX 08 I6G	8	—	5 A	50 V	0,8 kV	3	—	—	—	50 V	Crimp
CX 20S I	20	—	4 A	32 V	0,8 kV	3	—	—	—	32 V	Crimp
CX 20S IG	20	—	4 A	32 V	0,8 kV	3	—	—	—	32 V	Crimp
Shielded bus											
CX 02 B	2	—	—	50 V	0,8 kV	3	—	—	—	50 V	—
CX 01 BC	1 (+ shield) (50 Ω coax)	—	16 A	50 V	0,8 kV	3	—	—	—	50 V	Crimp
CX 01 B	1 (+ shield) (75 Ω coax)	—	10 A	50 V	0,8 kV	3	—	—	—	50 V	Crimp
CX 04 B	4 (+ shield)	—	10 A	50 V	0,8 kV	3	—	—	—	50 V	Crimp
CX 08 B	8 (+ shield)	—	5 A	50 V	0,8 kV	3	—	—	—	50 V	Crimp

- 1) PE connection for MIXO modules is provided on each MIXO frame, except for MIXO-specific PE versions identified in the product table by "PE contact".
- 2) Please check the insert derating diagrams to establish the actual maximum operating current according to the ambient temperature.

MIXO DATA MODULAR INSERTS

SECTION C

Inserts series	No. of poles		Rated current ²⁾	EN 61984 (2009-06) pollution degree 3			EN 61984 (2009-06) pollution degree 2			UL / CSA certification	Conductor connection technology
	Main ¹⁾	Aux.		Rated voltage	Rated impulse voltage	Pollution degree	Rated voltage	Rated impulse voltage	Pollution degree	Rated voltage AC or DC	
CX 01 J8	1 RJ45 Cat.6 _A	—	1 A	50 V	0,8 kV	3	—	—	—	50 V	Crimp
CX 01 J8I	1 RJ45 Cat.6 _A	—	1 A	50 V	0,8 kV	3	—	—	—	50 V	IDC
CX 01 J8U	1 RJ45	—	1 A	for 1 RJ45 Cat. 6 _A Class E _A or 1 RJ45 Cat. 6 _A						Patch-cord	
CX 01 J	1 RJ45 Cat.5	—	—	—	—	—	—	—	—	50 V	Crimp
	—	4	10 A	250 V	4 kV	3	—	—	—	600 V	
CX 02 J	2 RJ45 Cat.5	—	—	—	—	—	—	—	—	50 V	Crimp
	—	8	10 A	250 V	4 kV	3	—	—	—	600 V	
CX 01 U	1 USB insert	—	1 A	50 V	0,8 kV	3	—	—	—	50 V	—
CX 01 MI	1 HDMI insert	—					—	—	—		—
CX 01 9V	9 (+ shield)	—	5 A	50 V	0,8 kV	3	—	—	—	50 V	Crimp
CX 01 9V2	9 (+ shield)	—	5 A	50 V	0,8 kV	3	—	—	—	50 V	Crimp
CX 01 9VT	2 (+ shield) for RS-485 bus T-connection	—	5 A	50 V	0,8 kV	3	—	—	—	50 V	Screw
CX 04 R	4	—	1,5 A	50 V	0,8 kV	3	crimp coaxial contacts DIN 41626-T2			50 V	Crimp
CX 04 L	4	—	contacts for POF or MOST® fibre optic contacts DIN 41626-3							Crimp	
CX 04 SC	4 (seats/poles)	—	contacts for glass fibre optic of 50 / 125 µm or 62,5 / 125 µm or for POF of Ø 1 mm							Crimp	
CX 06 LC	6 (seats/poles)	—	contacts for glass fibre optic of 9 / 125 µm or 50 / 125 µm or 62,5 / 125 µm							Crimp	

1) PE connection for MIXO modules is provided on each MIXO frame, except for MIXO-specific PE modules identified in the product table by "PE contact".

2) Please check the insert derating diagrams to establish the actual maximum operating current according to the ambient temperature.

MIXO PNEUMATIC MODULAR INSERTS

SECTION C

Inserts	No. of poles	Main features	Conductor connection technology
	Main contacts		
CX 03 P	3 plastic pneumatic contacts	for compress air up to 8 bar, for tube inner diameter (ID) Ø 1,6-3,0-4,0-6,0 mm	—
CX 02 P	2 plastic pneumatic contacts	for compress air up to 8 bar, for tube inner diameter (ID) Ø 6,0 mm	—
CX 03 MP	3 metal pneumatic contacts	for compress air up to 10 bar, for tube inner and outer diameter (ID/OD) Ø 3,0-4,0-6,0 mm	—
CX 02 MPB	2 metal pneumatic contacts	for compress air up to 10 bar, for tube inner and outer diameter (ID/OD) Ø 8,0-10 mm	—

PCB ADAPTERS FOR INSERTS

SECTION D

Inserts series	No. of poles		Rated current	EN 61984 (2009-06) pollution degree 3			EN 61984 (2009-06) pollution degree 2			UL / CSA certification	Conductor connection technology
	Main	Aux.		Rated voltage	Rated impulse voltage	Pollution degree	Rated voltage	Rated impulse voltage	Pollution degree	Rated voltage AC or DC	
PCB adapters for 21.21 size inserts											
CIF Q05 2.4	5	—	10 A	250 V	4 kV	3	—	—	—	250 V	—
CIF Q07 2.4	7	—	7,5 A	250 V	4 kV	3	—	—	—	250 V	—
CIF Q12 2.4	12	—	7,5 A	250 V	4 kV	3	—	—	—	250 V	—
PCB adapters for 32.13 size inserts											
CIF Q4/2 2.4	4	—	30 A	—	—	—	400 / 690 V	6 kV	2	600 V	—
	—	2	7,5 A	—	—	—	250 V	4 kV	2	250 V	
CIF Q08 1.6	8	—	16 A	—	—	—	230 / 400 V	4 kV	2	600 V	—
PCB adapters for standard size inserts and MIXO modular inserts											
CIF 2.4	6	—	7,5 A	160 V	4 kV	3	—	—	—	160 V	—
CIF 5 2.4	5	—	7,5 A	160 V	4 kV	3	—	—	—	160 V	—
CIF X17 2.4	17	—	7,5 A	160 V	4 kV	3	—	—	—	160 V	—

HNM INSERTS
SECTION H

Inserts series	No. of poles		Rated current ²⁾	EN 61984 (2009-06) pollution degree 3			EN 61984 (2009-06) pollution degree 2			UL / CSA certification	Conductor connection technology
	Contacts			Rated voltage	Rated impulse voltage	Pollution degree	Rated voltage	Rated impulse voltage	Pollution degree	Rated voltage AC or DC	
	Main + PE ¹⁾	Aux.									
21.21 size inserts											
CQ4 03	3	—	40 A	400 V	6 kV	3	—	—	—	600 V	Crimp
RQ 05	5	—	16 A	230 / 400 V	4 kV	3	320 / 500 V	4 kV	2	600 V	Crimp
CQ 21	21 (without PE)	—	6,5 A	50 V _{AC} / 120 V _{DC}	0,8 kV	3	—	—	—	250 V	Crimp
CD	8 (without PE)	—	10 A	50 V _{AC} / 120 V _{DC}	0,8 kV	3	—	—	—	50 V _{AC} / 120 V _{DC}	Crimp
Standard size inserts											
RCE	6, 10, 16, (32), 24, (48)	—	16 A	500 V	6 kV	3	400 / 690 V	6 kV	2	600 V	Crimp
RSH	6, 10, 16, (32), 24, (48)	—	16 A	500 V	6 kV	3	400 / 690 V	6 kV	2	600 V	SQUICH® Spring
RQEE	40, 64	—	16 A	500 V	6 kV	3	—	—	—	600 V	Crimp
RD	40, (80), 64, (128)	—	10 A	250 V	4 kV	3	230 / 400 V	4 kV	2	600 V	Crimp
RDD	24, 42, 72, (144), 108, (216)	—	10 A	—	—	—	250 V	4 kV	2	600 V	Crimp
RDSH	9, 18, 27, (54), 42, (84)	—	10 A	400 V	6 kV	3	400 / 690 V	6 kV	2	600 V	SQUICH® Spring
Combined inserts											
RXC 4/2	4	—	80 A	830 V	8 kV	3	—	—	—	600 V	Crimp
	—	2	16 A	400 V	6 kV	3	—	—	—	600 V	
RXC 4/8	4	—	80 A	400 V	6 kV	3	—	—	—	600 V	Crimp
	—	8	16 A	230 / 400 V	4 kV	3	—	—	—	600 V	
RX 12/2	12	—	40 A	690 V	8 kV	3	—	—	—	600 V	Crimp
	—	2	10 A	250 V	4 kV	3	—	—	—	600 V	
Power and signal MIXO modular inserts³⁾											
CX 02 7	2	—	70 A	1000 V	8 kV	3	1600 V	12 kV	2	600 V	Crimp
CX 02 4	2	—	40 A	1000 V	8 kV	3	—	—	—	600 V	Crimp
CX 04 X	4	—	40 A	830 V	8 kV	3	1000 V	8 kV	2	600 V	Crimp
CX 3/4 XD	3	—	40 A	830 V	8 kV	3	—	—	—	600 V	Crimp
	—	4	10 A	830 V	8 kV	3	—	—	—	600 V	
CX 03 4B	3	—	40 A	500 V	6 kV	3	—	—	—	600 V	Crimp
CX 03 4	3	—	40 A	400 / 690 V	6 kV	3	—	—	—	600 V	Crimp
CX 06P C	6	—	16 A	830 V	8 kV	3	—	—	—	600 V	Crimp
CX 20 C	20	—	16 A	500 V	6 kV	3	830 V	8 kV	2	600 V	Crimp
CX 06 C	6	—	16 A	500 V	6 kV	3	400 / 690 V	6 kV	2	600 V	Crimp
CX 08 C	8	—	16 A	400 V	6 kV	3	400 / 690 V	6 kV	2	600 V	Crimp
CX 12 D	12	—	10 A	250 V	4 kV	3	—	—	—	600 V	Crimp
CX 17 D	17	—	10 A	160 V	2,5 kV	3	250 V	4 kV	2	600 V	Crimp
CX 42 D	42	—	10 A	150 V	2,5 kV	3	—	—	—	250 V	Crimp
CX 25 IB	25	—	4 A	50 V	0,8 kV	3	160 V	2,5 kV	2	600 V	Crimp
CX 36 I	36	—	4 A	32 V	0,8 kV	3	—	—	—	30 V	Crimp

All HNM inserts with built-in contacts are provided with **HNM gold plated contacts**; those without built-in contacts shall be equipped with HNM gold plated contacts.

- Number of poles shown in brackets are achieved by using two inserts.
 - Please check the insert derating diagrams to establish the actual maximum operating current according to the ambient temperature.
 - PE connection for MIXO modules is provided on each MIXO frame, except for MIXO-specific PE modules identified in the product table by "PE contact".
- Contacts partially fitted inside an insert allow inserts to be used for applications requiring rated voltages higher than those shown. For **RD** and **RDD** inserts, refer to CD and CDD relevant tables inserts at page B.81.

HNM INSERTS

SECTION H

Inserts series	No. of poles		Rated current ²⁾	EN 61984 (2009-06) pollution degree 3			EN 61984 (2009-06) pollution degree 2			UL / CSA certification	Conductor connection technology
	Contacts			Rated voltage	Rated impulse voltage	Pollution degree	Rated voltage	Rated impulse voltage	Pollution degree	Rated voltage AC or DC	
	Main ¹⁾	Aux.									
MIXO Shielded modular inserts											
RX 08 D5	8	—	10 A	50 V	0,8 kV	3	—	—	—	50 V	Crimp
RX 08 D5..2	8	—	10 A	50 V	0,8 kV	3	—	—	—	50 V	Crimp
RX 08 D5G	8	—	10 A	50 V	0,8 kV	3	—	—	—	50 V	Crimp
RX 08 D5G..2	8	—	10 A	50 V	0,8 kV	3	—	—	—	50 V	Crimp
RX 08 I6	8	—	5 A	50 V	0,8 kV	3	—	—	—	50 V	Crimp
RX 08 I6G	8	—	5 A	50 V	0,8 kV	3	—	—	—	50 V	Crimp
RX 20 I	20	—	4 A	32 V	0,8 kV	3	—	—	—	32 V	Crimp
RX 20 IG	20	—	4 A	32 V	0,8 kV	3	—	—	—	32 V	Crimp
MIXO Pneumatic modular inserts											
CX 03 MP	3 metal pneumatic contacts		for compress air up to 10 bar, for inner or outer diameter tube (ID/OD) Ø 3,0-4,0-6,0 mm								—
CX 02 MPB	2 metal pneumatic contacts		for compress air up to 10 bar, for inner or outer diameter tube (ID/OD) Ø 8,0-10 mm								—

✎ All HNM inserts with built-in contacts are provided with **HNM gold plated contacts**; those without built-in contacts shall be equipped with HNM gold plated contacts.

- 1) PE connection for MIXO modules is provided on each MIXO frame, except for MIXO-specific PE modules identified in the product table by "PE contact".
- 2) Please check the insert derating diagrams to establish the actual maximum operating current according to the ambient temperature.

180 °C INSERTS

SECTION I

Inserts series	No. of poles		Rated current ²⁾	EN 61984 (2009-06) pollution degree 3			EN 61984 (2009-06) pollution degree 2			UL / CSA certification	Conductor connection technology
	Contacts			Rated voltage	Rated impulse voltage	Pollution degree	Rated voltage	Rated impulse voltage	Pollution degree	Rated voltage AC or DC	
	Main + PE ¹⁾	Aux.									
21.21 size inserts											
CK..RY	3, 4	—	10 A	230 / 400 V	4 kV	3	400 / 690 V	4 kV	2	600 V	Screw
Standard size inserts											
CNE..RY	6, 10, 16, (32), 24, (48)	—	16 A	500 V	6 kV	3	400 / 690 V	6 kV	2	600 V	Screw
CP..RY	6, (12)	—	35 A	400 / 690 V	6 kV	3	—	—	—	600 V	Screw
Combined inserts											
CX 4/0 RY	4	—	80 A	830 V	8 kV	3	—	—	—	600 V	Screw
CX 4/2 RY	4	—	80 A	830 V	8 kV	3	—	—	—	600 V	Screw
	—	2	16 A	400 V	6 kV	3	400 / 690 V	6 kV	2	600 V	
CX 4/8 RY	4	—	80 A	400 V	6 kV	3	400 / 690 V	6 kV	2	600 V	Screw
	—	8	16 A	230 / 400 V	4 kV	3	400 V	4 kV	2	600 V	

✎ All 180 °C inserts with built-in contacts are provided with **silver plated contacts**, unless otherwise specified.

- 1) Number of poles shown in brackets are achieved by using two inserts.
- 2) Please check the insert derating diagrams to establish the actual maximum operating current according to the ambient temperature.

ENCLOSURES SERIES

LOCKING SYSTEMS

The connection coupling's stability and protection against accidental openings is ensured by single or double locking devices comprising levers, springs and pegs – or screws or bayonets – in stainless steel, entirely in plastic, or in a combination of both.

ILME provides specific solutions for each application environment, giving the user the maximum choice in compatibility, reliability and performance.

C-TYPE Lever



The C-TYPE lever is a stainless steel lever with thermoplastic handles, designed to reduce the wear of the pegs on the hoods significantly, thanks to the presence of riveted rolls on a double spring mechanism.

Degree of protection
IP65 / IP66 / IP69

The C-TYPE locking system provides **smooth closure**, resilience and compensation for any coupling tolerance.

IL-BRID Lever



The IL-BRID mechanism, a lever made of thermoplastic with a stainless-steel core, combines the technical characteristics of both materials for a **durable** but significantly **low-wear design**.

Degree of protection
IP65 / IP66 / IP69

The IL-BRID locking lever is compatible with the entire range of ILME enclosures with pegs (in single or double-lever configuration) and offers an IP65 or IP66/ IP69 degree of protection, depending on the model.

V-TYPE Lever



The V-TYPE closing principle consists of a 2-step movement, thanks to the patented designed hinged elements pivoted on the housing: the lever is moved above the housing pegs and then pressed downwards to engage the locking mechanism.

Degree of protection
IP66 / IP67 / IP69

The **tight seal** after closure and the simplicity of the movement are the essential attributes that only ILME has managed to combine into a single lever.

JEI®-P Lever

Single-block locking lever in self-extinguishing thermoplastic material with **enhanced ergonomics and reduced dimension**, ideal for basic requirements and less demanding environments.

Degree of protection
IP65

T-TYPE Lever

The locking levers of T-TYPE series feature the same characteristics of the JEI®-P version: they have been designed in self-extinguishing thermoplastic material, grey RAL 7001 colour for standard and aggressive environment applications, **ergonomic and space-saving**.

Degree of protection
IP65 / IP66 / IP69

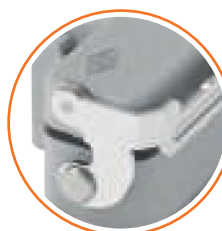


T-TYPE **HYGIENIC** lever, blue coloured, in **metal detectable thermoplastic material**, cleaning-oriented surface. For food and beverage applications.

Levers for Slim Enclosures**IL-BRID SLIM**

IL-BRID lever designed for slim enclosures.

IP65 / IP66 / IP69

**RIGID SLIM**

Stainless steel rigid lever for slim enclosures.

IP66 / IP67 / IP69

Levers for Compact Enclosures**21.21 C-TYPE**

Stainless steel resilient lever for 21.21 size enclosures.

- IP44
- IP66 / IP67 / IP69 with
CKR 65 kit

**21.21 THERMOPLASTIC**

Thermoplastic lever for 21.21 size enclosures.

Available in:
- White colour
- Black colour

**21.21 RIGID**

Rigid stainless or galvanized steel lever for 21.21 size enclosures.

- IP44
- IP66 / IP67 / IP69
with CKR 65 kit



- **HYGIENIC** lever in metal detectable thermoplastic material. For food and beverage applications.

IP65 / IP66 / IP69



ENCLOSURES SERIES

HOODS / HOUSINGS

ENCLOSURES

INTRO



ILME enclosures are available in many versions with different combinations of component materials, each suitable for specific environmental installation conditions from standard industrial heavy-duty applications to aggressive environments (outdoor or indoor) and specific sectors such as high temperature and electromagnetic compatibility.

Enclosures are made in die-cast aluminium (or zinc) alloy with a thermosetting powder coating or self-extinguishing insulating thermoplastic material.

They are designed to be resistant to impacts and mechanical solid stress.



ENCLOSURES SERIES - HOODS / HOUSINGS

SERIES

DESCRIPTION

Compact 21.21 size



The enclosure series 21.21 represents the ideal match for the same size compact and versatile connector inserts.

Industrial heavy-duty applications can benefit from a comprehensive product range in terms of installation possibilities (bulkhead-mounted, surface-mounted and cable-to-cable joints) and specific environment requirements.

Available for aggressive environment in W-TYPE and E-Xtreme® version.
Available for EMC, HYGIENIC, High temperature and HNM version.

Compact 32.13 size



The thermoplastic CQ/MQ series enclosures and the equivalent metal CQA/MQA versions offer a compact and easy-to-assemble solution for general use or specific applications.

Once completed and fitted with a suitably rated cable gland or conduit fitting, they ensure an IP66/IP67/IP69 degree of protection according to IEC/EN 60529 for outdoor or indoor environments.

Available for standard and EMC applications.

MIXO ONE and MIXO TWO

Special enclosures for modular inserts



MIXO ONE is the aluminium housing system designed by ILME to accept the wide range of MIXO series single-sized modules. These robust connector enclosures (3 hood variants and 1 bulkhead mounting housing) transform each single MIXO module into a completely independent connector.

MIXO TWO is the compact metal enclosure system designed by ILME to accept two of the wide range of MIXO series single-sized modules. These robust zinc die-cast connector enclosures are available as bulkhead, angled bulkhead mounting housings, and four hood variants, differing by the position and size of the cable entry: M25 or M32, horizontal or vertical.





Slim enclosures



Slim-size enclosures offer a practical compromise between compactness and connection density for industrial heavy-duty applications.

The product range is identified by its distinctive sizes: 49.16 and 66.16 for a single insert layout and 66.40 for a double insert layout. Slim-size enclosures have an IL-BRID locking device that combines the thermoplastic material's smoothness with the stainless steel's sturdiness. Slim size enclosures are also available with rigid stainless steel lever for IP67 degree of protection.

Available for aggressive environments in W-TYPE, E-Xtreme® or EMC versions.

MATERIALS	✔ CERTIFICATIONS	PAGE
<p>Compact 21.21 size</p> <ul style="list-style-type: none"> > Made of zinc die-cast alloy with epoxy-polyester coating or self-extinguishing thermoplastic material. > Lever in metal or self-extinguishing thermoplastic. > Gaskets in anti-aging, oil resistant, grease resistant and fuel resistant NBR elastomer or FKM elastomer (aggressive environment versions) or conductive elastomer (EMC versions). 	<p>IP44</p> <p>IP66 / IP67 / IP69 with CKR 65 kit</p> <p>IP68 (CGK / MGK series)</p> <p></p> <p>UL 50 / UL 50E (NEMA 250) Type 12 / 4 / 4X</p>	A.44
<p>Compact 32.13 size</p> <ul style="list-style-type: none"> > Made of zinc die-cast alloy, with zinc coating or self-extinguishing thermoplastic material. > Lever in metal or self-extinguishing thermoplastic. > Gaskets in anti-aging, oil resistant, grease resistant and fuel resistant NBR elastomer or conductive elastomer (EMC versions). 	<p>IP66 / IP67 / IP69</p> <p></p> <p>UL 50 / UL 50E (NEMA 250) Type 12 / 4 / 4X</p>	E.4
<p>MIXO ONE and MIXO TWO</p> <p>MIXO ONE</p> <ul style="list-style-type: none"> > Made of aluminium die-cast alloy. > Lever in stainless steel. > Gaskets in anti-aging, oil resistant, grease resistant and fuel resistant NBR elastomer. <p>MIXO TWO</p> <ul style="list-style-type: none"> > Made of zinc die-cast alloy with epoxy-polyester coating. > IL-BRID lever self-extinguishing thermoplastic material with stainless steel core. > Gaskets in anti-aging, oil resistant, grease resistant and fuel resistant NBR elastomer. 	<p>IP65</p> <p></p> <p>UL 50 / UL 50E (NEMA 250) Type 12 / 4 / 4X</p>	C.104
<p>Slim enclosures</p> <ul style="list-style-type: none"> > Made of aluminium die-cast alloy with epoxy-polyester coating (epoxy coating for aggressive environment versions). > IL-BRID lever self-extinguishing thermoplastic material with stainless steel core. Slim size enclosures are also available with rigid stainless steel lever for IP67 degree of protection. > Gaskets in anti-aging, oil resistant, grease resistant and fuel resistant NBR elastomer or FKM elastomer (aggressive environment versions) or conductive elastomer (EMC versions). 	<p>IP66 / IP67 / IP69</p> <p></p> <p>UL 50 / UL 50E (NEMA 250) Type 12 / 4 / 4X</p>	E.12

ENCLOSURES SERIES - HOODS / HOUSINGS

SERIES

DESCRIPTION

C-TYPE



The iconic C-TYPE Class series has been developed for use in electrical and electronic machinery, control units, electrical panels, control equipment, industrial environments, and anywhere else a reliable and easily disconnectable connection is required for power and signal circuits.

The C-TYPE locking system provides smooth closure, resilience, and compensation for any coupling tolerance.

IL-BRID



Specific industrial applications demand the design of equally customized connection solutions capable of covering each distinct installation requirement.

Among the enclosures' locking systems introduced by ILME in its product offer, the IL-BRID mechanism, a lever in thermoplastic material with a stainless-steel core, combines the technical characteristics of both these materials for durable but significantly low-wear design.

JEI®-P



The JEI®-P enclosure series features a fully thermoplastic locking lever, whose design is derived from the IL-BRID locking lever(s).

The series covers the standard enclosure sizes 44.27, 57.27, 77.27, and 104.27 with single and double levers, resulting in a versatile and ergonomic space-saving solution, allowing multiple installations side by side.

V-TYPE



The performance requirements in connection protection are increasingly varied and specialized. To respond to this wide range of needs, ILME has developed several original solutions, including the innovative V-TYPE lever.

This proprietary lever, due to the vertical closing movement, offers an IP66/IP67/IP69 degree of protection (according to EN 60529) when fitted with a complete and coupled connector and used with ILME standard hoods in die-cast aluminium moulded (without adapter).

MATERIALS	✓ CERTIFICATIONS	PAGE
<p>C-TYPE</p> <ul style="list-style-type: none"> > Made of aluminium die-cast alloy with epoxy-polyester powder coating. > C-TYPE locking device with self-extinguishing thermoplastic handles, springs and pins in stainless steel. > Gaskets in anti-aging, oil resistant, grease resistant and fuel resistant NBR elastomer. 	<p>IP65 / IP66 / IP69</p> <p></p> <p>UL 50 / UL 50E (NEMA 250)</p> <p>Type 12 / 4 / 4X</p>	E.46
<p>IL-BRID</p> <ul style="list-style-type: none"> > Made of aluminium die-cast alloy with epoxy-polyester powder coating. > IL-BRID locking device in self-extinguishing thermoplastic material and stainless steel core. > Gaskets in anti-aging, oil resistant, grease resistant and fuel resistant NBR elastomer. 	<p>IP65 / IP66 / IP69</p> <p></p> <p>UL 50 / UL 50E (NEMA 250)</p> <p>Type 12 / 4 / 4X</p>	E.88
<p>JEI®-P</p> <ul style="list-style-type: none"> > Made of aluminium die-cast alloy with epoxy-polyester powder coating. > JEI®-P locking device in self-extinguishing thermoplastic material. > Gaskets in anti-aging, oil resistant, grease resistant and fuel resistant NBR elastomer. 	<p>IP65</p> <p></p> <p>UL 50 / UL 50E (NEMA 250)</p> <p>Type 12 / 4 / 4X</p>	E.110
<p>V-TYPE</p> <ul style="list-style-type: none"> > Made of aluminium die-cast alloy with epoxy-polyester powder coating. > V-TYPE locking device in stainless steel. > Gaskets in anti-aging, oil resistant, grease resistant and fuel resistant NBR elastomer. 	<p>IP65 / IP66 / IP67 / IP69</p> <p></p> <p>UL 50 / UL 50E (NEMA 250)</p> <p>Type 12 / 4 / 4X</p>	E.122

ENCLOSURES SERIES - HOODS / HOUSINGS

SERIES

DESCRIPTION

IP68



For applications in the railway sector and whenever the following characteristics are demanded: high pressure, impact and corrosion resistance, with degree of protection IP68. They also guarantee a good shielding for electromagnetic compatibility.

W-TYPE



The W-TYPE enclosure series for aggressive environments is designed for industrial applications with particularly aggressive external agents.

The jet-black RAL 9005 colour identifies the series and, together with a pre-coating chromate conversion treatment RoHS 2 compliant, provides 50% improved corrosion resistance in salt spray tests (according to UNI EN ISO 9227).

E-Xtreme®



E-Xtreme® series hoods and housings are intended for highly demanding environments. The unique patented protective coating applied before the coating guarantees maximum protection against pollution, erosion and long-term exposure to corrosive agents.

Up to 3 000 hours in salt spray test (EN ISO 9227).

EMC



The ILME EMC series of connector enclosures and accessories has been designed for use in electrical/electronic equipment for machines.

Available as bulkhead mounting housings and hood versions in various sizes 44.27, 57.27, 77.27 and 104.27, they not only maintain the robustness and reliability of standard types but also offer increased high-frequency shielding characteristics, setting them apart from other options in the market.

MATERIALS	✓ CERTIFICATIONS	PAGE
<p>IP68</p> <ul style="list-style-type: none"> > Made of aluminium die-cast alloy with epoxy powder coating. > Locking device with either screws or bayonets (types with suffix B). > Gaskets in anti-aging, oil resistant, grease resistant and fuel resistant NBR elastomer. 	<p>IP66 / IP68 / IP69</p> <p></p> <p>UL 50 / UL 50E (NEMA 250)</p> <p>Type 12 / 4 / 4X</p>	E.138
<p>W-TYPE</p> <ul style="list-style-type: none"> > Made of aluminium die-cast alloy with epoxy powder coating. > V-TYPE or C-TYPE locking device with self-extinguishing thermoplastic handles, springs and pins in stainless steel. > FKM Fluoroelastomer gaskets (with improved resistance to chemicals and aging). 	<p>IP65 / IP66 / IP67 / IP69</p> <p></p> <p>UL 50 / UL 50E (NEMA 250)</p> <p>Type 12 / 4 / 4X</p>	E.152
<p>E-Xtreme®</p> <ul style="list-style-type: none"> > Made of aluminium die-cast alloy with special plasma coating and epoxy powder coating. > V-TYPE or C-TYPE locking device with self-extinguishing thermoplastic handles, springs and pins in stainless steel. > FKM Fluoroelastomer gaskets (with improved resistance to chemicals and aging). 	<p>IP65 / IP66 / IP67 / IP68 / IP69</p> <p></p> <p>UL 50 / UL 50E (NEMA 250)</p> <p>Type 12 / 4 / 4X</p>	E.172
<p>EMC</p> <ul style="list-style-type: none"> > Made of aluminium die-cast alloy. > IL-BRID locking device in self-extinguishing thermoplastic material and stainless steel core or C-TYPE stainless steel locking levers. > Conductive elastomer gaskets. 	<p>IP65 / IP66 / IP69</p> <p></p> <p>UL 50 / UL 50E (NEMA 250)</p> <p>Type 12 / 4</p>	E.200

ENCLOSURES SERIES - HOODS / HOUSINGS

SERIES

DESCRIPTION

T-TYPE and T-TYPE/W



Alongside the wide range of traditional metallic enclosures for multipole connectors, ILME first "pioneered" a series of enclosures in self-extinguishing thermoplastic material in the standard sizes 44.27, 57.27, 77.27, and 104.27.

The series design results in significant structural solidity and mechanical robustness, offering a technical, cost-effective solution for protecting connector inserts.

T-TYPE/H and T-TYPE/C



The HYGIENIC multi-pole connector enclosures version (series T-TYPE/H and T-TYPE/C) has been designed for installation on food industry machines and equipment.

Based upon the standard T-TYPE enclosure series, materials have been selected to comply with the requirements laid down by chapter 2.1 of Machinery Directive 2006/42/EC for accidental contact with food products and compatible with the cleaning and sanitising agents typically used in the food industry.

Based on the requirements outlined in EHEDG Guideline n. 32 "Materials of construction for food equipment in contact with food". Tested by Ecolab for compatibility with detergents and cleaning agents.

Central Lever







The series is specifically designed for industrial applications with limited installation space. Central Lever enclosures can be installed, placed side-by-side, and opened in a single operation.

BIG



BIG series introduces a significant change in the hood design and has been specifically developed to meet the wiring market's requirements in terms of conductor dimension and installation space.

The enclosures integrate the existing inserts range and are ideal for structured and complex wiring installations (e.g., power contacts with large wire cross-sections, pneumatic contacts and large wire bundles)

MATERIALS	✓ CERTIFICATIONS	PAGE
<p>T-TYPE and T-TYPE/W</p> <ul style="list-style-type: none"> > Structurally solid and mechanically robust, built using BC-MUL® moulding technique together with the use of MIL.BOX® UL 94V-2 material. > JEI®-P locking device in self-extinguishing thermoplastic material. > Built-in gaskets in polyurethane (standard) or FKM elastomer (-W). 	<p>IP65</p> <p></p> <p>UL 50 / UL 50E (NEMA 250)</p> <p>Type 12 (T-TYPE standard and T-TYPE /W)</p> <p>Type 4 / 4X Indoor Use Only (T-TYPE /W housings and T-TYPE standard hoods, only when combined with /W, /H and /C, counterpart)</p>	E.222
<p>T-TYPE/H and T-TYPE/C</p> <ul style="list-style-type: none"> > Structurally solid and mechanically robust, built using BC-MUL® moulding technique together with the use of MIL.BOX® UL 94V-2 material. > JEI®-P locking device in self-extinguishing thermoplastic material. > Built-in gaskets in HNBR rubber or SILICONE (-C) rubber formulated in accordance with FDA Guideline 21 CFR §177.2600. 	<p>IP66 / IP69</p> <p></p> <p>UL 50 / UL 50E (NEMA 250)</p> <p>Type 12</p> <p>Type 4 / 4X Indoor Use Only</p>	E.240
<p>Central Lever</p> <ul style="list-style-type: none"> > Made of aluminium die-cast alloy with epoxy-polyester powder coating. > Single lever compact stainless steel locking device. > Gaskets in anti-aging, oil resistant, grease resistant and fuel resistant NBR elastomer. 	<p>IP65</p> <p></p> <p>UL 50 / UL 50E (NEMA 250)</p> <p>Type 12 / 4 / 4X</p>	E.252
<p>BIG</p> <ul style="list-style-type: none"> > Made of aluminium die-cast alloy with epoxy-polyester powder coating. > V-TYPE locking device in stainless steel. > Gaskets in anti-aging, oil resistant, grease resistant and fuel resistant NBR elastomer. 	<p>IP65 / IP66 / IP67 / IP69</p> <p></p> <p>UL 50 / UL 50E (NEMA 250)</p> <p>Type 12 / 4 / 4X</p>	E.264

ENCLOSURES SERIES - HOODS / HOUSINGS

SERIES

DESCRIPTION

COB



The COB system of panel supports makes it possible to use multipole connectors within electric panels without the traditional metallic enclosures as protection is assured by the electric panel itself or others container.

The system may be assembled on panels with window snap fastening device; on DIN EN 60715 rails, both lengthways and crossways to the support; on fixed panels using screws.

LS-TYPE



The LS-TYPE enclosures are the ideal solution for the entertainment industry (lighting system power supply and related mixer and dimmer panels), including theatre stages, film sets, radio and TV studios, discos, trade fair booths, concert halls and night public events, indoors and outdoors.

All parts are in elegant RAL 9005 black, suitable for situations and locations where they should not be visible in the dark.

HNM



The HNM series of connector enclosures has been developed to be combined with the HNM series multipole connector inserts to provide the same reliable protection as the standard series but for a consistently extended, high number of matings.





When the number of 500 mating cycles guaranteed life of standard connector hoods and housings is insufficient to provide a reasonably long-life span in those connector applications that by function are foreseen to be subject to very frequent connections and disconnections, it is necessary to opt for a solution able to increase that guaranteed lifetime. The HNM series of connector enclosures achieves this goal, extending the guaranteed number of matings up to 10 000 (5 000 for the 21.21 size).

180 °C



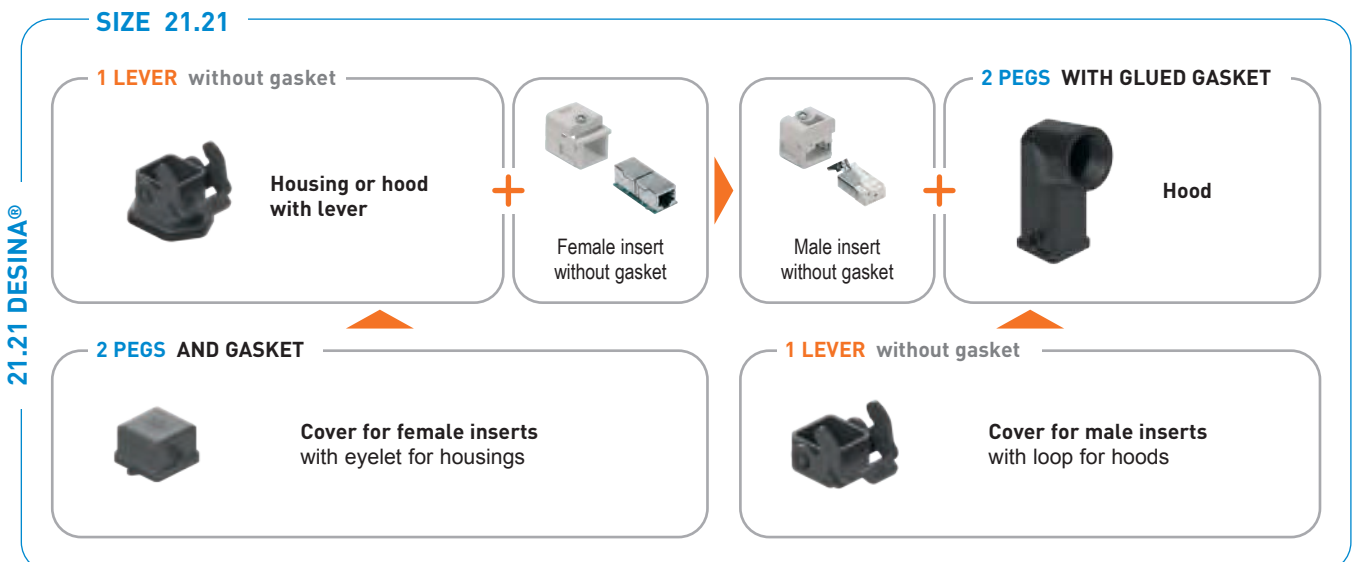
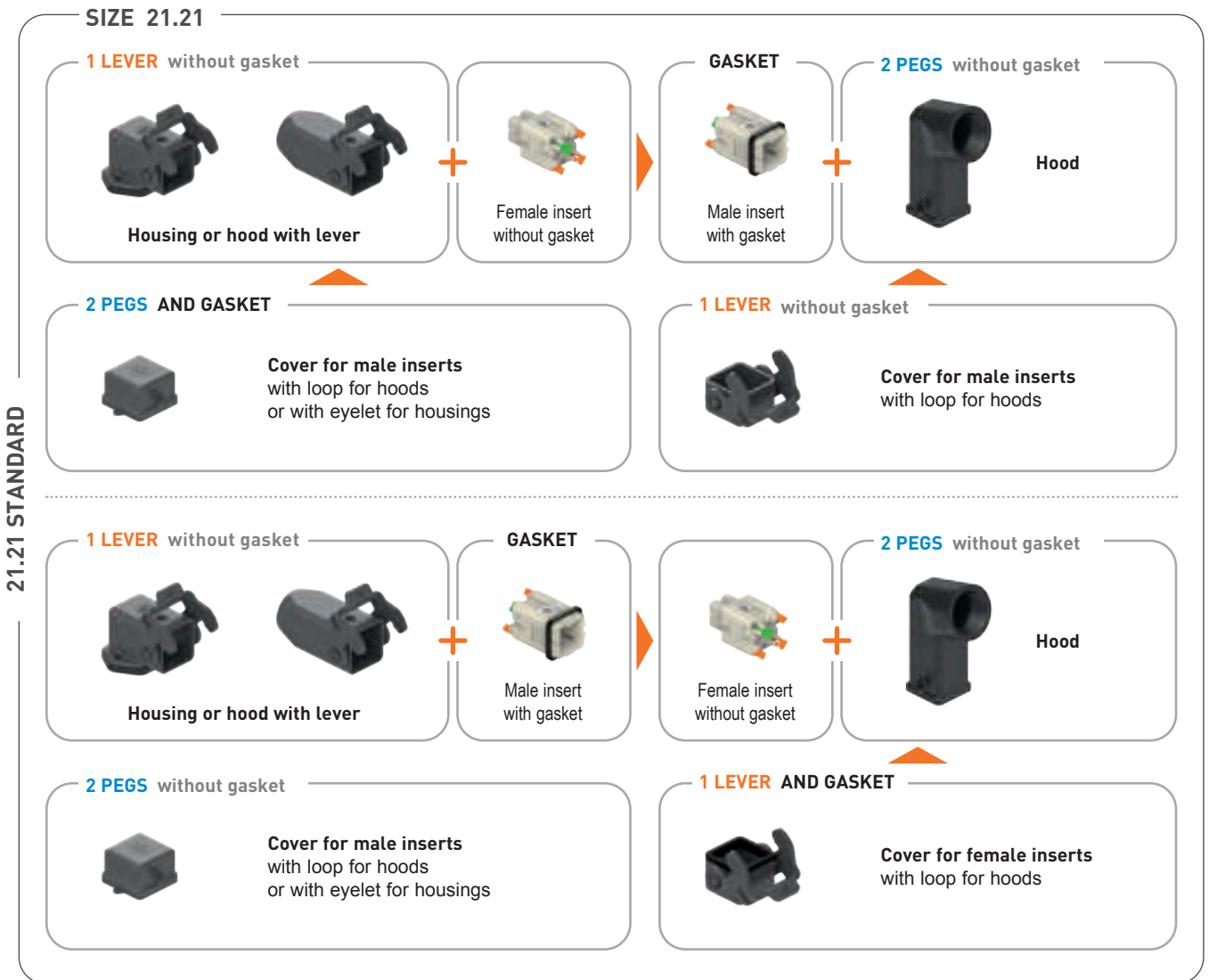
Series specifically developed for industrial applications where the temperatures can reach up to 180 °C. The aluminium die-cast unpainted enclosures are equipped with stainless steel levers and FKM red gaskets.

Available in the sizes 21.21, 44.27, 57.27, 77.27, 104.27, 77.62, and 104.62, to be used in combination with the ILME high-temperature connector inserts made by self-extinguishing thermoplastic material ("PPS" polyphenylene sulphide).

MATERIALS	✓ CERTIFICATIONS	PAGE
<p>COB</p> <ul style="list-style-type: none"> > Self-extinguishing thermoplastic insulating materials, UL certified (COB supports, locking levers, hoods), compatible with the -40 °C / +125 °C operating temperature range of connector inserts. 	<p>IP20</p> 	E.282
<p>LS-TYPE</p> <ul style="list-style-type: none"> > Made of aluminium die-cast alloy with epoxy-polyester powder coating. > JEI®-P locking device in self-extinguishing thermoplastic material. > Gaskets in anti-aging, oil resistant, grease resistant and fuel resistant NBR elastomer. 	<p>IP65</p>  <p>UL 50 / UL 50E (NEMA 250) Type 12 / 4 / 4X</p>	E.294
<p>HNM</p> <ul style="list-style-type: none"> > Made of aluminium die-cast alloy. > V-TYPE locking device in stainless steel. > Gaskets in anti-aging, oil resistant, grease resistant and fuel resistant NBR elastomer. 	<p>IP65</p>  <p>UL 50 / UL 50E (NEMA 250) Type 12 / 4 / 4X</p>	H.70
<p>180 °C</p> <ul style="list-style-type: none"> > Made of aluminium die-cast alloy with epoxy-polyester powder coating. > V-TYPE locking device in stainless steel. > Gaskets in FKM, anti-aging heat resistant fluoroelastomer. 	<p>IP65 / IP66 / IP67 / IP69</p>  <p>UL 50 / UL 50E (NEMA 250) Type 12 / 4</p>	I.14

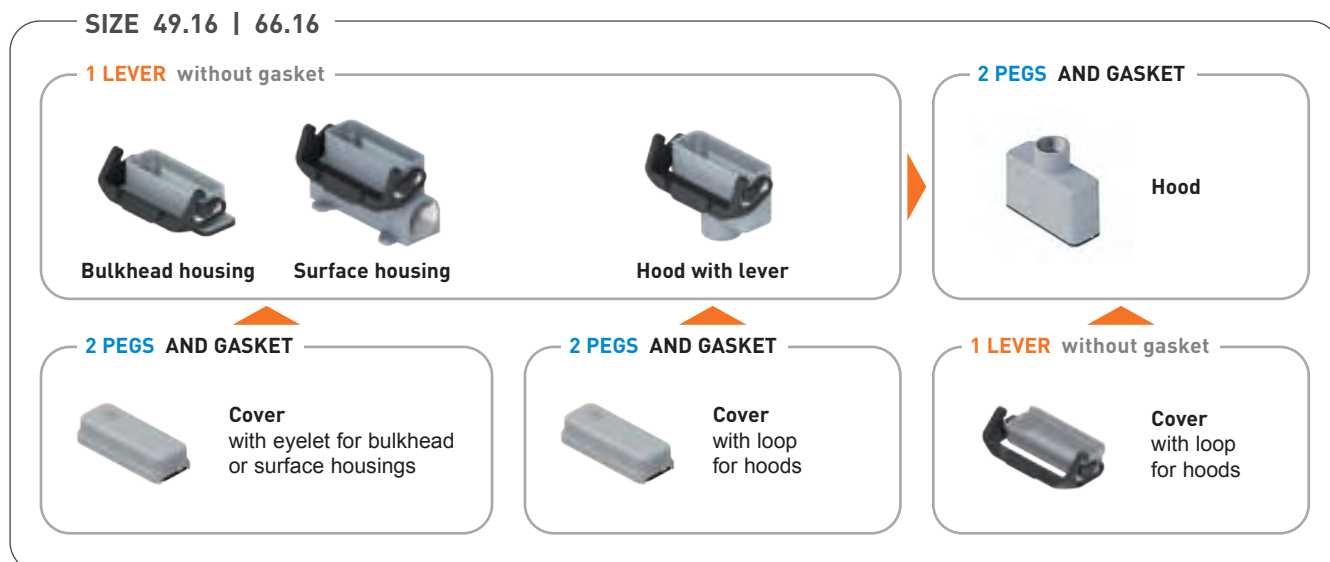
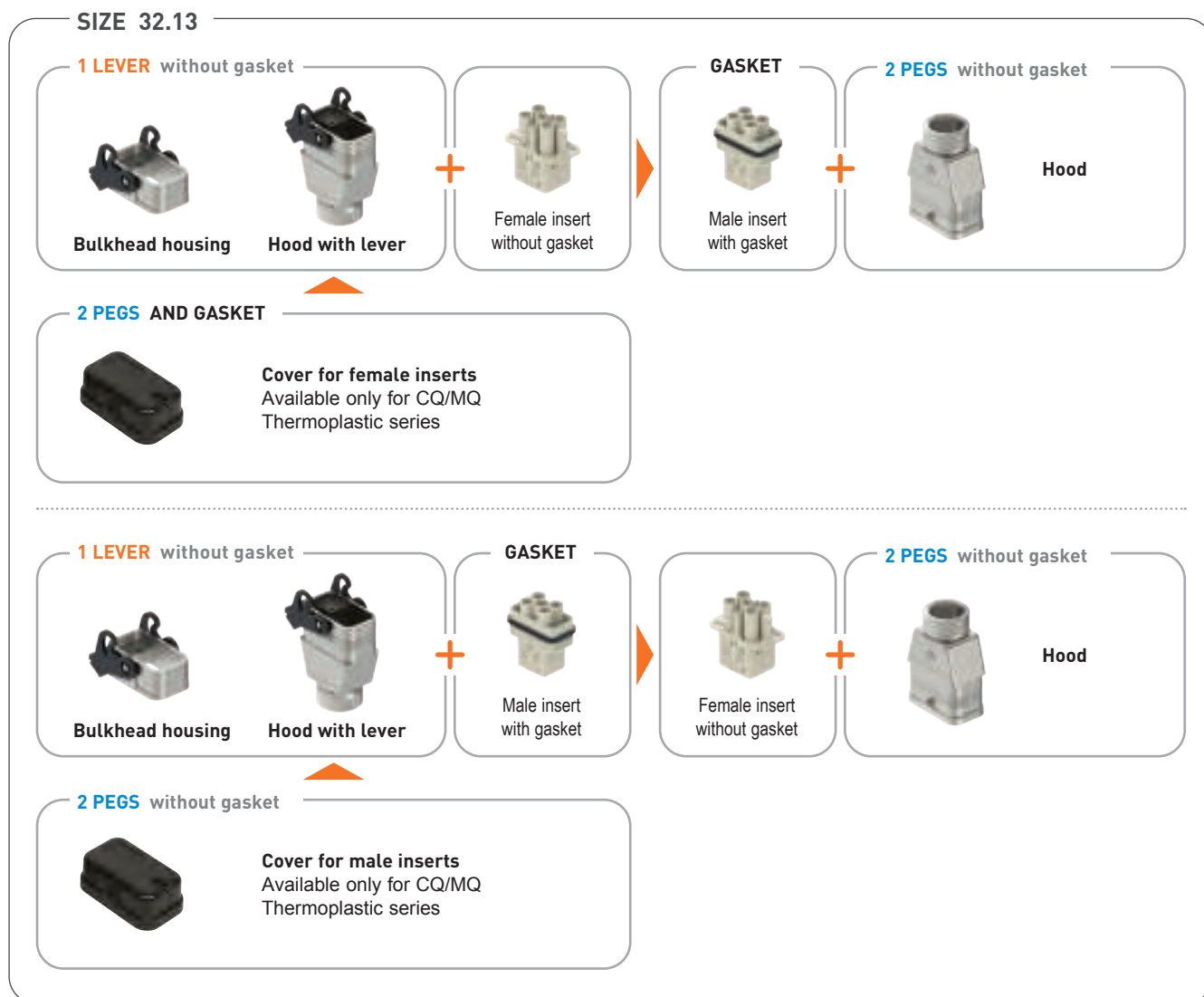
Housings, hoods, and covers selection guide

Coupling enclosures with **any type of locking lever** with the following sizes:



NOTE: All components in each coupling must be selected from the same size.

Coupling enclosures with **any type of locking lever** with the following sizes:



NOTE: All components in each coupling must be selected from the same size.



Housings, hoods, and covers selection guide

Coupling enclosures with **any type of locking lever** with the following sizes:

SIZE 44.27 | 57.27 | 77.27 | 104.27 | 77.62 | 104.62 | 66.40

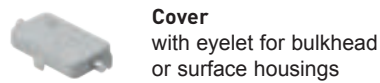
1 LEVER AND GASKET



2 PEGS without gasket



2 PEGS without gasket



2 PEGS without gasket



1 LEVER AND GASKET



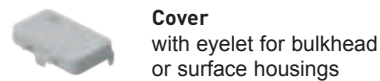
2 LEVERS AND GASKET



4 PEGS without gasket



4 PEGS without gasket



4 PEGS without gasket

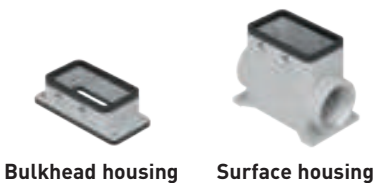


2 LEVERS AND GASKET



SIZE 44.27 | 57.27 | 77.27 | 104.27 | 77.62 | 104.62 | 66.40

4 PEGS AND GASKET



2 LEVERS without gasket



4 PEGS AND GASKET



2 PEGS AND GASKET



1 LEVER without gasket



2 PEGS AND GASKET



NOTE: All components in each coupling must be selected from the same size.



ENCLOSURES FEATURES

21.21 SIZE ENCLOSURES

SECTION A

Series	Size	Size ID	Version	Cable entry		IP (EN 60529)	UL 50 Type (NEMA 250 type)	Ambient temperature
Heavy-Duty Applications								
CK – MK	21.21	03	Thermoplastic	M20 M25	Pg 11	IP44 IP66 / IP67 / IP69*	12 4 / 4X*	-40 °C ... +125 °C
CKX – MKX	21.21	03	Thermoplastic with metal lever	M20 M25	Pg 11	IP44 IP66 / IP67 / IP69*	12 4 / 4X*	-40 °C ... +125 °C
CKA – MKA	21.21	03	Metallic	M20 M25	Pg 11	IP44 IP66 / IP67 / IP69*	12 4 / 4X*	-40 °C ... +125 °C
Aggressive Environments								
CKAW – MKAW	21.21	03	W-TYPE	M20 M25	Pg 11	IP44 IP66 / IP67 / IP69*	12 4 / 4X*	-40 °C ... +125 °C
CKAE – MKAE	21.21	03	E-Xtreme®	M20 M25	Pg 11	IP44 IP66 / IP67 / IP69*	12 4 / 4X*	-40 °C ... +125 °C
CKG – MKG	21.21	03	IP68 high protection	M20 M25	Pg 13,5	IP66 / IP68 / IP69	12 / 4 / 4X	-40 °C ... +125 °C
Specialized Applications								
CKAS – MKAS	21.21	03	EMC (Electromagnetic shielding)	M20 M25	Pg 11	IP44 IP66 / IP67 / IP69*	12 4 / 4X*	-40 °C ... +125 °C
CKH – MKH	21.21	03	HYGIENIC series for food and beverage	M20 M25	Pg 11	IP44 IP66 / IP67 / IP69*	12 4 / 4X*	-40 °C ... +70 °C

* With CKR 65 kit.

ENCLOSURES FOR MIXO MODULAR INSERTS

SECTION C

Series	Size	Size ID	Version	Cable entry		IP (EN 60529)	UL 50 Type (NEMA 250 type)	Ambient temperature
MIXO ONE CXA – MXA	for 1 module	01	Metallic	M25 M32	—	IP65	12 / 4 / 4X	-40 °C ... +125 °C
MIXO TWO CXA – MXA	for 2 modules	02	Metallic with IL-BRID lever(s)	M25 M32	—	IP65	12 / 4 / 4X (pending)	-40 °C ... +125 °C

32.13 SIZE ENCLOSURES

SECTION E

Series	Size	Size ID	Version	Cable entry		IP (EN 60529)	UL 50 Type (NEMA 250 type)	Ambient temperature
Heavy-Duty Applications								
CQ – MQ	32.13	08	Thermoplastic	M25	Pg 16 Pg 21	IP66 / IP67 / IP69	12 / 4 / 4X	-40 °C ... +125 °C
CQA – MQA*	32.13	08	Metallic	M25	—	IP66 / IP67 / IP69	12 / 4 / 4X	-40 °C ... +125 °C
Specialized Applications								
CQS – MQS*	32.13	08	Thermoplastic metallized EMC (Electromagnetic shielding)	—	Pg 16 Pg 21	IP66 / IP67	12	-40 °C ... +125 °C

* CR 08 EMC gasket available for improved electromagnetic shielding.

SLIM SIZE ENCLOSURES

SECTION E

Series	Size	Size ID	Version	Cable entry		IP (EN 60529)	UL 50 Type (NEMA 250 type)	Ambient temperature
Heavy-Duty Applications								
CZ – MZ	49.16 66.16	15 25	Metallic with IL-BRID lever(s)	M20 M25	Pg 13,5 Pg 16 Pg 21	IP65 / IP66 / IP69	12 / 4 / 4X	-40 °C ... +125 °C
JP – JM	49.16 66.16	15 25	Metallic with JEI®-P lever(s)	M20 M25	—	IP65	12 / 4 / 4X	-40 °C ... +125 °C
CH – MH	66.40	50	Metallic with C-TYPE lever(s)	M25 M32 M40	Pg 21 Pg 29	IP65 / IP66 / IP69	12 / 4 / 4X	-40 °C ... +125 °C
CHX – MHX	66.40	50	Metallic with rigid lever(s)	M32	Pg 21 Pg 29	IP66 / IP69	12 / 4 / 4X	-40 °C ... +125 °C
CZ7 – MZ7	49.16 66.16	15 25	IP67	M25	—	IP66 / IP67 / IP69	12 / 4 / 4X	-40 °C ... +125 °C
Aggressive Environments								
CZ7W – MZ7W	49.16 66.16	15 25	W-TYPE with rigid lever(s)	M20 M25	Pg 13,5 Pg 16 Pg 21	IP66 / IP67 / IP69	12 / 4 / 4X	-40 °C ... +125 °C
CHW – MHW	66.40	50	W-TYPE with C-TYPE lever(s)	M25 M32 M40	Pg 21 Pg 29	IP65 / IP66 / IP69	12 / 4 / 4X	-40 °C ... +125 °C
CHXW – MHXW	66.40	50	W-TYPE with rigid lever(s)	M32	Pg 21	IP66 / IP69	12 / 4 / 4X	-40 °C ... +125 °C
CZ7E – MZ7E	49.16 66.16	15 25	E-Xtreme® with rigid lever(s)	M20 M25	—	IP66 / IP67 / IP69	12 / 4 / 4X	-40 °C ... +125 °C
CHE – MHE	66.40	50	E-Xtreme® with C-TYPE lever(s)	M25 M32 M40	—	IP65 / IP66 / IP69	12 / 4 / 4X	-40 °C ... +125 °C
Specialized Applications								
CZ7S – MZ7S	49.16 66.16	15 25	EMC (Electromagnetic shielding) with rigid lever(s)	M20 M25	Pg 13,5 Pg 16 Pg 21	IP66 / IP67 / IP69	12 / 4 / 4X	-40 °C ... +125 °C

STANDARD SIZE ENCLOSURES

SECTION E

Series	Size	Size ID	Version	Cable entry		IP (EN 60529)	UL 50 Type (NEMA 250 type)	Ambient temperature
Heavy-Duty Applications								
CH – CA – CF MH – MA – MF	44.27	06	Standard metallic with C-TYPE lever(s)	M20	Pg 16 Pg 21 Pg 29 Pg 36 Pg 42	IP65 / IP66 / IP69	12 / 4 / 4X*	-40 °C ... +125 °C
	57.27	10		M25				
	77.27	16		M32				
	104.27	24		M40				
	77.62	32		M50				
104.62	48	M63						
CL – ML	44.27	06	Standard metallic with IL-BRID lever(s)	M20	—	IP65 / IP66 / IP69	12 / 4 / 4X	-40 °C ... +125 °C
	57.27	10		M25				
	77.27	16		M32				
	104.27	24		M40				
JPI – JMP – JPC	44.27	06	Standard metallic with JEI®-P lever(s)	M20	—	IP65	12 / 4 / 4X	-40 °C ... +125 °C
	57.27	10		M25				
	77.27	16		M32				
	104.27	24		M40				
C7I – M7P	44.27	06	IP67 with V-TYPE lever(s)	M20	Pg 16 Pg 21 Pg 29	IP65 / IP66 / IP67 / IP69	12 / 4 / 4X*	-40 °C ... +125 °C
	57.27	10		M25				
	77.27	16		M32				
	104.27	24		M40				
CV – MV	44.27	06	Standard metallic with V-TYPE lever(s)	M20	Pg 16 Pg 21 Pg 29	IP65 / IP66 / IP69	12 / 4 / 4X*	-40 °C ... +125 °C
	57.27	10		M25				
	77.27	16		M32				
	104.27	24		M40				
TCHI – TMA – TCHC	44.27	06	T-TYPE for standard applications	M25	—	IP65	12**	-40 °C ... +90 °C
	57.27	10		M32				
	77.27	16		M40				
	104.27	24						
THIW – TAPW TAVW – THCW	44.27	06	T-TYPE/W for aggressive environments	M25	—	IP66 / IP69	12 / 4 / 4X (Indoor Use Only)	-40 °C ... +90 °C
	57.27	10		M32				
	77.27	16		M40				
	104.27	24						
..YC – ..GYC – ..YX	44.27	06	Standard metallic with Central lever	M25	Pg 21 Pg 29 Pg 36	IP65	12 / 4 / 4X	-40 °C ... +125 °C
	57.27	10		M32				
	77.27	16		M40				
	104.27	24		M50				
CB – MB	44.27	06	BIG	M20	—	IP66 / IP69	12 / 4 / 4X	-40 °C ... +125 °C
	57.27	10		M25				
	77.27	16		M32				
	104.27	24		M40 M50				
Aggressive Environments								
C7IW – M7..W – MA..W – CA..W – MF..W	44.27	06	W-TYPE with V-TYPE lever(s)	M20	Pg 21 Pg 29	IP65 / IP66 / IP67 / IP69	12 / 4 / 4X	-40 °C ... +125 °C
	57.27	10		M25				
	77.27	16		M32				
	104.27	24		M40				

* ..LP versions with plastic cover have not the UL approval.

** 4/4X Indoor Use Only: hoods and covers without gasket or lever(s), when coupled with T-TYPE /W, T-TYPE /H or T-TYPE /C housings with gasket and/or lever(s).

STANDARD SIZE ENCLOSURES

SECTION E

Series	Size	Size ID	Version	Cable entry		IP (EN 60529)	UL 50 Type (NEMA 250 type)	Ambient temperature
CHIW – MA..W – CA..W	44.27	06	W-TYPE with C-TYPE lever(s)	M25 M32 M40 M50	Pg 21 Pg 29 Pg 36	IP65 / IP66 / IP69	12 / 4 / 4X	-40 °C ... +125 °C
	57.27	10						
	77.27	16						
	104.27	24						
	77.62	32						
104.62	48							
C7IE – M7PE MH..E – MF..E	44.27	06	E-Xtreme® with V-TYPE lever(s)	M20 M25 M32 M40	—	IP66 / IP67 / IP69	12 / 4 / 4X	-40 °C ... +125 °C
	57.27	10						
	77.27	16						
	104.27	24						
CH..E – MA..E	44.27	06	E-Xtreme® with C-TYPE lever(s)	M20 M25 M32 M40 M50	—	IP65 / IP66 / IP67 / IP69	12 / 4 / 4X	-40 °C ... +125 °C
	57.27	10						
	77.27	16						
	104.27	24						
	77.62	32						
104.62	48							
CG..E – MG..E	44.27	06	E-Xtreme® IP68 high protection version	M25 M32 M40 M50	—	IP66 / IP68 / IP69	12 / 4 / 4X	-40 °C ... +125 °C
	57.27	10						
	77.27	16						
	104.27	24						
CG – MG	44.27	06	IP68 high protection	M25 M32 M40 M50	Pg 21 Pg 29 Pg 36	IP66 / IP68 / IP69	12 / 4 / 4X	-40 °C ... +125 °C
	57.27	10						
	77.27	16						
	104.27	24						
Specialized Applications								
CLIS – ML..S – MH..S – CH..S – MF..S – CF..S	44.27	06	EMC (Electromagnetic shielding) with IL-BRID lever(s)	M25 M32 M40	Pg 21 Pg 29	IP65 / IP66 / IP69	12 / 4	-40 °C ... +125 °C
	57.27	10						
	77.27	16						
	104.27	24						
CHIS – MA..S – CA..S	44.27	06	EMC (Electromagnetic shielding) with C-TYPE lever(s)	M32	Pg 21	IP65 / IP66 / IP69	12 / 4	-40 °C ... +125 °C
	57.27	10						
	77.27	16						
	104.27	24						
THIH – TA..H THCH	44.27	06	HYGIENIC /H series or food and beverage	M25 M32 M40	—	IP66 / IP69	12 / 4 / 4X (Indoor Use Only)	-40 °C ... +70 °C
	57.27	10						
	77.27	16						
	104.27	24						
THIC – TA..C THCC	44.27	06	HYGIENIC /C series for food and beverage for low temperatures	M25 M32 M40	—	IP66 / IP69	12 / 4 / 4X (Indoor Use Only)	-50 °C ... +70 °C
	57.27	10						
	77.27	16						
	104.27	24						
COB	44.27	06	COB system for switch cabinet	—	—	IP20	—	-40 °C ... +125 °C
	57.27	10						
	77.27	16						
	104.27	24						
CH..N – MH..N – MF..N	44.27	06	LS-TYPE Light and Sound applications with JEI®-P lever(s)	M20 M25 M32	—	IP65	12 / 4 / 4X*	-40 °C ... +125 °C
	57.27	10						
	77.27	16						
	104.27	24						

* ..LP versions with plastic cover have not the UL approval.

HNM ENCLOSURES

SECTION H

Series	Size	Size ID	Version	Cable entry		IP (EN 60529)	UL 50 Type (NEMA 250 type)	Ambient temperature
Specialized Applications								
RKAX..	21.21	03	Metallic	M20 M25	Pg 11	IP44 IP66 / IP67 / IP69*	12 4 / 4X*	-40 °C ... +125 °C
RV – RH – RF	44.27 57.27 77.27 104.27	06 10 16 24	Standard metallic with V-TYPE lever(s)	M20 M25 M32 M40	—	IP65 / IP66 / IP69	12 / 4 / 4X	-40 °C ... +125 °C

* With CKR 65 kit.

180 °C ENCLOSURES

SECTION I

Series	Size	Size ID	Version	Cable entry		IP (EN 60529)	UL 50 Type (NEMA 250 type)	Ambient temperature
Specialized Applications								
CKAXR – MKAXR MKAR	21.21	03	Metallic	M20 M25	—	IP44	12 / 4 / 4X	-40 °C ... +180 °C
CV..R – MV..R MH..R – MF..R CH..R	44.27 57.27 77.27 104.27 77.62 104.62	06 10 16 24 32 48	Standard metallic with V-TYPE lever(s)	M20 M25 M32 M40	—	IP65	12 / 4 / 4X	-40 °C ... +180 °C



VISIT ILME.COM WEBSITE TO DISCOVER ALL THE MAIN FEATURES:

INTRO



Technical Datasheets

to get all the information about our products



Download Area

to find all the useful files in a click



Live Chat Tool

new integrated customer service platform to answer your questions faster



DISCOVER NEW FUNCTIONS AND PAGES TO WORK WITH US EVEN EASIER:



Configurator

Over 50 million connector combinations, in just a few clicks



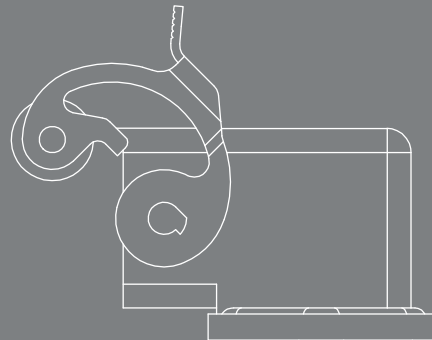
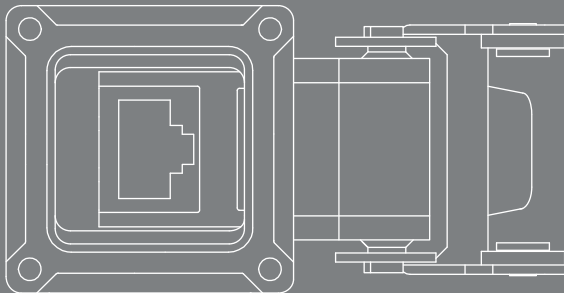
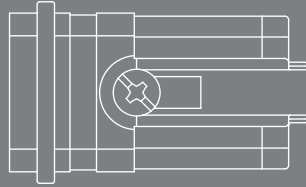
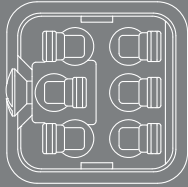
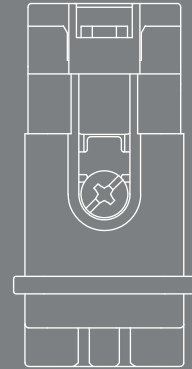
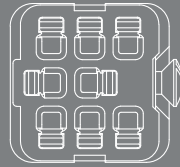
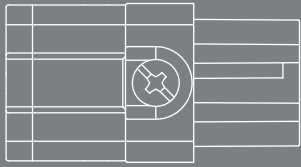
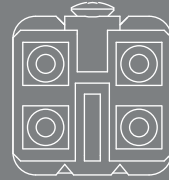
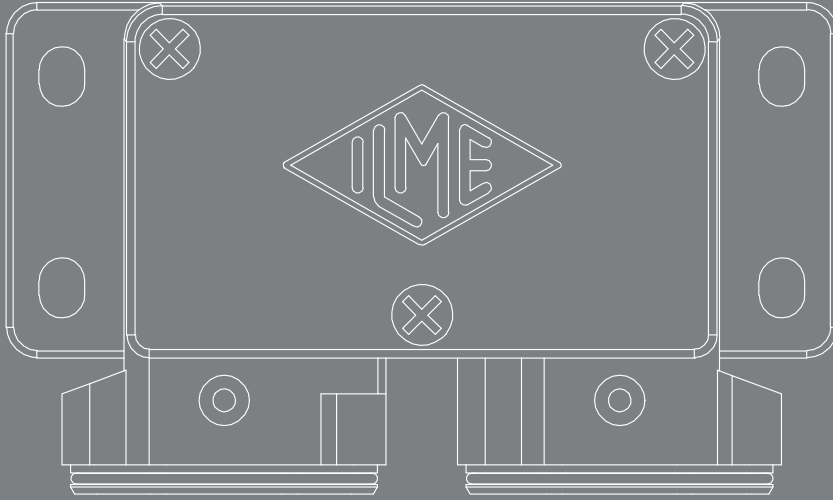
Application pages

Focus on installation locations, field requirements and technical details



Solutions

Focus on our key solutions, watching market needs and trends



GENERAL CATALOGUE

Compact 21.21 inserts and enclosures

Contents

21.21 inserts	CQ4 / CQ / CQY series	A.2
	<ul style="list-style-type: none"> - 40 A crimp A.4-7 - 16 A crimp / tool-less - AXYR® A.8-9 - 10 A crimp / tool-less - AXYR® A.10-11 - 6,5 A crimp A.12 	
	CK / CKSH series - 10 A screw / tool-less - SQUICH® A.16-19	A.14
	CD / CDY series - 10 A crimp / tool-less - AXYR® A.22-25	A.20
	Data RJ45 inserts selection guide A.28-29 - RJ45 Cat. 5 A.30 - RJ45 Cat. 6 _A A.31-35 - USB connectors A.36 - Shielded connectors A.37 - Fibre optic A.38	A.26
	Complete connectors - RJ45 Cat. 5 A.40-42 - ATR service interface A.43	
21.21 enclosures	Heavy-Duty Applications A.44 - Thermoplastic A.46-52 - Thermoplastic with metal lever A.53-55 - Metallic - CKA / MKA A.56-66	
	Aggressive Environments A.70 - W-TYPE A.72-75 - E-Xtreme® A.76-77 - IP68 high protection A.78-81	
	Specialized Applications A.82,92 - EMC (Electromagnetic Shielding) A.84-89 - HYGIENIC series for food and beverage A.94-96	

CQ4 and CQ connector series



CQ4F /M 03/2 original proprietary design for high density combination of 3P + ⊕ power and 2P brakes contacts

The **CQ4** and **CQ series** offer a versatile range of connectors in a compact size for broad use in numerous industrial heavy-duty applications, from high-current 40 A power wiring to 6,5 A signal connections.

The inserts are ideally complemented by a complete range of hoods and housings size 21.21, either insulating or metallic, available with Pg 11, M20 and M25 cable entry for use with high cross-sectional area conductors and large cable bundles.

KEY FEATURES

- > **Optional coding pins are available for CQ4 and CQ inserts series** (except for CQF /M 21) to prevent unwanted mating of two identical connectors. **Up to 16 different coding** arrangements for each specific insert/pin combination.
- > **PCB interface adapter for CQ 05, CQ 07 and CQ 12** suitable for printed circuit board application by soldering to PCBs with thickness up to 2,4 mm (see page D.4).
- > **High-density tool-less AXYR® CQY 05 insert with PE connection** compatible with the corresponding crimp versions) for prepared and unprepared conductor up to 4 mm² wire cross section.
- > **Optional bridge terminals (CR BDR, CR BST) for delta or star connection (for CQ 12)** for wires with cross-section ranging from 1,5 mm² to 2,5 mm² (16-14 AWG). See pages G.16-17.

CQ4 series overview

The inserts are designed to avoid direct contact when unmated (finger-proof IP2X), with a unique **polarisation key** on the connector's mating face to prevent the mismatching of low- and high-voltage versions.

Compatible with 40 A "CX" series crimp contacts (including the PE pre-leading one), stranded copper conductors' cross-sectional area from 1,5 mm² to 10 mm² (16 AWG to 8 AWG).

- > **CQ4F /M 02** with 2P + ⊕ – 400 V rated voltage, up to 40 A current-carrying capacity;
- > **CQ4F /M 02 H** with 2P + ⊕ – 40 A current-carrying capacity for high-voltage applications, up to 830 V;
- > **CQ4F /M 03** with 3P + ⊕ – 400 V rated voltage, up to 40 A current-carrying capacity;
- > **CQ4F /M 03/2** with 3P + ⊕ (+ 2P aux) – 40 A current-carrying capacity, 400 V rated voltage. Auxiliary contacts provide 10 A current-carrying capacity and 250 V rated voltage.

CQ series overview

The inserts inside this product range include 16 A, 10 A and 6,5 A connection solutions for up to 400 V rated voltage applications.

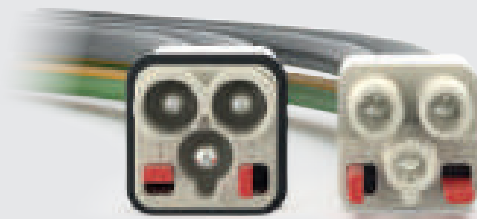
Suitable for standard crimp "CC", "CD", "CI" and stamped crimp SI contact series, the range is enhanced with the **AXYR**[®] tool-less connection technology (CQY 05 insert), giving wide conductor wire cross-section compatibility (from 0,14 mm² to 4 mm²).

- > **CQF /M 05** (crimp) and **CQYF /M 05** (tool-less **AXYR**[®]) with 5P + ⊕ – 16 A current-carrying capacity and rated voltage up to 400 V;
- > **CQF /M 07** with 7P + ⊕ – 16 A current-carrying capacity and high voltage applications, up to 830 V;
- > **CQF /M 12** with 12P + ⊕ – 10 A current-carrying capacity and rated voltage up to 400 V;
- > **CQF /M 21** with 21P – 6,5 A with 50 V rated voltage, SELV applications (Safety Extra Low Voltage).

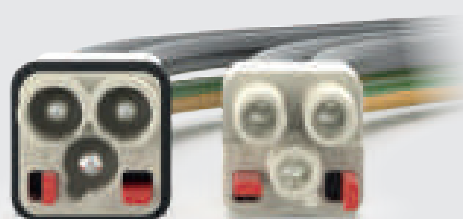
FOCUS

Polarisation key

The inserts are designed to avoid direct contact when unmated (finger-proof IP2X), with a unique **polarisation key** on the connector's mating face to prevent the mismatching of low- and high-voltage versions.



- > **CQ4F /M 02**
Lower voltage version



- > **CQ4F /M 02 H**
830 V Higher voltage version

CQ4 02 H

40 A 830 V

size **21.21**

2 poles +

Crimp connection

EN 61984 rating	40 A 830 V 6 kV 3
Rated voltage (UL / CSA)	600 V
Insulation resistance	≥ 10 GΩ
Contact resistance	≤ 0,3 mΩ
Ambient temperature limit	-40 °C ... +125 °C
Mechanical life (cycles)	≥ 500



ECBT2.E115072 | ECBT8.E115072
PVVA2.E506437 | PVVA8.E506437

Item	Description	Part No.	Dimension
	Male inserts for male contacts With heat-shrinking tube Without contacts, including PE (to be ordered separately) Male insert is protected from access with the back of the hand (IP1X or IPXXA)	CQ4M 02 H	
	Female inserts for female contacts With heat-shrinking tube Without contacts, including PE (to be ordered separately) Female insert is finger proof (IP2X or IPXXB) even if not coupled	CQ4F 02 H	

40 A crimp contacts	section (mm ²)		section (AWG)		Male	Female
		1,5	2,5	16	14	CXMA 1.5
	4	6	12	10	CXMA 4.0	CXFA 4.0
	10		8		CXMA 10	CXFA 10

silver

Wiring information, CX contacts

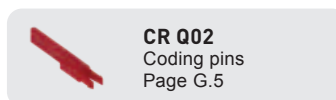
conductor section (mm ²)	conductor slot ø A (mm)	stripping length B (mm)
1,5	1,8	9
2,5	2,2	9
4	2,85	9,6
6	3,5	9,6
10	4,3	15

Wire diameter: up to 7 mm.

It is recommended to use the crimping tools and removal tools homologated by ILME (please see page F.23)

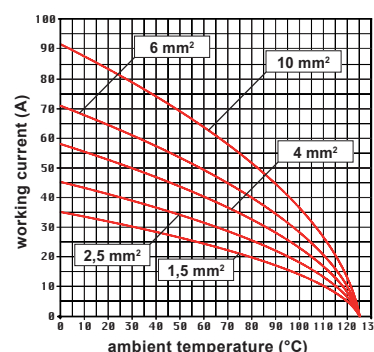
Materials

Insert	polycarbonate (PC)
UL 94 flame rating	V-0
Colour	pebble grey, RAL 7032
Contacts	copper alloy, silver ● plated



Compact 21.21 enclosures	Pages
Heavy-Duty Applications	
Thermoplastic	A.46-50
Thermoplastic with metal lever	A.53-55
Metallic	A.56-64
Aggressive Environments	
Metallic W-TYPE	A.72-75
Metallic E-Xtreme®	A.76-77
Metallic IP68 high protection	A.78-81
Specialized Applications	
EMC (Electromagnetic Shielding)	A.84-89
Hygienic series for food and beverage	A.94-96

Cannot be used in angled enclosures (IA / IAP versions and VA M20, Pg 11 entry version)



CQ4 02 H inserts max. current load derating diagram

CQ4 02

40 A 400 V

size **21.21**

2 poles +

Crimp connection

EN 61984 rating	40 A 400 V 6 kV 3
Rated voltage (UL / CSA)	600 V
Insulation resistance	≥ 10 GΩ
Contact resistance	≤ 0,3 mΩ
Ambient temperature limit	-40 °C ... +125 °C
Mechanical life (cycles)	≥ 500

CE UK EAC



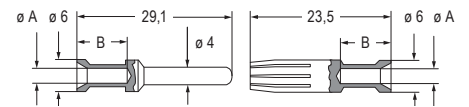
ECBT2.E115072 | ECBT8.E115072
PVVA2.E506437 | PVVA8.E506437

Item	Description	Part No.	Dimension
	Male inserts for male contacts Without contacts, including PE (to be ordered separately) Male insert is protected from access with the back of the hand (IP1X or IPXXA)	CQ4M 02	

	Female inserts for female contacts Without contacts, including PE (to be ordered separately) Female insert is finger proof (IP2X or IPXXB) even if not coupled	CQ4F 02	
--	--	-------------------------	--

40 A crimp contacts	section (mm ²)		section (AWG)		Male	Female
		1,5	2,5	16	14	CXMA 1.5
	4	6	12	10	CXMA 4.0	CXFA 4.0
	10		8		CXMA 10	CXFA 10

silver



Wiring information, CX contacts

conductor section (mm ²)	conductor slot ø A (mm)	stripping length B (mm)
1,5	1,8	9
2,5	2,2	9
4	2,85	9,6
6	3,5	9,6
10	4,3	15

Wire diameter: up to 7 mm.

It is recommended to use the crimping tools and removal tools homologated by ILME (please see page F.23)

Materials

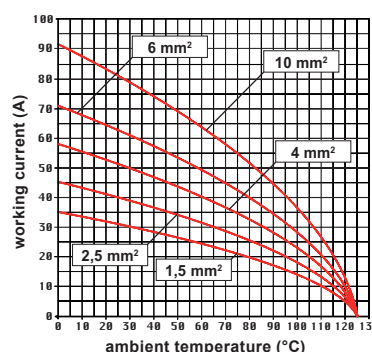
Insert	polycarbonate (PC)
UL 94 flame rating	V-0
Colour	pebble grey, RAL 7032
Contacts	copper alloy, silver plated



CR Q02
Coding pins
Page G.5

Compact 21.21 enclosures	Pages
Heavy-Duty Applications	
Thermoplastic	A.46-50
Thermoplastic with metal lever	A.53-55
Metallic	A.56-64
Aggressive Environments	
Metallic W-TYPE	A.72-75
Metallic E-Xtreme®	A.76-77
Metallic IP68 high protection	A.78-81
Specialized Applications	
EMC (Electromagnetic Shielding)	A.84-89
Hygienic series for food and beverage	A.94-96

Cannot be used in angled enclosures (IA / IAP versions and VA M20, Pg 11 entry version)



CQ4 02 inserts max. current load derating diagram

CQ4 03

40 A 400 V


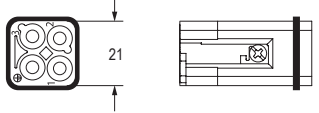

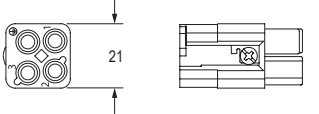
size **21.21**
3 poles + ⊕

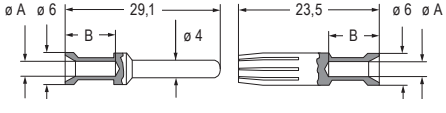
Crimp connection

EN 61984 rating	40 A 400 V 6 kV 3
Rated voltage (UL / CSA)	600 V
Insulation resistance	≥ 10 GΩ
Contact resistance	≤ 0,3 mΩ
Ambient temperature limit	-40 °C ... +125 °C
Mechanical life (cycles)	≥ 500



ECBT2.E115072 | ECBT8.E115072
PVVA2.E506437 | PVVA8.E506437

Item	Description	Part No.	Dimension
	Male inserts for male contacts Without contacts (to be ordered separately) Male insert is protected from access with the back of the hand (IP1X or IPXXA)	CQ4M 03	
	Female inserts for female contacts Without contacts (to be ordered separately) Female insert is finger proof (IP2X or IPXXB) even if not coupled	CQ4F 03	

40 A crimp contacts		Male	Female	
section (mm ²)	section (AWG)			
1,5	16	CXMA 1.5	CXFA 1.5	
2,5	14	CXMA 2.5	CXFA 2.5	
4	12	CXMA 4.0	CXFA 4.0	
6	10	CXMA 6.0	CXFA 6.0	
10	8	CXMA 10	CXFA 10	

Wiring information, CX contacts


conductor section (mm ²)	conductor slot ø A (mm)	stripping length B (mm)
1,5	1,8	9
2,5	2,2	9
4	2,85	9,6
6	3,5	9,6
10	4,3	15

Wire diameter: up to 7 mm.

It is recommended to use the crimping tools and removal tools homologated by ILME (please see page F.23)

Materials

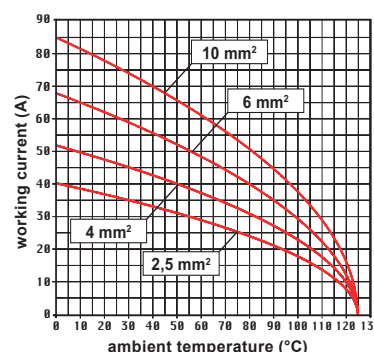
Insert	polycarbonate (PC)
UL 94 flame rating	V-0
Colour	pebble grey, RAL 7032
Contacts	copper alloy, silver ● plated



CR Q03
Coding pins
Page G.6

Compact 21.21 enclosures	Pages
Heavy-Duty Applications	
Thermoplastic	A.46-50
Thermoplastic with metal lever	A.53-55
Metallic	A.56-64
Aggressive Environments	
Metallic W-TYPE	A.72-75
Metallic E-Xtreme®	A.76-77
Metallic IP68 high protection	A.78-81
Specialized Applications	
EMC (Electromagnetic Shielding)	A.84-89
Hygienic series for food and beverage	A.94-96

Cannot be used in angled enclosures (IA / IAP versions and VA M20, Pg 11 entry version)



CQ4 03 inserts max. current load derating diagram



CQ4 03/2

40 A 400 V / 10 A 250 V

size **21.21**
3 / 2 poles + ⊕

Crimp connection

EN 61984 rating	40 A 400 V 6 kV 3	10 A 250 V 4 kV 3
Rated voltage (UL / CSA)	600 V	
Insulation resistance	≥ 10 GΩ	
Contact resistance	40 A (3 poles)	≤ 0,3 mΩ
	10 A (2 poles)	≤ 3 mΩ
Ambient temperature limit	-40 °C ... +100 °C	
Mechanical life (cycles)	≥ 500	



ECBT2.E115072 | ECBT8.E115072
PVVA2.E506437 | PVVA8.E506437

Item	Description	Part No.	Dimension
	Male inserts for male contacts Without contacts, including PE (to be ordered separately) Male insert is protected from access with the back of the hand (IP1X or IPXXA)	CQ4M 03/2	

	Female inserts for female contacts Without contacts, including PE (to be ordered separately) Female insert is finger proof (IP2X or IPXXB) even if not coupled	CQ4F 03/2	
--	---	---------------------------	--

	40 A crimp contacts	10 A crimp contacts	Male	Female		
	section (mm ²) section (AWG) 1,5 16 2,5 14 4 12 6 10	section (mm ²) section (AWG) 0,14-0,37 26-22 0,5 20 0,75 18 1 18 1,5 16 2,5 14	silver	CXMA 1.5 CXMA 2.5 CXMA 4.0 CXMA 6.0	CXFA 1.5 CXFA 2.5 CXFA 4.0 CXFA 6.0	
			silver	CDMA 0.3 CDMA 0.5 CDMA 0.7 CDMA 1.0 CDMA 1.5 CDMA 2.5	CDFA 0.3 CDFA 0.5 CDFA 0.7 CDFA 1.0 CDFA 1.5 CDFA 2.5	

Wiring information, CX and CD contacts

conductor section (mm ²)	conductor slot ø A (mm)	stripping length B (mm)	conductor section (mm ²)	conductor slot ø C (mm)	stripping length D (mm)
1,5	1,8	9	0,14-0,37	0,9	8
2,5	2,2	9	0,5	1,1	8
4	2,85	9,6	0,75	1,3	8
6	3,5	9,6	1,0	1,45	8
-	-	-	1,5	1,8	8
-	-	-	2,5	2,2	6

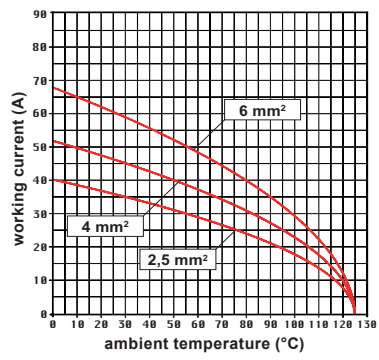
Wire diameter: up to 5,3 mm (CX series); up to 3,8 mm (CD series).
It is recommended to use the crimping tools and removal tools homologated by ILME (please see page F.23)

Materials	
Insert	polycarbonate (PC)
UL 94 flame rating	V-0
Colour	pebble grey, RAL 7032
Contacts	copper alloy, silver ● plated

CR Q03/2
Coding pins
Page G.7

Compact 21.21 enclosures	Pages
Heavy-Duty Applications	
Thermoplastic	A.46-50
Thermoplastic with metal lever	A.53-55
Metallic	A.56-64
Aggressive Environments	
Metallic W-TYPE	A.72-75
Metallic E-Xtreme®	A.76-77
Metallic IP68 high protection	A.78-81
Specialized Applications	
EMC (Electromagnetic Shielding)	A.84-89
Hygienic series for food and beverage	A.94-96

Cannot be used in angled enclosures (IA / IAP versions and VA M20, Pg 11 entry version)



CQ4 03/2 inserts max. current load derating diagram

CQ 05

16 A 230/400 V

 size **21.21**
5 poles + ⊕

Crimp connection

EN 61984 rating	16 A 230 / 400 V 4 kV 3
	16 A 320 / 500 V 4 kV 2
Rated voltage (UL / CSA)	600 V
Insulation resistance	≥ 10 GΩ
Contact resistance	≤ 1 mΩ
Ambient temperature limit	-40 °C ... +125 °C
Mechanical life (cycles)	≥ 500


 ECBT2.E115072 | ECBT8.E115072
 PVVA2.E506437 | PVVA8.E506437

Item	Description	Part No.	Dimension
	Male inserts for male contacts Without contacts, including PE (to be ordered separately) PE screw connection for unprepared wires only	CQM 05	

	Female inserts for female contacts Without contacts, including PE (to be ordered separately) PE screw connection for unprepared wires only	CQF 05	
--	---	------------------------	--

	16 A advanced opening contacts	Male	Female	
	section (mm ²) section (AWG) 0,5 20 0,75 18 1 18 1,5 16 2,5 14	CC 0.5 AN CC 0.7 AN CC 1.0 AN CC 1.5 AN CC 2.5 AN		
	16 A crimp contacts section (mm ²) section (AWG) 0,14-0,37 26-22 0,5 20 0,75 18 1 18 1,5 16 2,5 14 3 12 4 12	CCMA 0.3 CCMA 0.5 CCMA 0.7 CCMA 1.0 CCMA 1.5 CCMA 2.5 CCMA 3.0 CCMA 4.0	CCFA 0.3 CCFA 0.5 CCFA 0.7 CCFA 1.0 CCFA 1.5 CCFA 2.5 CCFA 3.0 CCFA 4.0	
	0,14-0,37 26-22 0,5 20 0,75 18 1 18 1,5 16 2,5 14 3 12 4 12	CCMD 0.3 CCMD 0.5 CCMD 0.7 CCMD 1.0 CCMD 1.5 CCMD 2.5 CCMD 3.0 CCMD 4.0	CCFD 0.3 CCFD 0.5 CCFD 0.7 CCFD 1.0 CCFD 1.5 CCFD 2.5 CCFD 3.0 CCFD 4.0	

Wiring information, CC contacts

conductor section (mm ²)	conductor slot ø A (mm)	stripping length (mm)
0,14-0,37	0,9	7,5
0,5	1,1	7,5
0,75	1,3	7,5
1,0	1,45	7,5
1,5	1,8	7,5
2,5	2,2	7,5
3,0	2,55	7,5
4,0	2,85	7,5

Wire diameter: up to 4,7 mm.

For basic or high thickness gold plating, please refer to page F.13.

It is recommended to use the crimping tools and removal tools homologated by ILME (please see page F.23)

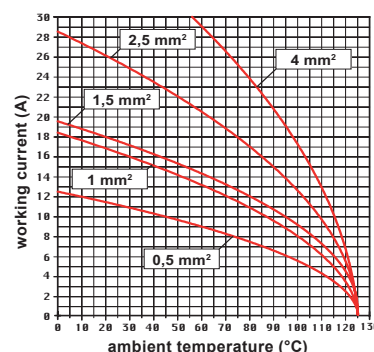
Materials

Insert	polycarbonate (PC)
UL 94 flame rating	V-0
Colour	pebble grey, RAL 7032
Contacts	copper alloy, silver ● and gold ● plated


CIF Q05 2.4
 PCB adapter
 Page D.4

CR CPQ
 Coding pins
 Page G.3

Compact 21.21 enclosures	Pages
Heavy-Duty Applications	
Thermoplastic	A.46-50
Thermoplastic with metal lever	A.53-55
Metallic	A.56-64
Aggressive Environments	
Metallic W-TYPE	A.72-75
Metallic E-Xtreme®	A.76-77
Metallic IP68 high protection	A.78-81
Specialized Applications	
EMC (Electromagnetic Shielding)	A.84-89
Hygienic series for food and beverage	A.94-96



CQ 05 inserts max. current load derating diagram

Inserts for applications with temperatures up to 180 °C available on request

 Can also be used partially fitted with 4 mm² section contacts



CQY 05

16 A 230/400 V

size **21.21**
5 poles + ⊕


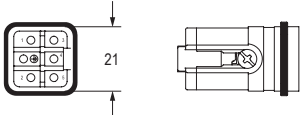

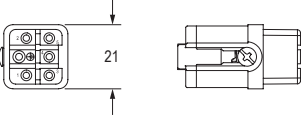
Tool-less connection – AXYR®

EN 61984 rating	16 A 230 / 400 V 4 kV 3
Rated voltage (UL / CSA)	600 V
Insulation resistance	≥ 10 GΩ
Contact resistance	≤ 3 mΩ
Ambient temperature limit	-40 °C ... +100 °C
Mechanical life (cycles)	≥ 500

CE UK (pending: EAC)

(pending: CQC, DNV and BV)

ALUS ECBT2.E115072 | ECBT8.E115072

Item	Description	Part No.	Dimension
	Male inserts with male contacts Spring/AXYR® push-in connection	CQYM 05	
	Female inserts with female contacts Spring/AXYR® push-in connection	CQYF 05	

CQY

A



Watch our clip

Materials

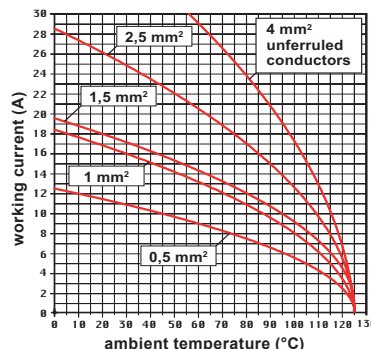
Insert	polycarbonate (PC)
UL 94 flame rating	V-0
Colour	pebble grey, RAL 7032
Contacts	built-in, copper alloy, silver ● plated

Wiring information

Wires cross sectional area	0,25 mm ² - 4 mm ² (AWG 24-12)
- unprepared	0,25 mm ² - 2,5 mm ² (AWG 24-14)
- prepared	9...11 mm
Stripping length	

Wire diameter: up to 5 mm.

Compact 21.21 enclosures	Pages
Heavy-Duty Applications	
Thermoplastic	A.46-50
Thermoplastic with metal lever	A.53-55
Metallic	A.56-64
Aggressive Environments	
Metallic W-TYPE	A.72-75
Metallic E-Xtreme®	A.76-77
Metallic IP68 high protection	A.78-81
Specialized Applications	
EMC (Electromagnetic Shielding)	A.84-89
Hygienic series for food and beverage	A.94-96



CQY 05 inserts max. current load derating diagram

CQ 07

10 A 400 V


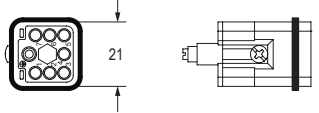
size **21.21**
7 poles + ⊕

Crimp connection

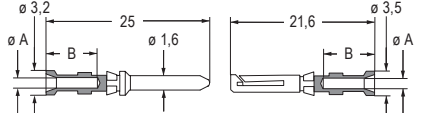


EN 61984 rating	10 A 400 V 6 kV 3
Rated voltage (UL / CSA)	600 V
Insulation resistance	≥ 10 GΩ
Contact resistance	≤ 3 mΩ
Ambient temperature limit	-40 °C ... +125 °C
Mechanical life (cycles)	≥ 500



ECB2.E115072 | ECBT8.E115072
PVVA2.E506437 | PVVA8.E506437

Item	Description	Part No.	Dimension
	Male inserts for male contacts Without contacts, including PE (to be ordered separately) Pre-leading FMLB screw-type PE contact (PE connection for unprepared wires only)	CQM 07	

	Female inserts for female contacts Without contacts, including PE (to be ordered separately) Pre-leading FMLB screw-type PE contact (PE connection for unprepared wires only)	CQF 07	
---	---	------------------------	---

10 A crimp contacts		Male	Female	
section (mm ²)	section (AWG)			
0,14-0,37	26-22	 CDMA 0.3	CDFA 0.3	
0,5	20	CDMA 0.5	CDFA 0.5	
0,75	18	CDMA 0.7	CDFA 0.7	
1	18	CDMA 1.0	CDFA 1.0	
1,5	16	CDMA 1.5	CDFA 1.5	
2,5	14	CDMA 2.5	CDFA 2.5	
		 CDMD 0.3	CDFD 0.3	
0,14-0,37	26-22	CDMD 0.5	CDFD 0.5	
0,5	20	CDMD 0.7	CDFD 0.7	
0,75	18	CDMD 1.0	CDFD 1.0	
1	18	CDMD 1.5	CDFD 1.5	
1,5	16	CDMD 2.5	CDFD 2.5	

Wiring information, CD contacts

conductor section (mm ²)	conductor slot ø A (mm)	stripping length B (mm)
0,14-0,37	0,9	8
0,5	1,1	8
0,75	1,3	8
1,0	1,45	8
1,5	1,8	8
2,5	2,2	6

Wire diameter: up to 3,8 mm.


For basic or high thickness gold plating, please refer to page F.16.


For stamped crimp contacts (SD series), please refer to page F.18.

It is recommended to use the crimping tools and removal tools homologated by ILME (please see page F.23)

Materials

Insert	polycarbonate (PC)
UL 94 flame rating	V-0
Colour	pebble grey, RAL 7032
Contacts	copper alloy, silver ● and gold ● plated

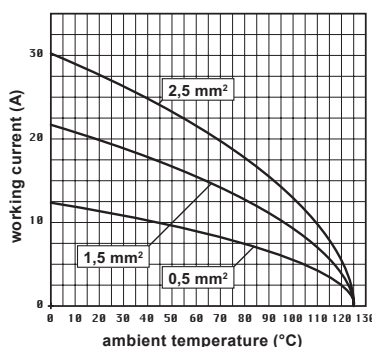
 **CIF Q07 2.4**
PCB adapter
Page D.4

 **CR Q..07**
Coding pins
Page G.4

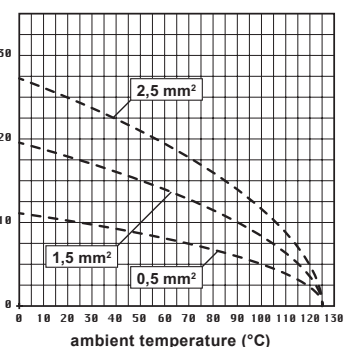
Compact 21.21 enclosures	Pages
Heavy-Duty Applications	
Thermoplastic	A.46-50
Thermoplastic with metal lever	A.53-55
Metallic	A.56-64
Aggressive Environments	
Metallic W-TYPE	A.72-75
Metallic E-Xtreme®	A.76-77
Metallic IP68 high protection	A.78-81
Specialized Applications	
EMC (Electromagnetic Shielding)	A.84-89
Hygienic series for food and beverage	A.94-96

Inserts already supplied with stainless steel fixing screw with gasket, which ensures IP66 / IP67 / IP69 degree of protection

CQ 07 inserts max. current load derating diagram, turned contacts



CQ 07 inserts max. current load derating diagram, stamped contacts



CQ 12

10 A 400 V

size **21.21**
12 poles + ⊕

Crimp connection

ISO 23570-3 standard and DESINA® specification compliant



EN 61984 rating	10 A 400 V 6 kV 3
	10 A 400 / 690 V 6 kV 2
Rated voltage (UL / CSA)	600 V
Insulation resistance	≥ 10 GΩ
Contact resistance	≤ 3 mΩ
Ambient temperature limit	-40 °C ... +125 °C
Mechanical life (cycles)	≥ 500



ECBT2.E115072 | ECBT8.E115072
PVVA2.E506437 | PVVA8.E506437

Item	Description	Part No.	Dimension
	Male inserts for male contacts Without contacts, including PE (to be ordered separately) PE screw connection for unprepared wires only	CQM 12	

	Female inserts for female contacts Without contacts, including PE (to be ordered separately) PE screw connection for unprepared wires only	CQF 12	
--	--	------------------------	--

10 A crimp contacts		Male	Female	
section (mm ²)	section (AWG)			
0,14-0,37	26-22	CDMA 0.3	CDFA 0.3	
0,5	20	CDMA 0.5	CDFA 0.5	
0,75	18	CDMA 0.7	CDFA 0.7	
1	18	CDMA 1.0	CDFA 1.0	
1,5	16	CDMA 1.5	CDFA 1.5	
2,5	14	CDMA 2.5	CDFA 2.5	
0,14-0,37	26-22	CDMD 0.3	CDFD 0.3	
0,5	20	CDMD 0.5	CDFD 0.5	
0,75	18	CDMD 0.7	CDFD 0.7	
1	18	CDMD 1.0	CDFD 1.0	
1,5	16	CDMD 1.5	CDFD 1.5	
2,5	14	CDMD 2.5	CDFD 2.5	

Wiring information, CD contacts

conductor section (mm ²)	conductor slot ø A (mm)	stripping length B (mm)
0,14-0,37	0,9	8
0,5	1,1	8
0,75	1,3	8
1,0	1,45	8
1,5	1,8	8
2,5	2,2	6

Wire diameter: up to 3,8 mm.

For basic or high thickness gold plating, please refer to page F.16.

It is recommended to use the crimping tools and removal tools homologated by ILME (please see page F.23)

Materials

Insert	polycarbonate (PC)
UL 94 flame rating	V-0
Colour	pebble grey, RAL 7032
Contacts	copper alloy, silver ● and gold ● plated

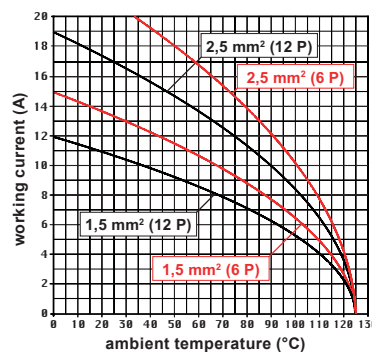
CQ 12 CIF
 Special inserts
 Page D.6

CR Q12
 Coding pins
 Page G.3

CR BDE
 Bridges for delta connections
 Page G.16

CR BST
 Bridges for star connections
 Page G.17

Compact 21.21 enclosures	Pages
Heavy-Duty Applications	
Thermoplastic	A.46-50
Thermoplastic with metal lever	A.53-55
Metallic	A.56-64
Aggressive Environments	
Metallic W-TYPE	A.72-75
Metallic E-Xtreme®	A.76-77
Metallic IP68 high protection	A.78-81
Specialized Applications	
EMC (Electromagnetic Shielding)	A.84-89
Hygienic series for food and beverage	A.94-96



CQ 12 inserts max. current load derating diagram

Inserts already supplied with stainless steel fixing screw with gasket, which ensures IP66 / IP67 / IP69 degree of protection

CQ 21

6,5 A 50 V_{AC}/120 V_{DC}

size **21.21**

21 poles + ⊕

Crimp connection

EN 61984 rating	6,5 A 50 V_{AC}/ 120 V_{DC} 0,8 kV 3
Rated voltage (UL / CSA)	250 V
Insulation resistance	≥ 10 GΩ
Contact resistance	≤ 4 mΩ
Ambient temperature limit	-40 °C ... +125 °C
Mechanical life (cycles)	≥ 500



ILME® ECBT2.E115072 | ECBT8.E115072

Item	Description	Part No.	Dimension
	Male inserts for male contacts Without contacts (to be ordered separately) Pole no. 9 is set forward to obtain pre-leading contact	CQM 21	

	Female inserts for female contacts Without contacts (to be ordered separately) Pole no. 9 is set forward to obtain pre-leading contact	CQF 21	
--	---	------------------------	--

5 A crimp contacts		Male	Female	
section (mm ²)	section (AWG)			
0,08-0,21	28-24	silver CIMA 0.2	CIFA 0.2	
0,13-0,33	26-22	CIMA 0.3	CIFA 0.3	
0,33-0,52	22-20	CIMA 0.5	CIFA 0.5	
0,08-0,21	28-24	gold CIMD 0.2	CIFD 0.2	
0,13-0,33	26-22	CIMD 0.3	CIFD 0.3	
0,33-0,52	22-20	CIMD 0.5	CIFD 0.5	

Wiring information, CI contacts

conductor section (mm ²)	conductor slot ø A (mm)	stripping length (mm)
0,08-0,21	0,64	4
0,13-0,33	0,9	4
0,33-0,52	1,12	4

Wire diameter: up to 1,7 mm.

For basic or high thickness gold plating, please refer to page F.17.

For stamped crimp contacts (SD series), please refer to page F.19.

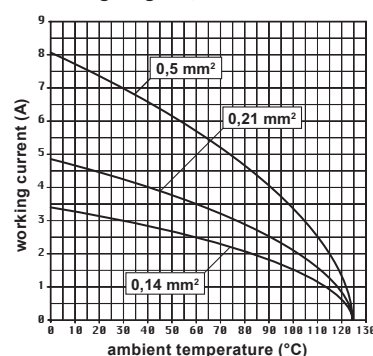
It is recommended to use the crimping tools and removal tools homologated by ILME (please see page F.23)

Materials

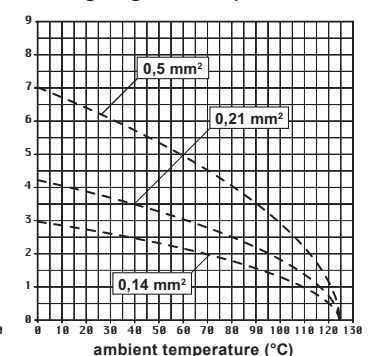
Insert	polycarbonate (PC)
UL 94 flame rating	V-0
Colour	pebble grey, RAL 7032
Contacts	copper alloy, silver ● and gold ● plated

Compact 21.21 enclosures	Pages
Heavy-Duty Applications	
Thermoplastic	A.46-50
Thermoplastic with metal lever	A.53-55
Metallic	A.56-64
Aggressive Environments	
Metallic W-TYPE	A.72-75
Metallic E-Xtreme®	A.76-77
Metallic IP68 high protection	A.78-81
Specialized Applications	
EMC (Electromagnetic Shielding)	A.84-89
Hygienic series for food and beverage	A.94-96

CQ 21 inserts max. current load derating diagram, turned contacts



CQ 21 inserts max. current load derating diagram, stamped contacts





A

CK and CKSH series

Easy wiring in a compact space



CR K03, CR K04R and CR K04G coding pins

CK and JK inserts series overview

These small but versatile connector inserts sized 21.21 are available with both screw termination technology (CK and JK series) and with tool-less and skill-independent **SQUICH® termination technology** (CKSH series).

Contacts' wiring is simple and fast, thanks to the presence – also on the protective earth terminal – of the SQUICH® actuator push buttons, whose colours (orange and green for PE) guarantee further visual help in identifying their function.

- > **CKF /M 03** with 3P + ⊕ – 230 V / 400 V rated voltage, up to 10 A current-carrying capacity;
- > **CKF /M 04** with 4P + ⊕ – 230 V / 400 V rated voltage, up to 10 A current-carrying capacity;
- > **CKFD /MD 03** and **CKFD /MD 04** inserts with 3P + ⊕ and 4P + ⊕ – 230 V / 400 V rated voltage, up to 10 A current-carrying capacity with gold-plated contacts;
- > **JKF /M 03** and **JKF /M 04** inserts with 3P + ⊕ and 4P + ⊕ – 230 V / 400 V rated voltage, up to 10 A current-carrying capacity with tin-plated contacts.
- > The terminals connections for the female and male inserts are made via screws (in accordance with IEC 60999-1 standard) for up to **2,5 mm² conductors**.



Watch our clip

CKSH SQUICH® inserts series overview

Requiring no wiring tool and no special wire preparation, the **CKSH** inserts offer excellent conductor fastening with great resistance to strong vibrations. Each push button safely allows the insertion of a measuring probe, even upon the connector being wired and under load, and is featured with a side slot for the possible spring terminal re-open using a simple 0,5 × 3 mm flat-blade screwdriver. The conductor entries are on the top rear of the connector insert, providing **vertical straight terminations**.

Whilst, screw-type CK inserts have lateral conductor entries and terminal screws on the top rear. Connecting capacity of terminals is from **0,14 mm² to 2,5 mm²** (26 to 14 AWG) for unprepared conductors. Use of prepared conductors (terminated with crimped ferrule) is up to **1,5 mm²** (16 AWG).

KEY FEATURES



> Easy wiring in compact size



> With coding pins



> Rear top entry for an easier wiring



> For solid or flexible wires and for crimped ferrules



- > **CKSHF /M 03** with 3P + ⊕ – 400 V rated voltage up to 10 A current-carrying capacity;
- > **CKSHF /M 04** with 4P + ⊕ – 400 V rated voltage up to 10 A current-carrying capacity.



3

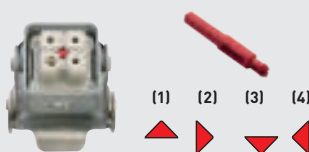


4

FOCUS

The CK / CKSH inserts adopt the proprietary optional coding system to prevent mismatching in case of multiple connectors installed close to each other. This coding system does not alter the mating face: connectors not using it are fully backwards mating compatible with former

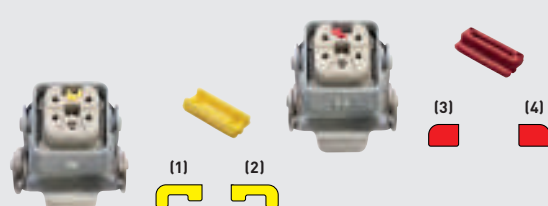
- > **CR K03** version, for connectors 3P + ⊕
4 possible positions by 90° rotation



CODING options for CK / CKSH series

products. With various combinations of coding pins available, it is possible to safely install up to 4 connectors of the same type but with different functions side-by-side.

- > **CR K04** version, for connectors 4P + ⊕
Each pin has 2 possible specular insertion positions



CK 03/CK 04

10 A 230/400 V

size **21.21**

3 poles + ⊕

4 poles + ⊕


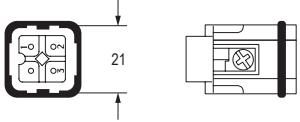

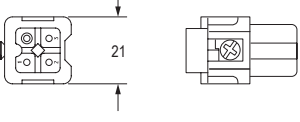

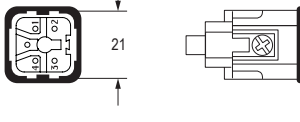

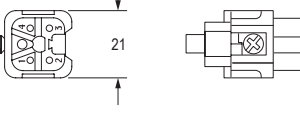
Screw connection

EN 61984 rating	10 A 230 / 400 V 4 kV 3
	10 A 400 / 690 V 4 kV 2
Rated voltage (UL / CSA)	600 V
Insulation resistance	≥ 10 GΩ
Contact resistance	≤ 2 mΩ
Ambient temperature limit	-40 °C ... +100 °C
Mechanical life (cycles)	≥ 500

CE UK EAC



ECBT2.E115072 | ECBT8.E115072

Item	Description	Part No.	Dimension
	3 poles male inserts with male contacts Distinctive colours: white and black Can be mated with CKSH inserts	CKM 03 CKM 03 N	
	3 poles female inserts with female contacts Distinctive colours: white and black Can be mated with CKSH inserts Can be mounted into the straight bulkhead housings CK I from the rear	CKF 03 CKF 03 N	
	4 poles male inserts with male contacts Distinctive colours: white and black Can be mated with CKSH inserts	CKM 04 CKM 04 N	
	4 poles female inserts with female contacts Distinctive colours: white and black Can be mated with CKSH inserts Can be mounted into the straight bulkhead housings CK I from the rear	CKF 04 CKF 04 N	

Materials

Insert	polyphenylene ether + polystyrene (PPE + PS)
UL 94 flame rating	V-1
Colour	
- CK...	white, RAL 7035
- CK...N	black, RAL 9005
Contacts	built-in, copper alloy, silver ● plated

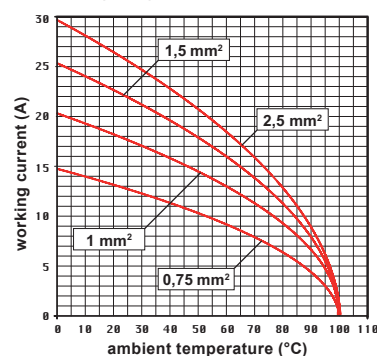
Wiring information

Wires cross sectional area	0,75 mm ² - 2,5 mm ² (AWG 18-14)
Stripping length	6 mm
Terminal screw torque	0,5 Nm (4.4 lb.in)

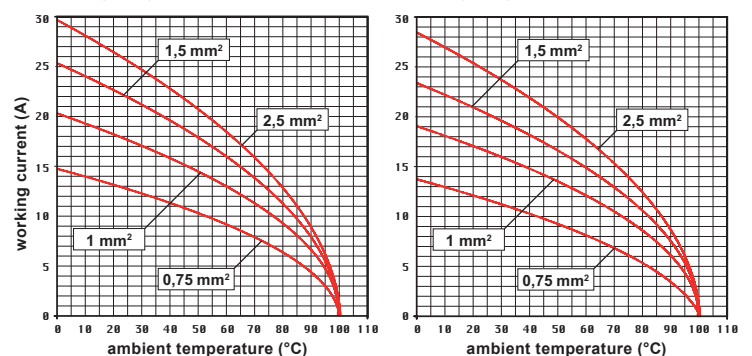
	CR K03 Coding pins Page G.2		CR K04R / K04G Coding pins Page G.2
---	--	---	--

Compact 21.21 enclosures	Pages
Heavy-Duty Applications	
Thermoplastic	A.46-50
Thermoplastic with metal lever	A.53-55
Metallic	A.56-64
Aggressive Environments	
Metallic W-TYPE	A.72-75
Metallic E-Xtreme®	A.76-77
Metallic IP68 high protection	A.78-81
Specialized Applications	
EMC (Electromagnetic Shielding)	A.84-89
Hygienic series for food and beverage	A.94-96

CK 03 inserts max. current load derating diagram



CK 04 inserts max. current load derating diagram





JK 03 / JK 04

10 A 230/400 V

size **21.21**

3 poles + ⊕


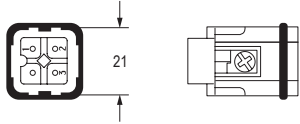

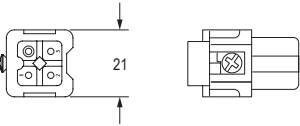

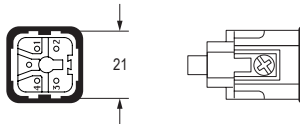

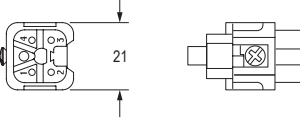
4 poles + ⊕

Screw connection

EN 61984 rating	10 A 230 / 400 V 4 kV 3
	10 A 400 / 690 V 4 kV 2
Rated voltage (UL / CSA)	600 V
Insulation resistance	≥ 10 GΩ
Contact resistance	≤ 2 mΩ
Ambient temperature limit	-40 °C ... +100 °C
Mechanical life (cycles)	≥ 200



ECBT2.E115072 | ECBT8.E115072

Item	Description	Part No.	Dimension
	Male inserts with male contacts	JKM 03	
	Female inserts with female contacts Can be mounted into the straight bulkhead housings CK I from the rear	JKF 03	
	Male inserts with male contacts	JKM 04	
	Female inserts with female contacts Can be mounted into the straight bulkhead housings CK I from the rear	JKF 04	

Materials

Insert	polyphenylene ether + polystyrene (PPE + PS)
UL 94 flame rating	V-1
Colour	white, RAL 7035
Contacts	built-in, copper alloy, tin ● plated

Wiring information

Wires cross sectional area	0,75 mm ² - 2,5 mm ² (AWG 18-14)
Stripping length	6 mm
Terminal screw torque	0,5 Nm (4.4 lb.in)



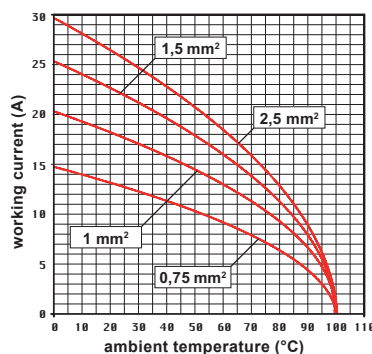
CR K03
Coding pins
Page [G.2](#)



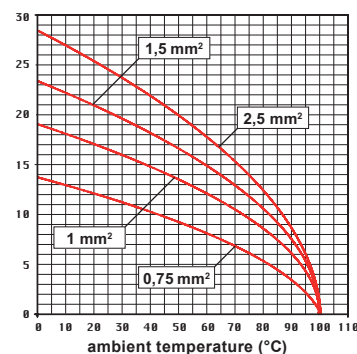
CR K04R / K04G
Coding pins
Page [G.2](#)

Compact 21.21 enclosures	Pages
Heavy-Duty Applications	
Thermoplastic	A.46-50
Thermoplastic with metal lever	A.53-55
Metallic	A.56-64
Aggressive Environments	
Metallic W-TYPE	A.72-73
Metallic E-Xtreme®	A.76-77
Metallic IP68 high protection	A.78-81
Specialized Applications	
EMC (Electromagnetic Shielding)	A.84-89
Hygienic series for food and beverage	A.94-96

JK 03 inserts max. current load derating diagram



JK 04 inserts max. current load derating diagram



Do not use inserts with tin plated contacts coupled with inserts with gold plated contacts.

CKD 03/CKD 04

10 A 230/400 V

size **21.21**

3 poles + ⊕

4 poles + ⊕


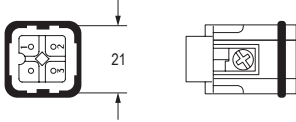

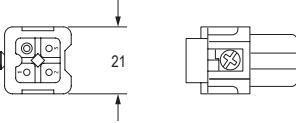

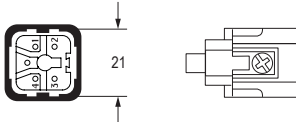

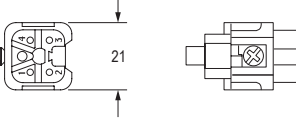
Screw connection

EN 61984 rating	10 A 230 / 400 V 4 kV 3
	10 A 400 / 690 V 4 kV 2
Rated voltage (UL / CSA)	600 V
Insulation resistance	≥ 10 GΩ
Contact resistance	≤ 2 mΩ
Ambient temperature limit	-40 °C ... +100 °C
Mechanical life (cycles)	≥ 500

CE UK EAC



ECBT2.E115072 | ECBT8.E115072

Item	Description	Part No.	Dimension
	Male inserts with male contacts	CKMD 03	
	Female inserts with female contacts Can be mounted into the straight bulkhead housings CK I from the rear	CKFD 03	
	Male inserts with male contacts	CKMD 04	
	Female inserts with female contacts Can be mounted into the straight bulkhead housings CK I from the rear	CKFD 04	

Materials

Insert	polyphenylene ether + polystyrene (PPE + PS)
UL 94 flame rating	V-1
Colour	white, RAL 7035
Contacts	built-in copper alloy, gold ● plated

Wiring information

Wires cross sectional area	0,75 mm ² - 2,5 mm ² (AWG 18-14)
Stripping length	6 mm
Terminal screw torque	0,5 Nm (4.4 lb.in)



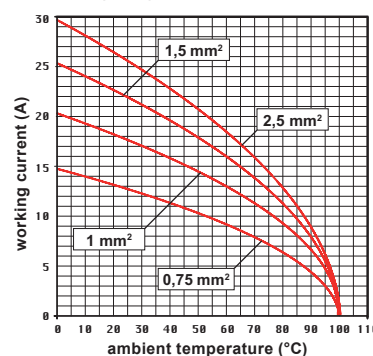
CR K03
Coding pins
Page [G.2](#)



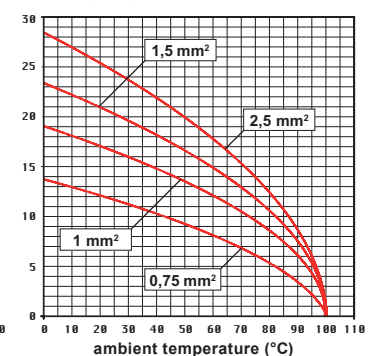
CR K04R / K04G
Coding pins
Page [G.2](#)

Compact 21.21 enclosures	Pages
Heavy-Duty Applications	
Thermoplastic	A.46-50
Thermoplastic with metal lever	A.53-55
Metallic	A.56-64
Aggressive Environments	
Metallic W-TYPE	A.72-75
Metallic E-Xtreme®	A.76-77
Metallic IP68 high protection	A.78-81
Specialized Applications	
EMC (Electromagnetic Shielding)	A.84-89
Hygienic series for food and beverage	A.94-96

CKD 03 inserts max. current load derating diagram



CKD 04 inserts max. current load derating diagram





CKSH 03/CKSH 04

10 A 400 V

size **21.21**

3 poles + ⊕

4 poles + ⊕

Tool-less connection – SQUICH®

EN 61984 rating	10 A 400 V 4 kV 3
	10 A 690 V 4 kV 2
Rated voltage (UL / CSA)	600 V
Insulation resistance	≥ 10 GΩ
Contact resistance	≤ 3 mΩ
Ambient temperature limit	-40 °C ... +125 °C
Mechanical life (cycles)	≥ 500



CBUS ECBT2.E115072 | ECBT8.E115072

Item	Description	Part No.	Dimension
	Male inserts with male contacts Spring clamp connections with actuator button Can be mated with CK inserts	CKSHM 03	
	Female inserts with female contacts Spring clamp connections with actuator button Can be mated with CK inserts	CKSHF 03	
	Male inserts with male contacts Spring clamp connections with actuator button Can be mated with CK inserts	CKSHM 04	
	Female inserts with female contacts Spring clamp connections with actuator button Can be mated with CK inserts	CKSHF 04	



Watch our clip

Materials

Insert	polycarbonate (PC)
UL 94 flame rating	V-0
Colour	pebble grey, RAL 7032
Contacts	built-in, copper alloy, silver ● plated

Wiring information

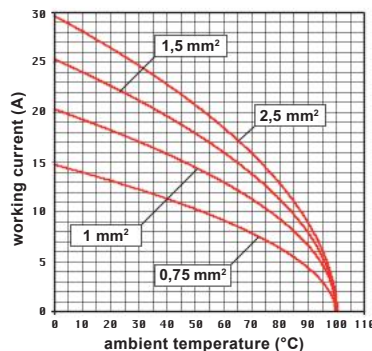
Wires cross sectional area	
- unprepared	0,14 mm ² - 2,5 mm ² (AWG 26-14)
- prepared	up to 1,5 mm ² (AWG 16)
Stripping length	9...11 mm

CR K03
Coding pins
Page [S.2](#)

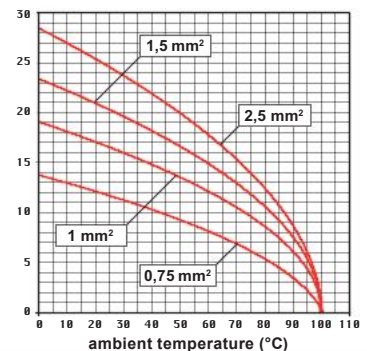
CR K04R / K04G
Coding pins
Page [S.2](#)

Compact 21.21 enclosures	Pages
Heavy-Duty Applications	
Thermoplastic	A.46-50
Thermoplastic with metal lever	A.53-55
Metallic	A.56-64
Aggressive Environments	
Metallic W-TYPE	A.72-75
Metallic E-Xtreme®	A.76-77
Metallic IP68 high protection	A.78-81
Specialized Applications	
EMC (Electromagnetic Shielding)	A.84-89
Hygienic series for food and beverage	A.94-96

CKSH 03 inserts max. current load derating diagram



CKSH 04 inserts max. current load derating diagram



CD and CDY series



The **CD** and **CDY** inserts are high-density multipole connectors offering the option of using removable crimp contacts (CD series) and tool-less **AXYR**[®] termination technology (CDY series).

In the same compact 21.21 size, two different polarities are available: 7P + ⊕ and 8P without PE connection for SELV (Safety Extra Low Voltage) applications, coded to avoid incorrect cross-mating.

CD series overview

The inserts are compatible with the CD crimp contacts series and are silver- or gold-plated. The PE connection for size 21.21 **CD 07** is a pass-through (crimp) connection that does not provide equipotential bonding to the earth to a possible metal connector enclosure. Hence, an additional safety coding has been implemented to avoid the insertion of the inserts in metal enclosures (only possible in insulation enclosures).

The connectors cover applications for rated voltage up to 250 V_{AC/DC} in Pollution Degree 3 (industrial environment) when

- > **CDF /M 07** with 7P + ⊕ – 250 V_{AC/DC} rated voltage, up to 10 A current-carrying capacity
- > **CDF /M 08** with 8P – 50 V_{AC} / 120 V_{DC} rated voltage (SELV), up to 10 A current-carrying capacity

fully equipped with contacts and for rated currents up to 10 A per pole (derating diagram shows actual current carrying capacity as a function of the number of poles, conductor size, and ambient temperature).





Watch our clip

CDY series overview

The **AXYR**[®] termination technology is implemented here as the equivalent version of the above-introduced 10 A current CDF /M 07 and CDF /M 08 crimp inserts. By offering a considerably compact spring push-in termination, these **AXYR**[®] variants provide an additional tool-less option in the popular 21.21 square size, when more than the five contacts of CQ 05 and CQY 05 are required and the investment in the crimping technology is not justified.

These models, CDY series, provide interchangeability, i.e., the highest level of compatibility, implying intermountability and intermateability, with the corresponding crimp versions, respectively CDF /M 07 and CDF /M 08. The mating faces of these 8P and 7P + ⊕ **AXYR**[®] connector inserts are also differently polarized to avoid cross-mating of different polarities.

- > **CDYF /M 07** with 7P + ⊕ – 250 V_{AC/DC} rated voltage, up to 10 A current-carrying capacity;
- > **CDYF /M 08** with 8P – 50 V rated voltage (SELV), up to 10 A current-carrying capacity.

The inserts are equipped with **AXYR**[®] spring push-in technology whose actuator button is required only for the release of the connection or for opening the terminal when using stranded unprepared wires or solid or prepared wires with cross-sectional area < 0,75 mm² / 18 AWG.

The 7-pole **CDYF /M 07 AXYR**[®] versions having a rated voltage of 250 V_{AC/DC} and pass-through PE connection, are properly keyed to fit insulating enclosures only (like the CDF /M 07 crimp ones).

KEY FEATURES

- > **Compatible wire cross-section:**
 - 0,14 mm² to 1,5 mm² (AWG 26-16) for prepared flexible conductors
 - 0,14 mm² to 2,5 mm² (AWG 24-14) for unprepared solid or flexible conductors
- > **Conductors stripping length:** 9...11 mm
- > **Max diameter of wire sheathing or ferrule funnel:** 3,8 mm



CDY 07

> **GREEN PE actuator button**



CDY 08

> **Terminal opening** for optimized conductors insertion (either prepared or unprepared)

- ☑ **CDY 07 and CDY 08** can be easily distinguished by the presence on the CDY 07 inserts of a **green-coloured PE actuator button**, while all buttons of the CDY 08 are orange-coloured.

FOCUS

Special voltages for CD series

As for any series of connector inserts for crimped connections, the polarity is intended as "up to", always possibly fitting a connector insert with a reduced number of crimped connections, suiting the specific application. In this regard, the CD series connector inserts can be used at specific (higher) voltages.

If all the contacts are used, CD 07 connector inserts may be used with voltage up to 250 V (first column) Pollution Degree 3 in accordance with IEC 61984 standard. If the number of contacts is reduced and the contacts assigned accordingly, these connectors may be used at 500 V (second column) Pollution Degree 3.

This is possible because the decrease in the number of contacts leads to less restrictive clearances (insulating distances in air) and creepage distances (insulating distances along the surface).

For use up to **250 V**
Pollution Degree 3

CD 07
7P + ⊕



For use up to **500 V**
Pollution Degree 3

CD 07
3P + ⊕



contacts side - front view

- working contact
- without contact
- F female insert
- M male insert

CD 07

10 A 250 V

size **21.21**
7 poles + ⊕

Crimp connection

EN 61984 rating	10 A 250 V 4 kV 3
	10 A 230 / 400 V 4 kV 2
Rated voltage (UL / CSA)	600 V
Insulation resistance	≥ 10 GΩ
Contact resistance	≤ 3 mΩ
Ambient temperature limit	-40 °C ... +125 °C
Mechanical life (cycles)	≥ 500



ILME ECBT2.E115072 | ECBT8.E115072

Item	Description	Part No.	Dimension
	Male inserts for male contacts Without contacts (to be ordered separately)	CDM 07 CDM 07 N	

	Female inserts for female contacts Without contacts (to be ordered separately)	CDF 07 CDF 07 N	
	Can be mounted into the straight bulkhead housings CK I from the rear		

10 A crimp contacts		Male	Female	
section (mm ²)	section (AWG)			
0,14-0,37	26-22	CDMA 0.3	CDFA 0.3	
0,5	20	CDMA 0.5	CDFA 0.5	
0,75	18	CDMA 0.7	CDFA 0.7	
1	18	CDMA 1.0	CDFA 1.0	
1,5	16	CDMA 1.5	CDFA 1.5	
2,5	14	CDMA 2.5	CDFA 2.5	
		silver		
0,14-0,37	26-22	CDMD 0.3	CDFD 0.3	
0,5	20	CDMD 0.5	CDFD 0.5	
0,75	18	CDMD 0.7	CDFD 0.7	
1	18	CDMD 1.0	CDFD 1.0	
1,5	16	CDMD 1.5	CDFD 1.5	
2,5	14	CDMD 2.5	CDFD 2.5	
		gold		

Wiring information, CD contacts

conductor section (mm ²)	conductor slot ø A (mm)	stripping length B (mm)
0,14-0,37	0,9	8
0,5	1,1	8
0,75	1,3	8
1,0	1,45	8
1,5	1,8	8
2,5	2,2	6

Wire diameter: up to 3,8 mm.

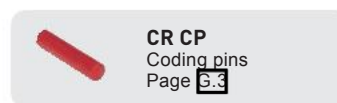
For basic or high thickness gold plating, please refer to page [E.16](#)

For stamped crimp contacts (SD series), please refer to page [E.18](#)

It is recommended to use the crimping tools and removal tools homologated by ILME (please see page [E.23](#))

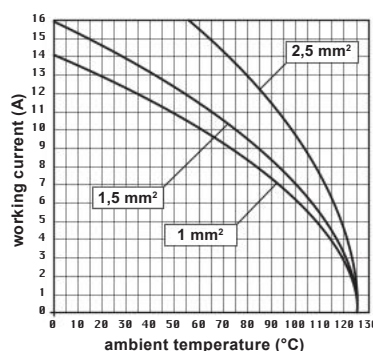
Materials

Insert	polycarbonate (PC)
UL 94 flame rating	V-0
Colour	
- CD...	pebble grey, RAL 7032
- CD...N	black, RAL 9005
Contacts	copper alloy, silver ● and gold ● plated

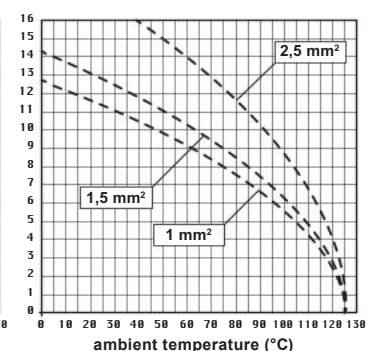


Compact 21.21 enclosures	Pages
Heavy-Duty Applications	
Thermoplastic	A.46-50
Thermoplastic with metal lever	A.53-55
Specialized Applications	
Hygienic series for food and beverage	A.94-96

CD 07 inserts max. current load derating diagram, turned contacts



CD 07 inserts max. current load derating diagram, stamped contacts



For applications requiring higher voltages, please see the special voltage application section on page [A.21](#)



CDY 07

10 A 250 V

size **21.21**
7 poles + ⊕

Tool-less connection – AXYR®

EN 61984 rating	10 A 250 V 4 kV 3
	10 A 230 / 400 V 4 kV 2
Rated voltage (UL / CSA)	600 V
Insulation resistance	≥ 10 GΩ
Contact resistance	≤ 3 mΩ
Ambient temperature limit	-40 °C ... +125 °C
Mechanical life (cycles)	≥ 500

CE UK (pending: EAC)

(pending: CQC, DNV and BV)

ALUS ECBT2.E115072 | ECBT8.E115072

Item	Description	Part No.	Dimension
	Male inserts with male contacts Spring/AXYR® push-in connection	CDYM 07	
	Female inserts with female contacts Spring/AXYR® push-in connection	CDYF 07	

CDY

A

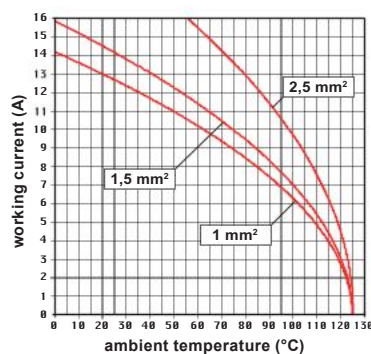


Watch our clip

Materials	
Insert	polycarbonate (PC)
UL 94 flame rating	V-0
Colour	pebble grey, RAL 7032
Contacts	built-in, copper alloy, silver ● plated

Wiring information	
Wires cross sectional area	0,14 mm ² - 2,5 mm ² (AWG 24-14)
- unprepared	0,14 mm ² - 1,5 mm ² (AWG 24-16)
- prepared	9...11 mm
Stripping length	
Wire diameter: up to 3,8 mm.	

Compact 21.21 enclosures	Pages
Heavy-Duty Applications	
Thermoplastic	A.46-50
Thermoplastic with metal lever	A.53-55
Specialized Applications	
Hygienic series for food and beverage	A.94-96



CDY 07 inserts max. current load derating diagram

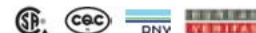
CD 08

10 A 50 V_{AC} / 120 V_{DC}

size **21.21**
8 poles

Crimp connection

EN 61984 rating	10 A 50 V _{AC} / 120 V _{DC}	0,8 kV 3
Rated voltage (UL / CSA)	50 V _{AC} / 120 V _{DC}	
Insulation resistance	≥ 10 GΩ	
Contact resistance	≤ 3 mΩ	
Ambient temperature limit	-40 °C ... +125 °C	
Mechanical life (cycles)	≥ 500	



ILME ECBT2.E115072 | ECBT8.E115072

Item	Description	Part No.	Dimension
	Male inserts for male contacts Without contacts (to be ordered separately)	CDM 08	
	Female inserts for female contacts Without contacts (to be ordered separately) Can be mounted into the straight bulkhead housings CK I from the rear	CDF 08	

10 A crimp contacts	section (mm ²)		section (AWG)		Male	Female	
	0,14-0,37	0,5	26-22	20			
	0,5	20			CDMA 0.3	CDFA 0.3	
	0,75	18			CDMA 0.5	CDFA 0.5	
	1	18			CDMA 0.7	CDFA 0.7	
	1,5	16			CDMA 1.0	CDFA 1.0	
	2,5	14			CDMA 1.5	CDFA 1.5	
	0,14-0,37	26-22			CDMD 0.3	CDFD 0.3	
	0,5	20			CDMD 0.5	CDFD 0.5	
	0,75	18			CDMD 0.7	CDFD 0.7	
	1	18			CDMD 1.0	CDFD 1.0	
	1,5	16			CDMD 1.5	CDFD 1.5	
2,5	14			CDMD 2.5	CDFD 2.5		

Wiring information, CD contacts

conductor section (mm ²)	conductor slot ø A (mm)	stripping length B (mm)
0,14-0,37	0,9	8
0,5	1,1	8
0,75	1,3	8
1,0	1,45	8
1,5	1,8	8
2,5	2,2	6

Wire diameter: up to 3,8 mm.

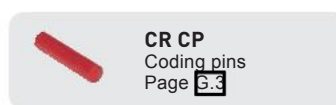
For basic or high thickness gold plating, please refer to page [E.16](#)

For stamped crimp contacts (SD series), please refer to page [E.18](#)

It is recommended to use the crimping tools and removal tools homologated by ILME (please see page [E.23](#))

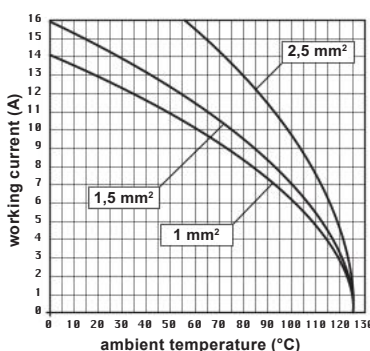
Materials

Insert	polycarbonate (PC)
UL 94 flame rating	V-0
Colour	pebble grey, RAL 7032
Contacts	copper alloy, silver ● and gold ● plated

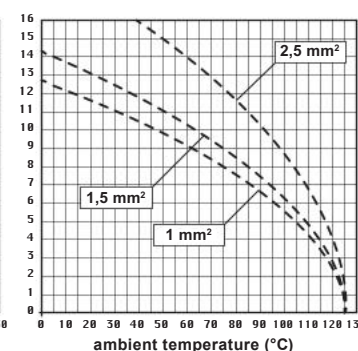


Compact 21.21 enclosures	Pages
Heavy-Duty Applications	
Thermoplastic	A.46-50
Thermoplastic with metal lever	A.53-55
Metallic	A.56-64
Aggressive Environments	
Metallic W-TYPE	A.72-75
Metallic E-Xtreme®	A.76-77
Metallic IP68 high protection	A.78-81
Specialized Applications	
EMC (Electromagnetic Shielding)	A.84-89
Hygienic series for food and beverage	A.94-96

CD 08 inserts max. current load derating diagram, turned contacts



CD 08 inserts max. current load derating diagram, stamped contacts





CDY 08

10 A 50 V_{AC} / 120 V_{DC}

size **21.21**
8 poles

Tool-less connection – AXYR®

EN 61984 rating	10 A 50 V _{AC} / 120 V _{DC}	0,8 kV 3
Rated voltage (UL / CSA)	50 V _{AC} / 120 V _{DC}	
Insulation resistance	≥ 10 GΩ	
Contact resistance	≤ 3 mΩ	
Ambient temperature limit	-40 °C ... +125 °C	
Mechanical life (cycles)	≥ 500	

(pending: CQC, DNV and BV)

ALUS ECBT2.E115072 | ECBT8.E115072

Item	Description	Part No.	Dimension
	Male inserts with male contacts Spring/AXYR® push-in connection	CDYM 08	
	Female inserts with female contacts Spring/AXYR® push-in connection	CDYF 08	

CDY

A

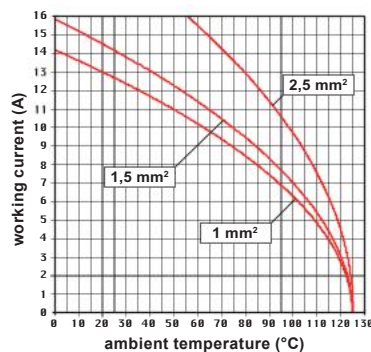


Watch our clip

Materials	
Insert	polycarbonate (PC)
UL 94 flame rating	V-0
Colour	pebble grey, RAL 7032
Contacts	built-in, copper alloy, silver ● plated

Wiring information	
Wires cross sectional area	
- unprepared	0,14 mm ² - 2,5 mm ² (AWG 24-14)
- prepared	0,14 mm ² - 1,5 mm ² (AWG 24-16)
Stripping length	9...11 mm
Wire diameter:	up to 3,8 mm.

Compact 21.21 enclosures	Pages
Heavy-Duty Applications	
Thermoplastic	A.46-50
Thermoplastic with metal lever	A.53-55
Metallic	A.56-64
Aggressive Environments	
Metallic W-TYPE	A.72-73
Metallic E-Xtreme®	A.76-77
Metallic IP68 high protection	A.78-81
Specialized Applications	
EMC (Electromagnetic Shielding)	A.84-89
Hygienic series for food and beverage	A.94-96



CDY 08 inserts max. current load derating diagram

DATA inserts in the 21.21 size



Sharing information through the creation of physical connections supports a vast number of applications and services.

As for power applications, copper is still one of the most widely used conductor in signal and data transmission, frequently paired to fibre optic specific installations for high speed data communication.

Whether part of a single device or a network, the demands for data communication are strongly dependent on the quality of these transmission medium and their terminal connectors.

Product Range

ILME data connectors play a crucial role in maintaining and guaranteeing the performance level of each application, making possible reliable data transmission and a stable connection in the commercial and industrial environment.

- > RJ45 connectors for the wiring of local networks according to the Ethernet IEEE 802.3, 100BASE-TX and 10GBASE-T standards
- > BUS coaxial connector providing shielding for the usage of standard CD, CC and CI contact series
- > USB 2.0 and 3.0 plugs and adapters
- > Fibre Optic SC plugs for multi-mode POF (Plastic Optic Fibre) or glass fibre
- > Complete connectors solutions for RJ45 and Service Interface

ILME products are designed to work inside correctly assembled inserts and enclosures. Patch cords and field assembly connectors are also available to ensure a wide-ranging answer to every specific customer need.

RJ45 for Ethernet CAT 5 and CAT 6_A

CJ and CJK inserts offer specific adapters for each RJ45 plug variant in the ILME product range, ultimately mounted inside suitable 21.21 enclosures.

KEY FEATURES

- > Compatible with 40 A "CX" series crimp contacts (including the PE pre-RJ45 **CAT 5 / CAT 5e** male crimp plugs and female couplers to be used in combination with CJ KM / CK KF inserts and equipped with two auxiliary contacts (2 A max);
- > RJ45 **CAT 6_A** male plugs and female couplers to be used in combination with CJK M / CKJ F inserts and available in crimp and IDC termination technology;
- > RJ45 universal adapter for an RJ45 patch cord with one or both RJ45 plug extremities already assembled;
- > Optional CR KC inserts coding pin.



CLK 04 SC adapter for Fibre Optics

The CLK 04 SC adapters enable the assembly of up to 4 SC fibre optic contacts: each female insert is provided with four ceramic (zirconia) type split alignment sleeves for minimal insertion loss (e.g. critical network connections) and best suitable for single-mode F/O cable connections.

As an optional accessory, metallic (phosphor bronze) split alignment sleeves are also available for more durable (less prone to cracking) applications, but less demanding precision alignment, thus most suitable for multi-mode fibre applications.

The fibre optic SC contacts (genderless, to be purchased separately) are available both for multi-mode glass fibres (50 / 125 μm or 62,5 / 125 μm) and single-mode glass fibre (E9 / 125 μm).

The fibre optic SC contacts are also available for the hard-clad silica (HCS) or polymer-clad fibre (PCF) 200 / 230 μm fibre optic cables and for the less demanding, with shorter transmission distance covered, but more cost-effective POF \varnothing 1 mm applications, available with crimp technique version (crimping tool required).




RJ45 inserts selection guide

Female inserts


Housings

RJ45 female/female coupler




CJK 8FT
(8 data contacts)

RJ45 female/IDC jack




CJK 8IFT
(8 data contacts, T568A coding) or
CJK 8B IFT
(8 data contacts, T568B coding) or
CJK 8P IFT
(8 data contacts, PROFINET coding)

RJ45 female/female coupler




CJ KF + CX 8 JF**
(8 data contacts)


RJ45 female/female coupler



CJ KF + CX 8/2 JF**
(8 data + 2 power contacts)



CJZAX 8 IA4
female/female RJ45
angled coupler
in a metal housing



CJZ 8 IA4N
female/female RJ45
angled coupler
in a plastic housing

Legend

- * hoods with M20 and PG11 side entry cannot be used with CX 8 J6IM, CJK 8FT/IFT, CLK and CJ inserts/adapters
- ** version with 4 data crossover wirings on request (CX4 JF, CX 4/2 JF)
- cannot be used with CJ KF adapter and CJK 8FT/IFT
- ▲ suitable cable glands AW M25PJ/1J/INJ
- suitable cable glands AW M25PJ/1J/INJ and CR CJK G gasket (already supplied with the CJK 8M universal patch cord adapter, see page A.33); cannot be used with CJ KF adapter
- ◇ cannot be used with CJ KF adapter




21.21 CK/MK plastic

 CK 03 I	 CK 03 IN	 CKX 03 I	 CKH 03 I
 MK IAP25	 MK AP25	 MKH IAP25	 MK AP20
 MK IAP25N	 MK AP25N	 MKH IAP25	 MK AP20
 MK VG20	 MK VGN20	 CKX 03 VG	 MKH VG20
 MK VG25	 MK VGN25	 MKH VG25	

Covers for hoods, with loop 

 CK 03 CXA	 CK 03 CXAN	 CKAH 03 CXA
---	---	---

21.21 CKA/MKA metal

 CKAX 03 I	 CKAX 03 ILS
 CKAX IAPS	 CKAX APS
 CKAX VGS	 MKAX IAP20
 MKAX AP20	 MKAX VG20
 CKAX 03 IA4	 MKAX AP25
 MKAX IAP25	 MKAX IVG20
 MKAX IF	 MKAX IFC
 MKAX VG25	
 CKAX 03 CXA (cover for hoods)	

21.21 CGK/MGK IP68

 CGK I	 CGK IAP13	 MGK IAP20	 MGK 2AP25
 CGK C/CGK C6 (cover for housings)			

Hoods

Male inserts

21.21 CK/MK plastic

MKGH V20
MKGH VA20*

CKG 03 V / CKG 03 VA* / CKG 03 VN / CKG 03 VAN*
MKG V20 / MKG VA20* / MKG VN20 / MKG VAN20*

Covers for housings, with eyelet

CKH 03 CS CKG 03 C CKG 03 CN

21.21 CKA/MKA metal

CKAG 03 V / CKAG 03 VA*
MKAG V20 / MKAG VA20*

CKAG 03 C
(cover for housings)

21.21 enlarged plastic/metal

MKGH V25 ▲
MKGH VA25 ▲

MKG V25 ▲ / MKG VA25 ▲
MKG VN25 ▲ / MKG VAN25 ▲

MKAG V25 ▲ / MKAG VA25 ▲

21.21 CGK/MGK IP68

CGK CG (cover for hoods) CGK V13 / MGK V20

CGK CG (cover for hoods) MGK V25

RJ45 connectors Cat. 6a

RJ45 male crimp plug
CJK 8MT + CX 8 J6M
(8 data contacts)

RJ45 male IDC plug
CJK 8IMT + CX 8 J6IM
(8 data contacts)

RJ45 connectors Cat. 5-5e

RJ45 male crimp plug
CJ KM + CX 4 JM
(4 data contacts)

RJ45 male crimp plug
CJ KM + CX 8 JM
(8 data contacts)

RJ45 male crimp plug
CJ KM + CX 4/2 JM
(4 data + 2 power contacts)

RJ45 male crimp plug
CJ KM + CX 6/2 JM
(6 data + 2 power contacts)

RJ45 male crimp plug
CJ KM + CX 4E JM
(4 data contacts Cat. 5e PROFINET)

CJK 8M
RJ45 universal
patch cord adapter

CR CJK G
special sealing
gasket included

CJ Cat. 5 / Cat. 5e Ethernet


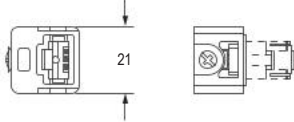

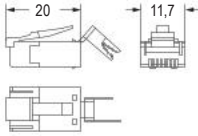

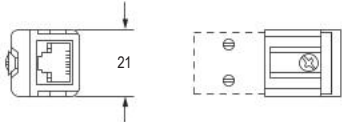

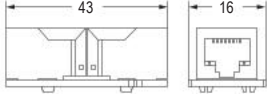
2,1 A 35 V_{AC}/50 V_{DC}

size **21.21**
1 seat for RJ45 connectors

Crimp connection

Rated voltage	35 V _{AC} / 50 V _{DC}
Rated current (at 70 °C)	2,1 A
Ambient temperature limit	-40 °C ... +120 °C

RAUS ECBT2.E115072 | ECBT8.E115072

Item	Description	Part No.	Dimension
	Adapter for RJ45 male connector Without RJ45 connector (to be ordered separately) To be used with hoods with glued gasket, DESINA® version	CJ KM	
	RJ45 plug, 4 data contacts RJ45 plug, 4 data contacts, Cat. 5e Profinet® RJ45 plug, 4 data + 2 power contacts RJ45 plug, 6 data + 2 power contacts RJ45 plug, 8 data contacts	CX 4 JM CX 4E JM CX 4/2 JM CX 6/2 JM CX 8 JM	
	Adapter for RJ45 female connector in fixed enclosures Without RJ45 connector (to be ordered separately) To be used only with mounting housing straight (CK..I)	CJ KF	
	RJ45 coupler jack, 4 data contacts* RJ45 coupler jack, 4 data + 2 power contacts* RJ45 coupler jack, 8 data contacts RJ45 coupler jack, 8 data + 2 power contacts * on request	CX 4 JF CX 4/2 JF CX 8 JF CX 8/2 JF	

Materials

Insert	polycarbonate (PC)
Screening	nickel-plated brass
UL 94 flame rating	V-0
Colour	white, RAL 7035

RJ45 insert, Class 5 Ethernet features, IDC terminals:

- for 0,22 mm² (AWG 24, 7-strands wire) data contacts **CX 4 JM**;
- for 0,14 mm² (AWG 26, 7-strands wire) or 0,22 mm² (AWG 24/7) data contacts **CX 4/2 JM**;
- for 0,34 mm² (AWG 22, 7-strands wire) or 0,38 mm² (AWG 22/19) power contacts;
- for 0,14 mm² (AWG 26, 7-strands wire) data contacts **CX 6/2 JM**;
- for 0,25 mm² (AWG 23, 19-strands wire) power contacts;
- for 0,14 mm² (AWG 26, 7-strands wire) data contacts **CX 8 JM**;
- for 0,34 mm² (AWG 22, 7-strands wire) data contacts **CX 4E JM**.

∅_{max} insulating conductors: 1 mm (data) and 1,4 mm (power and **CX 4E JM**)

∅_{max} complete cable: 7 mm (6,9 mm for **CX 8 JM**)

crimp pliers **CJPZ Y** and screened cable stripper **CJST**



CR KC
Coding pins
Page [9.11](#)

Compact 21.21 enclosures	Pages
Heavy-Duty Applications	
Thermoplastic	A.46-48 , 51-52*
Thermoplastic with metal lever	A.53-55
Metallic	A.56-63 , 65-66*
Aggressive Environments	
Metallic IP68 high protection	A.78-81
Specialized Applications	
Hygienic series for food and beverage	A.94-96*

* male inserts without gasket compatible only with hoods with glued gasket, **DESINA®** version

Inserts already supplied with stainless steel fixing screw with gasket, which ensures IP66/IP67/IP69 degree of protection



CJK Cat. 6_A Ethernet

1 A 50 V


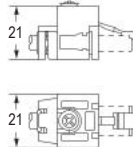

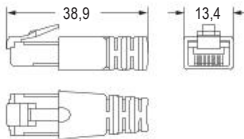

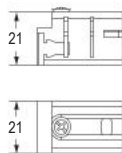

size 21.21

1 seat for RJ45 connectors

Crimp connection

EN 61984 rating	1 A 50 V 0,8 kV 3
Insulation resistance	≥ 10 GΩ
Ambient temperature limit	-40 °C ... +70 °C
Mechanical life (cycles)	≥ 500

RUUS ECBT2.E115072 | ECBT8.E115072

Item	Description	Part No.	Dimension
	Male insert for 1 RJ45 male crimp connector, 8 data contacts Without RJ45 connector (to be ordered separately) To be used with hoods with glued gasket, DESINA® version	CJK 8MT	
	RJ45 male crimp connector 8 data contacts	CX 8 J6M	
	Female insert with 1 RJ45 female-female coupler Cannot be used with angled bulkhead mounting housing (CK/CKA..IA/IA4) and angled mounting housing with M20 and Pg 11 cable entry	CJK 8FT	  CJK 8FT rear view


Materials	
Insert	polycarbonate (PC)
Shielding housing	nickel-plated brass
Housing finish	zinc die-cast
UL 94 flame rating	V-0
Colour	white, RAL 7035

CJK 8FT RJ45 female connectors, Cat. 6 Class E_A technical data:

- current carrying capacity at 50 °C: 1 A;
- PoE according to IEEE 802.3af: adequate for Power over Ethernet;
- generic cabling systems: ANSI/TIA/EIA-568-C.2; ISO/IEC 11801; EN50173-1; ISO/IEC 24702 and EN 61918;
- connectors: IEC 60603-7-5;
- 10 Gigabit Ethernet according to IEEE 802.3an: adequate for 10 Gigabit Ethernet;
- custom-designed cabling systems: PROFINET Installation Guideline;
- class E_A (channel): ISO/IEC 11801; EN 50173-1.

CX 8 J6M RJ45 male crimp connectors, Cat. 6_A technical data:

- conductor diameter: solid: 0,4 - 0,51 mm (AWG 26/1 - 24/1); stranded: 0,46 - 0,61 mm (AWG 27/7 - 24/7);
- insulation diameter: 0,85 - 1,05 mm;
- cable diameter: 5 - 7 mm;
- connectors: IEC 60603-7-51;
- crimp pliers: **CJPZ T**;
- screened cable stripper: **CJST**;
- 10 Gigabit Ethernet according to IEEE 802.3an: adequate for 10 Gigabit Ethernet;
- Cat. 6_A: ISO/IEC 11801; EN 50173-1; ANSI/TIA/EIA-568-C.2;
- class E_A: ISO/IEC 11801; EN 50173-1.

 **CR KC**
Coding pins
Page [3.11](#)

Compact 21.21 enclosures	Pages
Heavy-Duty Applications	
Thermoplastic	A.46-48 51-52*
Thermoplastic with metal lever	A.53-55
Metallic	A.56-63 65-66*
Aggressive Environments	
Metallic IP68 high protection	A.78-81
Specialized Applications	
Hygienic series for food and beverage	A.94-96*

* male inserts without gasket compatible only with hoods with glued gasket, **DESINA®** version

- Inserts already supplied with stainless steel fixing screw with gasket, which ensures IP66/IP67/IP69 degree of protection;
- it is recommended to fix the cable with cable tie.

CJK Cat. 6 / Cat. 6_A Ethernet

1 A 50 V


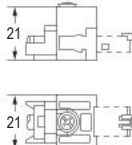

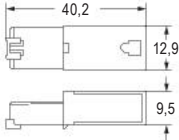

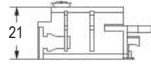

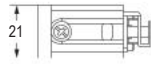


size **21.21**

1 seat for RJ45 IDC connectors

IDC connection

EN 61984 rating	1 A 50 V 0,8 kV 3
Insulation resistance	≥ 10 GΩ
Ambient temperature limit	-40 °C ... +70 °C
Mechanical life (cycles)	≥ 500


 ECBT2.E115072 | ECBT8.E115072

Item	Description	Part No.	Dimension
	Male insert for 1 RJ45 male IDC connector, 8 data contacts Without RJ45 connector (to be ordered separately) To be used with hoods with glued gasket, DESINA® version	CJK 8IMT	
	RJ45 male IDC connector 8 data contacts Cannot be used with angled enclosures	CX 8 J6IM	
	RJ45 female insert /IDC connection Cat. 6 _A contact coding according to T568A	CJK 8IFT	
	RJ45 female insert /IDC connection Cat. 6 _A contact coding according to T568B	CJK 8B IFT	
	RJ45 female insert /IDC connection Cat. 6 _A contact coding according to PROFINET Cannot be used with angled bulkhead mounting housing (CK/CKA..IA/IA4) and angled mounting housing with M20 and Pg 11 cable entry	CJK 8P IFT	 CJK..IFT rear view

Materials


Insert	polycarbonate (PC)
Shielding housing	nickel-plated brass
Housing finish	zinc die-cast
UL 94 flame rating	V-0
Colour	white, RAL 7035

CJK..IFT RJ45 female IDC connectors, Cat. 6_A technical data:

- conductor diameter: solid: 0,4 - 0,64 mm (AWG 26/1 - 22/1); stranded: 0,48 - 0,76 mm (AWG 26/7 - 22/7);
- current carrying capacity at 50 °C: 1 A;
- PoE according to IEEE 802.3af: adequate for Power over Ethernet;
- insulation diameter: 0,85 - 1,6 mm;
- generic cabling systems: ANSI/TIA/EIA-568-C.2; ISO/IEC 11801; EN50173-1; ISO/IEC 24702 and EN 61918;
- connectors: IEC 60603-7-5;
- 10 Gigabit Ethernet according to IEEE 802.3an: adequate for 10 Gigabit Ethernet;
- custom-designed cabling systems: PROFINET Installation Guideline;
- class E_A (channel): ISO/IEC 11801; EN 50173-1.

CX 8 J6IM RJ45 male IDC connectors, Cat. 6 Class E_A technical data:

- conductor diameter: solid: 0,41 - 0,64 mm (AWG 26/1 - 22/1); stranded: 0,48 - 0,76 mm (AWG 26/7 - 22/7);
- insulation diameter: 0,85 - 1,6 mm;
- cable diameter: 5,5 - 8,5 mm;
- connectors: IEC 60603-7-5;
- wrenches pliers: **CJPW K**;
- 10 Gigabit Ethernet according to IEEE 802.3an: adequate for 10 Gigabit Ethernet;
- custom-designed cabling systems: PROFINET Installation Guideline
- Cat. 6: ANSI/TIA/EIA-568-C.2
- Cat. 6_A: ISO/IEC 11801; DIN EN 50173-1;
- class E_A: ISO/IEC 11801; EN 50173-1.





CR KC
Coding pins
Page [S.11](#)

Compact 21.21 enclosures	Pages
Heavy-Duty Applications	
Thermoplastic	A.46-48 , 51-52*
Thermoplastic with metal lever	A.53-55
Metallic	A.56-63 , 65-66*
Aggressive Environments	
Metallic IP68 high protection	A.78-81
Specialized Applications	
Hygienic series for food and beverage	A.94-96*

* male inserts without gasket compatible only with hoods with glued gasket, **DESINA®** version

- Inserts already supplied with stainless steel fixing screw with gasket, which ensures IP66/IP67/IP69 degree of protection;
- it is recommended to fix the cable with cable tie.

PIN assignment

Pin n°	CJK 8IFT T568A according to TIA/EIA 568-C.2	CJK 8B IFT T568B according to TIA/EIA 568-C.2	CJK 8P IFT Profinet Industrial
1			
2	WH/GN	WH/OG	OG
3	GN	OG	WH
4	WH/OG	WH/GN	WH
5	BU	BU	—
6	WH/BU	WH/BU	—
7	OG	GN	BU
8	WH/BN	WH/BN	—
	BN	BN	—


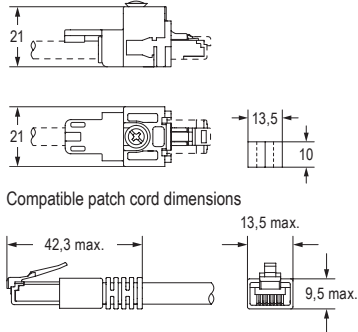

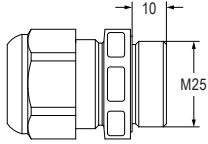

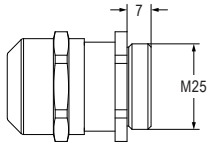


CJK 8M

size **21.21**
1 seat for RJ45 connectors

Insulation resistance	≥ 10 GΩ
Ambient temperature limit	-40 °C ... +70 °C
Mechanical life (cycles)	≥ 500


CAUS ECBT2.E115072 | ECBT8.E115072

Item	Description	Part No.	Dimension
	<p>Universal patch cord adapter</p> <p>CR CJK G gasket supplied with universal patch cord adapter</p> <p>To be used with hoods with glued gasket, DESINA® version</p>	CJK 8M	 <p>Compatible patch cord dimensions</p>
	<p>RAL 7035 Plastic cable gland</p> <p>RAL 9005 Plastic cable gland</p> <p>IP65 degree of protection; for higher degree we recommend the use of ASR B25 gasket. The cable glands are compatible with the use of the CR CJK G gasket shown above.</p>	AW M25IJ AW M25INJ	
	<p>Nickel plated brass cable gland</p> <p>The cable gland is compatible with the use of the CR CJK G gasket shown above.</p>	AW M25PJ	

Materials	
Insert	polycarbonate (PC)
UL 94 flame rating	V-0
Colour	white, RAL 7035



Tutorial



CR KC
Coding pins
Page G.11

Compact 21.21 enclosures	Pages
Heavy-Duty Applications	
Thermoplastic	A.46-48,51-52*
Thermoplastic with metal lever	A.53-55
Metallic	A.56-63,65-66*
Aggressive Environments	
Metallic IP68 high protection	A.78-81
Specialized Applications	
Hygienic series for food and beverage	A.94-96*

* male inserts without gasket compatible only with hoods with glued gasket, **DESINA®** version


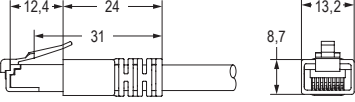

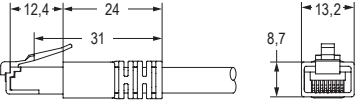

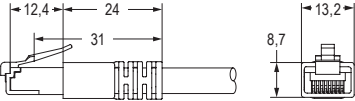

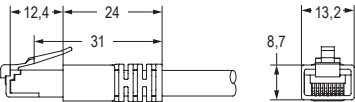

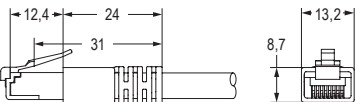
Inserts already supplied with stainless steel fixing screw with gasket, which ensures IP66/IP67/IP69 degree of protection

CJK A

CW / CWC

RJ45 patch cord Cat. 5, 6_A and 7

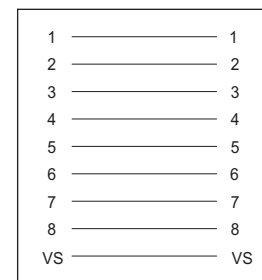
Ambient temperature limit -40 °C ... +75 °C

Item	Description	Part No.	L(m)	Dimension
	2×RJ45 male connector with 8 data contacts, S/FTP Cat. 6 _A cable 4×2 AWG 27/7 - Shielded Material PUR	CW 1 J2M87	1	
		CW 2 J2M87	2	
		CW 3 J2M87	3	
		CW 5 J2M87	5	
		CW 7.5J2M87	7,5	
		CW 10 J2M87	10	
	2×RJ45 cable plug SF/UTP Cat. 5 cable 4×2 AWG 26/7 - Shielded Material PUR	CW J5 1M	1	
		CW J5 2M	2	
		CW J5 3M	3	
		CW J5 5M	5	
		CW J5 7.5M	7,5	
		CW J5 10M	10	
	2×RJ45 cable plug SF/UTP Cat. 5 cable 4×2 AWG 26/7 - Shielded Material PVC	CWC J5 1M	1	
		CWC J5 2M	2	
		CWC J5 3M	3	
		CWC J5 5M	5	
		CWC J5 7.5M	7,5	
		CWC J5 10M	10	
	2×RJ45 cable plug S/FTP Cat. 6 _A cable 4×2 AWG 27/7 - Shielded Material PVC	CWC J6 1M	1	
		CWC J6 2M	2	
		CWC J6 3M	3	
		CWC J6 5M	5	
		CWC J6 7.5M	7,5	
		CWC J6 10M	10	
	1×M12 + 1×RJ45 cable plugs S/FTP Cat. 7 cable Over moulded IP67 to RJ45 plug IP20 4×2 AWG 26/7 Material PUR	CW XJ0.5M	0,5	
		CW XJ1M	1	
		CW XJ2M	2	
		CW XJ3M	3	
		CW XJ5M	5	
		CW XJ7.5M	7,5	
CW XJ10M	10			

Materials

Cable	hard polyurethane foam (PUR) polyvinyl chloride (PVC)
Shielding	nickel-plated brass
Colour	green, RAL 6018

CW wiring diagram


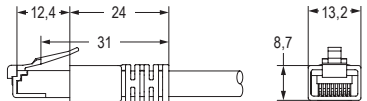

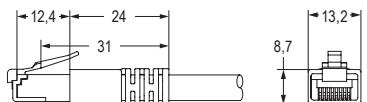

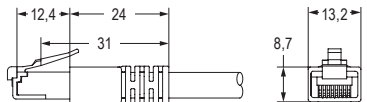




CWH

RJ45 patch cord Cat. 5e and 6_A

Ambient temperature limit -40 °C ... +75 °C

Item	Description	Part No.	L(m)	Dimension
	2×RJ45 cable plug S/FTP Cat. 5e wiring 1:1 cable Shielded	CWH JE 0.5M	0,5	
		CWH JE 1M	1	
		CWH JE 2M	2	
		CWH JE 3M	3	
		CWH JE 5M	5	
		CWH JE 7.5M	7,5	
		CWH JE 10M	10	
CWH JE 15M	15			
	2×RJ45 cable plug S/FTP Cat. 6 _A wiring 1:1 cable 1×90° - 1×180° cable root Shielded	CWH J6 0.5MA	0,5	
		CWH J6 1MA	1	
		CWH J6 2MA	2	
		CWH J6 3MA	3	
		CWH J6 5MA	5	
		CWH J6 7.5MA	7,5	
		CWH J6 10MA	10	
	2×RJ45 cable plug S/FTP Cat. 6 _A wiring 1:1 cable Shielded	CWH J6 0.25M	0,25	
		CWH J6 0.5M	0,5	
		CWH J6 1M	1	
		CWH J6 2M	2	
		CWH J6 3M	3	
		CWH J6 5M	5	
		CWH J6 7.5M	7,5	
		CWH J6 10M	10	
CWH J6 15M	15			

Materials

Cable	low-smoke zero-halogen (LSZH)
Shielding	nickel-plated brass
Colour	green, RAL 6018


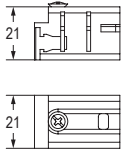

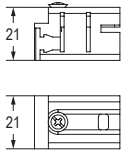

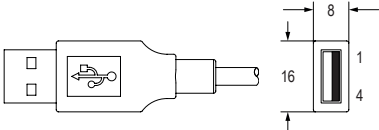
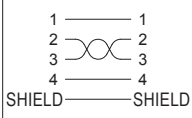
CUK

USB adapter

size **21.21**
1 seat for USB connector

Ambient temperature limit **-25 °C ... +80 °C**

ECBT2.E115072 | ECBT8.E115072

Item	Description	Part No.	L(m)	Dimension
	Female insert with USB 2.0 female-female coupler	CUK 2FT		
	Female insert with USB 3.0 female-female coupler	CUK 3FT		
	Patch cable USB-A/USB-A Patch cable USB-A/USB-A	CW 2 UAM CW 5 UAM	2 5	 

Materials

Insert	polycarbonate (PC)
UL 94 flame rating	V-0
Colour	white, RAL 7035

Compact 21.21 enclosures	Pages
Heavy-Duty Applications	
Thermoplastic	A.46-48,51-52*
Thermoplastic with metal lever	A.53-55
Metallic	A.56-63,65-66*
Aggressive Environments	
Metallic IP68 high protection	A.78-81
Specialized Applications	
Hygienic series for food and beverage	A.94-96*

* male inserts without gasket compatible only with hoods with glued gasket, **DESINA**® version

Inserts already supplied with stainless steel fixing screw with gasket, which ensures IP66/IP67/IP69 degree of protection

CX BD

10 A 50 V

size **21.21**

1 seat for shielded BUS coaxial connector + 2 aux. contacts

Crimp connection

EN 61984 rating	10 A 50 V 0,8 kV 3
Rated voltage (UL / CSA)	50 V
Insulation resistance	≥ 10 GΩ
Contact resistance (aux. contacts)	≤ 3 mΩ
Ambient temperature limit	-40 °C ... +70 °C
Mechanical life (cycles)	≥ 500

ECBT2.E115072 | ECBT8.E115072

Item	Description	Part No.	Dimension
	Adapter male insert with 1 seat for BUS connector and 2 seats for 10 A male contacts To be used with hoods with glued gasket, DESINA® version	CX 1/2 BDM	
	Adapter female insert with 1 seat for BUS connector and 2 seats for 10 A female contacts	CX 1/2 BDF	

10 A crimp contacts		Male	Female	
section (mm ²)	section (AWG)			
0,14-0,37	26-22	CDMA 0.3	CDFA 0.3	
0,5	20	CDMA 0.5	CDFA 0.5	
0,75	18	CDMA 0.7	CDFA 0.7	
1	18	CDMA 1.0	CDFA 1.0	
1,5	16	CDMA 1.5	CDFA 1.5	
2,5	14	CDMA 2.5	CDFA 2.5	
0,14-0,37	26-22	CDMD 0.3	CDFD 0.3	
0,5	20	CDMD 0.5	CDFD 0.5	
0,75	18	CDMD 0.7	CDFD 0.7	
1	18	CDMD 1.0	CDFD 1.0	
1,5	16	CDMD 1.5	CDFD 1.5	
2,5	14	CDMD 2.5	CDFD 2.5	

Wiring information, CD contacts

conductor section (mm ²)	conductor slot ø A (mm)	stripping length B (mm)
0,14-0,37	0,9	8
0,5	1,1	8
0,75	1,3	8
1,0	1,45	8
1,5	1,8	8
2,5	2,2	6

Wire diameter: up to 3,8 mm.

For basic or high thickness gold plating, please refer to page F.16.

It is recommended to use the crimping tools and removal tools homologated by ILME (please see page F.23)

Materials

Insert	polycarbonate (PC)
UL 94 flame rating	V-0
Colour	pebble grey, RAL 7032
Contacts	copper alloy, silver ● and gold ● plated

Both male and female inserts may accept any of the above shielded connectors of any gender, as far as the correct specular assignment is set on the mating connector

Extraction tool **CX BES** for BUS/coax shielded connectors see page F.60

CX 01 BC / CX..B
Shielded connectors
Pages C.63-65

Compact 21.21 enclosures	Pages
Heavy-Duty Applications	
Thermoplastic	A.46-48,51-52*
Thermoplastic with metal lever	A.53
Metallic	A.56-59,61,65-66*
Aggressive Environments	
Metallic IP68 high protection	A.78-81
Specialized Applications	
Hygienic series for food and beverage	A.94-96*

* male inserts without gasket compatible only with hoods with glued gasket, **DESINA®** version

- Inserts already supplied with stainless steel fixing screw with gasket, which ensures IP66/IP67/IP69 degree of protection;
- cannot be used in angled enclosures (IA / IAP and VA versions);
- cannot be used in M20 and Pg 11 cable entry enclosures.

Crimp connection

Insulating resistance	≥ 10 GΩ
Ambient temperature limit	-40 °C ... +70 °C
Cable operating temperature	-5 °C ... +55 °C
Cable storage temperature	-30 °C ... +70 °C
Cable installation temperature	-5 °C ... +50 °C
Cable flame retardancy according to:	IEC 60332-1
Halogen-free according to:	IEC 60754-2
Mechanical life (cycles)	≥ 500

ECBT2.E115072 | ECBT8.E115072

Item	Description	Part No.	L(m)	Dimension
	Adapter male insert for 4 SC contacts To be used with hoods with glued gasket, DESINA® version	CLK 04 SCM		
	Adapter female insert with ceramic sleeve, for 4 SC contacts	CLK 04 SCF		
	Adapter female insert with metal sleeve, for 4 SC contacts	CLK 04 SCF-H		
	SC contact for single-mode fibre E9/125 µm	CL 9/125 SC		
	SC contact for multi-mode fibre G50/125 µm or G62,5/125 µm	CL 125 SC		
	SC contact for 1 mm Ø POF	CL POF SC		
	SC duplex patch cord, single-mode fibre E9/125 µm, yellow cable	CW 1 SC9 CW 2 SC9 CW 3 SC9 CW 5 SC9 CW 10 SC9	1 2 3 5 10	
	SC duplex patch cord, multi-mode fibre G50/125 µm, orange cable	CW 1 SC50 CW 2 SC50 CW 3 SC50 CW 5 SC50 CW 10 SC50	1 2 3 5 10	
	SC duplex patch cord, multi-mode fibre G62,5/125 µm, orange cable	CW 1 SC62 CW 2 SC62 CW 3 SC62 CW 5 SC62 CW 10 SC62	1 2 3 5 10	

Materials

Insert	polycarbonate (PC)
Cable	polyvinyl chloride (PVC)
UL 94 flame rating	V-0
Colour	pebble grey, RAL 7032

Notes:

- Adapter inserts designed to be used with SC contacts;
- SC contact for SI (Step Index) FIBRE (HCS®) 200/230 µm: **CL 230 SC** (on request);
- base equipment for SC contact GI FIBRE: **CLKZ 125 SC** (If this application is required, please contact ILME S.p.A.)
- supplementary set for POF: **CLKZ POF**, to be ordered with **CLKZ 125 SC** (If this application is required, please contact ILME S.p.A.)

Compact 21.21 enclosures	Pages
Heavy-Duty Applications	
Thermoplastic	A.46-48 , 51-52*
Thermoplastic with metal lever	A.53-55
Metallic	A.56-63 , 65-66*
Aggressive Environments	
Metallic IP68 high protection	A.78-81
Specialized Applications	
Hygienic series for food and beverage	A.94-96*

* male inserts without gasket compatible only with hoods with glued gasket, **DESINA®** version

Inserts already supplied with stainless steel fixing screw with gasket, which ensures IP66/IP67/IP69 degree of protection


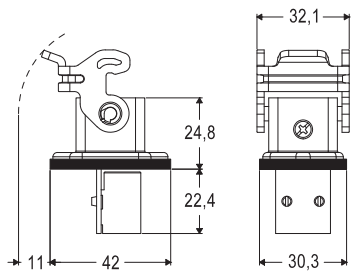

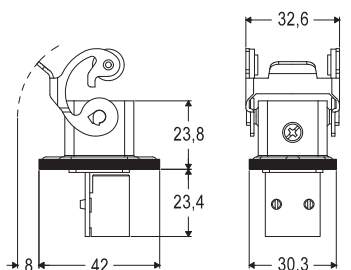

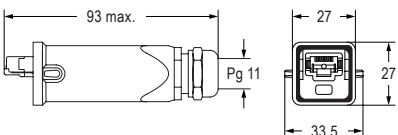

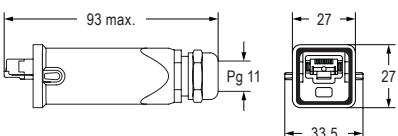


A

CJZ..I / CJZA..I**2,1 A 35 V_{AC} / 50 V_{DC}**size **21.21****1 seat for RJ45 connectors Cat. 5 Ethernet**

EN 60529	IP66 / IP67 / IP69
UL 50 / UL 50E	Type 12 / 4 / 4X
Rated voltage	35 V _{AC} / 50 V _{DC}
Rated current	2,1 A at 70 °C
Ambient temperature limit (RJ45 coupler and RJ45 plug)	-40 °C ... +120 °C
Ambient temperature limit (patch cord only)	-40 °C ... +70 °C


 ECBT2.E115072 | ECBT8.E115072 (CJZA only)

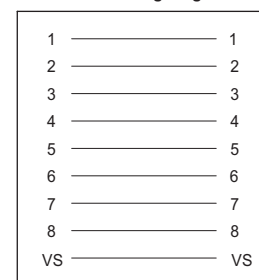
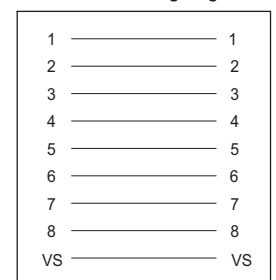
Item	Description	Part No.	L(m)	Dimension
	Female/female coupler connector in insulating enclosure (insert with 8 data contacts) cURus pending	CJZ 8 IN		
	Female/female coupler connector in metallic enclosure (insert with 8 data contacts)	CJZA 8 I		
	Patch cord with 2xRJ45 plug connectors, 8 data contacts in insulating enclosures	CWK 2 J2M8 CWK 5 J2M8 CWK 10 J2M8	2 5 10	
	Patch cord with 2xRJ45 plug connectors, 8 data contacts in metallic enclosures	CWKA 2 J2M8 CWKA 5 J2M8 CWKA 10 J2M8	2 5 10	

Materials

Insert	polycarbonate (PC)
Shielding	nickel-plated brass
Insulating enclosure	self-extinguishing thermoplastic
Metal enclosure	die-cast zinc alloy
UL 94 flame rating	V-0
Insert colour	white, RAL 7035
Insulating enclosure colour	jet black, RAL 9005
Metal enclosure colour	grey, RAL 7040


CR KC
Coding pins
Page G.11
Accessories

Accessories	Pages
CW J5..M Cat. 5 cable plug	A.34
CWC J5..M Cat. 5 cable plug	A.34

CJZ – CJZA wiring diagram**CWK – CWKA wiring diagram**


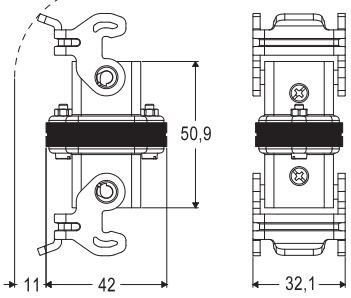

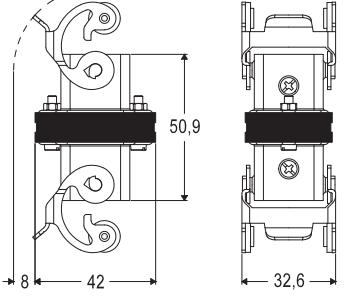
CYG

2,1 A 35 V_{AC}/50 V_{DC}

size **21.21**

2 seats for RJ45 connectors Cat. 5

EN 60529	IP66 / IP67 / IP69
UL 50 / UL 50E	Type 12 / 4 / 4X
Rated voltage	35 V _{AC} / 50 V _{DC}
Rated current	2,1 A at 70 °C
Ambient temperature limit	-40 °C ... +120 °C

Item	Description	Part No.	Dimension
	RJ45 coupler jack, within insulating housings 4 data contacts* 4 data + 2 power contacts* 8 data contacts 8 data + 2 power contacts * on request	CYG 4 JF CYG 4/2 JF CYG 8 JF CYG 8/2 JF	
	RJ45 coupler jack, within metallic housings 4 data contacts* 4 data + 2 power contacts* 8 data contacts 8 data + 2 power contacts * on request	CYG 4 JFA CYG 4/2 JFA CYG 8 JFA CYG 8/2 JFA	

Materials

Insert	polycarbonate (PC)
Shielding	nickel-plated brass
Insulating enclosure	self-extinguishing thermoplastic
Metal enclosure	die-cast zinc alloy
UL 94 flame rating	V-0
Insert colour	white, RAL 7035
Insulating enclosure colour	jet black, RAL 9005
Metal enclosure colour	grey, RAL 7040



CR KC
Coding pins
Page G.11


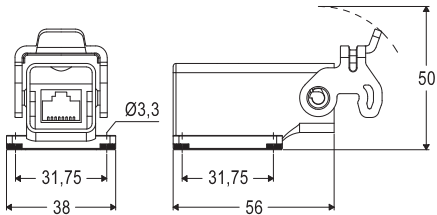

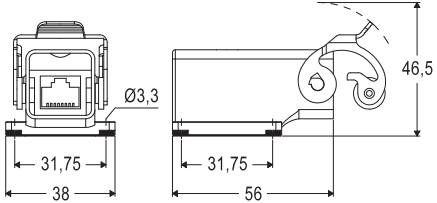

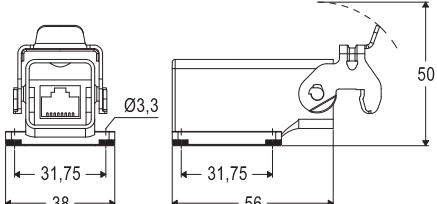

Accessories

Accessories	Pages
CW J5..M Cat. 5 cable plug	A.34
CWC J5..M Cat. 5 cable plug	A.34

CJZ..IA4/CJZA..IA4**2,1 A 35 V_{AC}/50 V_{DC}**size **21.21****1 seat for RJ45 coupler Cat. 5 Ethernet**

EN 60529	IP66 / IP67 / IP69
UL 50 / UL 50E	Type 12 / 4 / 4X
Rated voltage	35 V_{AC} / 50 V_{DC}
Rated current	2,1 A at 70 °C
Ambient temperature limit	-40 °C ... +120 °C
Mechanical life (cycles)	≥ 500

 ECBT2.E115072 | ECBT8.E115072 (CJZA only)

Item	Description	Part No.	Dimension
	Angled insulating bulkhead mounting housing with RJ45 coupler, 1 lever, fixing by 4 screws	CJZ 8 IA4N	
	Metallic angled bulkhead mounting housings with RJ45 coupler, with stainless steel lever	CJZAX 8 IA4	
	Metallic angled bulkhead mounting housings with RJ45 coupler, with stainless steel rigid lever	CJZAXX 8 IA4	
	Metallic angled bulkhead mounting housings with RJ45 coupler, with galvanized steel rigid lever	CJZA 8 IA4	

Materials

Insert	polycarbonate (PC)
Shielding	nickel-plated brass
Insulating enclosure	self-extinguishing thermoplastic
Metal enclosure	die-cast zinc alloy
UL 94 flame rating	V-0
Insert colour	white, RAL 7035
Insulating enclosure colour	jet black, RAL 9005
Metal enclosure colour	grey, RAL 7040



CR KC
Coding pins
Page G.11

Accessories	Pages
CW J5..M Cat. 5 cable plug	A.34
CWC J5..M Cat. 5 cable plug	A.34


ATR

service interface

EN 60529	
(ATR C22 only)	IP65
Ambient temperature limit	-40 °C ... +70 °C

Item	Description	Part No.	Dimension
	<p>Communication interface bulkhead IP65</p> <p>To be completed with either one of the following products</p>	ATR C22	
	RJ45 female /IDC connection Cat 6A, contact coding according T568A	AT 8IFT	
	RJ45 IDC jack with coding according T568B or PROFINET on request		
	RJ45 female /female coupler Cat.6	AT 8FT	
	USB 2.0 coupler F-F Type A	AT U2F	
	USB 3.0 coupler F-F Type A	AT U3F	
	LC-Duplex multi-mode adapter	AT LCMM	
	LC-Duplex single-mode adapter	AT LCSM	

Materials	
Housing	polyamide (PA)
Nut	polyamide (PA)
UL 94 flame rating	V-0
Bulkhead protective cap	EPDM
Elastic band/seal	EPDM



CW..LC..
 LC duplex patch cord for single-mode and multi-mode fibre optic
 Page C.85



Enclosures size 21.21 for Heavy-Duty Applications



The 21.21 enclosure series represents the ideal match for the same size compact and versatile connector inserts.

Industrial heavy-duty applications can benefit from a comprehensive product range in terms of installation possibilities (bulkhead-mounted, surface-mounted and cable-to-cable joints) and specific environment requirements.

Functional characteristics

Thanks to the inner coding key being differently shaped between metallic enclosures (trapezoidal cross-section) and insulating enclosures (rectangular cross-section), connector inserts size 21.21 having a floating PE contact (e.g. CDF/M 07) are prevented from fitting into metallic enclosures CKA-MKA, as they would not provide the required PE connection to the enclosure.

The corresponding outer coding keyway of all 21.21 inserts having the PE contact to guarantee bonding to earth to the metallic enclosure or those inserts deemed to be used only at SELV is similarly trapezoidal.

Thus, these inserts fit into all enclosures. Insulating enclosures size 21.21 accept all size 21.21 inserts.

The series features metallic and insulating enclosure variants, the latter light grey RAL 7035 or jet black RAL 9005, available with a single-block locking lever.

- Metallic enclosures made in zinc die-cast alloy, with epoxy-polyester thermosetting powder coating.
- Insulating enclosures made in self-extinguishing thermoplastic material.
- Gaskets in anti-aging, oil-resistant, grease-resistant and fuel-resistant NBR vinyl nitrile elastomer.
- ✓ **Type 12; Type 4 and 4X using the optional special fixing screw + gasket kit CKR 65 (enclosure type ratings equivalent to the NEMA 250 ones).**
- ✓ **IP44 degree of protection, IP66 / IP67 / IP69 by using the special fixing screw + gasket kit CKR 65 separately available, and suitable cable outlet device.**

21.21 series locking levers overview

KEY FEATURES

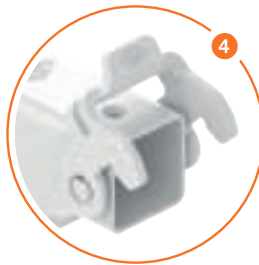
Zinc die-cast enclosures

- > Flexible stainless steel lever with riveted rolls **1** for optimal performance during several mating cycles.
- > Rigid galvanized steel **2** or rigid stainless steel lever **3** for securing large cable bundles.



Insulating enclosures

- > Self-extinguishing thermoplastic material lever **4**, standard fitting for all insulating 21.21 enclosures (CK / MK).
- > Flexible stainless steel lever with riveted rolls **5** (CKX / MKX).



FOCUS

Coding options

Optional colour coding clips, snap-on fixable to the lever body, made of insulating material in four different colours, are available to provide the possibility of correspondingly coding the mating counterpart hood, equipped with cable gland and correspondingly coloured coding rings made of thermoplastic elastomer. See pages A.68-69.



Thermoplastic – CK / MK


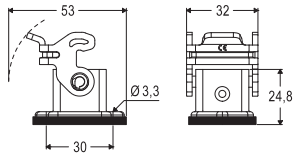

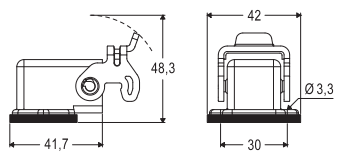

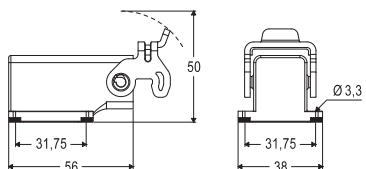

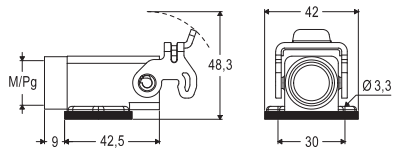

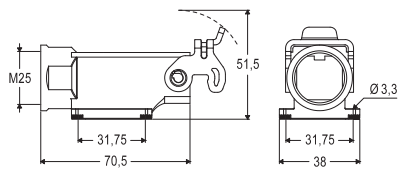
Housings – 1 lever

 size **21.21**
Heavy-Duty Applications


EN 60529	IP44
With CKR 65	IP66 / IP67 / IP69
UL 50 / UL 50E	Type 12
With CKR 65	Type 4 / 4X
Ambient temperature limits	-40 °C ... +125 °C
Mechanical life (cycles)	≥ 500

(pending: CQC, DNV and BV)

(pending: cURus)

Item	Description	Light grey	Jet black	Entry	Dimension
	Bulkhead mounting housings, 1 lever	CK 03 I	CK 03 IN		
	Angled bulkhead mounting housings, 1 lever Not suitable for CQ4 series inserts	CK 03 IA	CK 03 IAN		
	Angled bulkhead mounting housing, 1 lever, fixing by 4 screws	CK 03 IA4	CK 03 IA4N		
	Angled bulkhead mounting housings, 1 lever, with <u>open bottom flange</u> , with cable entry Not suitable for CQ4 series inserts	MK IAP20 CK 03 IAPS	MK IAPN20 CK 03 IAPNS	M20 Pg 11	
	Angled bulkhead mounting housing, 1 lever, with <u>open bottom flange</u> , M25 cable entry, fixing by 4 screws	MK IAP25	MK IAPN25	M25	

Compact 21.21 Inserts	Poles	Pages
CQ4 / CQ / CQY	40 A to 6,5 A	A.4-12
CK / JK / CKSH	10 A	A.16-19
CD / CDY	10 A	A.22-23
CD / CDY	10 A	A.24-25
CJ (RJ45)	1 A to 2,1 A	A.30-33
CUK (USB)	-	A.36
CX (BUS)	10 A	A.37
CLK (Fibre optics)	-	A.38

Note: to obtain the IP66 / IP67 / IP69 degree of protection it is necessary to replace the fixing screw supplied with all inserts, with the one with gasket included in the CKR 65 kit, to be purchased separately, except for the inserts listed below (already supplied with a fixing screw with gasket):

- CQF/M 07, CQF/M 12
- CJ KF
- CJK 8FT / 8IFT
- CUK 2FT / 3FT
- CX 1/2 BDF/M
- CLK 04 SCF / SCF-H / SCM

Accessories:


CKR 65
 gasket and screw kits for
 IP66 / IP67 / IP69
 Page A.67



Thermoplastic – CK / MK

Housings – 1 lever

size **21.21**

Heavy-Duty Applications

EN 60529	IP44
With CKR 65	IP66 / IP67 / IP69
UL 50 / UL 50E	Type 12
With CKR 65	Type 4 / 4X
Ambient temperature limits	-40 °C ... +125 °C
Mechanical life (cycles)	≥ 500



(pending: CQC, DNV and BV)

(pending: cURus)

Item	Description	Light grey	Jet black	Entry	Dimension
	Angled insulating surface mounting housing, 1 lever, with <u>closed bottom flange</u> . M25 cable entry, fixing by 4 screws	MK AP25	MK APN25	M25	

CK / MK

A

Compact 21.21 Inserts	Poles	Pages
CQ4 / CQ / CQY	40 A to 6,5 A	2 to 21 + ⊕
CK / JK / CKSH	10 A	3 to 4 + ⊕
CD / CDY	10 A	7 + ⊕
CD / CDY	10 A	8
CJ (RJ45)	1 A to 2,1 A	–
CUK (USB)	–	–
CLK (Fibre optics)	–	–

Note: to obtain the IP66 / IP67 / IP69 degree of protection it is necessary to replace the fixing screw supplied with all inserts, with the one with gasket included in the CKR 65 kit, to be purchased separately, except for the inserts listed below (already supplied with a fixing screw with gasket):

- CQF/M 07, CQF/M 12
- CJ KF
- CJK 8FT /8IFT
- CUK 2FT /3FT
- CLK 04 SCF /SCF-H /SCM

Accessories:



CKR 65
gasket and screw kits for IP66 / IP67 / IP69
Page A.67

Thermoplastic – CK / MK

Hoods and covers – 1 lever

size **21.21**
**Heavy-Duty
Applications**


EN 60529	IP44
With CKR 65	IP66 / IP67 / IP69
UL 50 / UL 50E	Type 12
With CKR 65	Type 4 / 4X
Ambient temperature limits	-40 °C ... +125 °C
Mechanical life (cycles)	≥ 500

CE UK

(pending: CQC, DNV and BV)

(pending: cURus)

Item	Description	Light grey	Jet black	Entry	Dimension
	Hoods, 1 lever, top entry Not suitable for CQ4 series inserts	MK VG20 CK 03 VGS	MK VGN20 CK 03 VGNS	M20 Pg 11	
	Hoods, 1 lever, top entry	MK VG25	MK VGN25	M25	
	Covers, 1 lever, with or without gasket For hoods with 2 pegs with loop	With gasket (for female inserts) CK 03 CX	Without gasket (for male inserts) CK 03 CXA		

CK 03 CXA(N) >
< CK 03 CX(N)

Compact 21.21 Inserts	Poles	Pages
CQ4 / CQ / CQY	40 A to 6,5 A	2 to 21 + ⊕
CK / JK / CKSH	10 A	3 to 4 + ⊕
CD / CDY	10 A	7 + ⊕
CD / CDY	10 A	8
CJ (RJ45)	1 A to 2,1 A	–
CUK (USB)	–	–
CX (BUS)	10 A	–
CLK (Fibre optics)	–	–

Note: to obtain the IP66 / IP67 / IP69 degree of protection it is necessary to replace the fixing screw supplied with all inserts, with the one with gasket included in the CKR 65 kit, to be purchased separately, except for the inserts listed below (already supplied with a fixing screw with gasket):

- CQF/M 07, CQF/M 12
 - CJ KF
 - CJK 8FT / 8IFT

- CUK 2FT / 3FT
 - CX 1/2 BDF/M
 - CLK 04 SCF / SCF-H / SCM

Accessories:


CKR 65
 gasket and screw kits for
 IP66 / IP67 / IP69
 Page A.67



Thermoplastic – CK / MK

size **21.21**

Hoods – 2 pegs

Heavy-Duty Applications

EN 60529	IP44
With CKR 65	IP66 / IP67 / IP69
UL 50 / UL 50E	Type 12
With CKR 65	Type 4 / 4X
Ambient temperature limits	-40 °C ... +125 °C
Mechanical life (cycles)	≥ 500



ALUS ECBT2.E115072 | ECBT8.E115072

Item	Description	Light grey	Jet black	Entry	Dimension
	Hoods, 2 pegs, side entry Not suitable for CQ4 series inserts	MK VA20 CK 03 VAS	MK VAN20 CK 03 VANS	M20 Pg 11	
	Hoods, 2 pegs, top entry Not suitable for CQ4 series inserts	MK V20 CK 03 VS	MK VN20 CK 03 VNS	M20 Pg 11	
	Hoods, 2 pegs, side entry	MK VA25	MK VAN25	M25	
	Hoods, 2 pegs, top entry	MK V25	MK VN25	M25	

CK / MK

A

Compact 21.21 Inserts	Poles	Pages
CQ4 / CQ / CQY	40 A to 6,5 A	A.4-12
CK / JK / CKSH	3 to 21 + ⊕	A.16-19
CD / CDY	7 + ⊕	A.22-23
CD / CDY	8	A.24-25

Note: to obtain the IP66 / IP67 / IP69 degree of protection it is necessary to replace the fixing screw supplied with all inserts, with the one with gasket included in the CKR 65 kit, to be purchased separately, except for the inserts listed below (already supplied with a fixing screw with gasket):

- CQF/M 07, CQF/M 12

Accessories:



CKR 65
gasket and screw kits for
IP66 / IP67 / IP69
Page A.67



Thermoplastic – CK / MK

Covers – 2 pegs

size **21.21**Heavy-Duty
Applications

EN 60529	IP44
With CKR 65	IP66 / IP67 / IP69
UL 50 / UL 50E	Type 12
With CKR 65	Type 4 / 4X
Ambient temperature limits	-40 °C ... +125 °C
Mechanical life (cycles)	≥ 500

CE UK
CAC[®] AUS ECBT2.E115072 | ECBT8.E115072

Item	Description	Light grey	Jet black	Dimension	
	Covers, 2 pegs, with or without gasket	With gasket (for female inserts)			
	For hoods with 1 lever with loop 	CK 03 CS	Without gasket (for male inserts)		CK 03 CAS
	Covers, 2 pegs, with or without gasket	With gasket (for female inserts)			
	For housings with 1 lever with eyelet 	CK 03 C	CK 03 CN		Without gasket (for male inserts)

CK / MK

A



Thermoplastic – CK / MK – DESINA®

size **21.21**

Housings – 1 lever

Heavy-Duty Applications

EN 60529	IP44
With CKR 65	IP66 / IP67 / IP69
UL 50 / UL 50E	Type 12
With CKR 65	Type 4 / 4X
Ambient temperature limits	-40 °C ... +125 °C
Mechanical life (cycles)	≥ 500



(pending: CQC, DNV and BV)

(pending: cURus)

Item	Description	Light grey	Jet black	Dimension
	Bulkhead mounting housings, 1 lever DESINA® version	CK 03 I	CK 03 IN	

CK / MK - DESINA®

A

Compact 21.21 Inserts	Poles	Pages
CQ4 / CQ / CQY	40 A to 6,5 A	2 to 21 + ☺
CK / JK / CKSH	10 A	3 to 4 + ☺
CD / CDY	10 A	7 + ☺
CD / CDY	10 A	8
CJ (RJ45)	1 A to 2,1 A	–
CUK (USB)	–	–
CX (BUS)	10 A	–
CLK (Fibre optics)	–	4

DESINA® version: suitable for DESINA® CJ, CUK, CLK, CX BD adapters for male inserts without gasket

Thermoplastic – CK / MK – DESINA®

 size **21.21**

Hoods and covers – 2 pegs

 Heavy-Duty
Applications


EN 60529	IP44
With CKR 65	IP66 / IP67 / IP69
UL 50 / UL 50E	Type 12
With CKR 65	Type 4 / 4X
Ambient temperature limits	-40 °C ... +125 °C
Mechanical life (cycles)	≥ 500



ECBT2.E115072 | ECBT8.E115072

Item	Description	Light grey	Jet black	Entry	Dimension
	Hoods, 2 pegs and glued gasket, side entry DESINA® version	MKG VA20 CKG 03 VA	MKG VAN20 CKG 03 VAN	M20 Pg 11	
	Hoods, 2 pegs and glued gasket, top entry DESINA® version	MKG V20 CKG 03 V	MKG VN20 CKG 03 VN	M20 Pg 11	
	Hoods, 2 pegs and glued gasket, side entry DESINA® version	MKG VA25	MKG VAN25	M25	
	Hoods, 2 pegs and glued gasket, top entry DESINA® version	MKG V25	MKG VN25	M25	
	Covers, 2 pegs and glued gasket DESINA® version For housings with 1 lever with eyelet	CKG 03 C	CKG 03 CN		

Compact 21.21 Inserts	Poles	Pages
CJ (RJ45)	1 A to 2,1 A	A.30-33
CUK (USB)	-	A.36
CX (BUS)	10 A	A.37
CLK (Fibre optics)	4	A.38

DESINA® version: suitable for DESINA® CJ, CUK, CLK, CX BD adapters for male inserts without gasket

Thermoplastic – CKX / MKX

size **21.21**

Housings – 1 metal lever

Heavy-Duty Applications

EN 60529	IP44
With CKR 65	IP66 / IP67 / IP69
UL 50 / UL 50E	Type 12
With CKR 65	Type 4 / 4X
Ambient temperature limits	-40 °C ... +125 °C
Mechanical life (cycles)	≥ 500

CE UK



RUUS ECBT2.E115072 | ECBT8.E115072

Item	Description	Light grey	Jet black	Entry	Dimension
	Bulkhead mounting housings, 1 stainless steel lever	CKX 03 I	CKX 03 IN		
	Angled bulkhead mounting housings, 1 stainless steel lever Not suitable for CQ4 series inserts	CKX 03 IA			
	Angled bulkhead mounting housings, 1 stainless steel lever, fixing by 4 screws	CKX 03 IA4			
	Angled bulkhead mounting housings, 1 stainless steel lever, with open bottom flange, with cable entry, with or without cable gland Not suitable for CQ4 series inserts	With cable gland CKX 03 IAP Without cable gland CKX 03 IAPS		Pg 11 Pg 11	
	Angled bulkhead mounting housings, 1 stainless steel lever, with open bottom flange, M25 cable entry, fixing by 4 screws	MKX IAP25		M25	

CKX / MKX

A

Compact 21.21 Inserts	Poles	Pages
CQ4 / CQ / CQY	40 A to 6,5 A	2 to 21 + ⊕
CK / JK / CKSH	10 A	3 to 4 + ⊕
CD / CDY	10 A	7 + ⊕
CD / CDY	10 A	8
CJ (RJ45)	1 A to 2,1 A	–
CUK (USB)	–	–
CX (BUS)	10 A	–
CLK (Fibre optics)	–	4

Note: to obtain the IP66 / IP67 / IP69 degree of protection it is necessary to replace the fixing screw supplied with all inserts, with the one with gasket included in the CKR 65 kit, to be purchased separately, except for the inserts listed below (already supplied with a fixing screw with gasket):

- CQF/M 07, CQF/M 12
- CJ KF
- CJK 8FT / 8IFT
- CUK 2FT / 3FT
- CX 1/2 BDF/M
- CLK 04 SCF / SCF-H / SCM

Accessories:

CKR 65 gasket and screw kits for IP66 / IP67 / IP69 Page [A.67](#)

Thermoplastic – CKX / MKX


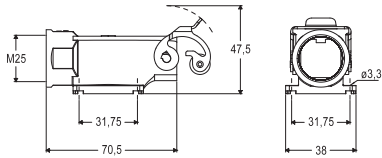
Housings – 1 metal lever

size **21.21**Heavy-Duty
Applications

EN 60529	IP44
With CKR 65	IP66 / IP67 / IP69
UL 50 / UL 50E	Type 12
With CKR 65	Type 4 / 4X
Ambient temperature limits	-40 °C ... +125 °C
Mechanical life (cycles)	≥ 500

CE UK
CA

ECBT2.E115072 | ECBT8.E115072

Item	Description	Light grey	Entry	Dimension
	Angled surface mounting housing, 1 stainless steel lever, with <u>closed bottom flange</u> , M25 cable entry, fixing by 4 screws	MKX AP25	M25	

CKX / MKX

A

Compact 21.21 Inserts	Poles	Pages
CQ4 / CQ / CQY	40 A to 6,5 A	2 to 21 + ⊕
CK / JK / CKSH	10 A	3 to 4 + ⊕
CD / CDY	10 A	7 + ⊕
CD / CDY	10 A	8
CJ (RJ45)	1 A to 2,1 A	–
CUK (USB)	–	–
CLK (Fibre optics)	–	–

Note: to obtain the IP66 / IP67 / IP69 degree of protection it is necessary to replace the fixing screw supplied with all inserts, with the one with gasket included in the CKR 65 kit, to be purchased separately, except for the inserts listed below (already supplied with a fixing screw with gasket):

- CQF/M 07, CQF/M 12
- CJ KF
- CJK 8FT / 8IFT
- CUK 2FT / 3FT
- CLK 04 SCF / SCF-H / SCM

Accessories:

CKR 65
gasket and screw kits for
IP66 / IP67 / IP69
Page A.67



Thermoplastic – CKX / MKX

size **21.21**

Hoods – 1 metal lever

Heavy-Duty Applications

EN 60529	IP44
With CKR 65	IP66 / IP67 / IP69
UL 50 / UL 50E	Type 12
With CKR 65	Type 4 / 4X
Ambient temperature limits	-40 °C ... +125 °C
Mechanical life (cycles)	≥ 500



CAIUS ECBT2.E115072 | ECBT8.E115072

Item	Description	Light grey	Entry	Dimension
	Hoods, 1 stainless steel lever, top entry, with or without cable gland	With cable gland CKX 03 VG	Pg 11	
	Not suitable for CQ4 series inserts	Without cable gland CKX 03 VGS	Pg 11	

CKX / MKX

A

Compact 21.21 Inserts	Poles	Pages
CQ4 / CQ / CQY	40 A to 6,5 A	2 to 21 + ⊕
CK / JK / CKSH	10 A	3 to 4 + ⊕
CD / CDY	10 A	7 + ⊕
CD / CDY	10 A	8
CJ (RJ45)	1 A to 2,1 A	–
CUK (USB)	–	–
CLK (Fibre optics)	–	–

Note: to obtain the IP66 / IP67 / IP69 degree of protection it is necessary to replace the fixing screw supplied with all inserts, with the one with gasket included in the CKR 65 kit, to be purchased separately, except for the inserts listed below (already supplied with a fixing screw with gasket):

- CQF/M 07, CQF/M 12
- CJK 8FT /8IFT
- CUK 2FT /3FT
- CLK 04 SCF /SCF-H /SCM

Accessories:



CKR 65
gasket and screw kits for IP66 / IP67 / IP69
Page A.67


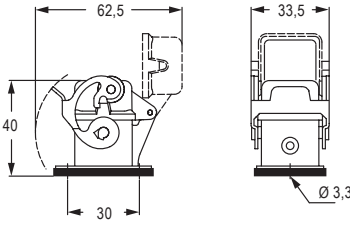

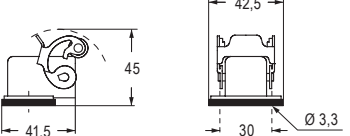

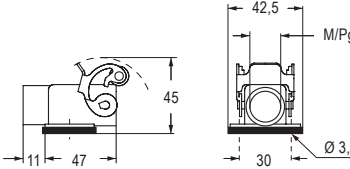
Metallic – CKA / MKA

Housings – 1 lever

size **21.21**Heavy-Duty
Applications

EN 60529	IP44
With CKR 65	IP66 / IP67 / IP69
UL 50 / UL 50E	Type 12
With CKR 65	Type 4 / 4X
Ambient temperature limits	-40 °C ... +125 °C
Mechanical life (cycles)	≥ 500

CE UK
CAC&A[®] ECBT2.E115072 | ECBT8.E115072

Item	Description	Part No.	With cover	Entry	Dimension
	Bulkhead mounting housings, 1 stainless steel lever, with or without self-closing cover	CKAX 03 I	For male inserts CKAX 03 ILSA For female inserts CKAX 03 ILS		
	Angled bulkhead mounting housings, 1 stainless steel lever Not suitable for CQ4 series inserts	CKAX 03 IA			
	Angled bulkhead mounting housings, 1 stainless steel lever, with cable entry, open or closed bottom flange Not suitable for CQ4 series inserts	Open bottom flange MKAX IAP20 CKAX 03 IAPS Closed bottom flange MKAX AP20 CKAX 03 APS	M20 Pg 11 M20 Pg 11		

Compact 21.21 Inserts	Poles	Pages
CQ4 / CQ / CQY	40 A to 6,5 A	2 to 21 + ☉
CK / JK / CKSH	10 A	3 to 4 + ☉
CD / CDY	10 A	8
CJ (RJ45)	1 A to 2,1 A	–
CUK (USB)	–	–
CX (BUS)	10 A	–
CLK (Fibre optics)	–	–

Note: to obtain the IP66 / IP67 / IP69 degree of protection it is necessary to replace the fixing screw supplied with all inserts, with the one with gasket included in the CKR 65 kit, to be purchased separately, except for the inserts listed below (already supplied with a fixing screw with gasket):

- CQF/M 07, CQF/M 12	- CUK 2FT /3FT
- CJ KF	- CX 1/2 BDF/M
- CJK 8FT /8IFT	- CLK 04 SCF /SCF-H /SCM

Accessories:

CKR 65
gasket and screw kits for
IP66 / IP67 / IP69
Page A.67



Metallic – CKA / MKA

size **21.21**

Hoods and covers – 1 lever

Heavy-Duty Applications

EN 60529	IP44
With CKR 65	IP66 / IP67 / IP69
UL 50 / UL 50E	Type 12
With CKR 65	Type 4 / 4X
Ambient temperature limits	-40 °C ... +125 °C
Mechanical life (cycles)	≥ 500



RUUS ECBT2.E115072 | ECBT8.E115072

Item	Description	Part No.	Entry	Dimension
	Hoods, 1 stainless steel lever, top entry Not suitable for CQ4 series inserts	MKAX VG20 CKAX 03 VGS	M20 Pg 11	
	Hoods, 1 stainless steel lever, top entry	MKAX VG25	M25	
	Covers, 1 stainless steel lever, with or without gasket For hoods with 2 pegs with loop	With gasket (for female inserts) CKAX 03 CX Without gasket (for male inserts) CKAX 03 CXA		

CKA / MKA

A

Compact 21.21 Inserts	Poles	Pages
CQ4 / CQ / CQY	40 A to 6,5 A	2 to 21 + ☺
CK / JK / CKSH	10 A	3 to 4 + ☺
CD / CDY	10 A	8
CJ (RJ45)	1 A to 2,1 A	–
CUK (USB)	–	–
CX (BUS)	10 A	–
CLK (Fibre optics)	–	–

Note: to obtain the IP66 / IP67 / IP69 degree of protection it is necessary to replace the fixing screw supplied with all inserts, with the one with gasket included in the CKR 65 kit, to be purchased separately, except for the inserts listed below (already supplied with a fixing screw with gasket):

- CQF/M 07, CQF/M 12
- CJ KF
- CJK 8FT /8IFT
- CUK 2FT /3FT
- CX 1/2 BDF/M
- CLK 04 SCF /SCF-H /SCM

Accessories:



CKR 65
gasket and screw kits for IP66 / IP67 / IP69
Page A.67

Metallic – CKA / MKA

Housings – 1 lever

size **21.21**
**Heavy-Duty
Applications**


EN 60529	IP44
With CKR 65	IP66 / IP67 / IP69
UL 50 / UL 50E	Type 12
With CKR 65	Type 4 / 4X
Ambient temperature limits	-40 °C ... +125 °C
Mechanical life (cycles)	≥ 500

CE UK

(pending: CQC, DNV and BV)

(pending: cURus)

Item	Description	Part No.	With cover	Entry	Dimension
	Bulkhead mounting housings, 1 galvanized steel rigid lever, with or without self-closing cover	CKA 03 I	For male inserts CKA 03 ILSA	For female inserts CKA 03 ILS	
	Angled bulkhead mounting housings, 1 galvanized steel rigid lever Not suitable for CQ4 series inserts	CKA 03 IA			
	Angled bulkhead mounting housings, 1 galvanized steel rigid lever, with cable entry, open or closed bottom flange Not suitable for CQ4 series inserts	Open bottom flange MKA IAP20 CKA 03 IAPS		M20 Pg 11	
		Closed bottom flange MKA AP20 CKA 03 APS		M20 Pg 11	

Compact 21.21 Inserts	Poles	Pages
CQ4 / CQ / CQY	40 A to 6,5 A	2 to 21 + ⊕
CK / JK / CKSH	10 A	3 to 4 + ⊕
CD / CDY	10 A	8
CJ (RJ45)	1 A to 2,1 A	–
CUK (USB)	–	–
CX (BUS)	10 A	–
CLK (Fibre optics)	–	–

Note: to obtain the IP66 / IP67 / IP69 degree of protection it is necessary to replace the fixing screw supplied with all inserts, with the one with gasket included in the CKR 65 kit, to be purchased separately, except for the inserts listed below (already supplied with a fixing screw with gasket):

- CQF/M 07, CQF/M 12 - CUK 2FT /3FT
 - CJ KF - CX 1/2 BDF/M
 - CJK 8FT /8IFT - CLK 04 SCF /SCF-H /SCM

Accessories:


CKR 65
gasket and screw kits for
IP66 / IP67 / IP69
Page A.67



Metallic – CKA / MKA

size **21.21**

Hoods – 1 lever

Heavy-Duty Applications



EN 60529	IP44
With CKR 65	IP66 / IP67 / IP69
UL 50 / UL 50E	Type 12
With CKR 65	Type 4 / 4X
Ambient temperature limits	-40 °C ... +125 °C
Mechanical life (cycles)	≥ 500



(pending: CQC, DNV and BV)

(pending: cURus)

Item	Description	Part No.	Entry	Dimension
	Hoods, 1 galvanised steel rigid lever, top entry Not suitable for CQ4 series inserts	MKA VG20 CKA 03 VGS	M20 Pg 11	
	Hoods, 1 stainless steel rigid lever or 1 galvanised rigid lever, top entry	Stainless steel rigid lever MKAXX VG25	M25	
		Galvanised rigid lever MKA VG25	M25	

CKA / MKA

A

Compact 21.21 Inserts	Poles	Pages
CQ4 / CQ / CQY	40 A to 6,5 A	2 to 21 + ⊕
CK / JK / CKSH	10 A	3 to 4 + ⊕
CD / CDY	10 A	8
CJ (RJ45)	1 A to 2,1 A	–
CUK (USB)	–	–
CX (BUS)	10 A	–
CLK (Fibre optics)	–	–

Note: to obtain the IP66 / IP67 / IP69 degree of protection it is necessary to replace the fixing screw supplied with all inserts, with the one with gasket included in the CKR 65 kit, to be purchased separately, except for the inserts listed below (already supplied with a fixing screw with gasket):

- CQF/M 07, CQF/M 12
- CJ KF
- CJK 8FT /8IFT
- CUK 2FT /3FT
- CX 1/2 BDF/M
- CLK 04 SCF /SCF-H /SCM

Accessories:



CKR 65
gasket and screw kits for IP66 / IP67 / IP69
Page A.67

Metallic – CKA / MKA

Housings – 1 lever – fixing by 4 screws

size **21.21**Heavy-Duty
Applications

EN 60529	IP44
With CKR 65	IP66 / IP67 / IP69
UL 50 / UL 50E	Type 12
With CKR 65	Type 4 / 4X
Ambient temperature limits	-40 °C ... +125 °C
Mechanical life (cycles)	≥ 500

CE UK
CA

ECBT2.E115072 | ECBT8.E115072

Item	Description	Part No.	Entry	Dimension
	Angled bulkhead mounting housings, 1 stainless steel lever, fixing by 4 screws	CKAX 03 IA4		
	Angled surface mounting housings, 1 stainless steel lever, with cable entry, fixing by 4 screws, <u>open or closed bottom flange</u>	Open bottom flange MKAX IAP25	M25	
		Closed bottom flange MKAX AP25	M25	

Compact 21.21 Inserts	Poles	Pages
CQ4 / CQ / CQY	40 A to 6,5 A	2 to 21 + ☉
CK / JK / CKSH	10 A	3 to 4 + ☉
CD / CDY	10 A	8
CJ (RJ45)	1 A to 2,1 A	–
CUK (USB)	–	–
CLK (Fibre optics)	–	–

Note: to obtain the IP66 / IP67 / IP69 degree of protection it is necessary to replace the fixing screw supplied with all inserts, with the one with gasket included in the CKR 65 kit, to be purchased separately, except for the inserts listed below (already supplied with a fixing screw with gasket):

- CQF/M 07, CQF/M 12 - CUK 2FT /3FT
 - CJ KF - CLK 04 SCF /SCF-H /SCM
 - CJK 8FT /8IFT

Accessories:

CKR 65
 gasket and screw kits for
 IP66 / IP67 / IP69
 Page A.67



Metallic – CKA / MKA

size **21.21**

Housings – 1 lever – with fixing thread

Heavy-Duty Applications

EN 60529	IP44
With CKR 65	IP66 / IP67 / IP69
UL 50 / UL 50E	Type 12
With CKR 65	Type 4 / 4X
Ambient temperature limits	-40 °C ... +125 °C
Mechanical life (cycles)	≥ 500



RUUS ECBT2.E115072 | ECBT8.E115072

Item	Description	Part No.	Entry	Dimension
	Bulkhead mounting housings, 1 stainless steel lever, M32 fixing thread - Locknut supplied on request, see Cable glands catalogue (article AS M32N metallic)	With o-ring gasket MKAX IF	M32	
		With flange gasket and locknut MKAX IFC	M32	
	Bulkhead mounting housings, 1 stainless steel rigid lever or 1 galvanized rigid lever, M32 fixing thread, with o-ring gasket - Locknut supplied on request, see Cable glands catalogue (article AS M32N metallic) CQC, DNV, BV and cURus pending	Stainless steel rigid lever MKAXX IF	M32	
		Galvanized rigid lever MKA IF	M32	
	Bulkhead mounting housings, 1 stainless steel rigid lever or 1 galvanized rigid lever, M32 fixing thread, with flange gasket and locknut CQC, DNV, BV and cURus pending	Stainless steel rigid lever MKAXX IFC	M32	
		Galvanized rigid lever MKA IFC	M32	
	Angled bulkhead mounting housings, 1 stainless steel lever, fixing thread with O-ring gasket - Locknut supplied on request, see Cable glands catalogue (article AS M32N metallic) Not suitable for CQ4 series inserts	MKAX IAF20 MKAX IAF25	M20 M25	
	Angled bulkhead mounting housings, 1 galvanized rigid lever, fixing thread with O-ring gasket - Locknut supplied on request, see Cable glands catalogue (article AS M32N metallic) Not suitable for CQ4 series inserts CQC, DNV, BV and cURus pending	MKA IAF20 MKA IAF25	M20 M25	

Compact 21.21 Inserts	Poles	Pages
CQ4 / CQ / CQY	40 A to 6,5 A	2 to 21 + ⊕
CK / JK / CKSH	10 A	3 to 4 + ⊕
CD / CDY	10 A	8
CJ (RJ45)	1 A to 2,1 A	-
CUK (USB)	-	-
CX (BUS)	10 A	-
CLK (Fibre optics)	-	4

Note: to obtain the IP66 / IP67 / IP69 degree of protection it is necessary to replace the fixing screw supplied with all inserts, with the one with gasket included in the CKR 65 kit, to be purchased separately, except for the inserts listed below (already supplied with a fixing screw with gasket):

- CQF/M 07, CQF/M 12
- CJ KF
- CJK 8FT /8IFT
- CUK 2FT /3FT
- CX 1/2 BDF/M
- CLK 04 SCF /SCF-H /SCM

Accessories:



CKR 65
gasket and screw kits for IP66 / IP67 / IP69
Page A.67

Metallic – CKA / MKA


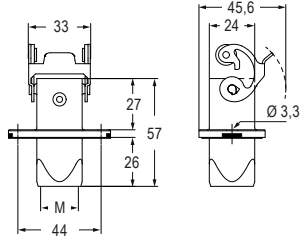

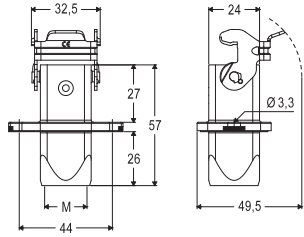

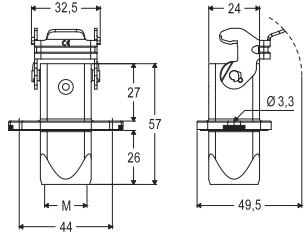
Housings – 1 lever – with rear cable entry

size **21.21**
**Heavy-Duty
Applications**


EN 60529	IP44
With CKR 65	IP66 / IP67 / IP69
UL 50 / UL 50E	Type 12
With CKR 65	Type 4 / 4X
Ambient temperature limits	-40 °C ... +125 °C
Mechanical life (cycles)	≥ 500

CE UK

RUUS ECBT2.E115072 | ECBT8.E115072

Item	Description	Part No.	Entry	Dimension
	Bulkhead mounting housings, 1 stainless steel lever, M20 rear cable entry	MKAX IVG20	M20	
	Bulkhead mounting housings, 1 stainless steel rigid lever, M20 rear cable entry CQC, DNV, BV and cURus pending	MKAXX IVG20	M20	
	Bulkhead mounting housings, 1 galvanized rigid lever, M20 rear cable entry CQC, DNV, BV and cURus pending	MKA IVG20	M20	

Compact 21.21 Inserts	Poles	Pages
CQ4 / CQ / CQY	40 A to 6,5 A	2 to 21 + ☉
CK / JK / CKSH	10 A	3 to 4 + ☉
CD / CDY	10 A	8
CJ (RJ45)	1 A to 2,1 A	–
CUK (USB)	–	–
CLK (Fibre optics)	–	–

Note: to obtain the IP66 / IP67 / IP69 degree of protection it is necessary to replace the fixing screw supplied with all inserts, with the one with gasket included in the CKR 65 kit, to be purchased separately, except for the inserts listed below (already supplied with a fixing screw with gasket):

- CQF/M 07, CQF/M 12 - CUK 2FT /3FT
- CJ KF - CLK 04 SCF /SCF-H /SCM
- CJK 8FT /8IFT

Accessories:


CKR 65
gasket and screw kits for
IP66 / IP67 / IP69
Page A.67



Metallic – CKA / MKA

size **21.21**

Housings – 1 lever – fixing by 4 screws

Heavy-Duty Applications

EN 60529	IP44
With CKR 65	IP66 / IP67 / IP69
UL 50 / UL 50E	Type 12
With CKR 65	Type 4 / 4X
Ambient temperature limits	-40 °C ... +125 °C
Mechanical life (cycles)	≥ 500



(pending: CQC, DNV and BV)

(pending: cURus)

Item	Description	Part No.	Entry	Dimension
	Angled bulkhead mounting housings, 1 stainless steel rigid lever or 1 galvanized rigid lever, fixing by 4 screws	Stainless steel rigid lever CKAXX 03 IA4		
		Galvanized rigid lever CKA 03 IA4		
	Angled surface mounting housings, 1 stainless steel rigid lever or 1 galvanized rigid lever, with cable entry, fixing by 4 screws, with <u>open bottom flange</u>	Stainless steel rigid lever MKAXX IAP25	M25	
		Galvanized rigid lever MKA IAP25	M25	
	Angled surface mounting housings, 1 stainless steel rigid lever or 1 galvanized rigid lever, with cable entry, fixing by 4 screws, with <u>closed bottom flange</u>	Stainless steel rigid lever MKAXX AP25	M25	
		Galvanized rigid lever MKA AP25	M25	

CKA / MKA

A

Compact 21.21 Inserts	Poles	Pages
CQ4 / CQ / CQY	40 A to 6,5 A	2 to 21 + ☺
CK / JK / CKSH	10 A	3 to 4 + ☺
CD / CDY	10 A	8
CJ (RJ45)	1 A to 2,1 A	–
CUK (USB)	–	–
CLK (Fibre optics)	–	–

Note: to obtain the IP66 / IP67 / IP69 degree of protection it is necessary to replace the fixing screw supplied with all inserts, with the one with gasket included in the CKR 65 kit, to be purchased separately, except for the inserts listed below (already supplied with a fixing screw with gasket):

- CQF/M 07, CQF/M 12
- CJ KF
- CJK 8FT /8IFT
- CUK 2FT /3FT
- CLK 04 SCF /SCF-H /SCM

Accessories:



CKR 65
gasket and screw kits for IP66 / IP67 / IP69
Page A.67

Metallic – CKA / MKA


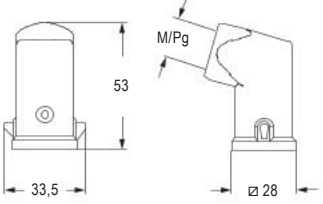

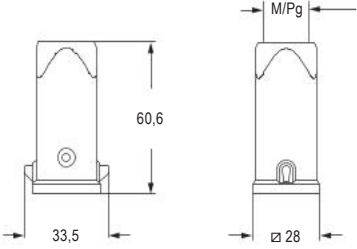

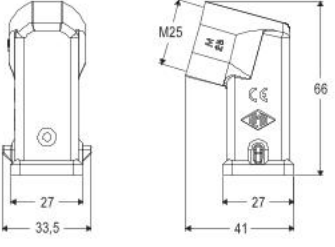

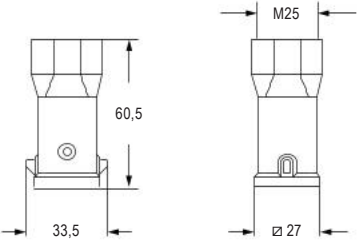


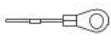
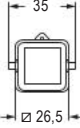

Hoods and covers – 2 pegs

size **21.21**
**Heavy-Duty
Applications**


EN 60529	IP44
With CKR 65	IP66 / IP67 / IP69
UL 50 / UL 50E	Type 12
With CKR 65	Type 4 / 4X
Ambient temperature limits	-40 °C ... +125 °C
Mechanical life (cycles)	≥ 500

CE UK

CAIUS ECBT2.E115072 | ECBT8.E115072

Item	Description	Part No.	Entry	Dimension
	Hoods, 2 pegs, side entry Not suitable for CQ4 series inserts	MKA VA20 CKA 03 VAS	M20 Pg 11	
	Hoods, 2 pegs, top entry Not suitable for CQ4 series inserts	MKA V20 CKA 03 VS	M20 Pg 11	
	Hoods, 2 pegs, side entry	MKA VA25	M25	
	Hoods, 2 pegs, top entry	MKA V25	M25	
	Covers, 2 pegs, with or without gasket For enclosures with 1 lever with loop for hoods  or with eyelet for housings 	With loop With gasket (for female inserts) CKA 03 CS Without gasket (for male inserts) CKA 03 CAS	With eyelet CKA 03 C CKA 03 CA	 

Compact 21.21 Inserts	Poles	Pages
CQ4 / CQ / CQY	40 A to 6,5 A	A.4-12
CK / JK / CKSH	10 A	A.16-19
CD / CDY	10 A	A.24-25

Note: to obtain the IP66 / IP67 / IP69 degree of protection it is necessary to replace the fixing screw supplied with all inserts, with the one with gasket included in the CKR 65 kit, to be purchased separately, except for the inserts listed below (already supplied with a fixing screw with gasket):

- CQF/M 07, CQF/M 12

Accessories:


CKR 65
gasket and screw kits for
IP66 / IP67 / IP69
Page [A.67](#)



Metallic – CKA / MKA – DESINA®

size **21.21**

Housings – 1 lever

Heavy-Duty Applications

EN 60529	IP44
With CKR 65	IP66 / IP67 / IP69
UL 50 / UL 50E	Type 12
With CKR 65	Type 4 / 4X
Ambient temperature limits	-40 °C ... +125 °C
Mechanical life (cycles)	≥ 500



RUUS ECBT2.E115072 | ECBT8.E115072

Item	Description	Part No.	With cover	Dimension
	Bulkhead mounting housings, 1 stainless steel lever, with or without self-closing cover DESINA® version - cover with glued gasket	CKAX 03 I	CKAX 03 ILS	
	Bulkhead mounting housings, 1 galvanized steel rigid lever, with or without self-closing cover DESINA® version - cover with glued gasket CQC, DNV, BV and cURus pending	CKA 03 I	CKA 03 ILS	

CKA / MKA – DESINA®

A

Compact 21.21 Inserts	Poles	Pages
CQ4 / CQ / CQY	40 A to 6,5 A	2 to 21 + ☉
CK / JK / CKSH	10 A	3 to 4 + ☉
CD / CDY	10 A	8
CJ (RJ45)	1 A to 2,1 A	–
CUK (USB)	–	–
CX (BUS)	10 A	–
CLK (Fibre optics)	–	4

DESINA® version: suitable for DESINA® CJ, CUK, CLK, CX BD adapters for male inserts without gasket

Metallic – CKA / MKA – DESINA®

size **21.21**

Hoods and covers – 2 pegs

**Heavy-Duty
Applications**


EN 60529	IP44
With CKR 65	IP66 / IP67 / IP69
UL 50 / UL 50E	Type 12
With CKR 65	Type 4 / 4X
Ambient temperature limits	-40 °C ... +125 °C
Mechanical life (cycles)	≥ 500

CE UK

CAIUS ECBT2.E115072 | ECBT8.E115072

Item	Description	Part No.	Entry	Dimension
	Hoods, 2 pegs and glued gasket, side entry DESINA® version	MKAG VA20 CKAG 03 VA	M20 Pg 11	
	Hoods, 2 pegs and glued gasket, top entry DESINA® version	MKAG V20 CKAG 03 V	M20 Pg 11	
	Hoods, 2 pegs and glued gasket, side entry DESINA® version	MKAG VA25	M25	
	Hoods, 2 pegs and glued gasket, top entry DESINA® version	MKAG V25	M25	
	Covers, 2 pegs and glued gasket DESINA® version For hoods with 1 lever with eyelet 	CKAG 03 C		

Compact 21.21 Inserts	Poles	Pages
CJ (RJ45)	1 A to 2,1 A	A.30-33
CUK (USB)	-	A.36
CX (BUS)	10 A	A.37
CLK (Fibre optics)	4	A.38

DESINA® version: suitable for DESINA® CJ, CUK, CLK, CX BD adapters for male inserts without gasket

21.21 Enclosures

size **21.21**


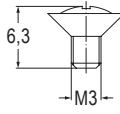
Accessories

Heavy-Duty Applications

CE UK CA



RUUS ECBT2.E115072 | ECBT8.E115072

Item	Description	Part No.	Dimension
	<p>Gasket and screw kits for IP66 / IP67 / IP69</p> <p>To obtain the IP66 / IP67 / IP69 degree of protection it is necessary to replace the fixing screw supplied with all inserts, with the one with gasket included in the CKR 65 kit, to be purchased separately, except for the inserts listed below (already supplied with a fixing screw with gasket):</p> <ul style="list-style-type: none"> - CQF/M 07, CQF/M 12 - CJ KF - CJK 8FT /8IFT - CUK 2FT /3FT - CX 1/2 BDF/M - CLK 04 SCF /SCF-H /SCM 	CKR 65	

	<p>Fixing frame, for size 21.21 complete free connector coupling</p> <p>Supplied with 2 × black cable ties</p> <p>CQC, DNV, BV and cURus pending</p>	CR CKT	
---	--	------------------------	---



Watch our clip

Materials	
Fixing frame	polycarbonate (PC)
UL 94 flame rating	V-0
Colour	black, RAL 9005


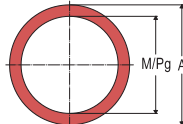

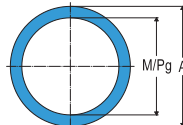

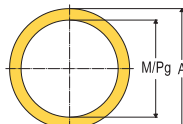

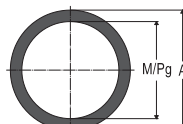
21.21 Enclosures

size 21.21

Accessories

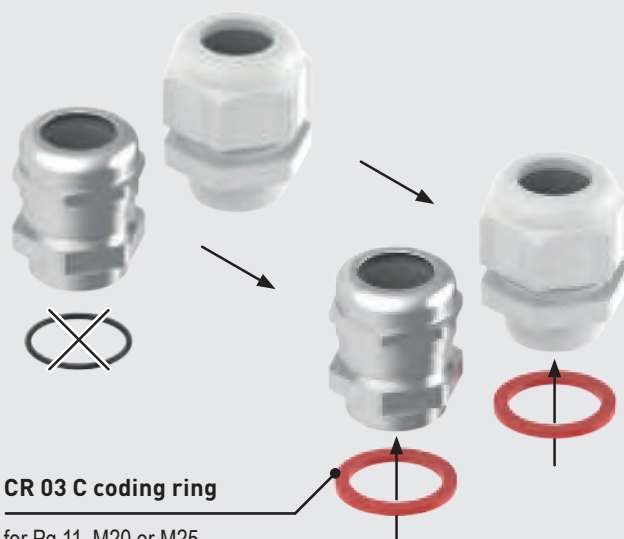
Heavy-Duty
Applications

EN 60529 IP66 / IP67 / IP69
Ambient temperature limits -25 °C ... +100 °C

Item	Description	Part No.	Entry	Dimension													
	Red coding ring for Pg 11, M20 or M25 threaded thermoplastic and metal cable glands	CR 03 C11R CR 03 C20R CR 03 C25R	Pg 11 M20 M25		<table border="1"> <thead> <tr> <th>Part No.</th> <th>Cable Entry</th> <th>A (mm)</th> </tr> </thead> <tbody> <tr> <td>CR 03 C11R</td> <td>Pg 11</td> <td>23</td> </tr> <tr> <td>CR 03 C20R</td> <td>M20</td> <td>24</td> </tr> <tr> <td>CR 03 C25R</td> <td>M25</td> <td>30</td> </tr> </tbody> </table>	Part No.	Cable Entry	A (mm)	CR 03 C11R	Pg 11	23	CR 03 C20R	M20	24	CR 03 C25R	M25	30
Part No.	Cable Entry	A (mm)															
CR 03 C11R	Pg 11	23															
CR 03 C20R	M20	24															
CR 03 C25R	M25	30															
	Blue coding ring for Pg 11, M20 or M25 threaded thermoplastic and metal cable glands	CR 03 C11B CR 03 C20B CR 03 C25B	Pg 11 M20 M25		<table border="1"> <thead> <tr> <th>Part No.</th> <th>Cable Entry</th> <th>A (mm)</th> </tr> </thead> <tbody> <tr> <td>CR 03 C11B</td> <td>Pg 11</td> <td>23</td> </tr> <tr> <td>CR 03 C20B</td> <td>M20</td> <td>24</td> </tr> <tr> <td>CR 03 C25B</td> <td>M25</td> <td>30</td> </tr> </tbody> </table>	Part No.	Cable Entry	A (mm)	CR 03 C11B	Pg 11	23	CR 03 C20B	M20	24	CR 03 C25B	M25	30
Part No.	Cable Entry	A (mm)															
CR 03 C11B	Pg 11	23															
CR 03 C20B	M20	24															
CR 03 C25B	M25	30															
	Yellow coding ring for Pg 11, M20 or M25 threaded thermoplastic and metal cable glands	CR 03 C11G CR 03 C20G CR 03 C25G	Pg 11 M20 M25		<table border="1"> <thead> <tr> <th>Part No.</th> <th>Cable Entry</th> <th>A (mm)</th> </tr> </thead> <tbody> <tr> <td>CR 03 C11G</td> <td>Pg 11</td> <td>23</td> </tr> <tr> <td>CR 03 C20G</td> <td>M20</td> <td>24</td> </tr> <tr> <td>CR 03 C25G</td> <td>M25</td> <td>30</td> </tr> </tbody> </table>	Part No.	Cable Entry	A (mm)	CR 03 C11G	Pg 11	23	CR 03 C20G	M20	24	CR 03 C25G	M25	30
Part No.	Cable Entry	A (mm)															
CR 03 C11G	Pg 11	23															
CR 03 C20G	M20	24															
CR 03 C25G	M25	30															
	Black coding ring for Pg 11, M20 or M25 threaded thermoplastic and metal cable glands	CR 03 C11N CR 03 C20N CR 03 C25N	Pg 11 M20 M25		<table border="1"> <thead> <tr> <th>Part No.</th> <th>Cable Entry</th> <th>A (mm)</th> </tr> </thead> <tbody> <tr> <td>CR 03 C11N</td> <td>Pg 11</td> <td>23</td> </tr> <tr> <td>CR 03 C20N</td> <td>M20</td> <td>24</td> </tr> <tr> <td>CR 03 C25N</td> <td>M25</td> <td>30</td> </tr> </tbody> </table>	Part No.	Cable Entry	A (mm)	CR 03 C11N	Pg 11	23	CR 03 C20N	M20	24	CR 03 C25N	M25	30
Part No.	Cable Entry	A (mm)															
CR 03 C11N	Pg 11	23															
CR 03 C20N	M20	24															
CR 03 C25N	M25	30															

FOCUS

Coding ring assembly



CR 03 C coding ring

for Pg 11, M20 or M25 threaded thermoplastic and metal cable glands

21.21 Enclosures


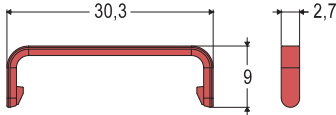

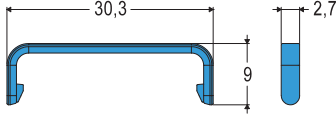

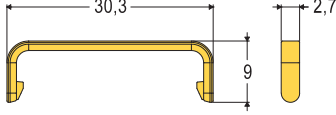

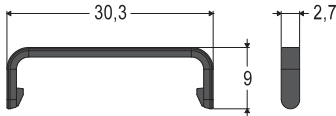
size **21.21**

Accessories

Heavy-Duty Applications



EN 60529	IP66 / IP67 / IP69
Ambient temperature limits	-25 °C ... +100 °C

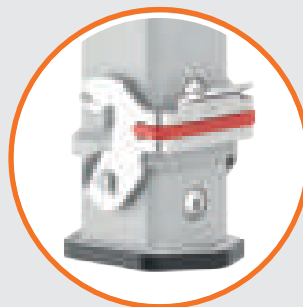
Item	Description	Part No.	Dimension
	Red thermoplastic coding clip for rigid galvanized steel / rigid stainless steel levers and thermoplastic levers	CR 03 CKR	
	Blue thermoplastic coding clip for rigid galvanized steel / rigid stainless steel levers and thermoplastic levers	CR 03 CKB	
	Yellow thermoplastic coding clip for rigid galvanized steel / rigid stainless steel levers and thermoplastic levers	CR 03 CKG	
	Black thermoplastic coding clip for rigid galvanized steel / rigid stainless steel levers and thermoplastic levers	CR 03 CKN	

ACCESSORIES

A

FOCUS

Coding clip assembly





Enclosures size 21.21 for aggressive and high demanding environments



The enclosures series presented in the following pages have been developed for application environments with particularly aggressive external agents or harsh operating conditions.

The black and dark grey colour of the coating distinguishes these hoods and housings serving outside from the ordinary heavy-duty industrial field: humid areas, chemicals and corrosive agents.

Each series can accommodate all 21.21 size connector inserts with either crimp, screw, **SQUICH®** or the innovative **AXYR®** termination technology, guaranteeing up to IP66 / IP67 / IP69 degree of protection (with CKR 65 screw-gasket kit – IP68 only for CGK / MGK series).

W-TYPE series

The W-TYPE enclosure series includes bulkhead mounting, surface mounting or hood type with side or top entry. Designed with a stainless steel monoblock locking lever, it features the following characteristics.

- > RAL 9005 jet black thermosetting epoxy powder coating with improved impact and corrosion resistance.
- > Nano-technological surface passivation to obtain maximum paint adhesion and chemical strength.
- > FKM fluoroelastomer gaskets (with improved resistance to chemicals and ageing).
- > Up to 500 hrs corrosion resistance (EN ISO 9227 - Salt Spray Tests).
- ✓ **Type 12; Type 4 and 4X using the optional special fixing screw + gasket kit CKR 65 (enclosure type ratings equivalent to the NEMA 250 ones).**
- ✓ **IP44 degree of protection, IP66 / IP67 / IP69 by using the special fixing screw + gasket kit CKR 65 separately available, and suitable cable outlet device.**

IP68 series

The IP68 enclosure series is particularly suitable for applications in the railway industry and everywhere it is required a high resistance to pressure, impact, and corrosion, with an IP66 / IP68 / IP69 protection rating.

- > Zinc-nickel coating with black passivation to increase the corrosion resistance of the enclosures.
- > NBR O-ring seal placed in a protected slot within each housing protected from the external environment for reduced wearing when the connector is locked.
- > M4 screw locking system with spring washers, maintaining the clamping force under vibration.
- > Up to 500 hrs corrosion resistance (EN ISO 9227 - Salt Spray Tests).
- > High mechanical stability and enhanced immunity to electromagnetic (EMC).

- ✔ **The IP68 degree of protection ensured by the enclosures is fully described in the IEC 60529 standard, which classifies the enclosures according to their protection against the entry of foreign bodies and water. IP68 = Total protection against dust, and against the access to hazardous parts with access probe of Ø 1,0 mm (1st characteristic numeral), and protection against the effects of continuous submersion in water (duration ≥ 30 min upon agreement and water depth ≥ 1 m upon agreement) (2nd characteristic numeral).**

E-Xtreme® series

- > The E-Xtreme® coating is the proprietary ILME solution for connectors installed in highly demanding environments, reducing the risk of connection failure and ensuring longer maintenance intervals on the enclosures.
- > The unique protective titanium treatment applied to the hoods and housings surfaces ensures maximum protection even in long-term exposure to corrosive agents. The E-Xtreme® series 21.21 size is available for a comprehensive selection of the standard enclosure variants, aluminium die-cast only.

TECHNICAL FEATURES

- > Aluminium die-cast enclosures with titanium coating
- > RAL 7016 dark grey thermosetting epoxy powder coating
- > FKM fluoroelastomer gaskets
- > Stainless steel locking lever

PERFORMANCE

- > 2 000 hrs corrosion resistance (EN ISO 9227 - Salt Spray Tests)
- > Improved compatibility with chemicals and mineral and synthetic oils
- ✔ **IP66 / IP67 / IP68 degree of protection and water. IP68 = Total protection against dust, and against the access to hazardous parts with access probe of Ø 1,0 mm (1st characteristic numeral), and protection against the effects of continuous submersion in water (duration ≥ 30 min upon agreement and water depth ≥ 1 m upon agreement) (2nd characteristic numeral).**

W-TYPE – CKAW / MKAW

size **21.21**


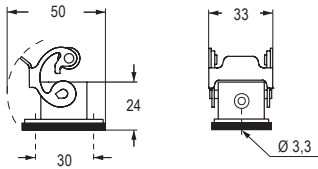

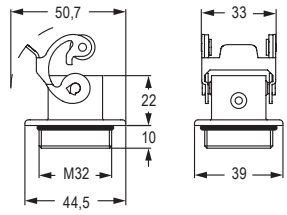

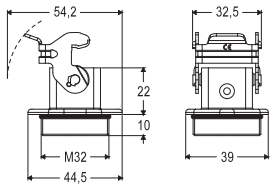

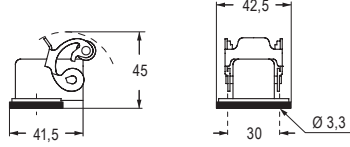

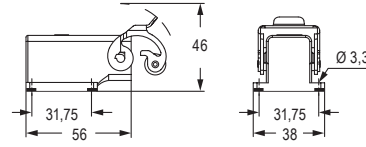
Housings – 1 lever

**Aggressive
Environments**


EN 60529	IP44
With CKR 65	IP66 / IP67 / IP69
UL 50 / UL 50E	Type 12
With CKR 65	Type 4 / 4X
Ambient temperature limits	-40 °C ... +125 °C
Mechanical life (cycles)	≥ 500

CE UK CA


CALUS ECBT2.E115072 | ECBT8.E115072

Item	Description	Part No.	Entry	Dimension
	Bulkhead mounting housings, 1 stainless steel lever	CKAXW 03 I		
	Bulkhead mounting housings, 1 stainless steel lever, M32 fixing thread - Locknut supplied on request, see Cable glands catalogue (article AS M32N metallic)	MKAXW IE	M32	
	Bulkhead mounting housings, 1 stainless steel rigid lever, M32 fixing thread - Locknut supplied on request, see Cable glands catalogue (article AS M32N metallic) CQC, DNV, BV and cURus pending	MKAXXW IE	M32	
	Angled bulkhead mounting housings, 1 stainless steel lever Not suitable for CQ4 series inserts	CKAXW 03 IA		
	Angled bulkhead mounting housings, 1 stainless steel lever, fixing by 4 screws	CKAXW 03 IA4		

Compact 21.21 Inserts	Poles	Pages
CQ4 / CQ / CQY	40 A to 6,5 A	A.4-12
CK / JK / CKSH	10 A	A.16-19
CD / CDY	10 A	A.24-25

Note: to obtain the IP66 / IP67 / IP69 degree of protection it is necessary to replace the fixing screw supplied with all inserts, with the one with gasket included in the CKR 65 kit, to be purchased separately, except for the inserts listed below (already supplied with a fixing screw with gasket):

- CQF/M 07, CQF/M 12

Accessories:


CKR 65
gasket and screw kits for
IP66 / IP67 / IP69
Page [A.67](#)



W-TYPE – CKAW / MKAW

size **21.21**

Housings – 1 lever

Aggressive Environments

EN 60529	IP44
With CKR 65	IP66 / IP67 / IP69
UL 50 / UL 50E	Type 12
With CKR 65	Type 4 / 4X
Ambient temperature limits	-40 °C ... +125 °C
Mechanical life (cycles)	≥ 500



RUUS ECBT2.E115072 | ECBT8.E115072

Item	Description	Part No.	Entry	Dimension
	Angled bulkhead mounting housings, 1 stainless steel rigid lever, fixing by 4 screws CQC, DNV, BV and cURus pending	CKAXXW 03IA4		
	Angled bulkhead mounting housings, 1 stainless steel lever, with cable entry, open or closed bottom flange Not suitable for CQ4 series inserts	Open bottom flange MKAXW IAP20 CKAXW 03 IAP	M20 Pg 11	
		Closed bottom flange MKAXW AP20 CKAXW 03 AP	M20 Pg 11	
	Angled surface mounting housings, 1 stainless steel lever, with cable entry, fixing by 4 screws, open or closed bottom flange	Open bottom flange MKAXW IAP25	M25	
		Closed bottom flange MKAXW AP25	M25	
	Angled surface mounting housings, 1 stainless steel rigid lever, with cable entry, fixing by 4 screws, open or closed bottom flange CQC, DNV, BV and cURus pending	Open bottom flange MKAXXW IAP25	M25	
		Closed bottom flange MKAXXW AP25	M25	

CKAW / MKAW

A

Compact 21.21 Inserts	Poles	Pages
CQ4 / CQ / CQY	40 A to 6,5 A	2 to 21 + ⊕
CK / JK / CKSH	10 A	3 to 4 + ⊕
CD / CDY	10 A	8

Note: to obtain the IP66 / IP67 / IP69 degree of protection it is necessary to replace the fixing screw supplied with all inserts, with the one with gasket included in the CKR 65 kit, to be purchased separately, except for the inserts listed below (already supplied with a fixing screw with gasket):

- CQF/M 07, CQF/M 12

Accessories:



CKR 65
gasket and screw kits for
IP66 / IP67 / IP69
Page A.67

W-TYPE – CKAW / MKAW

Hoods – 1 lever

size **21.21**
**Aggressive
Environments**


EN 60529	IP44
With CKR 65	IP66 / IP67 / IP69
UL 50 / UL 50E	Type 12
With CKR 65	Type 4 / 4X
Ambient temperature limits	-40 °C ... +125 °C
Mechanical life (cycles)	≥ 500

**CE UK
CA**

CALUS ECBT2.E115072 | ECBT8.E115072

Item	Description	Part No.	Entry	Dimension
	Hoods, 1 galvanized steel lever, top entry Not suitable for CQ4 series inserts	MKAXW VG20 CKAXW 03 VG	M20 Pg 11	
	Hoods, 1 stainless steel lever, top entry	MKAXW VG25	M25	
	Hoods, 1 stainless steel rigid lever, top entry CQC, DNV, BV and cURus pending	MKAXXW VG25	M25	

Compact 21.21 Inserts	Poles	Pages
CQ4 / CQ / CQY	40 A to 6,5 A	2 to 21 + ⊕
CK / JK / CKSH	10 A	3 to 4 + ⊕
CD / CDY	10 A	8

Note: to obtain the IP66 / IP67 / IP69 degree of protection it is necessary to replace the fixing screw supplied with all inserts, with the one with gasket included in the CKR 65 kit, to be purchased separately, except for the inserts listed below (already supplied with a fixing screw with gasket):

- CQF/M 07, CQF/M 12

Accessories:


CKR 65
gasket and screw kits for
IP66 / IP67 / IP69
Page A.67



W-TYPE – CKAW / MKAW

size **21.21**

Hoods – 2 pegs

Aggressive Environments

EN 60529	IP44
With CKR 65	IP66 / IP67 / IP69
UL 50 / UL 50E	Type 12
With CKR 65	Type 4 / 4X
Ambient temperature limits	-40 °C ... +125 °C
Mechanical life (cycles)	≥ 500



RUUS ECBT2.E115072 | ECBT8.E115072

Item	Description	Part No.	Entry	Dimension
	Hoods, 2 pegs, side entry Not suitable for CQ4 series inserts	MKAW VA20 CKAW 03 VA	M20 Pg 11	
	Hoods, 2 pegs, top entry Not suitable for CQ4 series inserts	MKAW V20 CKAW 03 V	M20 Pg 11	
	Hoods, 2 pegs, side entry	MKAW VA25	M25	
	Hoods, 2 pegs, top entry	MKAW V25	M25	

CKAW / MKAW

A

Compact 21.21 Inserts	Poles	Pages
CQ4 / CQ / CQY	40 A to 6,5 A	2 to 21 + ⊕
CK / JK / CKSH	10 A	3 to 4 + ⊕
CD / CDY	10 A	8

Note: to obtain the IP66 / IP67 / IP69 degree of protection it is necessary to replace the fixing screw supplied with all inserts, with the one with gasket included in the CKR 65 kit, to be purchased separately, except for the inserts listed below (already supplied with a fixing screw with gasket):

- CQF/M 07, CQF/M 12

Accessories:



CKR 65
gasket and screw kits for
IP66 / IP67 / IP69
Page [A.67](#)

E-Xtreme® – CKAE / MKAE

size 21.21

Housings – 1 lever


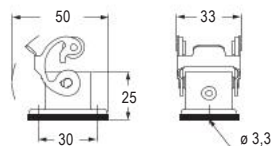

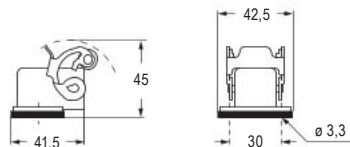


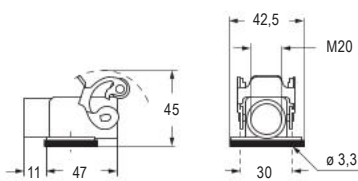

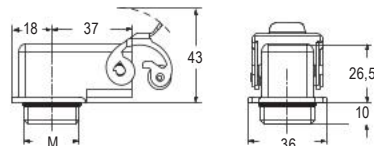

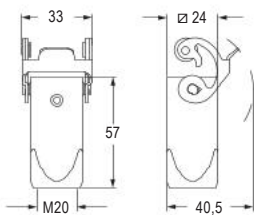
2 000 hrs resistance
in salt-spray testsAggressive
Environments

EN 60529	IP44
With CKR 65	IP66 / IP67 / IP69
UL 50 / UL 50E	Type 12
With CKR 65	Type 4 / 4X
Ambient temperature limits	-40 °C ... +125 °C
Mechanical life (cycles)	≥ 500

CE UK



CAIUS ECBT2.E115072 | ECBT8.E115072

Item	Description	Part No.	Entry	Dimension
	Bulkhead mounting housings, 1 stainless steel lever	CKAXE 03 I		
	Angled bulkhead mounting housings, 1 stainless steel lever Not suitable for CQ4 series inserts	CKAXE 03 IA		
 	Angled bulkhead mounting housings, 1 stainless steel lever, with cable entry, open or closed bottom flange Not suitable for CQ4 series inserts	Open bottom flange MKAXE IAP20 Closed bottom flange MKAXE AP20	M20 M20	
	Angled bulkhead mounting housings, 1 stainless steel lever, with fixing thread Not suitable for CQ4 series inserts	MKAXE IAF20 MKAXE IAF25	M20 M25	
	Hoods, 1 stainless steel lever, top entry Not suitable for CQ4 series inserts	MKAXE VG20	M20	

Compact 21.21 Inserts	Poles	Pages
CQ4 / CQ / CQY	40 A to 6,5 A	A.4-12
CK / JK / CKSH	10 A	A.16-19
CD / CDY	10 A	A.24-25

Note: to obtain the IP66 / IP67 / IP69 degree of protection it is necessary to replace the fixing screw supplied with all inserts, with the one with gasket included in the CKR 65 kit, to be purchased separately, except for the inserts listed below (already supplied with a fixing screw with gasket):

- CQF/M 07, CQF/M 12

Accessories:



CKR 65
gasket and screw kits for
IP66 / IP67 / IP69
Page [A.67](#)



E-Xtreme® – CKAE / MKAE

size **21.21**

Hoods – 2 pegs

2 000 hrs resistance
in salt-spray tests




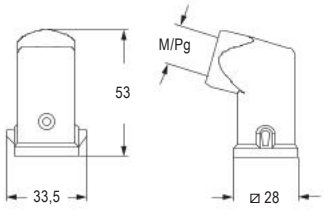

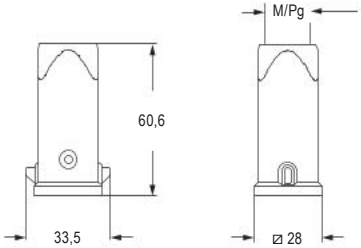
Aggressive
Environments



EN 60529	IP44
With CKR 65	IP66 / IP67 / IP69
UL 50 / UL 50E	Type 12
With CKR 65	Type 4 / 4X
Ambient temperature limits	-40 °C ... +125 °C
Mechanical life (cycles)	≥ 500



ECBT2.E115072 | ECBT8.E115072

Item	Description	Part No.	Entry	Dimension
	Hoods, 2 pegs, side entry Not suitable for CQ4 series inserts	MKAE VA20	M20	
	Hoods, 2 pegs, top entry Not suitable for CQ4 series inserts	MKAE V20	M20	

CKAE / MKAE

A

Compact 21.21 Inserts	Poles	Pages
CQ4 / CQ / CQY	40 A to 6,5 A	A.4-12
CK / JK / CKSH	10 A	A.16-19
CD / CDY	10 A	A.24-25

Note: to obtain the IP66 / IP67 / IP69 degree of protection it is necessary to replace the fixing screw supplied with all inserts, with the one with gasket included in the CKR 65 kit, to be purchased separately, except for the inserts listed below (already supplied with a fixing screw with gasket):

- CQF/M 07, CQF/M 12

Accessories:



CKR 65
gasket and screw kits for
IP66 / IP67 / IP69
Page [A.67](#)


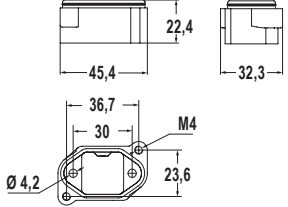

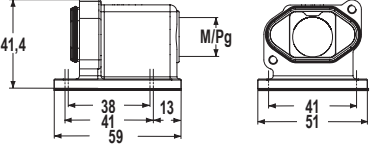

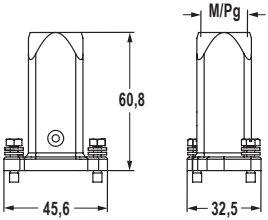

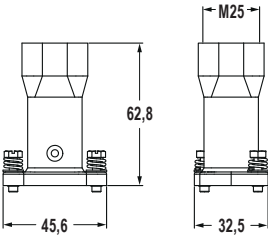
IP68 high protection – CGK / MGK

Housings and hoods – Screw locking

size **21.21**Aggressive
EnvironmentsCE UK
CA

EN 60529	IP66 / IP68 / IP69
UL 50 / UL 50E	Type 12 / 4 / 4X
Ambient temperature limits	-40 °C ... +125 °C
Mechanical life (cycles)	≥ 500

ECBT2.E115072 | ECBT8.E115072

Item	Description	Part No.	Entry	Dimension
	Bulkhead mounting housings, screw locking	CGK I		
	Angled bulkhead mounting housings, with cable entry, bottom closed, screw locking Without cable entry (on request)	MGK IAP20 CGK IAP13 CGK IA	M20 Pg 13,5	
	Hoods, top entry, screw locking Not suitable for CQ4 series inserts	MGK V20 CGK V13	M20 Pg 13,5	
	Hoods, top entry, screw locking	MGK V25	M25	

Compact 21.21 Inserts	Poles	Pages
CQ4 / CQ / CQY	40 A to 6,5 A	2 to 21 + ☉
CK / JK / CKSH	10 A	3 to 4 + ☉
CD / CDY	10 A	8
CJ (RJ45)	1 A to 2,1 A	–
CUK (USB)	–	–
CX (BUS)	10 A	–
CLK (Fibre optics)	–	–

Notes:

Eliminate the gasket and the fixing screw; provided with the insert. To fix the insert, use the screw with gasket provided with the enclosure.

Accessories:

CGKCP FX
Dust protection cover
Page G.47



CGKCP MB
Dust protection cover
Page G.47



IP68 high protection – CGK / MGK

size **21.21**

Housings and hoods – Bayonet locking


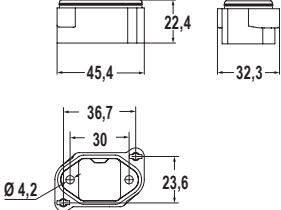

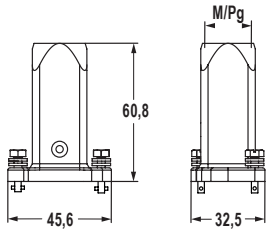

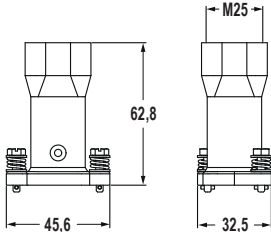
Aggressive Environments

CE UK

EN 60529	IP66 / IP68 / IP69
UL 50 / UL 50E	Type 12 / 4 / 4X
Ambient temperature limits	-40 °C ... +125 °C
Mechanical life (cycles)	≥ 500



US ECBT2.E115072 | ECBT8.E115072

Item	Description	Part No.	Entry	Dimension
	Bulkhead mounting housings, bayonet locking	CGK I B		
	Hoods, top entry, bayonet locking Not suitable for CQ4 series inserts	MGK V20 B CGK V13 B	M20 Pg 13,5	
	Hoods, top entry, bayonet locking	MGK V25 B	M25	

CGK / MGK

A

Compact 21.21 Inserts	Poles	Pages
CQ4 / CQ / CQY	40 A to 6,5 A	2 to 21 + ☉
CK / JK / CKSH	10 A	3 to 4 + ☉
CD / CDY	10 A	8
CJ (RJ45)	1 A to 2,1 A	–
CUK (USB)	–	–
CX (BUS)	10 A	–
CLK (Fibre optics)	–	–

Notes:
Eliminate the gasket and the fixing screw; provided with the insert. To fix the insert, use the screw with gasket provided with the enclosure.

Accessories:



CGKCP FX
Dust protection cover
Page G.47



CGKCP MB
Dust protection cover
Page G.47


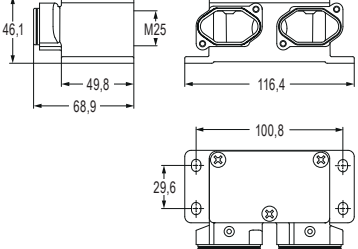
IP68 high protection – CGK / MGK


Special housings – Screw locking

size **21.21**Aggressive
EnvironmentsCE UK
CA

ECBT2.E115072 | ECBT8.E115072

EN 60529	IP66 / IP68 / IP69
UL 50 / UL 50E	Type 12 / 4 / 4X
Ambient temperature limits	-40 °C ... +125 °C
Mechanical life (cycles)	≥ 500

Item	Description	Part No.	Entry	Dimension
	Angled bulkhead mounting housings for two 21.21 sized connector inserts, with cable entry, bottom closed	MGK 2AP25	M25	
	CDF/M 07 series inserts (with pass-through protective earth contact) are suitable only by separate earthing of the housing through its internal PE terminal (CR MBT kit separately available)			
	to be employed: <ul style="list-style-type: none"> - for equipotential bonding connection between cover and housing PE terminals (2× required); - for PE connection of the housing (1× required) when used with CDF/M 07 inserts 			

	Internal PE terminal connection kit for MGK 2AP25	CR MBT		
	kit consists of: <ul style="list-style-type: none"> - Ø 4 mm eyelet crimp cable lug for 6 mm² max. PE wire, tin-plated brass; - M3,5×6 self-tapping screw with Ph 2 head, stainless steel with Ø 4 mm washer 			



Watch our clip

Compact 21.21 Inserts	Poles	Pages
CQ4 / CQ / CQY	40 A to 6,5 A	2 to 21 + ⊕
CK / JK / CKSH	10 A	3 to 4 + ⊕
CD / CDY	10 A	8
CJ (RJ45)	1 A to 2,1 A	–
CUK (USB)	–	–
CX (BUS)	10 A	–
CLK (Fibre optics)	–	4

Accessories:
CGKCP FX
 Dust protection
 cover
 Page G.47

IP68 high protection – CGK / MGK

size **21.21**

Covers – Screw and bayonet locking

Aggressive Environments


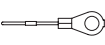
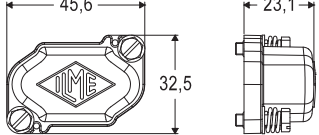

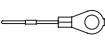
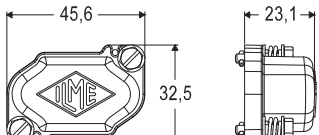

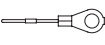
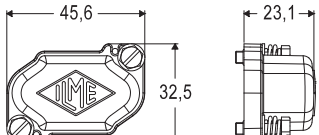


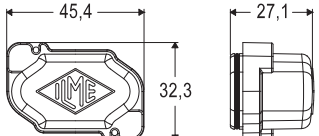


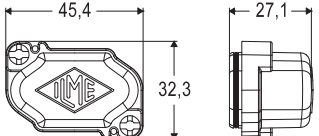


CE UK

(pending: CQC, DNV and BV)

(pending: cURus)

EN 60529	IP66 / IP68 / IP69
UL 50 / UL 50E	Type 12 / 4 / 4X
Ambient temperature limits	-40 °C ... +125 °C
Mechanical life (cycles)	≥ 500

Item	Description	Part No.	Dimension
	Covers for bulkhead mounting housings, screw locking with eyelet 	CGK C	
	Covers for bulkhead mounting housings, bayonet locking with eyelet 	CGK C B	
	Covers for MGK 2AP25 angled bulkhead mounting housings, screw locking with eyelet 	CGK C6	
	Covers for hoods, screw locking with loop 	CGK CG	
	Covers for hoods, bayonet locking with loop 	CGK CG B	

CGK / MGK

A

Enclosures size 21.21 for EMC applications



Electromagnetic compatibilities of electrical components are relevant factors for the engineer who deals with the final verification of an electronic device's compliance with Directive 2014/30/EU (electromagnetic compatibility).

Numerous products meet electromagnetic compatibility standards without the use of specific shielding.

However, industrial machinery and equipment with complex automation or high-frequency power supplies require explicit shielding from the possible noise source.

The ILME compact **EMC** enclosures size 21.21 offer the opportunity to use 40 A power inserts close to sensitive signals or data adapters, independently powered circuits that might be affected by mutual interaction or simply require to be isolated from the application environment.

Technical Features

The shielding capability of a connector is achieved primarily by providing a homogeneous and uniform electrical continuity between the enclosure components (hood and housing), cable shield and device body. ILME bulkhead mounting and surface mounting housings are supplied with conductive gaskets, guaranteeing optimal shielding and sealing performance (up to IP67).

- > Zinc-plated housings available in bulkhead mounting, surface mounting versions, with screws or locknut fixing.
- > Zinc-plated hoods with metric cable entries up to M25.
- > Stainless steel locking lever.
- > EMI / RFI Rubber - Conductive flange gasket material.
- > Optional EMI/RFI Rubber conductive insert gasket (CR 21.21 GMS).

IMPORTANT NOTE: For optimal shielding performance of the connectors, it is essential to improve the quality of the cables (which are mainly responsible for radiated interference) and use EMC cable glands, which dramatically increase the efficiency of shielding by creating a very homogeneous and continuous contact between the cable shield and connector enclosure.

Shielding attenuation of 21.21 enclosures

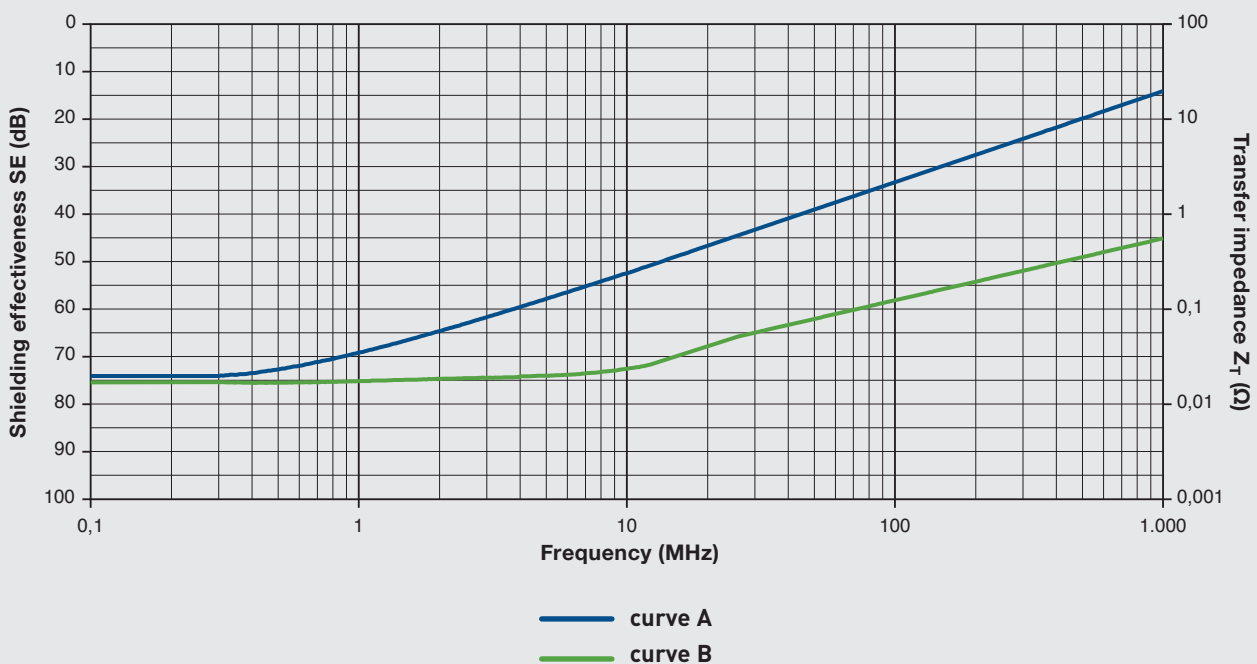
The diagram shows the shielding attenuation (measured in dB) as a function of frequency in MHz on the coupled enclosures as:

- > **curve A** ——— standard enclosures with standard cable gland and shielded cable wired to the earth terminal of the insert;
- > **curve B** ——— EMC enclosures with optional CR 21.21 GMS gasket, EMC cable gland and shielded cable wired to the cable gland. See diagram below.

The measurements suggest the following considerations:

- > standard enclosures already provide good levels of shielding attenuation;
- > EMC enclosures, with better shielding attenuation values, provide further improvements;
- > the optional CR 21.21 GMS conductive insert gasket further improve the shielding performance.

☑ **NOTE:** For the relationship between Shielding effectiveness SE and Transfer impedance (Ω) see also IEC 60512-23-3: $SE = 40 - 20\log_{10}Z_T$ (dB).



EMC series – Electromagnetic Shielding


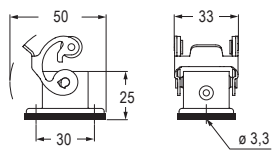

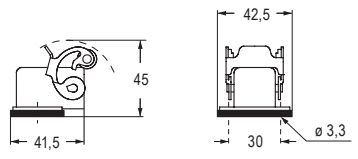


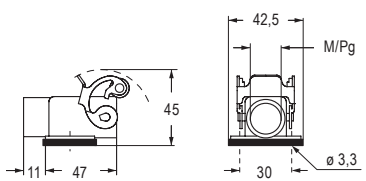
size **21.21**

Housings – 1 lever

Specialized
Applications

EN 60529	IP44
With CKR 65	IP66 / IP67 / IP69
UL 50 / UL 50E	Type 12
With CKR 65	Type 4 / 4X
Ambient temperature limits	-40 °C ... +125 °C
Mechanical life (cycles)	≥ 500

CE UK
CAC[®] A[®] US ECBT2.E115072 | ECBT8.E115072

Item	Description	Part No.	Entry	Dimension
	Bulkhead mounting housings, 1 stainless steel lever	CKAXS 03 I		
	Angled bulkhead mounting housings, 1 stainless steel lever Not suitable for CQ4 series inserts	CKAXS 03 IA		
 	Angled bulkhead mounting housings, 1 stainless steel lever, with cable entry, open or closed bottom flange Not suitable for CQ4 series inserts	Open bottom flange MKAXS IAP20 CKAXS 03 IAP Closed bottom flange MKAXS AP20 CKAXS 03 AP	M20 Pg 11 M20 Pg 11	

Compact 21.21 Inserts	Poles	Pages
CQ4 / CQ / CQY	40 A to 6,5 A	2 to 21 + ☉
CK / JK / CKSH	10 A	3 to 4 + ☉
CD / CDY	10 A	8

Note: to obtain the IP66 / IP67 / IP69 degree of protection it is necessary to replace the fixing screw supplied with all inserts, with the one with gasket included in the CKR 65 kit, to be purchased separately, except for the inserts listed below (already supplied with a fixing screw with gasket):

- CQF/M 07, CQF/M 12

Accessories:

CKR 65
gasket and screw kits for
IP66 / IP67 / IP69
Page A.67

EMC series – Electromagnetic Shielding

size **21.21**

Housings – 1 lever – fixing by 4 screws

Specialized Applications

EN 60529	IP44
With CKR 65	IP66 / IP67 / IP69
UL 50 / UL 50E	Type 12
With CKR 65	Type 4 / 4X
Ambient temperature limits	-40 °C ... +125 °C
Mechanical life (cycles)	≥ 500

CE UK



RUUS ECBT2.E115072 | ECBT8.E115072

Item	Description	Part No.	Entry	Dimension
	Angled bulkhead mounting housings, 1 stainless steel lever, fixing by 4 screws	CKAXS 03 IA4		
	Angled bulkhead mounting housings, 1 stainless steel rigid lever or 1 galvanized rigid lever, fixing by 4 screws CQC, DNV, BV and cURus pending	Stainless steel rigid lever CKAXXS 03IA4 Galvanized rigid lever CKAS 03 IA4		
	Angled surface mounting housings, 1 stainless steel lever, with cable entry, fixing by 4 screws, open or closed bottom flange	Open bottom flange MKAXS IAP25 Closed bottom flange MKAXS AP25	M25 M25	
	Angled surface mounting housings, 1 stainless steel rigid lever or 1 galvanized rigid lever, with cable entry, fixing by 4 screws, with open bottom flange CQC, DNV, BV and cURus pending	Stainless steel rigid lever MKAXXS IAP25 Galvanized rigid lever MKAS IAP25	M25 M25	
	Angled surface mounting housings, 1 stainless steel rigid lever or 1 galvanized rigid lever, with cable entry, with closed bottom flange CQC, DNV, BV and cURus pending	Stainless steel rigid lever MKAXXS AP25 Galvanized rigid lever MKAS AP25	M25 M25	

Compact 21.21 Inserts	Poles	Pages
CQ4 / CQ / CQY	40 A to 6,5 A	A.4-12
CK / JK / CKSH	10 A	A.16-19
CD / CDY	10 A	A.24-25

Note: to obtain the IP66 / IP67 / IP69 degree of protection it is necessary to replace the fixing screw supplied with all inserts, with the one with gasket included in the CKR 65 kit, to be purchased separately, except for the inserts listed below (already supplied with a fixing screw with gasket):

- CQF/M 07, CQF/M 12

Accessories:

CKR 65 gasket and screw kits for IP66 / IP67 / IP69
Page A.67

EMC series – Electromagnetic Shielding


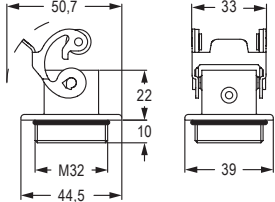

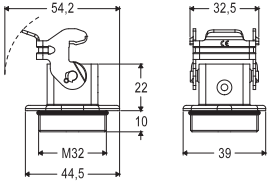

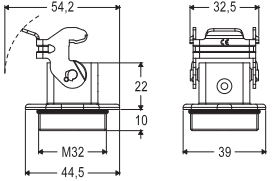
Housings – 1 lever – with fixing thread

size **21.21**Specialized
Applications

EN 60529	IP44
With CKR 65	IP66 / IP67 / IP69
UL 50 / UL 50E	Type 12
With CKR 65	Type 4 / 4X
Ambient temperature limits	-40 °C ... +125 °C
Mechanical life (cycles)	≥ 500

CE UK
CA

ECBT2.E115072 | ECBT8.E115072

Item	Description	Part No.	Entry	Dimension
	Bulkhead mounting housings, 1 stainless steel lever, M32 fixing thread - Locknut supplied on request, see Cable glands catalogue (article AS M32N metallic)	MKAXS IF	M32	
	Bulkhead mounting housings, 1 stainless steel rigid lever, M32 fixing thread - Locknut supplied on request, see Cable glands catalogue (article AS M32N metallic) CQC, DNV, BV and cURus pending	MKAXXS IF	M32	
	Bulkhead mounting housings, 1 galvanized rigid lever, M32 fixing thread - Locknut supplied on request, see Cable glands catalogue (article AS M32N metallic) CQC, DNV, BV and cURus pending	MKAS IF	M32	

Compact 21.21 Inserts	Poles	Pages
CQ4 / CQ / CQY	40 A to 6,5 A	2 to 21 + ☉
CK / JK / CKSH	10 A	3 to 4 + ☉
CD / CDY	10 A	8

Note: to obtain the IP66 / IP67 / IP69 degree of protection it is necessary to replace the fixing screw supplied with all inserts, with the one with gasket included in the CKR 65 kit, to be purchased separately, except for the inserts listed below (already supplied with a fixing screw with gasket):

- CQF/M 07, CQF/M 12

Accessories:



CKR 65
 gasket and screw kits for
 IP66 / IP67 / IP69
 Page A.67



EMC series – Electromagnetic Shielding

size **21.21**


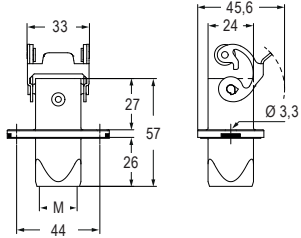

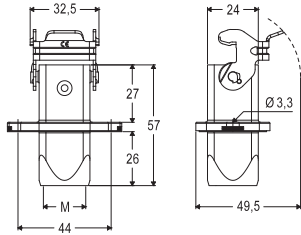

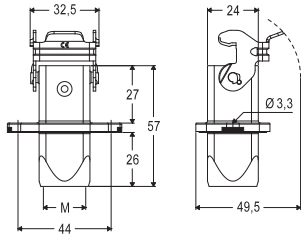
Housings – 1 lever – with rear cable entry

Specialized Applications

EN 60529	IP44
With CKR 65	IP66 / IP67 / IP69
UL 50 / UL 50E	Type 12
With CKR 65	Type 4 / 4X
Ambient temperature limits	-40 °C ... +125 °C
Mechanical life (cycles)	≥ 500



CALUS ECBT2.E115072 | ECBT8.E115072

Item	Description	Part No.	Entry	Dimension
	Bulkhead mounting housings, 1 stainless steel lever, M20 rear cable entry	MKAXS IVG20	M20	
	Bulkhead mounting housings, 1 stainless steel rigid lever, M20 rear cable entry CQC, DNV, BV and cURus pending	MKAXXS IVG20	M20	
	Bulkhead mounting housings, 1 galvanized rigid lever, M20 rear cable entry CQC, DNV, BV and cURus pending	MKAS IVG20	M20	

CKAS / MKAS

A



Watch our clip

Compact 21.21 Inserts	Poles	Pages
CQ4 / CQ / CQY	40 A to 6,5 A	2 to 21 + ☺
CK / JK / CKSH	10 A	3 to 4 + ☺
CD / CDY	10 A	8

Note: to obtain the IP66 / IP67 / IP69 degree of protection it is necessary to replace the fixing screw supplied with all inserts, with the one with gasket included in the CKR 65 kit, to be purchased separately, except for the inserts listed below (already supplied with a fixing screw with gasket):

- CQF/M 07, CQF/M 12

Accessories:



CKR 65
gasket and screw kits for
IP66 / IP67 / IP69
Page A.67

EMC series – Electromagnetic Shielding


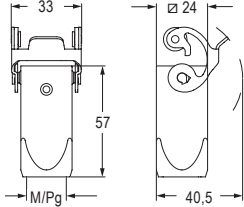

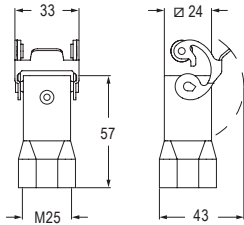

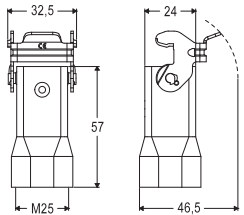

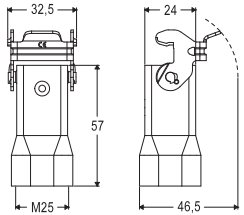
size **21.21**

Hoods – 1 lever

Specialized
Applications

EN 60529	IP44
With CKR 65	IP66 / IP67 / IP69
UL 50 / UL 50E	Type 12
With CKR 65	Type 4 / 4X
Ambient temperature limits	-40 °C ... +125 °C
Mechanical life (cycles)	≥ 500

CE UK
CAC[®]US ECBT2.E115072 | ECBT8.E115072

Item	Description	Part No.	Entry	Dimension
	Hoods, 1 stainless steel lever, top entry Not suitable for CQ4 series inserts	MKAXS VG20 CKAXS 03 VG	M20 Pg 11	
	Hoods, 1 stainless steel lever, top entry	MKAXS VG25	M25	
	Hoods, 1 stainless steel rigid lever, top entry CQC, DNV, BV and cURus pending	MKAXXS VG25	M25	
	Hoods, 1 galvanized rigid lever, top entry CQC, DNV, BV and cURus pending	MKAS VG25	M25	

Compact 21.21 Inserts	Poles	Pages
CQ4 / CQ / CQY	40 A to 6,5 A	2 to 21 + ⊕
CK / JK / CKSH	10 A	3 to 4 + ⊕
CD / CDY	10 A	8

Note: to obtain the IP66 / IP67 / IP69 degree of protection it is necessary to replace the fixing screw supplied with all inserts, with the one with gasket included in the CKR 65 kit, to be purchased separately, except for the inserts listed below (already supplied with a fixing screw with gasket):

- CQF/M 07, CQF/M 12

Accessories:

CKR 65
gasket and screw kits for
IP66 / IP67 / IP69
Page A.67



EMC series – Electromagnetic Shielding

size **21.21**

Hoods – 2 pegs

Specialized Applications

EN 60529	IP44
With CKR 65	IP66 / IP67 / IP69
UL 50 / UL 50E	Type 12
With CKR 65	Type 4 / 4X
Ambient temperature limits	-40 °C ... +125 °C
Mechanical life (cycles)	≥ 500



RUUS ECBT2.E115072 | ECBT8.E115072

Item	Description	Part No.	Entry	Dimension
	Hoods, 2 pegs, side entry Not suitable for CQ4 series inserts	MKAS VA20 CKAS 03 VA	M20 Pg 11	
	Hoods, 2 pegs, top entry Not suitable for CQ4 series inserts	MKAS V20 CKAS 03 V	M20 Pg 11	
	Hoods, 2 pegs, side entry	MKAS VA25	M25	
	Hoods, 2 pegs, top entry	MKAS V25	M25	

CKAS / MKAS

A

Compact 21.21 Inserts	Poles	Pages
CQ4 / CQ / CQY	40 A to 6,5 A	2 to 21 + ⊕
CK / JK / CKSH	10 A	3 to 4 + ⊕
CD / CDY	10 A	8

Note: to obtain the IP66 / IP67 / IP69 degree of protection it is necessary to replace the fixing screw supplied with all inserts, with the one with gasket included in the CKR 65 kit, to be purchased separately, except for the inserts listed below (already supplied with a fixing screw with gasket):

- CQF/M 07, CQF/M 12

Accessories:



CKR 65
gasket and screw kits for
IP66 / IP67 / IP69
Page [A.67](#)




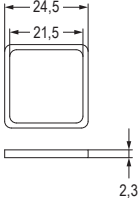

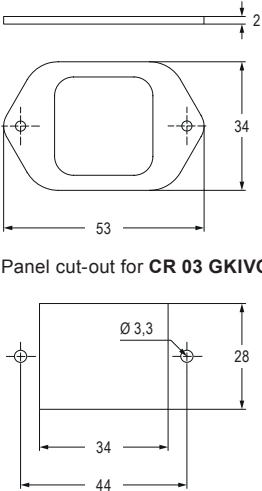
EMC series – Electromagnetic Shielding

size **21.21**

Accessories

Specialized
ApplicationsCE UK
CA

ECBT2.E115072 | ECBT8.E115072

Item	Description	Part No.	Dimension
	Gasket and screw kit:	CR 21.21 GMS	
	EMC gasket for male inserts 21.21 size		
	Flange gasket for MKAS IVG20 for reverse installation	CR 03 GKIVGR	 <p>Panel cut-out for CR 03 GKIVGR</p>
	The new CR 03 GKIVGR replacement rubber flange sealing gasket allows a 180° reversed installation of the special housings MKAS IVG20, so as to get the mating connector and the locking lever inside the cabinet and the M20 cable outlet outside the cabinet. This allows installation of preassembled connector wirings on a cabinet wall		

Materials

Gasket black, RAL 9005



A



Enclosures size 21.21 for HYGIENIC applications



The **CKH / MKH** HYGIENIC series complete the 21.21 size connectors product range by adding hoods and housings designed explicitly for hygienic, food & beverage applications (Splash Area - according to EN 1672-2).

Each component must endure contact with cleaning agents used in the food industry and must, therefore, be cleanable and resistant to the washing process without being the source of possible contaminants or retaining dirt.

The whole product family of compact 21.21 inserts for power, signal, and data connection can be safely used in food processing machinery and equipment, needing the distinct food industry's additional care and hygienic requirements.

Technical Features

The series offers the usual variants of the insulating 21.21 enclosures but in self-extinguishing dark grey RAL 7012 hygienic grade thermoplastic, compliant (together with the sealing gaskets material) with the EHEDG Guideline no. 32 and qualified for resistance to cleaning agents by ECOLAB.

Given their use with connector inserts often demanding larger wire size (power connector inserts) or larger wire bundle diameter (for high pole-number signal inserts), M25 cable entry versions are available for hoods and angled bulkhead housings.

- Locking lever in **blue**-coloured, hygienic grade, self-extinguishing thermoplastic material; detectable by metal detectors in case of accidental loss and falls inside the conveyor belt (food path).
- Housings with incorporated **blue**-coloured flange gasket in hygienic grade elastomer.
- Hoods MKGH VA25 with a **blue**-coloured glued gasket in hygienic grade elastomer.

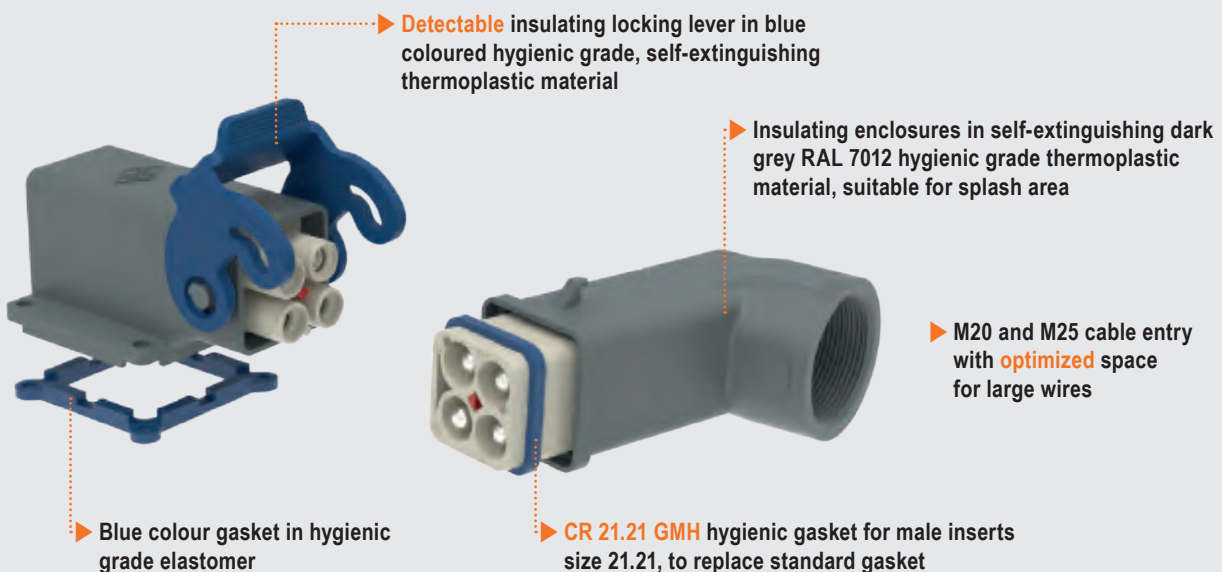
- CR 21.21 GMH **blue**-coloured sealing gasket for male inserts replacing the standard NBR one included in each hood package.
- Suitable for use either indoors or outdoors; degree of protection according to EN 60529: IP66 / IP67 / IP69 with CKRH 65 fixing screw and gasket kit (separately available) and suitably IP-rated cable outlet device.

✓ MARKINGS AND APPROVALS

- CE and UKA markings, EAC not applicable
- cULus (ECBT2/ECBT8)
- Type 12, Type 4 and 4X when using CKRH 65 kit
- CQC, DNV and BV (as accessories) pending
- RoHS: compliant

FOCUS

Housings' features



HYGIENIC series for food and beverage

 size **21.21**

Housings – 1 lever

Specialized Applications


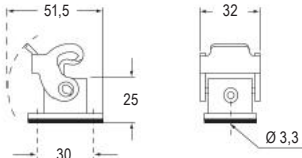


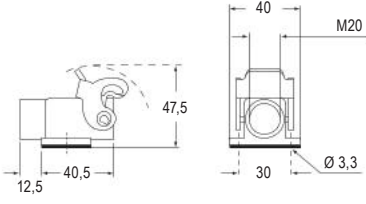

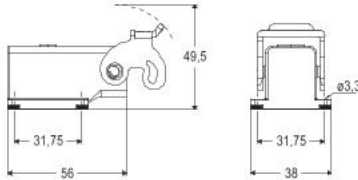

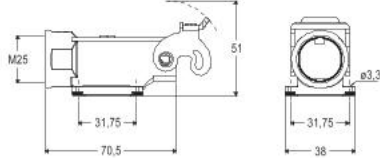

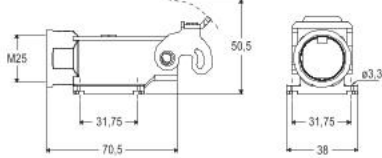


EN 60529	IP44
With CKRH 65	IP66 / IP67 / IP69
UL 50 / UL 50E	Type 12
With CKRH 65	Type 4 / 4X
Ambient temperature limits	-40 °C ... +70 °C
Mechanical life (cycles)	≥ 500



(pending: CQC, DNV and BV)

ECBT2.E115072 | ECBT8.E115072

Item	Description	Part No.	Entry	Dimension
	Bulkhead mounting housings, 1 lever	CKH 03 I		
 	Angled bulkhead mounting housings, 1 lever, with or without cable entry Not suitable for CQ4 series inserts	Without cable entry CKH 03 IA With cable entry MKH IAP20	M20	
	Angled insulating bulkhead mounting housing, 1 lever, fixing by 4 screws	CKH 03 IA4		
	Angled insulating bulkhead mounting housing, 1 lever, with open bottom flange, M25 cable entry, fixing by 4 screws	MKH IAP25	M25	
	Angled insulating surface mounting housing, 1 lever, with closed bottom flange, M25 cable entry, fixing by 4 screws	MKH AP25	M25	

Compact 21.21 Inserts	Poles	Pages
CQ4 / CQ / CQY	40 A to 6,5 A	A.4-12
CK / JK / CKSH	10 A	A.16-19
CD / CDY	10 A	A.22-23
CD / CDY	10 A	A.24-25
CJ (RJ45)	1 A to 2,1 A	A.30-33
CUK (USB)	-	A.36
CX (BUS)	10 A	A.37
CLK (Fibre optics)	-	A.38

Notes:
CKRH 65 included with all hoods and housings, to replace the fixing screw provided with the insert.

Accessories:



AH M25 / AH M32
HYGIENIC cable glands
Page [E.249](#)



HYGIENIC series for food and beverage

size **21.21**

Hoods and covers – 1 lever


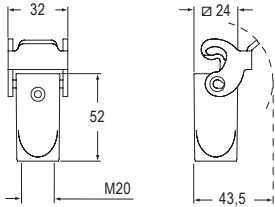

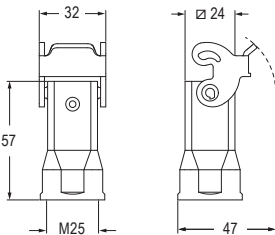
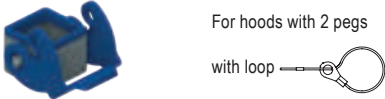

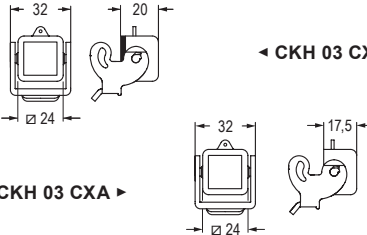
Specialized Applications

EN 60529	IP44
With CKRH 65	IP66 / IP67 / IP69
UL 50 / UL 50E	Type 12
With CKRH 65	Type 4 / 4X
Ambient temperature limits	-40 °C ... +70 °C
Mechanical life (cycles)	≥ 500



(pending: CQC, DNV and BV)

ECBT2.E115072 | ECBT8.E115072

Item	Description	Part No.	Entry	Dimension
	Hoods, 1 lever, top entry Not suitable for CQ4 series inserts	MKH VG20	M20	
	Hoods, 1 lever, top entry	MKH VG25	M25	
	Covers, 1 lever, with or without gasket For hoods with 2 pegs with loop 	With gasket (for female inserts) CKH 03 CX Without gasket (for male inserts) CKH 03 CXA		

CKH / MKH

A

Compact 21.21 Inserts	Poles	Pages
CQ4 / CQ / CQY	40 A to 6,5 A	2 to 21 + ☺
CK / JK / CKSH	10 A	3 to 4 + ☺
CD / CDY	10 A	7 + ☺
CD / CDY	10 A	8
CJ (RJ45)	1 A to 2,1 A	–
CUK (USB)	–	–
CX (BUS)	10 A	–
CLK (Fibre optics)	–	4

Notes:
CKRH 65 included with all hoods and housings, to replace the fixing screw provided with the insert.

Accessories:



AH M25 / AH M32
HYGIENIC cable glands
Page E.249

HYGIENIC series for food and beverage

 size **21.21**

Hoods and covers – 2 pegs

Specialized Applications


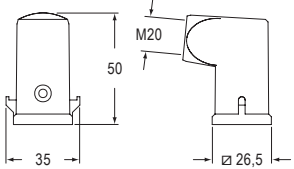

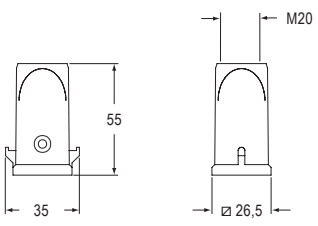

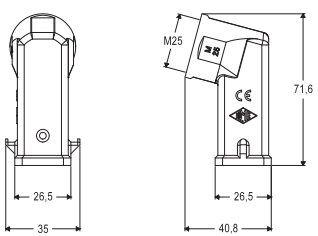

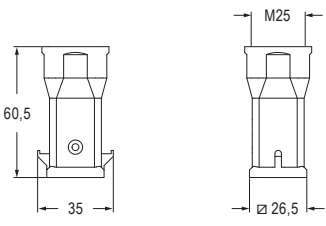


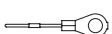
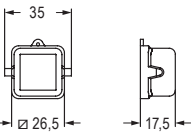


EN 60529	IP44
With CKRH 65	IP66 / IP67 / IP69
UL 50 / UL 50E	Type 12
With CKRH 65	Type 4 / 4X
Ambient temperature limits	-40 °C ... +70 °C
Mechanical life (cycles)	≥ 500



(pending: CQC, DNV and BV)

ECBT2.E115072 | ECBT8.E115072

Item	Description	Part No.	Entry	Dimension
	Hoods, 2 pegs, side entry, with CR 21.21 GMH gasket DESINA® version also available, with glued gasket, suitable for male inserts without gasket Not suitable for CQ4 series inserts	With CR 21.21 GMH gasket MKH VA20	M20	
		DESINA® with glued gasket MKGH VA20	M20	
	Hoods, 2 pegs, top entry, with CR 21.21 GMH gasket DESINA® version also available, with glued gasket, suitable for male inserts without gasket Not suitable for CQ4 series inserts	With CR 21.21 GMH gasket MKH V20	M20	
		DESINA® with glued gasket MKGH V20	M20	
	Hoods, 2 pegs, side entry, with CR 21.21 GMH gasket DESINA® version also available, with glued gasket, suitable for male inserts without gasket	With CR 21.21 GMH gasket MKH VA25	M25	
		DESINA® with glued gasket MKGH VA25	M25	
	Hoods, 2 pegs, top entry, with CR 21.21 GMH gasket DESINA® version also available, with glued gasket, suitable for male inserts without gasket	With CR 21.21 GMH gasket MKH V25	M25	
		DESINA® with glued gasket MKGH V25	M25	
	Covers, 2 pegs, with or without gasket For enclosures with 1 lever with loop for hoods  or with eyelet for housings 	With loop With gasket (for female inserts) CKH 03 CS	With eyelet CKH 03 C	
		Without gasket (for male inserts) CKH 03 CAS	CKH 03 CA	

Compact 21.21 Inserts	Poles	Pages
CQ4 / CQ / CQY	40 A to 6,5 A	A.4-12
CK / JK / CKSH	10 A	A.16-19
CD / CDY	10 A	A.22-23
CD / CDY	10 A	A.24-25
CJ (RJ45)	1 A to 2,1 A	A.30-33
CUK (USB)	-	A.36
CX (BUS)	10 A	A.37
CLK (Fibre optics)	-	A.38

Notes:
 CKRH 65 included with all hoods and housings, to replace the fixing screw provided with the insert.

Accessories:


AH M25 / AH M32
 HYGIENIC cable glands
 Page E.249



HYGIENIC series for food and beverage

size **21.21**


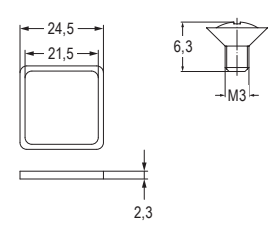
Accessories

Specialized Applications

CE UK

(pending: CQC, DNV and BV)

ECBT2.E115072 | ECBT8.E115072

Item	Description	Part No.	Dimension
	<p>Gasket and screw kit:</p> <p>HYGIENIC gasket for male inserts 21.21 size</p> <p>+</p> <p>Screw</p>	<p>Gasket only</p> <p>CR 21.21 GMH</p> <p>Kit for IP66 / IP67 / IP69</p> <p>CKRH 65</p>	

CKH / MKH

A

Panel cut-out drawings

For 21.21 sized bulkhead mounting housings

To guarantee the declared IP degree of protection of the housings reported in this catalogue, according to EN IEC 60529 or to the relevant Type rating per ANSI/UL 50 and 50E (for those products bearing approval to those ratings), the surface of the mounting panel must meet the following requirements (definitions are provided in ISO 4287 standard):

Waviness $Wt \leq 0,2$ mm over a distance of 200 mm
(measured on the panel without load)

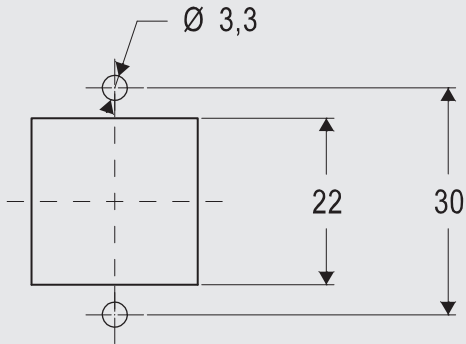
Roughness $Ra \leq 16$ μm

Scale 1:1

Enclosures size 21.21

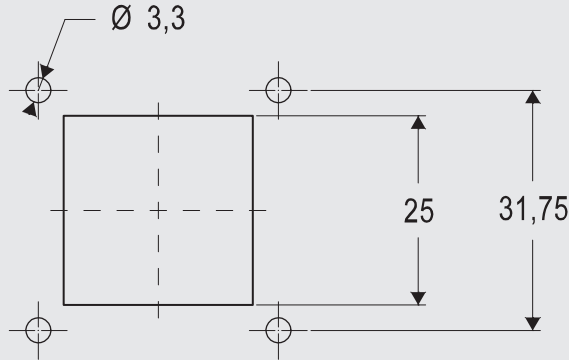
A

Size 21.21 fixing by 2 screws



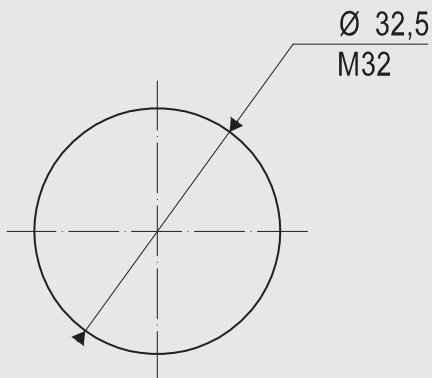
Required screws: 2
Screws size: M3
Recommended torque:
0,8 – 1,0 Nm / 7.1 – 8.9 lb.in

Size 21.21 fixing by 4 screws

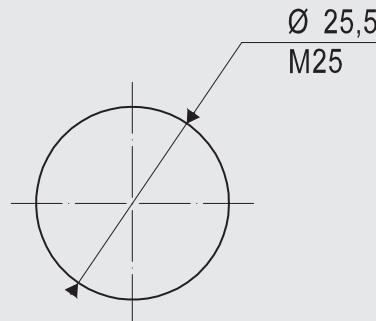


Required screws: 4
Screws size: M3
Recommended torque:
0,8 – 1,0 Nm / 7.1 – 8.9 lb.in

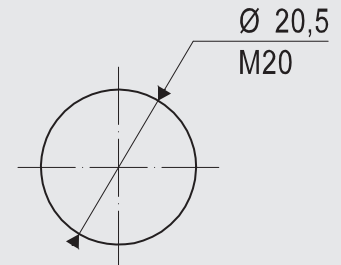
Size 21.21 with M32 fixing thread



Size 21.21 with M25 fixing thread



Size 21.21 with M20 fixing thread



Notes: The values of tightening torque indicated above are just recommended values, that must be related – by the designer of the final application – to the resistance class of the screws (not included), with the assumption that the mounting panel is sufficiently rigid (stiff). If the deflection of the panel, under the effect of tightening the screws, is greater than 0,7 mm over a distance of 100 mm, it is

necessary to use the counter-flanges mentioned in our catalogue or the special flange gaskets available upon request (please contact our Sales Department).

Panel cut-out drawings

For 21.21 sized bulkhead mounting housings

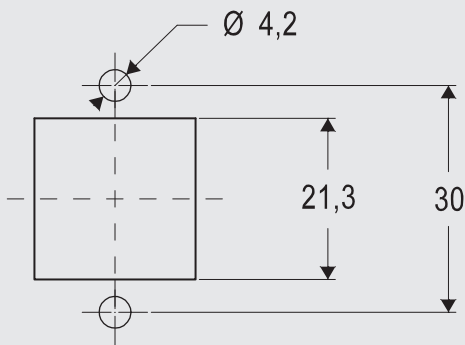
To guarantee the declared IP degree of protection of the housings reported in this catalogue, according to EN IEC 60529 or to the relevant Type rating per ANSI/UL 50 and 50E (for those products bearing approval to those ratings), the surface of the mounting panel must meet the following requirements (definitions are provided in ISO 4287 standard):

Waviness $W_t \leq 0,2$ mm over a distance of 200 mm
(measured on the panel without load)

Roughness $R_a \leq 16$ μm

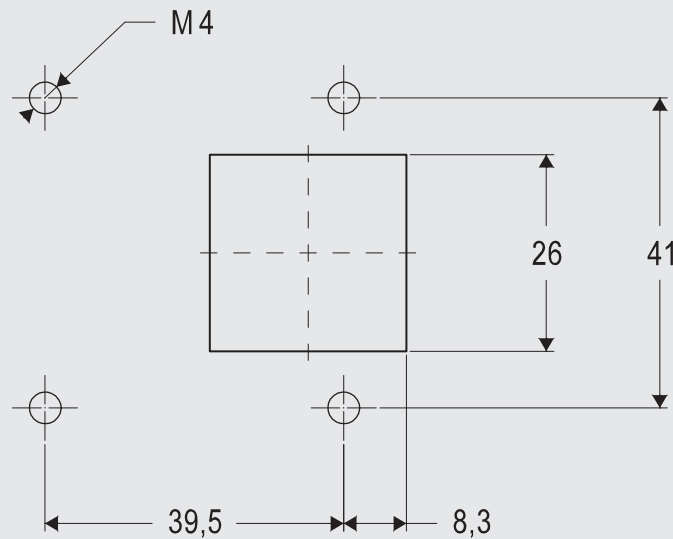
Scale 1:1

Size 21.21 IP68 high protection: CGK I, CGK I B



Required screws: 2
Screws size: M4
Recommended torque:
0,8 – 1,2 Nm / 7.1 – 10.6 lb.in

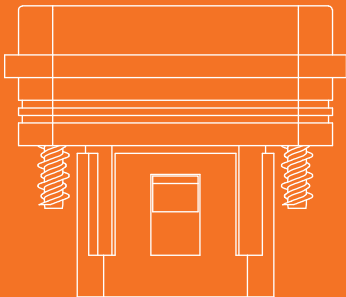
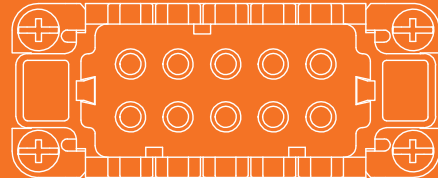
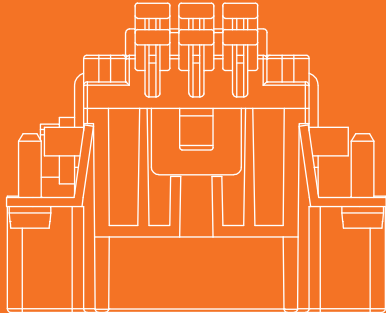
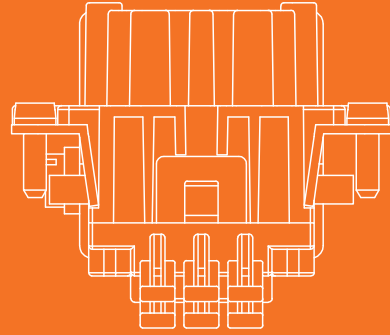
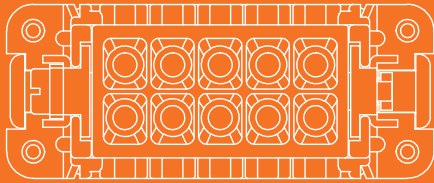
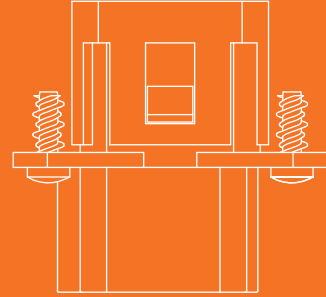
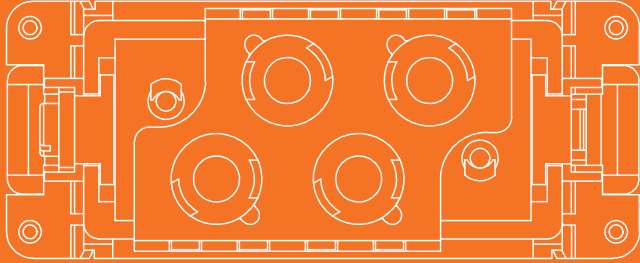
Size 21.21 IP68 high protection: MGK IAP, CGK IAP, CGK IA



Required screws: 4
Screws size: M4
Recommended torque:
0,8 – 1,2 Nm / 7.1 – 10.6 lb.in

Notes: The values of tightening torque indicated above are just recommended values, that must be related – by the designer of the final application – to the resistance class of the screws (not included), with the assumption that the mounting panel is sufficiently rigid (stiff). If the deflection of the panel, under the effect of tightening the screws, is greater than 0,7 mm over a distance of 100 mm, it is

necessary to use the counter-flanges mentioned in our catalogue or the special flange gaskets available upon request (please contact our Sales Department). For the CGI/MGI IP68 enclosures the specific counter-flanges mentioned in the catalogue are always recommended.

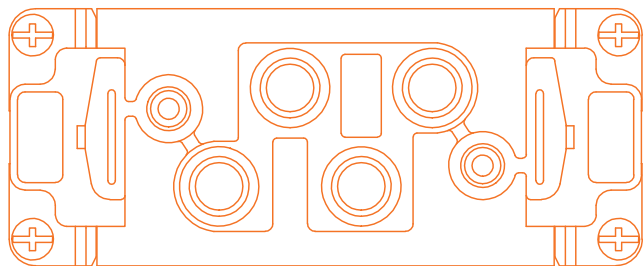
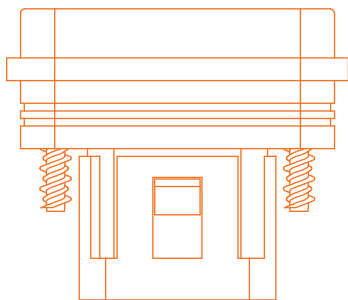
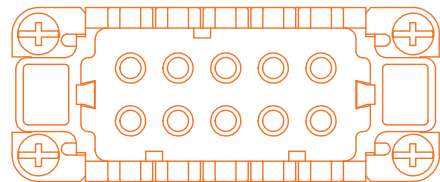
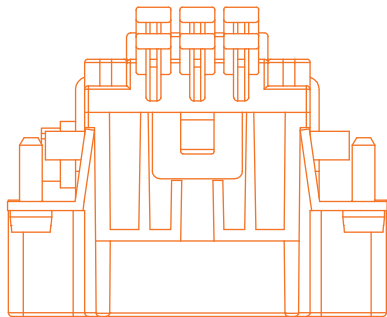
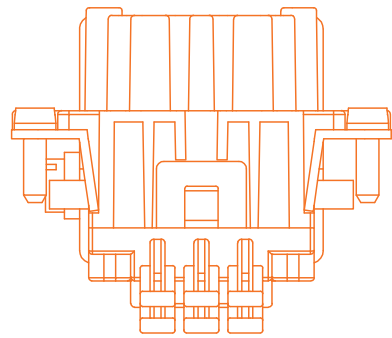
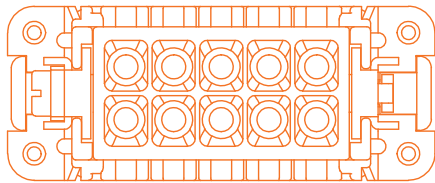
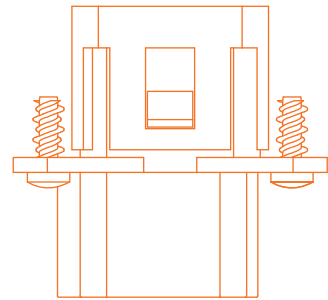
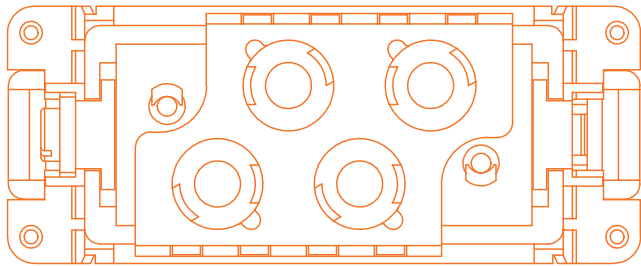


GENERAL CATALOGUE

Standard inserts

Contents

32.13 inserts	Size 32.13	B.4
	CQ / CQY series - 40 A crimp B.6-8 - 16 A crimp / tool-less AXYR® B.9-11 - 10 A crimp B.12	
Slim inserts	Size 49.16, 66.16 and 66.40	B.14
	CDA / CDC / series - 16 A screw / crimp B.16-21	
	CSAH series - 16 A tool-less SQUICH® B.24-26	B.22
	CD / CDD series - 10 A crimp B.30-34	B.28
Standard inserts	Size 44.27, 57.27, 77.27, 104.27, 77.62 and 104.62	B.36
	CNE / CCE series - 16 A screw / crimp B.38-49	
	CSH / JSH...S series - 16 A tool-less SQUICH® B.52-63	B.50
	CSHT series - 16 A tool-less SQUICH® B.66-68	B.64
	CQE / CQEE series - 16 A crimp B.72-79	B.70
	CQEY series - 16 A tool-less AXYR® B.82-87	B.80
	CD / CDD series - 10 A crimp B.90-99	B.88
	CDSH series - 10 A tool-less SQUICH® B.102-107	B.100
	CDSH 06 NC - 6 A tool-less SQUICH® B.108-109	



GENERAL CATALOGUE

Standard inserts

Contents

Standard inserts	Size 44.27, 57.27, 77.27, 104.27, 77.62 and 104.62	B.110
	CP / CPY series - 35 A screw B.112-113 - 35 A tool-less AXYR® B.114-115	
	CSS series - 16 A spring B.118-123	B.116
	CT / CTSE series with terminal block - 16 A screw / spring B.126-135	B.124
	CT / CTS series with terminal block - 10 A screw / spring B.138-141	B.136
	CMCE / CMSH for High Voltage – 830 V - 16 A crimp B.144-148 - 16 A tool-less SQUICH® B.149-153	B.142
Combined inserts	Size 44.27, 57.27, 77.27 and 104.27	B.154
	CX / CXC series - 100 A crimp B.156-157 - 80 A screw / crimp B.158-162 - 40 A crimp B.163-164	
	CX series - 40 A crimp B.168-169 - 16 A crimp B.170-171	B.166

CQ size 32.13 series



The CQ series inserts size 32.13 provides a compact serial connection for drives

CQ series overview

The CQ inserts size 32.13 provide a compact serial connection for controls and power supplies, specifically suitable for decentralized drive systems in motion and industry applications.

Adopted initially as a connector form factor for the **DESINA®** (**DE**centralised and **ST**andardised **IN**stallation technology), they find an extensive application range thanks to the compact overall dimension and wiring simplicity.

The standard insert for drives control is the CQ 08, which, with 8 poles + \oplus (16 A, 500 V) and CC series crimp contacts, provides the option of a power connection and additional wiring of motor brakes, sensors or safety thermistors.

PE wiring for 32.13 inserts

Enclosures series size 32.13 are available in thermoplastic and metallic material. While no enclosure earthing is needed for the thermoplastic hoods and housings, the metallic version requires proper bonding to protective earth (PE) for safety reasons, in line with the mandatory CE marking statement for such devices.

The connector inserts CQ 04/2E, CQ 08E and CQY 08E provide such bonding via a newly introduced PE plate reliably in contact with their male or female PE contact.

Each insert has been designed with coding keys that match only with the corresponding keyways of the metallic enclosures to avoid possibly hazardous mounting of connector inserts not having PE plate (i.e., CQF /M 08, CQF /M 04/2, CQF /M 17).

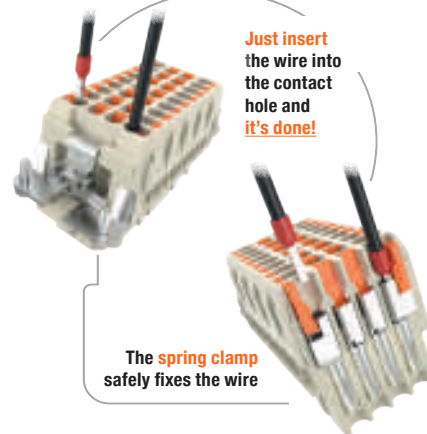


Watch our clip

KEY FEATURES

- > **PCB interface adapter (for CQ 04/2, CQ 08, CQ 17 crimp inserts)** suitable for printed circuit board application by soldering to PCBs with thickness up to 2,4 mm (see page D.10).
- > **High-density tool-less AXYR® CQY 08 insert** (compatible with the corresponding crimp versions) for prepared and unprepared conductor up to 4 mm² wire cross section.
- > **Optional coding pins** CR 08 Q08E for CQ 04/E and CQ 08E or CR CP for CQ 17 inserts.

TECHNOLOGY
AT A GLANCE

AXYR®


CQ / CQY series

B

FOCUS

Inserts' technology



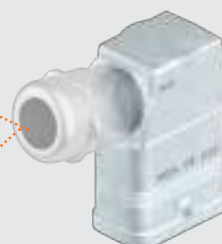
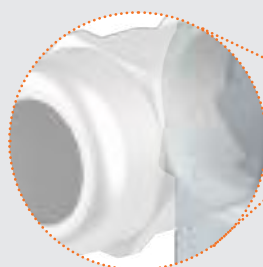
- ▶ CR Q08E optional plastic coding pins for up to 6 configurations
- ▶ 4 pins required to unequivocally code a coupling



▶ AXYR® CQF 08E with integrated PE plate for bonding to PE of metallic enclosures



- ▶ MQA 08 O25 / V25 ribs, on both sides, to prevent incompatible use of 32.13 inserts without integrated PE plate for hoods and housings



- ▶ M25 thread, possibility to use a standard or EMC complete cable gland

CQ 04/2E

40 A 400/690 V / 10 A 250 V

size **32.13**
4 / 2 poles + ⊕

Crimp connection

ISO 23570-3 standard and DESINA® specification compliant



EN 61984 rating	40 A 400 / 690 V 6 kV 3	10 A 250 V 4 kV 3
Rated voltage (UL / CSA)	600 V	
Insulation resistance	≥ 10 GΩ	
Contact resistance	40 A (4 poles) ≤ 0,3 mΩ	10 A (2 poles) ≤ 3 mΩ
Ambient temperature limit	-40 °C ... +125 °C	
Mechanical life (cycles)	≥ 500	



(pending: CQC, DNV and BV)

(pending: cURus)

Item	Description	Part No.	Dimension
	Male inserts for male contacts, with integrated PE plate Without contacts (to be ordered separately) Supplied with 2 fixing screws, self-tapping, zinc plated steel ø 2,9 x 9,5 mm, Ph1	CQM 04/2E	

	Female inserts for female contacts, with integrated PE plate Without contacts (to be ordered separately) Supplied with 2 fixing screws, self-tapping, zinc plated steel ø 2,9 x 9,5 mm, Ph1	CQF 04/2E	
--	---	---------------------------	--

Item	Description	Part No.		Dimension	
		Male	Female		
	40 A crimp contacts section (mm ²) section (AWG)	silver	CXMA 1.5	CXFA 1.5	
			CXMA 2.5	CXFA 2.5	
			CXMA 4.0	CXFA 4.0	
			CXMA 6.0	CXFA 6.0	
			CXMA 6.0	CXFA 6.0	
	10 A crimp contacts section (mm ²) section (AWG)	silver	CDMA 0.3	CDFA 0.3	
			CDMA 0.5	CDFA 0.5	
			CDMA 0.7	CDFA 0.7	
			CDMA 1.0	CDFA 1.0	
			CDMA 1.5	CDFA 1.5	
		CDMA 2.5	CDFA 2.5		
		gold	CDMD 0.3	CDFD 0.3	
			CDMD 0.5	CDFD 0.5	
			CDMD 0.7	CDFD 0.7	
			CDMD 1.0	CDFD 1.0	
CDMD 1.5	CDFD 1.5				
CDMD 2.5	CDFD 2.5				

Wiring information, CX and CD contacts

conductor section (mm ²)	conductor slot ø A (mm)	stripping length B (mm)	conductor section (mm ²)	conductor slot ø C (mm)	stripping length D (mm)
1,5	1,8	9	0,14-0,37	0,9	8
2,5	2,2	9	0,5	1,1	8
4	2,85	9,6	0,75	1,3	8
6	3,5	9,6	1,0	1,45	8
-	-	-	1,5	1,8	8
-	-	-	2,5	2,2	6


Wire diameter: up to 5,3 mm (CX series); up to 3,8 mm (CD series).

For basic or high thickness gold plating, please refer to page [E.16](#)

It is recommended to use the crimping tools and removal tools homologated by ILME (please see page [E.23](#))

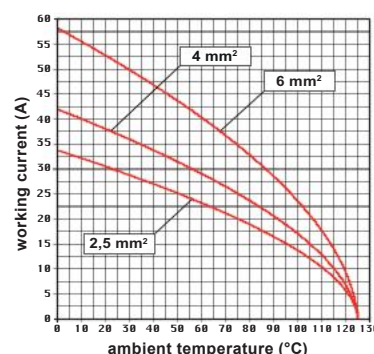
Materials

Insert	polycarbonate (PC)
UL 94 flame rating	V-0
Colour	pebble grey, RAL 7032
Contacts	copper alloy, silver ● and gold ● plated



CIF Q4/2.2.4
PCB adapter
Page [D.10](#)

Enclosures size 32.13	Pages
Heavy-Duty Applications	
Thermoplastic	E.6-7
Specialized Applications	
Thermoplastic EMC (Electromagnetic Shielding)	E.8-9
Metallic EMC (Electromagnetic Shielding)	E.10



CQ 04/2E inserts max. current load derating diagram

CQ 04/2

40 A 400/690 V / 10 A 250 V

size **32.13**
4 / 2 poles + ⊕

Crimp connection

EN 61984 rating	40 A 400 / 690 V 6 kV 3	10 A 250 V 4 kV 3
Rated voltage (UL / CSA)	600 V	
Insulation resistance	≥ 10 GΩ	
Contact resistance	40 A (4 poles)	≤ 0,3 mΩ
	10 A (2 poles)	≤ 3 mΩ
Ambient temperature limit	-40 °C ... +125 °C	
Mechanical life (cycles)	≥ 500	

ISO 23570-3 standard
and DESINA®
specification compliant



ECBT2.E115072 | ECBT8.E115072
PVVA2.E506437 | PVVA8.E506437

Item	Description	Part No.	Dimension
	Male inserts for male contacts Without contacts (to be ordered separately) Supplied with 2 fixing screws, self-tapping, zinc plated steel ø 2,9 × 9,5 mm, Ph1	CQM 04/2	

	Female inserts for female contacts Without contacts (to be ordered separately) Supplied with 2 fixing screws, self-tapping, zinc plated steel ø 2,9 × 9,5 mm, Ph1	CQF 04/2	
--	---	--------------------------	--

	40 A crimp contacts		Male	Female	
	section (mm ²)	section (AWG)			
	1,5	16	silver	CXMA 1.5	CXFA 1.5
	2,5	14		CXMA 2.5	CXFA 2.5
	4	12		CXMA 4.0	CXFA 4.0
	6	10		CXMA 6.0	CXFA 6.0
	10 A crimp contacts		silver	CDMA 0.3	CDFA 0.3
	section (mm ²)	section (AWG)		CDMA 0.5	CDFA 0.5
	0,14-0,37	26-22		CDMA 0.7	CDFA 0.7
	0,5	20		CDMA 1.0	CDFA 1.0
	0,75	18		CDMA 1.5	CDFA 1.5
	1	18		CDMA 2.5	CDFA 2.5
	10 A crimp contacts		gold	CDMD 0.3	CDFD 0.3
	section (mm ²)	section (AWG)		CDMD 0.5	CDFD 0.5
	0,14-0,37	26-22		CDMD 0.7	CDFD 0.7
	0,5	20		CDMD 1.0	CDFD 1.0
	0,75	18		CDMD 1.5	CDFD 1.5
	1	18		CDMD 2.5	CDFD 2.5

Wiring information, CX and CD contacts

conductor section (mm ²)	conductor slot ø A (mm)	stripping length B (mm)	conductor section (mm ²)	conductor slot ø C (mm)	stripping length D (mm)
1,5	1,8	9	0,14-0,37	0,9	8
2,5	2,2	9	0,5	1,1	8
4	2,85	9,6	0,75	1,3	8
6	3,5	9,6	1,0	1,45	8
-	-	-	1,5	1,8	8
-	-	-	2,5	2,2	6

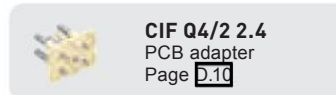
Wire diameter: up to 5,3 mm (CX series); up to 3,8 mm (CD series).

For basic or high thickness gold plating, please refer to page [E.14](#).

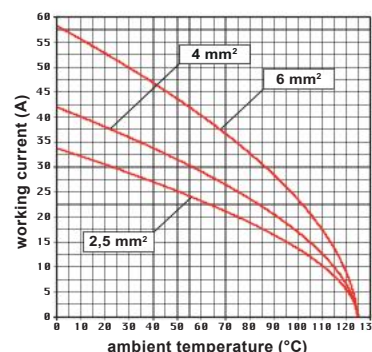
It is recommended to use the crimping tools and removal tools homologated by ILME (please see page [E.23](#)).

Materials

Insert	polycarbonate (PC)
UL 94 flame rating	V-0
Colour	pebble grey, RAL 7032
Contacts	copper alloy, silver ● and gold ● plated



Enclosures size 32.13	Pages
Heavy-Duty Applications	
Thermoplastic	E.6-7
Specialized Applications	
Thermoplastic EMC (Electromagnetic Shielding)	E.8-9



CQ 04/2 inserts max. current load derating diagram

To be used only in 32.13 compact thermoplastic enclosures

dimensions shown in mm are not binding and may be changed without notice

CQ 04/2B

40 A 400/690 V / 10 A 250 V

size **32.13**
4 / 2 poles + ⊕

Crimp connection

ISO 23570-3 standard and DESINA® specification compliant



EN 61984 rating	40 A 400 / 690 V 6 kV 3	10 A 250 V 4 kV 3
Rated voltage (UL / CSA) (pending)	600 V	
Insulation resistance	≥ 10 GΩ	
Contact resistance	40 A (4 poles)	≤ 0,3 mΩ
	10 A (2 poles)	≤ 3 mΩ
Ambient temperature limit	-40 °C ... +125 °C	
Mechanical life (cycles)	≥ 500	

CE UK (pending: EAC)

(pending: CQC, DNV and BV)

(pending: cURus)

Item	Description	Part No.	Dimension
	Male inserts for male contacts Without contacts (to be ordered separately) Supplied with 2 fixing screws, self-tapping, zinc plated steel ø 2,9 × 9,5 mm, Ph1	CQM 04/2B	

	Female inserts for female contacts Without contacts (to be ordered separately) Supplied with 2 fixing screws, self-tapping, zinc plated steel ø 2,9 × 9,5 mm, Ph1	CQF 04/2B	
--	--	---------------------------	--

	40 A crimp contacts		Male	Female	
	section (mm ²)	section (AWG)			
	1,5	16	silver	CXMA 1.5	CXFA 1.5
	2,5	14		CXMA 2.5	CXFA 2.5
	4	12		CXMA 4.0	CXFA 4.0
	6	10		CXMA 6.0	CXFA 6.0
	10	8		CXMA 10	CXFA 10
	10 A crimp contacts		silver		
	section (mm ²)	section (AWG)			
	0,14-0,37	26-22		CDMA 0.3	CDFA 0.3
	0,5	20		CDMA 0.5	CDFA 0.5
	0,75	18		CDMA 0.7	CDFA 0.7
1	18	CDMA 1.0	CDFA 1.0		
1,5	16	CDMA 1.5	CDFA 1.5		
2,5	14	CDMA 2.5	CDFA 2.5		
	10 A crimp contacts		gold		
	section (mm ²)	section (AWG)			
	0,14-0,37	26-22		CDMD 0.3	CDFD 0.3
	0,5	20		CDMD 0.5	CDFD 0.5
	0,75	18		CDMD 0.7	CDFD 0.7
1	18	CDMD 1.0	CDFD 1.0		
1,5	16	CDMD 1.5	CDFD 1.5		
2,5	14	CDMD 2.5	CDFD 2.5		

Wiring information, CX and CD contacts

conductor section (mm ²)	conductor slot ø A (mm)	stripping length B (mm)	conductor section (mm ²)	conductor slot ø C (mm)	stripping length D (mm)
1,5	1,8	9	0,14-0,37	0,9	8
2,5	2,2	9	0,5	1,1	8
4	2,85	9,6	0,75	1,3	8
6	3,5	9,6	1,0	1,45	8
10	4,3	15	1,5	1,8	8
-	-	-	2,5	2,2	6

Wire diameter: up to 7 mm (CX series); up to 3,8 mm (CD series).

For basic or high thickness gold plating, please refer to page [E.16](#)

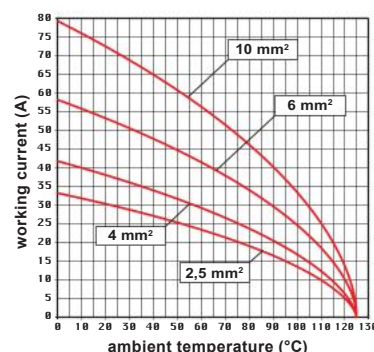
It is recommended to use the crimping tools and removal tools homologated by ILME (please see page [E.23](#))

Materials

Insert	polycarbonate (PC)
UL 94 flame rating	V-0
Colour	pebble grey, RAL 7032
Contacts	copper alloy, silver ● and gold ● plated

CIF Q4/2 2.4
PCB adapter
Page [D.10](#)

Enclosures size 32.13	Pages
Heavy-Duty Applications	
Thermoplastic	E.6-7
Specialized Applications	
Thermoplastic EMC (Electromagnetic Shielding)	E.8-9



CQ 04/2B inserts max. current load derating diagram

To be used only in 32.13 compact thermoplastic enclosures

CQ 08E

16 A 500 V

size 32.13

8 poles + ⊕

Crimp connection

 ISO 23570-3 standard
and DESINA®
specification compliant


EN 61984 rating	16 A 500 V 6 kV 3
	16 A 400 / 690 V 8 kV 2
Rated voltage (UL / CSA)	600 V
Insulation resistance	≥ 10 GΩ
Contact resistance	≤ 1 mΩ
Ambient temperature limit	-40 °C ... +125 °C
Mechanical life (cycles)	≥ 500

CE UK (pending: EAC)

(pending: CQC, DNV and BV)

(pending: cURus)

Item	Description	Part No.	Dimension
	Male inserts for male contacts, with integrated PE plate Without contacts (to be ordered separately) Supplied with 2 fixing screws, self-tapping, zinc plated steel $\varnothing 2,9 \times 9,5$ mm, Ph1	CQM 08E	

	Female inserts for female contacts, with integrated PE plate Without contacts (to be ordered separately) Supplied with 2 fixing screws, self-tapping, zinc plated steel $\varnothing 2,9 \times 9,5$ mm, Ph1	CQF 08E	
--	--	-------------------------	--

	16 A advanced opening contacts	Male	Female																												
	section (mm ²) section (AWG)																														
	0,5 20	CC 0.5 AN		 																											
	0,75 18	CC 0.7 AN																													
	1 18	CC 1.0 AN																													
	1,5 16	CC 1.5 AN																													
	2,5 14	CC 2.5 AN																													
	16 A crimp contacts																														
	section (mm ²) section (AWG)																														
	0,14-0,37 26-22	CCMA 0.3	CCFA 0.3	 Wiring information, CC contacts <table border="1"> <thead> <tr> <th>conductor section (mm²)</th> <th>conductor slot $\varnothing A$ (mm)</th> <th>stripping length (mm)</th> </tr> </thead> <tbody> <tr><td>0,14-0,37</td><td>0,9</td><td>7,5</td></tr> <tr><td>0,5</td><td>1,1</td><td>7,5</td></tr> <tr><td>0,75</td><td>1,3</td><td>7,5</td></tr> <tr><td>1,0</td><td>1,45</td><td>7,5</td></tr> <tr><td>1,5</td><td>1,8</td><td>7,5</td></tr> <tr><td>2,5</td><td>2,2</td><td>7,5</td></tr> <tr><td>3,0</td><td>2,55</td><td>7,5</td></tr> <tr><td>4,0</td><td>2,85</td><td>7,5</td></tr> </tbody> </table>	conductor section (mm ²)	conductor slot $\varnothing A$ (mm)	stripping length (mm)	0,14-0,37	0,9	7,5	0,5	1,1	7,5	0,75	1,3	7,5	1,0	1,45	7,5	1,5	1,8	7,5	2,5	2,2	7,5	3,0	2,55	7,5	4,0	2,85	7,5
conductor section (mm ²)	conductor slot $\varnothing A$ (mm)	stripping length (mm)																													
0,14-0,37	0,9	7,5																													
0,5	1,1	7,5																													
0,75	1,3	7,5																													
1,0	1,45	7,5																													
1,5	1,8	7,5																													
2,5	2,2	7,5																													
3,0	2,55	7,5																													
4,0	2,85	7,5																													
	0,5 20	CCMA 0.5	CCFA 0.5																												
	0,75 18	CCMA 0.7	CCFA 0.7																												
	1 18	CCMA 1.0	CCFA 1.0																												
	1,5 16	CCMA 1.5	CCFA 1.5																												
	2,5 14	CCMA 2.5	CCFA 2.5																												
	3 12	CCMA 3.0	CCFA 3.0																												
	4 12	CCMA 4.0	CCFA 4.0																												
	0,14-0,37 26-22	CCMD 0.3	CCFD 0.3																												
	0,5 20	CCMD 0.5	CCFD 0.5																												
	0,75 18	CCMD 0.7	CCFD 0.7																												
	1 18	CCMD 1.0	CCFD 1.0																												
	1,5 16	CCMD 1.5	CCFD 1.5																												
	2,5 14	CCMD 2.5	CCFD 2.5																												
	3 12	CCMD 3.0	CCFD 3.0																												
	4 12	CCMD 4.0	CCFD 4.0																												

Wiring information, CC contacts

conductor section (mm ²)	conductor slot $\varnothing A$ (mm)	stripping length (mm)
0,14-0,37	0,9	7,5
0,5	1,1	7,5
0,75	1,3	7,5
1,0	1,45	7,5
1,5	1,8	7,5
2,5	2,2	7,5
3,0	2,55	7,5
4,0	2,85	7,5

Wire diameter: up to 4,7 mm.

For basic or high thickness gold plating, please refer to page F.13.

It is recommended to use the crimping tools and removal tools homologated by ILME (please see page F.23)

Materials

Insert	polycarbonate (PC)
UL 94 flame rating	V-0
Colour	pebble grey, RAL 7032
Contacts	copper alloy, silver and gold plated


CIF Q08 1.6
PCB adapter
Page D.10

CR CPQ
Coding pins
Page G.3

CR Q08E
Coding pins
Page G.8

Enclosures size 32.13

Pages

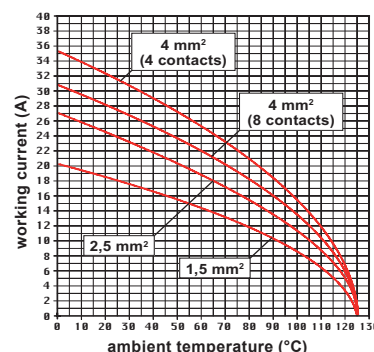
Heavy-Duty Applications

Thermoplastic E.6-7

Specialized Applications

Thermoplastic EMC (Electromagnetic Shielding) E.8-9

Metallic EMC (Electromagnetic Shielding) E.10


CQ 08E inserts max. current load derating diagram

Coded for use with 32.13 metallic enclosures

dimensions shown in mm are not binding and may be changed without notice

CQY 08E

16 A 500 V

size **32.13**

8 poles + ⊕

Tool-less connection – AXYR®


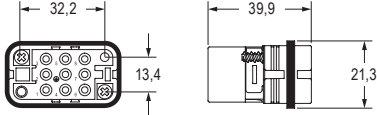

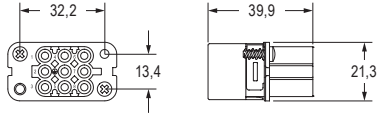
ISO 23570-3 standard and DESINA® specification compliant 

EN 61984 rating	16 A 500 V 6 kV 3
	16 A 400 / 690 V 8 kV 2
Rated voltage (UL / CSA)	600 V
Insulation resistance	≥ 10 GΩ
Contact resistance	≤ 3 mΩ
Ambient temperature limit	-40 °C ... +125 °C
Mechanical life (cycles)	≥ 500

CE UKRA (pending: EAC)

(pending: CQC, DNV and BV)

(pending: cURus)

Item	Description	Part No.	Dimension
	Male inserts with male contacts, with integrated PE plate Spring/AXYR® push-in connection Supplied with 2 fixing screws, self-tapping, zinc plated steel ø 2,9 × 9,5 mm, Ph1	CQYM 08E	
	Female inserts with female contacts, with integrated PE plate Spring/AXYR® push-in connection Supplied with 2 fixing screws, self-tapping, zinc plated steel ø 2,9 × 9,5 mm, Ph1	CQYF 08E	

CQ

B



Watch our clip



Materials

Insert	polycarbonate (PC)
UL 94 flame rating	V-0
Colour	pebble grey, RAL 7032
Contacts	built-in, copper alloy, silver ● plated

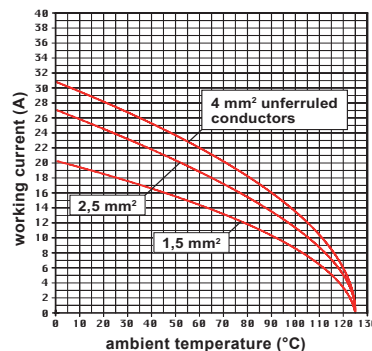
Wiring information

Wires cross sectional area	0,25 mm ² - 4 mm ² (AWG 24-12)
- unprepared	0,25 mm ² - 2,5 mm ² (AWG 24-14)
- prepared	9...11 mm
Stripping length	

Wire diameter: up to 5 mm.

 CIF Q08 1.6 PCB adapter Page D.10	 CR Q08E Coding pins Page G.8
--	---

Enclosures size 32.13	Pages
Heavy-Duty Applications	
Thermoplastic	E.6-7
Specialized Applications	
Thermoplastic EMC (Electromagnetic Shielding)	E.8-9
Metallic EMC (Electromagnetic Shielding)	E.10



CQY 08E inserts max. current load derating diagram

Coded for use with 32.13 metallic enclosures

CQ 08

16 A 500 V

size **32.13**
8 poles + ⊕

Crimp connection

ISO 23570-3 standard
and DESINA®
specification compliant



EN 61984 rating	16 A 500 V 6 kV 3
	16 A 400 / 690 V 8 kV 2
Rated voltage (UL / CSA)	600 V
Insulation resistance	≥ 10 GΩ
Contact resistance	≤ 3 mΩ
Ambient temperature limit	-40 °C ... +125 °C
Mechanical life (cycles)	≥ 500

CE UK EAC



ECBT2.E115072 | ECBT8.E115072
PVVA2.E506437 | PVVA8.E506437

Item	Description	Part No.	Dimension
	Male inserts for male contacts Without contacts (to be ordered separately) Supplied with 2 fixing screws, self-tapping, zinc plated steel ø 2,9 × 9,5 mm, Ph1	CQM 08	

	Female inserts for female contacts Without contacts (to be ordered separately) Supplied with 2 fixing screws, self-tapping, zinc plated steel ø 2,9 × 9,5 mm, Ph1	CQF 08	
--	---	------------------------	--

	16 A advanced opening contacts	Male	Female	
	section (mm ²) section (AWG)			
	0,5 20	CC 0.5 AN		
	0,75 18	CC 0.7 AN		
	1 18	CC 1.0 AN		
	1,5 16	CC 1.5 AN		
	2,5 14	CC 2.5 AN		
	16 A crimp contacts			
	section (mm ²) section (AWG)			
	0,14-0,37 26-22	CCMA 0.3	CCFA 0.3	
	0,5 20	CCMA 0.5	CCFA 0.5	
	0,75 18	CCMA 0.7	CCFA 0.7	
	1 18	CCMA 1.0	CCFA 1.0	
	1,5 16	CCMA 1.5	CCFA 1.5	
	2,5 14	CCMA 2.5	CCFA 2.5	
	3 12	CCMA 3.0	CCFA 3.0	
	4 12	CCMA 4.0	CCFA 4.0	
	0,14-0,37 26-22	CCMD 0.3	CCFD 0.3	
	0,5 20	CCMD 0.5	CCFD 0.5	
	0,75 18	CCMD 0.7	CCFD 0.7	
	1 18	CCMD 1.0	CCFD 1.0	
	1,5 16	CCMD 1.5	CCFD 1.5	
	2,5 14	CCMD 2.5	CCFD 2.5	
	3 12	CCMD 3.0	CCFD 3.0	
	4 12	CCMD 4.0	CCFD 4.0	

Wiring information, CC contacts

conductor section (mm ²)	conductor slot ø A (mm)	stripping length (mm)
0,14-0,37	0,9	7,5
0,5	1,1	7,5
0,75	1,3	7,5
1,0	1,45	7,5
1,5	1,8	7,5
2,5	2,2	7,5
3,0	2,55	7,5
4,0	2,85	7,5

Wire diameter: up to 4,7 mm.

For basic or high thickness gold plating, please refer to page [E.13](#).

It is recommended to use the crimping tools and removal tools homologated by ILME (please see page [E.23](#))

Materials

Insert	polycarbonate (PC)
UL 94 flame rating	V-0
Colour	pebble grey, RAL 7032
Contacts	copper alloy, silver ● and gold ● plated



CIF Q08 1.6
PCB adapter
Page [D.10](#)



CR CPQ
Coding pins
Page [E.3](#)

Enclosures size 32.13

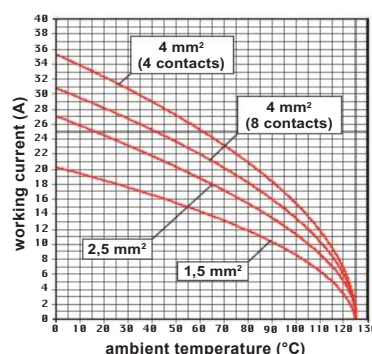
Pages

Heavy-Duty Applications

Thermoplastic	E.6-7
---------------	-----------------------

Specialized Applications

Thermoplastic EMC (Electromagnetic Shielding)	E.8-9
---	-----------------------



CQ 08 inserts max. current load derating diagram

- Can also be used partially fitted with 4 mm² section contacts;
- to be used only in 32.13 compact thermoplastic enclosures.

CQ 17

10 A 160 V

size **32.13**
17 poles + ⊕

Crimp connection

ISO 23570-3 standard and DESINA® specification compliant



EN 61984 rating	10 A 160 V 2,5 kV 3
	10 A 250 V 4 kV 2
Rated voltage (UL / CSA)	250 V
Insulation resistance	≥ 10 GΩ
Contact resistance	≤ 3 mΩ
Ambient temperature limit	-40 °C ... +125 °C
Mechanical life (cycles)	≥ 500

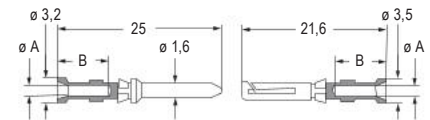


ILME ECBT2.E115072 | ECBT8.E115072

Item	Description	Part No.	Dimension
	Male inserts for male contacts Without contacts (to be ordered separately) Supplied with 2 fixing screws, self-tapping, zinc plated steel ø 2,9 × 9,5 mm, Ph1	CQM 17	

	Female inserts for female contacts Without contacts (to be ordered separately) Supplied with 2 fixing screws, self-tapping, zinc plated steel ø 2,9 × 9,5 mm, Ph1	CQF 17	
--	--	------------------------	--

10 A crimp contacts		Male	Female
section (mm ²)	section (AWG)		
0,14-0,37	26-22	CDMA 0.3	CDFA 0.3
0,5	20	CDMA 0.5	CDFA 0.5
0,75	18	CDMA 0.7	CDFA 0.7
1	18	CDMA 1.0	CDFA 1.0
1,5	16	CDMA 1.5	CDFA 1.5
2,5	14	CDMA 2.5	CDFA 2.5
		silver	
0,14-0,37	26-22	CDMD 0.3	CDFD 0.3
0,5	20	CDMD 0.5	CDFD 0.5
0,75	18	CDMD 0.7	CDFD 0.7
1	18	CDMD 1.0	CDFD 1.0
1,5	16	CDMD 1.5	CDFD 1.5
2,5	14	CDMD 2.5	CDFD 2.5
		gold	



Wiring information, CD contacts

conductor section (mm ²)	conductor slot ø A (mm)	stripping length B (mm)
0,14-0,37	0,9	8
0,5	1,1	8
0,75	1,3	8
1,0	1,45	8
1,5	1,8	8
2,5	2,2	6

Wire diameter: up to 3,8 mm.

For basic or high thickness gold plating, please refer to page [E.16](#)

For stamped crimp contacts (SD series), please refer to page [E.18](#)

It is recommended to use the crimping tools and removal tools homologated by ILME (please see page [E.23](#))

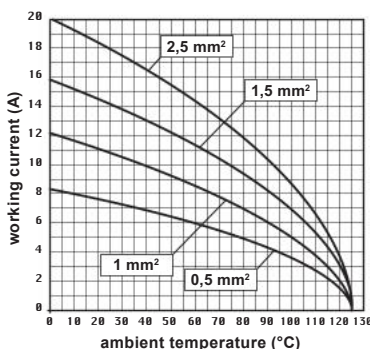
Materials

Insert	polycarbonate (PC)
UL 94 flame rating	V-0
Colour	pebble grey, RAL 7032
Contacts	copper alloy, silver ● and gold ● plated

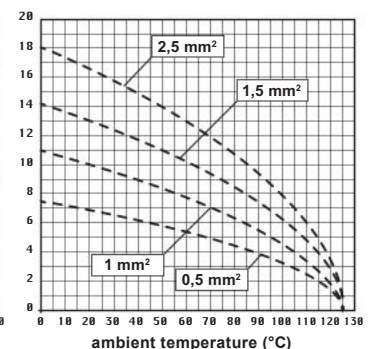
CR CP
Coding pins
Page [E.3](#)

Enclosures size 32.13	Pages
Heavy-Duty Applications	
Thermoplastic	E.6-7
Specialized Applications	
Thermoplastic EMC (Electromagnetic Shielding)	E.8-9

CQ 17 inserts max. current load derating diagram, turned contacts



CQ 17 inserts max. current load derating diagram, stamped contacts



- Seat of PE contact on female insert set forward to obtain pre-leading PE;
- to be used only in 32.13 compact thermoplastic enclosures.



B

CDA-CDC series



CDA and CDC series overview

CDA and CDC inserts and their enclosures are used in accordance with the recommendations EUROMAP 12, EUROMAP 13, EUROMAP 14-1, EUROMAP 16 and EUROMAP 62 (European industry consortium for moulding machines and plastic processing).

The CDC inserts can also be used with CC series crimp contacts made of iron/constantan (Fe-CuNi) for the cabling of type J thermocouples in accordance with IEC/EN 60584-1 (EUROMAP 14-1 recommendation).

SUM-UP

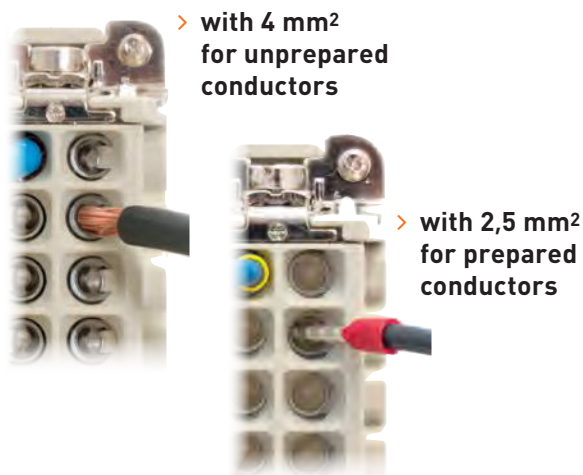
- > **According to standard EN 61984:**
 - 16 A 250 V 4kV 3
 - 16 A 250 V 4kV 3
- > **Insulation resistance: $\geq 10 \text{ G}\Omega$**
- > **Ambient temperature limit:**
 - 40 °C ... +125 °C
- > **Construction material: UL 94 V-0 self-extinguishing thermoplastic resin**
- > **Mechanical life: ≥ 500 cycles**
- > **Built-in silver plated contacts (only CDA series)**

CDA inserts with screw-type termination

The CDA screw-type connector inserts series with 10 and 16 poles + \ominus are now made using screw-type terminals (CNE series) with a built-in wire protection pressure plate of proven reliability and practicality.

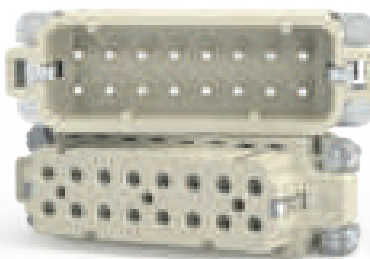
The wire protection pressure plate preserves the conductors in case of wiring with **unprepared conductors** (i.e. without wire end ferrules) up to a maximum wire cross-section of **4 mm²** (12 AWG).

The variant without a wire protection pressure plate (code with suffix X) is also available, for use with **prepared conductors** featuring a wire end ferrule with a maximum usable wire cross-section of **2,5 mm²** (14 AWG).



CDC inserts with crimp termination

The CDC crimp termination series of inserts with 10 and 16 poles + \ominus now adopt the tried and tested contact retention technique of connector series CCE and CQE for removable crimp contacts (series CC, max. 16 A).



FOCUS

Inserts' technology

- > CDC crimp termination inserts with 10 and 16 poles + \ominus with contact retention technique



CDA 10


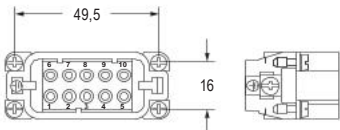

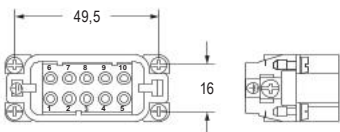

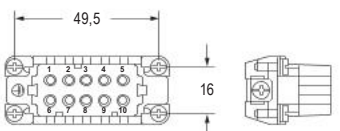

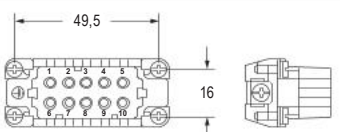
16 A 250 V

size **49.16**
10 poles + ⊕

Screw connection

EN 61984 rating	16 A 250 V 4 kV 3
	16 A 230 / 400 V 4 kV 2
Rated voltage (UL / CSA)	600 V
Insulation resistance	≥ 10 GΩ
Contact resistance	≤ 1 mΩ
Ambient temperature limit	-40 °C ... +125 °C
Mechanical life (cycles)	≥ 500



Item	Description	Part No.	Dimension
	Male inserts with male contacts With pressure plate For unprepared conductors	CDAM 10	
	Male inserts with male contacts Without pressure plate For prepared conductors	CDAM 10 X	
	Female inserts with female contacts With pressure plate For unprepared conductors	CDAF 10	
	Female inserts with female contacts Without pressure plate For prepared conductors	CDAF 10 X	

Materials

Insert	polycarbonate (PC)
UL 94 flame rating	V-0
Colour	pebble grey, RAL 7032
Contacts	built-in, copper alloy, silver ● plated

Wiring information

Wires cross sectional area	
- unprepared	0,5 mm ² - 4 mm ² (AWG 20-12)
- prepared	0,25 mm ² - 2,5 mm ² (AWG 24-14)
Stripping length	7 mm
Terminal screw torque	0,5 Nm (4.4 lb.in)

> For unprepared conductors with pressure plate

> For prepared conductors without pressure plate



Enclosures size 49.16

Heavy-Duty Applications

Metallic with IL-BRID lever	E.14-13
Metallic with JEI®-P lever	E.18
Metallic with Rigid IP67 lever	E.26

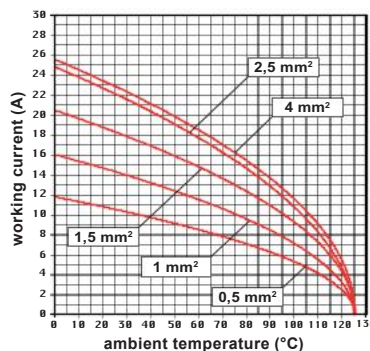
Aggressive Environments

Metallic W-TYPE	E.28-29
Metallic E-Xtreme®	E.34-35

Specialized Applications

EMC (Electromagnetic Shielding)	E.40-41
COB system for switch cabinet	E.290

Pages



CDA 10 inserts max. current load derating diagram

CDA 16

16 A 250 V

size 66.16

16 poles + ⊕

Screw connection

EN 61984 rating	16 A 250 V 4 kV 3
	16 A 230 / 400 V 4 kV 2
Rated voltage (UL / CSA)	600 V
Insulation resistance	≥ 10 GΩ
Contact resistance	≤ 1 mΩ
Ambient temperature limit	-40 °C ... +125 °C
Mechanical life (cycles)	≥ 500

ECBT2.E115072 | ECBT8.E115072

Item	Description	Part No.	Dimension
	Male inserts with male contacts With pressure plate For unprepared conductors	CDAM 16	
	Male inserts with male contacts Without pressure plate For prepared conductors	CDAM 16 X	
	Female inserts with female contacts With pressure plate For unprepared conductors	CDAF 16	
	Female inserts with female contacts Without pressure plate For prepared conductors	CDAF 16 X	

Materials

Insert	polycarbonate (PC)
UL 94 flame rating	V-0
Colour	pebble grey, RAL 7032
Contacts	built-in, copper alloy, silver ● plated

Wiring information

Wires cross sectional area	
- unprepared	0,5 mm ² - 4 mm ² (AWG 20-12)
- prepared	0,25 mm ² - 2,5 mm ² (AWG 24-14)
Stripping length	7 mm
Terminal screw torque	0,5 Nm (4.4 lb.in)

> For unprepared conductors
with pressure plate

> For prepared conductors
without pressure plate



Enclosures size 66.16

Pages

Heavy-Duty Applications

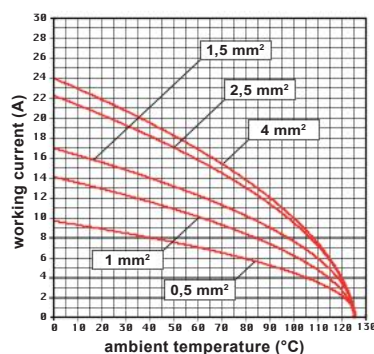
Metallic with IL-BRID lever	E.16-17
Metallic with JEI®-P lever	E.19
Metallic with RIGID IP67 lever	E.27

Aggressive Environments

Metallic W-TYPE	E.30-31
Metallic E-Xtreme®	E.36-37

Specialized Applications

EMC (Electromagnetic Shielding)	E.42-43
COB system for switch cabinet	E.290



CDA 16 inserts max. current
load derating diagram

CDA 16 + CDA 16 N

16 A 250 V

size **66.40**


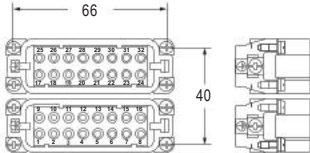

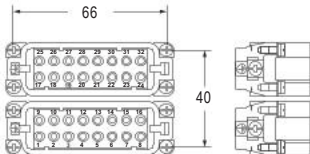

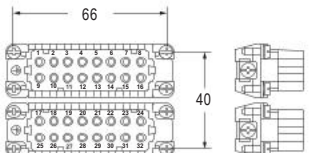

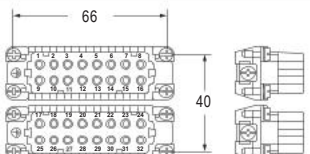
32 poles + ⊕

Screw connection

EN 61984 rating	16 A 250 V 4 kV 3
	16 A 230 / 400 V 4 kV 2
Rated voltage (UL / CSA)	600 V
Insulation resistance	≥ 10 GΩ
Contact resistance	≤ 1 mΩ
Ambient temperature limit	-40 °C ... +125 °C
Mechanical life (cycles)	≥ 500



CAIUS ECBT2.E115072 | ECBT8.E115072

Item	Description	Part No.	Dimension
	Male inserts, No. (1-16) Male inserts, No. (17-32) With pressure plate For unprepared conductors	CDAM 16 CDAM 16 N	
	Male inserts, No. (1-16) Male inserts, No. (17-32) Without pressure plate For prepared conductors	CDAM 16 X CDAM 16 XN	
	Female inserts, No. (1-16) Female inserts, No. (17-32) With pressure plate For unprepared conductors	CDAF 16 CDAF 16 N	
	Female inserts, No. (1-16) Female inserts, No. (17-32) Without pressure plate For prepared conductors	CDAF 16 X CDAF 16 XN	

Materials

Insert	polycarbonate (PC)
UL 94 flame rating	V-0
Colour	pebble grey, RAL 7032
Contacts	built-in, copper alloy, silver ● plated

Wiring information

Wires cross sectional area	
- unprepared	0,5 mm ² - 4 mm ² (AWG 20-12)
- prepared	0,25 mm ² - 2,5 mm ² (AWG 24-14)
Stripping length	7 mm
Terminal screw torque	0,5 Nm (4.4 lb.in)

> For unprepared conductors with pressure plate

> For prepared conductors without pressure plate



Enclosures size 66.40

Pages

Heavy-Duty Applications

Metallic with C-TYPE lever

[E.20-28](#)

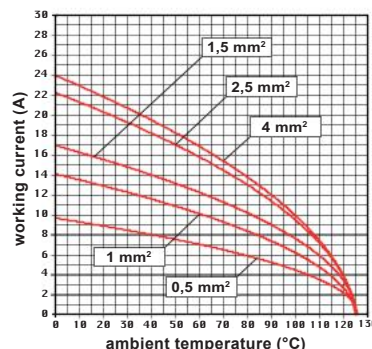
Aggressive Environments

Metallic W-TYPE with C-TYPE lever

[E.32-33](#)

Metallic E-Xtreme® with C-TYPE lever

[E.38-39](#)



CDA 16 inserts max. current load derating diagram

CDC 10

16 A 250 V

size 49.16

10 poles + ⊕

Crimp connection

EN 61984 rating	16 A 250 V 4 kV 3
	16 A 230 / 400 V 4 kV 2
Rated voltage (UL / CSA)	600 V
Insulation resistance	≥ 10 GΩ
Contact resistance	≤ 1 mΩ
Ambient temperature limit	-40 °C ... +125 °C
Mechanical life (cycles)	≥ 500

ECBT2.E115072 | ECBT8.E115072

Item	Description	Part No.	Dimension
	Male inserts for male contacts Without contacts (to be ordered separately)	CDCM 10	

	Female inserts for female contacts Without contacts (to be ordered separately)	CDCF 10	
--	--	-------------------------	--

	16 A advanced opening contacts	Male	Female	
	section (mm ²) section (AWG) 0,5 20 0,75 18 1 18 1,5 16 2,5 14	CC 0.5 AN CC 0.7 AN CC 1.0 AN CC 1.5 AN CC 2.5 AN		
	16 A crimp contacts section (mm ²) section (AWG) 0,14-0,37 26-22 0,5 20 0,75 18 1 18 1,5 16 2,5 14 3 12 4 12	CCMA 0.3 CCMA 0.5 CCMA 0.7 CCMA 1.0 CCMA 1.5 CCMA 2.5 CCMA 3.0 CCMA 4.0	CCFA 0.3 CCFA 0.5 CCFA 0.7 CCFA 1.0 CCFA 1.5 CCFA 2.5 CCFA 3.0 CCFA 4.0	
	0,14-0,37 26-22 0,5 20 0,75 18 1 18 1,5 16 2,5 14 3 12 4 12	CCMD 0.3 CCMD 0.5 CCMD 0.7 CCMD 1.0 CCMD 1.5 CCMD 2.5 CCMD 3.0 CCMD 4.0	CCFD 0.3 CCFD 0.5 CCFD 0.7 CCFD 1.0 CCFD 1.5 CCFD 2.5 CCFD 3.0 CCFD 4.0	

Wiring information, CC contacts

conductor section (mm ²)	conductor slot ø A (mm)	stripping length (mm)
0,14-0,37	0,9	7,5
0,5	1,1	7,5
0,75	1,3	7,5
1,0	1,45	7,5
1,5	1,8	7,5
2,5	2,2	7,5
3,0	2,55	7,5
4,0	2,85	7,5

Wire diameter: up to 4,7 mm.

For basic or high thickness gold plating, please refer to page [F.13](#).It is recommended to use the crimping tools and removal tools homologated by ILME (please see page [F.23](#))

Materials

Insert	polycarbonate (PC)
UL 94 flame rating	V-0
Colour	pebble grey, RAL 7032
Contacts	copper alloy, silver ● and gold ● plated



CR CPQ

Coding pins
Page [3.3](#)

Enclosures size 49.16

Pages

Heavy-Duty Applications

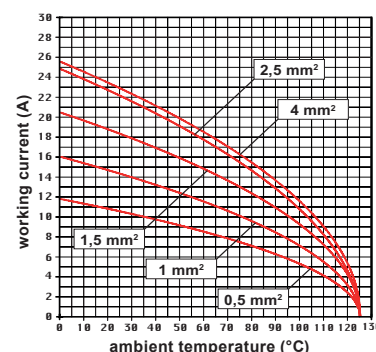
Metallic with IL-BRID lever	E.14-15
Metallic with JEI®-P lever	E.18
Metallic with Rigid IP67 lever	E.26

Aggressive Environments

Metallic W-TYPE	E.28-29
Metallic E-Xtreme®	E.34-35

Specialized Applications

EMC (Electromagnetic Shielding)	E.40-41
COB system for switch cabinet	E.29C



CDC 10 inserts max. current load derating diagram

CDC 16

16 A 250 V

size **66.16**
16 poles + ⊕

Crimp connection

EN 61984 rating	16 A 250 V 4 kV 3
	16 A 230 / 400 V 4 kV 2
Rated voltage (UL / CSA)	600 V
Insulation resistance	≥ 10 GΩ
Contact resistance	≤ 1 mΩ
Ambient temperature limit	-40 °C ... +125 °C
Mechanical life (cycles)	≥ 500



Item	Description	Part No.	Dimension
	Male inserts for male contacts Without contacts (to be ordered separately)	CDCM 16	

	Female inserts for female contacts Without contacts (to be ordered separately)	CDCF 16	
--	--	-------------------------	--

	16 A advanced opening contacts	Male	Female		
	section (mm ²) section (AWG) 0,5 20 0,75 18 1 18 1,5 16 2,5 14	silver CC 0.5 AN CC 0.7 AN CC 1.0 AN CC 1.5 AN CC 2.5 AN		CC AN	
	16 A crimp contacts section (mm ²) section (AWG) 0,14-0,37 26-22 0,5 20 0,75 18 1 18 1,5 16 2,5 14 3 12 4 12	silver CCMA 0.3 CCMA 0.5 CCMA 0.7 CCMA 1.0 CCMA 1.5 CCMA 2.5 CCMA 3.0 CCMA 4.0	CCFA 0.3 CCFA 0.5 CCFA 0.7 CCFA 1.0 CCFA 1.5 CCFA 2.5 CCFA 3.0 CCFA 4.0		CC
	0,14-0,37 26-22 0,5 20 0,75 18 1 18 1,5 16 2,5 14 3 12 4 12	gold CCMD 0.3 CCMD 0.5 CCMD 0.7 CCMD 1.0 CCMD 1.5 CCMD 2.5 CCMD 3.0 CCMD 4.0	CCFD 0.3 CCFD 0.5 CCFD 0.7 CCFD 1.0 CCFD 1.5 CCFD 2.5 CCFD 3.0 CCFD 4.0		CCMD

Wiring information, CC contacts

conductor section (mm ²)	conductor slot ø A (mm)	stripping length (mm)
0,14-0,37	0,9	7,5
0,5	1,1	7,5
0,75	1,3	7,5
1,0	1,45	7,5
1,5	1,8	7,5
2,5	2,2	7,5
3,0	2,55	7,5
4,0	2,85	7,5

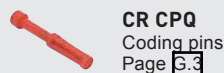
Wire diameter: up to 4,7 mm.

For basic or high thickness gold plating, please refer to page [F.13](#).

It is recommended to use the crimping tools and removal tools homologated by ILME (please see page [F.23](#))

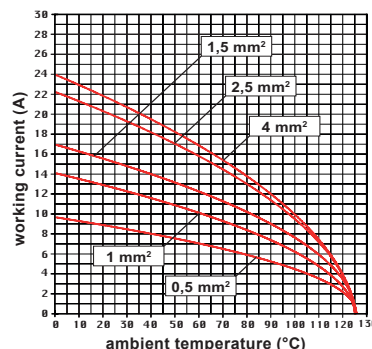
Materials

Insert	polycarbonate (PC)
UL 94 flame rating	V-0
Colour	pebble grey, RAL 7032
Contacts	copper alloy, silver ● and gold ● plated



Enclosures size 66.16

Heavy-Duty Applications	Pages
Metallic with IL-BRID lever	E.16-17
Metallic with JEI®-P lever	E.19
Metallic with Rigid IP67 lever	E.27
Aggressive Environments	
Metallic W-TYPE	E.30-31
Metallic E-Xtreme®	E.36-37
Specialized Applications	
EMC (Electromagnetic Shielding)	E.42-43
COB system for switch cabinet	E.29C



CDC 16 inserts max. current load derating diagram

CDC 16 + CDC 16 N

16 A 250 V

size **66.40**

32 poles +

Crimp connection

EN 61984 rating	16 A 250 V 4 kV 3
	16 A 230 / 400 V 4 kV 2
Rated voltage (UL / CSA)	600 V
Insulation resistance	≥ 10 GΩ
Contact resistance	≤ 1 mΩ
Ambient temperature limit	-40 °C ... +125 °C
Mechanical life (cycles)	≥ 500



ILME® ECBT2.E115072 | ECBT8.E115072

Item	Description	Part No.	Dimension
	Male inserts, No. (1-16) Male inserts, No. (17-32) Without contacts (to be ordered separately)	CDCM 16 CDCM 16 N	
	Female inserts, No. (1-16) Female inserts, No. (17-32) Without contacts (to be ordered separately)	CDCF 16 CDCF 16 N	

16 A advanced opening contacts		Male	Female	
section (mm ²)	section (AWG)			
0,5	20	CC 0.5 AN		
0,75	18	CC 0.7 AN		
1	18	CC 1.0 AN		
1,5	16	CC 1.5 AN		
2,5	14	CC 2.5 AN		
16 A crimp contacts				
section (mm ²)	section (AWG)			
0,14-0,37	26-22	CCMA 0.3	CCFA 0.3	
0,5	20	CCMA 0.5	CCFA 0.5	
0,75	18	CCMA 0.7	CCFA 0.7	
1	18	CCMA 1.0	CCFA 1.0	
1,5	16	CCMA 1.5	CCFA 1.5	
2,5	14	CCMA 2.5	CCFA 2.5	
3	12	CCMA 3.0	CCFA 3.0	
4	12	CCMA 4.0	CCFA 4.0	
0,14-0,37	26-22	CCMD 0.3	CCFD 0.3	
0,5	20	CCMD 0.5	CCFD 0.5	
0,75	18	CCMD 0.7	CCFD 0.7	
1	18	CCMD 1.0	CCFD 1.0	
1,5	16	CCMD 1.5	CCFD 1.5	
2,5	14	CCMD 2.5	CCFD 2.5	
3	12	CCMD 3.0	CCFD 3.0	
4	12	CCMD 4.0	CCFD 4.0	

Wiring information, CC contacts

conductor section (mm ²)	conductor slot ø A (mm)	stripping length (mm)
0,14-0,37	0,9	7,5
0,5	1,1	7,5
0,75	1,3	7,5
1,0	1,45	7,5
1,5	1,8	7,5
2,5	2,2	7,5
3,0	2,55	7,5
4,0	2,85	7,5

Wire diameter: up to 4,7 mm.

For basic or high thickness gold plating, please refer to page [F.13](#).

It is recommended to use the crimping tools and removal tools homologated by ILME (please see page [F.23](#))

Materials

Insert	polycarbonate (PC)
UL 94 flame rating	V-0
Colour	pebble grey, RAL 7032
Contacts	copper alloy, silver and gold plated

CR CPQ
Coding pins
Page [3.3](#)

Enclosures size 66.40

Pages [10](#)

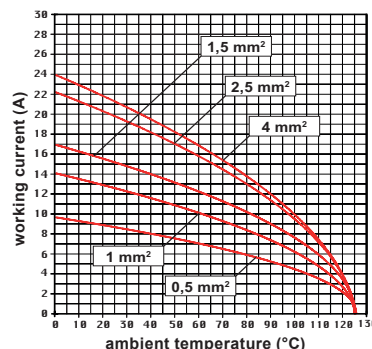
Heavy-Duty Applications

Metallic with C-TYPE lever [E.20-25](#)

Aggressive Environments

Metallic W-TYPE with C-TYPE lever [E.32-33](#)

Metallic E-Xtreme® with C-TYPE lever [E.38-39](#)



CDC 16 inserts max. current load derating diagram

CSAH-SQUICH® series

Connection without tools. Slim version.



CSAH series overview

The CSAH insert series features the SQUICH® technology to wire the connector, which is adaptable to any solid or flexible conductor, including unprepared conductors.

Each terminal has an **actuator button** that, when pressed, triggers the closure of a metallic spring, safely and reliably connecting the conductor to its respective electric contact in the connector.

The insert is supplied in the “open terminal” position, with each button raised and ready to be pressed:

Just Push!

No need for a tool to activate the terminal with a simple and easy wiring assembly.

SUM-UP

- › **Reduced space**
- › **Reduced wiring time**
- › **No need for tools**
- › **Quick identification of wired and non-wired terminals**
- › **Terminals already open and ready for conductor clamping**
- › **Built-in silver plated contacts**
- › **Excellent fastening solution**
- › **Great resistance to strong vibrations**



Watch our clip

FOCUS

Inserts' technology

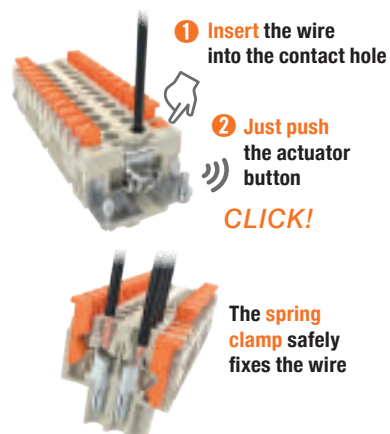
> Shaped button for terminal probing

The profile of the button used in the SQUICH® inserts allows a measuring probe to be inserted to verify the correct wiring or an electrical measurement.



TECHNOLOGY
AT A GLANCE

 **SQUICH®**



CSAH 10

16 A 250 Vsize **49.16****10 poles + ⊕****Tool-less connection – SQUICH®**

EN 61984 rating	16 A 250 V 4 kV 3
	16 A 400 V 4 kV 2
Rated voltage (UL / CSA)	600 V
Insulation resistance	≥ 10 GΩ
Contact resistance	≤ 3 mΩ
Ambient temperature limit	-40 °C ... +125 °C
Mechanical life (cycles)	≥ 500

CE UK EAC

CCC DNV VERITAS

CIRIUS ECBT2.E115072 | ECBT8.E115072

Item	Description	Part No.	Dimension
	Male inserts with male contacts Spring clamp connections, with actuator button	CSAHM 10	
	Female inserts with female contacts Spring clamp connections, with actuator button	CSAHF 10	

Materials

Insert	polycarbonate (PC)
UL 94 flame rating	V-0
Colour	pebble grey, RAL 7032
Contacts	built-in, copper alloy, silver ● plated

Wiring information

Wires cross sectional area	
- unprepared	0,14 mm ² - 2,5 mm ² (AWG 26-14)
- prepared	up to 1,5 mm ² (AWG 16)
Stripping length	9...11 mm

Enclosures size 49.16**Pages****Heavy-Duty Applications**

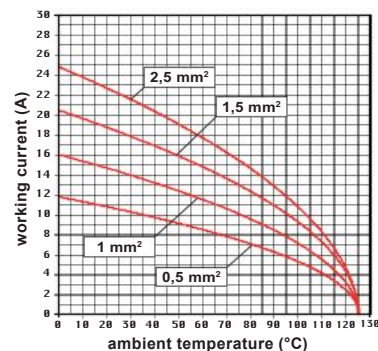
Metallic with IL-BRID lever	E.14-15
Metallic with JEI®-P lever	E.18
Metallic with Rigid IP67 lever	E.26

Aggressive Environments

Metallic W-TYPE	E.28-29
Metallic E-Xtreme®	E.34-35

Specialized Applications

EMC (Electromagnetic Shielding)	E.40-41
COB system for switch cabinet	E.290

**CSAH 10 inserts max. current load derating diagram**

CSAH 16

16 A 250 V

size **66.16**

16 poles +

Tool-less connection – SQUICH®

EN 61984 rating	16 A 250 V 4 kV 3
	16 A 400 V 4 kV 2
Rated voltage (UL / CSA)	600 V
Insulation resistance	≥ 10 GΩ
Contact resistance	≤ 3 mΩ
Ambient temperature limit	-40 °C ... +125 °C
Mechanical life (cycles)	≥ 500

CE UK EAC



CAIUS ECBT2.E115072 | ECBT8.E115072

Item	Description	Part No.	Dimension
	Male inserts with male contacts Spring clamp connections, with actuator button	CSAHM 16	
	Female inserts with female contacts Spring clamp connections, with actuator button	CSAHF 16	

CSAH

B

Materials

Insert	polycarbonate (PC)
UL 94 flame rating	V-0
Colour	pebble grey, RAL 7032
Contacts	built-in, copper alloy, silver ● plated

Wiring information

Wires cross sectional area	
- unprepared	0,14 mm ² - 2,5 mm ² (AWG 26-14)
- prepared	up to 1,5 mm ² (AWG 16)
Stripping length	9...11 mm

Enclosures size 66.16

Pages

Heavy-Duty Applications

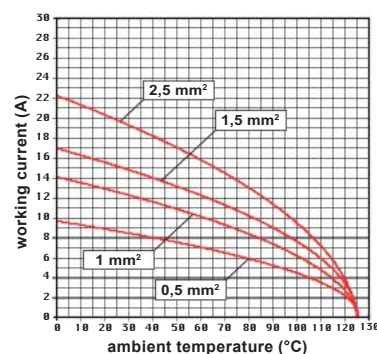
Metallic with IL-BRID lever	E.16-17
Metallic with JEI®-P lever	E.19
Metallic with Rigid IP67 lever	E.27

Aggressive Environments

Metallic W-TYPE	E.30-31
Metallic E-Xtreme®	E.36-37

Specialized Applications

EMC (Electromagnetic Shielding)	E.42-43
COB system for switch cabinet	E.290



CSAH 16 inserts max. current load derating diagram

CSAH 16 + CSAH 16 N

16 A 250 V

size **66.40**


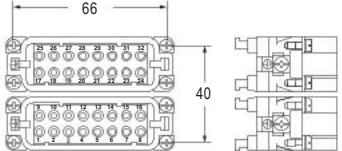

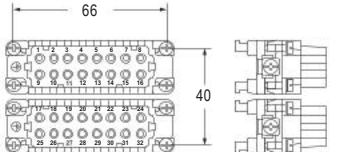
32 poles + ⊕

Tool-less connection – SQUICH®

EN 61984 rating	16 A 250 V 4 kV 3
	16 A 400 V 4 kV 2
Rated voltage (UL / CSA)	600 V
Insulation resistance	≥ 10 GΩ
Contact resistance	≤ 3 mΩ
Ambient temperature limit	-40 °C ... +125 °C
Mechanical life (cycles)	≥ 500



CEC® ECBT2.E115072 | ECBT8.E115072

Item	Description	Part No.	Dimension
	Male inserts, No. (1-16) Male inserts, No. (17-32) Spring clamp connections, with actuator button	CSAHM 16 CSAHM 16 N	
	Female inserts, No. (1-16) Female inserts, No. (17-32) Spring clamp connections, with actuator button	CSAHF 16 CSAHF 16 N	

CSAH


B

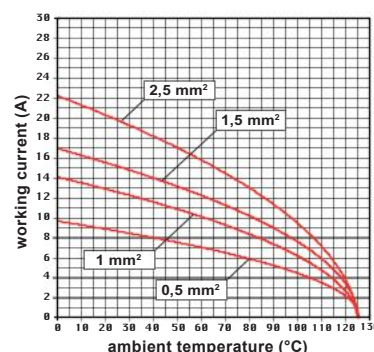
Materials

Insert	polycarbonate (PC)
UL 94 flame rating	V-0
Colour	pebble grey, RAL 7032
Contacts	built-in, copper alloy, silver ● plated

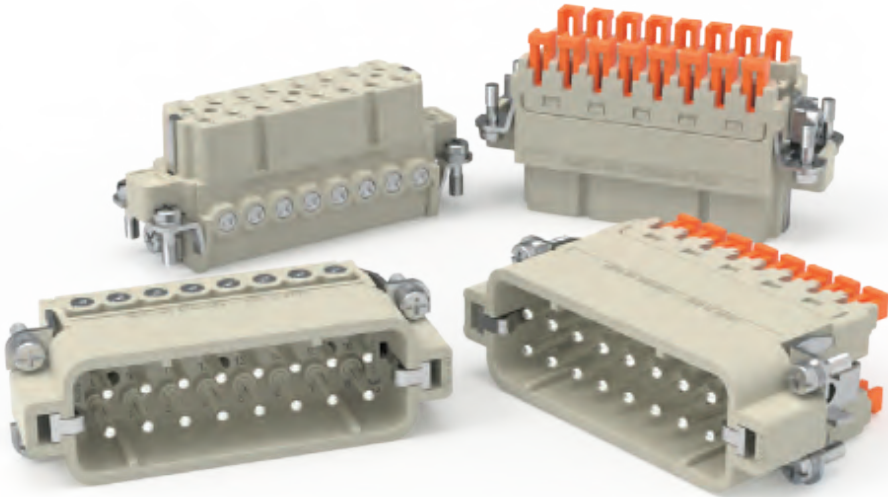
Wiring information

Wires cross sectional area	
- unprepared	0,14 mm ² - 2,5 mm ² (AWG 26-14)
- prepared	up to 1,5 mm ² (AWG 16)
Stripping length	9...11 mm

Enclosures size 66.40	Pages 
Heavy-Duty Applications	
Metallic with C-TYPE lever	E.20-29
Aggressive Environments	
Metallic W-TYPE with C-TYPE lever	E.32-33
Metallic E-Xtreme® with C-TYPE lever	E.38-39



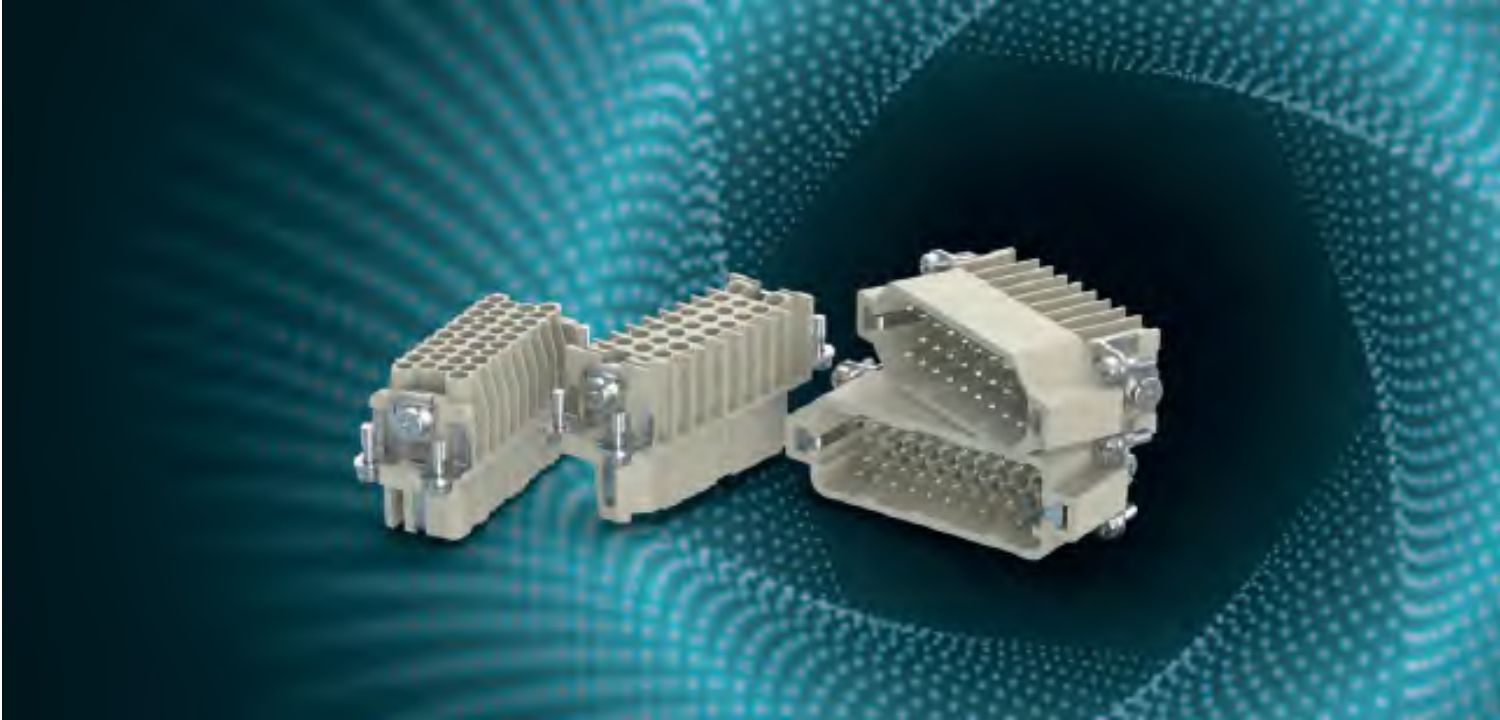
CSAH 16 inserts max. current load derating diagram



B

CD and CDD series

Slim sizes



CD and CDD series overview

The CD / CDD connector series has been designed for crimped connections made with removable crimp 10 A contacts, CD series.

Moreover, the CD 15 and CD 25 (together with CD 40 and CD 64, pages B.90-91) connectors are described in the EN 175301-801:2006 European standard, providing dimensional standardization for the insert geometry as well as for CD series crimp contacts and the main types (and sizes) of connector enclosures, including interface dimensions between the connector inserts and the relevant connector hood or housing, locking levers and pegs.

Single inserts versions

- > **CD 15** (15P + ⊕)
10 A 250 V 4kV 3 – size 49.16
- > **CDD 38** (38P + ⊕)
10 A 250 V 4kV 2 – high density – size 49.16
- > **CD 25** (25P + ⊕)
10 A 250 V 4kV 3 – size 66.16



Double inserts versions, side by side

- > **CD 25 + CD 25 Z** (50P + ⊕)
10 A 250 V 4kV 3 – size 66.40
- > **CDD 38 + CDD 38** (76P + ⊕)
10 A 250 V 4kV 2 – high density – size 66.40



FOCUS

Special voltages for CD series

As for any series of connector inserts for crimped connections, the polarity is intended as "up to", always possibly fitting a connector insert with a reduced number of crimped connections, suiting the specific application. In this regard, the CD series connector inserts can be used at specific (higher) voltages. If all the contacts are used, CD connector inserts may be used with voltage up to 250 V (first column) Pollution Degree 3 in accordance with EN 61984 standard.

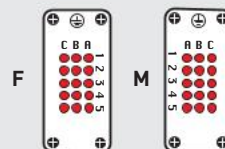
If the number of contacts is reduced and the contacts assigned accordingly, these connectors may be used at 500 V (second column) Pollution Degree 3.

This is possible because the decrease in the number of contacts leads to less restrictive clearances (insulating distances in air) and creepage distances (insulating distances along the surface).

- working contact
- without contact
- F female insert
- M male insert

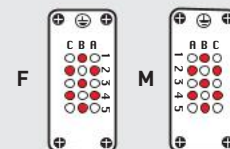
For use up to **250 V**
Pollution Degree 3

CD 15
15P + ⊕

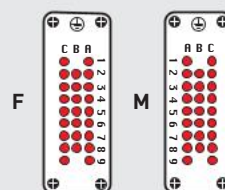


For use up to **500 V**
Pollution Degree 3

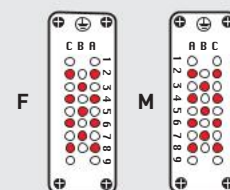
CD 15
7P + ⊕



CD 25
25P + ⊕



CD 25
11P + ⊕



contacts side - front view

CD 15

10 A 250 V


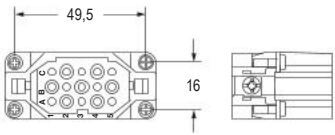
size **49.16**
15 poles + ⊕

Crimp connection

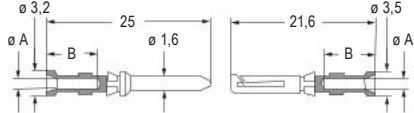




EN 61984 rating	10 A 250 V 4 kV 3
	10 A 230 / 400 V 4 kV 2
Rated voltage (UL / CSA)	600 V
Insulation resistance	≥ 10 GΩ
Contact resistance	≤ 3 mΩ
Ambient temperature limit	-40 °C ... +125 °C
Mechanical life (cycles)	≥ 500



ILME US ECBT2.E115072 | ECBT8.E115072

Item	Description	Part No.	Dimension
	Male inserts for male contacts Without contacts (to be ordered separately)	CDM 15	

	Female inserts for female contacts Without contacts (to be ordered separately)	CDF 15	
---	--	------------------------	---

10 A crimp contacts		Male	Female	
section (mm ²)	section (AWG)			
0,14-0,37	26-22			Wiring information, CD contacts
0,5	20	CDMA 0.3	CDFA 0.3	
0,75	18	CDMA 0.5	CDFA 0.5	
1	18	CDMA 0.7	CDFA 0.7	
1,5	16	CDMA 1.0	CDFA 1.0	
2,5	14	CDMA 1.5	CDFA 1.5	
		CDMA 2.5	CDFA 2.5	
0,14-0,37	26-22			
0,5	20	CDMD 0.3	CDFD 0.3	
0,75	18	CDMD 0.5	CDFD 0.5	
1	18	CDMD 0.7	CDFD 0.7	
1,5	16	CDMD 1.0	CDFD 1.0	
2,5	14	CDMD 1.5	CDFD 1.5	
		CDMD 2.5	CDFD 2.5	

Wiring information, CD contacts

conductor section (mm ²)	conductor slot ø A (mm)	stripping length B (mm)
0,14-0,37	0,9	8
0,5	1,1	8
0,75	1,3	8
1,0	1,45	8
1,5	1,8	8
2,5	2,2	6

Wire diameter: up to 3,8 mm.

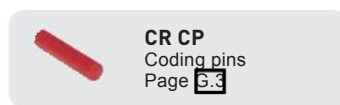
For basic or high thickness gold plating, please refer to page [E.16](#)

For stamped crimp contacts (SD series), please refer to page [E.18](#)

It is recommended to use the crimping tools and removal tools homologated by ILME (please see page [E.23](#))

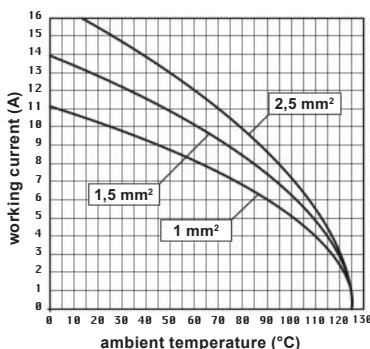
Materials

Insert	polycarbonate (PC)
UL 94 flame rating	V-0
Colour	pebble grey, RAL 7032
Contacts	copper alloy, silver ● and gold ● plated

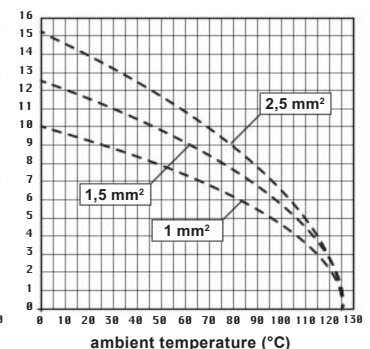


Enclosures size 49.16	Pages
Heavy-Duty Applications	
Metallic with IL-BRID lever	E.14-15
Metallic with JEI®-P lever	E.18
Metallic with Rigid IP67 lever	E.26
Aggressive Environments	
Metallic W-TYPE	E.28-29
Metallic E-Xtreme®	E.34-35
Specialized Applications	
EMC (Electromagnetic Shielding)	E.40-41
COB system for switch cabinet	E.29C

CD 15 inserts max. current load derating diagram, turned contacts



CD 15 inserts max. current load derating diagram, stamped contacts



For applications requiring higher voltages, please see the special voltage application section on page [E.23](#)

CD 25

10 A 250 V

size **66.16**
25 poles +

Crimp connection

EN 61984 rating	10 A 250 V 4 kV 3
	10 A 230 / 400 V 4 kV 2
Rated voltage (UL / CSA)	600 V
Insulation resistance	$\geq 10 \text{ G}\Omega$
Contact resistance	$\leq 3 \text{ m}\Omega$
Ambient temperature limit	-40 °C ... +125 °C
Mechanical life (cycles)	≥ 500

ECBT2.E115072 | ECBT8.E115072

Item	Description	Part No.	Dimension																													
	Male inserts for male contacts Without contacts (to be ordered separately)	CDM 25																														
	Female inserts for female contacts Without contacts (to be ordered separately)	CDF 25																														
	10 A crimp contacts section (mm ²) section (AWG) 0,14-0,37 26-22 0,5 20 0,75 18 1 18 1,5 16 2,5 14	<table border="0"> <tr> <td></td> <td>Male</td> <td>Female</td> </tr> <tr> <td rowspan="5" style="background-color: #cccccc; text-align: center; vertical-align: middle;">silver</td> <td>CDMA 0.3</td> <td>CDFA 0.3</td> </tr> <tr> <td>CDMA 0.5</td> <td>CDFA 0.5</td> </tr> <tr> <td>CDMA 0.7</td> <td>CDFA 0.7</td> </tr> <tr> <td>CDMA 1.0</td> <td>CDFA 1.0</td> </tr> <tr> <td>CDMA 1.5</td> <td>CDFA 1.5</td> </tr> <tr> <td>CDMA 2.5</td> <td>CDFA 2.5</td> </tr> <tr> <td rowspan="5" style="background-color: #ffff00; text-align: center; vertical-align: middle;">gold</td> <td>CDMD 0.3</td> <td>CDFD 0.3</td> </tr> <tr> <td>CDMD 0.5</td> <td>CDFD 0.5</td> </tr> <tr> <td>CDMD 0.7</td> <td>CDFD 0.7</td> </tr> <tr> <td>CDMD 1.0</td> <td>CDFD 1.0</td> </tr> <tr> <td>CDMD 1.5</td> <td>CDFD 1.5</td> </tr> <tr> <td>CDMD 2.5</td> <td>CDFD 2.5</td> </tr> </table>		Male	Female	silver	CDMA 0.3	CDFA 0.3	CDMA 0.5	CDFA 0.5	CDMA 0.7	CDFA 0.7	CDMA 1.0	CDFA 1.0	CDMA 1.5	CDFA 1.5	CDMA 2.5	CDFA 2.5	gold	CDMD 0.3	CDFD 0.3	CDMD 0.5	CDFD 0.5	CDMD 0.7	CDFD 0.7	CDMD 1.0	CDFD 1.0	CDMD 1.5	CDFD 1.5	CDMD 2.5	CDFD 2.5	
	Male	Female																														
silver	CDMA 0.3	CDFA 0.3																														
	CDMA 0.5	CDFA 0.5																														
	CDMA 0.7	CDFA 0.7																														
	CDMA 1.0	CDFA 1.0																														
	CDMA 1.5	CDFA 1.5																														
CDMA 2.5	CDFA 2.5																															
gold	CDMD 0.3	CDFD 0.3																														
	CDMD 0.5	CDFD 0.5																														
	CDMD 0.7	CDFD 0.7																														
	CDMD 1.0	CDFD 1.0																														
	CDMD 1.5	CDFD 1.5																														
CDMD 2.5	CDFD 2.5																															
			<p>Wiring information, CD contacts</p> <table border="1"> <thead> <tr> <th>conductor section (mm²)</th> <th>conductor slot ø A (mm)</th> <th>stripping length B (mm)</th> </tr> </thead> <tbody> <tr> <td>0,14-0,37</td> <td>0,9</td> <td>8</td> </tr> <tr> <td>0,5</td> <td>1,1</td> <td>8</td> </tr> <tr> <td>0,75</td> <td>1,3</td> <td>8</td> </tr> <tr> <td>1,0</td> <td>1,45</td> <td>8</td> </tr> <tr> <td>1,5</td> <td>1,8</td> <td>8</td> </tr> <tr> <td>2,5</td> <td>2,2</td> <td>6</td> </tr> </tbody> </table> <p>Wire diameter: up to 3,8 mm. For basic or high thickness gold plating, please refer to page E.16 For stamped crimp contacts (SD series), please refer to page E.18 It is recommended to use the crimping tools and removal tools homologated by ILME (please see page E.23)</p>	conductor section (mm ²)	conductor slot ø A (mm)	stripping length B (mm)	0,14-0,37	0,9	8	0,5	1,1	8	0,75	1,3	8	1,0	1,45	8	1,5	1,8	8	2,5	2,2	6								
conductor section (mm ²)	conductor slot ø A (mm)	stripping length B (mm)																														
0,14-0,37	0,9	8																														
0,5	1,1	8																														
0,75	1,3	8																														
1,0	1,45	8																														
1,5	1,8	8																														
2,5	2,2	6																														

Materials

Insert	polycarbonate (PC)
UL 94 flame rating	V-0
Colour	pebble grey, RAL 7032
Contacts	copper alloy, silver and gold plated



CR CP
Coding pins
Page [E.3](#)

Enclosures size 66.16

Pages

Heavy-Duty Applications

Metallic with IL-BRID lever	E.16-17
Metallic with JEI®-P lever	E.19
Metallic with Rigid IP67 lever	E.27

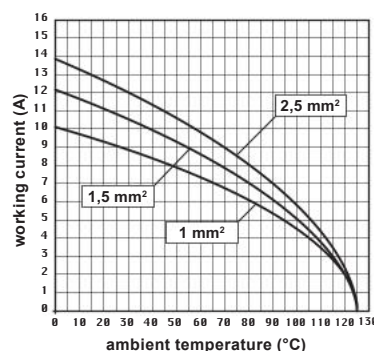
Aggressive Environments

Metallic W-TYPE	E.30-31
Metallic E-Xtreme®	E.36-37

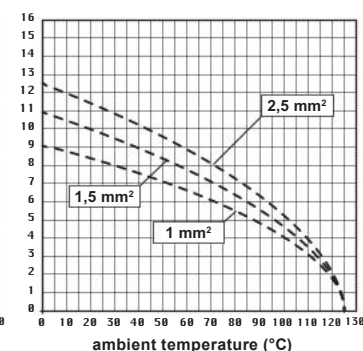
Specialized Applications

EMC (Electromagnetic Shielding)	E.42-43
COB system for switch cabinet	E.29C

CD 25 inserts max. current load derating diagram, turned contacts



CD 25 inserts max. current load derating diagram, stamped contacts



For applications requiring higher voltages, please see the special voltage application section on page [E.29](#)

CD 25 + CD 25 Z

10 A 250 V

size **66.40**


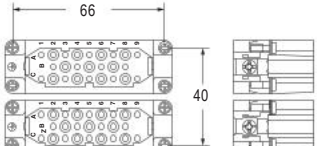
50 poles + ⊕


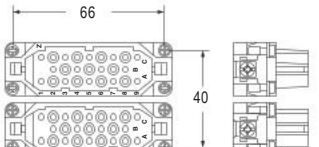
Crimp connection

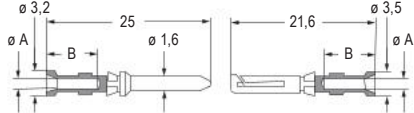


EN 61984 rating	10 A 250 V 4 kV 3
	10 A 230 / 400 V 4 kV 2
Rated voltage (UL / CSA)	600 V
Insulation resistance	≥ 10 GΩ
Contact resistance	≤ 3 mΩ
Ambient temperature limit	-40 °C ... +125 °C
Mechanical life (cycles)	≥ 500



ILME US ECBT2.E115072 | ECBT8.E115072

Item	Description	Part No.	Dimension
	Male inserts, No. (A1-C9)* Male inserts, No. (ZA1-ZC9)* Without contacts (to be ordered separately) * Coding compliant with Euromap recommendation	CDM 25 CDM 25 Z	

	Female inserts, No (A1-C9)* Female inserts, No. (ZA1-ZC9)* Without contacts (to be ordered separately) * Coding compliant with Euromap recommendation	CDF 25 CDF 25 Z	
---	---	--	---

10 A crimp contacts		Male	Female	
section (mm ²)	section (AWG)			
0,14-0,37	26-22	 CDMA 0.3	CDFA 0.3	
0,5	20	CDMA 0.5	CDFA 0.5	
0,75	18	CDMA 0.7	CDFA 0.7	
1	18	CDMA 1.0	CDFA 1.0	
1,5	16	CDMA 1.5	CDFA 1.5	
2,5	14	CDMA 2.5	CDFA 2.5	
0,14-0,37	26-22	 CDMD 0.3	CDFD 0.3	
0,5	20	CDMD 0.5	CDFD 0.5	
0,75	18	CDMD 0.7	CDFD 0.7	
1	18	CDMD 1.0	CDFD 1.0	
1,5	16	CDMD 1.5	CDFD 1.5	
2,5	14	CDMD 2.5	CDFD 2.5	


Wiring information, CD contacts

conductor section (mm ²)	conductor slot ø A (mm)	stripping length B (mm)
0,14-0,37	0,9	8
0,5	1,1	8
0,75	1,3	8
1,0	1,45	8
1,5	1,8	8
2,5	2,2	6

Wire diameter: up to 3,8 mm.
For basic or high thickness gold plating, please refer to page [E.16](#).
For stamped crimp contacts (SD series), please refer to page [E.18](#).
It is recommended to use the crimping tools and removal tools homologated by ILME (please see page [E.23](#)).

Materials

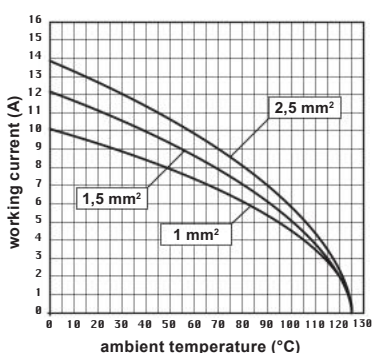
Insert	polycarbonate (PC)
UL 94 flame rating	V-0
Colour	pebble grey, RAL 7032
Contacts	copper alloy, silver ● and gold ● plated



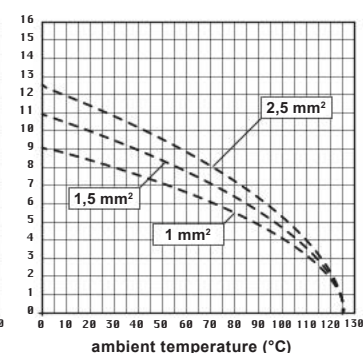
CR CP
Coding pins
Page [E.3](#)

Enclosures size 66.40	Pages
Heavy-Duty Applications	
Metallic with C-TYPE lever	E.20-25
Aggressive Environments	
Metallic W-TYPE with C-TYPE lever	E.32-33
Metallic E-Xtreme® with C-TYPE lever	E.38-39

CD 25 inserts max. current load derating diagram, turned contacts



CD 25 inserts max. current load derating diagram, stamped contacts



For applications requiring higher voltages, please see the special voltage application section on page [E.23](#)

CDD 38

10 A 250 V

size **66.16**

38 poles +

Crimp connection

EN 61984 rating	10 A 250 V 4 kV 2
Rated voltage (UL / CSA)	600 V
Insulation resistance	≥ 10 GΩ
Contact resistance	≤ 3 mΩ
Ambient temperature limit	-40 °C ... +125 °C
Mechanical life (cycles)	≥ 500



ILME ECBT2.E115072 | ECBT8.E115072

Item	Description	Part No.	Dimension
	Male inserts for male contacts Without contacts (to be ordered separately)	CDDM 38	

	Female inserts for female contacts Without contacts (to be ordered separately)	CDDF 38	
--	--	-------------------------	--

10 A crimp contacts	section (mm ²)		section (AWG)		Male	Female	
	0,14-0,37	0,5	0,75	1	1,5	2,5	
	0,14-0,37	0,5	0,75	1	1,5	2,5	
	26-22	20	18	18	16	14	
					silver		
					CDMA 0.3	CDFA 0.3	
					CDMA 0.5	CDFA 0.5	
					CDMA 0.7	CDFA 0.7	
					CDMA 1.0	CDFA 1.0	
					CDMA 1.5	CDFA 1.5	
					CDMA 2.5	CDFA 2.5	
					gold		
					CDMD 0.3	CDFD 0.3	
					CDMD 0.5	CDFD 0.5	
					CDMD 0.7	CDFD 0.7	
					CDMD 1.0	CDFD 1.0	
					CDMD 1.5	CDFD 1.5	
					CDMD 2.5	CDFD 2.5	

Wiring information, CD contacts

conductor section (mm ²)	conductor slot ø A (mm)	stripping length B (mm)
0,14-0,37	0,9	8
0,5	1,1	8
0,75	1,3	8
1,0	1,45	8
1,5	1,8	8
2,5	2,2	6

Wire diameter: up to 3,8 mm.

For basic or high thickness gold plating, please refer to page [E.16](#)

For stamped crimp contacts (SD series), please refer to page [E.18](#)

It is recommended to use the crimping tools and removal tools homologated by ILME (please see page [E.23](#))

Materials

Insert	polycarbonate (PC)
UL 94 flame rating	V-0
Colour	pebble grey, RAL 7032
Contacts	copper alloy, silver and gold plated

CR CP
Coding pins
Page [E.3](#)

Enclosures size 66.16

Heavy-Duty Applications

	Pages
Metallic with IL-BRID lever	E.16-17
Metallic with JEI®-P lever	E.19
Metallic with Rigid IP67 lever	E.27

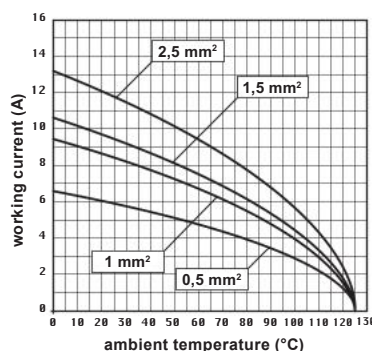
Aggressive Environments

Metallic W-TYPE	E.30-31
Metallic E-Xtreme®	E.36-37

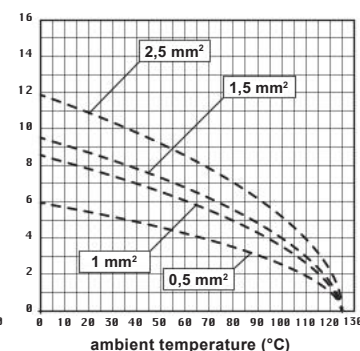
Specialized Applications

EMC (Electromagnetic Shielding)	E.42-43
COB system for switch cabinet	E.29C

CDD 38 inserts max. current load derating diagram, turned contacts



CDD 38 inserts max. current load derating diagram, stamped contacts



CDD 38 + CDD 38

10 A 250 V

size **66.40**


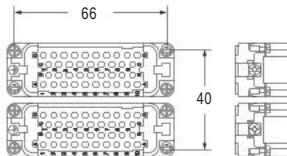
76 poles + ⊕


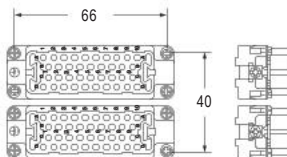
Crimp connection

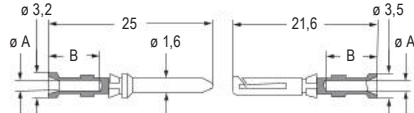


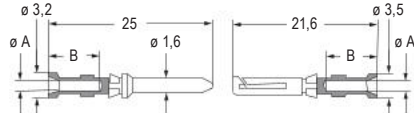


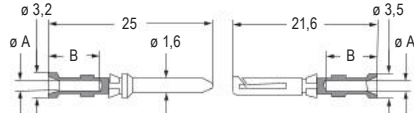
EN 61984 rating	10 A 250 V 4 kV 2
Rated voltage (UL / CSA)	600 V
Insulation resistance	≥ 10 GΩ
Contact resistance	≤ 3 mΩ
Ambient temperature limit	-40 °C ... +125 °C
Mechanical life (cycles)	≥ 500



CAIUS ECBT2.E115072 | ECBT8.E115072

Item	Description	Part No.	Dimension
	Male inserts for male contacts Without contacts (to be ordered separately)	CDDM 38 CDDM 38	

	Female inserts for female contacts Without contacts (to be ordered separately)	CDDF 38 CDDF 38	
---	--	--	---

10 A crimp contacts	section (mm ²)		section (AWG)		Male	Female		
	0,14-0,37	0,5	0,75	1	1,5	2,5		
	silver		CDMA 0.3	CDFA 0.3		CDMA 0.5	CDFA 0.5	
			CDMA 0.7	CDFA 0.7		CDMA 1.0	CDFA 1.0	
			CDMA 1.5	CDFA 1.5		CDMA 2.5	CDFA 2.5	
			CDMD 0.3	CDDF 0.3		CDMD 0.5	CDDF 0.5	
			CDMD 0.7	CDDF 0.7		CDMD 1.0	CDDF 1.0	
			CDMD 1.5	CDDF 1.5		CDMD 2.5	CDDF 2.5	
	gold		CDMD 0.3	CDDF 0.3		CDMD 0.5	CDDF 0.5	
			CDMD 0.7	CDDF 0.7		CDMD 1.0	CDDF 1.0	
			CDMD 1.5	CDDF 1.5		CDMD 2.5	CDDF 2.5	
			CDMD 0.3	CDDF 0.3		CDMD 0.5	CDDF 0.5	
			CDMD 0.7	CDDF 0.7		CDMD 1.0	CDDF 1.0	
			CDMD 1.5	CDDF 1.5		CDMD 2.5	CDDF 2.5	


Wiring information, CD contacts

conductor section (mm ²)	conductor slot ø A (mm)	stripping length B (mm)
0,14-0,37	0,9	8
0,5	1,1	8
0,75	1,3	8
1,0	1,45	8
1,5	1,8	8
2,5	2,2	6

Wire diameter: up to 3,8 mm.
For basic or high thickness gold plating, please refer to page [E.16](#).
For stamped crimp contacts (SD series), please refer to page [E.18](#).
It is recommended to use the crimping tools and removal tools homologated by ILME (please see page [E.23](#)).

Materials

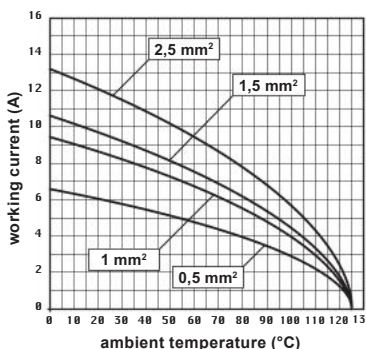
Insert	polycarbonate (PC)
UL 94 flame rating	V-0
Colour	pebble grey, RAL 7032
Contacts	copper alloy, silver ● and gold ● plated



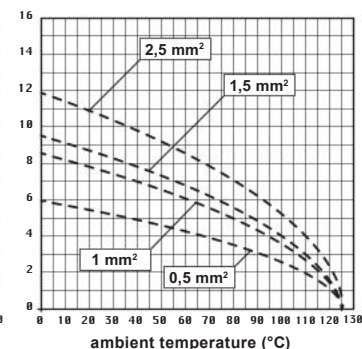
CR CP
Coding pins
Page [E.33](#)

Enclosures size 66.40	Pages
Heavy-Duty Applications	
Metallic with C-TYPE lever	E.20-28
Aggressive Environments	
Metallic W-TYPE with C-TYPE lever	E.32-33
Metallic E-Xtreme® with C-TYPE lever	E.38-39

CDD 38 inserts max. current load derating diagram, turned contacts



CDD 38 inserts max. current load derating diagram, stamped contacts





CNE and CCE series



The connector series presented in the following section have been designed after the experience of previously successful and technically proven multipole connection inserts.

The product range covers 16 nominal current-rated applications for up to 6, 10, 16, 24, 32 (2 × 16) and 48 (2 × 24) pole wiring options according to each connector dimension.

The **CNE** screw-type series and the **CCE** crimp series offer the possibility of choosing the preferred termination technology while saving cross-mating compatibility for each specific polarity.

CNE series overview

The connector features a cone-shaped terminal cavity to guide all stranded wires inside the terminal seat securely, stainless steel protection plate for the use of unprepared conductors, galvanized steel terminal screws and a rated voltage of 500 V.

CNE series features a **screw-type** connection technology requiring common and popular tools, like a 0,8 × 4 mm flat blade screwdriver or a Ph0 cross-headed screwdriver. Each terminal is presented completely open (unscrewed) and ready to be wired, reducing the assembly time. The connectors come in two main variants:

- > **with pressure (protection) plate** for unprepared conductors;
- > **without pressure (protection) plate** (suffix X), for prepared conductors (crimped with insulated or non-insulated wire ferrule of suitable size).

Use of prepared conductors is possible – although with no added value – also for CNE with pressure plate, but the highest conductor cross-sectional area 4 mm² / 12 AWG can be used only unprepared.

CCE series overview

The **CCE** series is the **evolution of the former CC series** for removable crimp contacts CC series, with a rated current of up to 16 A and a voltage rating of 500 V.

It shares the four (six with double inserts) mating interfaces with series: **CNE** (screw-type), **CSH** (spring-type with actuator button, SQUICH® technology), **CSS** (double spring-type), **CT** (screw-type with 45° terminal block), **CTSE** (spring-type with 45° terminal block).

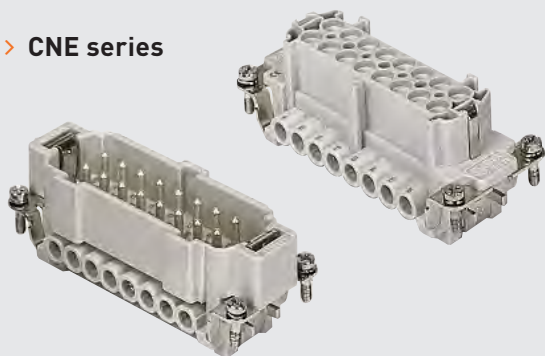
Whereas the CC series relied upon an additional stainless steel spring element to perform contact retention, the CCE series applies the modern and equally reliable concept of retention in the insulating body by a resilient element directly obtained in the contact holder.

Solid machined crimp contacts and the relevant connector inserts are the preferred option in fields of application subject to high vibration levels, such as railway rolling stock and everywhere transportation and moving parts are foreseen with, e.g. motors as potential sources of vibration.

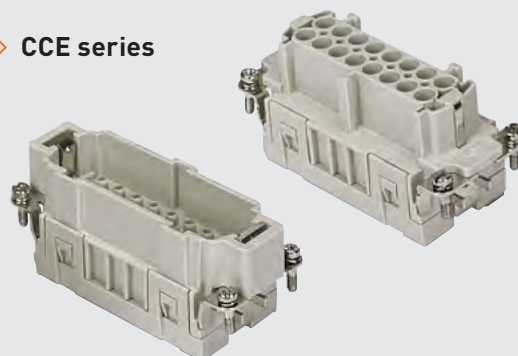
FOCUS

Inserts' technology

> CNE series



> CCE series



CNE 06 T

16 A 500 V

size **44.27**


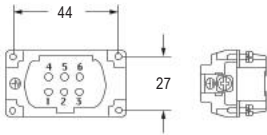

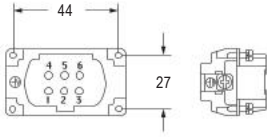

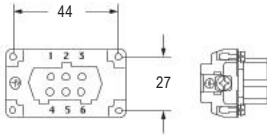

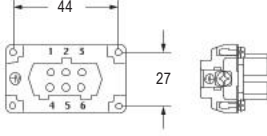
6 poles + ⊕

Screw connection

EN 61984 rating	16 A 500 V 6 kV 3
	16 A 400 / 690 V 6 kV 2
Rated voltage (UL / CSA)	600 V
Insulation resistance	≥ 10 GΩ
Contact resistance	≤ 1 mΩ
Ambient temperature limit	-40 °C ... +125 °C
Mechanical life (cycles)	≥ 500



ECBT2.E115072 | ECBT8.E115072
PVVA2.E506437 | PVVA8.E506437

Item	Description	Part No.	Dimension
	Male inserts with male contacts With pressure plate For unprepared conductors	CNE M06 T	
	Male inserts with male contacts Without pressure plate For prepared conductors	CNE M06 TX	
	Female inserts with female contacts With pressure plate For unprepared conductors	CNE F06 T	
	Female inserts with female contacts Without pressure plate For prepared conductors	CNE F06 TX	

Materials

Insert	polycarbonate (PC)
UL 94 flame rating	V-0
Colour	pebble grey, RAL 7032
Contacts	built-in, copper alloy, silver ● plated

Wiring information

Wires cross sectional area	
- unprepared	0,5 mm ² - 4 mm ² (AWG 20-12)
- prepared	0,25 mm ² - 2,5 mm ² (AWG 24-14)
Stripping length	7 mm
Terminal screw torque	0,5 Nm (4.4 lb.in)

> For unprepared conductors with pressure plate

> For prepared conductors without pressure plate



Enclosures size 44.27

Heavy-Duty Applications

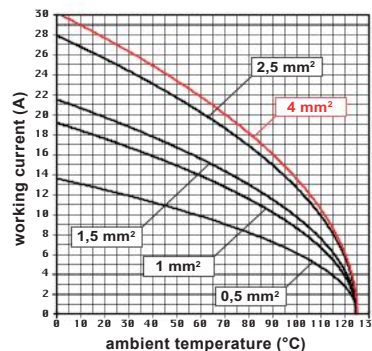
	Pages
Metallic with C-TYPE lever	E.48-53
Metallic with IL-BRID lever	E.90-91, 104
Metallic with JEI®-P lever	E.112, 119
Metallic with V-TYPE IP67 lever	E.124, 128-129
Thermoplastic T-TYPE	E.226-227, 234-235

Aggressive Environments

Metallic IP68 high protection	E.142-143
Metallic W-TYPE	E.154-155, 162
Metallic E-Xtreme®	E.174-175, 182-183, 194
Thermoplastic T-TYPE/W	E.226-227, 234-235

Specialized Applications

EMC (Electromagnetic Shielding)	E.208-209, 216
Hygienic series for food and beverage	E.244, 248
Standard applications with Central lever	E.254-255
BIG Enclosures for multiple cable entries	E.268, 272-273
COB system for switch cabinet	E.286-289
Light and Sound applications with JEI®-P lever	E.296-297



CNE 06 T inserts max. current load derating diagram

CNE 10 T**16 A 500 V**size **57.27****10 poles + ⊕****Screw connection**


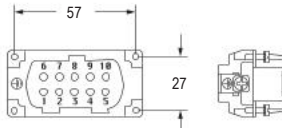

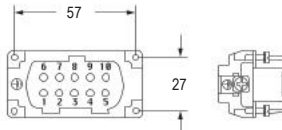

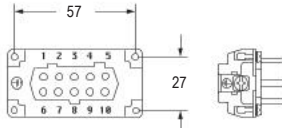

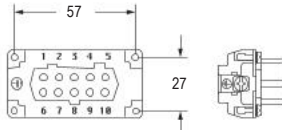
EN 61984 rating	16 A 500 V 6 kV 3
	16 A 400 / 690 V 6 kV 2
Rated voltage (UL / CSA)	600 V
Insulation resistance	≥ 10 GΩ
Contact resistance	≤ 1 mΩ
Ambient temperature limit	-40 °C ... +125 °C
Mechanical life (cycles)	≥ 500

CE UK EAC



CULUS

ECBT2.E115072 | ECBT8.E115072
PVVA2.E506437 | PVVA8.E506437

Item	Description	Part No.	Dimension
	Male inserts with male contacts With pressure plate For unprepared conductors	CNEM 10 T	
	Male inserts with male contacts Without pressure plate For prepared conductors	CNEM 10 TX	
	Female inserts with female contacts With pressure plate For unprepared conductors	CNEF 10 T	
	Female inserts with female contacts Without pressure plate For prepared conductors	CNEF 10 TX	

Materials

Insert	polycarbonate (PC)
UL 94 flame rating	V-0
Colour	pebble grey, RAL 7032
Contacts	built-in, copper alloy, silver ● plated

Wiring information

Wires cross sectional area	0,5 mm ² - 4 mm ² (AWG 20-12)
- unprepared	0,25 mm ² - 2,5 mm ² (AWG 24-14)
- prepared	7 mm
Stripping length	0,5 Nm (4.4 lb.in)
Terminal screw torque	

➤ For unprepared conductors
with pressure plate

➤ For prepared conductors
without pressure plate

**Enclosures size 57.27****Pages****Heavy-Duty Applications**

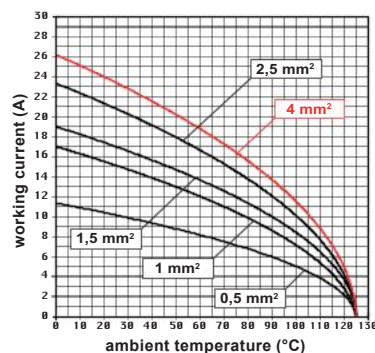
Metallic with C-TYPE lever	54-61
Metallic with IL-BRID lever	92-95, 105
Metallic with JEI®-P lever	113-114, 119
Metallic with V-TYPE IP67 lever	125, 130-131
Thermoplastic T-TYPE	228-229, 234-235

Aggressive Environments

Metallic IP68 high protection	144-145
Metallic W-TYPE	156-157, 163
Metallic E-Xtreme®	176-177, 184-185, 195
Thermoplastic T-TYPE/W	228-229, 234-235

Specialized Applications

EMC (Electromagnetic Shielding)	210-211, 217
Hygienic series for food and beverage	245, 248
Standard applications with Central lever	256-257
BIG Enclosures for multiple cable entries	269, 274-275
COB system for switch cabinet	286-289
Light and Sound applications with JEI®-P lever	298-299

**CNE 10 T inserts max. current load derating diagram**

CNE 16 T

16 A 500 V

size **77.27**

16 poles + ⊕

Screw connection

EN 61984 rating	16 A 500 V 6 kV 3
	16 A 400 / 690 V 6 kV 2
Rated voltage (UL / CSA)	600 V
Insulation resistance	≥ 10 GΩ
Contact resistance	≤ 1 mΩ
Ambient temperature limit	-40 °C ... +125 °C
Mechanical life (cycles)	≥ 500



ECBT2.E115072 | ECBT8.E115072
PVVA2.E506437 | PVVA8.E506437

Item	Description	Part No.	Dimension
	Male inserts with male contacts With pressure plate For unprepared conductors	CNEM 16 T	
	Male inserts with male contacts Without pressure plate For prepared conductors	CNEM 16 TX	
	Female inserts with female contacts With pressure plate For unprepared conductors	CNEF 16 T	
	Female inserts with female contacts Without pressure plate For prepared conductors	CNEF 16 TX	

Materials

Insert	polycarbonate (PC)
UL 94 flame rating	V-0
Colour	pebble grey, RAL 7032
Contacts	built-in, copper alloy, silver ● plated

Wiring information

Wires cross sectional area	
- unprepared	0,5 mm ² - 4 mm ² (AWG 20-12)
- prepared	0,25 mm ² - 2,5 mm ² (AWG 24-14)
Stripping length	7 mm
Terminal screw torque	0,5 Nm (4.4 lb.in)

> For unprepared conductors with pressure plate

> For prepared conductors without pressure plate



Enclosures size 77.27

Heavy-Duty Applications

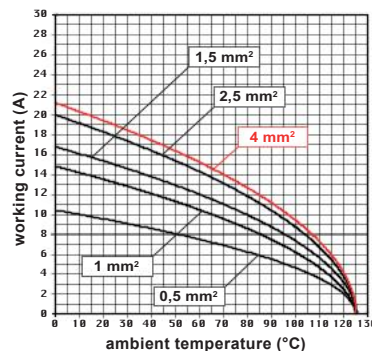
	Pages
Metallic with C-TYPE lever	E.62-69
Metallic with IL-BRID lever	E.96-99, 106
Metallic with JEI®-P lever	E.115-116, 119
Metallic with V-TYPE IP67 lever	E.126, 132-133
Thermoplastic T-TYPE	E.230-231, 234-235

Aggressive Environments

Metallic IP68 high protection	E.146-147
Metallic W-TYPE	E.158-159, 164
Metallic E-Xtreme®	E.178-179, 186-187, 196
Thermoplastic T-TYPE/W	E.230-231, 234-235

Specialized Applications

EMC (Electromagnetic Shielding)	E.212-213, 218
Hygienic series for food and beverage	E.246, 248
Standard applications with Central lever	E.258-259
BIG Enclosures for multiple cable entries	E.270, 276-277
COB system for switch cabinet	E.286-289
Light and Sound applications with JEI®-P lever	E.300-301



CNE 16 T inserts max. current load derating diagram

CNE 24 T

16 A 500 Vsize **104.27****24 poles + ⊕**


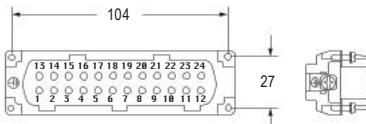

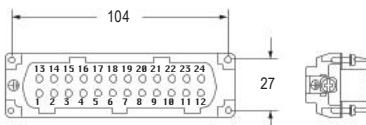

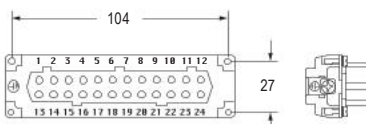

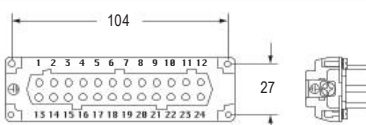
Screw connection

EN 61984 rating	16 A 500 V 6 kV 3
	16 A 400 / 690 V 6 kV 2
Rated voltage (UL / CSA)	600 V
Insulation resistance	≥ 10 GΩ
Contact resistance	≤ 1 mΩ
Ambient temperature limit	-40 °C ... +125 °C
Mechanical life (cycles)	≥ 500

CE UK EAC



ECBT2.E115072 | ECBT8.E115072
PVVA2.E506437 | PVVA8.E506437

Item	Description	Part No.	Dimension
	Male inserts with male contacts With pressure plate For unprepared conductors	CNEM 24 T	
	Male inserts with male contacts Without pressure plate For prepared conductors	CNEM 24 TX	
	Female inserts with female contacts With pressure plate For unprepared conductors	CNEF 24 T	
	Female inserts with female contacts Without pressure plate For prepared conductors	CNEF 24 TX	

Materials

Insert	polycarbonate (PC)
UL 94 flame rating	V-0
Colour	pebble grey, RAL 7032
Contacts	built-in, copper alloy, silver ● plated

Wiring information

Wires cross sectional area	0,5 mm ² - 4 mm ² (AWG 20-12)
- unprepared	0,25 mm ² - 2,5 mm ² (AWG 24-14)
- prepared	7 mm
Stripping length	0,5 Nm (4.4 lb.in)
Terminal screw torque	

➤ For unprepared conductors
with pressure plate

➤ For prepared conductors
without pressure plate



Enclosures size 104.27

Pages

Heavy-Duty Applications

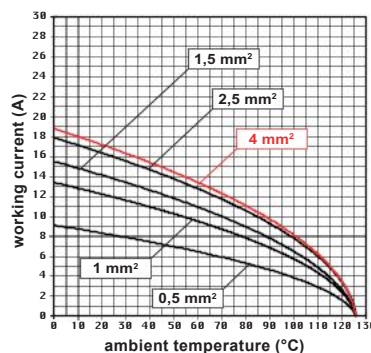
Metallic with C-TYPE lever	≡.70-77
Metallic with IL-BRID lever	≡.100-103 107
Metallic with JEI®-P lever	≡.117-119
Metallic with V-TYPE IP67 lever	≡.127 134-135
Thermoplastic T-TYPE	≡.232-235

Aggressive Environments

Metallic IP68 high protection	≡.148-149
Metallic W-TYPE	≡.160-161 165
Metallic E-Xtreme®	≡.180-181 188-189 197
Thermoplastic T-TYPE/W	≡.232-235

Specialized Applications

EMC (Electromagnetic Shielding)	≡.214-215 219
Hygienic series for food and beverage	≡.247-248
Standard applications with Central lever	≡.260-261
BIG Enclosures for multiple cable entries	≡.271 278-279
COB system for switch cabinet	≡.286-289
Light and Sound applications with JEI®-P lever	≡.302-303



CNE 24 T inserts max. current
load derating diagram

CNE 16 T + CNE 16 TN

16 A 500 V

size **77.62**

32 poles + ⊕

Screw connection

EN 61984 rating	16 A 500 V 6 kV 3
	16 A 400 / 690 V 6 kV 2
Rated voltage (UL / CSA)	600 V
Insulation resistance	≥ 10 GΩ
Contact resistance	≤ 1 mΩ
Ambient temperature limit	-40 °C ... +125 °C
Mechanical life (cycles)	≥ 500



ECB2.E115072 | ECBT8.E115072
PVVA2.E506437 | PVVA8.E506437

Item	Description	Part No.	Dimension
	Male inserts, No. (1-16) Male inserts, No. (17-32) With pressure plate For unprepared conductors	CNEM 16 T CNEM 16 TN	
	Male inserts, No. (1-16) Male inserts, No. (17-32) Without pressure plate For prepared conductors	CNEM 16 TX CNEM 16 TXN	
	Female inserts, No. (1-16) Female inserts, No. (17-32) With pressure plate For unprepared conductors	CNEF 16 T CNEF 16 TN	
	Female inserts, No. (1-16) Female inserts, No. (17-32) Without pressure plate For prepared conductors	CNEF 16 TX CNEF 16 TXN	

Materials

Insert	polycarbonate (PC)
UL 94 flame rating	V-0
Colour	pebble grey, RAL 7032
Contacts	built-in, copper alloy, silver ● plated

Wiring information

Wires cross sectional area	
- unprepared	0,5 mm ² - 4 mm ² (AWG 20-12)
- prepared	0,25 mm ² - 2,5 mm ² (AWG 24-14)
Stripping length	7 mm
Terminal screw torque	0,5 Nm (4.4 lb.in)

> For unprepared conductors with pressure plate

> For prepared conductors without pressure plate



Enclosures size 77.62

Pages

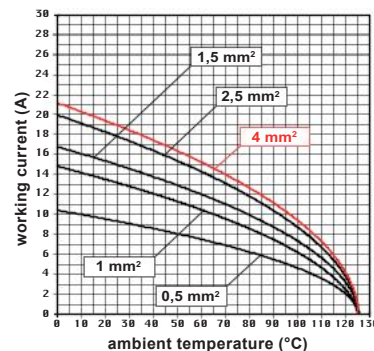
Heavy-Duty Applications

Metallic with C-TYPE lever **E.78-83**

Aggressive Environments

Metallic W-TYPE with C-TYPE lever **E.166-167**

Metallic E-Xtreme® with C-TYPE lever **E.190-191**



CNE 16 T inserts max. current load derating diagram



CNE 24 T + CNE 24 TN

16 A 500 V

size **104.62**

48 poles + ⊕

Screw connection

EN 61984 rating	16 A 500 V 6 kV 3
	16 A 400 / 690 V 6 kV 2
Rated voltage (UL / CSA)	600 V
Insulation resistance	≥ 10 GΩ
Contact resistance	≤ 1 mΩ
Ambient temperature limit	-40 °C ... +125 °C
Mechanical life (cycles)	≥ 500



ECBT2.E115072 | ECBT8.E115072
PVVA2.E506437 | PVVA8.E506437

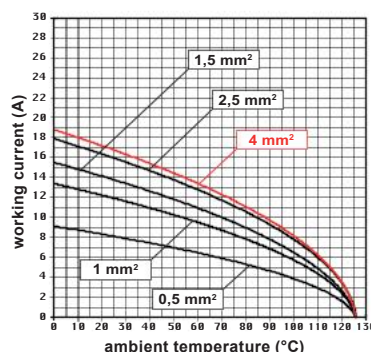
Item	Description	Part No.	Dimension
	Male inserts, No. (1-24) Male inserts, No. (25-48) With pressure plate For unprepared conductors	CNEM 24 T CNEM 24 TN	
	Male inserts, No. (1-24) Male inserts, No. (25-48) Without pressure plate For prepared conductors	CNEM 24 TX CNEM 24 TXN	
	Female inserts, No. (1-24) Female inserts, No. (25-48) With pressure plate For unprepared conductors	CNEF 24 T CNEF 24 TN	
	Female inserts, No. (1-24) Female inserts, No. (25-48) Without pressure plate For prepared conductors	CNEF 24 TX CNEF 24 TXN	

Materials	
Insert	polycarbonate (PC)
UL 94 flame rating	V-0
Colour	pebble grey, RAL 7032
Contacts	built-in, copper alloy, silver ● plated

Wiring information	
Wires cross sectional area	
- unprepared	0,5 mm ² - 4 mm ² (AWG 20-12)
- prepared	0,25 mm ² - 2,5 mm ² (AWG 24-14)
Stripping length	7 mm
Terminal screw torque	0,5 Nm (4.4 lb.in)



Enclosures size 104.62	Pages
Heavy-Duty Applications	
Metallic with C-TYPE lever	E.84-85
Aggressive Environments	
Metallic W-TYPE with C-TYPE lever	E.168-169
Metallic E-Xtreme® with C-TYPE lever	E.192-193



CNE 24 T inserts max. current load derating diagram

CCE 06

16 A 500 V

size **44.27**
6 poles + ⊕

Crimp connection

EN 61984 rating	16 A 500 V 6 kV 3
	16 A 400 / 690 V 6 kV 2
Rated voltage (UL / CSA)	600 V
Insulation resistance	≥ 10 GΩ
Contact resistance	≤ 1 mΩ
Ambient temperature limit	-40 °C ... +125 °C
Mechanical life (cycles)	≥ 500



ECB2.E115072 | ECBT8.E115072
PVVA2.E506437 | PVVA8.E506437

Item	Description	Part No.	Dimension
	Male inserts for male contacts Without contacts (to be ordered separately)	CCEM 06	

	Female inserts for female contacts Without contacts (to be ordered separately)	CCEF 06	
--	--	-------------------------	--

	16 A advanced opening contacts	Male	Female	
	section (mm ²) section (AWG) 0,5 20 0,75 18 1 18 1,5 16 2,5 14	CC 0.5 AN CC 0.7 AN CC 1.0 AN CC 1.5 AN CC 2.5 AN		
	16 A crimp contacts section (mm ²) section (AWG) 0,14-0,37 26-22 0,5 20 0,75 18 1 18 1,5 16 2,5 14 3 12 4 12	CCMA 0.3 CCMA 0.5 CCMA 0.7 CCMA 1.0 CCMA 1.5 CCMA 2.5 CCMA 3.0 CCMA 4.0	CCFA 0.3 CCFA 0.5 CCFA 0.7 CCFA 1.0 CCFA 1.5 CCFA 2.5 CCFA 3.0 CCFA 4.0	
	0,14-0,37 26-22 0,5 20 0,75 18 1 18 1,5 16 2,5 14 3 12 4 12	CCMD 0.3 CCMD 0.5 CCMD 0.7 CCMD 1.0 CCMD 1.5 CCMD 2.5 CCMD 3.0 CCMD 4.0	CCFD 0.3 CCFD 0.5 CCFD 0.7 CCFD 1.0 CCFD 1.5 CCFD 2.5 CCFD 3.0 CCFD 4.0	

Wiring information, CC contacts

conductor section (mm ²)	conductor slot ø A (mm)	stripping length (mm)
0,14-0,37	0,9	7,5
0,5	1,1	7,5
0,75	1,3	7,5
1,0	1,45	7,5
1,5	1,8	7,5
2,5	2,2	7,5
3,0	2,55	7,5
4,0	2,85	7,5

Wire diameter: up to 4,7 mm.

For basic or high thickness gold plating, please refer to page [E.13](#)

It is recommended to use the crimping tools and removal tools homologated by ILME (please see page [E.23](#))

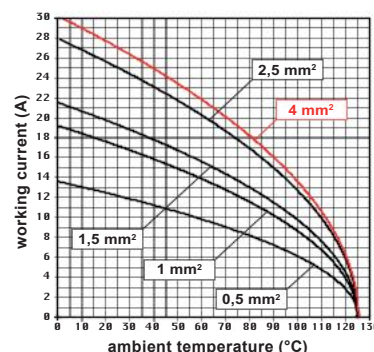
Materials

Insert	polycarbonate (PC)
UL 94 flame rating	V-0
Colour	pebble grey, RAL 7032
Contacts	copper alloy, silver ● and gold ● plated

CR CPQ
Coding pins
Page [E.3](#)

Enclosures size 44.27

Heavy-Duty Applications	Pages
Metallic with C-TYPE lever	E.48-53
Metallic with IL-BRID lever	E.90-91 , 104
Metallic with JEI®-P lever	E.112 , 119
Metallic with V-TYPE IP67 lever	E.124 , 128-129
Thermoplastic T-TYPE	E.226-227 , 234-235
Aggressive Environments	
Metallic IP68 high protection	E.142-143
Metallic W-TYPE	E.154-155 , 162
Metallic E-Xtreme®	E.174-175 , 182-183 , 194
Thermoplastic T-TYPE/W	E.226-227 , 234-235
Specialized Applications	
EMC (Electromagnetic Shielding)	E.208-209 , 216
Hygienic series for food and beverage	E.244 , 248
Standard applications with Central lever	E.254-255
BIG Enclosures for multiple cable entries	E.268 , 272-273
COB system for switch cabinet	E.286-289
Light and Sound applications with JEI®-P lever	E.296-297



CCE 06 inserts max. current load derating diagram

CCE 10

16 A 500 V

size **57.27**

10 poles + ⊕

Crimp connection

EN 61984 rating	16 A 500 V 6 kV 3
	16 A 400 / 690 V 6 kV 2
Rated voltage (UL / CSA)	600 V
Insulation resistance	≥ 10 GΩ
Contact resistance	≤ 1 mΩ
Ambient temperature limit	-40 °C ... +125 °C
Mechanical life (cycles)	≥ 500



ECBT2.E115072 | ECBT8.E115072
PVVA2.E506437 | PVVA8.E506437

Item	Description	Part No.	Dimension
	Male inserts for male contacts Without contacts (to be ordered separately)	CCEM 10	

	Female inserts for female contacts Without contacts (to be ordered separately)	CCEF 10	
--	--	-------------------------	--

	16 A advanced opening contacts	Male	Female	
	section (mm ²) section (AWG)			
	0,5 20	CC 0.5 AN		
	0,75 18	CC 0.7 AN		
	1 18	CC 1.0 AN		
	1,5 16	CC 1.5 AN		
	2,5 14	CC 2.5 AN		
	16 A crimp contacts			
	section (mm ²) section (AWG)			
	0,14-0,37 26-22	CCMA 0.3	CCFA 0.3	
	0,5 20	CCMA 0.5	CCFA 0.5	
	0,75 18	CCMA 0.7	CCFA 0.7	
	1 18	CCMA 1.0	CCFA 1.0	
	1,5 16	CCMA 1.5	CCFA 1.5	
	2,5 14	CCMA 2.5	CCFA 2.5	
	3 12	CCMA 3.0	CCFA 3.0	
	4 12	CCMA 4.0	CCFA 4.0	
	0,14-0,37 26-22	CCMD 0.3	CCFD 0.3	
	0,5 20	CCMD 0.5	CCFD 0.5	
	0,75 18	CCMD 0.7	CCFD 0.7	
	1 18	CCMD 1.0	CCFD 1.0	
	1,5 16	CCMD 1.5	CCFD 1.5	
	2,5 14	CCMD 2.5	CCFD 2.5	
	3 12	CCMD 3.0	CCFD 3.0	
	4 12	CCMD 4.0	CCFD 4.0	

Wiring information, CC contacts

conductor section (mm ²)	conductor slot ø A (mm)	stripping length (mm)
0,14-0,37	0,9	7,5
0,5	1,1	7,5
0,75	1,3	7,5
1,0	1,45	7,5
1,5	1,8	7,5
2,5	2,2	7,5
3,0	2,55	7,5
4,0	2,85	7,5

Wire diameter: up to 4,7 mm.

For basic or high thickness gold plating, please refer to page [E.13](#).

It is recommended to use the crimping tools and removal tools homologated by ILME (please see page [E.23](#))

Materials

Insert	polycarbonate (PC)
UL 94 flame rating	V-0
Colour	pebble grey, RAL 7032
Contacts	copper alloy, silver ● and gold ● plated

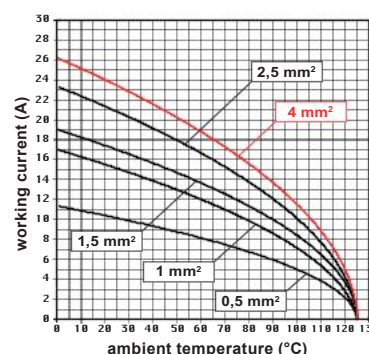
CR CPQ
Coding pins
Page [E.3](#)

Enclosures size 57.27

Pages

Applications	Pages
Heavy-Duty Applications	
Metallic with C-TYPE lever	E.54-61
Metallic with IL-BRID lever	E.92-95 E.105
Metallic with JEI®-P lever	E.113-114 E.119
Metallic with V-TYPE IP67 lever	E.125 E.130-131
Thermoplastic T-TYPE	E.228-229 E.234-235
Aggressive Environments	
Metallic IP68 high protection	E.144-145
Metallic W-TYPE	E.156-157 E.163
Metallic E-Xtreme®	E.176-177 E.184-185 E.195
Thermoplastic T-TYPE/W	E.228-229 E.234-235
Specialized Applications	
EMC (Electromagnetic Shielding)	E.210-211 E.217
Hygienic series for food and beverage	E.245 E.248
Standard applications with Central lever	E.256-257
BIG Enclosures for multiple cable entries	E.269 E.274-275
COB system for switch cabinet	E.286-289
Light and Sound applications with JEI®-P lever	E.298-299

CCE 10 inserts max. current load derating diagram



CCE 16

16 A 500 V

size **77.27**


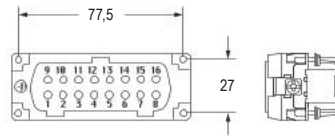
16 poles + ⊕


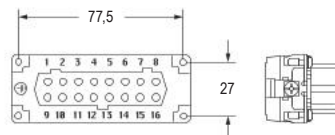
Crimp connection


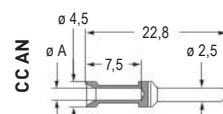

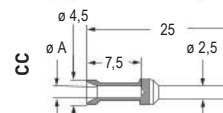

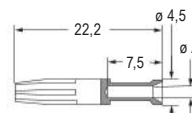
EN 61984 rating	16 A 500 V 6 kV 3
	16 A 400 / 690 V 6 kV 2
Rated voltage (UL / CSA)	600 V
Insulation resistance	≥ 10 GΩ
Contact resistance	≤ 1 mΩ
Ambient temperature limit	-40 °C ... +125 °C
Mechanical life (cycles)	≥ 500



ECBT2.E115072 | ECBT8.E115072
PVVA2.E506437 | PVVA8.E506437

Item	Description	Part No.	Dimension
	Male inserts for male contacts Without contacts (to be ordered separately)	CCEM 16	

	Female inserts for female contacts Without contacts (to be ordered separately)	CCEF 16	
---	--	-------------------------	---

	16 A advanced opening contacts	Male	Female	
	section (mm ²) section (AWG) 0,5 20 0,75 18 1 18 1,5 16 2,5 14	CC 0.5 AN CC 0.7 AN CC 1.0 AN CC 1.5 AN CC 2.5 AN		
	16 A crimp contacts section (mm ²) section (AWG) 0,14-0,37 26-22 0,5 20 0,75 18 1 18 1,5 16 2,5 14 3 12 4 12	CCMA 0.3 CCMA 0.5 CCMA 0.7 CCMA 1.0 CCMA 1.5 CCMA 2.5 CCMA 3.0 CCMA 4.0	CCFA 0.3 CCFA 0.5 CCFA 0.7 CCFA 1.0 CCFA 1.5 CCFA 2.5 CCFA 3.0 CCFA 4.0	
	0,14-0,37 26-22 0,5 20 0,75 18 1 18 1,5 16 2,5 14 3 12 4 12	CCMD 0.3 CCMD 0.5 CCMD 0.7 CCMD 1.0 CCMD 1.5 CCMD 2.5 CCMD 3.0 CCMD 4.0	CCFD 0.3 CCFD 0.5 CCFD 0.7 CCFD 1.0 CCFD 1.5 CCFD 2.5 CCFD 3.0 CCFD 4.0	

Wiring information, CC contacts

conductor section (mm ²)	conductor slot ø A (mm)	stripping length (mm)
0,14-0,37	0,9	7,5
0,5	1,1	7,5
0,75	1,3	7,5
1,0	1,45	7,5
1,5	1,8	7,5
2,5	2,2	7,5
3,0	2,55	7,5
4,0	2,85	7,5


Wire diameter: up to 4,7 mm.

For basic or high thickness gold plating, please refer to page [E.13](#)

It is recommended to use the crimping tools and removal tools homologated by ILME (please see page [E.23](#))

Materials

Insert	polycarbonate (PC)
UL 94 flame rating	V-0
Colour	pebble grey, RAL 7032
Contacts	copper alloy, silver ● and gold ● plated



CR CPQ
Coding pins
Page [E.3](#)

Enclosures size 77.27

Heavy-Duty Applications	Pages
Metallic with C-TYPE lever	E.62-69
Metallic with IL-BRID lever	E.96-99 , 106
Metallic with JEI®-P lever	E.115-116 , 119
Metallic with V-TYPE IP67 lever	E.126 , 132-133
Thermoplastic T-TYPE	E.230-231 , 234-235

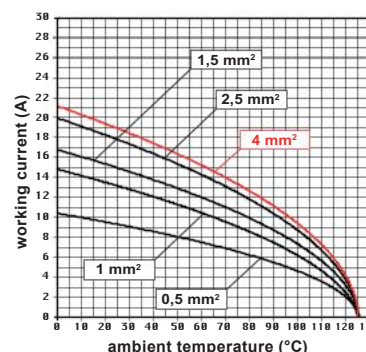
Aggressive Environments

Metallic IP68 high protection	E.146-147
Metallic W-TYPE	E.158-159 , 164
Metallic E-Xtreme®	E.178-179 , 186-187 , 196
Thermoplastic T-TYPE/W	E.230-231 , 234-235

Specialized Applications

EMC (Electromagnetic Shielding)	E.212-213 , 218
Hygienic series for food and beverage	E.246 , 248
Standard applications with Central lever	E.258-259
BIG Enclosures for multiple cable entries	E.270 , 276-277
COB system for switch cabinet	E.286-289
Light and Sound applications with JEI®-P lever	E.300-301

CCE 16 inserts max. current load derating diagram



CCE 24

16 A 500 V

size **104.27**

24 poles + ⊕

Crimp connection

EN 61984 rating	16 A 500 V 6 kV 3
	16 A 400 / 690 V 6 kV 2
Rated voltage (UL / CSA)	600 V
Insulation resistance	≥ 10 GΩ
Contact resistance	≤ 1 mΩ
Ambient temperature limit	-40 °C ... +125 °C
Mechanical life (cycles)	≥ 500



ECBT2.E115072 | ECBT8.E115072
PVVA2.E506437 | PVVA8.E506437

Item	Description	Part No.	Dimension
	Male inserts for male contacts Without contacts (to be ordered separately)	CCEM 24	

	Female inserts for female contacts Without contacts (to be ordered separately)	CCEF 24	
--	--	-------------------------	--

	16 A advanced opening contacts	Male	Female	
	section (mm ²) section (AWG)			
	0,5 20	CC 0.5 AN		
	0,75 18	CC 0.7 AN		
	1 18	CC 1.0 AN		
	1,5 16	CC 1.5 AN		
	2,5 14	CC 2.5 AN		
	16 A crimp contacts			
	section (mm ²) section (AWG)			
	0,14-0,37 26-22	CCMA 0.3	CCFA 0.3	
	0,5 20	CCMA 0.5	CCFA 0.5	
	0,75 18	CCMA 0.7	CCFA 0.7	
	1 18	CCMA 1.0	CCFA 1.0	
	1,5 16	CCMA 1.5	CCFA 1.5	
	2,5 14	CCMA 2.5	CCFA 2.5	
	3 12	CCMA 3.0	CCFA 3.0	
	4 12	CCMA 4.0	CCFA 4.0	
	0,14-0,37 26-22	CCMD 0.3	CCFD 0.3	
	0,5 20	CCMD 0.5	CCFD 0.5	
	0,75 18	CCMD 0.7	CCFD 0.7	
	1 18	CCMD 1.0	CCFD 1.0	
	1,5 16	CCMD 1.5	CCFD 1.5	
	2,5 14	CCMD 2.5	CCFD 2.5	
	3 12	CCMD 3.0	CCFD 3.0	
	4 12	CCMD 4.0	CCFD 4.0	

Wiring information, CC contacts

conductor section (mm ²)	conductor slot ø A (mm)	stripping length (mm)
0,14-0,37	0,9	7,5
0,5	1,1	7,5
0,75	1,3	7,5
1,0	1,45	7,5
1,5	1,8	7,5
2,5	2,2	7,5
3,0	2,55	7,5
4,0	2,85	7,5

Wire diameter: up to 4,7 mm.

For basic or high thickness gold plating, please refer to page [F.13](#).

It is recommended to use the crimping tools and removal tools homologated by ILME (please see page [F.23](#)).

Materials

Insert	polycarbonate (PC)
UL 94 flame rating	V-0
Colour	pebble grey, RAL 7032
Contacts	copper alloy, silver ● and gold ● plated

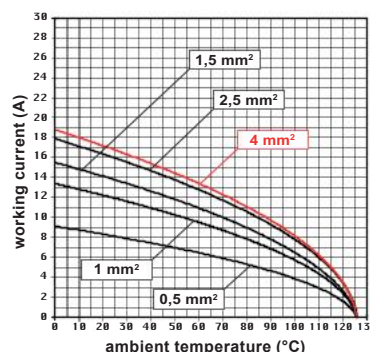
CR CPQ
Coding pins
Page [E.33](#)

Enclosures size 104.27

Pages

Heavy-Duty Applications	Pages
Metallic with C-TYPE lever	E.70-77
Metallic with IL-BRID lever	E.100-103 107
Metallic with JEI®-P lever	E.117-119
Metallic with V-TYPE IP67 lever	E.127 134-135
Thermoplastic T-TYPE	E.232-235
Aggressive Environments	
Metallic IP68 high protection	E.148-149
Metallic W-TYPE	E.160-161 165
Metallic E-Xtreme®	E.180-181 188-189 197
Thermoplastic T-TYPE/W	E.232-235
Specialized Applications	
EMC (Electromagnetic Shielding)	E.214-215 219
Hygienic series for food and beverage	E.247-248
Standard applications with Central lever	E.260-261
BIG Enclosures for multiple cable entries	E.271 278-279
COB system for switch cabinet	E.286-289
Light and Sound applications with JEI®-P lever	E.302-303

CCE 24 inserts max. current load derating diagram



CCE 16 + CCE 16 N

16 A 500 V

size **77.62**

32 poles +

Crimp connection

EN 61984 rating	16 A 500 V 6 kV 3
	16 A 400 / 690 V 6 kV 2
Rated voltage (UL / CSA)	600 V
Insulation resistance	≥ 10 GΩ
Contact resistance	≤ 1 mΩ
Ambient temperature limit	-40 °C ... +125 °C
Mechanical life (cycles)	≥ 500



ECB2.E115072 | ECBT8.E115072
PVVA2.E506437 | PVVA8.E506437

Item	Description	Part No.	Dimension
	Male inserts, No. (1-16) Male inserts, No. (17-32) Without contacts (to be ordered separately)	CCEM 16 CCEM 16 N	
	Female inserts, No. (1-16) Female inserts, No. (17-32) Without contacts (to be ordered separately)	CCEF 16 CCEF 16 N	

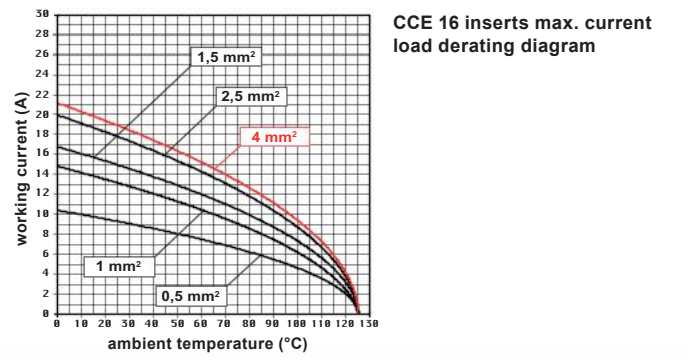
CCE
B

	16 A advanced opening contacts	Male	Female																												
	section (mm ²) section (AWG)			 Wiring information, CC contacts <table border="1"> <thead> <tr> <th>conductor section (mm²)</th> <th>conductor slot $\varnothing A$ (mm)</th> <th>stripping length (mm)</th> </tr> </thead> <tbody> <tr><td>0,14-0,37</td><td>0,9</td><td>7,5</td></tr> <tr><td>0,5</td><td>1,1</td><td>7,5</td></tr> <tr><td>0,75</td><td>1,3</td><td>7,5</td></tr> <tr><td>1,0</td><td>1,45</td><td>7,5</td></tr> <tr><td>1,5</td><td>1,8</td><td>7,5</td></tr> <tr><td>2,5</td><td>2,2</td><td>7,5</td></tr> <tr><td>3,0</td><td>2,55</td><td>7,5</td></tr> <tr><td>4,0</td><td>2,85</td><td>7,5</td></tr> </tbody> </table> <p>Wire diameter: up to 4,7 mm. For basic or high thickness gold plating, please refer to page E.13 It is recommended to use the crimping tools and removal tools homologated by ILME (please see page E.23)</p>	conductor section (mm ²)	conductor slot $\varnothing A$ (mm)	stripping length (mm)	0,14-0,37	0,9	7,5	0,5	1,1	7,5	0,75	1,3	7,5	1,0	1,45	7,5	1,5	1,8	7,5	2,5	2,2	7,5	3,0	2,55	7,5	4,0	2,85	7,5
conductor section (mm ²)	conductor slot $\varnothing A$ (mm)	stripping length (mm)																													
0,14-0,37	0,9	7,5																													
0,5	1,1	7,5																													
0,75	1,3	7,5																													
1,0	1,45	7,5																													
1,5	1,8	7,5																													
2,5	2,2	7,5																													
3,0	2,55	7,5																													
4,0	2,85	7,5																													
	0,5 20	CC 0.5 AN																													
	0,75 18	CC 0.7 AN																													
	1 18	CC 1.0 AN																													
	1,5 16	CC 1.5 AN																													
	2,5 14	CC 2.5 AN																													
	16 A crimp contacts			 																											
	section (mm ²) section (AWG)																														
	0,14-0,37 26-22	CCMA 0.3	CCFA 0.3																												
	0,5 20	CCMA 0.5	CCFA 0.5																												
	0,75 18	CCMA 0.7	CCFA 0.7																												
	1 18	CCMA 1.0	CCFA 1.0																												
	1,5 16	CCMA 1.5	CCFA 1.5																												
	2,5 14	CCMA 2.5	CCFA 2.5																												
	3 12	CCMA 3.0	CCFA 3.0																												
	4 12	CCMA 4.0	CCFA 4.0																												
	0,14-0,37 26-22	CCMD 0.3	CCFD 0.3																												
	0,5 20	CCMD 0.5	CCFD 0.5																												
	0,75 18	CCMD 0.7	CCFD 0.7																												
	1 18	CCMD 1.0	CCFD 1.0																												
	1,5 16	CCMD 1.5	CCFD 1.5																												
	2,5 14	CCMD 2.5	CCFD 2.5																												
	3 12	CCMD 3.0	CCFD 3.0																												
	4 12	CCMD 4.0	CCFD 4.0																												

Materials	
Insert	polycarbonate (PC)
UL 94 flame rating	V-0
Colour	pebble grey, RAL 7032
Contacts	copper alloy, silver and gold plated

CR CPQ
Coding pins
Page [E.3](#)

Enclosures size 77.62	Pages
Heavy-Duty Applications	
Metallic with C-TYPE lever	E.78-83
Aggressive Environments	
Metallic W-TYPE with C-TYPE lever	E.166-167
Metallic E-Xtreme® with C-TYPE lever	E.190-191



CCE 24 + CCE 24 N

16 A 500 V

size **104.62**

48 poles +

Crimp connection

EN 61984 rating	16 A 500 V 6 kV 3
	16 A 400 / 690 V 6 kV 2
Rated voltage (UL / CSA)	600 V
Insulation resistance	≥ 10 GΩ
Contact resistance	≤ 1 mΩ
Ambient temperature limit	-40 °C ... +125 °C
Mechanical life (cycles)	≥ 500



ECBT2.E115072 | ECBT8.E115072
PVVA2.E506437 | PVVA8.E506437

Item	Description	Part No.	Dimension
	Male inserts, No. (1-24) Male inserts, No. (25-48) Without contacts (to be ordered separately)	CCEM 24 CCEM 24 N	

	Female inserts, No. (1-24) Female inserts, No. (25-48) Without contacts (to be ordered separately)	CCEF 24 CCEF 24 N	
--	---	--	--

	16 A advanced opening contacts	Male	Female	
	section (mm ²) section (AWG) 0,5 20 0,75 18 1 18 1,5 16 2,5 14	CC 0.5 AN CC 0.7 AN CC 1.0 AN CC 1.5 AN CC 2.5 AN		
	16 A crimp contacts section (mm ²) section (AWG) 0,14-0,37 26-22 0,5 20 0,75 18 1 18 1,5 16 2,5 14 3 12 4 12	CCMA 0.3 CCMA 0.5 CCMA 0.7 CCMA 1.0 CCMA 1.5 CCMA 2.5 CCMA 3.0 CCMA 4.0	CCFA 0.3 CCFA 0.5 CCFA 0.7 CCFA 1.0 CCFA 1.5 CCFA 2.5 CCFA 3.0 CCFA 4.0	
	0,14-0,37 26-22 0,5 20 0,75 18 1 18 1,5 16 2,5 14 3 12 4 12	CCMD 0.3 CCMD 0.5 CCMD 0.7 CCMD 1.0 CCMD 1.5 CCMD 2.5 CCMD 3.0 CCMD 4.0	CCFD 0.3 CCFD 0.5 CCFD 0.7 CCFD 1.0 CCFD 1.5 CCFD 2.5 CCFD 3.0 CCFD 4.0	

Wiring information, CC contacts

conductor section (mm ²)	conductor slot ø A (mm)	stripping length (mm)
0,14-0,37	0,9	7,5
0,5	1,1	7,5
0,75	1,3	7,5
1,0	1,45	7,5
1,5	1,8	7,5
2,5	2,2	7,5
3,0	2,55	7,5
4,0	2,85	7,5

Wire diameter: up to 4,7 mm.

For basic or high thickness gold plating, please refer to page [E.13](#).

It is recommended to use the crimping tools and removal tools homologated by ILME (please see page [E.23](#))

Materials

Insert	polycarbonate (PC)
UL 94 flame rating	V-0
Colour	pebble grey, RAL 7032
Contacts	copper alloy, silver and gold plated

CR CPQ
Coding pins
Page [E.33](#)

Enclosures size 104.62

Pages [E.84-E.85](#)

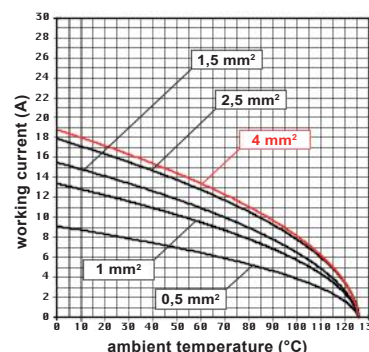
Heavy-Duty Applications

Metallic with C-TYPE lever [E.84-85](#)

Aggressive Environments

Metallic W-TYPE with C-TYPE lever [E.168-169](#)

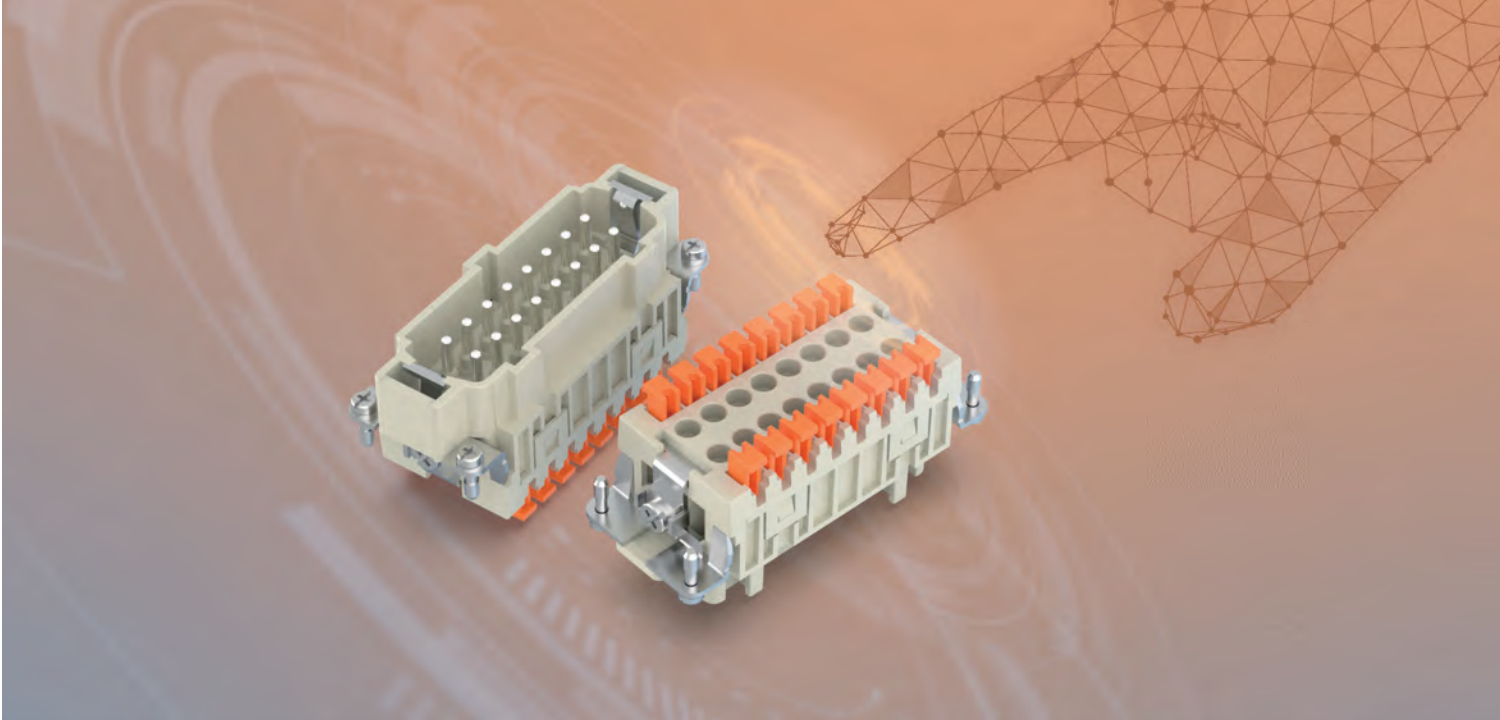
Metallic E-Xtreme® with C-TYPE lever [E.192-193](#)



CCE 24 inserts max. current load derating diagram

CSH-SQUICH® series

Connection without tools. The original one.



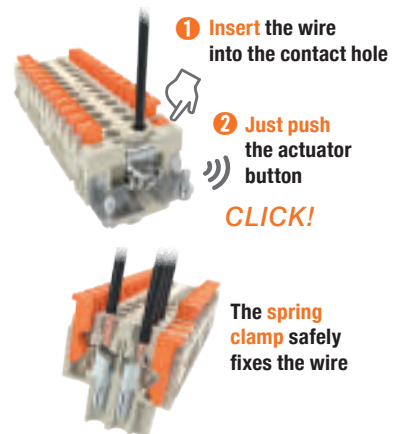
The cornerstone of ILME R&D activity focusing on easy installation and safe wiring gets its pioneering example in the **SQUICH® technology**.

Based on well-known and proven spring technology, **SQUICH®** allows tool-free connection at the **push of a button**, while providing all the advantages of traditional springs, such as resistance to temperature changes, shock and vibration.

Compatible with prepared, unprepared and solid wires, any application benefits from a safe and reliable electrical connection.

TECHNOLOGY AT A GLANCE

 **SQUICH®**





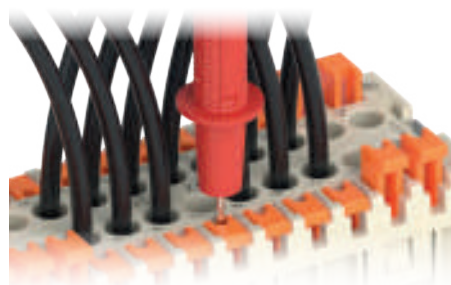
Watch our clip

KEY FEATURES

- > No special wire preparation (other than stripping)
- > No wiring tool is necessary
- > Excellent fastening solution and resistance to strong vibrations
- > Suitable for solid and flexible wires, both prepared and unprepared, with cross sectional area range of 0,14 mm² to 2,5 mm²
- > Available with stamped tin-plated (JSH..S) terminals

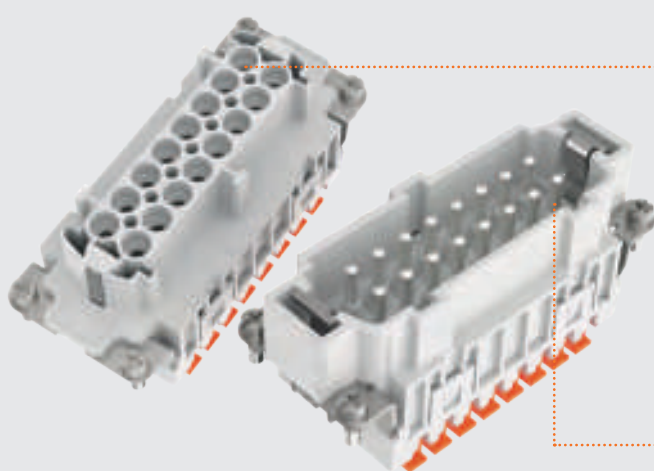
> Shaped button for terminal probing

The profile of the button used in the SQUICH® series inserts allows a measuring probe to be inserted to verify the correct wiring or an electrical measurement.



FOCUS

SQUICH® inserts series with stamped contacts



CSH 06

16 A 500 V

size **44.27**
6 poles + ⊕

Tool-less connection – SQUICH®

EN 61984 rating	16 A 500 V 6 kV 3
	16 A 400 / 690 V 6 kV 2
Rated voltage (UL / CSA)	600 V
Insulation resistance	≥ 10 GΩ
Contact resistance	≤ 3 mΩ
Ambient temperature limit	-40 °C ... +125 °C
Mechanical life (cycles)	≥ 500



ECBT2.E115072 | ECBT8.E115072
PVVA2.E506437 | PVVA8.E506437

Item	Description	Part No.	Dimension
	Male inserts with male contacts Spring clamp connections, with actuator button	CSHM 06	
	Female inserts with female contacts Spring clamp connections, with actuator button	CSHF 06	

Materials

Insert	polycarbonate (PC)
UL 94 flame rating	V-0
Colour	pebble grey, RAL 7032
Contacts	built-in, copper alloy, silver ● plated

Wiring information

Wires cross sectional area	
- unprepared	0,14 mm ² - 2,5 mm ² (AWG 26-14)
- prepared	0,14 mm ² - 2,5 mm ² (AWG 26-14)
Stripping length	9...11 mm

Enclosures size 44.27

Heavy-Duty Applications

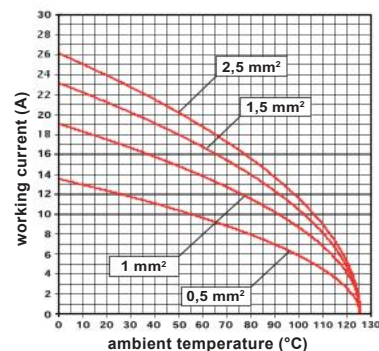
	Pages
Metallic with C-TYPE lever	E.48-53
Metallic with IL-BRID lever	E.90-91, 104
Metallic with JEI®-P lever	E.112, 119
Metallic with V-TYPE IP67 lever	E.124, 128-129
Thermoplastic T-TYPE	E.226-227, 234-235

Aggressive Environments

Metallic IP68 high protection	E.142-143
Metallic W-TYPE	E.154-155, 162
Metallic E-Xtreme®	E.174-175, 182-183, 194
Thermoplastic T-TYPE/W	E.226-227, 234-235

Specialized Applications

EMC (Electromagnetic Shielding)	E.208-209, 216
Hygienic series for food and beverage	E.244, 248
Standard applications with Central lever	E.254-255
BIG Enclosures for multiple cable entries	E.268, 272-273
COB system for switch cabinet	E.286-289
Light and Sound applications with JEI®-P lever	E.296-297



CSH 06 inserts max. current load derating diagram

CSH 10**16 A 500 V**size **57.27****10 poles +** **Tool-less connection – SQUICH®**

EN 61984 rating	16 A 500 V 6 kV 3
	16 A 400 / 690 V 6 kV 2
Rated voltage (UL / CSA)	600 V
Insulation resistance	≥ 10 GΩ
Contact resistance	≤ 3 mΩ
Ambient temperature limit	-40 °C ... +125 °C
Mechanical life (cycles)	≥ 500

CE UK EAC



ECBT2.E115072 | ECBT8.E115072
PVVA2.E506437 | PVVA8.E506437

Item	Description	Part No.	Dimension
	Male inserts with male contacts Spring clamp connections, with actuator button	CSHM 10	
	Female inserts with female contacts Spring clamp connections, with actuator button	CSHF 10	

Materials

Insert	polycarbonate (PC)
UL 94 flame rating	V-0
Colour	pebble grey, RAL 7032
Contacts	built-in, copper alloy, silver ● plated

Wiring information

Wires cross sectional area	
- unprepared	0,14 mm ² - 2,5 mm ² (AWG 26-14)
- prepared	0,14 mm ² - 2,5 mm ² (AWG 26-14)
Stripping length	9...11 mm

Enclosures size 57.27**Pages****Heavy-Duty Applications**

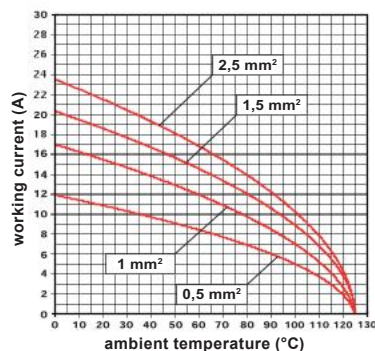
Metallic with C-TYPE lever	E.54-61
Metallic with IL-BRID lever	E.92-96 105
Metallic with JEI®-P lever	E.113-114 119
Metallic with V-TYPE IP67 lever	E.125 130-131
Thermoplastic T-TYPE	E.228-229 234-235

Aggressive Environments

Metallic IP68 high protection	E.144-145
Metallic W-TYPE	E.156-157 163
Metallic E-Xtreme®	E.176-177 184-185 195
Thermoplastic T-TYPE/W	E.228-229 234-235

Specialized Applications

EMC (Electromagnetic Shielding)	E.210-211 217
Hygienic series for food and beverage	E.245 248
Standard applications with Central lever	E.256-257
BIG Enclosures for multiple cable entries	E.269 274-275
COB system for switch cabinet	E.286-289
Light and Sound applications with JEI®-P lever	E.298-299



CSH 10 inserts max. current load derating diagram

CSH 16

16 A 500 V

size **77.27**
16 poles + ⊕

Tool-less connection – SQUICH®

EN 61984 rating	16 A 500 V 6 kV 3
	16 A 400 / 690 V 6 kV 2
Rated voltage (UL / CSA)	600 V
Insulation resistance	≥ 10 GΩ
Contact resistance	≤ 3 mΩ
Ambient temperature limit	-40 °C ... +125 °C
Mechanical life (cycles)	≥ 500



Item	Description	Part No.	Dimension
	Male inserts with male contacts Spring clamp connections, with actuator button	CSHM 16	
	Female inserts with female contacts Spring clamp connections, with actuator button	CSHF 16	

Materials

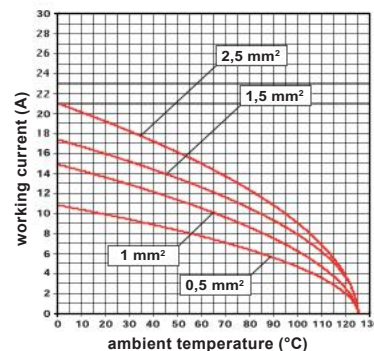
Insert	polycarbonate (PC)
UL 94 flame rating	V-0
Colour	pebble grey, RAL 7032
Contacts	built-in, copper alloy, silver ● plated

Wiring information

Wires cross sectional area	
- unprepared	0,14 mm ² - 2,5 mm ² (AWG 26-14)
- prepared	0,14 mm ² - 2,5 mm ² (AWG 26-14)
Stripping length	9...11 mm

Enclosures size 77.27

Heavy-Duty Applications	Pages
Metallic with C-TYPE lever	E.62-69
Metallic with IL-BRID lever	E.96-99, 106
Metallic with JEI®-P lever	E.115-116, 119
Metallic with V-TYPE IP67 lever	E.126, 132-133
Thermoplastic T-TYPE	E.230-231, 234-235
Aggressive Environments	
Metallic IP68 high protection	E.146-147
Metallic W-TYPE	E.158-159, 164
Metallic E-Xtreme®	E.178-179, 186-187, 196
Thermoplastic T-TYPE/W	E.230-231, 234-235
Specialized Applications	
EMC (Electromagnetic Shielding)	E.212-213, 218
Hygienic series for food and beverage	E.248, 248
Standard applications with Central lever	E.258-259
BIG Enclosures for multiple cable entries	E.270, 276-277
COB system for switch cabinet	E.286-289
Light and Sound applications with JEI®-P lever	E.300-301



CSH 16 inserts max. current load derating diagram



CSH 24

16 A 500 V

size **104.27**


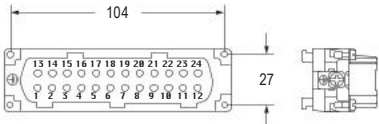

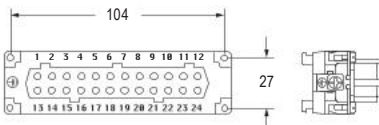
24 poles + ⊕

Tool-less connection – SQUICH®

EN 61984 rating	16 A 500 V 6 kV 3
	16 A 400 / 690 V 6 kV 2
Rated voltage (UL / CSA)	600 V
Insulation resistance	≥ 10 GΩ
Contact resistance	≤ 3 mΩ
Ambient temperature limit	-40 °C ... +125 °C
Mechanical life (cycles)	≥ 500



ECBT2.E115072 | ECBT8.E115072
PVVA2.E506437 | PVVA8.E506437

Item	Description	Part No.	Dimension
	Male inserts with male contacts Spring clamp connections, with actuator button	CSHM 24	
	Female inserts with female contacts Spring clamp connections, with actuator button	CSHF 24	

CSH

B

Materials

Insert	polycarbonate (PC)
UL 94 flame rating	V-0
Colour	pebble grey, RAL 7032
Contacts	built-in, copper alloy, silver ● plated

Wiring information

Wires cross sectional area	
- unprepared	0,14 mm ² - 2,5 mm ² (AWG 26-14)
- prepared	0,14 mm ² - 2,5 mm ² (AWG 26-14)
Stripping length	9...11 mm

Enclosures size 104.27

Pages

Heavy-Duty Applications

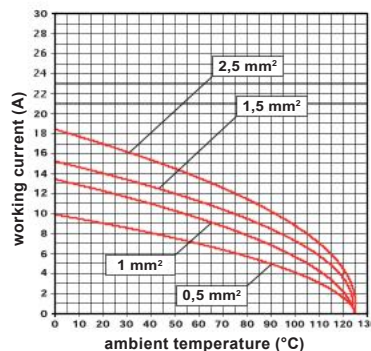
Metallic with C-TYPE lever	E.70-77
Metallic with IL-BRID lever	E.100-103 107
Metallic with JEI®-P lever	E.117-119
Metallic with V-TYPE IP67 lever	E.127 134-135
Thermoplastic T-TYPE	E.232-235

Aggressive Environments

Metallic IP68 high protection	E.148-149
Metallic W-TYPE	E.160-161 165
Metallic E-Xtreme®	E.180-181 188-189 197
Thermoplastic T-TYPE/W	E.232-235

Specialized Applications

EMC (Electromagnetic Shielding)	E.214-215 219
Hygienic series for food and beverage	E.247-248
Standard applications with Central lever	E.260-261
BIG Enclosures for multiple cable entries	E.271 278-279
COB system for switch cabinet	E.286-289
Light and Sound applications with JEI®-P lever	E.302-303



CSH 24 inserts max. current load derating diagram

CSH 16 + CSH 16 N

16 A 500 V

size **77.62**


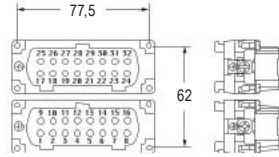

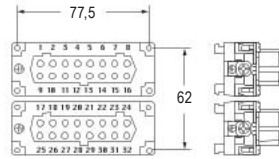
32 poles + ⊕

Tool-less connection – SQUICH®

EN 61984 rating	16 A 500 V 6 kV 3
	16 A 400 / 690 V 6 kV 2
Rated voltage (UL / CSA)	600 V
Insulation resistance	≥ 10 GΩ
Contact resistance	≤ 3 mΩ
Ambient temperature limit	-40 °C ... +125 °C
Mechanical life (cycles)	≥ 500



ECB2.E115072 | ECBT8.E115072
PVVA2.E506437 | PVVA8.E506437

Item	Description	Part No.	Dimension
	Male inserts, No. (1-16) Male inserts, No. (17-32) Spring clamp connections, with actuator button	CSHM 16 CSHM 16 N	
	Female inserts, No. (1-16) Female inserts, No. (17-32) Spring clamp connections, with actuator button	CSHF 16 CSHF 16 N	

CSH
B

Materials

Insert	polycarbonate (PC)
UL 94 flame rating	V-0
Colour	pebble grey, RAL 7032
Contacts	built-in, copper alloy, silver ● plated

Wiring information

Wires cross sectional area	
- unprepared	0,14 mm ² - 2,5 mm ² (AWG 26-14)
- prepared	0,14 mm ² - 2,5 mm ² (AWG 26-14)
Stripping length	9...11 mm

Enclosures size 77.62

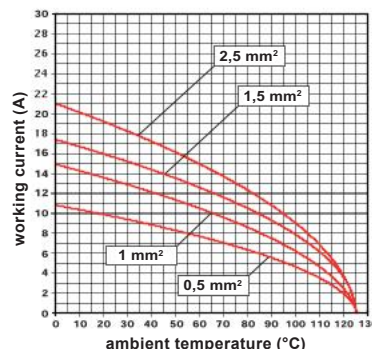
Pages

Heavy-Duty Applications

Metallic with C-TYPE lever	E.78-83
----------------------------	-------------------------

Aggressive Environments

Metallic W-TYPE with C-TYPE lever	E.166-167
Metallic E-Xtreme® with C-TYPE lever	E.190-191



CSH 16 inserts max. current load derating diagram

CSH 24 + CSH 24 N

16 A 500 V

size **104.62**

48 poles + ⊕


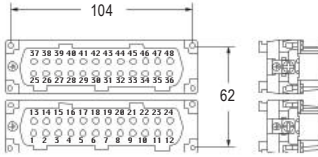

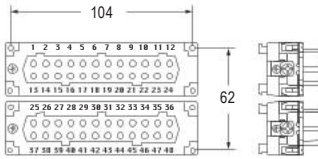
Tool-less connection – SQUICH®

EN 61984 rating	16 A 500 V 6 kV 3
	16 A 400 / 690 V 6 kV 2
Rated voltage (UL / CSA)	600 V
Insulation resistance	≥ 10 GΩ
Contact resistance	≤ 3 mΩ
Ambient temperature limit	-40 °C ... +125 °C
Mechanical life (cycles)	≥ 500

CE UK EAC



ECBT2.E115072 | ECBT8.E115072
 PVVA2.E506437 | PVVA8.E506437

Item	Description	Part No.	Dimension
	Male inserts, No. (1-24) Male inserts, No. (25-48) Spring clamp connections, with actuator button	CSHM 24 CSHM 24 N	
	Female inserts, No. (1-24) Female inserts, No. (25-48) Spring clamp connections, with actuator button	CSHF 24 CSHF 24 N	

CSH

B

Materials

Insert	polycarbonate (PC)
UL 94 flame rating	V-0
Colour	pebble grey, RAL 7032
Contacts	built-in, copper alloy, silver ● plated

Wiring information

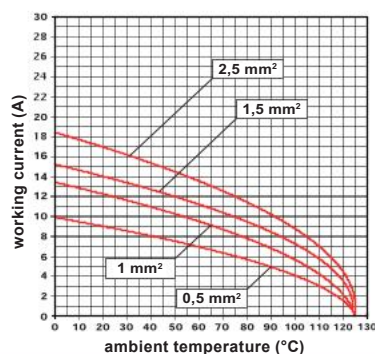
Wires cross sectional area	
- unprepared	0,14 mm ² - 2,5 mm ² (AWG 26-14)
- prepared	0,14 mm ² - 2,5 mm ² (AWG 26-14)
Stripping length	9...11 mm

Enclosures size 104.62Pages **Heavy-Duty Applications**

Metallic with C-TYPE lever	E.84-88
----------------------------	-------------------------

Aggressive Environments

Metallic W-TYPE with C-TYPE lever	E.168-169
Metallic E-Xtreme® with C-TYPE lever	E.192-193

**CSH 24 inserts max. current load derating diagram**

JSH 06 S JEI®

16 A 500 V

size **44.27**

6 poles + ⊕

Tool-less connection – SQUICH®

EN 61984 rating	16 A 500 V 6 kV 3
Rated voltage (UL / CSA)	600 V
Insulation resistance	≥ 10 GΩ
Contact resistance	≤ 3 mΩ
Ambient temperature limit	-40 °C ... +125 °C
Mechanical life (cycles)	≥ 200



CAIUS ECBT2.E115072 | ECBT8.E115072

Item	Description	Part No.	Dimension
	Male inserts with male contacts Spring clamp connections, with actuator button	JSHM 06 S	
	Female inserts with female contacts Spring clamp connections, with actuator button	JSHF 06 S	

Materials

Insert	polycarbonate (PC)
UL 94 flame rating	V-0
Colour	white, RAL 7035
Contacts	built-in stamped, copper alloy, tin ● plated

Wiring information

Wires cross sectional area	
- unprepared	0,14 mm ² - 2,5 mm ² (AWG 26-14)
- prepared	0,14 mm ² - 2,5 mm ² (AWG 26-14)
Stripping length	9...11 mm

Enclosures size 44.27

Heavy-Duty Applications

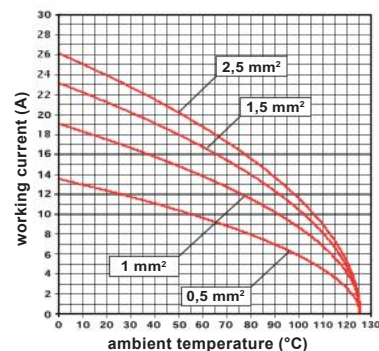
	Pages
Metallic with C-TYPE lever	E.48-53
Metallic with IL-BRID lever	E.90-91, 104
Metallic with JEI®-P lever	E.112, 119
Metallic with V-TYPE IP67 lever	E.124, 128-129
Thermoplastic T-TYPE	E.226-227, 234-235

Aggressive Environments

Metallic IP68 high protection	E.142-143
Metallic W-TYPE	E.154-155, 162
Metallic E-Xtreme®	E.174-175, 182-183, 194
Thermoplastic T-TYPE/W	E.226-227, 234-235

Specialized Applications

EMC (Electromagnetic Shielding)	E.208-209, 216
Hygienic series for food and beverage	E.244, 248
Standard applications with Central lever	E.254-255
BIG Enclosures for multiple cable entries	E.268, 272-273
COB system for switch cabinet	E.286-289
Light and Sound applications with JEI®-P lever	E.296-297



JSH 06 inserts max. current load derating diagram


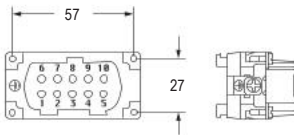

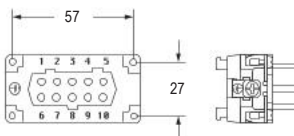
JSH..S
B

JSH 10 S JEI®**16 A 500 V**size **57.27****10 poles + ⊕****Tool-less connection – SQUICH®**

EN 61984 rating	16 A 500 V 6 kV 3
Rated voltage (UL / CSA)	600 V
Insulation resistance	≥ 10 GΩ
Contact resistance	≤ 3 mΩ
Ambient temperature limit	-40 °C ... +125 °C
Mechanical life (cycles)	≥ 200

CE UK EAC

C^{AL}US ECBT2.E115072 | ECBT8.E115072

Item	Description	Part No.	Dimension
	Male inserts with male contacts Spring clamp connections, with actuator button	JSHM 10 S	
	Female inserts with female contacts Spring clamp connections, with actuator button	JSHF 10 S	

Materials

Insert	polycarbonate (PC)
UL 94 flame rating	V-0
Colour	white, RAL 7035
Contacts	built-in stamped, copper alloy, tin ● plated

Wiring information

Wires cross sectional area	
- unprepared	0,14 mm ² - 2,5 mm ² (AWG 26-14)
- prepared	0,14 mm ² - 2,5 mm ² (AWG 26-14)
Stripping length	9...11 mm

Enclosures size 57.27**Pages****Heavy-Duty Applications**

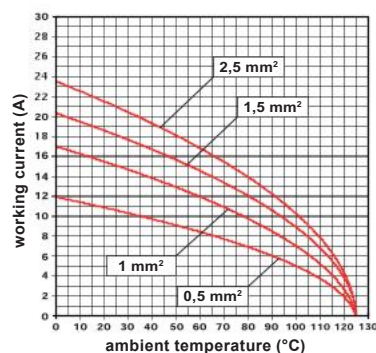
Metallic with C-TYPE lever	E.54-61
Metallic with IL-BRID lever	E.92-95 105
Metallic with JEI®-P lever	E.113-114 119
Metallic with V-TYPE IP67 lever	E.125 130-131
Thermoplastic T-TYPE	E.228-229 234-235

Aggressive Environments

Metallic IP68 high protection	E.144-145
Metallic W-TYPE	E.156-157 163
Metallic E-Xtreme®	E.176-177 184-185 195
Thermoplastic T-TYPE/W	E.228-229 234-235

Specialized Applications

EMC (Electromagnetic Shielding)	E.210-211 217
Hygienic series for food and beverage	E.245 248
Standard applications with Central lever	E.256-257
BIG Enclosures for multiple cable entries	E.269 274-275
COB system for switch cabinet	E.286-289
Light and Sound applications with JEI®-P lever	E.298-299

**JSH 10 inserts max. current load derating diagram**

JSH 16 S JEI®

16 A 500 V

size **77.27**
16 poles + ⊕

Tool-less connection – SQUICH®

EN 61984 rating	16 A 500 V 6 kV 3
Rated voltage (UL / CSA)	600 V
Insulation resistance	≥ 10 GΩ
Contact resistance	≤ 3 mΩ
Ambient temperature limit	-40 °C ... +125 °C
Mechanical life (cycles)	≥ 200



CAIUS ECBT2.E115072 | ECBT8.E115072

Item	Description	Part No.	Dimension
	Male inserts with male contacts Spring clamp connections, with actuator button	JSHM 16 S	
	Female inserts with female contacts Spring clamp connections, with actuator button	JSHF 16 S	

JSH..S
B

Materials

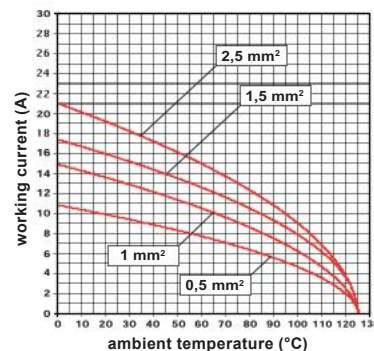
Insert	polycarbonate (PC)
UL 94 flame rating	V-0
Colour	white, RAL 7035
Contacts	built-in stamped, copper alloy, tin ● plated

Wiring information

Wires cross sectional area	
- unprepared	0,14 mm ² - 2,5 mm ² (AWG 26-14)
- prepared	0,14 mm ² - 2,5 mm ² (AWG 26-14)
Stripping length	9...11 mm

Enclosures size 77.27

Heavy-Duty Applications	Pages
Metallic with C-TYPE lever	E.62-69
Metallic with IL-BRID lever	E.96-99, 106
Metallic with JEI®-P lever	E.115-116, 119
Metallic with V-TYPE IP67 lever	E.126, 132-133
Thermoplastic T-TYPE	E.230-231, 234-235
Aggressive Environments	
Metallic IP68 high protection	E.146-147
Metallic W-TYPE	E.158-159, 164
Metallic E-Xtreme®	E.178-179, 186-187, 196
Thermoplastic T-TYPE/W	E.230-231, 234-235
Specialized Applications	
EMC (Electromagnetic Shielding)	E.212-213, 218
Hygienic series for food and beverage	E.246, 248
Standard applications with Central lever	E.258-259
BIG Enclosures for multiple cable entries	E.270, 276-277
COB system for switch cabinet	E.286-289
Light and Sound applications with JEI®-P lever	E.300-301



JSH 16 inserts max. current load derating diagram

JSH 24 S JEI®

16 A 500 V

size **104.27**

24 poles + ⊕

Tool-less connection – SQUICH®

EN 61984 rating	16 A 500 V 6 kV 3
Rated voltage (UL / CSA)	600 V
Insulation resistance	≥ 10 GΩ
Contact resistance	≤ 3 mΩ
Ambient temperature limit	-40 °C ... +125 °C
Mechanical life (cycles)	≥ 200

CE UK EAC

CBC DNV VERITAS

CAIUS ECBT2.E115072 | ECBT8.E115072

Item	Description	Part No.	Dimension
	Male inserts with male contacts Spring clamp connections, with actuator button	JSHM 24 S	
	Female inserts with female contacts Spring clamp connections, with actuator button	JSHF 24 S	

Materials

Insert	polycarbonate (PC)
UL 94 flame rating	V-0
Colour	white, RAL 7035
Contacts	built-in stamped, copper alloy, tin ● plated

Wiring information

Wires cross sectional area	
- unprepared	0,14 mm ² - 2,5 mm ² (AWG 26-14)
- prepared	0,14 mm ² - 2,5 mm ² (AWG 26-14)
Stripping length	9...11 mm

Enclosures size 104.27

Pages

Heavy-Duty Applications

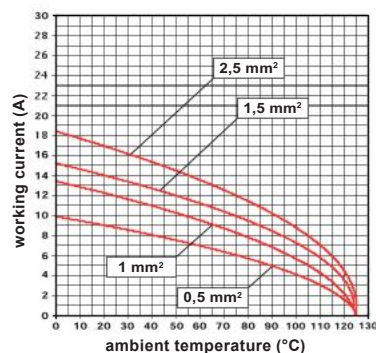
Metallic with C-TYPE lever	E.70-77
Metallic with IL-BRID lever	E.100-103 107
Metallic with JEI®-P lever	E.117-119
Metallic with V-TYPE IP67 lever	E.127 134-135
Thermoplastic T-TYPE	E.232-235

Aggressive Environments

Metallic IP68 high protection	E.148-149
Metallic W-TYPE	E.160-161 165
Metallic E-Xtreme®	E.180-181 188-189 197
Thermoplastic T-TYPE/W	E.232-235

Specialized Applications

EMC (Electromagnetic Shielding)	E.214-215 219
Hygienic series for food and beverage	E.247-248
Standard applications with Central lever	E.260-261
BIG Enclosures for multiple cable entries	E.271 278-279
COB system for switch cabinet	E.286-289
Light and Sound applications with JEI®-P lever	E.302-303



JSH 24 inserts max. current load derating diagram

JSH 16 S + JSH 16 SN JEI®

16 A 500 V

size **77.62**


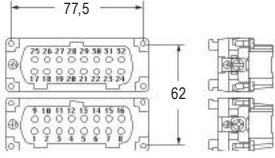

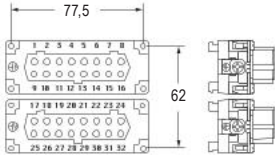
32 poles + ⊕

Tool-less connection – SQUICH®

EN 61984 rating	16 A 500 V 6 kV 3
Rated voltage (UL / CSA)	600 V
Insulation resistance	≥ 10 GΩ
Contact resistance	≤ 3 mΩ
Ambient temperature limit	-40 °C ... +125 °C
Mechanical life (cycles)	≥ 200



CAIUS ECBT2.E115072 | ECBT8.E115072

Item	Description	Part No.	Dimension
	Male inserts, No. (1-16) Male inserts, No. (17-32) Spring clamp connections, with actuator button	JSHM 16 S JSHM 16 SN	
	Female inserts, No. (1-16) Female inserts, No. (17-32) Spring clamp connections, with actuator button	JSHF 16 S JSHF 16 SN	

JSH..S

B

Materials

Insert	polycarbonate (PC)
UL 94 flame rating	V-0
Colour	white, RAL 7035
Contacts	built-in stamped, copper alloy, tin ● plated

Wiring information

Wires cross sectional area	
- unprepared	0,14 mm ² - 2,5 mm ² (AWG 26-14)
- prepared	0,14 mm ² - 2,5 mm ² (AWG 26-14)
Stripping length	9...11 mm

Enclosures size 77.62

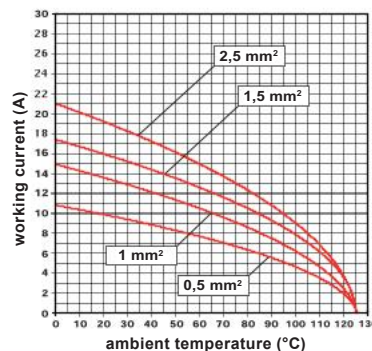
Pages 

Heavy-Duty Applications

Metallic with C-TYPE lever	E.78-83
----------------------------	-------------------------

Aggressive Environments

Metallic W-TYPE with C-TYPE lever	E.166-167
Metallic E-Xtreme® with C-TYPE lever	E.190-191



JSH 16 inserts max. current load derating diagram



JSH 24 S + JSH 24 SN JEI®

16 A 500 V

size **104.62**


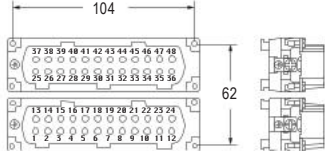

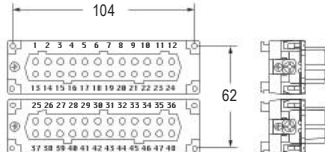
48 poles + ⊕

Tool-less connection – SQUICH®

EN 61984 rating	16 A 500 V 6 kV 3
Rated voltage (UL / CSA)	600 V
Insulation resistance	≥ 10 GΩ
Contact resistance	≤ 3 mΩ
Ambient temperature limit	-40 °C ... +125 °C
Mechanical life (cycles)	≥ 200



ALUS ECBT2.E115072 | ECBT8.E115072

Item	Description	Part No.	Dimension
	Male inserts, No. (1-24) Male inserts, No. (25-48) Spring clamp connections, with actuator button	JSHM 24 S JSHM 24 SN	
	Female inserts, No. (1-24) Female inserts, No. (25-48) Spring clamp connections, with actuator button	JSHF 24 S JSHF 24 SN	

JSH S B

Materials

Insert	polycarbonate (PC)
UL 94 flame rating	V-0
Colour	white, RAL 7035
Contacts	built-in stamped, copper alloy, tin ● plated

Wiring information

Wires cross sectional area	
- unprepared	0,14 mm ² - 2,5 mm ² (AWG 26-14)
- prepared	0,14 mm ² - 2,5 mm ² (AWG 26-14)
Stripping length	9...11 mm

Enclosures size 104.62

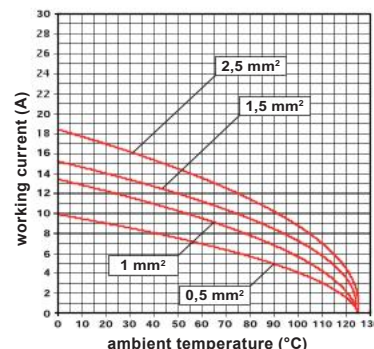
Pages

Heavy-Duty Applications

Metallic with C-TYPE lever	E.84-88
----------------------------	-------------------------

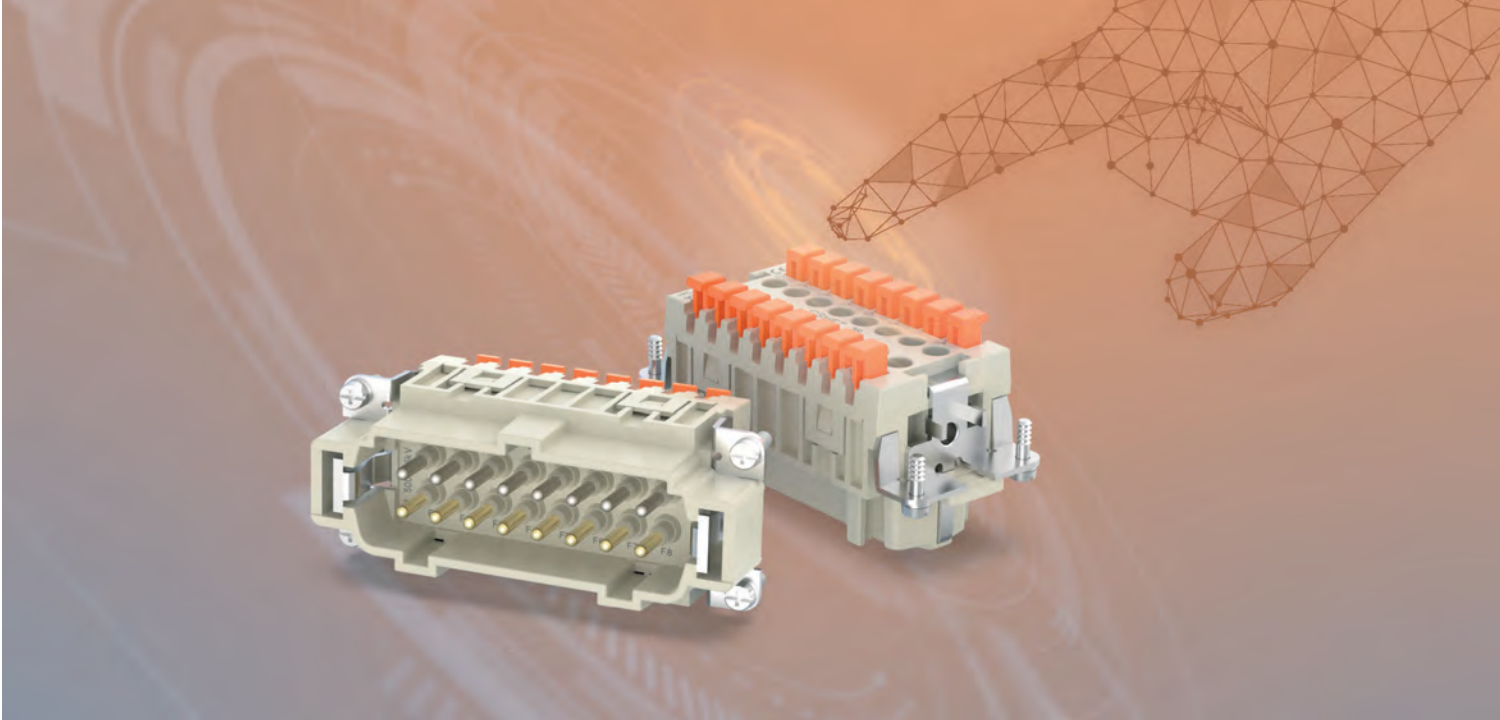
Aggressive Environments

Metallic W-TYPE with C-TYPE lever	E.168-169
Metallic E-Xtreme® with C-TYPE lever	E.192-193



JSH 24 inserts max. current load derating diagram

CSHT-SQUICH® series for Type J (Fe/CuNi) thermocouples



This new **CSHT** variant of series **SQUICH® CSH** inserts employs one row of contacts made by *iron* (Fe, gold plated to provide corrosion resistance), the other facing row of contacts made by *constantan* alloy (CuNi), for quick, easy, releasable/reusable wiring of the popular **type J** thermocouples according to IEC 60584-1.

✍ NOTE – Type J thermocouples cover a temperature measurement range - 210 °C to + 760 °C. This type's susceptibility to high-temperature degradation limits its life, but it is often used in injection moulding because of its compatibility with vacuum and inert atmospheres. Compared to type K thermocouples, it has a smaller temperature range and a shorter lifespan at higher temperatures, but in terms of cost and reliability they are equivalent.

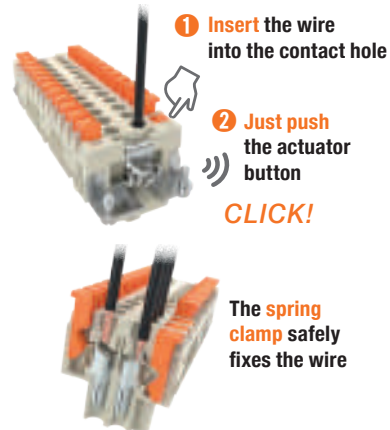
While these special-use connector inserts bear the same rated insulation voltage (500 V 6 kV) and the same current rating (16 A) of the standard versions of series CSH for power transmission, the employed special contacts made with *Fe* (iron) and *CuNi* (constantan) respectively cannot provide the same contact resistance, thus the current carrying capacity of silver-plated brass contacts.

✍ NOTE – Resistivity of iron (*Fe*) varies from 1,1× to 1,7× that of brass, depending the title of copper in the brass alloy, while resistivity of constantan (*CuNi*) is from 5,4× to 8,2× that of brass.

Indeed, in thermocouple applications there is neither need for such voltage nor for such current-carrying capacity. The thermocouple current is in the milliampere range, the voltage is in the millivolt range, with the purpose to avoid *offset* voltages due to contact among dissimilar metals.

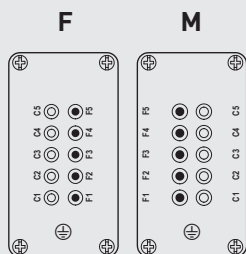
TECHNOLOGY AT A GLANCE

 **SQUICH®**

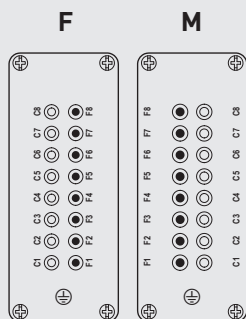


FOCUS

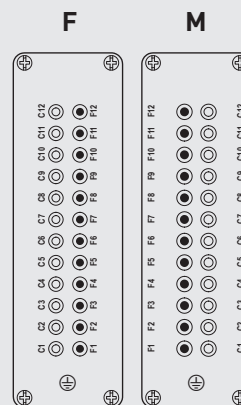
Fe / CuNi contacts layout



> **CSHFT /MT 10**
for up to 5 Type J thermocouples



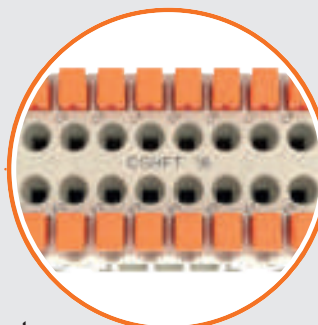
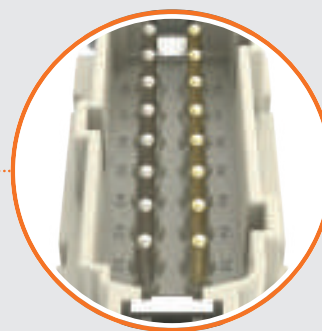
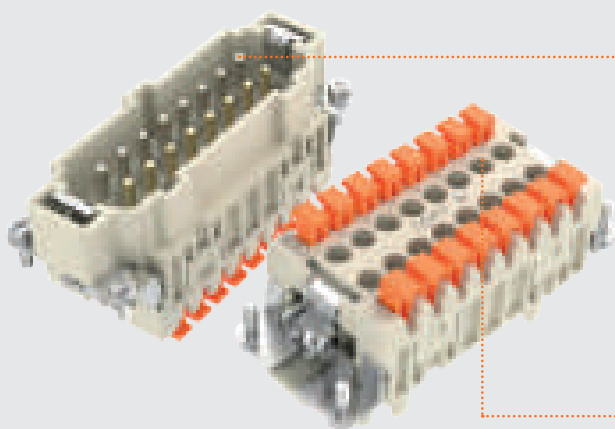
> **CSHFT /MT 16**
for up to 8 Type J thermocouples



> **CSHFT /MT 24**
for up to 12 Type J thermocouples

contacts side - front view

- CuNi contact
- Fe contact (gold plated)
- M = male insert
- F = female insert



▶ Variants with mixed combination of standard brass contacts (for power circuits) and type J thermocouple contacts are possible upon request for reasonable production quantities. Please contact our commercial offices.

CSHT 10

16 A 500 V

size **57.27**

10 poles + ⊕


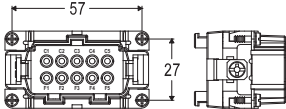

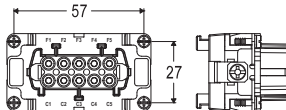
Tool-less connection – SQUICH®

EN 61984 rating	16 A 500 V 6 kV 3
Rated voltage (UL / CSA)	600 V
Insulation resistance	≥ 10 GΩ
Contact resistance	≤ 3 mΩ
Ambient temperature limit	-40 °C ... +125 °C
Mechanical life (cycles)	≥ 500

CE UK (pending: EAC)

(pending: CQC, DNV and BV)

(pending: cURus)

Item	Description	Part No.	Dimension
	Male inserts with male contacts Spring clamp connections, with actuator button Poles with built-in iron contacts (gold plated) are marked with "F" letter, poles with built-in constantan contacts are marked with "C" letter.	CSHMT 10	
	Female inserts with female contacts Spring clamp connections, with actuator button Poles with built-in iron contacts (gold plated) are marked with "F" letter, poles with built-in constantan contacts are marked with "C" letter.	CSHFT 10	

CSHT

B

Materials

Insert	polycarbonate (PC)
UL 94 flame rating	V-0
Colour	pebble grey, RAL 7032
Contacts	
- poles F1-F5	built-in turned, iron ● (Fe, gold plated)
- poles C1-C5	built-in turned, constantan ● (CuNi)

Wiring information

Wires cross sectional area	
- unprepared	0,14 mm ² - 2,5 mm ² (AWG 26-14)
- prepared	0,14 mm ² - 2,5 mm ² (AWG 26-14)
Stripping length	9...11 mm

Enclosures size 57.27

Heavy-Duty Applications	Pages
Metallic with C-TYPE lever	E.54-61
Metallic with IL-BRID lever	E.92-95,105
Metallic with JEI®-P lever	E.113-114,119
Metallic with V-TYPE IP67 lever	E.125,130-131
Thermoplastic T-TYPE	E.228-229,234-235
Aggressive Environments	
Metallic IP68 high protection	E.144-145
Metallic W-TYPE	E.156-157,163
Metallic E-Xtreme®	E.176-177,184-185,195
Thermoplastic T-TYPE/W	E.228-229,234-235
Specialized Applications	
EMC (Electromagnetic Shielding)	E.210-211,217
Hygienic series for food and beverage	E.245,248
Standard applications with Central lever	E.256-257
BIG Enclosures for multiple cable entries	E.269,274-275
COB system for switch cabinet	E.286-289
Light and Sound applications with JEI®-P lever	E.298-299

CSHT 16

16 A 500 V

size **77.27**

16 poles + ⊕


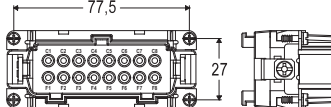

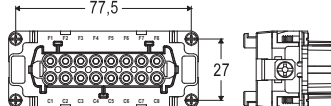
Tool-less connection – SQUICH®

EN 61984 rating	16 A 500 V 6 kV 3
Rated voltage (UL / CSA)	600 V
Insulation resistance	≥ 10 GΩ
Contact resistance	≤ 3 mΩ
Ambient temperature limit	-40 °C ... +125 °C
Mechanical life (cycles)	≥ 500

CE UK (pending: EAC)

(pending: CQC, DNV and BV)

(pending: cURus)

Item	Description	Part No.	Dimension
	<p>Male inserts with male contacts Spring clamp connections, with actuator button</p> <p>Poles with built-in iron contacts (gold plated) are marked with "F" letter, poles with built-in constantan contacts are marked with "C" letter.</p>	CSHMT 16	
	<p>Female inserts with female contacts Spring clamp connections, with actuator button</p> <p>Poles with built-in iron contacts (gold plated) are marked with "F" letter, poles with built-in constantan contacts are marked with "C" letter.</p>	CSHFT 16	

Materials

Insert	polycarbonate (PC)
UL 94 flame rating	V-0
Colour	pebble grey, RAL 7032
Contacts	
- poles F1-F8	built-in turned, iron ● (Fe, gold plated)
- poles C1-C8	built-in turned, constantan ● (CuNi)

Wiring information

Wires cross sectional area	
- unprepared	0,14 mm ² - 2,5 mm ² (AWG 26-14)
- prepared	0,14 mm ² - 2,5 mm ² (AWG 26-14)
Stripping length	9...11 mm

Enclosures size 77.27

Pages

Heavy-Duty Applications	Pages
Metallic with C-TYPE lever	E.62-69
Metallic with IL-BRID lever	E.96-99,106
Metallic with JEI®-P lever	E.115-116,119
Metallic with V-TYPE IP67 lever	E.126,132-133
Thermoplastic T-TYPE	E.230-231,234-235
Aggressive Environments	Pages
Metallic IP68 high protection	E.146-147
Metallic W-TYPE	E.158-159,164
Metallic E-Xtreme®	E.178-179,186-187,196
Thermoplastic T-TYPE/W	E.230-231,234-235
Specialized Applications	Pages
EMC (Electromagnetic Shielding)	E.212-213,218
Hygienic series for food and beverage	E.246,248
Standard applications with Central lever	E.258-259
BIG Enclosures for multiple cable entries	E.270,276-277
COB system for switch cabinet	E.286-289
Light and Sound applications with JEI®-P lever	E.300-301

CSHT 24

16 A 500 V

size **104.27**

24 poles + ⊕


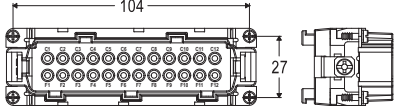

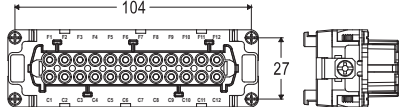
Tool-less connection – SQUICH®

EN 61984 rating	16 A 500 V 6 kV 3
Rated voltage (UL / CSA)	600 V
Insulation resistance	≥ 10 GΩ
Contact resistance	≤ 3 mΩ
Ambient temperature limit	-40 °C ... +125 °C
Mechanical life (cycles)	≥ 500

CE UK (pending: EAC)

(pending: CQC, DNV and BV)

(pending: cURus)

Item	Description	Part No.	Dimension
	<p>Male inserts with male contacts Spring clamp connections, with actuator button</p> <p>Poles with built-in iron contacts (gold plated) are marked with "F" letter, poles with built-in constantan contacts are marked with "C" letter.</p>	CSHMT 24	
	<p>Female inserts with female contacts Spring clamp connections, with actuator button</p> <p>Poles with built-in iron contacts (gold plated) are marked with "F" letter, poles with built-in constantan contacts are marked with "C" letter.</p>	CSHFT 24	

Materials

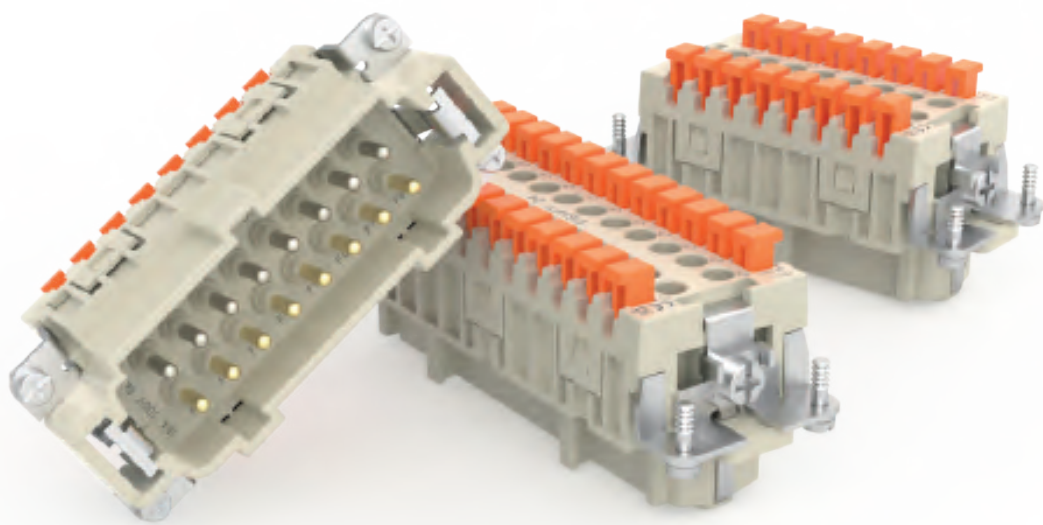
Insert	polycarbonate (PC)
UL 94 flame rating	V-0
Colour	pebble grey, RAL 7032
Contacts	
- poles F1-F12	built-in turned, iron ● (Fe, gold plated)
- poles C1-C12	built-in turned, constantan ● (CuNi)

Wiring information

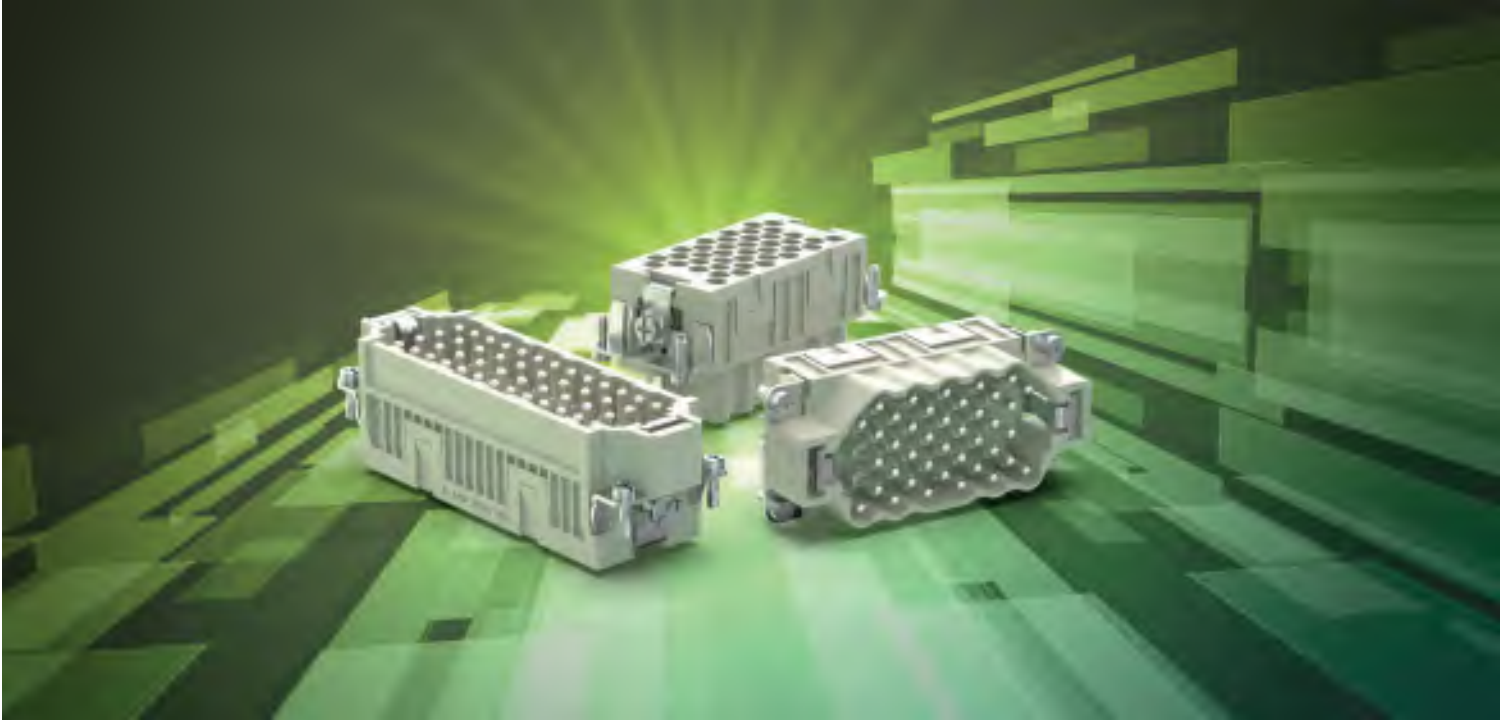
Wires cross sectional area	
- unprepared	0,14 mm ² - 2,5 mm ² (AWG 26-14)
- prepared	0,14 mm ² - 2,5 mm ² (AWG 26-14)
Stripping length	9...11 mm

Enclosures size 104.27

Heavy-Duty Applications	Pages
Metallic with C-TYPE lever	E.70-77
Metallic with IL-BRID lever	E.100-103,107
Metallic with JEI®-P lever	E.117-119
Metallic with V-TYPE IP67 lever	E.127,134-135
Thermoplastic T-TYPE	E.232-235
Aggressive Environments	
Metallic IP68 high protection	E.148-149
Metallic W-TYPE	E.160-161,165
Metallic E-Xtreme®	E.180-181,188-189,197
Thermoplastic T-TYPE/W	E.232-235
Specialized Applications	
EMC (Electromagnetic Shielding)	E.214-215,219
Hygienic series for food and beverage	E.247-248
Standard applications with Central lever	E.260-261
BIG Enclosures for multiple cable entries	E.271,278-279
COB system for switch cabinet	E.286-289
Light and Sound applications with JEI®-P lever	E.302-303



CQE and CQEE series



CQE series overview

CQE connector inserts have been designed as a high-density alternative to the 16 A **CCE** series. Available in crimp termination technology, they permit almost twice the wiring capability of the CCE inserts for optimal cost and space efficiency. CQE crimp

connector inserts are designed for removable crimp contacts series CC (solid pin Ø 2,5 mm, for conductors up to 4 mm² - AWG 12) with a rated current of up to 16 A per pole.

CQEE series overview

CQEE connector inserts series are the logical extension of the existing **CQE** for removable crimp contacts series CC (16 A max). With the same number of circuits, it is conversely possible to reduce the size of the connector inserts and the related hood and housing, thus reducing the overall cost.

Connector inserts series CQEE compared with the same size CQE connector inserts, provide a sensibly higher number of contacts:

- > **64P + ⊕** instead of 46P + ⊕ for size 104.27 (+39%)
- > **40P + ⊕** instead of 32P + ⊕ for size 77.27 (+25%).

Connector inserts series CQEE replace in the same size (77.27, 104.27) and with the same contact density (40P + ⊕ and 64P + ⊕) the corresponding inserts of series CD for removable crimp contacts series CD (10 A max).

This may be particularly useful when it is required:

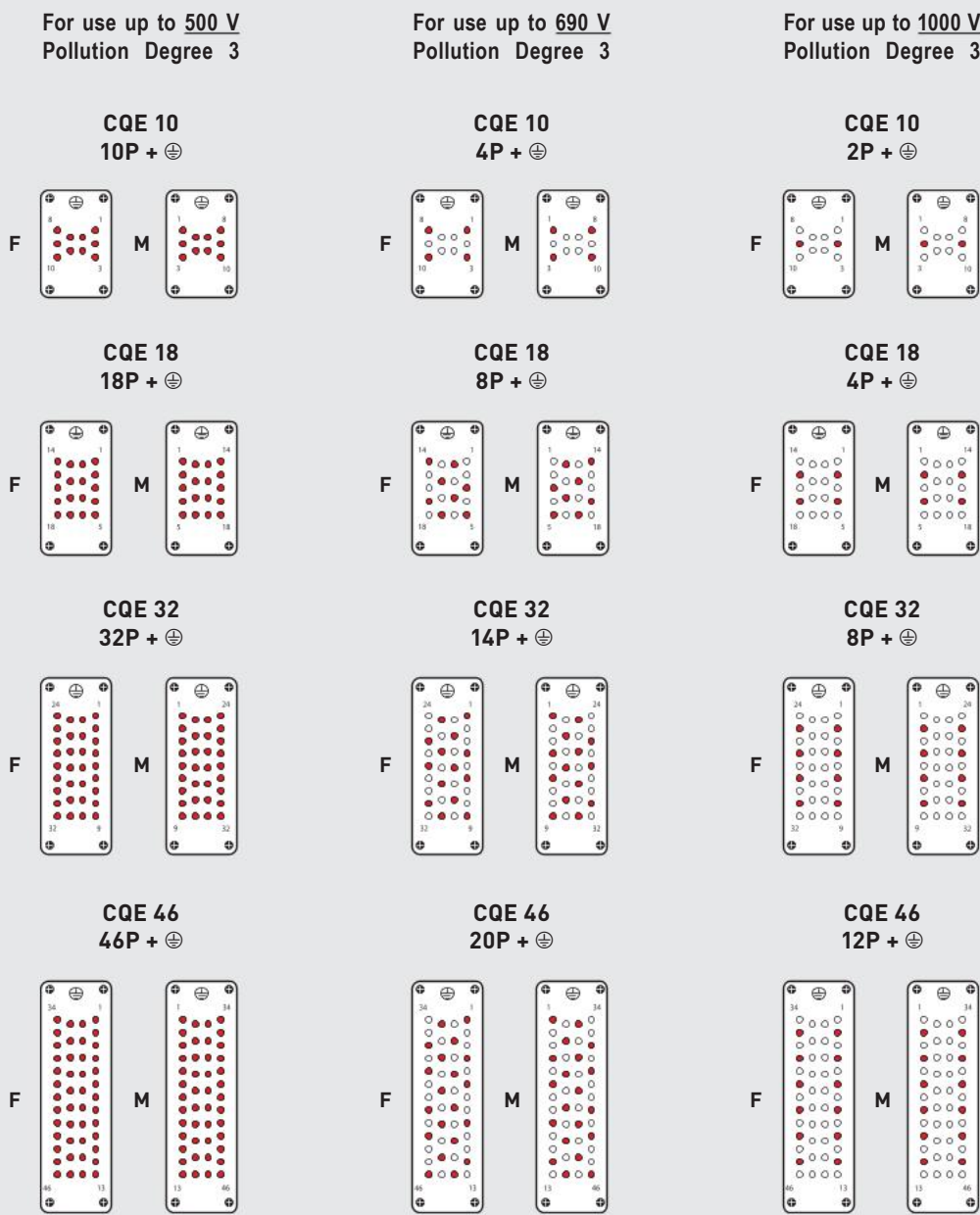
- > to use the connector at a higher rated voltage: CQEE covers use at 500 V / 6 kV / 3 where CD stops at 250 V / 4 kV / 3;
- > to assign a larger current-carrying capacity, both due to the lower contact resistance (1 mΩ instead of 3 mΩ) and the larger wire size available for series CC compared with series CD contacts; to use wires with a larger cross-sectional area of 4 mm² / AWG 12, to contain the percent voltage drop [%] in circuits fed with extra-low voltage and with comparatively high currents or in circuits of considerable length;
- > to use crimp contacts with inherently higher mechanical robustness;
- > to use anticipated pin contacts CC...AN (e.g. for the remote signalling of the "OPEN" or "CLOSED" status of the connector).

FOCUS

Special voltages for CQE series

When all the contacts are used, CQE connector inserts may be used at rated voltage up to 500 V (first column) Pollution Degree 3, in accordance with the standard EN 61984. If the number of contacts is reduced and the contacts accordingly assigned, these connectors may be used at higher voltages.

This is possible because the decrease in the number of contacts leads to an increase clearances and creepage distances. When the contacts are arranged as shown below, the inserts may be used at rated voltages of 690 V (second column) and 1000 V (third column) Pollution Degree 3, in accordance with the standard EN 61984.



contacts side - front view

- working contact
- without contact
- F female insert
- M male insert

CQE 10

16 A 500 V


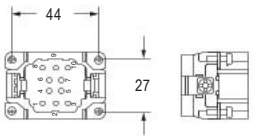
size **44.27**
10 poles + ⊕


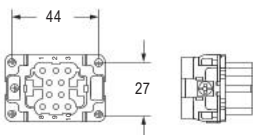
Crimp connection


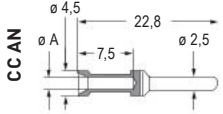

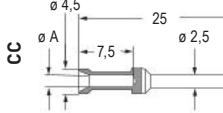

EN 61984 rating	16 A 500 V 6 kV 3
	16 A 830 V 8 kV 2
Rated voltage (UL / CSA)	600 V
Insulation resistance	≥ 10 GΩ
Contact resistance	≤ 1 mΩ
Ambient temperature limit	-40 °C ... +125 °C
Mechanical life (cycles)	≥ 500




ILME US ECBT2.E115072 | ECBT8.E115072

Item	Description	Part No.	Dimension
	Male inserts for male contacts Without contacts (to be ordered separately)	CQEM 10	

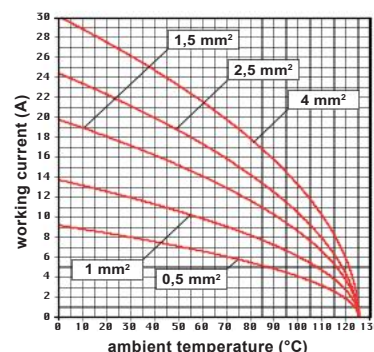
	Female inserts for female contacts Without contacts (to be ordered separately)	CQEF 10	
---	--	-------------------------	---

	16 A advanced opening contacts	Male	Female																												
	section (mm ²) section (AWG)			 CC AN																											
	0,5 20	CC 0.5 AN																													
	0,75 18	CC 0.7 AN																													
	1 18	CC 1.0 AN																													
	1,5 16	CC 1.5 AN																													
	2,5 14	CC 2.5 AN																													
	16 A crimp contacts			 CC																											
	section (mm ²) section (AWG)																														
	0,14-0,37 26-22	CCMA 0.3	CCFA 0.3	Wiring information, CC contacts <table border="1"> <thead> <tr> <th>conductor section (mm²)</th> <th>conductor slot ø A (mm)</th> <th>stripping length (mm)</th> </tr> </thead> <tbody> <tr><td>0,14-0,37</td><td>0,9</td><td>7,5</td></tr> <tr><td>0,5</td><td>1,1</td><td>7,5</td></tr> <tr><td>0,75</td><td>1,3</td><td>7,5</td></tr> <tr><td>1,0</td><td>1,45</td><td>7,5</td></tr> <tr><td>1,5</td><td>1,8</td><td>7,5</td></tr> <tr><td>2,5</td><td>2,2</td><td>7,5</td></tr> <tr><td>3,0</td><td>2,55</td><td>7,5</td></tr> <tr><td>4,0</td><td>2,85</td><td>7,5</td></tr> </tbody> </table> Wire diameter: up to 4,7 mm. For basic or high thickness gold plating, please refer to page E.13 It is recommended to use the crimping tools and removal tools homologated by ILME (please see page E.23)	conductor section (mm ²)	conductor slot ø A (mm)	stripping length (mm)	0,14-0,37	0,9	7,5	0,5	1,1	7,5	0,75	1,3	7,5	1,0	1,45	7,5	1,5	1,8	7,5	2,5	2,2	7,5	3,0	2,55	7,5	4,0	2,85	7,5
conductor section (mm ²)	conductor slot ø A (mm)	stripping length (mm)																													
0,14-0,37	0,9	7,5																													
0,5	1,1	7,5																													
0,75	1,3	7,5																													
1,0	1,45	7,5																													
1,5	1,8	7,5																													
2,5	2,2	7,5																													
3,0	2,55	7,5																													
4,0	2,85	7,5																													
	0,5 20	CCMA 0.5	CCFA 0.5																												
	0,75 18	CCMA 0.7	CCFA 0.7																												
	1 18	CCMA 1.0	CCFA 1.0																												
	1,5 16	CCMA 1.5	CCFA 1.5																												
	2,5 14	CCMA 2.5	CCFA 2.5																												
	3 12	CCMA 3.0	CCFA 3.0																												
	4 12	CCMA 4.0	CCFA 4.0																												
	0,14-0,37 26-22	CCMD 0.3	CCFD 0.3																												
	0,5 20	CCMD 0.5	CCFD 0.5																												
	0,75 18	CCMD 0.7	CCFD 0.7																												
	1 18	CCMD 1.0	CCFD 1.0																												
	1,5 16	CCMD 1.5	CCFD 1.5																												
	2,5 14	CCMD 2.5	CCFD 2.5																												
	3 12	CCMD 3.0	CCFD 3.0																												
	4 12	CCMD 4.0	CCFD 4.0																												

Materials	
Insert	polycarbonate (PC)
UL 94 flame rating	V-0
Colour	pebble grey, RAL 7032
Contacts	copper alloy, silver ● and gold ● plated

 **CR CPQ**
Coding pins
Page [E.3](#)

Enclosures size 44.27	Pages
Heavy-Duty Applications	
Metallic with C-TYPE lever	E.48-53
Metallic with IL-BRID lever	E.90-91 , 104
Metallic with JEI®-P lever	E.112 , 119
Metallic with V-TYPE IP67 lever	E.124 , 128-129
Thermoplastic T-TYPE	E.226-227 , 234-235
Aggressive Environments	
Metallic IP68 high protection	E.142-143
Metallic W-TYPE	E.154-155 , 162
Metallic E-Xtreme®	E.174-175 , 182-183 , 194
Thermoplastic T-TYPE/W	E.226-227 , 234-235
Specialized Applications	
EMC (Electromagnetic Shielding)	E.208-209 , 216
Hygienic series for food and beverage	E.244 , 248
Standard applications with Central lever	E.254-255
BIG Enclosures for multiple cable entries	E.268 , 272-273
COB system for switch cabinet	E.286-289
Light and Sound applications with JEI®-P lever	E.296-297



CQE 10 inserts max. current load derating diagram

For applications requiring higher voltages, please see the special voltage application section on page [E.71](#)

CQE 18

16 A 500 V

size **57.27**

18 poles + ⊕

Crimp connection

EN 61984 rating	16 A 500 V 6 kV 3
	16 A 830 V 8 kV 2
Rated voltage (UL / CSA)	600 V
Insulation resistance	≥ 10 GΩ
Contact resistance	≤ 1 mΩ
Ambient temperature limit	-40 °C ... +125 °C
Mechanical life (cycles)	≥ 500



ILME US ECBT2.E115072 | ECBT8.E115072

Item	Description	Part No.	Dimension
	Male inserts for male contacts Without contacts (to be ordered separately)	CQEM 18	

	Female inserts for female contacts Without contacts (to be ordered separately)	CQEF 18	
--	--	-------------------------	--

	16 A advanced opening contacts	Male	Female	
	section (mm ²) section (AWG)			
	0,5 20	CC 0.5 AN		
	0,75 18	CC 0.7 AN		
	1 18	CC 1.0 AN		
	1,5 16	CC 1.5 AN		
	2,5 14	CC 2.5 AN		
	16 A crimp contacts			
	section (mm ²) section (AWG)			
	0,14-0,37 26-22	CCMA 0.3	CCFA 0.3	
	0,5 20	CCMA 0.5	CCFA 0.5	
	0,75 18	CCMA 0.7	CCFA 0.7	
	1 18	CCMA 1.0	CCFA 1.0	
	1,5 16	CCMA 1.5	CCFA 1.5	
	2,5 14	CCMA 2.5	CCFA 2.5	
	3 12	CCMA 3.0	CCFA 3.0	
	4 12	CCMA 4.0	CCFA 4.0	
	0,14-0,37 26-22	CCMD 0.3	CCFD 0.3	
	0,5 20	CCMD 0.5	CCFD 0.5	
	0,75 18	CCMD 0.7	CCFD 0.7	
	1 18	CCMD 1.0	CCFD 1.0	
	1,5 16	CCMD 1.5	CCFD 1.5	
	2,5 14	CCMD 2.5	CCFD 2.5	
	3 12	CCMD 3.0	CCFD 3.0	
	4 12	CCMD 4.0	CCFD 4.0	

Wiring information, CC contacts

conductor section (mm ²)	conductor slot ø A (mm)	stripping length (mm)
0,14-0,37	0,9	7,5
0,5	1,1	7,5
0,75	1,3	7,5
1,0	1,45	7,5
1,5	1,8	7,5
2,5	2,2	7,5
3,0	2,55	7,5
4,0	2,85	7,5

Wire diameter: up to 4,7 mm.

For basic or high thickness gold plating, please refer to page [E.13](#).

It is recommended to use the crimping tools and removal tools homologated by ILME (please see page [E.23](#)).

Materials

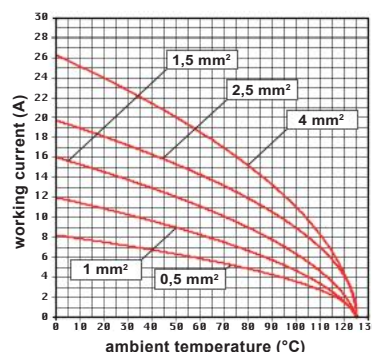
Insert	polycarbonate (PC)
UL 94 flame rating	V-0
Colour	pebble grey, RAL 7032
Contacts	copper alloy, silver ● and gold ● plated

CR CPQ
Coding pins
Page [E.3](#)

Enclosures size 57.27

Pages

Heavy-Duty Applications	Pages
Metallic with C-TYPE lever	E.54-61
Metallic with IL-BRID lever	E.92-95 , 105
Metallic with JEI®-P lever	E.113-114 , 119
Metallic with V-TYPE IP67 lever	E.125 , 130-131
Thermoplastic T-TYPE	E.228-229 , 234-235
Aggressive Environments	
Metallic IP68 high protection	E.144-145
Metallic W-TYPE	E.156-157 , 163
Metallic E-Xtreme®	E.176-177 , 184-185 , 195
Thermoplastic T-TYPE/W	E.228-229 , 234-235
Specialized Applications	
EMC (Electromagnetic Shielding)	E.210-211 , 217
Hygienic series for food and beverage	E.245 , 248
Standard applications with Central lever	E.256-257
BIG Enclosures for multiple cable entries	E.269 , 274-275
COB system for switch cabinet	E.286-289
Light and Sound applications with JEI®-P lever	E.298-299



CQE 18 inserts max. current load derating diagram

For applications requiring higher voltages, please see the special voltage application section on page [E.71](#).

CQE 32

16 A 500 V

size **77.27**

32 poles + ⊕

Crimp connection

EN 61984 rating	16 A 500 V 6 kV 3
	16 A 830 V 8 kV 2
Rated voltage (UL / CSA)	600 V
Insulation resistance	≥ 10 GΩ
Contact resistance	≤ 1 mΩ
Ambient temperature limit	-40 °C ... +125 °C
Mechanical life (cycles)	≥ 500

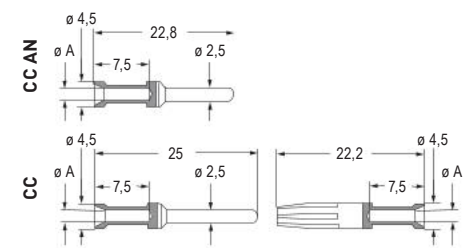


ILME US ECBT2.E115072 | ECBT8.E115072

Item	Description	Part No.	Dimension
	Male inserts for male contacts Without contacts (to be ordered separately)	CQEM 32	

	Female inserts for female contacts Without contacts (to be ordered separately)	CQEF 32	
--	--	-------------------------	--

16 A advanced opening contacts	section (mm ²)		section (AWG)		Male	Female
		0,14-0,37	0,5	20	CC 0.5 AN	CCAN 0.5
	0,5	0,75	18	CC 0.7 AN	CCAN 0.7	
	0,75	1	18	CC 1.0 AN	CCAN 1.0	
	1	1,5	16	CC 1.5 AN	CCAN 1.5	
	1,5	2,5	14	CC 2.5 AN	CCAN 2.5	
	2,5					
16 A crimp contacts	section (mm ²)		section (AWG)		Male	Female
		0,14-0,37	0,5	20	CCMA 0.3	CCFA 0.3
	0,5	0,75	18	CCMA 0.5	CCFA 0.5	
	0,75	1	18	CCMA 0.7	CCFA 0.7	
	1	1,5	16	CCMA 1.0	CCFA 1.0	
	1,5	2,5	14	CCMA 1.5	CCFA 1.5	
	2,5	3	12	CCMA 2.5	CCFA 2.5	
	3	4	12	CCMA 3.0	CCFA 3.0	
	4			CCMA 4.0	CCFA 4.0	
	0,14-0,37	0,5	20	CCMD 0.3	CCFD 0.3	
	0,5	0,75	18	CCMD 0.5	CCFD 0.5	
	0,75	1	18	CCMD 0.7	CCFD 0.7	
	1	1,5	16	CCMD 1.0	CCFD 1.0	
	1,5	2,5	14	CCMD 1.5	CCFD 1.5	
	2,5	3	12	CCMD 2.5	CCFD 2.5	
	3	4	12	CCMD 3.0	CCFD 3.0	
	4			CCMD 4.0	CCFD 4.0	



Wiring information, CC contacts

conductor section (mm ²)	conductor slot ø A (mm)	stripping length (mm)
0,14-0,37	0,9	7,5
0,5	1,1	7,5
0,75	1,3	7,5
1,0	1,45	7,5
1,5	1,8	7,5
2,5	2,2	7,5
3,0	2,55	7,5
4,0	2,85	7,5

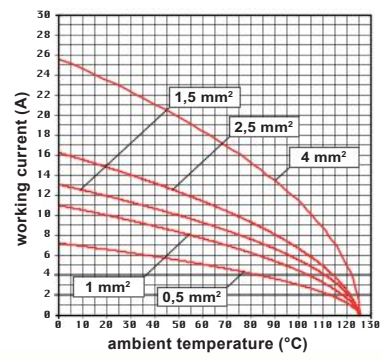
Wire diameter: up to 4,7 mm.
For basic or high thickness gold plating, please refer to page [E.13](#)
It is recommended to use the crimping tools and removal tools homologated by ILME (please see page [E.23](#))

Materials

Insert	polycarbonate (PC)
UL 94 flame rating	V-0
Colour	pebble grey, RAL 7032
Contacts	copper alloy, silver ● and gold ● plated

CR CPQ
Coding pins
Page [E.3](#)

Enclosures size 77.27	Pages
Heavy-Duty Applications	
Metallic with C-TYPE lever	E.62-69
Metallic with IL-BRID lever	E.96-99 , 106
Metallic with JEI®-P lever	E.115-116 , 119
Metallic with V-TYPE IP67 lever	E.126 , 132-133
Thermoplastic T-TYPE	E.230-231 , 234-235
Aggressive Environments	
Metallic IP68 high protection	E.146-147
Metallic W-TYPE	E.158-159 , 164
Metallic E-Xtreme®	E.178-179 , 186-187 , 196
Thermoplastic T-TYPE/W	E.230-231 , 234-235
Specialized Applications	
EMC (Electromagnetic Shielding)	E.212-213 , 218
Hygienic series for food and beverage	E.246 , 248
Standard applications with Central lever	E.258-259
BIG Enclosures for multiple cable entries	E.270 , 276-277
COB system for switch cabinet	E.286-289
Light and Sound applications with JEI®-P lever	E.300-301



CQE 32 inserts max. current load derating diagram

For applications requiring higher voltages, please see the special voltage application section on page [E.71](#)

CQE 46

16 A 500 V

size **104.27**

46 poles + ⊕

Crimp connection

EN 61984 rating	16 A 500 V 6 kV 3
	16 A 830 V 8 kV 2
Rated voltage (UL / CSA)	600 V
Insulation resistance	≥ 10 GΩ
Contact resistance	≤ 1 mΩ
Ambient temperature limit	-40 °C ... +125 °C
Mechanical life (cycles)	≥ 500



ILME US ECBT2.E115072 | ECBT8.E115072

Item	Description	Part No.	Dimension
	Male inserts for male contacts Without contacts (to be ordered separately)	CQEM 46	

	Female inserts for female contacts Without contacts (to be ordered separately)	CQEF 46	
--	--	-------------------------	--

	16 A advanced opening contacts	Male	Female	
	section (mm ²) section (AWG)			
	0,5 20	CC 0.5 AN		
	0,75 18	CC 0.7 AN		
	1 18	CC 1.0 AN		
	1,5 16	CC 1.5 AN		
	2,5 14	CC 2.5 AN		
	16 A crimp contacts			
	section (mm ²) section (AWG)			
	0,14-0,37 26-22	CCMA 0.3	CCFA 0.3	
	0,5 20	CCMA 0.5	CCFA 0.5	
	0,75 18	CCMA 0.7	CCFA 0.7	
	1 18	CCMA 1.0	CCFA 1.0	
	1,5 16	CCMA 1.5	CCFA 1.5	
	2,5 14	CCMA 2.5	CCFA 2.5	
	3 12	CCMA 3.0	CCFA 3.0	
	4 12	CCMA 4.0	CCFA 4.0	
	0,14-0,37 26-22	CCMD 0.3	CCFD 0.3	
	0,5 20	CCMD 0.5	CCFD 0.5	
	0,75 18	CCMD 0.7	CCFD 0.7	
	1 18	CCMD 1.0	CCFD 1.0	
	1,5 16	CCMD 1.5	CCFD 1.5	
	2,5 14	CCMD 2.5	CCFD 2.5	
	3 12	CCMD 3.0	CCFD 3.0	
	4 12	CCMD 4.0	CCFD 4.0	

Wiring information, CC contacts

conductor section (mm ²)	conductor slot ø A (mm)	stripping length (mm)
0,14-0,37	0,9	7,5
0,5	1,1	7,5
0,75	1,3	7,5
1,0	1,45	7,5
1,5	1,8	7,5
2,5	2,2	7,5
3,0	2,55	7,5
4,0	2,85	7,5

Wire diameter: up to 4,7 mm.

For basic or high thickness gold plating, please refer to page [E.13](#).

It is recommended to use the crimping tools and removal tools homologated by ILME (please see page [F.23](#)).

Materials

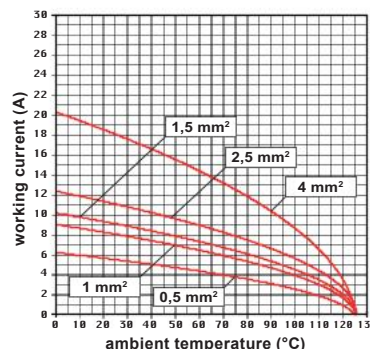
Insert	polycarbonate (PC)
UL 94 flame rating	V-0
Colour	pebble grey, RAL 7032
Contacts	copper alloy, silver ● and gold ● plated

CR CPQ
Coding pins
Page [E.3](#)

Enclosures size 104.27

Pages

Heavy-Duty Applications	Pages
Metallic with C-TYPE lever	E.70-77
Metallic with IL-BRID lever	E.100-103 107
Metallic with JEI®-P lever	E.117-119
Metallic with V-TYPE IP67 lever	E.127 134-135
Thermoplastic T-TYPE	E.232-235
Aggressive Environments	Pages
Metallic IP68 high protection	E.148-149
Metallic W-TYPE	E.160-161 165
Metallic E-Xtreme®	E.180-181 188-189 197
Thermoplastic T-TYPE/W	E.232-235
Specialized Applications	Pages
EMC (Electromagnetic Shielding)	E.214-215 219
Hygienic series for food and beverage	E.247-248
Standard applications with Central lever	E.260-261
BIG Enclosures for multiple cable entries	E.271 278-279
COB system for switch cabinet	E.286-289
Light and Sound applications with JEI®-P lever	E.302-303



CQE 46 inserts max. current load derating diagram

For applications requiring higher voltages, please see the special voltage application section on [E.71](#)

CQE 32 + CQE 32 N

16 A 500 V

size **77.62**

64 poles +

Crimp connection

EN 61984 rating	16 A 500 V 6 kV 3
	16 A 830 V 8 kV 2
Rated voltage (UL / CSA)	600 V
Insulation resistance	≥ 10 GΩ
Contact resistance	≤ 1 mΩ
Ambient temperature limit	-40 °C ... +125 °C
Mechanical life (cycles)	≥ 500



ILME® US ECBT2.E115072 | ECBT8.E115072

Item	Description	Part No.	Dimension
	Male inserts, No. (1-32) Male inserts, No. (33-64) Without contacts (to be ordered separately)	CQEM 32 CQEM 32 N	

	Female inserts, No. (1-32) Female inserts, No. (33-64) Without contacts (to be ordered separately)	CQEF 32 CQEF 32 N	
--	---	--	--

CQE
B

	16 A advanced opening contacts	Male	Female																												
	section (mm ²) section (AWG)			 																											
	0,5 20 0,75 18 1 18 1,5 16 2,5 14	CC 0.5 AN CC 0.7 AN CC 1.0 AN CC 1.5 AN CC 2.5 AN																													
	16 A crimp contacts			Wiring information, CC contacts <table border="1"> <thead> <tr> <th>conductor section (mm²)</th> <th>conductor slot ø A (mm)</th> <th>stripping length (mm)</th> </tr> </thead> <tbody> <tr><td>0,14-0,37</td><td>0,9</td><td>7,5</td></tr> <tr><td>0,5</td><td>1,1</td><td>7,5</td></tr> <tr><td>0,75</td><td>1,3</td><td>7,5</td></tr> <tr><td>1,0</td><td>1,45</td><td>7,5</td></tr> <tr><td>1,5</td><td>1,8</td><td>7,5</td></tr> <tr><td>2,5</td><td>2,2</td><td>7,5</td></tr> <tr><td>3,0</td><td>2,55</td><td>7,5</td></tr> <tr><td>4,0</td><td>2,85</td><td>7,5</td></tr> </tbody> </table>	conductor section (mm ²)	conductor slot ø A (mm)	stripping length (mm)	0,14-0,37	0,9	7,5	0,5	1,1	7,5	0,75	1,3	7,5	1,0	1,45	7,5	1,5	1,8	7,5	2,5	2,2	7,5	3,0	2,55	7,5	4,0	2,85	7,5
conductor section (mm ²)	conductor slot ø A (mm)	stripping length (mm)																													
0,14-0,37	0,9	7,5																													
0,5	1,1	7,5																													
0,75	1,3	7,5																													
1,0	1,45	7,5																													
1,5	1,8	7,5																													
2,5	2,2	7,5																													
3,0	2,55	7,5																													
4,0	2,85	7,5																													
	section (mm ²) section (AWG)																														
	0,14-0,37 26-22 0,5 20 0,75 18 1 18 1,5 16 2,5 14 3 12 4 12	CCMA 0.3 CCMA 0.5 CCMA 0.7 CCMA 1.0 CCMA 1.5 CCMA 2.5 CCMA 3.0 CCMA 4.0	CCFA 0.3 CCFA 0.5 CCFA 0.7 CCFA 1.0 CCFA 1.5 CCFA 2.5 CCFA 3.0 CCFA 4.0																												
	0,14-0,37 26-22 0,5 20 0,75 18 1 18 1,5 16 2,5 14 3 12 4 12	CCMD 0.3 CCMD 0.5 CCMD 0.7 CCMD 1.0 CCMD 1.5 CCMD 2.5 CCMD 3.0 CCMD 4.0	CCFD 0.3 CCFD 0.5 CCFD 0.7 CCFD 1.0 CCFD 1.5 CCFD 2.5 CCFD 3.0 CCFD 4.0																												

Wire diameter: up to 4,7 mm.

For basic or high thickness gold plating, please refer to page [E.13](#)

It is recommended to use the crimping tools and removal tools homologated by ILME (please see page [E.23](#))

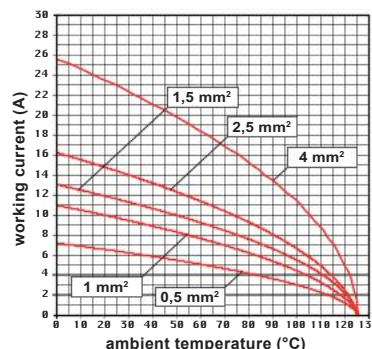
Materials

Insert	polycarbonate (PC)
UL 94 flame rating	V-0
Colour	pebble grey, RAL 7032
Contacts	copper alloy, silver ● and gold ● plated



CR CPQ
Coding pins
Page [E.3](#)

Enclosures size 77.62	Pages
Heavy-Duty Applications	
Metallic with C-TYPE lever	E.78-83
Aggressive Environments	
Metallic W-TYPE with C-TYPE lever	E.166-167
Metallic E-Xtreme® with C-TYPE lever	E.190-191



CQE 32 inserts max. current load derating diagram

For applications requiring higher voltages, please see the special voltage application section on page [E.71](#)

CQE 46 + CQE 46 N

16 A 500 V

size **104.62**

92 poles +

Crimp connection

EN 61984 rating	16 A 500 V 6 kV 3
	16 A 830 V 8 kV 2
Rated voltage (UL / CSA)	600 V
Insulation resistance	≥ 10 GΩ
Contact resistance	≤ 1 mΩ
Ambient temperature limit	-40 °C ... +125 °C
Mechanical life (cycles)	≥ 500



ALUS ECBT2.E115072 | ECBT8.E115072

Item	Description	Part No.	Dimension
	Male inserts, No. (1-46) Male inserts, No. (47-92) Without contacts (to be ordered separately)	CQEM 46 CQEM 46 N	

	Female inserts, No. (1-46) Female inserts, No. (47-92) Without contacts (to be ordered separately)	CQEF 46 CQEF 46 N	
--	---	--	--

16 A advanced opening contacts		Male	Female	
section (mm ²)	section (AWG)			
0,5	20	CC 0.5 AN		
0,75	18	CC 0.7 AN		
1	18	CC 1.0 AN		
1,5	16	CC 1.5 AN		
2,5	14	CC 2.5 AN		
		silver		
16 A crimp contacts				
section (mm ²)	section (AWG)			
0,14-0,37	26-22	CCMA 0.3	CCFA 0.3	
0,5	20	CCMA 0.5	CCFA 0.5	
0,75	18	CCMA 0.7	CCFA 0.7	
1	18	CCMA 1.0	CCFA 1.0	
1,5	16	CCMA 1.5	CCFA 1.5	
2,5	14	CCMA 2.5	CCFA 2.5	
3	12	CCMA 3.0	CCFA 3.0	
4	12	CCMA 4.0	CCFA 4.0	
		silver		
0,14-0,37	26-22	CCMD 0.3	CCFD 0.3	
0,5	20	CCMD 0.5	CCFD 0.5	
0,75	18	CCMD 0.7	CCFD 0.7	
1	18	CCMD 1.0	CCFD 1.0	
1,5	16	CCMD 1.5	CCFD 1.5	
2,5	14	CCMD 2.5	CCFD 2.5	
3	12	CCMD 3.0	CCFD 3.0	
4	12	CCMD 4.0	CCFD 4.0	
		gold		

Wiring information, CC contacts

conductor section (mm ²)	conductor slot ø A (mm)	stripping length (mm)
0,14-0,37	0,9	7,5
0,5	1,1	7,5
0,75	1,3	7,5
1,0	1,45	7,5
1,5	1,8	7,5
2,5	2,2	7,5
3,0	2,55	7,5
4,0	2,85	7,5

Wire diameter: up to 4,7 mm.

For basic or high thickness gold plating, please refer to page [E.13](#).

It is recommended to use the crimping tools and removal tools homologated by ILME (please see page [E.23](#))

Materials

Insert	polycarbonate (PC)
UL 94 flame rating	V-0
Colour	pebble grey, RAL 7032
Contacts	copper alloy, silver ● and gold ● plated

CR CPQ
Coding pins
Page [E.3](#)

Enclosures size 104.62

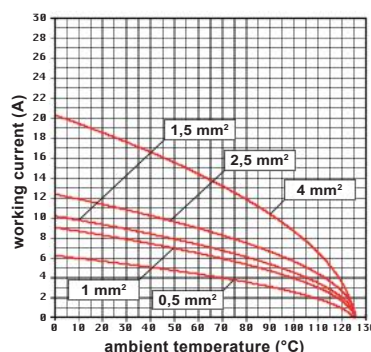
Pages [E.84-E.85](#)

Heavy-Duty Applications

Metallic with C-TYPE lever	E.84-85
----------------------------	-------------------------

Aggressive Environments

Metallic W-TYPE with C-TYPE lever	E.168-169
Metallic E-Xtreme® with C-TYPE lever	E.192-193



CQE 46 inserts max. current load derating diagram

For applications requiring higher voltages, please see the special voltage application section on [E.71](#)

CQEE 40

16 A 500 V

size **77.27**


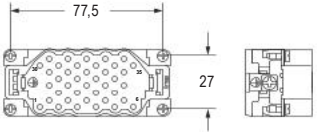
40 poles + ⊕

Crimp connection

EN 61984 rating	16 A 500 V 6 kV 3
Rated voltage (UL / CSA)	600 V
Insulation resistance	≥ 10 GΩ
Contact resistance	≤ 1 mΩ
Ambient temperature limit	-40 °C ... +125 °C
Mechanical life (cycles)	≥ 500



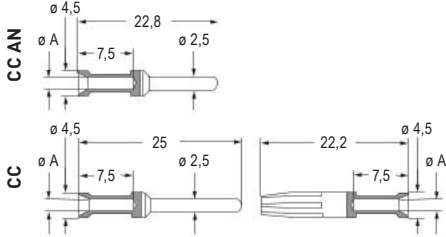
ILME US ECBT2.E115072 | ECBT8.E115072

Item	Description	Part No.	Dimension
	Male inserts for male contacts Without contacts (to be ordered separately)	CQEEM 40	

	Female inserts for female contacts Without contacts (to be ordered separately)	CQEEF 40	
---	--	--------------------------	---

CQEE

B

16 A advanced opening contacts		Male	Female																												
section (mm ²)	section (AWG)																														
0,5	20	CC 0.5 AN																													
0,75	18	CC 0.7 AN																													
1	18	CC 1.0 AN																													
1,5	16	CC 1.5 AN																													
2,5	14	CC 2.5 AN																													
16 A crimp contacts				Wiring information, CC contacts <table border="1"> <thead> <tr> <th>conductor section (mm²)</th> <th>conductor slot ø A (mm)</th> <th>stripping length (mm)</th> </tr> </thead> <tbody> <tr><td>0,14-0,37</td><td>0,9</td><td>7,5</td></tr> <tr><td>0,5</td><td>1,1</td><td>7,5</td></tr> <tr><td>0,75</td><td>1,3</td><td>7,5</td></tr> <tr><td>1,0</td><td>1,45</td><td>7,5</td></tr> <tr><td>1,5</td><td>1,8</td><td>7,5</td></tr> <tr><td>2,5</td><td>2,2</td><td>7,5</td></tr> <tr><td>3,0</td><td>2,55</td><td>7,5</td></tr> <tr><td>4,0</td><td>2,85</td><td>7,5</td></tr> </tbody> </table>	conductor section (mm ²)	conductor slot ø A (mm)	stripping length (mm)	0,14-0,37	0,9	7,5	0,5	1,1	7,5	0,75	1,3	7,5	1,0	1,45	7,5	1,5	1,8	7,5	2,5	2,2	7,5	3,0	2,55	7,5	4,0	2,85	7,5
conductor section (mm ²)	conductor slot ø A (mm)	stripping length (mm)																													
0,14-0,37	0,9	7,5																													
0,5	1,1	7,5																													
0,75	1,3	7,5																													
1,0	1,45	7,5																													
1,5	1,8	7,5																													
2,5	2,2	7,5																													
3,0	2,55	7,5																													
4,0	2,85	7,5																													
section (mm ²)	section (AWG)																														
0,14-0,37	26-22	CCMA 0.3	CCFA 0.3																												
0,5	20	CCMA 0.5	CCFA 0.5																												
0,75	18	CCMA 0.7	CCFA 0.7																												
1	18	CCMA 1.0	CCFA 1.0																												
1,5	16	CCMA 1.5	CCFA 1.5																												
2,5	14	CCMA 2.5	CCFA 2.5																												
3	12	CCMA 3.0	CCFA 3.0																												
4	12	CCMA 4.0	CCFA 4.0																												
0,14-0,37	26-22	CCMD 0.3	CCFD 0.3																												
0,5	20	CCMD 0.5	CCFD 0.5																												
0,75	18	CCMD 0.7	CCFD 0.7																												
1	18	CCMD 1.0	CCFD 1.0																												
1,5	16	CCMD 1.5	CCFD 1.5																												
2,5	14	CCMD 2.5	CCFD 2.5																												
3	12	CCMD 3.0	CCFD 3.0																												
4	12	CCMD 4.0	CCFD 4.0																												

Wire diameter: up to 4,7 mm.


For basic or high thickness gold plating, please refer to page [E.13](#)

It is recommended to use the crimping tools and removal tools homologated by ILME (please see page [E.23](#))

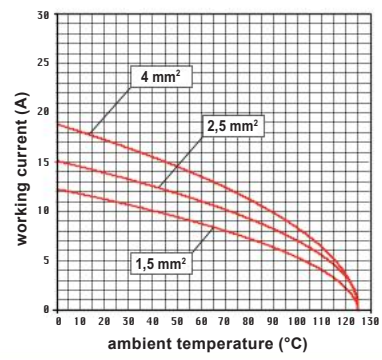
Materials

Insert	polycarbonate (PC)
UL 94 flame rating	V-0
Colour	pebble grey, RAL 7032
Contacts	copper alloy, silver ● and gold ● plated

CR CPQ
Coding pins
Page [E.3](#)



Enclosures size 77.27	Pages
Heavy-Duty Applications	
Metallic with C-TYPE lever	E.62-69
Metallic with IL-BRID lever	E.96-99 , 106
Metallic with JEI®-P lever	E.115-116 , 119
Metallic with V-TYPE IP67 lever	E.126 , 132-133
Thermoplastic T-TYPE	E.230-231 , 234-235
Aggressive Environments	
Metallic IP68 high protection	E.146-147
Metallic W-TYPE	E.158-159 , 164
Metallic E-Xtreme®	E.178-179 , 186-187 , 196
Thermoplastic T-TYPE/W	E.230-231 , 234-235
Specialized Applications	
EMC (Electromagnetic Shielding)	E.212-213 , 218
Hygienic series for food and beverage	E.246 , 248
Standard applications with Central lever	E.258-259
BIG Enclosures for multiple cable entries	E.270 , 276-277
COB system for switch cabinet	E.286-289
Light and Sound applications with JEI®-P lever	E.300-301



CQEE 40 inserts max. current load derating diagram

CQEE 64

16 A 500 V

size **104.27**

64 poles + ⊕

Crimp connection

EN 61984 rating	16 A 500 V 6 kV 3
Rated voltage (UL / CSA)	600 V
Insulation resistance	≥ 10 GΩ
Contact resistance	≤ 1 mΩ
Ambient temperature limit	-40 °C ... +125 °C
Mechanical life (cycles)	≥ 500



ILME US ECBT2.E115072 | ECBT8.E115072

Item	Description	Part No.	Dimension
	Male inserts for male contacts Without contacts (to be ordered separately)	CQEEM 64	

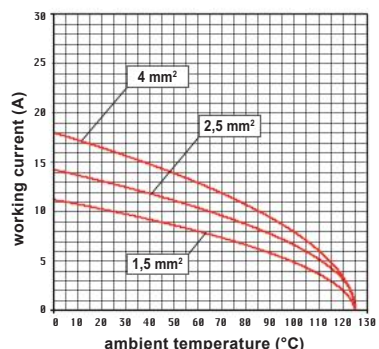
	Female inserts for female contacts Without contacts (to be ordered separately)	CQEEF 64	
--	--	--------------------------	--

	16 A advanced opening contacts	Male	Female																												
	section (mm ²) section (AWG)			 Wiring information, CC contacts <table border="1"> <thead> <tr> <th>conductor section (mm²)</th> <th>conductor slot ø A (mm)</th> <th>stripping length (mm)</th> </tr> </thead> <tbody> <tr><td>0,14-0,37</td><td>0,9</td><td>7,5</td></tr> <tr><td>0,5</td><td>1,1</td><td>7,5</td></tr> <tr><td>0,75</td><td>1,3</td><td>7,5</td></tr> <tr><td>1,0</td><td>1,45</td><td>7,5</td></tr> <tr><td>1,5</td><td>1,8</td><td>7,5</td></tr> <tr><td>2,5</td><td>2,2</td><td>7,5</td></tr> <tr><td>3,0</td><td>2,55</td><td>7,5</td></tr> <tr><td>4,0</td><td>2,85</td><td>7,5</td></tr> </tbody> </table>	conductor section (mm ²)	conductor slot ø A (mm)	stripping length (mm)	0,14-0,37	0,9	7,5	0,5	1,1	7,5	0,75	1,3	7,5	1,0	1,45	7,5	1,5	1,8	7,5	2,5	2,2	7,5	3,0	2,55	7,5	4,0	2,85	7,5
conductor section (mm ²)	conductor slot ø A (mm)	stripping length (mm)																													
0,14-0,37	0,9	7,5																													
0,5	1,1	7,5																													
0,75	1,3	7,5																													
1,0	1,45	7,5																													
1,5	1,8	7,5																													
2,5	2,2	7,5																													
3,0	2,55	7,5																													
4,0	2,85	7,5																													
0,5	20	CC 0.5 AN																													
0,75	18	CC 0.7 AN																													
1	18	CC 1.0 AN																													
1,5	16	CC 1.5 AN																													
2,5	14	CC 2.5 AN																													
	16 A crimp contacts			 																											
0,14-0,37	26-22	CCMA 0.3	CCFA 0.3																												
0,5	20	CCMA 0.5	CCFA 0.5																												
0,75	18	CCMA 0.7	CCFA 0.7																												
1	18	CCMA 1.0	CCFA 1.0																												
1,5	16	CCMA 1.5	CCFA 1.5																												
2,5	14	CCMA 2.5	CCFA 2.5																												
3	12	CCMA 3.0	CCFA 3.0																												
4	12	CCMA 4.0	CCFA 4.0																												
	0,14-0,37	26-22	CCMD 0.3		CCFD 0.3																										
0,5	20	CCMD 0.5	CCFD 0.5																												
0,75	18	CCMD 0.7	CCFD 0.7																												
1	18	CCMD 1.0	CCFD 1.0																												
1,5	16	CCMD 1.5	CCFD 1.5																												
2,5	14	CCMD 2.5	CCFD 2.5																												
3	12	CCMD 3.0	CCFD 3.0																												
4	12	CCMD 4.0	CCFD 4.0																												

Materials	
Insert	polycarbonate (PC)
UL 94 flame rating	V-0
Colour	pebble grey, RAL 7032
Contacts	copper alloy, silver ● and gold ● plated

CR CPQ
Coding pins
Page [3.3](#)

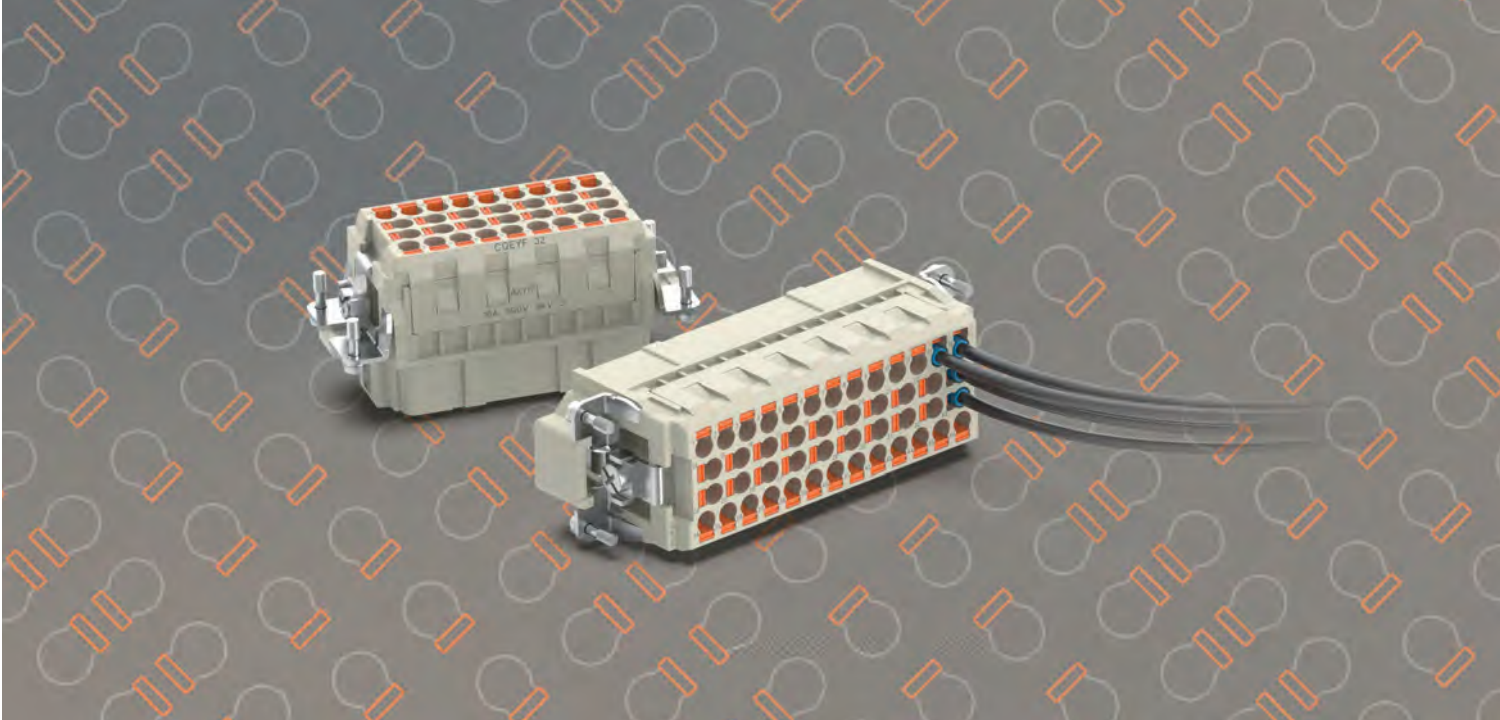
Enclosures size 104.27	Pages
Heavy-Duty Applications	
Metallic with C-TYPE lever	E.70-77
Metallic with IL-BRID lever	E.100-103 107
Metallic with JEI®-P lever	E.117-119
Metallic with V-TYPE IP67 lever	E.127 134-135
Thermoplastic T-TYPE	E.232-235
Aggressive Environments	
Metallic IP68 high protection	E.148-149
Metallic W-TYPE	E.160-161 165
Metallic E-Xtreme®	E.180-181 188-189 197
Thermoplastic T-TYPE/W	E.232-235
Specialized Applications	
EMC (Electromagnetic Shielding)	E.214-215 219
Hygienic series for food and beverage	E.247-248
Standard applications with Central lever	E.260-261
BIG Enclosures for multiple cable entries	E.271 278-279
COB system for switch cabinet	E.286-289
Light and Sound applications with JEI®-P lever	E.302-303



CQEE 64 inserts max. current load derating diagram

CQEY - AXYR® series

Connection without tools. High contacts density.



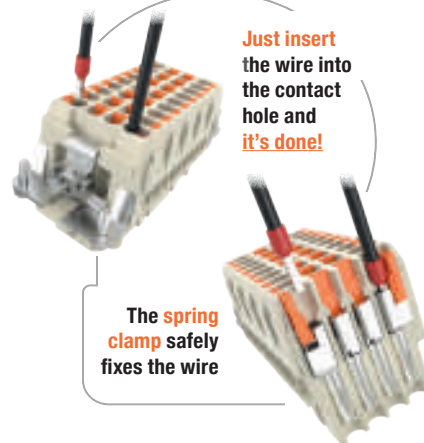
CQEY series overview

The 16 A range of connector inserts using the **AXYR®** tool-less technology is furtherly widened by the new **CQEY** series intermateable with the corresponding available models of **CQE** series (crimp).

The **AXYR®** technology can equal the crimp connectors versions in terms of high density without requiring any crimping tool.

TECHNOLOGY
AT A GLANCE

AXYR®





Watch our clip



CQEY series

B

FOCUS

Inserts' technology

The **AXYR**[®] 16 A tool-less spring push-in contacts cover a wiring range: 0,25 mm² to 2,5 mm² (AWG 24-14) for prepared wires; 0,25 mm² to 4 mm² (AWG 24-12) for unprepared wires.

The performance of a mixed **CQEY / CQE coupling** is equivalent to that of an equivalent unmixed (CQE / CQE or CQEY / CQEY) coupling where both sides are wired with the lowest of the wire sizes used by the mixed coupling.

The inserts of **AXYR**[®] series CQEY are available in standard and double-insert sizes like for CQE series.

CQEY connector inserts allow additional coding of the mating face by means of **CR Q08E** coding pins, that must be fitted in the dedicated dovetail shaped seats on the contour of the mating face in specular pattern.



► High contacts density



► Required pins to correctly code a coupling:

- 3 pins for 10 and 18 poles connectors
- 4 pins for 32, 46, 64 and 92 poles connectors

► CR Q08E optional plastic coding pins for up to 6 configurations

CQEY 10

16 A 500 V

size **44.27**

10 poles + ⊕


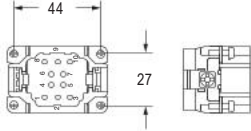

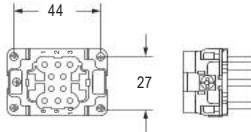
Tool-less connection – AXYR®

EN 61984 rating	16 A 500 V 6 kV 3
	16 A 830 V 8 kV 2
Rated voltage (UL / CSA)	600 V
Insulation resistance	≥ 10 GΩ
Contact resistance	≤ 3 mΩ
Ambient temperature limit	-40 °C ... +125 °C
Mechanical life (cycles)	≥ 500

CE UK (pending: EAC)

(pending: CQC, DNV and BV)

(pending: cURus)

Item	Description	Part No.	Dimension
	Male inserts with male contacts Spring/AXYR® push-in connection	CQEYM 10	
	Female inserts with female contacts Spring/AXYR® push-in connection	CQEYF 10	

Materials

Insert	polycarbonate (PC)
UL 94 flame rating	V-0
Colour	pebble grey, RAL 7032
Contacts	built-in, copper alloy, silver ● plated

Wiring information

Wire cross sectional area	0,25 mm ² - 4 mm ² (AWG 24-12)
- unprepared	0,25 mm ² - 2,5 mm ² (AWG 24-14)
- prepared	9...11 mm
Stripping length	

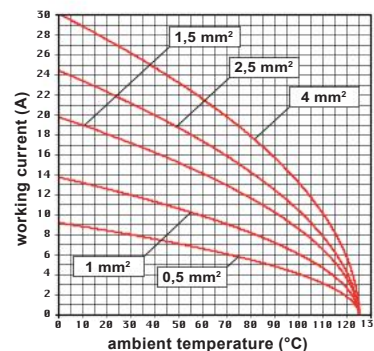
Wire diameter: up to 5 mm.



CR Q08E
Coding pins
Page [6.8](#)

Enclosures size 44.27

Heavy-Duty Applications	Pages
Metallic with C-TYPE lever	E.48-53
Metallic with IL-BRID lever	E.90-91, 104
Metallic with JEI®-P lever	E.112, 119
Metallic with V-TYPE IP67 lever	E.124, 128-129
Thermoplastic T-TYPE	E.226-227, 234-235
Aggressive Environments	
Metallic IP68 high protection	E.142-143
Metallic W-TYPE	E.154-155, 162
Metallic E-Xtreme®	E.174-175, 182-183, 194
Thermoplastic T-TYPE/W	E.226-227, 234-235
Specialized Applications	
EMC (Electromagnetic Shielding)	E.208-209, 216
Hygienic series for food and beverage	E.244, 248
Standard applications with Central lever	E.254-255
BIG Enclosures for multiple cable entries	E.268, 272-273
COB system for switch cabinet	E.286-289
Light and Sound applications with JEI®-P lever	E.296-297



CQEY 10 inserts max. current load derating diagram

CQEY 18

16 A 500 V

size **57.27**

18 poles + ⊕


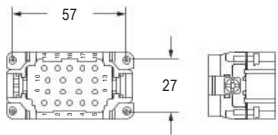

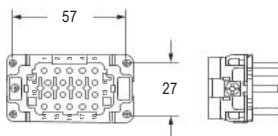
Tool-less connection – AXYR®

EN 61984 rating	16 A 500 V 6 kV 3
	16 A 830 V 8 kV 2
Rated voltage (UL / CSA)	600 V
Insulation resistance	≥ 10 GΩ
Contact resistance	≤ 3 mΩ
Ambient temperature limit	-40 °C ... +125 °C
Mechanical life (cycles)	≥ 500

CE UK (pending: EAC)

(pending: CQC, DNV and BV)

(pending: cURus)

Item	Description	Part No.	Dimension
	Male inserts with male contacts Spring/AXYR® push-in connection	CQEYM 18	
	Female inserts with female contacts Spring/AXYR® push-in connection	CQEYF 18	

Materials

Insert	polycarbonate (PC)
UL 94 flame rating	V-0
Colour	pebble grey, RAL 7032
Contacts	built-in, copper alloy, silver ● plated

Wiring information

Wire cross sectional area	0,25 mm ² - 4 mm ² (AWG 24-12)
- unprepared	0,25 mm ² - 2,5 mm ² (AWG 24-14)
- prepared	0,25 mm ² - 2,5 mm ² (AWG 24-14)
Stripping length	9...11 mm

Wire diameter: up to 5 mm.



CR Q08E
Coding pins
Page [6.8](#)

Enclosures size 57.27

Pages

Heavy-Duty Applications

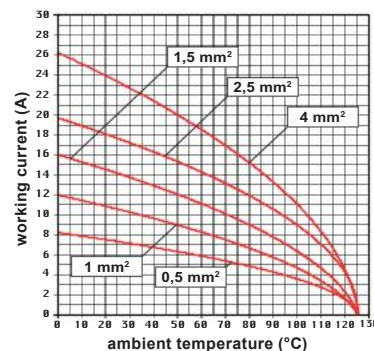
Metallic with C-TYPE lever	54-61
Metallic with IL-BRID lever	92-96 105
Metallic with JEI®-P lever	113-114 119
Metallic with V-TYPE IP67 lever	125 130-131
Thermoplastic T-TYPE	228-229 234-235

Aggressive Environments

Metallic IP68 high protection	144-145
Metallic W-TYPE	156-157 163
Metallic E-Xtreme®	176-177 184-185 193
Thermoplastic T-TYPE/W	228-229 234-235

Specialized Applications

EMC (Electromagnetic Shielding)	210-211 217
Hygienic series for food and beverage	243 248
Standard applications with Central lever	256-257
BIG Enclosures for multiple cable entries	269 274-275
COB system for switch cabinet	286-289
Light and Sound applications with JEI®-P lever	298-299



CQEY 18 inserts max. current load derating diagram

CQEY 32

16 A 500 V

size **77.27**

32 poles + ⊕


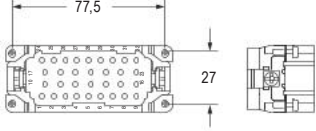

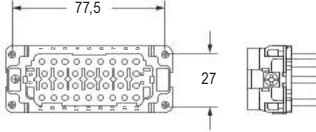
Tool-less connection – AXYR®

EN 61984 rating	16 A 500 V 6 kV 3
	16 A 830 V 8 kV 2
Rated voltage (UL / CSA)	600 V
Insulation resistance	≥ 10 GΩ
Contact resistance	≤ 3 mΩ
Ambient temperature limit	-40 °C ... +125 °C
Mechanical life (cycles)	≥ 500

CE UK (pending: EAC)

(pending: CQC, DNV and BV)

(pending: cURus)

Item	Description	Part No.	Dimension
	Male inserts with male contacts Spring/AXYR® push-in connection	CQEYM 32	
	Female inserts with female contacts Spring/AXYR® push-in connection	CQEYF 32	

Materials

Insert	polycarbonate (PC)
UL 94 flame rating	V-0
Colour	pebble grey, RAL 7032
Contacts	built-in, copper alloy, silver ● plated

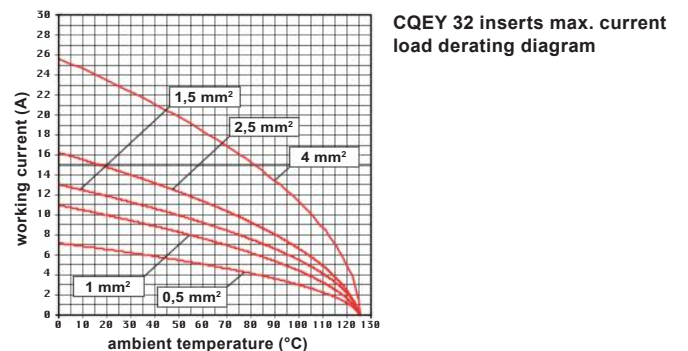
Wiring information

Wire cross sectional area	0,25 mm ² - 4 mm ² (AWG 24-12)
- unprepared	0,25 mm ² - 2,5 mm ² (AWG 24-14)
- prepared	9...11 mm
Stripping length	

Wire diameter: up to 5 mm.

CR Q08E
Coding pins
Page [6.8](#)

Enclosures size 77.27	Pages
Heavy-Duty Applications	
Metallic with C-TYPE lever	E.62-69
Metallic with IL-BRID lever	E.96-99, 106
Metallic with JEI®-P lever	E.115-116, 119
Metallic with V-TYPE IP67 lever	E.126, 132-133
Thermoplastic T-TYPE	E.230-231, 234-235
Aggressive Environments	
Metallic IP68 high protection	E.146-147
Metallic W-TYPE	E.158-159, 164
Metallic E-Xtreme®	E.178-179, 186-187, 196
Thermoplastic T-TYPE/W	E.230-231, 234-235
Specialized Applications	
EMC (Electromagnetic Shielding)	E.212-213, 218
Hygienic series for food and beverage	E.246, 248
Standard applications with Central lever	E.258-259
BIG Enclosures for multiple cable entries	E.270, 276-277
COB system for switch cabinet	E.286-289
Light and Sound applications with JEI®-P lever	E.300-301



CQEY 46

16 A 500 V

size **104.27**

46 poles + ⊕


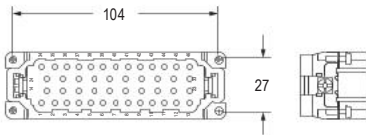

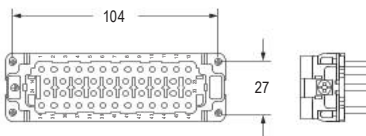
Tool-less connection – AXYR®

EN 61984 rating	16 A 500 V 6 kV 3
	16 A 830 V 8 kV 2
Rated voltage (UL / CSA)	600 V
Insulation resistance	≥ 10 GΩ
Contact resistance	≤ 3 mΩ
Ambient temperature limit	-40 °C ... +125 °C
Mechanical life (cycles)	≥ 500

CE UK (pending: EAC)

(pending: CQC, DNV and BV)

(pending: cURus)

Item	Description	Part No.	Dimension
	Male inserts with male contacts Spring/AXYR® push-in connection	CQEYM 46	
	Female inserts with female contacts Spring/AXYR® push-in connection	CQEYF 46	

Materials

Insert	polycarbonate (PC)
UL 94 flame rating	V-0
Colour	pebble grey, RAL 7032
Contacts	built-in, copper alloy, silver ● plated

Wiring information

Wire cross sectional area	0,25 mm ² - 4 mm ² (AWG 24-12)
- unprepared	0,25 mm ² - 2,5 mm ² (AWG 24-14)
- prepared	0,25 mm ² - 2,5 mm ² (AWG 24-14)
Stripping length	9...11 mm

Wire diameter: up to 5 mm.



CR Q08E
Coding pins
Page [6.8](#)

Enclosures size 104.27

Pages

Heavy-Duty Applications

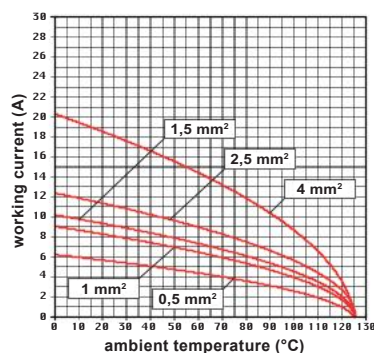
Metallic with C-TYPE lever	E.70-77
Metallic with IL-BRID lever	E.100-103 107
Metallic with JEI®-P lever	E.117-119
Metallic with V-TYPE IP67 lever	E.127 134-135
Thermoplastic T-TYPE	E.232-235

Aggressive Environments

Metallic IP68 high protection	E.148-149
Metallic W-TYPE	E.160-161 165
Metallic E-Xtreme®	E.180-181 188-189 197
Thermoplastic T-TYPE/W	E.232-235

Specialized Applications

EMC (Electromagnetic Shielding)	E.214-215 219
Hygienic series for food and beverage	E.247-248
Standard applications with Central lever	E.260-261
BIG Enclosures for multiple cable entries	E.271 278-279
COB system for switch cabinet	E.286-289
Light and Sound applications with JEI®-P lever	E.302-303



CQEY 46 inserts max. current load derating diagram



CQEY 32 + CQEY 32 N

16 A 500 V

size **77.62**

64 poles + ⊕


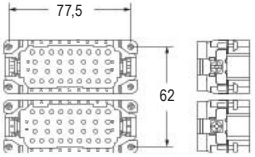

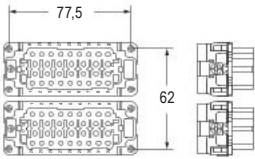
Tool-less connection – AXYR®

EN 61984 rating	16 A 500 V 6 kV 3
	16 A 830 V 8 kV 2
Rated voltage (UL / CSA)	600 V
Insulation resistance	≥ 10 GΩ
Contact resistance	≤ 3 mΩ
Ambient temperature limit	-40 °C ... +125 °C
Mechanical life (cycles)	≥ 500

CE UK (pending: EAC)

(pending: CQC, DNV and BV)

(pending: cURus)

Item	Description	Part No.	Dimension
	Male inserts, No. (1-32) Male inserts, No. (33-64) Spring/AXYR® push-in connection	CQEYM 32 CQEYM 32 N	
	Female inserts, No. (1-32) Female inserts, No. (33-64) Spring/AXYR® push-in connection	CQEYF 32 CQEYF 32 N	

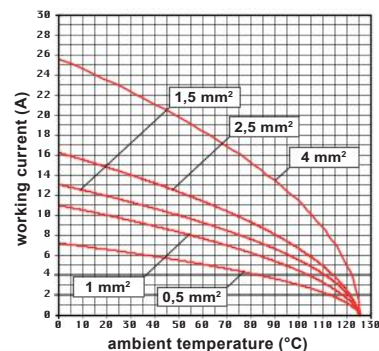
Materials

Insert	polycarbonate (PC)
UL 94 flame rating	V-0
Colour	pebble grey, RAL 7032
Contacts	built-in, copper alloy, silver ● plated

Wiring information

Wire cross sectional area	
- unprepared	0,25 mm ² - 4 mm ² (AWG 24-12)
- prepared	0,25 mm ² - 2,5 mm ² (AWG 24-14)
Stripping length	9...11 mm

Wire diameter: up to 5 mm.

**CR Q08E**Coding pins
Page [5.8](#)**Enclosures size 77.62**Pages [10](#)**Heavy-Duty Applications**Metallic with C-TYPE lever [E.78-83](#)**Aggressive Environments**Metallic W-TYPE with C-TYPE lever [E.166-167](#)Metallic E-Xtreme® with C-TYPE lever [E.190-191](#)**CQEY 32 inserts max. current load derating diagram**

CQEY 46 + CQEY 46 N

16 A 500 V

size **104.62**

92 poles + \oplus

Tool-less connection – AXYR®

EN 61984 rating	16 A 500 V 6 kV 3
	16 A 830 V 8 kV 2
Rated voltage (UL / CSA)	600 V
Insulation resistance	$\geq 10 \text{ G}\Omega$
Contact resistance	$\leq 3 \text{ m}\Omega$
Ambient temperature limit	-40 °C ... +125 °C
Mechanical life (cycles)	≥ 500

(pending: EAC)

(pending: CQC, DNV and BV)

(pending: cURus)

Item	Description	Part No.	Dimension
	Male inserts, No. (1-46) Male inserts, No. (47-92) Spring/AXYR® push-in connection	CQEYM 46 CQEYM 46 N	
	Female inserts, No. (1-46) Female inserts, No. (47-92) Spring/AXYR® push-in connection	CQEYF 46 CQEYF 46 N	

CQEY

B

Materials

Insert	polycarbonate (PC)
UL 94 flame rating	V-0
Colour	pebble grey, RAL 7032
Contacts	built-in, copper alloy, silver \bullet plated

Wiring information

Wire cross sectional area	
- unprepared	0,25 mm ² - 4 mm ² (AWG 24-12)
- prepared	0,25 mm ² - 2,5 mm ² (AWG 24-14)
Stripping length	9...11 mm

Wire diameter: up to 5 mm.



CR Q08E
Coding pins
Page [G.8](#)

Enclosures size 104.62

Pages [O](#)

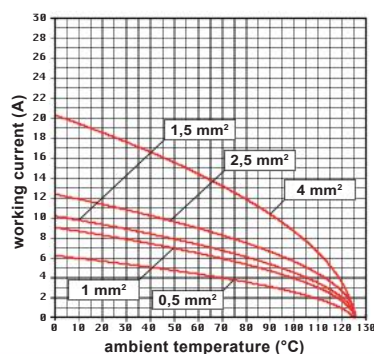
Heavy-Duty Applications

Metallic with C-TYPE lever [E.84-85](#)

Aggressive Environments

Metallic W-TYPE with C-TYPE lever [E.168-169](#)

Metallic E-Xtreme® with C-TYPE lever [E.192-193](#)



CQEY 46 inserts max. current load derating diagram

CD and CDD series

Standard sizes



CD and CDD series overview

The CD / CDD connector series has been designed for crimped connections made with removable crimp 10 A contacts, CD series.

Moreover, the CD 40 and CD 64 (together with CD 15 and CD 25, pages B.30-31) connectors are described in the EN 175301-801:2006 European standard, providing

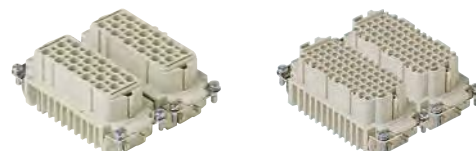
dimensional standardization for the insert geometry as well as for CD series crimp contacts and the main types (and sizes) of connector enclosures, including interface dimensions between the connector inserts and the relevant connector hood or housing, locking levers and pegs.

Single inserts versions

- > **CD 40** (40P + ⊕)
10 A 250 V 4kV 3
size 77.27
- > **CD 64** (64P + ⊕)
10 A 250 V 4kV 3
size 104.27
- > **CDD 24** (24P + ⊕)
10 A 250 V 4kV 3
high density – size 44.27
- > **CDD 42** (42P + ⊕)
10 A 250 V 4kV 3
high density – size 57.27
- > **CDD 72** (72P + ⊕)
10 A 250 V 4kV 3
high density – size 77.27
- > **CDD 108** (108P + ⊕)
10 A 250 V 4kV 3
high density – size 104.27

Double inserts versions, side by side

- > **CD 40 + CD 40**
(80P + ⊕)
10 A 250 V 4kV 3
size 77.62
- > **CD 64 + CD 64**
(128P + ⊕)
10 A 250 V 4kV 2
high density – size 104.62
- > **CDD 72 + CDD 72**
(144P + ⊕)
10 A 250 V 4kV 3
high density – size 77.62
- > **CDD 108 + CDD 108**
(216P + ⊕)
10 A 250 V 4kV 2
high density – size 104.62



FOCUS

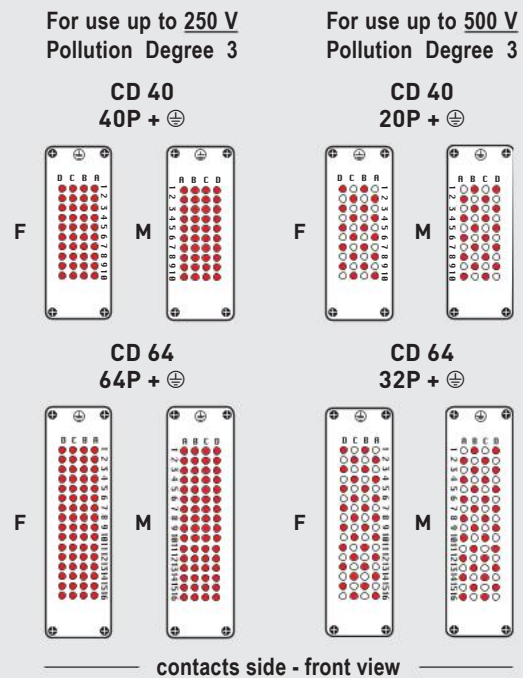
Special voltages for CD series

As for any series of connector inserts for crimped connections, the polarity is intended as "up to", always possibly fitting a connector insert with a reduced number of crimped connections, suiting the specific application. In this regard, the CD series connector inserts can be used at specific (higher) voltages.

If all the contacts are used, CD connector inserts may be used with voltage up to 250 V (first column) Pollution Degree 3 in accordance with EN 61984 standard.

If the number of contacts is reduced and the contacts assigned accordingly, these connectors may be used at 500 V (second column) Pollution Degree 3. This is possible because the decrease in the number of contacts leads to less restrictive clearances (insulating distances in air) and creepage distances (insulating distances along the surface).

- working contact F female insert
- without contact M male insert



FOCUS

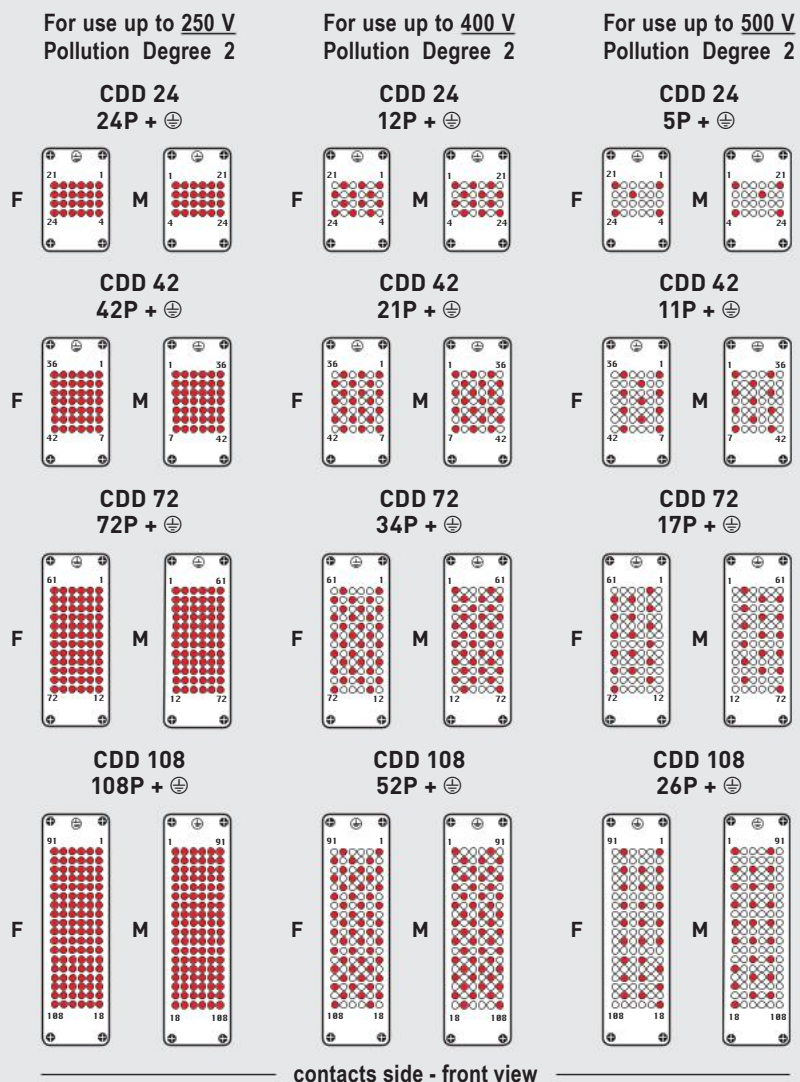
Special voltages for CDD series

When all the contacts are used, CDD series connector inserts may be used with voltage up to 250 V (first column); Pollution Degree 2, in accordance with the standard EN 61984.

If the number of contacts is reduced and the contacts assigned accordingly, these connectors may be used with higher voltages. This is possible because the decrease in the number of contacts leads to an increase in clearances (insulating distance in air) and creepage distances (insulating distances along the surface).

When the contacts are arranged as shown, the inserts may be used at rated voltages of 400 V (second column) and 500 V (third column); Pollution Degree 2, in accordance with the standard EN 61984.

- working contact F female insert
- without contact M male insert



CD 40

10 A 250 V

size **77.27**
40 poles + ⊕

Crimp connection

EN 61984 rating	10 A 250 V 4 kV 3
	10 A 230 / 400 V 4 kV 2
Rated voltage (UL / CSA)	600 V
Insulation resistance	≥ 10 GΩ
Contact resistance	≤ 3 mΩ
Ambient temperature limit	-40 °C ... +125 °C
Mechanical life (cycles)	≥ 500



ILME US ECBT2.E115072 | ECBT8.E115072

Item	Description	Part No.	Dimension
------	-------------	----------	-----------

	Male inserts for male contacts Without contacts (to be ordered separately)	CDM 40	
--	--	------------------------	--

	Female inserts for female contacts Without contacts (to be ordered separately)	CDF 40	
--	--	------------------------	--

10 A crimp contacts	section (mm ²)	section (AWG)	Male	Female	
			silver	Female	
	0,14-0,37	26-22	CDMA 0.3	CDFA 0.3	
	0,5	20	CDMA 0.5	CDFA 0.5	
	0,75	18	CDMA 0.7	CDFA 0.7	
	1	18	CDMA 1.0	CDFA 1.0	
	1,5	16	CDMA 1.5	CDFA 1.5	
	2,5	14	CDMA 2.5	CDFA 2.5	
	0,14-0,37	26-22	CDMD 0.3	CDFD 0.3	
	0,5	20	CDMD 0.5	CDFD 0.5	
	0,75	18	CDMD 0.7	CDFD 0.7	
	1	18	CDMD 1.0	CDFD 1.0	
	1,5	16	CDMD 1.5	CDFD 1.5	
	2,5	14	CDMD 2.5	CDFD 2.5	

Wiring information, CD contacts

conductor section (mm ²)	conductor slot ø A (mm)	stripping length B (mm)
0,14-0,37	0,9	8
0,5	1,1	8
0,75	1,3	8
1,0	1,45	8
1,5	1,8	8
2,5	2,2	6

Wire diameter: up to 3,8 mm.

For basic or high thickness gold plating, please refer to page [E.16](#)

For stamped crimp contacts (SD series), please refer to page [E.18](#)

It is recommended to use the crimping tools and removal tools homologated by ILME (please see page [E.23](#))

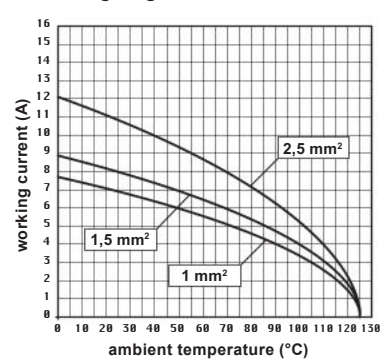
Materials

Insert	polycarbonate (PC)
UL 94 flame rating	V-0
Colour	pebble grey, RAL 7032
Contacts	copper alloy, silver ● and gold ● plated

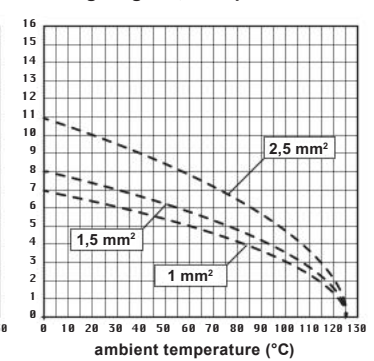
CR CP
Coding pins
Page [E.3](#)

Enclosures size 77.27	Pages
Heavy-Duty Applications	
Metallic with C-TYPE lever	E.62-69
Metallic with IL-BRID lever	E.96-99 , 106
Metallic with JEI®-P lever	E.115-116 , 119
Metallic with V-TYPE IP67 lever	E.126 , 132-133
Thermoplastic T-TYPE	E.230-231 , 234-235
Aggressive Environments	
Metallic IP68 high protection	E.146-147
Metallic W-TYPE	E.158-159 , 164
Metallic E-Xtreme®	E.178-179 , 186-187 , 196
Thermoplastic T-TYPE/W	E.230-231 , 234-235
Specialized Applications	
EMC (Electromagnetic Shielding)	E.212-213 , 216
Hygienic series for food and beverage	E.246 , 248
Standard applications with Central lever	E.258-259
BIG Enclosures for multiple cable entries	E.270 , 276-277
COB system for switch cabinet	E.286-289
Light and Sound applications with JEI®-P lever	E.300-301

CD 40 inserts max. current load derating diagram, turned contacts



CD 40 inserts max. current load derating diagram, stamped contacts



For applications requiring higher voltages, please see the special voltage application section on page [E.83](#)

CD 64

10 A 250 V

size **104.27**
64 poles + ⊕

Crimp connection

EN 61984 rating	10 A 250 V 4 kV 3
	10 A 230 / 400 V 4 kV 2
Rated voltage (UL / CSA)	600 V
Insulation resistance	≥ 10 GΩ
Contact resistance	≤ 3 mΩ
Ambient temperature limit	-40 °C ... +125 °C
Mechanical life (cycles)	≥ 500



UL US ECBT2.E115072 | ECBT8.E115072

Item	Description	Part No.	Dimension
	Male inserts for male contacts Without contacts (to be ordered separately)	CDM 64	
	Female inserts for female contacts Without contacts (to be ordered separately)	CDF 64	

10 A crimp contacts	section (mm ²)		section (AWG)		Male	Female				
	0,14-0,37	0,5	26-22	20						
	0,5	0,75	18	18	silver	CDMA 0.3 CDFA 0.3 CDMA 0.5 CDFA 0.5 CDMA 0.7 CDFA 0.7 CDMA 1.0 CDFA 1.0 CDMA 1.5 CDFA 1.5 CDMA 2.5 CDFA 2.5				
	1	1,5	18	16						
	2,5	14	14	14						
	0,14-0,37	0,5	26-22	20				gold	CDMD 0.3 CDFD 0.3 CDMD 0.5 CDFD 0.5 CDMD 0.7 CDFD 0.7 CDMD 1.0 CDFD 1.0 CDMD 1.5 CDFD 1.5 CDMD 2.5 CDFD 2.5	
	0,5	0,75	18	18						
	1	1,5	18	16						
	2,5	14	14	14						

Wiring information, CD contacts

conductor section (mm ²)	conductor slot ø A (mm)	stripping length B (mm)
0,14-0,37	0,9	8
0,5	1,1	8
0,75	1,3	8
1,0	1,45	8
1,5	1,8	8
2,5	2,2	6

Wire diameter: up to 3,8 mm.

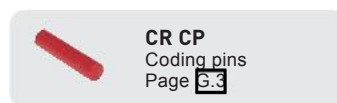
For basic or high thickness gold plating, please refer to page [E.16](#)

For stamped crimp contacts (SD series), please refer to page [E.18](#)

It is recommended to use the crimping tools and removal tools homologated by ILME (please see page [E.23](#))

Materials

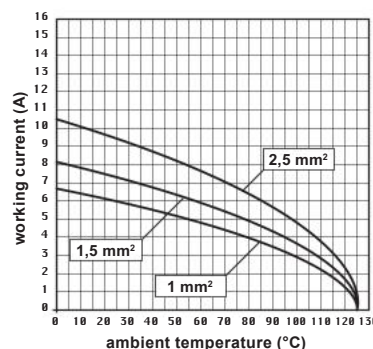
Insert	polycarbonate (PC)
UL 94 flame rating	V-0
Colour	pebble grey, RAL 7032
Contacts	copper alloy, silver ● and gold ● plated



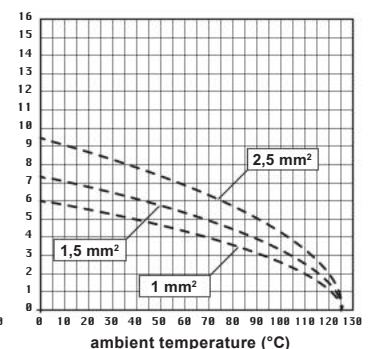
Enclosures size 104.27	Pages
Heavy-Duty Applications	
Metallic with C-TYPE lever	E.70-77
Metallic with IL-BRID lever	E.100-103 107
Metallic with JEI®-P lever	E.117-119
Metallic with V-TYPE IP67 lever	E.127 134-135
Thermoplastic T-TYPE	E.232-235
Aggressive Environments	
Metallic IP68 high protection	E.148-149
Metallic W-TYPE	E.160-161 165
Metallic E-Xtreme®	E.180-181 188-189 197
Thermoplastic T-TYPE/W	E.232-235
Specialized Applications	
EMC (Electromagnetic Shielding)	E.214-215 219
Hygienic series for food and beverage	E.247-248
Standard applications with Central lever	E.260-261
BIG Enclosures for multiple cable entries	E.271 278-279
COB system for switch cabinet	E.286-289
Light and Sound applications with JEI®-P lever	E.302-303

For applications requiring higher voltages, please see the special voltage application section on page [E.89](#)

CD 64 inserts max. current load derating diagram, turned contacts



CD 64 inserts max. current load derating diagram, stamped contacts



CD 40 + CD 40

10 A 250 V

size **77.62**

80 poles +

Crimp connection

EN 61984 rating	10 A 250 V 4 kV 3
	10 A 230 / 400 V 4 kV 2
Rated voltage (UL / CSA)	600 V
Insulation resistance	≥ 10 GΩ
Contact resistance	≤ 3 mΩ
Ambient temperature limit	-40 °C ... +125 °C
Mechanical life (cycles)	≥ 500

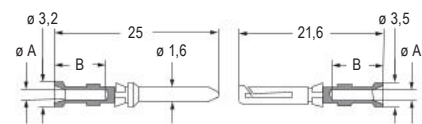


CAIUS ECBT2.E115072 | ECBT8.E115072

Item	Description	Part No.	Dimension
	Male inserts for male contacts Without contacts (to be ordered separately)	CDM 40 CDM 40	
	Female inserts for female contacts Without contacts (to be ordered separately)	CDF 40 CDF 40	

10 A crimp contacts		Male	Female
section (mm ²)	section (AWG)		
0,14-0,37	26-22		
0,5	20		
0,75	18		
1	18		
1,5	16		
2,5	14		
0,14-0,37	26-22		
0,5	20		
0,75	18		
1	18		
1,5	16		
2,5	14		

silver	CDMA 0.3	CDFA 0.3
	CDMA 0.5	CDFA 0.5
	CDMA 0.7	CDFA 0.7
	CDMA 1.0	CDFA 1.0
	CDMA 1.5	CDFA 1.5
	CDMA 2.5	CDFA 2.5
gold	CDMD 0.3	CDFD 0.3
	CDMD 0.5	CDFD 0.5
	CDMD 0.7	CDFD 0.7
	CDMD 1.0	CDFD 1.0
	CDMD 1.5	CDFD 1.5
	CDMD 2.5	CDFD 2.5



Wiring information, CD contacts

conductor section (mm ²)	conductor slot ø A (mm)	stripping length B (mm)
0,14-0,37	0,9	8
0,5	1,1	8
0,75	1,3	8
1,0	1,45	8
1,5	1,8	8
2,5	2,2	6

Wire diameter: up to 3,8 mm.
 For basic or high thickness gold plating, please refer to page [E.16](#).
 For stamped crimp contacts (SD series), please refer to page [E.18](#).
 It is recommended to use the crimping tools and removal tools homologated by ILME (please see page [E.23](#)).

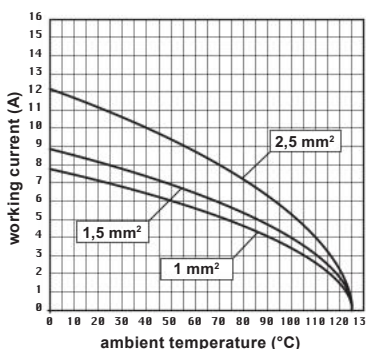
Materials

Insert	polycarbonate (PC)
UL 94 flame rating	V-0
Colour	pebble grey, RAL 7032
Contacts	copper alloy, silver ● and gold ● plated

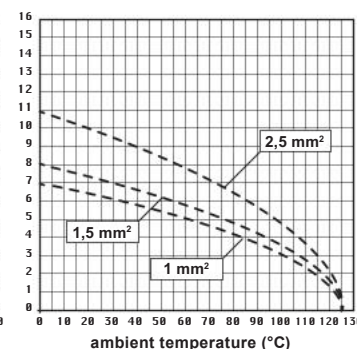
CR CP
Coding pins
Page [E.3](#)

Enclosures size 77.62	Pages
Heavy-Duty Applications	
Metallic with C-TYPE lever	E.78-83
Aggressive Environments	
Metallic W-TYPE with C-TYPE lever	E.166-167
Metallic E-Xtreme® with C-TYPE lever	E.190-191

CD 40 inserts max. current load derating diagram, turned contacts



CD 40 inserts max. current load derating diagram, stamped contacts



For applications requiring higher voltages, please see the special voltage application section on page [E.83](#)

CD 64 + CD 64

10 A 250 V

size **104.62**

128 poles +

Crimp connection

EN 61984 rating	10 A 250 V 4 kV 3
	10 A 230 / 400 V 4 kV 2
Rated voltage (UL / CSA)	600 V
Insulation resistance	≥ 10 GΩ
Contact resistance	≤ 3 mΩ
Ambient temperature limit	-40 °C ... +125 °C
Mechanical life (cycles)	≥ 500

CE UK EAC



ILME ECBT2.E115072 | ECBT8.E115072

Item	Description	Part No.	Dimension																					
	Male inserts for male contacts Without contacts (to be ordered separately)	CDM 64 CDF 64																						
	Female inserts for female contacts Without contacts (to be ordered separately)	CDF 64 CDM 64																						
	10 A crimp contacts section (mm ²) section (AWG)	Male Female																						
	0,14-0,37 26-22	CDMA 0.3 CDFA 0.3																						
	0,5 20	CDMA 0.5 CDFA 0.5																						
	0,75 18	CDMA 0.7 CDFA 0.7																						
	1 18	CDMA 1.0 CDFA 1.0																						
	1,5 16	CDMA 1.5 CDFA 1.5																						
	2,5 14	CDMA 2.5 CDFA 2.5																						
	0,14-0,37 26-22	CDMD 0.3 CDFD 0.3																						
	0,5 20	CDMD 0.5 CDFD 0.5																						
	0,75 18	CDMD 0.7 CDFD 0.7																						
	1 18	CDMD 1.0 CDFD 1.0																						
	1,5 16	CDMD 1.5 CDFD 1.5																						
	2,5 14	CDMD 2.5 CDFD 2.5																						
			Wiring information, CD contacts																					
			<table border="1"> <thead> <tr> <th>conductor section (mm²)</th> <th>conductor slot ø A (mm)</th> <th>stripping length B (mm)</th> </tr> </thead> <tbody> <tr> <td>0,14-0,37</td> <td>0,9</td> <td>8</td> </tr> <tr> <td>0,5</td> <td>1,1</td> <td>8</td> </tr> <tr> <td>0,75</td> <td>1,3</td> <td>8</td> </tr> <tr> <td>1,0</td> <td>1,45</td> <td>8</td> </tr> <tr> <td>1,5</td> <td>1,8</td> <td>8</td> </tr> <tr> <td>2,5</td> <td>2,2</td> <td>6</td> </tr> </tbody> </table>	conductor section (mm ²)	conductor slot ø A (mm)	stripping length B (mm)	0,14-0,37	0,9	8	0,5	1,1	8	0,75	1,3	8	1,0	1,45	8	1,5	1,8	8	2,5	2,2	6
conductor section (mm ²)	conductor slot ø A (mm)	stripping length B (mm)																						
0,14-0,37	0,9	8																						
0,5	1,1	8																						
0,75	1,3	8																						
1,0	1,45	8																						
1,5	1,8	8																						
2,5	2,2	6																						
			Wire diameter: up to 3,8 mm.																					
			For basic or high thickness gold plating, please refer to page E.16																					
			For stamped crimp contacts (SD series), please refer to page E.18																					
			It is recommended to use the crimping tools and removal tools homologated by ILME (please see page E.23)																					

Materials

Insert	polycarbonate (PC)
UL 94 flame rating	V-0
Colour	pebble grey, RAL 7032
Contacts	copper alloy, silver and gold plated



CR CP
Coding pins
Page [E.3](#)

Enclosures size 104.62

Pages [E.84-E.85](#)

Heavy-Duty Applications

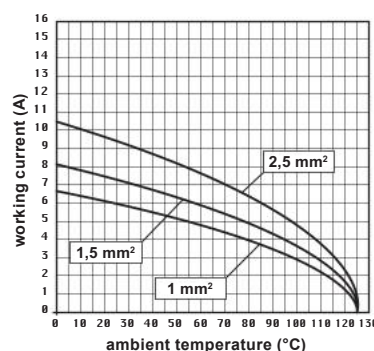
Metallic with C-TYPE lever [E.84-85](#)

Aggressive Environments

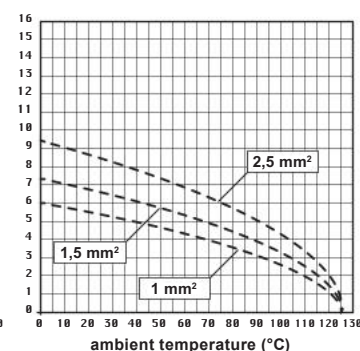
Metallic W-TYPE with C-TYPE lever [E.168-169](#)

Metallic E-Xtreme® with C-TYPE lever [E.192-193](#)

CD 64 inserts max. current load derating diagram, turned contacts



CD 64 inserts max. current load derating diagram, stamped contacts



For applications requiring higher voltages, please see the special voltage application section on page [E.89](#)

CDD 24

10 A 250 V


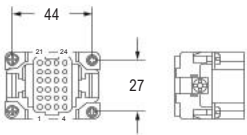
size **44.27**
24 poles + ⊕

Crimp connection

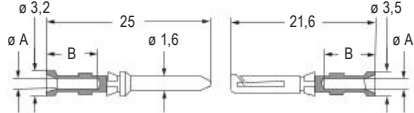
EN 61984 rating	10 A 250 V 4 kV 2
Rated voltage (UL / CSA)	600 V
Insulation resistance	≥ 10 GΩ
Contact resistance	≤ 3 mΩ
Ambient temperature limit	-40 °C ... +125 °C
Mechanical life (cycles)	≥ 500



ILME US ECBT2.E115072 | ECBT8.E115072

Item	Description	Part No.	Dimension
	Male inserts for male contacts Without contacts (to be ordered separately)	CDDM 24	

	Female inserts for female contacts Without contacts (to be ordered separately)	CDDF 24	
---	--	-------------------------	---

10 A crimp contacts	section (mm ²)		section (AWG)		Male	Female	
	0,14-0,37	0,5	0,75	1	1,5	2,5	
	0,14-0,37	0,5	26-22	20			
	0,75	1	18	18			
	1,5	1,5	16	16			
	2,5	2,5	14	14			
	0,14-0,37	0,5	26-22	20			
	0,75	1	18	18			
	1,5	1,5	16	16			
	2,5	2,5	14	14			

	Male	Female
silver	CDMA 0.3	CDFA 0.3
	CDMA 0.5	CDFA 0.5
	CDMA 0.7	CDFA 0.7
	CDMA 1.0	CDFA 1.0
	CDMA 1.5	CDFA 1.5
gold	CDMD 0.3	CDFD 0.3
	CDMD 0.5	CDFD 0.5
	CDMD 0.7	CDFD 0.7
	CDMD 1.0	CDFD 1.0
	CDMD 1.5	CDFD 1.5

Wiring information, CD contacts

conductor section (mm ²)	conductor slot ø A (mm)	stripping length B (mm)
0,14-0,37	0,9	8
0,5	1,1	8
0,75	1,3	8
1,0	1,45	8
1,5	1,8	8
2,5	2,2	6

Wire diameter: up to 3,8 mm.
For basic or high thickness gold plating, please refer to page [E.16](#).
For stamped crimp contacts (SD series), please refer to page [E.18](#).
It is recommended to use the crimping tools and removal tools homologated by ILME (please see page [E.23](#)).

Materials

Insert	polycarbonate (PC)
UL 94 flame rating	V-0
Colour	pebble grey, RAL 7032
Contacts	copper alloy, silver ● and gold ● plated



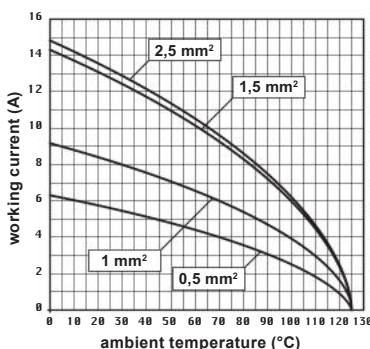
CIF 2.4
PCB adapter
Page [D.14](#)



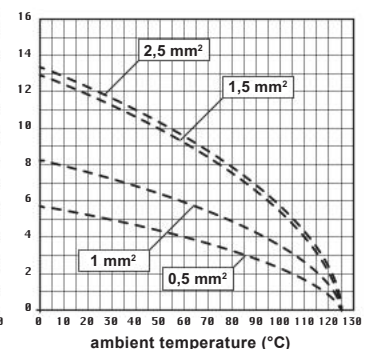
CR CP
Coding pins
Page [G.3](#)

Enclosures size 44.27	Pages
Heavy-Duty Applications	
Metallic with C-TYPE lever	E.48-53
Metallic with IL-BRID lever	E.90-91 , 104
Metallic with JEI®-P lever	E.112 , 119
Metallic with V-TYPE IP67 lever	E.124 , 128-129
Thermoplastic T-TYPE	E.226-227 , 234-235
Aggressive Environments	
Metallic IP68 high protection	E.142-143
Metallic W-TYPE	E.154-155 , 162
Metallic E-Xtreme®	E.174-175 , 182-183 , 194
Thermoplastic T-TYPE/W	E.226-227 , 234-235
Specialized Applications	
EMC (Electromagnetic Shielding)	E.208-209 , 216
Hygienic series for food and beverage	E.244 , 248
Standard applications with Central lever	E.254-255
BIG Enclosures for multiple cable entries	E.268 , 272-273
COB system for switch cabinet	E.286-289
Light and Sound applications with JEI®-P lever	E.296-297

CDD 24 inserts max. current load derating diagram, turned contacts



CDD 24 inserts max. current load derating diagram, stamped contacts



For applications requiring higher voltages, please see the special voltage application section on page [E.89](#)

CDD 42

10 A 250 V

size 57.27

42 poles +

Crimp connection

EN 61984 rating	10 A 250 V 4 kV 2
Rated voltage (UL / CSA)	600 V
Insulation resistance	≥ 10 GΩ
Contact resistance	≤ 3 mΩ
Ambient temperature limit	-40 °C ... +125 °C
Mechanical life (cycles)	≥ 500

ECBT2.E115072 | ECBT8.E115072

Item	Description	Part No.	Dimension
	Male inserts for male contacts Without contacts (to be ordered separately)	CDDM 42	

	Female inserts for female contacts Without contacts (to be ordered separately)	CDDF 42	
--	--	-------------------------	--

10 A crimp contacts	section (mm ²)		section (AWG)		Male	Female	
	0,14-0,37	0,5	0,75	1	1,5	2,5	
	0,14-0,37	0,5	26-22	20	18	18	
	0,75	1	18	18	18	18	
	1,5	1,5	16	16	16	16	
	2,5	2,5	14	14	14	14	
	0,14-0,37	0,5	26-22	20	18	18	
	0,75	1	18	18	18	18	
	1,5	1,5	16	16	16	16	
	2,5	2,5	14	14	14	14	
	0,14-0,37	0,5	26-22	20	18	18	
	0,75	1	18	18	18	18	

Wiring information, CD contacts

conductor section (mm ²)	conductor slot ø A (mm)	stripping length B (mm)
0,14-0,37	0,9	8
0,5	1,1	8
0,75	1,3	8
1,0	1,45	8
1,5	1,8	8
2,5	2,2	6

Wire diameter: up to 3,8 mm.

 For basic or high thickness gold plating, please refer to page [E.16](#)

 For stamped crimp contacts (SD series), please refer to page [E.18](#)

 It is recommended to use the crimping tools and removal tools homologated by ILME (please see page [E.23](#))

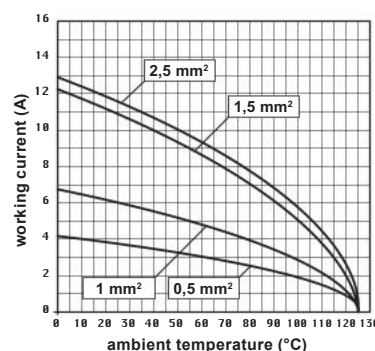
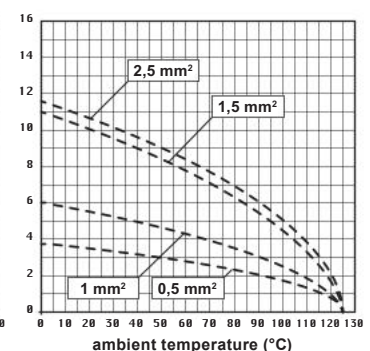
Materials

Insert	polycarbonate (PC)
UL 94 flame rating	V-0
Colour	pebble grey, RAL 7032
Contacts	copper alloy, silver and gold plated


CIF 2.4
PCB adapter
Page [D.14](#)

CR CP
Coding pins
Page [E.3](#)

Enclosures size 57.27	Pages
Heavy-Duty Applications	
Metallic with C-TYPE lever	E.54-61
Metallic with IL-BRID lever	E.92-95 E.106
Metallic with JEI®-P lever	E.113-114 E.119
Metallic with V-TYPE IP67 lever	E.125 E.130-131
Thermoplastic T-TYPE	E.228-229 E.234-235
Aggressive Environments	
Metallic IP68 high protection	E.144-145
Metallic W-TYPE	E.156-157 E.163
Metallic E-Xtreme®	E.176-177 E.184-185 E.195
Thermoplastic T-TYPE/W	E.228-229 E.234-235
Specialized Applications	
EMC (Electromagnetic Shielding)	E.210-211 E.217
Hygienic series for food and beverage	E.243 E.248
Standard applications with Central lever	E.256-257
BIG Enclosures for multiple cable entries	E.269 E.274-275
COB system for switch cabinet	E.286-289
Light and Sound applications with JEI®-P lever	E.298-299

 For applications requiring higher voltages, please see the special voltage application section on page [E.89](#)
CDD 42 inserts max. current load derating diagram, turned contacts

CDD 42 inserts max. current load derating diagram, stamped contacts


CDD 72

10 A 250 V

size **77.27**


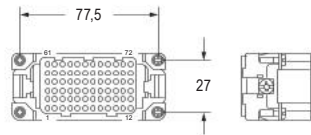
72 poles + ⊕

Crimp connection

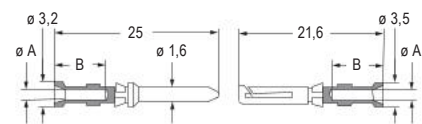
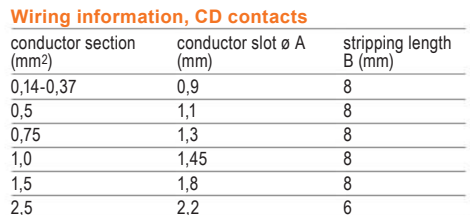
EN 61984 rating	10 A 250 V 4 kV 2
Rated voltage (UL / CSA)	600 V
Insulation resistance	≥ 10 GΩ
Contact resistance	≤ 3 mΩ
Ambient temperature limit	-40 °C ... +125 °C
Mechanical life (cycles)	≥ 500



ILME US ECBT2.E115072 | ECBT8.E115072

Item	Description	Part No.	Dimension
	Male inserts for male contacts Without contacts (to be ordered separately)	CDDM 72	

	Female inserts for female contacts Without contacts (to be ordered separately)	CDDF 72	
---	--	-------------------------	---

10 A crimp contacts	section (mm ²)		section (AWG)		Male	Female	
	0,14-0,37	0,5	26-22	20	silver	gold	
	0,5	0,75	18	18	CDMA 0.3	CDFA 0.3	
	1	1,5	18	16	CDMA 0.5	CDFA 0.5	
	1,5	2,5	16	14	CDMA 0.7	CDFA 0.7	
	2,5		14		CDMA 1.0	CDFA 1.0	
					CDMA 1.5	CDFA 1.5	
					CDMA 2.5	CDFA 2.5	
	0,14-0,37	0,5	26-22	20	CDMD 0.3	CDDF 0.3	
	0,5	0,75	18	18	CDMD 0.5	CDDF 0.5	
	0,75	1	18	18	CDMD 0.7	CDDF 0.7	
	1	1,5	18	16	CDMD 1.0	CDDF 1.0	
	1,5	2,5	16	14	CDMD 1.5	CDDF 1.5	
	2,5		14		CDMD 2.5	CDDF 2.5	

Wiring information, CD contacts

conductor section (mm ²)	conductor slot ø A (mm)	stripping length B (mm)
0,14-0,37	0,9	8
0,5	1,1	8
0,75	1,3	8
1,0	1,45	8
1,5	1,8	8
2,5	2,2	6

Wire diameter: up to 3,8 mm.

For basic or high thickness gold plating, please refer to page [E.16](#)

For stamped crimp contacts (SD series), please refer to page [E.18](#)

It is recommended to use the crimping tools and removal tools homologated by ILME (please see page [E.23](#))

Materials

Insert	polycarbonate (PC)
UL 94 flame rating	V-0
Colour	pebble grey, RAL 7032
Contacts	copper alloy, silver ● and gold ● plated



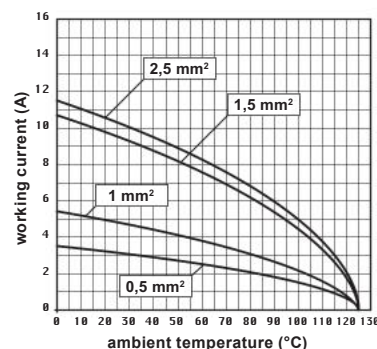
CIF 2.4
PCB adapter
Page [D.14](#)



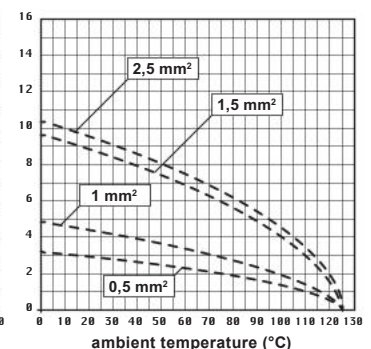
CR CP
Coding pins
Page [G.3](#)

Enclosures size 77.27	Pages
Heavy-Duty Applications	
Metallic with C-TYPE lever	E.62-69
Metallic with IL-BRID lever	E.96-99 , 106
Metallic with JEI®-P lever	E.115-116 , 119
Metallic with V-TYPE IP67 lever	E.126 , 132-133
Thermoplastic T-TYPE	E.230-231 , 234-235
Aggressive Environments	
Metallic IP68 high protection	E.146-147
Metallic W-TYPE	E.158-159 , 164
Metallic E-Xtreme®	E.178-179 , 186-187 , 196
Thermoplastic T-TYPE/W	E.230-231 , 234-235
Specialized Applications	
EMC (Electromagnetic Shielding)	E.212-213 , 216
Hygienic series for food and beverage	E.246 , 248
Standard applications with Central lever	E.258-259
BIG Enclosures for multiple cable entries	E.270 , 276-277
COB system for switch cabinet	E.286-289
Light and Sound applications with JEI®-P lever	E.300-301

CDD 72 inserts max. current load derating diagram, turned contacts



CDD 72 inserts max. current load derating diagram, stamped contacts



For applications requiring higher voltages, please see the special voltage application section on page [E.83](#)

CDD 108

10 A 250 V

size **104.27**

108 poles + ⊕

Crimp connection

EN 61984 rating	10 A 250 V 4 kV 2
Rated voltage (UL / CSA)	600 V
Insulation resistance	≥ 10 GΩ
Contact resistance	≤ 3 mΩ
Ambient temperature limit	-40 °C ... +125 °C
Mechanical life (cycles)	≥ 500

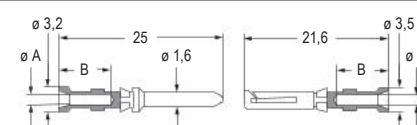


ILME US ECBT2.E115072 | ECBT8.E115072

Item	Description	Part No.	Dimension
	Male inserts for male contacts Without contacts (to be ordered separately)	CDDM 108	

	Female inserts for female contacts Without contacts (to be ordered separately)	CDDF 108	
--	--	--------------------------	--

10 A crimp contacts		Male	Female	Wiring information, CD contacts	
section (mm ²)	section (AWG)			conductor section (mm ²)	conductor slot ø A (mm)
0,14-0,37	26-22		CDMA 0.3 CDFA 0.3	0,14-0,37	0,9
0,5	20		CDMA 0.5 CDFA 0.5	0,5	1,1
0,75	18		CDMA 0.7 CDFA 0.7	0,75	1,3
1	18		CDMA 1.0 CDFA 1.0	1,0	1,45
1,5	16		CDMA 1.5 CDFA 1.5	1,5	1,8
2,5	14		CDMA 2.5 CDFA 2.5	2,5	2,2
0,14-0,37	26-22		CDMD 0.3 CDFD 0.3		
0,5	20		CDMD 0.5 CDFD 0.5		
0,75	18		CDMD 0.7 CDFD 0.7		
1	18		CDMD 1.0 CDFD 1.0		
1,5	16		CDMD 1.5 CDFD 1.5		
2,5	14		CDMD 2.5 CDFD 2.5		



Wiring information, CD contacts

conductor section (mm ²)	conductor slot ø A (mm)	stripping length B (mm)
0,14-0,37	0,9	8
0,5	1,1	8
0,75	1,3	8
1,0	1,45	8
1,5	1,8	8
2,5	2,2	6

Wire diameter: up to 3,8 mm.

For basic or high thickness gold plating, please refer to page [E.16](#)

For stamped crimp contacts (SD series), please refer to page [E.18](#)

It is recommended to use the crimping tools and removal tools homologated by ILME (please see page [E.23](#))

Materials

Insert	polycarbonate (PC)
UL 94 flame rating	V-0
Colour	pebble grey, RAL 7032
Contacts	copper alloy, silver ● and gold ● plated



CIF 2.4
PCB adapter
Page [D.14](#)



CR CP
Coding pins
Page [E.3](#)

Enclosures size 104.27

Pages

Heavy-Duty Applications

Metallic with C-TYPE lever	E.70-77
Metallic with IL-BRID lever	E.100-103 E.107
Metallic with JEI®-P lever	E.117-119
Metallic with V-TYPE IP67 lever	E.127 E.134-135
Thermoplastic T-TYPE	E.232-235

Aggressive Environments

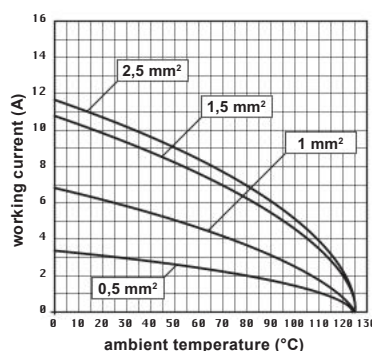
Metallic IP68 high protection	E.148-149
Metallic W-TYPE	E.160-161 E.165
Metallic E-Xtreme®	E.180-181 E.188-189 E.197
Thermoplastic T-TYPE/W	E.232-235

Specialized Applications

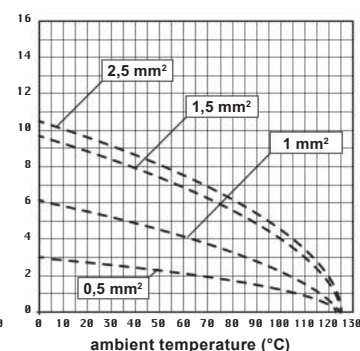
EMC (Electromagnetic Shielding)	E.214-215 E.219
Hygienic series for food and beverage	E.247-248
Standard applications with Central lever	E.260-261
BIG Enclosures for multiple cable entries	E.271 E.278-279
COB system for switch cabinet	E.286-289
Light and Sound applications with JEI®-P lever	E.302-303

For applications requiring higher voltages, please see the special voltage application section on page [E.89](#)

CDD 108 inserts max. current load derating diagram, turned contacts



CDD 108 inserts max. current load derating diagram, stamped contacts



CDD 72 + CDD 72 N

10 A 250 V


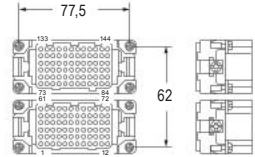

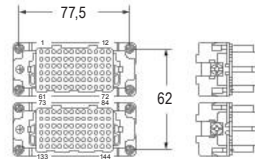
size **77.62**
144 poles + 

Crimp connection



EN 61984 rating	10 A 250 V 4 kV 2
Rated voltage (UL / CSA)	600 V
Insulation resistance	≥ 10 GΩ
Contact resistance	≤ 3 mΩ
Ambient temperature limit	-40 °C ... +125 °C
Mechanical life (cycles)	≥ 500

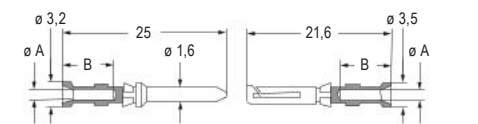


CAI[®] US ECBT2.E115072 | ECBT8.E115072

Item	Description	Part No.	Dimension
	Male inserts, No. (1-72) Male inserts, No. (73-144) Without contacts (to be ordered separately)	CDDM 72 CDDM 72 N	
	Female inserts, No. (1-72) Female inserts, No. (73-144) Without contacts (to be ordered separately)	CDDF 72 CDDF 72 N	

CDD
B

10 A crimp contacts		Male	Female
section (mm ²)	section (AWG)		
0,14-0,37	26-22	 CDMA 0.3	CDFA 0.3
0,5	20	CDMA 0.5	CDFA 0.5
0,75	18	CDMA 0.7	CDFA 0.7
1	18	CDMA 1.0	CDFA 1.0
1,5	16	CDMA 1.5	CDFA 1.5
2,5	14	CDMA 2.5	CDFA 2.5
		 CDMD 0.3	CDFD 0.3
0,14-0,37	26-22	CDMD 0.5	CDFD 0.5
0,5	20	CDMD 0.7	CDFD 0.7
0,75	18	CDMD 1.0	CDFD 1.0
1	18	CDMD 1.5	CDFD 1.5
1,5	16	CDMD 2.5	CDFD 2.5



Wiring information, CD contacts

conductor section (mm ²)	conductor slot ø A (mm)	stripping length B (mm)
0,14-0,37	0,9	8
0,5	1,1	8
0,75	1,3	8
1,0	1,45	8
1,5	1,8	8
2,5	2,2	6

Wire diameter: up to 3,8 mm.

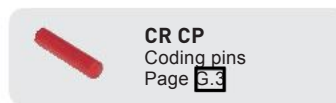
For basic or high thickness gold plating, please refer to page [E.16](#)

For stamped crimp contacts (SD series), please refer to page [E.18](#)

It is recommended to use the crimping tools and removal tools homologated by ILME (please see page [E.23](#))

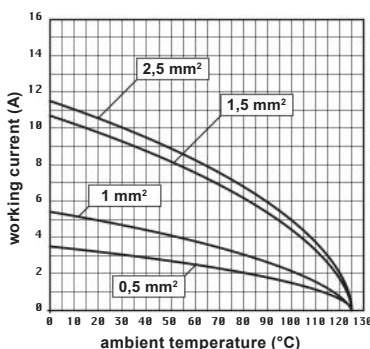
Materials

Insert	polycarbonate (PC)
UL 94 flame rating	V-0
Colour	pebble grey, RAL 7032
Contacts	copper alloy, silver ● and gold ● plated

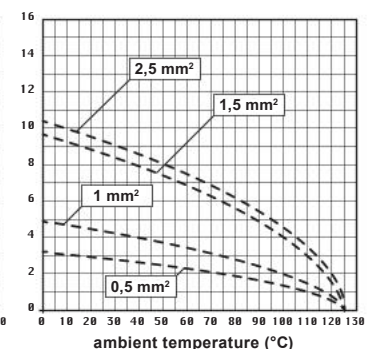


Enclosures size 77.62	Pages
Heavy-Duty Applications	
Metallic with C-TYPE lever	E.78-83
Aggressive Environments	
Metallic W-TYPE with C-TYPE lever	E.166-167
Metallic E-Xtreme® with C-TYPE lever	E.190-191

CDD 72 inserts max. current load derating diagram, turned contacts



CDD 72 inserts max. current load derating diagram, stamped contacts



For applications requiring higher voltages, please see the special voltage application section on page [E.89](#)

CDD 108 + CDD 108 N

10 A 250 V

size **104.62**

216 poles +

Crimp connection

EN 61984 rating	10 A 250 V 4 kV 2
Rated voltage (UL / CSA)	600 V
Insulation resistance	≥ 10 GΩ
Contact resistance	≤ 3 mΩ
Ambient temperature limit	-40 °C ... +125 °C
Mechanical life (cycles)	≥ 500



ILME ECBT2.E115072 | ECBT8.E115072

Item	Description	Part No.	Dimension
	Male inserts, No. (1-108) Male inserts, No. (109-216) Without contacts (to be ordered separately)	CDDM 108 CDDM 108 N	

	Female inserts, No. (1-108) Female inserts, No. (109-216) Without contacts (to be ordered separately)	CDDF 108 CDDF 108 N	
--	--	--	--

10 A crimp contacts	section (mm ²) section (AWG)		Male	Female	
	0,14-0,37	26-22			
	0,5	20	silver	CDMA 0.3	CDFA 0.3
	0,75	18		CDMA 0.5	CDFA 0.5
	1	18		CDMA 0.7	CDFA 0.7
	1,5	16		CDMA 1.0	CDFA 1.0
	2,5	14		CDMA 1.5	CDFA 1.5
	0,14-0,37	26-22	gold	CDMD 0.3	CDFD 0.3
	0,5	20		CDMD 0.5	CDFD 0.5
	0,75	18		CDMD 0.7	CDFD 0.7
	1	18		CDMD 1.0	CDFD 1.0
	1,5	16		CDMD 1.5	CDFD 1.5
2,5	14	CDMD 2.5	CDFD 2.5		

Wiring information, CD contacts

conductor section (mm ²)	conductor slot ø A (mm)	stripping length B (mm)
0,14-0,37	0,9	8
0,5	1,1	8
0,75	1,3	8
1,0	1,45	8
1,5	1,8	8
2,5	2,2	6

Wire diameter: up to 3,8 mm.

For basic or high thickness gold plating, please refer to page [E.16](#)

For stamped crimp contacts (SD series), please refer to page [E.18](#)

It is recommended to use the crimping tools and removal tools homologated by ILME (please see page [E.23](#))

Materials

Insert	polycarbonate (PC)
UL 94 flame rating	V-0
Colour	pebble grey, RAL 7032
Contacts	copper alloy, silver ● and gold ● plated

CR CP
Coding pins
Page [E.3](#)

Enclosures size 104.62

Pages [E.84-E.89](#)

Heavy-Duty Applications

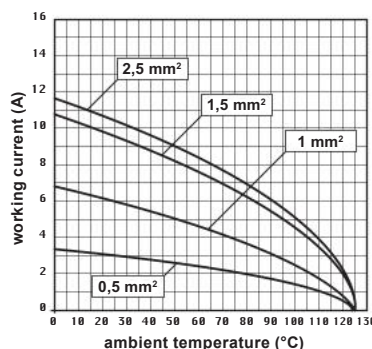
Metallic with C-TYPE lever [E.84-89](#)

Aggressive Environments

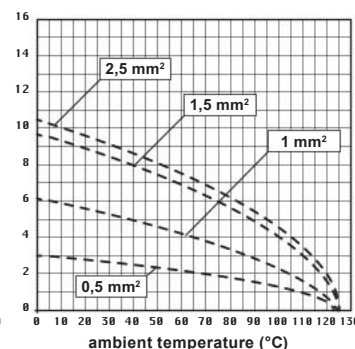
Metallic W-TYPE with C-TYPE lever [E.168-169](#)

Metallic E-Xtreme® with C-TYPE lever [E.192-193](#)

CDD 108 inserts max. current load derating diagram, turned contacts



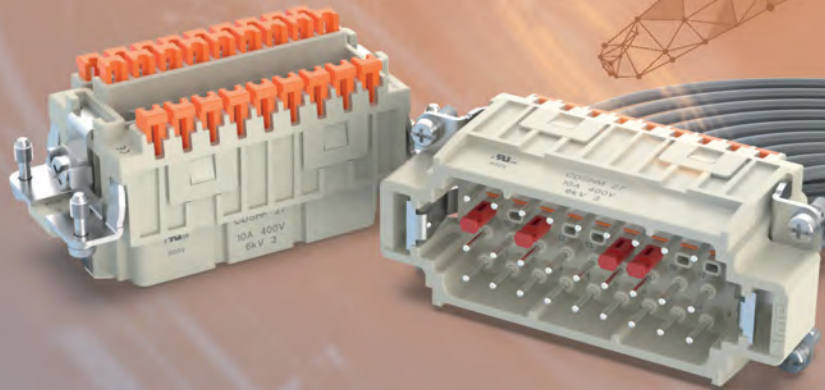
CDD 108 inserts max. current load derating diagram, stamped contacts



For applications requiring higher voltages, please see the special voltage application section on page [E.89](#)

CDSH-SQUICH® series

Connection without tools. The highest density.



CDSH series overview

The continuous demand for a greater number of poles and smaller dimensions has led to the design and manufacture of the new CDSH series, which offers single connectors with a **max. number of 84 poles** that occupy the **same space of standard connectors** with screw/spring connection.

Each of the spring terminals has an actuator button, suitably shaped and incorporated in the cavity. When this button is pushed, it triggers the closure of the spring device of the corresponding terminal, safely and reliably connecting the conductor to its respective electric contact in the connector.

The actuator buttons are supplied raised, in the “open terminal” position and are **easily distinguishable by the orange colour** which makes them stand out from the insulating body of the connector.

The advantage of this exclusive solution is that **the actuators disappear completely within the body of the connector**, making it easy to identify terminals not yet closed and **eliminating possible obstacles** to the movement of the conductors during installation and maintenance.

SQUICH® technology requires no tools to activate the terminal and a **simple operation is all you need to make the connection**.



Watch our clip

CDSH INSERTS SUM UP

- > Greater pole density as compared to existing connector with screw terminals: **SAVE SPACE +70%**
- > Reduced wiring time: **SAVE TIME -50%**

STANDARD 16 A	CDSH - HIGH DENSITY 10 A
06 poles	09 poles +50%
10 poles	18 poles +80%
16 poles	27 poles +70%
24 poles	42 poles +75%
32 poles	54 poles +70%
48 poles	84 poles +75%

- > **Wiring tool is not necessary**
- > **Quick identification of wired and non-wired terminals**
- > **Terminals already open and ready for conductor clamping**
- > **Option to use wires up to 2,5 mm²**
- > **Built-in silver plated contacts**
- > **Excellent fastening solution**
- > **Great resistance to strong vibrations**
- > **CDSH series can be used with the whole range of ILME enclosures**

It is possible to insert in the mating area the **CR CDS plastic coding pin** that enables the polarisation of inserts in a wide range of combinations. This means that it is possible to install side by side identical connectors with different functions.



The CR CDS coding pins **can also be used in combination with CR 20 / CRM / CRF / CR 72 metal pins** instead of insert fixing screws in order to increase the number of possible combinations. Each position of the coding pin used on the female insert must correspond to an unused position on the male insert.

The required number of coding pins, depending on the size of connectors, and the max. number of possible codings is shown in the table below.

Size of connectors	Slots for coding pins (M) = male insert (F) = female insert	Required coding pins for each coupling	Possible codings
9P + ⊕	3 (M) + 3 (F)	3 2 (M) + 1 (F)	3
18P + ⊕	6 (M) + 6 (F)	6 3 (M) + 3 (F)	20
27P + ⊕	9 (M) + 9 (F)	9 5 (M) + 4 (F)	126
42P + ⊕	14 (M) + 14 (F)	14 7 (M) + 7 (F)	3 432

FOCUS

- > No special wire preparation (other than stripping);
- > it offers an excellent fastening solution and a great resistance to strong vibrations;
- > it allows the use of solid and flexible wires, unprepared, with cross-sections between 0,14 mm² and 2,5 mm² (AWG 26-14);
- > for prepared wires, usable section: to 1,5 mm² (AWG 16);
- > a screwdriver with a 0,5 x 3,5 mm blade is the only tool required to remove the wire from the contact;
- > the profile of the actuator button allows the insertion of a test probe.

Inserts' technology

TECHNOLOGY AT A GLANCE

SQUICH®


1 Insert the wire into the contact hole

2 Just push the actuator button

CLICK!



The spring clamp safely fixes the wire

CDSH 09

10 A 400 V

size **44.27**

9 poles + ⊕

Tool-less connection – SQUICH®

EN 61984 rating	10 A 400 V 6 kV 3
	10 A 400 / 690 V 6 kV 2
Rated voltage (UL / CSA)	600 V
Insulation resistance	≥ 10 GΩ
Contact resistance	≤ 3 mΩ
Ambient temperature limit	-40 °C ... +125 °C
Mechanical life (cycles)	≥ 500



CAIUS ECBT2.E115072 | ECBT8.E115072

Item	Description	Part No.	Dimension
	Male inserts with male contacts Spring clamp connections, with actuator button	CDSHM 09	
	Female inserts with female contacts Spring clamp connections, with actuator button	CDSHF 09	

Materials

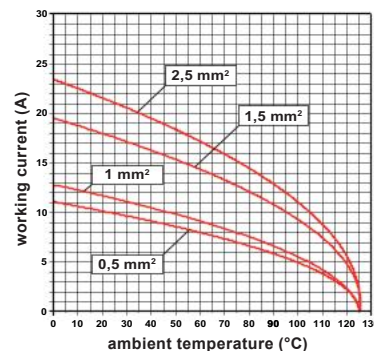
Insert	polycarbonate (PC)
UL 94 flame rating	V-0
Colour	pebble grey, RAL 7032
Contacts	built-in, copper alloy, silver ● plated

Wiring information

Wires cross sectional area	0,14 mm ² - 2,5 mm ² (AWG 26-14)
- unprepared	up to 1,5 mm ² (AWG 16)
- prepared	9...11 mm
Stripping length	

CR CDS
Coding pins
Page [6.10](#)

Enclosures size 44.27	Pages
Heavy-Duty Applications	
Metallic with C-TYPE lever	E.48-53
Metallic with IL-BRID lever	E.90-91, 104
Metallic with JEI®-P lever	E.112, 119
Metallic with V-TYPE IP67 lever	E.124, 128-129
Thermoplastic T-TYPE	E.226-227, 234-235
Aggressive Environments	
Metallic IP68 high protection	E.142-143
Metallic W-TYPE	E.154-155, 162
Metallic E-Xtreme®	E.174-175, 182-183, 194
Thermoplastic T-TYPE/W	E.226-227, 234-235
Specialized Applications	
EMC (Electromagnetic Shielding)	E.208-209, 216
Hygienic series for food and beverage	E.244, 248
Standard applications with Central lever	E.254-255
BIG Enclosures for multiple cable entries	E.268, 272-273
COB system for switch cabinet	E.286-289
Light and Sound applications with JEI®-P lever	E.296-297



CDSH 09 inserts max. current load derating diagram

CDSH 18

10 A 400 V

size **57.27**

18 poles + ⊕



Tool-less connection – SQUICH®

EN 61984 rating	10 A 400 V 6 kV 3
	10 A 400 / 690 V 6 kV 2
Rated voltage (UL / CSA)	600 V
Insulation resistance	≥ 10 GΩ
Contact resistance	≤ 3 mΩ
Ambient temperature limit	-40 °C ... +125 °C
Mechanical life (cycles)	≥ 500

CE UK EAC



C A U S ECBT2.E115072 | ECBT8.E115072

Item	Description	Part No.	Dimension
	Male inserts with male contacts Spring clamp connections, with actuator button	CDSHM 18	
	Female inserts with female contacts Spring clamp connections, with actuator button	CDSHF 18	

Materials

Insert	polycarbonate (PC)
UL 94 flame rating	V-0
Colour	pebble grey, RAL 7032
Contacts	built-in, copper alloy, silver ● plated

Wiring information

Wires cross sectional area	0,14 mm ² - 2,5 mm ² (AWG 26-14)
- unprepared	up to 1,5 mm ² (AWG 16)
- prepared	9...11 mm
Stripping length	



CR CDS
Coding pins
Page [6.10](#)

Enclosures size 57.27**Pages****Heavy-Duty Applications**

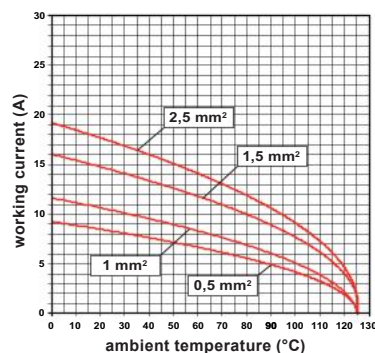
Metallic with C-TYPE lever	E.54-61
Metallic with IL-BRID lever	E.92-95, 105
Metallic with JEI®-P lever	E.113-114, 119
Metallic with V-TYPE IP67 lever	E.125, 130-131
Thermoplastic T-TYPE	E.228-229, 234-235

Aggressive Environments

Metallic IP68 high protection	E.144-145
Metallic W-TYPE	E.156-157, 163
Metallic E-Xtreme®	E.176-177, 184-185, 195
Thermoplastic T-TYPE/W	E.228-229, 234-235

Specialized Applications

EMC (Electromagnetic Shielding)	E.210-211, 217
Hygienic series for food and beverage	E.245, 248
Standard applications with Central lever	E.256-257
BIG Enclosures for multiple cable entries	E.269, 274-275
COB system for switch cabinet	E.286-289
Light and Sound applications with JEI®-P lever	E.298-299



CDSH 18 inserts max. current load derating diagram

CDSH 27

10 A 400 V

size **77.27**

27 poles + ⊕

Tool-less connection – SQUICH®

EN 61984 rating	10 A 400 V 6 kV 3
	10 A 400 / 690 V 6 kV 2
Rated voltage (UL / CSA)	600 V
Insulation resistance	≥ 10 GΩ
Contact resistance	≤ 3 mΩ
Ambient temperature limit	-40 °C ... +125 °C
Mechanical life (cycles)	≥ 500



ALUS ECBT2.E115072 | ECBT8.E115072

Item	Description	Part No.	Dimension
	Male inserts with male contacts Spring clamp connections, with actuator button	CDSHM 27	
	Female inserts with female contacts Spring clamp connections, with actuator button	CDSHF 27	

Materials

Insert	polycarbonate (PC)
UL 94 flame rating	V-0
Colour	pebble grey, RAL 7032
Contacts	built-in, copper alloy, silver ● plated

Wiring information

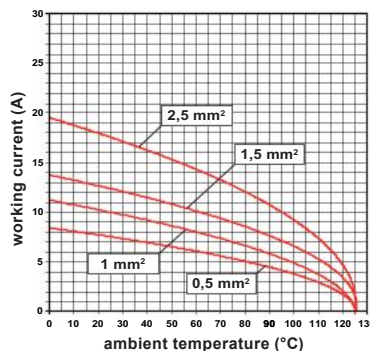
Wires cross sectional area	
- unprepared	0,14 mm ² - 2,5 mm ² (AWG 26-14)
- prepared	up to 1,5 mm ² (AWG 16)
Stripping length	9...11 mm



CR CDS
Coding pins
Page [6.10](#)

Enclosures size 77.27

Heavy-Duty Applications	Pages
Metallic with C-TYPE lever	E.62-69
Metallic with IL-BRID lever	E.96-99, 106
Metallic with JEI®-P lever	E.115-116, 119
Metallic with V-TYPE IP67 lever	E.126, 132-133
Thermoplastic T-TYPE	E.230-231, 234-235
Aggressive Environments	
Metallic IP68 high protection	E.146-147
Metallic W-TYPE	E.158-159, 164
Metallic E-Xtreme®	E.178-179, 186-187, 196
Thermoplastic T-TYPE/W	E.230-231, 234-235
Specialized Applications	
EMC (Electromagnetic Shielding)	E.212-213, 218
Hygienic series for food and beverage	E.246, 248
Standard applications with Central lever	E.258-259
BIG Enclosures for multiple cable entries	E.270, 276-277
COB system for switch cabinet	E.286-289
Light and Sound applications with JEI®-P lever	E.300-301



CDSH 27 inserts max. current load derating diagram

CDSH 42

10 A 400 V

size **104.27**

42 poles + ⊕


Tool-less connection – SQUICH®

EN 61984 rating	10 A 400 V 6 kV 3
	10 A 400 / 690 V 6 kV 2
Rated voltage (UL / CSA)	600 V
Insulation resistance	≥ 10 GΩ
Contact resistance	≤ 3 mΩ
Ambient temperature limit	-40 °C ... +125 °C
Mechanical life (cycles)	≥ 500

CE UK EAC



C A US ECBT2.E115072 | ECBT8.E115072

Item	Description	Part No.	Dimension
	Male inserts with male contacts Spring clamp connections, with actuator button	CDSHM 42	
	Female inserts with female contacts Spring clamp connections, with actuator button	CDSHF 42	

Materials

Insert	polycarbonate (PC)
UL 94 flame rating	V-0
Colour	pebble grey, RAL 7032
Contacts	built-in, copper alloy, silver ● plated

Wiring information

Wires cross sectional area	0,14 mm ² - 2,5 mm ² (AWG 26-14)
- unprepared	up to 1,5 mm ² (AWG 16)
- prepared	9...11 mm
Stripping length	



CR CDS
Coding pins
Page [6.10](#)

Enclosures size 104.27**Pages****Heavy-Duty Applications**

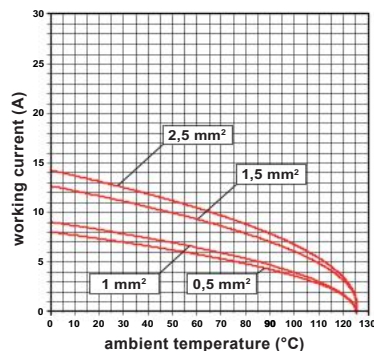
Metallic with C-TYPE lever	E.70-77
Metallic with IL-BRID lever	E.100-103 107
Metallic with JEI®-P lever	E.117-119
Metallic with V-TYPE IP67 lever	E.127 134-135
Thermoplastic T-TYPE	E.232-235

Aggressive Environments

Metallic IP68 high protection	E.148-149
Metallic W-TYPE	E.160-161 165
Metallic E-Xtreme®	E.180-181 188-189 197
Thermoplastic T-TYPE/W	E.232-235

Specialized Applications

EMC (Electromagnetic Shielding)	E.214-215 219
Hygienic series for food and beverage	E.247-248
Standard applications with Central lever	E.260-261
BIG Enclosures for multiple cable entries	E.271 278-279
COB system for switch cabinet	E.286-289
Light and Sound applications with JEI®-P lever	E.302-303



CDSH 42 inserts max. current load derating diagram

CDSH 27 + CDSH 27 N

10 A 400 V

size **77.62**


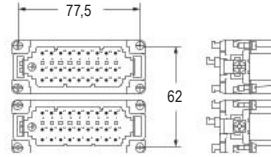

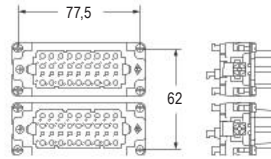
54 poles + ⊕

Tool-less connection – SQUICH®

EN 61984 rating	10 A 400 V 6 kV 3
	10 A 400 / 690 V 6 kV 2
Rated voltage (UL / CSA)	600 V
Insulation resistance	≥ 10 GΩ
Contact resistance	≤ 3 mΩ
Ambient temperature limit	-40 °C ... +125 °C
Mechanical life (cycles)	≥ 500



CAIUS ECBT2.E115072 | ECBT8.E115072

Item	Description	Part No.	Dimension
	Male inserts, No. (1-27) Male inserts, No. (28-54) Spring clamp connections, with actuator button	CDSHM 27 CDSHM 27 N	
	Female inserts, No. (1-27) Female inserts, No. (28-54) Spring clamp connections, with actuator button	CDSHF 27 CDSHF 27 N	


CDSH
B

Materials

Insert	polycarbonate (PC)
UL 94 flame rating	V-0
Colour	pebble grey, RAL 7032
Contacts	built-in, copper alloy, silver ● plated

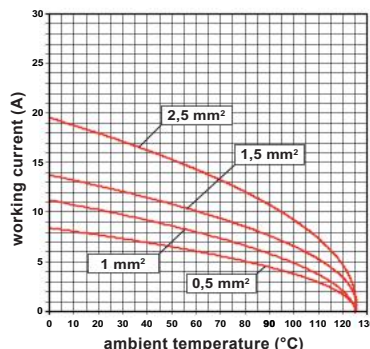
Wiring information

Wires cross sectional area	
- unprepared	0,14 mm ² - 2,5 mm ² (AWG 26-14)
- prepared	up to 1,5 mm ² (AWG 16)
Stripping length	9...11 mm



CR CDS
Coding pins
Page [6.10](#)

Enclosures size 77.62	Pages 10
Heavy-Duty Applications	
Metallic with C-TYPE lever	E.78-83
Aggressive Environments	
Metallic W-TYPE with C-TYPE lever	E.166-167
Metallic E-Xtreme® with C-TYPE lever	E.190-191



CDSH 27 inserts max. current load derating diagram

CDSH 42 + CDSH 42 N

10 A 400 V


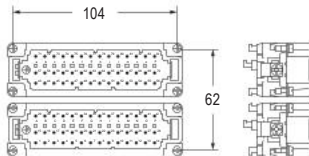

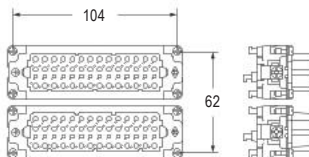
size **104.62****84 poles + ⊕****Tool-less connection – SQUICH®**

EN 61984 rating	10 A 400 V 6 kV 3
	10 A 400 / 690 V 6 kV 2
Rated voltage (UL / CSA)	600 V
Insulation resistance	≥ 10 GΩ
Contact resistance	≤ 3 mΩ
Ambient temperature limit	-40 °C ... +125 °C
Mechanical life (cycles)	≥ 500

CE UK EAC



C A U S E C B T 2 . E 1 1 5 0 7 2 | E C B T 8 . E 1 1 5 0 7 2

Item	Description	Part No.	Dimension
	Male inserts, No. (1-42) Male inserts, No. (43-84) Spring clamp connections, with actuator button	CDSHM 42 CDSHM 42 N	
	Female inserts, No. (1-42) Female inserts, No. (43-84) Spring clamp connections, with actuator button	CDSHF 42 CDSHF 42 N	

CDSH

B

Materials

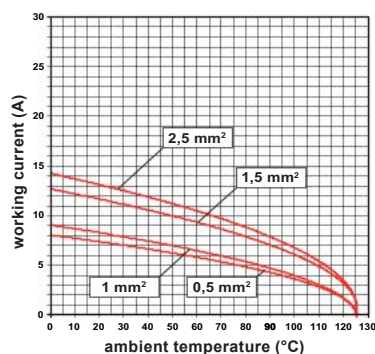
Insert	polycarbonate (PC)
UL 94 flame rating	V-0
Colour	pebble grey, RAL 7032
Contacts	built-in, copper alloy, silver ● plated

Wiring information

Wires cross sectional area	
- unprepared	0,14 mm ² - 2,5 mm ² (AWG 26-14)
- prepared	up to 1,5 mm ² (AWG 16)
Stripping length	9...11 mm



CR CDS
Coding pins
Page [3.10](#)

Enclosures size 104.62Pages [10](#)**Heavy-Duty Applications**Metallic with C-TYPE lever [E.84-85](#)**Aggressive Environments**Metallic W-TYPE with C-TYPE lever [E.168-169](#)Metallic E-Xtreme® with C-TYPE lever [E.192-193](#)**CDSH 42 inserts max. current load derating diagram**

CDSH 06 NC

6 A 250 V

size **44.27**

6 poles +

Tool-less connection – SQUICH®

EN 61984 rating	6 A 250 V 4 kV 3 6 A 500 V 4 kV 2 10 A with connector mated
Rated voltage (UL / CSA)	600 V
Insulation resistance	≥ 10 GΩ
Contact resistance	≤ 3 mΩ
Ambient temperature limit	-40 °C ... +125 °C
Mechanical life (cycles)	≥ 500



CEC® ECBT2.E115072 | ECBT8.E115072

Item	Description	Part No.	Dimension
	Male inserts with male contacts Spring clamp connections, with actuator button NC: Normally Closed	CDSHM 06 NC	
	Female inserts with NC shorting contacts Spring clamp connections, with actuator button NC: Normally Closed	CDSHF 06 NC	

Materials

Insert	polycarbonate (PC)
UL 94 flame rating	V-0
Colour	pebble grey, RAL 7032
Contacts	built-in, copper alloy, silver ● plated

Wiring information

Wires cross sectional area	
- unprepared	0,14 mm ² - 2,5 mm ² (AWG 26-14)
- prepared	up to 1,5 mm ² (AWG 16)
Stripping length	9...11 mm

CR CDS
Coding pins
Page G.10

Enclosures size 44.27

Heavy-Duty Applications

	Pages
Metallic with C-TYPE lever	E.48-53
Metallic with IL-BRID lever	E.90-91,104
Metallic with JEI®-P lever	E.112,119
Metallic with V-TYPE IP67 lever	E.124,128-129
Thermoplastic T-TYPE	E.226-227,234-235

Aggressive Environments

Metallic IP68 high protection	E.142-143
Metallic W-TYPE	E.154-155,162
Metallic E-Xtreme®	E.174-175,182-183,194
Thermoplastic T-TYPE/W	E.226-227,234-235

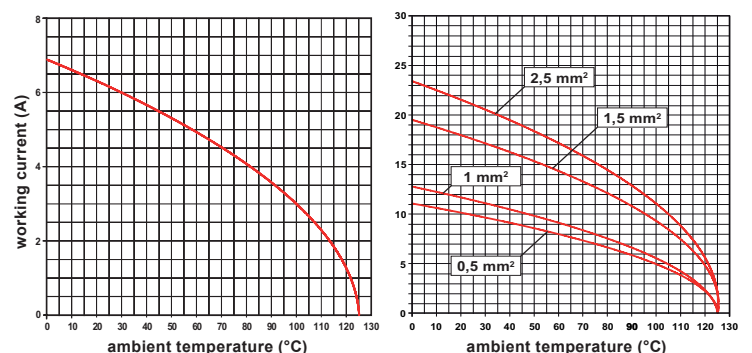
Specialized Applications

EMC (Electromagnetic Shielding)	E.208-209,216
Hygienic series for food and beverage	E.244,248
Standard applications with Central lever	E.254-255
BIG Enclosures for multiple cable entries	E.268,272-273
COB system for switch cabinet	E.286-289
Light and Sound applications with JEI®-P lever	E.296-297

The diagrams 1. and 2. below show the maximum current-carrying capacity:

1. AutoShort female connector uncoupled, with the three NC contacts that short circuit the individual circuits upstream wired in series on each contact pair. In this condition, the AutoShort connector can be loaded up to 6 A. For this maximum current it can be wired from 0,75 mm² / 18 AWG through 2,5 mm² / 14 AWG with no significant performance differences;
2. AutoShort female connector coupled to the male AutoShort connector (NC contacts open).

CDSH 06 NC inserts max. current load derating diagrams 1. and 2.



FOCUS

AUTOSHORT NC

ILME developed an **innovative connector suitable for interfacing measuring current transformers (CTs)** with the dedicated electronic measurement processing equipment. Use of such systems is increasing in transformer substations with the diffusion of smart grid concepts due to the growth of self-standing power generation plants (photovoltaic, wind).

The **CDSH..NC** connector has the **same dimensions of a 6 poles size 44.27 CSH connector**, and it is **easy to wire** thanks to ILME proprietary SQUICH® tool-less quick connection technology.

Inside the female insert, for each of the three contact pairs 1-2, 3-4 and 5-6, a **suitable spring element is foreseen**, providing a NC (normally closed) contact between the female contact pair. The said short-circuit element automatically establishes a short-circuit between the female contact pair while the connector is being unmated, before the complete withdrawal of the corresponding male connector.

This protects the measuring current transformer's secondary windings to which this connector is deemed to be wired, against the high voltage that would arise if the ends of each winding were left open while the primary winding (the power line busbars) are still under load.

Operating principles

CDSH...NC connector can be used only for connecting up to three secondary (output) windings of measuring current transformers to specific measuring circuits; on the female side each contact pair is provided with said AutoShort NC contact element **1** to keep the secondary winding ends shorted while the female connector is not engaged with the male connector, thus avoiding damages to the insulation of the current transformer and consequent hazardous condition for the personnel operating the unmating of the connector while the power busbars are energized. When the female and male connectors are being mated **2**, the short-circuit is released after proper electrical engagement of the two connector halves, thus allowing again current measurement by the dedicated electronic measurement processing equipment wired on the male connector side.

This connector inserts can be used in size 44.27 connector enclosures, either metal (conductive) or thermoplastics (insulating), with up to IP68 degree of protection (IP66 / IP68 with series CG / MG), within enclosures for aggressive environments (W-TYPE series) or with up to IP66 / IP69 within series T-TYPE HYGIENIC enclosures for hygienic applications.

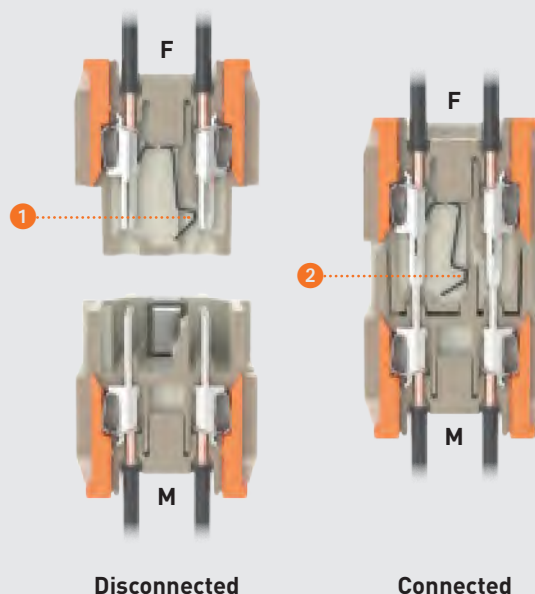
Pin assignment

Female inserts with NC shorting contacts between contacts of pairs 1-2, 3-4, 5-6, opening upon with male inserts. Pin assignment of contacts for the connector is the following:

Pin	Assignment
1	Winding 1 start
2	Winding 1 end
3	Winding 2 start
4	Winding 2 end
5	Winding 3 start
6	Winding 3 end
PE	⊕ Protective Earth



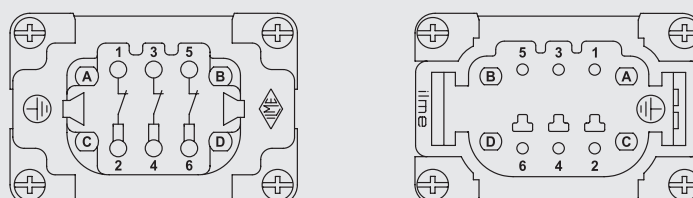
During the mating of these specially designed connector inserts, three corresponding actuator buttons realized on the mating face of the male connector, once the male contacts are already engaged with the corresponding female contact elements, push aside the facing end of the AutoShort NC contact element, in order to release the short-circuit previously provided. In mated condition the proper termination of the secondary windings of the CT must be provided by the customer's downstream circuit, e.g. by suitable resistors.



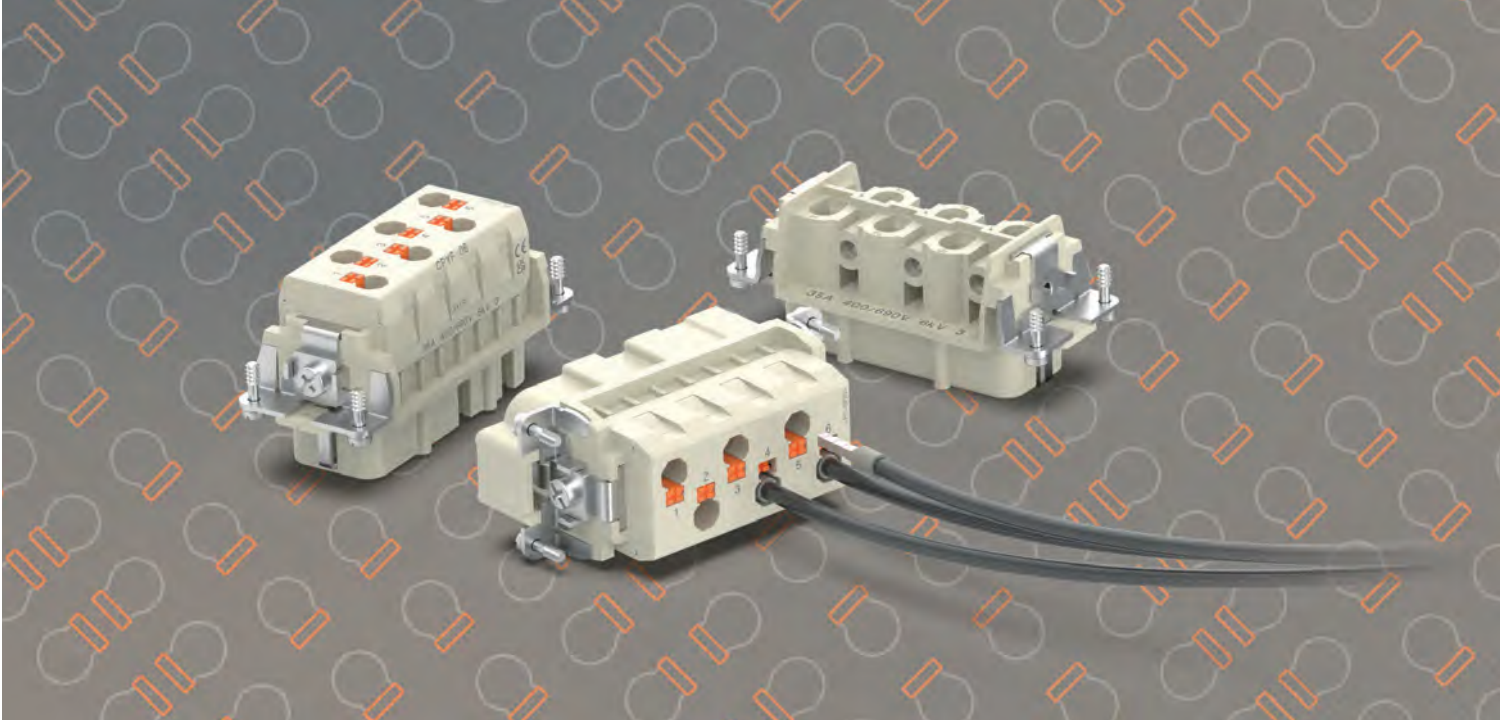
Disconnected

Connected

View from the contact side



CP screw-type and CPY **AXYR**[®] series



CPYF /M 06, CPYF /M 06 N

The **AXYR**[®] push-in tool-less spring clamp technology is implemented as push-in spring clamp variant of the traditional **series CP** connector inserts with screw-type terminals. The inserts are made available also in special pole numbering 7 through 12 (suffix **N** in the part no.) for combined 12-pole connectors in size 77.62 enclosures.

A typical 6-pole connector application is required to provide individual wiring (e.g., for remote star/delta configuration or for speed/torque control through PWM drives) of the winding ends of each phase of a 3-phase AC motor (e.g., up to 37 kW rated output power for a 400/690 V motor or up to 22 kW for a 230/400 V motor, based on the available current-carrying capacity of these new **CPYF /M 06** connectors).

Other applications known of these connectors are for feeding heating resistors for thermoplastic moulding, e.g. see EUROMAP 14-2.

This new **AXYR**[®] variant allows a faster and more secure wiring for those applications which are high demanding in terms of expected vibration and shock.

- > Suitable for prepared or unprepared stranded copper conductors (class 5) or for unprepared solid conductors (class 1);
- > wire cross-sectional area from 0,75 mm² / AWG 18 to 6 mm² / AWG 10;
- > stripping length = 9 ... 11 mm.

Solid wires or ferruled stranded wires can just be pushed into the relevant terminal, whereas stranded wires, duly compacted, need preliminary opening of the terminal by a push-in on the relevant actuator button with a flat screw-driver size 3 × 0,5 mm.

These inserts are backward compatible (interchangeable and intermateable) with the corresponding screw-type traditional version **CPF /M 06** and **CPF /M 06 N**, once not equipped with optional coding keys.

☑ NOTE – The special numbering models CPYF /M 06 N are of the same pebble grey RAL 7032 colour of the standard numbering (whereas traditional series CPF /M 06 N screw-type special numbering inserts are black-coloured).



FOCUS

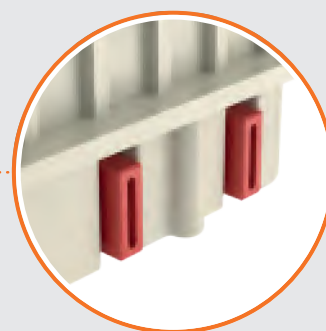
CR CPC coding pins

CR CPC coding pins, red-coloured, are separately available to differently code adjacent identical couplings. Up to 6 different codings possible, by equipping each

connector coupling of four pins in the corresponding seats on the contour of each connector half (two pins on each one). See relevant scheme.



▶ Up to 6 different codings possible.



CP 06

35 A 400/690 V

size **77.27**

6 poles + ⊕

Screw connection

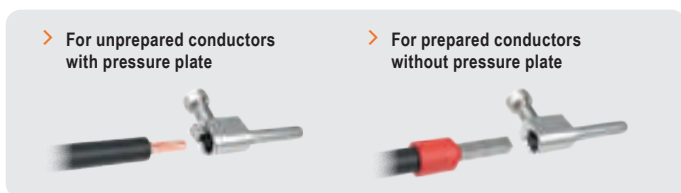
EN 61984 rating	35 A 400 / 690 V 6 kV 3
Rated voltage (UL / CSA)	600 V
Insulation resistance	≥ 10 GΩ
Contact resistance	≤ 0,5 mΩ
Ambient temperature limit	-40 °C ... +125 °C
Mechanical life (cycles)	≥ 500



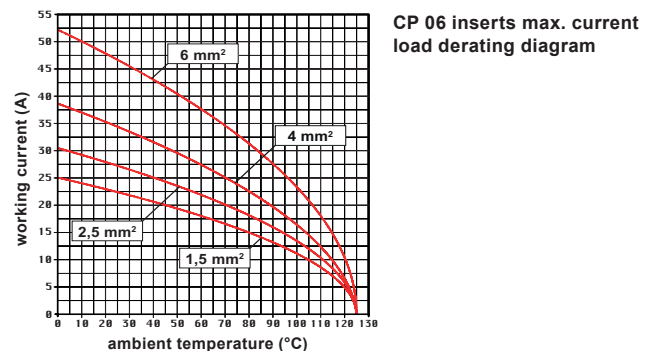
Item	Description	Part No.	Dimension
	Male inserts for male contacts With pressure plate for unprepared conductors	CPM 06	
	Male inserts for male contacts Without pressure plate for prepared conductors	CPM 06 X	
	Female inserts for female contacts With pressure plate for unprepared conductors	CPF 06	
	Female inserts for female contacts Without pressure plate for prepared conductors	CPF 06 X	

Materials	
Insert	polycarbonate (PC)
UL 94 flame rating	V-0
Colour	pebble grey, RAL 7032
Contacts	built-in, copper alloy, silver ● plated

Wiring information	
Wires cross sectional area	
- unprepared	0,75 mm ² - 6 mm ² (AWG 18-10)
- prepared	0,75 mm ² - 6 mm ² (AWG 18-10)
Stripping length	10,5 mm
Terminal screw torque	1,2 Nm (10.7 lb.in)



Enclosures size 77.27	Pages
Heavy-Duty Applications	
Metallic with C-TYPE lever	E.62-69
Metallic with IL-BRID lever	E.96-99, 106
Metallic with JEI®-P lever	E.115-116, 119
Metallic with V-TYPE IP67 lever	E.126, 132-133
Thermoplastic T-TYPE	E.230-231, 234-235
Aggressive Environments	
Metallic IP68 high protection	E.146-147
Metallic W-TYPE	E.158-159, 164
Metallic E-Xtreme®	E.178-179, 186-187, 196
Thermoplastic T-TYPE/W	E.230-231, 234-235
Specialized Applications	
EMC (Electromagnetic Shielding)	E.212-213, 218
Hygienic series for food and beverage	E.246, 248
Standard applications with Central lever	E.258-259
BIG Enclosures for multiple cable entries	E.270, 276-277
COB system for switch cabinet	E.286-289
Light and Sound applications with JEI®-P lever	E.300-301




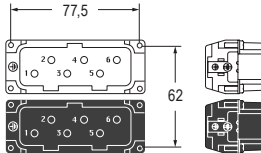

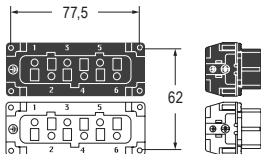
CP 06 + CP 06 N**35 A 400/690 V**size **77.62****12 poles + ⊕****Screw connection**

EN 61984 rating	35 A 400 / 690 V 6 kV 3
Rated voltage (UL / CSA)	600 V
Insulation resistance	≥ 10 GΩ
Contact resistance	≤ 0,5 mΩ
Ambient temperature limit	-40 °C ... +125 °C
Mechanical life (cycles)	≥ 500

CE UK EAC



ECBT2.E115072 | ECBT8.E115072

Item	Description	Part No.	Dimension
	Male inserts, No. (1-6), pebble grey Male inserts, No. (1-6), black With pressure plate for unprepared conductors	CPM 06 CPM 06 N	
	Female inserts, No. (1-6), pebble grey Female inserts, No. (1-6), black With pressure plate for unprepared conductors	CPF 06 CPF 06 N	

Materials

Insert	polycarbonate (PC)
UL 94 flame rating	V-0
Colour	
- CP...	pebble grey, RAL 7032
- CP...N	black, RAL 9005
Contacts	built-in, copper alloy, silver ● plated

Wiring information

Wires cross sectional area	0,75 mm ² - 6 mm ² (AWG 18-10)
Stripping length	10,5 mm
Terminal screw torque	1,2 Nm (10.7 lb.in)

➤ For unprepared conductors
with pressure plate

**Enclosures size 77.62**

Pages

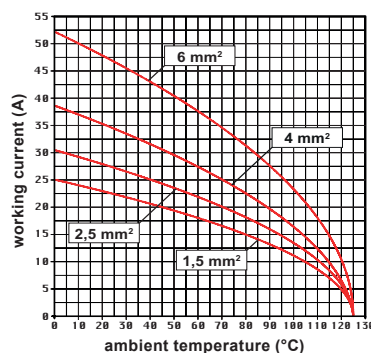
Heavy-Duty Applications

Metallic with C-TYPE lever E.78-83

Aggressive Environments

Metallic W-TYPE with C-TYPE lever E.166-167

Metallic E-Xtreme® with C-TYPE lever E.190-191

CP 06 inserts max. current
load derating diagram

CPY 06

35 A 400/690 V

size **77.27**

6 poles + ⊕


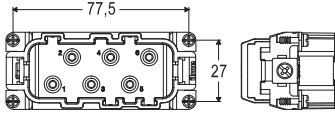

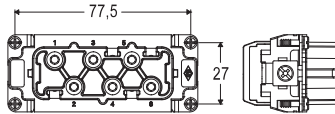
Tool-less connection – AXYR®

EN 61984 rating*	35 A 400 / 690 V 6 kV 3
Rated voltage (UL / CSA) (pending)	600 V
Insulation resistance	≥ 10 GΩ
Contact resistance	≤ 0,5 mΩ
Ambient temperature limit	-40 °C ... +125 °C
Mechanical life (cycles)	≥ 500

CE UK (pending: EAC)

(pending: CQC, DNV and BV)

(pending: cURus)

Item	Description	Part No.	Dimension
	Male inserts with male contacts Spring/AXYR® push-in connection * can be used at operating voltages up to 830 V 8 kV 3 provided they are coded with CR CPC to avoid mismatching with CPM / F 06	CPYM 06	
	Female inserts with female contacts Spring/AXYR® push-in connection * can be used at operating voltages up to 830 V 8 kV 3 provided they are coded with CR CPC to avoid mismatching with CPM / F 06	CPYF 06	

Materials

Insert	polycarbonate (PC)
UL 94 flame rating	V-0
Colour	pebble grey, RAL 7032
Contacts	built-in, copper alloy, silver ● plated

Wiring information

Wire cross sectional area	1,5 mm ² - 6 mm ² (AWG 16-10)
- unprepared	1,5 mm ² - 6 mm ² (AWG 16-10)
- prepared	1,5 mm ² - 6 mm ² (AWG 16-10)
Stripping length	9...11 mm

Wire diameter: up to 7 mm.



CR CPC
Coding pins
Page G.9

Enclosures size 77.27	Pages
Heavy-Duty Applications	
Metallic with C-TYPE lever	E.62-69
Metallic with IL-BRID lever	E.96-99,106
Metallic with JEI®-P lever	E.115-116,119
Metallic with V-TYPE IP67 lever	E.126,132-133
Thermoplastic T-TYPE	E.230-231,234-235
Aggressive Environments	
Metallic IP68 high protection	E.146-147
Metallic W-TYPE	E.158-159,164
Metallic E-Xtreme®	E.178-179,186-187,196
Thermoplastic T-TYPE/W	E.230-231,234-235
Specialized Applications	
EMC (Electromagnetic Shielding)	E.212-213,218
Hygienic series for food and beverage	E.246,248
Standard applications with Central lever	E.258-259
BIG Enclosures for multiple cable entries	E.270,276-277
COB system for switch cabinet	E.286-289
Light and Sound applications with JEI®-P lever	E.300-301

CPY 06 + CPY 06 N

35 A 400/690 V

size **77.62**

12 poles +


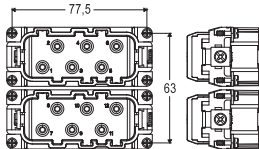

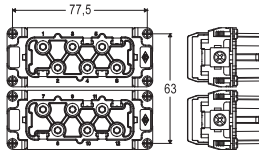
Tool-less connection – AXYR®

EN 61984 rating*	35 A 400 / 690 V 6 kV 3
Rated voltage (UL / CSA) (pending)	600 V
Insulation resistance	≥ 10 GΩ
Contact resistance	≤ 0,5 mΩ
Ambient temperature limit	-40 °C ... +125 °C
Mechanical life (cycles)	≥ 500

(pending: EAC)

(pending: CQC, DNV and BV)

(pending: cURus)

Item	Description	Part No.	Dimension
	Male inserts, No. (1-6) Male inserts, No. (7-12) Spring/AXYR® push-in connection * can be used at operating voltages up to 830 V 8 kV 3 provided they are coded with CR CPC to avoid mismatching with CPM / F 06	CPYM 06 CPYM 06 N	
	Female inserts, No. (1-6) Female inserts, No. (7-12) Spring/AXYR® push-in connection * can be used at operating voltages up to 830 V 8 kV 3 provided they are coded with CR CPC to avoid mismatching with CPM / F 06	CPYF 06 CPYF 06 N	

Materials

Insert	polycarbonate (PC)
UL 94 flame rating	V-0
Colour	pebble grey, RAL 7032
Contacts	built-in, copper alloy, silver ● plated

Wiring information

Wire cross sectional area	
- unprepared	1,5 mm ² - 6 mm ² (AWG 16-10)
- prepared	1,5 mm ² - 6 mm ² (AWG 16-10)
Stripping length	9...11 mm

Wire diameter: up to 7 mm.



CR CPC
Coding pins
Page G.9

Enclosures size 77.62

Pages

Heavy-Duty Applications

Metallic with C-TYPE lever E.78-83

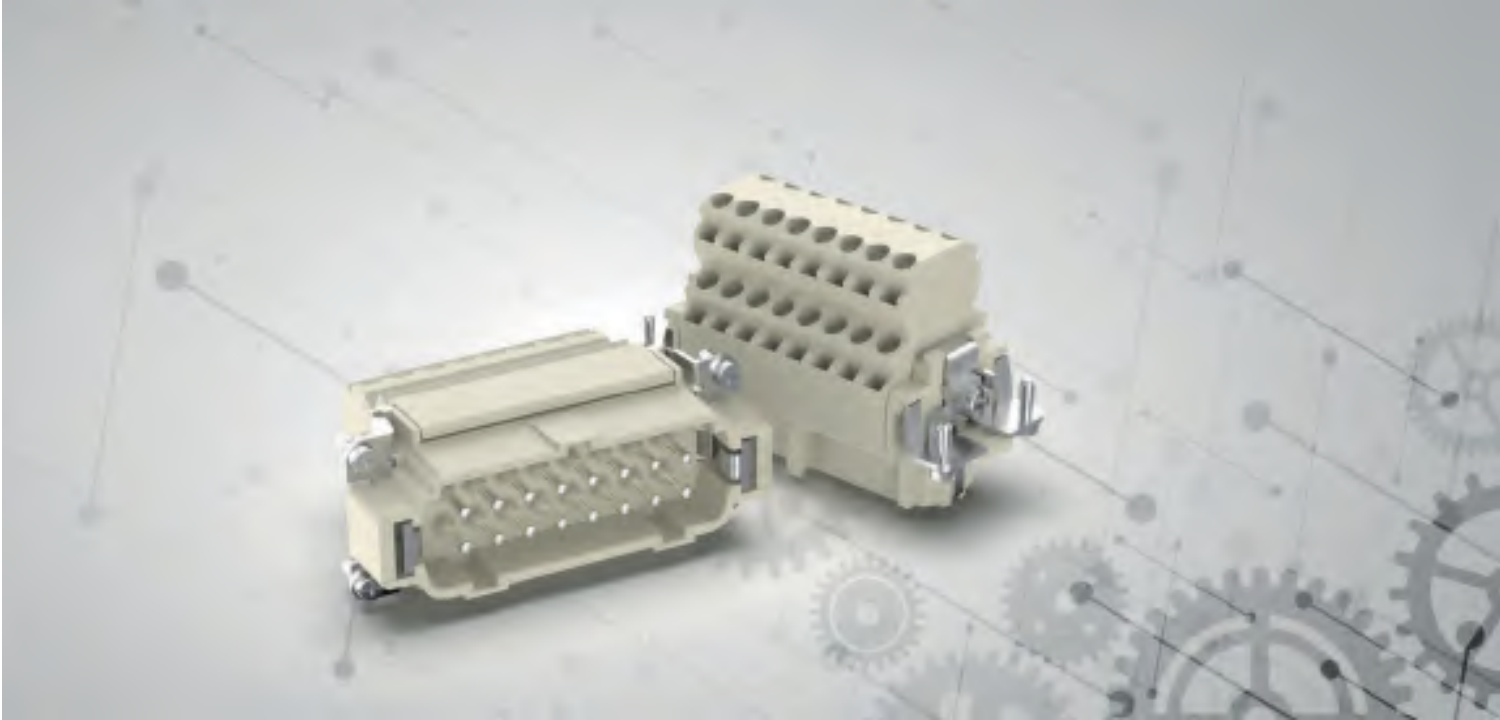
Aggressive Environments

Metallic W-TYPE with C-TYPE lever E.166-167

Metallic E-Xtreme® with C-TYPE lever E.190-191

CSS series

Connection with dual spring terminal per pole



The **CSS inserts** series feature two spring clamp terminals per contact, allowing two separate conductors to be wired to each connector pole.

CSS inserts share the mating interface (dimensions) with equally sized inserts of series **CNE** (screw-type), **CCE** (crimp type), **CSH** (spring type with actuator button SQUICH®), **CT** (screw-type with 45° terminal block) and **CTSE** spring-type with 45° terminal block).

CSS series overview

Electric motors can be prepared for the fastest and most reliable installation using the combination of CSS inserts and suitably developed housings, reducing downtime costs.

Star or Delta (triangle) bridges may be realized in the mating (free) female connector, realizing simple bridges thanks to the double terminals per pole feature of CSS, by short conductors stripped at both ends and "U-bent".

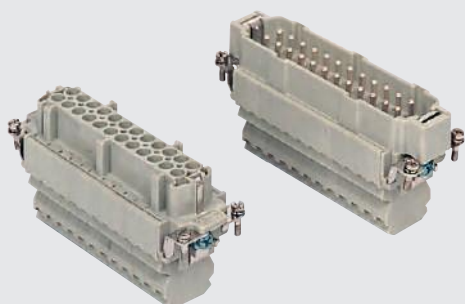
The motor terminal box may be replaced by the specially developed motor connection angled housing **CVI 10 LA** or **MVI 10 LAP32** (see page E.131).

CSS INSERTS SUM-UP

- > **Two spring clamp terminals per contact**
- > **No special tools are needed**
- > **Suitable for standard hoods / housings size 44.27, 57.27, 77.27, 77.62, 104.27, 104.62 high construction version**
- > **Vibration and shock resistant**
- > **Ideal as motor connectors, as they provide the possibility to connect motor windings in star and delta configuration**
- > **The 10 pole version is specified by *DESINA* Specifications and by ISO 23570-1:2009 as type 1 connector for motor connection (6 poles for three-phase star or delta connection + 2 poles for breaking circuit + 2 poles for temperature sensing motor protection circuit)**
- > **Built-in silver plated contacts**

FOCUS

DESINA standards and specifications for CSS series



- ✍ **DESINA** standards for **DE**centralized and **ST**andardized **IN**stallation **TE**chnology. This working group was founded by the Association of German Machine Tools Manufacturers (VDW) with the target to develop a field bus independent, standardized installation system for machines and production plants.

The task was fulfilled in close cooperation with machine tools manufacturers, the automotive industry and their supply chain.

DESINA specifications have been transferred to series **ISO 23570** international standards.

CSS 06


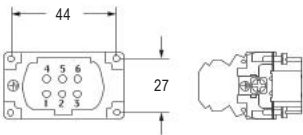

16 A 500 V

size **44.27**
6 poles + ⊕

Spring connection

EN 61984 rating	16 A 500 V 6 kV 3
	16 A 400 / 690 V 6 kV 2
Rated voltage (UL / CSA)	600 V
Insulation resistance	≥ 10 GΩ
Contact resistance	≤ 3 mΩ
Ambient temperature limit	-40 °C ... +125 °C
Mechanical life (cycles)	≥ 500



Item	Description	Part No.	Dimension
	Male inserts with male contacts Dual spring terminal per pole	CSSM 06	
	Female inserts with female contacts Dual spring terminal per pole	CSSF 06	

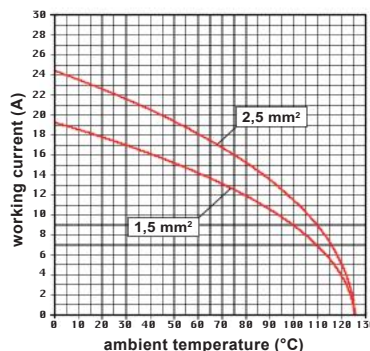
Materials

Insert	polycarbonate (PC)
UL 94 flame rating	V-0
Colour	pebble grey, RAL 7032
Contacts	built-in, copper alloy, silver ● plated

Wiring information

Wires cross sectional area	0,14 mm ² - 2,5 mm ² (AWG 26-14)
Stripping length	9...11 mm

Enclosures size 44.27	Pages
Heavy-Duty Applications	
Metallic with C-TYPE lever	E.48-53
Metallic with IL-BRID lever	E.90-91, 104
Metallic with JEI®-P lever	E.112, 119
Metallic with V-TYPE IP67 lever	E.124, 128-129
Thermoplastic T-TYPE	E.226-227, 234-235
Aggressive Environments	
Metallic IP68 high protection	E.142-143
Metallic W-TYPE	E.154-155, 162
Metallic E-Xtreme®	E.174-175, 182-183, 194
Thermoplastic T-TYPE/W	E.226-227, 234-235
Specialized Applications	
EMC (Electromagnetic Shielding)	E.208-209, 216
Hygienic series for food and beverage	E.244, 248
Standard applications with Central lever	E.254-255
BIG Enclosures for multiple cable entries	E.268, 272-273
COB system for switch cabinet	E.286-289
Light and Sound applications with JEI®-P lever	E.296-297



CSS 06 inserts max. current load derating diagram

- Can be used in bulkhead mounting housings or in high construction housings or in high construction hoods.
- Can be mated with CNE, CCE, CTSE and CSH inserts.

CSS 10

16 A 500 V

size **57.27**

10 poles + ⊕



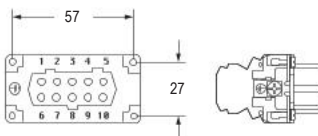
Spring connection

EN 61984 rating	16 A 500 V 6 kV 3
	16 A 400 / 690 V 6 kV 2
Rated voltage (UL / CSA)	600 V
Insulation resistance	≥ 10 GΩ
Contact resistance	≤ 3 mΩ
Ambient temperature limit	-40 °C ... +125 °C
Mechanical life (cycles)	≥ 500

CE UK EAC



ECBT2.E115072 | ECBT8.E115072

Item	Description	Part No.	Dimension
	Male inserts with male contacts Dual spring terminal per pole	CSSM 10	
	Female inserts with female contacts Dual spring terminal per pole	CSSF 10	

Materials

Insert	polycarbonate (PC)
UL 94 flame rating	V-0
Colour	pebble grey, RAL 7032
Contacts	built-in, copper alloy, silver ● plated

Wiring information

Wires cross sectional area	0,14 mm ² - 2,5 mm ² (AWG 26-14)
Stripping length	9...11 mm

Enclosures size 57.27

Pages

Heavy-Duty Applications

Metallic with C-TYPE lever	≡.54-61
Metallic with IL-BRID lever	≡.92-95 103
Metallic with JEI®-P lever	≡.113-114 119
Metallic with V-TYPE IP67 lever	≡.125 130-131
Thermoplastic T-TYPE	≡.228-229 234-235

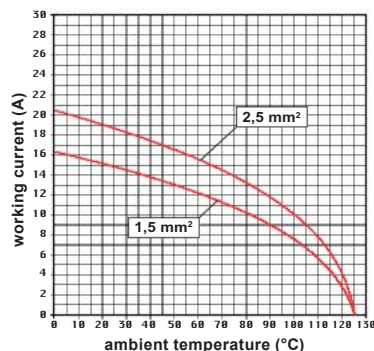
Aggressive Environments

Metallic IP68 high protection	≡.144-145
Metallic W-TYPE	≡.156-157 163
Metallic E-Xtreme®	≡.176-177 184-185 193
Thermoplastic T-TYPE/W	≡.228-229 234-235

Specialized Applications

EMC (Electromagnetic Shielding)	≡.210-211 217
Hygienic series for food and beverage	≡.245 248
Standard applications with Central lever	≡.256-257
BIG Enclosures for multiple cable entries	≡.269 274-275
COB system for switch cabinet	≡.286-289
Light and Sound applications with JEI®-P lever	≡.298-299

- Can be used in bulkhead mounting housings or in high construction housings or in high construction hoods.
- Can be mated with **CNE**, **CCE**, **CTSE** and **CSH** inserts.



CSS 10 inserts max. current load derating diagram

CSS 16

16 A 500 V

size **77.27**
16 poles + ⊕

Spring connection

EN 61984 rating	16 A 500 V 6 kV 3
	16 A 400 / 690 V 6 kV 2
Rated voltage (UL / CSA)	600 V
Insulation resistance	≥ 10 GΩ
Contact resistance	≤ 3 mΩ
Ambient temperature limit	-40 °C ... +125 °C
Mechanical life (cycles)	≥ 500



Item	Description	Part No.	Dimension
	Male inserts with male contacts Dual spring terminal per pole	CSSM 16	
	Female inserts with female contacts Dual spring terminal per pole	CSSF 16	

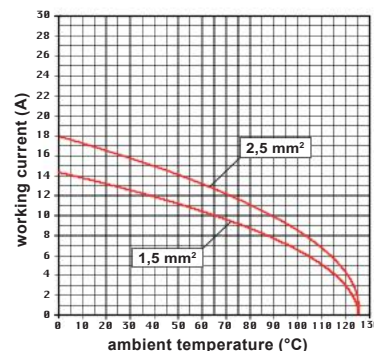
Materials

Insert	polycarbonate (PC)
UL 94 flame rating	V-0
Colour	pebble grey, RAL 7032
Contacts	built-in, copper alloy, silver ● plated

Wiring information

Wires cross sectional area	0,14 mm ² - 2,5 mm ² (AWG 26-14)
Stripping length	9...11 mm

Enclosures size 77.27	Pages
Heavy-Duty Applications	
Metallic with C-TYPE lever	E.62-69
Metallic with IL-BRID lever	E.96-99, 106
Metallic with JEI®-P lever	E.115-116, 119
Metallic with V-TYPE IP67 lever	E.126, 132-133
Thermoplastic T-TYPE	E.230-231, 234-235
Aggressive Environments	
Metallic IP68 high protection	E.146-147
Metallic W-TYPE	E.158-159, 164
Metallic E-Xtreme®	E.178-179, 186-187, 196
Thermoplastic T-TYPE/W	E.230-231, 234-235
Specialized Applications	
EMC (Electromagnetic Shielding)	E.212-213, 218
Hygienic series for food and beverage	E.246, 248
Standard applications with Central lever	E.258-259
BIG Enclosures for multiple cable entries	E.270, 276-277
COB system for switch cabinet	E.286-289
Light and Sound applications with JEI®-P lever	E.300-301



CSS 16 inserts max. current load derating diagram

- Can be used in bulkhead mounting housings or in high construction housings or in high construction hoods.
- Can be mated with CNE, CCE, CTSE and CSH inserts.

CSS 24

16 A 500 V

size **104.27**

24 poles + ⊕

Spring connection

EN 61984 rating	16 A 500 V 6 kV 3
	16 A 400 / 690 V 6 kV 2
Rated voltage (UL / CSA)	600 V
Insulation resistance	≥ 10 GΩ
Contact resistance	≤ 3 mΩ
Ambient temperature limit	-40 °C ... +125 °C
Mechanical life (cycles)	≥ 500

CE UK EAC

ECBT2.E115072 | ECBT8.E115072

Item	Description	Part No.	Dimension
	Male inserts with male contacts Dual spring terminal per pole	CSSM 24	
	Female inserts with female contacts Dual spring terminal per pole	CSSF 24	

Materials

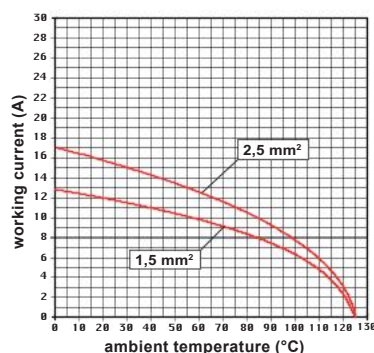
Insert	polycarbonate (PC)
UL 94 flame rating	V-0
Colour	pebble grey, RAL 7032
Contacts	built-in, copper alloy, silver ● plated

Wiring information

Wires cross sectional area	0,14 mm ² - 2,5 mm ² (AWG 26-14)
Stripping length	9...11 mm

Enclosures size 104.27	Pages
Heavy-Duty Applications	
Metallic with C-TYPE lever	E.70-77
Metallic with IL-BRID lever	E.100-103 107
Metallic with JEI®-P lever	E.117-119
Metallic with V-TYPE IP67 lever	E.127 134-135
Thermoplastic T-TYPE	E.232-235
Aggressive Environments	
Metallic IP68 high protection	E.148-149
Metallic W-TYPE	E.160-161 165
Metallic E-Xtreme®	E.180-181 188-189 197
Thermoplastic T-TYPE/W	E.232-235
Specialized Applications	
EMC (Electromagnetic Shielding)	E.214-215 219
Hygienic series for food and beverage	E.247-248
Standard applications with Central lever	E.260-261
BIG Enclosures for multiple cable entries	E.271 278-279
COB system for switch cabinet	E.286-289
Light and Sound applications with JEI®-P lever	E.302-303

- Can be used in bulkhead mounting housings or in high construction housings or in high construction hoods.
- Can be mated with **CNE**, **CCE**, **CTSE** and **CSH** inserts.



CSS 24 inserts max. current load derating diagram



CSS 16 + CSS 16 N

16 A 500 V

size **77.62**


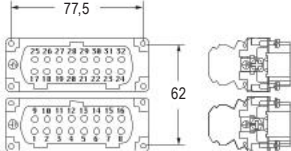

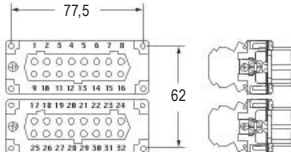
32 poles +

Spring connection

EN 61984 rating	16 A 500 V 6 kV 3
	16 A 400 / 690 V 6 kV 2
Rated voltage (UL / CSA)	600 V
Insulation resistance	≥ 10 GΩ
Contact resistance	≤ 3 mΩ
Ambient temperature limit	-40 °C ... +125 °C
Mechanical life (cycles)	≥ 500



ECBT2.E115072 | ECBT8.E115072

Item	Description	Part No.	Dimension
	Male inserts, No. (1-16) Male inserts, No. (17-32) Dual spring terminal per pole	CSSM 16 CSSM 16 N	
	Female inserts, No. (1-16) Female inserts, No. (17-32) Dual spring terminal per pole	CSSF 16 CSSF 16 N	

Materials

Insert	polycarbonate (PC)
UL 94 flame rating	V-0
Colour	pebble grey, RAL 7032
Contacts	built-in, copper alloy, silver ● plated

Wiring information

Wires cross sectional area	0,14 mm ² - 2,5 mm ² (AWG 26-14)
Stripping length	9...11 mm

Enclosures size 77.62

Pages

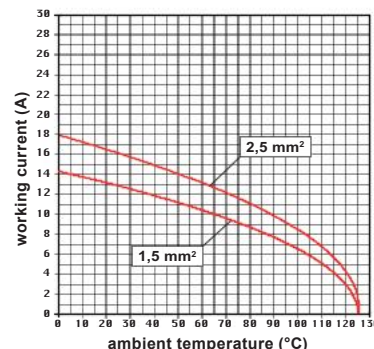
Heavy-Duty Applications

Metallic with C-TYPE lever	E.78-83
----------------------------	-------------------------

Aggressive Environments

Metallic W-TYPE with C-TYPE lever	E.166-167
Metallic E-Xtreme® with C-TYPE lever	E.190-191

CSS 16 inserts max. current load derating diagram



- Can be used in bulkhead mounting housings or in high construction housings or in high construction hoods.
- Can be mated with CNE, CCE, CTSE and CSH inserts.

CSS 24 + CSS 24 N

16 A 500 V

size **104.62**


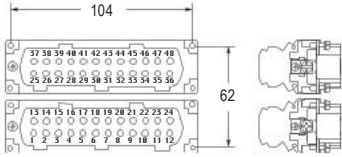

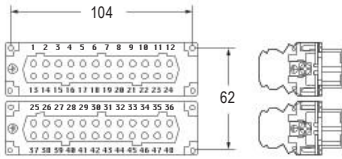
48 poles + ⊕

Spring connection

EN 61984 rating	16 A 500 V 6 kV 3
	16 A 400 / 690 V 6 kV 2
Rated voltage (UL / CSA)	600 V
Insulation resistance	≥ 10 GΩ
Contact resistance	≤ 3 mΩ
Ambient temperature limit	-40 °C ... +125 °C
Mechanical life (cycles)	≥ 500

CE UK EAC

ECBT2.E115072 | ECBT8.E115072

Item	Description	Part No.	Dimension
	Male inserts, No. (1-24) Male inserts, No. (25-48) Dual spring terminal per pole	CSSM 24 CSSM 24 N	
	Female inserts, No. (1-24) Female inserts, No. (25-48) Dual spring terminal per pole	CSSF 24 CSSF 24 N	

CSS

B

Materials

Insert	polycarbonate (PC)
UL 94 flame rating	V-0
Colour	pebble grey, RAL 7032
Contacts	built-in, copper alloy, silver ● plated

Wiring information

Wires cross sectional area	0,14 mm ² - 2,5 mm ² (AWG 26-14)
Stripping length	9...11 mm

Enclosures size 104.62

Pages

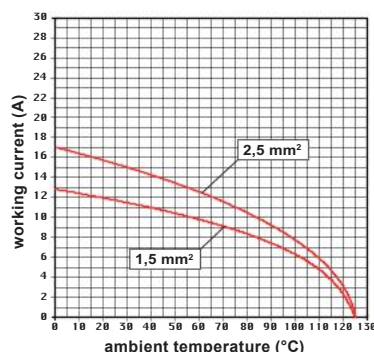
Heavy-Duty Applications

Metallic with C-TYPE lever	E.84-88
----------------------------	-------------------------

Aggressive Environments

Metallic W-TYPE with C-TYPE lever	E.168-169
Metallic E-Xtreme® with C-TYPE lever	E.192-193

- Can be used in bulkhead mounting housings or in high construction housings or in high construction hoods.
- Can be mated with CNE, CCE, CTSE and CSH inserts.



CSS 24 inserts max. current load derating diagram

CT / CTSE series. Inserts with incorporated terminal block for multipole connectors (16 A max versions)



CT-CTSE series overview

45° CT-CTSE series multipole connectors (with incorporated terminal block) are recommended for greater cost-saving and safety for use on machines and command and control panels.

- > The **CT-CTSE series inserts** (16 A max versions) are supplied in the plug or socket versions and may be mounted with insertion from the front of the enclosure (**Figure 1** for all the polarities of the inserts) or with insertion from the rear of the enclosure (**Figure 2**, only for 16 and 24-pole inserts).
- > As an alternative to the traditional terminal blocks, the inserts can be mounted inside the control panels on DIN EN rails (**Figure 5**) using suitable accessories providing the added advantage of easy sectioning.
- > The special structure of the CT - CTSE inserts has all the conductor connections on the same side providing for easier wiring and a complete view of the work area. The terminal block has also slots for housing the identification wire markers of each contact.
- > Wire markers of different manufacturers may be used such as: Cabur, Grafoplast, Modernotecnica, Phoenix Contact, Siemens, Wago, Weidmüller.
- > The **CT-CTSE series** is available in the versions "left" and "right" for mounting on the left (**Figure 3**) or on the right (**Figure 4**) of the control panel walls. This characteristic is determined by the position of contact "1" and the ground terminal in the upper part of the insert terminal block for both left and right mounting.
- > The installation of inserts on DIN rails (**Figure 5**) inside the control panels is usually made to facilitate the wiring into sectionable parts. In this case the degree of protection for coupled connectors is IP20 (in accordance with EN 60529). This type of mounting requires supports (**CT APE**) suitable for mounting on DIN EN 60715 rails.
- > Furthermore, to ensure a stable and secure mating between the CT and CTSE inserts installed on DIN rails and counterparts CNE, CCE, CSH, CSS mating screws **CRBF** (female) and **CRBM** (male) are recommended, to replace the ordinary fastening screws to the enclosures (**Figure 5**).

FOCUS

Inserts with incorporated 45° terminal block

- > The insert is inserted into the bulkhead housing without wired conductors or with pre-wired conductors that are not connected at the opposite end.
- > Mounting for inserts of 06, 10, 16 and 24 poles



Figure 1
Front mounting

- > The insert is inserted into the bulkhead housing with pre-wired conductors connected at the opposite end.
- > Mounting for inserts of 16 and 24 poles
- > Except version T-TYPE



Figure 2
Rear mounting

Figure 3
Left mounting

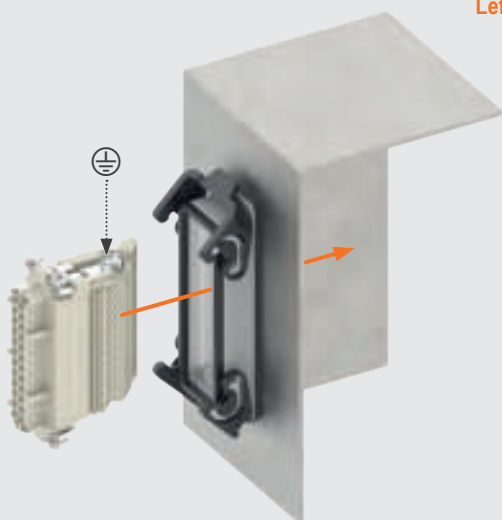


Figure 4
Right mounting

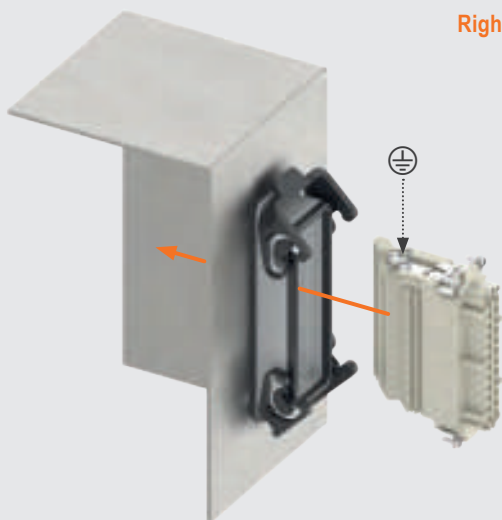
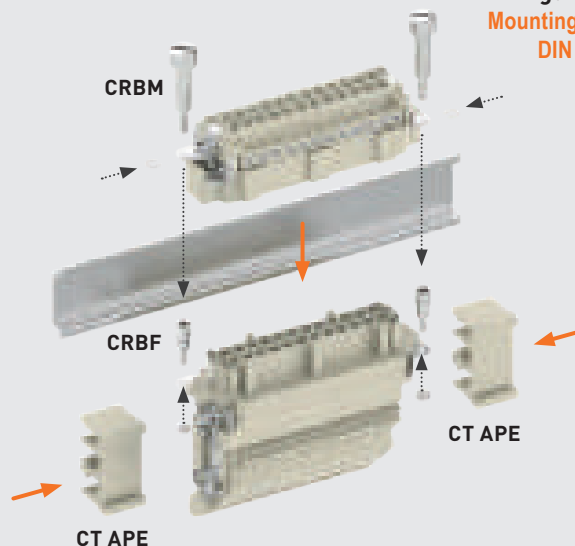


Figure 5
Mounting on
DIN rail

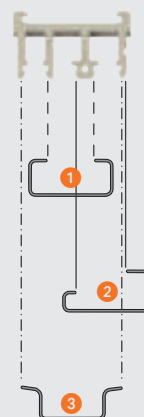
**CT APE**

Possibility of coupling to DIN EN 60715 rail (for a greater stability of the CT, CTSE inserts of 16 and 24 poles we recommend using the two CT APE supports)

- 1 EN 60715 C 30
- 2 EN 60715 G 32
- 3 EN 60715 TH 35-7,5 and TH 35-15

Accessories for CT inserts

- > support for mounting on DIN rail **CT APE**
- > inserts coupling screws **CRBM** and **CRBF**
- > cable-clamping plates **CRAD** and **CRAS**



CT 06

16 A 500 V

size **44.27**
6 poles + ⊕

Screw connection

EN 61984 rating	16 A 230 / 400 V 4 kV 3
	16 A 400 V 4 kV 2
Rated voltage (UL / CSA)	600 V
Insulation resistance	≥ 10 GΩ
Contact resistance	≤ 4 mΩ
Ambient temperature limit	-40 °C ... +125 °C
Mechanical life (cycles)	≥ 500



ECBT2.E115072 | ECBT8.E115072

Item	Description	Part No.	Dimension
	Male inserts with male contacts Screw terminal connection Mounting side: left	CTM 06 L	
	Male inserts with male contacts Screw terminal connection Mounting side: right	CTM 06 R	
	Female inserts with female contacts Screw terminal connection Mounting side: left	CTF 06 L	
	Female inserts with female contacts Screw terminal connection Mounting side: right	CTF 06 R	

Materials

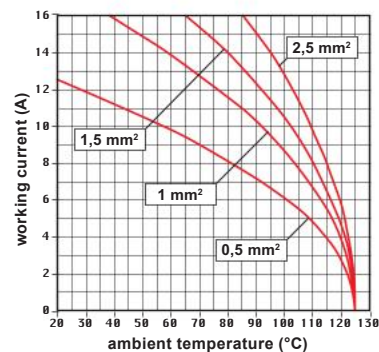
Insert	polycarbonate (PC)
UL 94 flame rating	V-0
Colour	pebble grey, RAL 7032
Contacts	built-in, copper alloy, silver ● plated

Wiring information

Wires cross sectional area	0,75 mm ² - 2,5 mm ² (AWG 18-14)
unprepared	12 mm
Stripping length	12 mm
Terminal screw torque	0,4 Nm (3.54 lb.in)

Enclosures size 44.27

	Pages
Heavy-Duty Applications	
Metallic with C-TYPE lever	E.48-53
Metallic with IL-BRID lever	E.90-91 , 104
Metallic with JEI®-P lever	E.112 , 119
Metallic with V-TYPE IP67 lever	E.124 , 128-129
Aggressive Environments	
Metallic IP68 high protection	E.142-143
Metallic W-TYPE	E.154-155 , 162
Metallic E-Xtreme®	E.174-175 , 182-183 , 194
Specialized Applications	
EMC (Electromagnetic Shielding)	E.208-209 , 216
Standard applications with Central lever	E.254-255
Light and Sound applications with JEI®-P lever	E.296-297



CT 06 inserts max. current load derating diagram

- Can be used only in bulkhead mounting housing;
- can be mated with CNE, CCE, CSH and CSS 06 inserts;
- rear-mounted inserts.

CT 10

16 A 500 V

size **57.27**

10 poles + ⊕


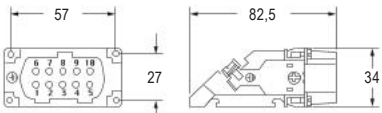

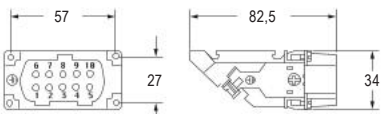

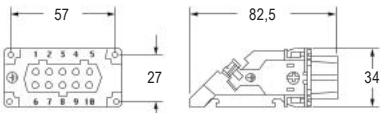

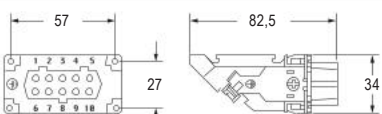
Screw connection

EN 61984 rating	16 A 230 / 400 V 4 kV 3
	16 A 400 V 4 kV 2
Rated voltage (UL / CSA)	600 V
Insulation resistance	≥ 10 GΩ
Contact resistance	≤ 4 mΩ
Ambient temperature limit	-40 °C ... +125 °C
Mechanical life (cycles)	≥ 500

CE UK EAC



ECBT2.E115072 | ECBT8.E115072

Item	Description	Part No.	Dimension
	Male inserts with male contacts Screw terminal connection Mounting side: left	CTM 10 L	
	Male inserts with male contacts Screw terminal connection Mounting side: right	CTM 10 R	
	Female inserts with female contacts Screw terminal connection Mounting side: left	CTF 10 L	
	Female inserts with female contacts Screw terminal connection Mounting side: right	CTF 10 R	

Materials

Insert	polycarbonate (PC)
UL 94 flame rating	V-0
Colour	pebble grey, RAL 7032
Contacts	built-in, copper alloy, silver ● plated

Wiring information

Wires cross sectional area	0,75 mm ² - 2,5 mm ² (AWG 18-14)
unprepared	12 mm
Stripping length	12 mm
Terminal screw torque	0,4 Nm (3.54 lb.in)

Enclosures size 57.27**Pages****Heavy-Duty Applications**

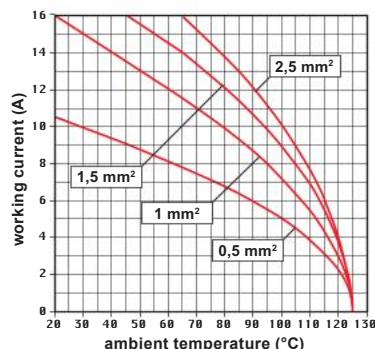
Metallic with C-TYPE lever	E.54-61
Metallic with IL-BRID lever	E.92-95 , 105
Metallic with JEI®-P lever	E.113-114 , 119
Metallic with V-TYPE IP67 lever	E.125 , 130-131

Aggressive Environments

Metallic IP68 high protection	E.144-145
Metallic W-TYPE	E.156-157 , 163
Metallic E-Xtreme®	E.176-177 , 184-185 , 195

Specialized Applications

EMC (Electromagnetic Shielding)	E.210-211 , 217
Standard applications with Central lever	E.256-257
Light and Sound applications with JEI®-P lever	E.298-299



CT 10 inserts max. current load derating diagram

- Can be used only in bulkhead mounting housing;
- can be mated with CNE, CCE, CSH and CSS 10 inserts;
- rear-mounted inserts.

CT 16

16 A 500 V


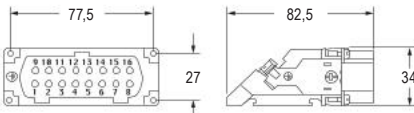

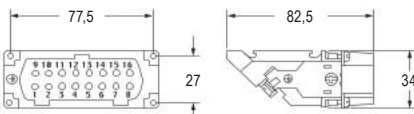

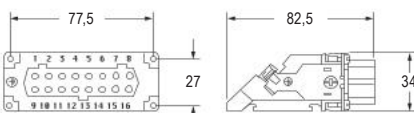

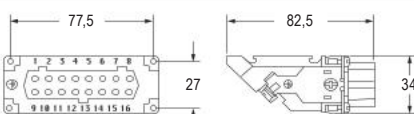
size **77.27**
16 poles + ⊕

Screw connection

EN 61984 rating	16 A 230 / 400 V 4 kV 3
	16 A 400 V 4 kV 2
Rated voltage (UL / CSA)	600 V
Insulation resistance	≥ 10 GΩ
Contact resistance	≤ 4 mΩ
Ambient temperature limit	-40 °C ... +125 °C
Mechanical life (cycles)	≥ 500



ECBT2.E115072 | ECBT8.E115072

Item	Description	Part No.	Dimension
	Male inserts with male contacts Screw terminal connection Mounting side: left	CTM 16 L	
	Male inserts with male contacts Screw terminal connection Mounting side: right	CTM 16 R	
	Female inserts with female contacts Screw terminal connection Mounting side: left	CTF 16 L	
	Female inserts with female contacts Screw terminal connection Mounting side: right	CTF 16 R	

Materials

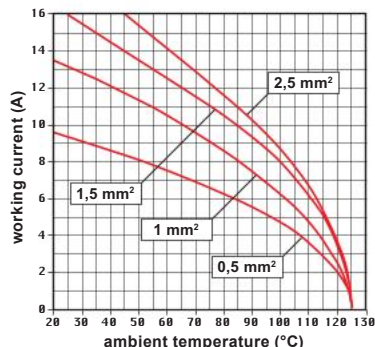
Insert	polycarbonate (PC)
UL 94 flame rating	V-0
Colour	pebble grey, RAL 7032
Contacts	built-in, copper alloy, silver ● plated

Wiring information

Wires cross sectional area	0,75 mm ² - 2,5 mm ² (AWG 18-14)
unprepared	12 mm
Stripping length	12 mm
Terminal screw torque	0,4 Nm (3.54 lb.in)

Enclosures size 77.27

Pages	
Heavy-Duty Applications	
Metallic with C-TYPE lever	E.62-69
Metallic with IL-BRID lever	E.96-99, 106
Metallic with JEI®-P lever	E.115-116, 119
Metallic with V-TYPE IP67 lever	E.126, 132-133
Aggressive Environments	
Metallic IP68 high protection	E.146-147
Metallic W-TYPE	E.158-159, 164
Metallic E-Xtreme®	E.178-179, 186-187, 196
Specialized Applications	
EMC (Electromagnetic Shielding)	E.212-213, 218
Standard applications with Central lever	E.258-259
Light and Sound applications with JEI®-P lever	E.300-301



CT 16 inserts max. current load derating diagram

- Can be used only in bulkhead mounting housing;
- can be mated with CNE, CCE, CSH and CSS 16 inserts;
- rear-mounted inserts.

CT 24

16 A 500 V

size **104.27**

24 poles + ⊕


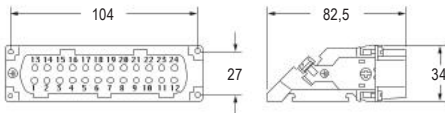

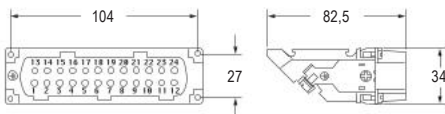

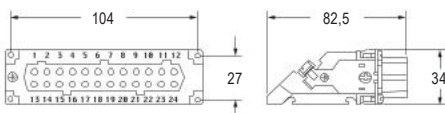

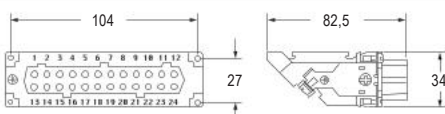
Screw connection

EN 61984 rating	16 A 230 / 400 V 4 kV 3
	16 A 400 V 4 kV 2
Rated voltage (UL / CSA)	600 V
Insulation resistance	≥ 10 GΩ
Contact resistance	≤ 4 mΩ
Ambient temperature limit	-40 °C ... +125 °C
Mechanical life (cycles)	≥ 500

CE UK EAC



ECBT2.E115072 | ECBT8.E115072

Item	Description	Part No.	Dimension
	Male inserts with male contacts Screw terminal connection Mounting side: left	CTM 24 L	
	Male inserts with male contacts Screw terminal connection Mounting side: right	CTM 24 R	
	Female inserts with female contacts Screw terminal connection Mounting side: left	CTF 24 L	
	Female inserts with female contacts Screw terminal connection Mounting side: right	CTF 24 R	

Materials

Insert	polycarbonate (PC)
UL 94 flame rating	V-0
Colour	pebble grey, RAL 7032
Contacts	built-in, copper alloy, silver ● plated

Wiring information

Wires cross sectional area	unprepared	0,75 mm ² - 2,5 mm ² (AWG 18-14)
Stripping length		12 mm
Terminal screw torque		0,4 Nm (3.54 lb.in)

Enclosures size 104.27**Pages****Heavy-Duty Applications**

Metallic with C-TYPE lever	E.70-77
Metallic with IL-BRID lever	E.100-103 107
Metallic with JEI®-P lever	E.117-119
Metallic with V-TYPE IP67 lever	E.127 134-135

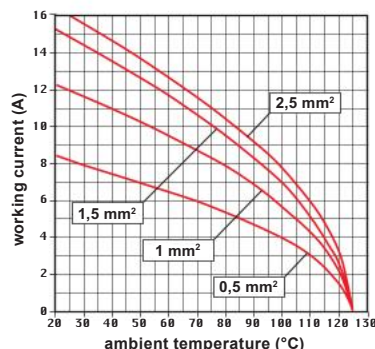
Aggressive Environments

Metallic IP68 high protection	E.148-149
Metallic W-TYPE	E.160-161 165
Metallic E-Xtreme®	E.180-181 188-189 197

Specialized Applications

EMC (Electromagnetic Shielding)	E.214-215 219
Standard applications with Central lever	E.260-261
Light and Sound applications with JEI®-P lever	E.302-303

- Can be used only in bulkhead mounting housing;
- can be mated with CNE, CCE, CSH and CSS 24 inserts;
- rear-mounted inserts.



CT 24 inserts max. current load derating diagram

CTSE 06

16 A 500 V

size **44.27**


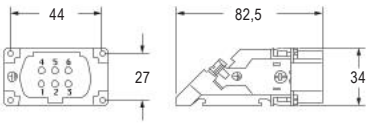

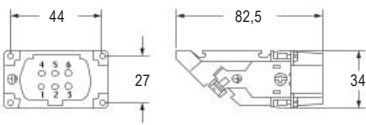

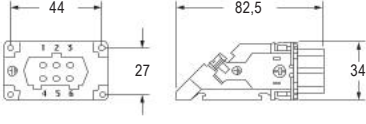

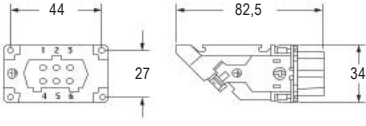
6 poles + ⊕

Spring connection

EN 61984 rating	16 A 500 V 6 kV 3
	16 A 400 / 690 V 6 kV 2
Rated voltage (UL / CSA)	600 V
Insulation resistance	≥ 10 GΩ
Contact resistance	≤ 4 mΩ
Ambient temperature limit	-40 °C ... +125 °C
Mechanical life (cycles)	≥ 500



ECBT2.E115072 | ECBT8.E115072

Item	Description	Part No.	Dimension
	Male inserts with male contacts Spring terminal connection Mounting side: left	CTSEM 06 L	
	Male inserts with male contacts Spring terminal connection Mounting side: right	CTSEM 06 R	
	Female inserts with female contacts Spring terminal connection Mounting side: left	CTSEF 06 L	
	Female inserts with female contacts Spring terminal connection Mounting side: right	CTSEF 06 R	

Materials

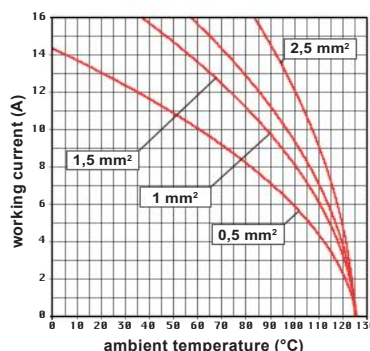
Insert	polycarbonate (PC)
UL 94 flame rating	V-0
Colour	pebble grey, RAL 7032
Contacts	built-in, copper alloy, silver ● plated

Wiring information

Wires cross sectional area	0,14 mm ² - 2,5 mm ² (AWG 26-14)
Stripping length	9...11 mm

Enclosures size 44.27

	Pages
Heavy-Duty Applications	
Metallic with C-TYPE lever	E.48-53
Metallic with IL-BRID lever	E.90-91, 104
Metallic with JEI®-P lever	E.112, 119
Metallic with V-TYPE IP67 lever	E.124, 128-129
Aggressive Environments	
Metallic IP68 high protection	E.142-143
Metallic W-TYPE	E.154-155, 162
Metallic E-Xtreme®	E.174-175, 182-183, 194
Specialized Applications	
EMC (Electromagnetic Shielding)	E.208-209, 216
Standard applications with Central lever	E.254-255
Light and Sound applications with JEI®-P lever	E.296-297



CTSE 06 inserts max. current load derating diagram

- Can be used only in bulkhead mounting housing;
- can be mated with CNE, CCE, CSH and CSS 06 inserts;
- rear-mounted inserts.

CTSE 10

16 A 500 V

size **57.27**


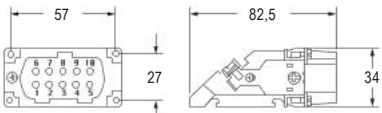

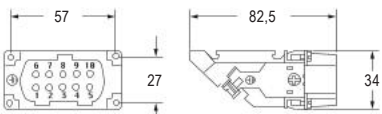

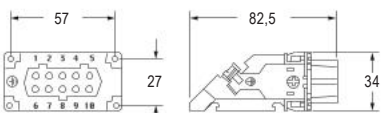

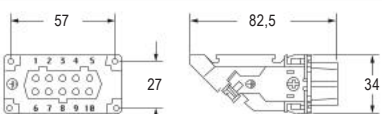
10 poles + ⊕

Spring connection

EN 61984 rating	16 A 500 V 6 kV 3
	16 A 400 / 690 V 6 kV 2
Rated voltage (UL / CSA)	600 V
Insulation resistance	≥ 10 GΩ
Contact resistance	≤ 4 mΩ
Ambient temperature limit	-40 °C ... +125 °C
Mechanical life (cycles)	≥ 500

CE UK EAC

ECBT2.E115072 | ECBT8.E115072

Item	Description	Part No.	Dimension
	Male inserts with male contacts Spring terminal connection Mounting side: left	CTSEM 10 L	
	Male inserts with male contacts Spring terminal connection Mounting side: right	CTSEM 10 R	
	Female inserts with female contacts Spring terminal connection Mounting side: left	CTSEF 10 L	
	Female inserts with female contacts Spring terminal connection Mounting side: right	CTSEF 10 R	

Materials

Insert	polycarbonate (PC)
UL 94 flame rating	V-0
Colour	pebble grey, RAL 7032
Contacts	built-in, copper alloy, silver ● plated

Wiring information

Wires cross sectional area	0,14 mm ² - 2,5 mm ² (AWG 26-14)
Stripping length	9...11 mm

Enclosures size 57.27**Pages****Heavy-Duty Applications**

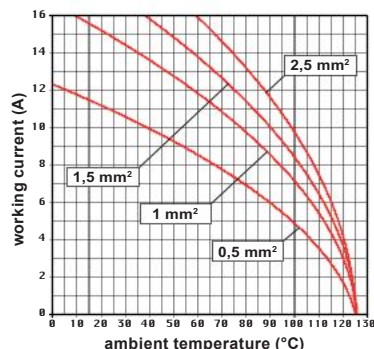
Metallic with C-TYPE lever	E.54-61
Metallic with IL-BRID lever	E.92-95 , 105
Metallic with JEI®-P lever	E.113-114 , 119
Metallic with V-TYPE IP67 lever	E.125 , 130-131

Aggressive Environments

Metallic IP68 high protection	E.144-145
Metallic W-TYPE	E.156-157 , 163
Metallic E-Xtreme®	E.176-177 , 184-185 , 195

Specialized Applications

EMC (Electromagnetic Shielding)	E.210-211 , 217
Standard applications with Central lever	E.256-257
Light and Sound applications with JEI®-P lever	E.298-299

**CTSE 10 inserts max. current load derating diagram**

- Can be used only in bulkhead mounting housing;
- can be mated with **CNE**, **CCE**, **CSH** and **CSS 10** inserts;
- rear-mounted inserts.

CTSE 16

16 A 500 V

size **77.27**


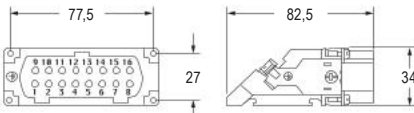

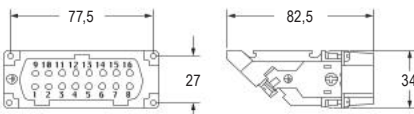

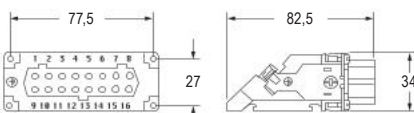

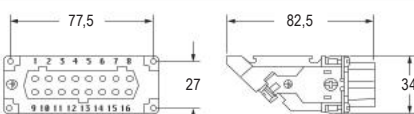
16 poles + ⊕

Spring connection

EN 61984 rating	16 A 500 V 6 kV 3
	16 A 400 / 690 V 6 kV 2
Rated voltage (UL / CSA)	600 V
Insulation resistance	≥ 10 GΩ
Contact resistance	≤ 4 mΩ
Ambient temperature limit	-40 °C ... +125 °C
Mechanical life (cycles)	≥ 500



ECBT2.E115072 | ECBT8.E115072

Item	Description	Part No.	Dimension
	Male inserts with male contacts Spring terminal connection Mounting side: left	CTSEM 16 L	
	Male inserts with male contacts Spring terminal connection Mounting side: right	CTSEM 16 R	
	Female inserts with female contacts Spring terminal connection Mounting side: left	CTSEF 16 L	
	Female inserts with female contacts Spring terminal connection Mounting side: right	CTSEF 16 R	

Materials

Insert	polycarbonate (PC)
UL 94 flame rating	V-0
Colour	pebble grey, RAL 7032
Contacts	built-in, copper alloy, silver ● plated

Wiring information

Wires cross sectional area	0,14 mm ² - 2,5 mm ² (AWG 26-14)
Stripping length	9...11 mm

Enclosures size 77.27

Heavy-Duty Applications

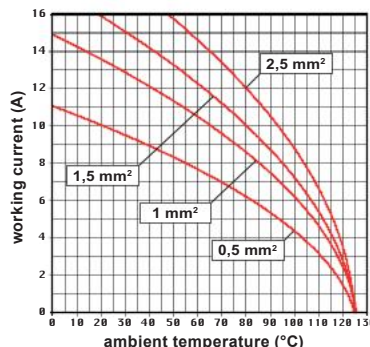
	Pages
Metallic with C-TYPE lever	E.62-69
Metallic with IL-BRID lever	E.96-99, 106
Metallic with JEI®-P lever	E.115-118, 119
Metallic with V-TYPE IP67 lever	E.126, 132-133

Aggressive Environments

Metallic IP68 high protection	E.146-147
Metallic W-TYPE	E.158-159, 164
Metallic E-Xtreme®	E.178-179, 186-187, 196

Specialized Applications

EMC (Electromagnetic Shielding)	E.212-213, 218
Standard applications with Central lever	E.258-259
Light and Sound applications with JEI®-P lever	E.300-301



CTSE 16 inserts max. current load derating diagram

- Can be used only in bulkhead mounting housing;
- can be mated with CNE, CCE, CSH and CSS 16 inserts;
- rear-mounted inserts.

CTSE 24

16 A 500 V

size **104.27**

24 poles + ⊕


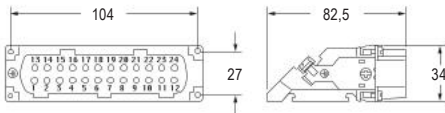

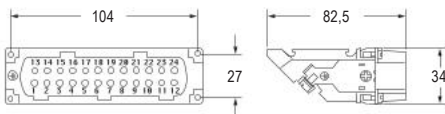

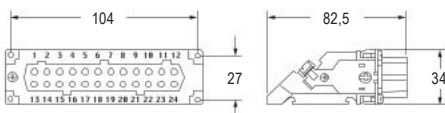

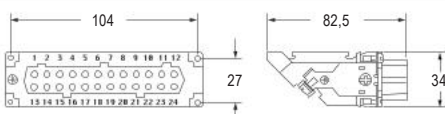
Spring connection

EN 61984 rating	16 A 500 V 6 kV 3
	16 A 400 / 690 V 6 kV 2
Rated voltage (UL / CSA)	600 V
Insulation resistance	≥ 10 GΩ
Contact resistance	≤ 4 mΩ
Ambient temperature limit	-40 °C ... +125 °C
Mechanical life (cycles)	≥ 500

CE UK EAC



ECBT2.E115072 | ECBT8.E115072

Item	Description	Part No.	Dimension
	Male inserts with male contacts Spring terminal connection Mounting side: left	CTSEM 24 L	
	Male inserts with male contacts Spring terminal connection Mounting side: right	CTSEM 24 R	
	Female inserts with female contacts Spring terminal connection Mounting side: left	CTSEF 24 L	
	Female inserts with female contacts Spring terminal connection Mounting side: right	CTSEF 24 R	

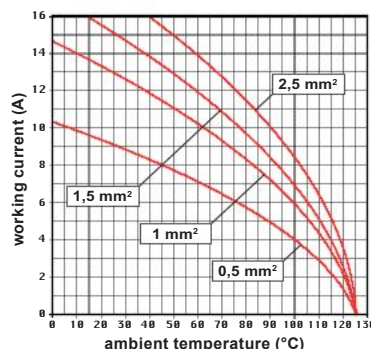
Materials

Insert	polycarbonate (PC)
UL 94 flame rating	V-0
Colour	pebble grey, RAL 7032
Contacts	built-in, copper alloy, silver ● plated

Wiring information

Wires cross sectional area	0,14 mm ² - 2,5 mm ² (AWG 26-14)
Stripping length	9...11 mm

Enclosures size 104.27	Pages
Heavy-Duty Applications	
Metallic with C-TYPE lever	E.70-77
Metallic with IL-BRID lever	E.100-103 107
Metallic with JEI®-P lever	E.117-119
Metallic with V-TYPE IP67 lever	E.127 , 134-135
Aggressive Environments	
Metallic IP68 high protection	E.148-149
Metallic W-TYPE	E.160-161 165
Metallic E-Xtreme®	E.180-181 188-189 197
Specialized Applications	
EMC (Electromagnetic Shielding)	E.214-215 219
Standard applications with Central lever	E.260-261
Light and Sound applications with JEI®-P lever	E.302-303



CTSE 24 inserts max. current load derating diagram

- Can be used only in bulkhead mounting housing;
- can be mated with CNE, CCE, CSH and CSS 24 inserts;
- rear-mounted inserts.

CTSE 16 + CTSE 16 N

16 A 500 V

size **77.62**


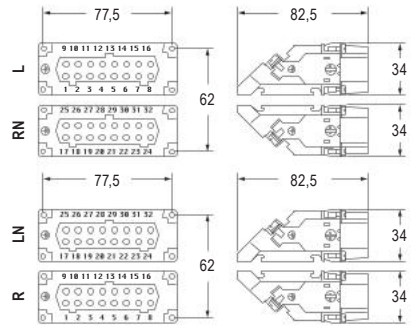

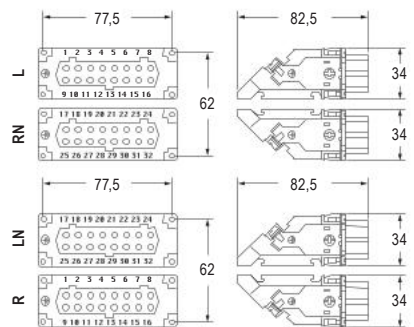
32 poles + ⊕

Spring connection

EN 61984 rating	16 A 500 V 6 kV 3
	16 A 400 / 690 V 6 kV 2
Rated voltage (UL / CSA)	600 V
Insulation resistance	≥ 10 GΩ
Contact resistance	≤ 4 mΩ
Ambient temperature limit	-40 °C ... +125 °C
Mechanical life (cycles)	≥ 500



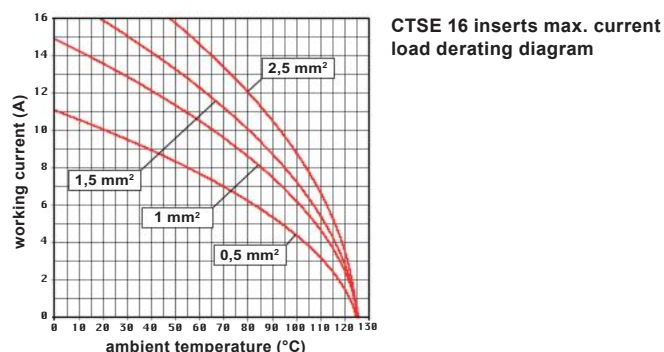
ECBT2.E115072 | ECBT8.E115072

Item	Description	Part No.	Dimension
	Male inserts, No. (1-16) Male inserts, No. (17-32) Spring terminal connection Mounting side: left	CTSEM 16 L CTSEM 16 LN	
	Male inserts, No. (1-16) Male inserts, No. (17-32) Spring terminal connection Mounting side: right	CTSEM 16 R CTSEM 16 RN	
	Female inserts, No. (1-16) Female inserts, No. (17-32) Spring terminal connection Mounting side: left	CTSEF 16 L CTSEF 16 LN	
	Female inserts, No. (1-16) Female inserts, No. (17-32) Spring terminal connection Mounting side: right	CTSEF 16 R CTSEF 16 RN	
	Female inserts, No. (1-16) Female inserts, No. (17-32) Spring terminal connection Mounting side: left	CTSEF 16 L CTSEF 16 LN	
	Female inserts, No. (1-16) Female inserts, No. (17-32) Spring terminal connection Mounting side: right	CTSEF 16 R CTSEF 16 RN	

Materials	
Insert	polycarbonate (PC)
UL 94 flame rating	V-0
Colour	pebble grey, RAL 7032
Contacts	built-in, copper alloy, silver ● plated

Wiring information	
Wires cross sectional area	0,14 mm ² - 2,5 mm ² (AWG 26-14)
Stripping length	9...11 mm

Enclosures size 77.62	Pages
Heavy-Duty Applications	
Metallic with C-TYPE lever	E.78-83
Aggressive Environments	
Metallic W-TYPE with C-TYPE lever	E.166-167
Metallic E-Xtreme® with C-TYPE lever	E.190-191



- Can be used only in bulkhead mounting housing;
- CT screw version on request;
- can be mated with CNE, CCE, CSH and CSS inserts;
- inserts may be fitted from front of enclosure.

CTSE 24 + CTSE 24 N

16 A 500 V


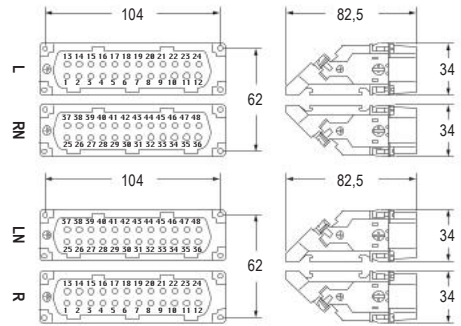

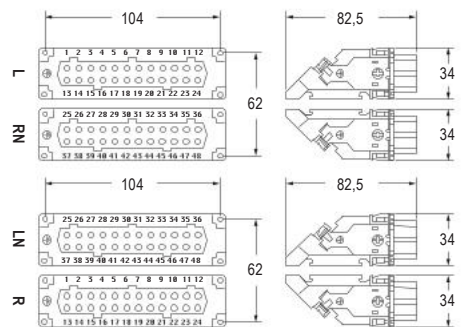
size **104.62****48 poles +** **Spring connection**

EN 61984 rating	16 A 500 V 6 kV 3
	16 A 400 / 690 V 6 kV 2
Rated voltage (UL / CSA)	600 V
Insulation resistance	≥ 10 GΩ
Contact resistance	≤ 4 mΩ
Ambient temperature limit	-40 °C ... +125 °C
Mechanical life (cycles)	≥ 500

CE UK EAC



ECBT2.E115072 | ECBT8.E115072

Item	Description	Part No.	Dimension
	Male inserts, No. (1-24) Male inserts, No. (25-48) Spring terminal connection Mounting side: left	CTSEM 24 L CTSEM 24 LN	
	Male inserts, No. (1-24) Male inserts, No. (25-48) Spring terminal connection Mounting side: right	CTSEM 24 R CTSEM 24 RN	
	Female inserts, No. (1-24) Female inserts, No. (25-48) Spring terminal connection Mounting side: left	CTSEF 24 L CTSEF 24 LN	
	Female inserts, No. (1-24) Female inserts, No. (25-48) Spring terminal connection Mounting side: right	CTSEF 24 R CTSEF 24 RN	
	Female inserts, No. (1-24) Female inserts, No. (25-48) Spring terminal connection Mounting side: left	CTSEF 24 L CTSEF 24 LN	
	Female inserts, No. (1-24) Female inserts, No. (25-48) Spring terminal connection Mounting side: right	CTSEF 24 R CTSEF 24 RN	

Materials

Insert	polycarbonate (PC)
UL 94 flame rating	V-0
Colour	pebble grey, RAL 7032
Contacts	built-in, copper alloy, silver ● plated

Wiring information

Wires cross sectional area	0,14 mm ² - 2,5 mm ² (AWG 26-14)
Stripping length	9...11 mm

Enclosures size 104.62Pages **Heavy-Duty Applications**

Metallic with C-TYPE lever

[E.84-85](#)**Aggressive Environments**

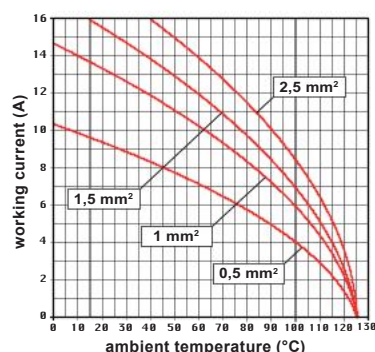
Metallic W-TYPE with C-TYPE lever

[E.168-169](#)

Metallic E-Xtreme® with C-TYPE lever

[E.192-193](#)

- Can be used only in bulkhead mounting housing;
- CT screw version on request;
- can be mated with CNE, CCE, CSH and CSS inserts;
- inserts may be fitted from front of enclosure.

**CTSE 24 inserts max. current load derating diagram**

CT / CTS series. Inserts with incorporated terminal block for multipole connectors (10 A max versions)



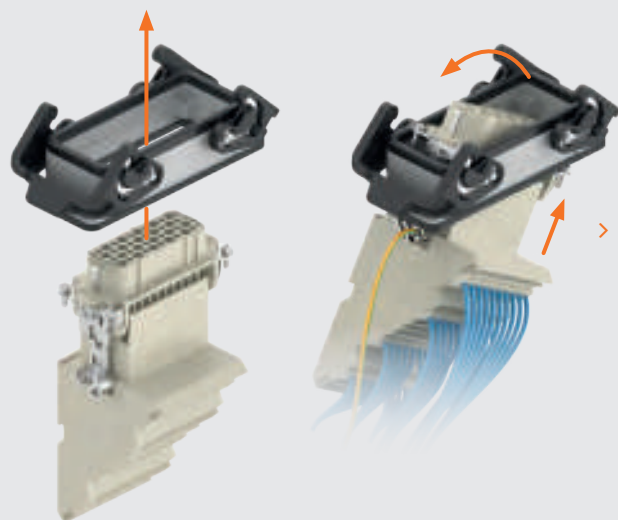
CT-CTS series overview

CT series for multipole connectors (with incorporated 45° terminal block) are recommended for greater cost-saving and safety for use on machines and command and control panels.

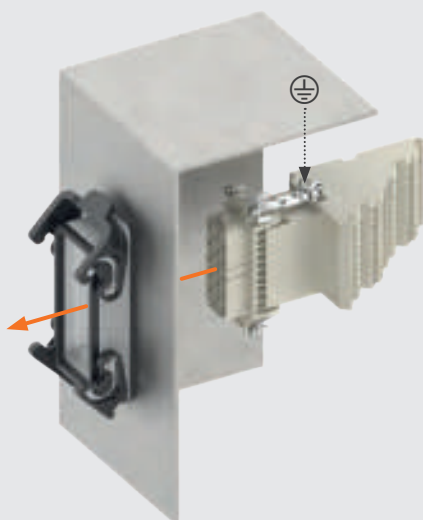
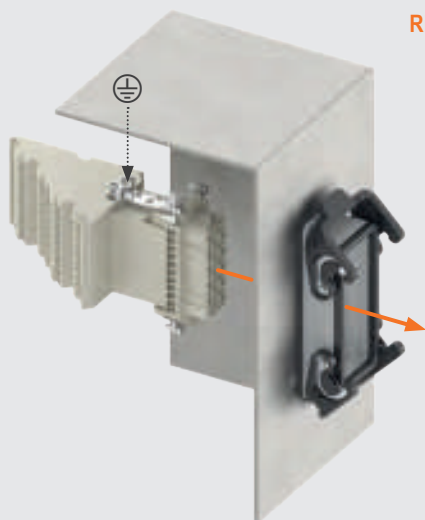
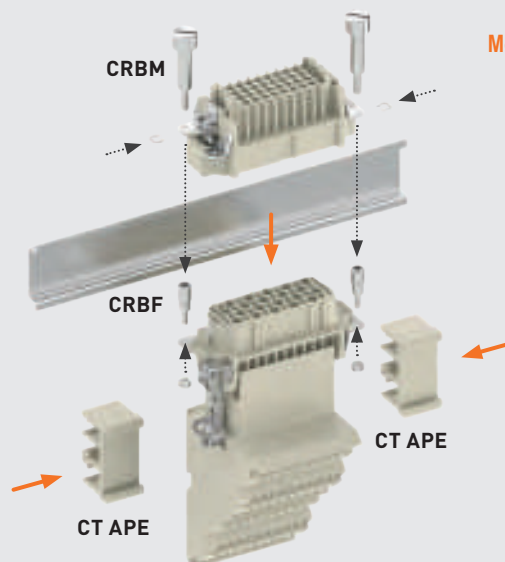
- > Must be used for control panel mounting, bulkhead housings.
- > **CT series inserts** (10 A max versions) are supplied in the plug or socket versions and must be mounted with insertion from the rear of the enclosure (Figures 1 and 2), as the space occupied by the terminal block does not allow for the passage of the insert and insertion from the front of the enclosure.
- > As an alternative to the traditional terminal blocks, the inserts can be mounted inside the control panels on DIN EN 60715 rails (Figure 5) using suitable accessories providing the added advantage of easy sectioning.
- > The special structure of CT inserts provides all the conductor connections on the same side, achieving easier wiring and a complete view of the work area. The 45° terminal block has also slots for housing the identification wire markers of each contact.
- > Wire markers of different manufacturers may be used such as: Cabur, Grafoplast, Modernotecnica, Phoenix Contact, Siemens, Wago, Weidmüller.
- > **CT series** is available in the versions “left-hand” and “right-hand” for mounting on the left (Figure 3) or on the right (Figure 4) of the control panel walls. This characteristic is determined by the position of contact “1” and the protective earth terminal in the upper part of the insert terminal block for both left and right mounting.
- > The installation of inserts on DIN rails (Figure 5) inside the control panels is usually made to ease the wiring in sectionable parts. In this case the degree of protection for coupled connectors is IP20 (in accordance with EN 60529). This type of mounting requires supports (**CT APE**) suitable for mounting on DIN EN 60715 rail, to be provided to the inserts.
- > In addition, **CRBF** (female) and **CRBM** (male) coupling screws instead of normal screws are recommended for fixing the inserts to the enclosures (Figure 5) in order to guarantee a stable and safe coupling between the CT and CTS inserts installed on the DIN rails and corresponding mating CD inserts.

FOCUS

Inserts with incorporated 45° terminal block

Figure 1 and 2
Rear mounting

- > The insert must be mounted into the bulkhead housing from below, with or without wired conductors.

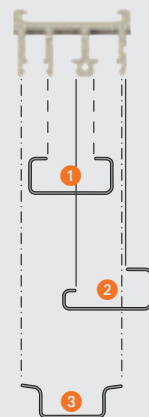
Figure 3
Left mountingFigure 4
Right mountingFigure 5
Mounting on
DIN rail**CT APE**

Possibility of coupling to DIN EN 60715 rail (for a greater stability of the CT inserts of 40 and 64 poles we recommend using the two CT APE supports)

- 1 EN 60715 C 30
- 2 EN 60715 G 32
- 3 EN 60715 TH 35-7,5 and TH 35-15

Accessories for CT inserts

- > support for mounting on DIN rail **CT APE**
- > inserts coupling screws **CRBM** and **CRBF**
- > cable-clamping plates **CRAD** and **CRAS**



CT 40

10 A 250 V


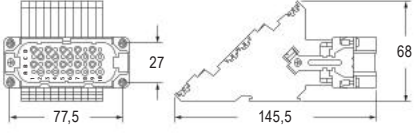

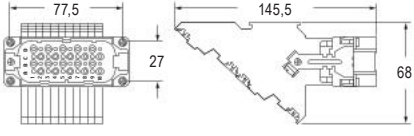

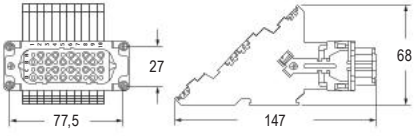

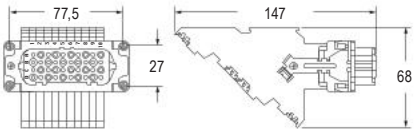
size **77.27**
40 poles + ⊕

Screw connection

EN 61984 rating	10 A 250 V 4 kV 3
	10 A 230 / 400 V 4 kV 2
Rated voltage (UL / CSA)	600 V
Insulation resistance	≥ 10 GΩ
Contact resistance	≤ 4 mΩ
Ambient temperature limit	-40 °C ... +125 °C
Mechanical life (cycles)	≥ 500



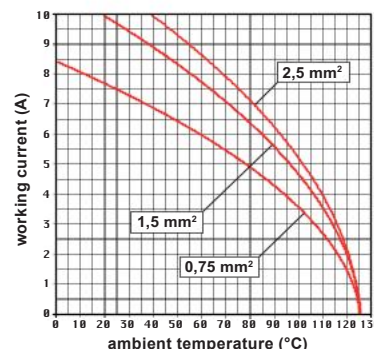
ECBT2.E115072 | ECBT8.E115072

Item	Description	Part No.	Dimension
	Male inserts with male contacts Screw terminal connection Mounting side: left	CTM 40 L	
	Male inserts with male contacts Screw terminal connection Mounting side: right	CTM 40 R	
	Female inserts with female contacts Screw terminal connection Mounting side: left	CTF 40 L	
	Female inserts with female contacts Screw terminal connection Mounting side: right	CTF 40 R	

Materials	
Insert	polycarbonate (PC)
UL 94 flame rating	V-0
Colour	pebble grey, RAL 7032
Contacts	built-in, copper alloy, silver ● plated

Wiring information	
Wires cross sectional area	0,75 mm ² - 2,5 mm ² (AWG 18-14)
unprepared	12 mm
Stripping length	12 mm
Terminal screw torque	0,4 Nm (3.54 lb.in)

Enclosures size 77.27	Pages
Heavy-Duty Applications	
Metallic with C-TYPE lever	E.62-69
Metallic with IL-BRID lever	E.96-99 , 106
Metallic with JEI®-P lever	E.115-116 , 119
Metallic with V-TYPE IP67 lever	E.126 , 132-133
Aggressive Environments	
Metallic IP68 high protection	E.146-147
Metallic W-TYPE	E.158-159 , 164
Metallic E-Xtreme®	E.178-179 , 186-187 , 196
Specialized Applications	
EMC (Electromagnetic Shielding)	E.212-213 , 218
Standard applications with Central lever	E.258-259
Light and Sound applications with JEI®-P lever	E.300-301



CT 40 inserts max. current load derating diagram

- Can be used only in bulkhead mounting housing;
- can be mated with **CD 40** inserts;
- rear-mounted inserts.


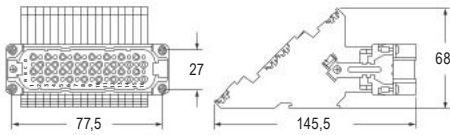

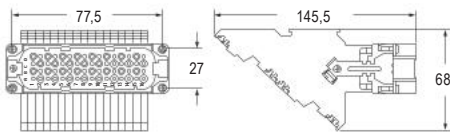

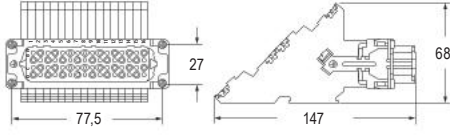

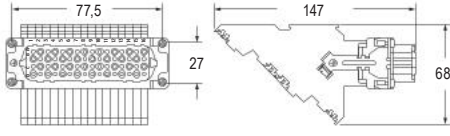
CT 64**10 A 250 V**size **104.27****64 poles + ⊕****Screw connection**

EN 61984 rating	10 A 250 V 4 kV 3
	10 A 230 / 400 V 4 kV 2
Rated voltage (UL / CSA)	600 V
Insulation resistance	≥ 10 GΩ
Contact resistance	≤ 4 mΩ
Ambient temperature limit	-40 °C ... +125 °C
Mechanical life (cycles)	≥ 500

CE UK EAC



ECBT2.E115072 | ECBT8.E115072

Item	Description	Part No.	Dimension
	Male inserts with male contacts Screw terminal connection Mounting side: left	CTM 64 L	
	Male inserts with male contacts Screw terminal connection Mounting side: right	CTM 64 R	
	Female inserts with female contacts Screw terminal connection Mounting side: left	CTF 64 L	
	Female inserts with female contacts Screw terminal connection Mounting side: right	CTF 64 R	

Materials

Insert	polycarbonate (PC)
UL 94 flame rating	V-0
Colour	pebble grey, RAL 7032
Contacts	built-in, copper alloy, silver ● plated

Wiring information

Wires cross sectional area	0,75 mm ² - 2,5 mm ² (AWG 18-14)
unprepared	12 mm
Stripping length	12 mm
Terminal screw torque	0,4 Nm (3.54 lb.in)

Enclosures size 104.27**Pages****Heavy-Duty Applications**

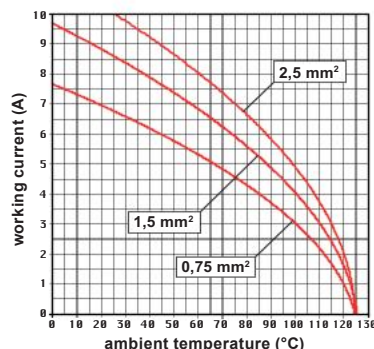
Metallic with C-TYPE lever	E.70-77
Metallic with IL-BRID lever	E.100-103 107
Metallic with JEI®-P lever	E.117-119
Metallic with V-TYPE IP67 lever	E.127, 134-135

Aggressive Environments

Metallic IP68 high protection	E.148-149
Metallic W-TYPE	E.160-161 165
Metallic E-Xtreme®	E.180-181 188-189 197

Specialized Applications

EMC (Electromagnetic Shielding)	E.214-215 219
Standard applications with Central lever	E.260-261
Light and Sound applications with JEI®-P lever	E.302-303

**CT 64 inserts max. current load derating diagram**

- Can be used only in bulkhead mounting housing;
- can be mated with **CD 64** inserts;
- rear-mounted inserts.

CTS 40

10 A 250 V


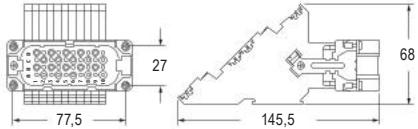

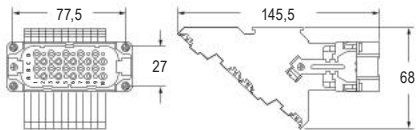

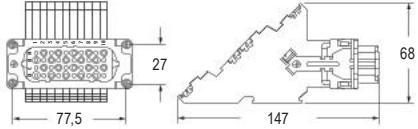

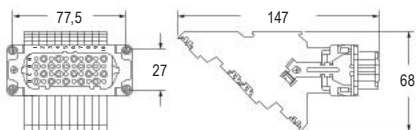
size **77.27**
40 poles + ⊕

Spring connection

EN 61984 rating	10 A 250 V 4 kV 3
	10 A 230 / 400 V 4 kV 2
Rated voltage (UL / CSA)	600 V
Insulation resistance	≥ 10 GΩ
Contact resistance	≤ 4 mΩ
Ambient temperature limit	-40 °C ... +125 °C
Mechanical life (cycles)	≥ 500



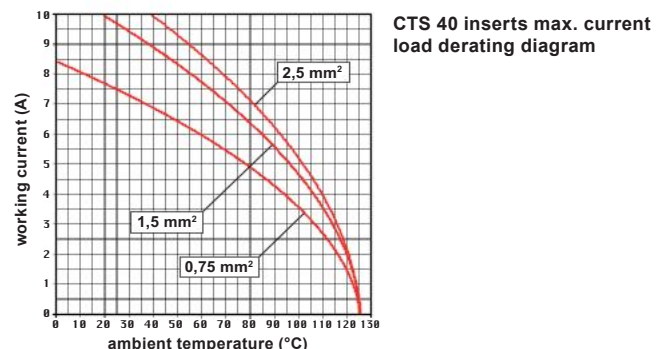
ECBT2.E115072 | ECBT8.E115072

Item	Description	Part No.	Dimension
	Male inserts with male contacts Spring terminal connection Mounting side: left	CTSM 40 L	
	Male inserts with male contacts Spring terminal connection Mounting side: right	CTSM 40 R	
	Female inserts with female contacts Spring terminal connection Mounting side: left	CTSF 40 L	
	Female inserts with female contacts Spring terminal connection Mounting side: right	CTSF 40 R	

Materials	
Insert	polycarbonate (PC)
UL 94 flame rating	V-0
Colour	pebble grey, RAL 7032
Contacts	built-in, copper alloy, silver ● plated

Wiring information	
Wires cross sectional area	
- unprepared	0,14 mm ² - 2,5 mm ² (AWG 26-14)
- prepared	0,14 mm ² - 1 mm ² (AWG 26-18)
Stripping length	9...11 mm

Enclosures size 77.27	Pages
Heavy-Duty Applications	
Metallic with C-TYPE lever	E.62-69
Metallic with IL-BRID lever	E.96-99, 106
Metallic with JEI®-P lever	E.115-116, 119
Metallic with V-TYPE IP67 lever	E.126, 132-133
Aggressive Environments	
Metallic IP68 high protection	E.146-147
Metallic W-TYPE	E.158-159, 164
Metallic E-Xtreme®	E.178-179, 186-187, 196
Specialized Applications	
EMC (Electromagnetic Shielding)	E.212-213, 218
Standard applications with Central lever	E.258-259
Light and Sound applications with JEI®-P lever	E.300-301



- Can be used only in bulkhead mounting housing;
- can be mated with CD 40 inserts;
- rear-mounted inserts.

CTS 64

10 A 250 V


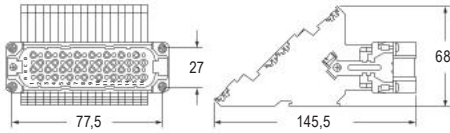

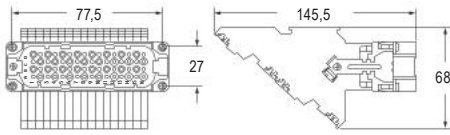

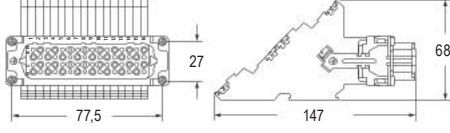

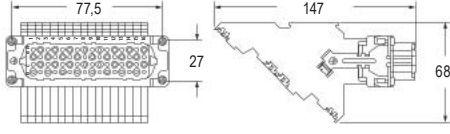
size **104.27****64 poles + ⊕****Spring connection**

EN 61984 rating	10 A 250 V 4 kV 3
	10 A 230 / 400 V 4 kV 2
Rated voltage (UL / CSA)	600 V
Insulation resistance	≥ 10 GΩ
Contact resistance	≤ 4 mΩ
Ambient temperature limit	-40 °C ... +125 °C
Mechanical life (cycles)	≥ 500

CE UK EAC



ECBT2.E115072 | ECBT8.E115072

Item	Description	Part No.	Dimension
	Male inserts with male contacts Spring terminal connection Mounting side: left	CTSM 64 L	
	Male inserts with male contacts Spring terminal connection Mounting side: right	CTSM 64 R	
	Female inserts with female contacts Spring terminal connection Mounting side: left	CTSF 64 L	
	Female inserts with female contacts Spring terminal connection Mounting side: right	CTSF 64 R	

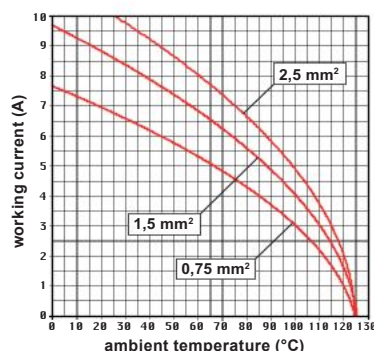
Materials

Insert	polycarbonate (PC)
UL 94 flame rating	V-0
Colour	pebble grey, RAL 7032
Contacts	built-in, copper alloy, silver ● plated

Wiring information

Wires cross sectional area	
- unprepared	0,14 mm ² - 2,5 mm ² (AWG 26-14)
- prepared	0,14 mm ² - 1 mm ² (AWG 26-18)
Stripping length	9...11 mm

Enclosures size 104.27	Pages
Heavy-Duty Applications	
Metallic with C-TYPE lever	E.70-77
Metallic with IL-BRID lever	E.100-103 107
Metallic with JEI®-P lever	E.117-119
Metallic with V-TYPE IP67 lever	E.127 134-135
Aggressive Environments	
Metallic IP68 high protection	E.148-149
Metallic W-TYPE	E.160-161 165
Metallic E-Xtreme®	E.180-181 188-189 197
Specialized Applications	
EMC (Electromagnetic Shielding)	E.214-215 219
Standard applications with Central lever	E.260-261
Light and Sound applications with JEI®-P lever	E.302-303



CTS 64 inserts max. current load derating diagram

- Can be used only in bulkhead mounting housing;
- can be mated with **CD 64** inserts;
- rear-mounted inserts.

CMCE and CMSH series



CMCE and CMSH series overview

The **CMCE** and **CMSH** connector series features 16 A current-rated inserts designed for high-voltage applications up to 830 V.

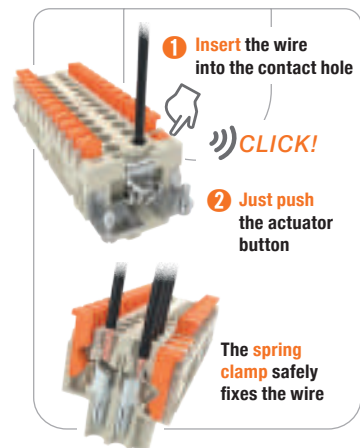
The inserts are available in two connection technologies: crimp for the CMCE inserts, using CC series 16 A contacts, and tool-less SQUICH® for the CMSH inserts, benefiting from a quick, simple and error-free installation.

KEY FEATURES

CMCE and CMSH inserts for high voltage are compatible with all relevant ILME enclosure series, thermoplastic and metallic, without limitation due to the required insulating distances (see "Dimensioning of clearances and creepage distances" on page J.10).

TECHNOLOGY
AT A GLANCE

 **SQUICH®**





Watch our clip

Single inserts versions

- > **CMCE 03** (3P + ⊕)
16 A 830 V 8 kV 3
size 57.27
- > **CMCE 06** (6P + ⊕)
116 A 830 V 8 kV 3
size 77.27
- > **CMCE 10** (10P + ⊕)
16 A 830 V 8 kV 3
size 104.27
- > **CMSH 03** (3P + ⊕)
16 A 830 V 8 kV 3
size 57.27
- > **CMSH 06** (6P + ⊕)
16 A 830 V 8 kV 3
size 77.27
- > **CMSH 10** (10P + ⊕)
16 A 830 V 8 kV 3
size 104.27



Double inserts versions, side by side

- > **CMCE 06 + CMCE 06 N** (12P + ⊕)
16 A 830 V 8 kV 3 – size 77.62
- > **CMSH 06 + CMSH 06 N** (12P + ⊕)
16 A 830 V 8 kV 3 – size 77.62
- > **CMCE 10 + CMCE 10 N** (20P + ⊕)
16 A 830 V 8 kV 3 – size 104.62
- > **CMSH 10 + CMSH 10 N** (20P + ⊕)
16 A 830 V 8 kV 3 – size 104.62

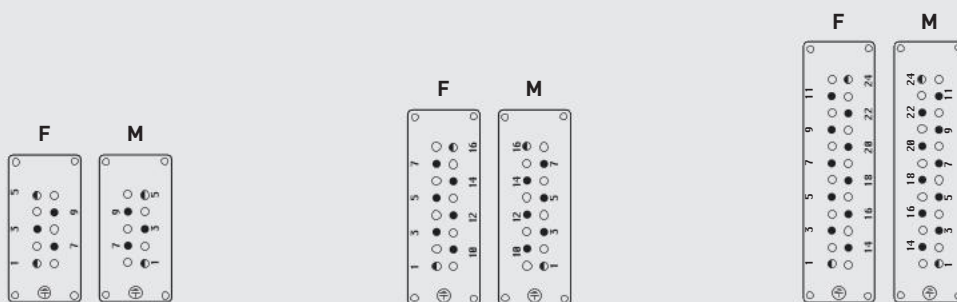


FOCUS

Auxiliary contacts for high voltage inserts

The design includes the presence of two auxiliary contacts for each inserts, by means of anticipated crimp contacts series CC..AN for the CMCE crimp versions, and built-in anticipated contacts for the CMSH series.

In order to avoid incorrect mating with similar inserts with lower voltage the inserts are permanently coded with distinctive red plugs in the unused terminal cavities.



contacts side - front view

- without contact
- working contact
- auxiliary contact

M = male insert
F = female insert

CMCE 03

16 A 830 V


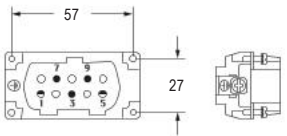
size **57.27**
3 + 2 aux. poles + ⊕


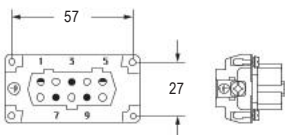
Crimp connection


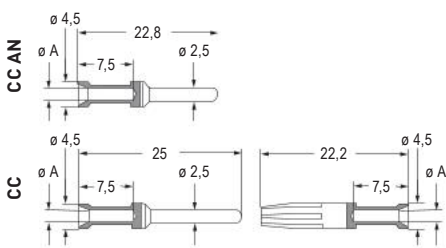


EN 61984 rating	16 A 830 V 8 kV 3
	16 A 1000 V 8 kV 2
auxiliary contacts:	16 A 720 / 1250 V 8 kV 2
	16 A 500 V 6 kV 3
Rated voltage (UL / CSA)	600 V
Insulation resistance	≥ 10 GΩ
Contact resistance	≤ 1 mΩ
Ambient temperature limit	-40 °C ... +125 °C
Mechanical life (cycles)	≥ 500



ILME US ECBT2.E115072 | ECBT8.E115072

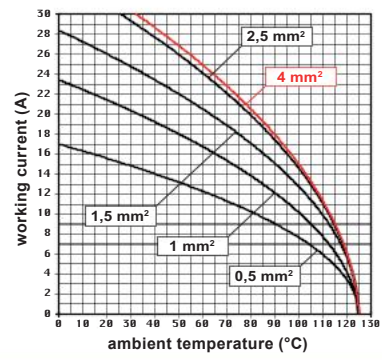
Item	Description	Part No.	Dimension
	Male inserts for male contacts Without contacts (to be ordered separately) ● Auxiliary contacts positions: poles 1 and 5	CMCEM 03	

	Female inserts for female contacts Without contacts (to be ordered separately) ● Auxiliary contacts positions: poles 1 and 5	CMCEF 03	
---	--	--------------------------	---

	16 A advanced opening contacts	Male	Female																												
	section (mm ²) section (AWG) 0,5 20 0,75 18 1 18 1,5 16 2,5 14	CC 0.5 AN CC 0.7 AN CC 1.0 AN CC 1.5 AN CC 2.5 AN																													
	16 A crimp contacts section (mm ²) section (AWG) 0,14-0,37 26-22 0,5 20 0,75 18 1 18 1,5 16 2,5 14 3 12 4 12	CCMA 0.3 CCMA 0.5 CCMA 0.7 CCMA 1.0 CCMA 1.5 CCMA 2.5 CCMA 3.0 CCMA 4.0	CCFA 0.3 CCFA 0.5 CCFA 0.7 CCFA 1.0 CCFA 1.5 CCFA 2.5 CCFA 3.0 CCFA 4.0	Wiring information, CC contacts <table border="1"> <thead> <tr> <th>conductor section (mm²)</th> <th>conductor slot ø A (mm)</th> <th>stripping length (mm)</th> </tr> </thead> <tbody> <tr><td>0,14-0,37</td><td>0,9</td><td>7,5</td></tr> <tr><td>0,5</td><td>1,1</td><td>7,5</td></tr> <tr><td>0,75</td><td>1,3</td><td>7,5</td></tr> <tr><td>1,0</td><td>1,45</td><td>7,5</td></tr> <tr><td>1,5</td><td>1,8</td><td>7,5</td></tr> <tr><td>2,5</td><td>2,2</td><td>7,5</td></tr> <tr><td>3,0</td><td>2,55</td><td>7,5</td></tr> <tr><td>4,0</td><td>2,85</td><td>7,5</td></tr> </tbody> </table> Wire diameter: up to 4,7 mm. For basic or high thickness gold plating, please refer to page E.13 It is recommended to use the crimping tools and removal tools homologated by ILME (please see page E.23)	conductor section (mm ²)	conductor slot ø A (mm)	stripping length (mm)	0,14-0,37	0,9	7,5	0,5	1,1	7,5	0,75	1,3	7,5	1,0	1,45	7,5	1,5	1,8	7,5	2,5	2,2	7,5	3,0	2,55	7,5	4,0	2,85	7,5
conductor section (mm ²)	conductor slot ø A (mm)	stripping length (mm)																													
0,14-0,37	0,9	7,5																													
0,5	1,1	7,5																													
0,75	1,3	7,5																													
1,0	1,45	7,5																													
1,5	1,8	7,5																													
2,5	2,2	7,5																													
3,0	2,55	7,5																													
4,0	2,85	7,5																													
	0,14-0,37 26-22 0,5 20 0,75 18 1 18 1,5 16 2,5 14 3 12 4 12	CCMD 0.3 CCMD 0.5 CCMD 0.7 CCMD 1.0 CCMD 1.5 CCMD 2.5 CCMD 3.0 CCMD 4.0	CCFD 0.3 CCFD 0.5 CCFD 0.7 CCFD 1.0 CCFD 1.5 CCFD 2.5 CCFD 3.0 CCFD 4.0																												

Materials	
Insert	polycarbonate (PC)
UL 94 flame rating	V-0
Colour	pebble grey, RAL 7032
Contacts	copper alloy, silver ● and gold ● plated

Enclosures size 57.27	Pages
Heavy-Duty Applications	
Metallic with C-TYPE lever	E.54-61
Metallic with IL-BRID lever	E.92-95 , 105
Metallic with JEI®-P lever	E.113-114 , 119
Metallic with V-TYPE IP67 lever	E.125 , 130-131
Thermoplastic T-TYPE	E.228-229 , 234-235
Aggressive Environments	
Metallic IP68 high protection	E.144-145
Metallic W-TYPE	E.156-157 , 163
Metallic E-Xtreme®	E.176-177 , 184-185 , 195
Thermoplastic T-TYPE/W	E.228-229 , 234-235
Specialized Applications	
EMC (Electromagnetic Shielding)	E.210-211 , 217
Hygienic series for food and beverage	E.243 , 248
Standard applications with Central lever	E.256-257
BIG Enclosures for multiple cable entries	E.269 , 274-275
COB system for switch cabinet	E.286-289
Light and Sound applications with JEI®-P lever	E.298-299



CMCE 03 inserts max. current load derating diagram

CMCE 06

16 A 830 V

size **77.27**

6 + 2 aux. poles + ⊕

Crimp connection

EN 61984 rating	16 A 830 V 8 kV 3
	16 A 1000 V 8 kV 2
	16 A 720 / 1250 V 8 kV 2
auxiliary contacts:	16 A 500 V 6 kV 3
Rated voltage (UL / CSA)	600 V
Insulation resistance	≥ 10 GΩ
Contact resistance	≤ 1 mΩ
Ambient temperature limit	-40 °C ... +125 °C
Mechanical life (cycles)	≥ 500



ILME US ECBT2.E115072 | ECBT8.E115072

Item	Description	Part No.	Dimension
	Male inserts for male contacts Without contacts (to be ordered separately) ● Auxiliary contacts positions: poles 1 and 16	CMCEM 06	

	Female inserts for female contacts Without contacts (to be ordered separately) ● Auxiliary contacts positions: poles 1 and 16	CMCEF 06	
--	---	--------------------------	--

	16 A advanced opening contacts	Male	Female	
	section (mm ²) section (AWG)			
	0,5 20	CC 0.5 AN		
	0,75 18	CC 0.7 AN		
	1 18	CC 1.0 AN		
	1,5 16	CC 1.5 AN		
	2,5 14	CC 2.5 AN		
	section (mm ²) section (AWG)			
	0,14-0,37 26-22	CCMA 0.3	CCFA 0.3	
	0,5 20	CCMA 0.5	CCFA 0.5	
	0,75 18	CCMA 0.7	CCFA 0.7	
	1 18	CCMA 1.0	CCFA 1.0	
	1,5 16	CCMA 1.5	CCFA 1.5	
	2,5 14	CCMA 2.5	CCFA 2.5	
	3 12	CCMA 3.0	CCFA 3.0	
	4 12	CCMA 4.0	CCFA 4.0	
	0,14-0,37 26-22	CCMD 0.3	CCFD 0.3	
	0,5 20	CCMD 0.5	CCFD 0.5	
	0,75 18	CCMD 0.7	CCFD 0.7	
	1 18	CCMD 1.0	CCFD 1.0	
	1,5 16	CCMD 1.5	CCFD 1.5	
	2,5 14	CCMD 2.5	CCFD 2.5	
	3 12	CCMD 3.0	CCFD 3.0	
	4 12	CCMD 4.0	CCFD 4.0	

Wiring information, CC contacts

conductor section (mm ²)	conductor slot ø A (mm)	stripping length (mm)
0,14-0,37	0,9	7,5
0,5	1,1	7,5
0,75	1,3	7,5
1,0	1,45	7,5
1,5	1,8	7,5
2,5	2,2	7,5
3,0	2,55	7,5
4,0	2,85	7,5

Wire diameter: up to 4,7 mm.

For basic or high thickness gold plating, please refer to page [E.13](#).

It is recommended to use the crimping tools and removal tools homologated by ILME (please see page [E.23](#)).

Materials

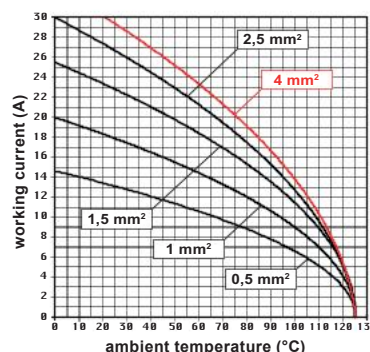
Insert	polycarbonate (PC)
UL 94 flame rating	V-0
Colour	pebble grey, RAL 7032
Contacts	copper alloy, silver ● and gold ● plated

CR CPQ
Coding pins
Page [E.3](#)

Enclosures size 77.27

Pages

Heavy-Duty Applications	Pages
Metallic with C-TYPE lever	E.62-69
Metallic with IL-BRID lever	E.96-99 , I06
Metallic with JEI®-P lever	E.115-116 , I19
Metallic with V-TYPE IP67 lever	E.126 , I32-133
Thermoplastic T-TYPE	E.230-231 , I34-235
Aggressive Environments	
Metallic IP68 high protection	E.146-147
Metallic W-TYPE	E.158-159 , I64
Metallic E-Xtreme®	E.178-179 , I86-187 , I96
Thermoplastic T-TYPE/W	E.230-231 , I34-235
Specialized Applications	
EMC (Electromagnetic Shielding)	E.212-213 , I18
Hygienic series for food and beverage	E.246 , I248
Standard applications with Central lever	E.258-259
BIG Enclosures for multiple cable entries	E.270 , I276-277
COB system for switch cabinet	E.286-289
Light and Sound applications with JEI®-P lever	E.300-301



CMCE 06 inserts max. current load derating diagram

CMCE 10

16 A 830 V


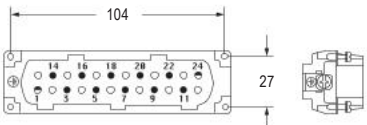
size **104.27**
10 + 2 aux. poles + ⊕

Crimp connection


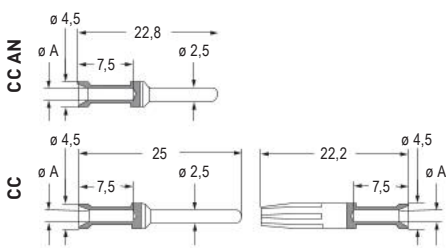


EN 61984 rating	16 A 830 V 8 kV 3
	16 A 1000 V 8 kV 2
	16 A 720 / 1250 V 8 kV 2
	auxiliary contacts: 16 A 500 V 6 kV 3
Rated voltage (UL / CSA)	600 V
Insulation resistance	≥ 10 GΩ
Contact resistance	≤ 1 mΩ
Ambient temperature limit	-40 °C ... +125 °C
Mechanical life (cycles)	≥ 500



CBUS ECBT2.E115072 | ECBT8.E115072

Item	Description	Part No.	Dimension
	Male inserts for male contacts Without contacts (to be ordered separately) ● Auxiliary contacts positions: poles 1 and 24	CMCEM 10	

	Female inserts for female contacts Without contacts (to be ordered separately) ● Auxiliary contacts positions: poles 1 and 24	CMCEF 10	
---	---	--------------------------	---

	16 A advanced opening contacts	Male	Female		
	section (mm ²)				
	section (AWG)				
	0,5	20	CC 0.5 AN		
	0,75	18	CC 0.7 AN		
	1	18	CC 1.0 AN		
	16 A crimp contacts			Wiring information, CC contacts	
	section (mm ²)	section (AWG)			
	0,14-0,37	26-22	CCMA 0.3		CCFA 0.3
	0,5	20	CCMA 0.5		CCFA 0.5
	0,75	18	CCMA 0.7		CCFA 0.7
	1	18	CCMA 1.0		CCFA 1.0
	1,5	16	CCMA 1.5		CCFA 1.5
	2,5	14	CCMA 2.5		CCFA 2.5
	3	12	CCMA 3.0		CCFA 3.0
	4	12	CCMA 4.0		CCFA 4.0
	0,14-0,37	26-22	CCMD 0.3	CCFD 0.3	
	0,5	20	CCMD 0.5	CCFD 0.5	
	0,75	18	CCMD 0.7	CCFD 0.7	
	1	18	CCMD 1.0	CCFD 1.0	
	1,5	16	CCMD 1.5	CCFD 1.5	
	2,5	14	CCMD 2.5	CCFD 2.5	
	3	12	CCMD 3.0	CCFD 3.0	
	4	12	CCMD 4.0	CCFD 4.0	

Wiring information, CC contacts

conductor section (mm ²)	conductor slot ø A (mm)	stripping length (mm)
0,14-0,37	0,9	7,5
0,5	1,1	7,5
0,75	1,3	7,5
1,0	1,45	7,5
1,5	1,8	7,5
2,5	2,2	7,5
3,0	2,55	7,5
4,0	2,85	7,5


Wire diameter: up to 4,7 mm.

For basic or high thickness gold plating, please refer to page [E.13](#)

It is recommended to use the crimping tools and removal tools homologated by ILME (please see page [E.23](#))

Materials

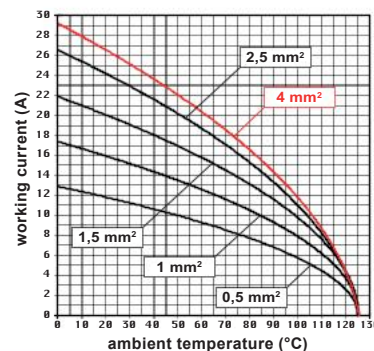
Insert	polycarbonate (PC)
UL 94 flame rating	V-0
Colour	pebble grey, RAL 7032
Contacts	copper alloy, silver ● and gold ● plated



CR CPQ
Coding pins
Page [E.3](#)

Enclosures size 104.27

Heavy-Duty Applications	Pages
Metallic with C-TYPE lever	E.70-77
Metallic with IL-BRID lever	E.100-103 , 107
Metallic with JEI®-P lever	E.117-119
Metallic with V-TYPE IP67 lever	E.127 , 134-135
Thermoplastic T-TYPE	E.232-235
Aggressive Environments	
Metallic IP68 high protection	E.148-149
Metallic W-TYPE	E.160-161 , 165
Metallic E-Xtreme®	E.180-181 , 188-189 , 197
Thermoplastic T-TYPE/W	E.232-235
Specialized Applications	
EMC (Electromagnetic Shielding)	E.214-215 , 219
Hygienic series for food and beverage	E.247-248
Standard applications with Central lever	E.260-261
BIG Enclosures for multiple cable entries	E.271 , 278-279
COB system for switch cabinet	E.286-289
Light and Sound applications with JEI®-P lever	E.302-303



CMCE 10 inserts max. current load derating diagram

CMCE 06 + CMCE 06 N

16 A 830 V

size 77.62

12 + 4 aux. poles +

Crimp connection

EN 61984 rating	16 A 830 V 8 kV 3
	16 A 1000 V 8 kV 2
	16 A 720 / 1250 V 8 kV 2
	auxiliary contacts: 16 A 500 V 6 kV 3
Rated voltage (UL / CSA)	600 V
Insulation resistance	≥ 10 GΩ
Contact resistance	≤ 1 mΩ
Ambient temperature limit	-40 °C ... +125 °C
Mechanical life (cycles)	≥ 500

ECBT2.E115072 | ECBT8.E115072

Item	Description	Part No.	Dimension																											
	Male inserts, No. (1-16) Male inserts, No. (17-32) Without contacts (to be ordered separately) ● Auxiliary contacts positions: poles 1, 16 and 17, 32	CMCEM 06 CMCEM 06 N																												
	Female inserts, No. (1-16) Female inserts, No. (17-32) Without contacts (to be ordered separately) ● Auxiliary contacts positions: poles 1, 16 and 17, 32	CMCEF 06 CMCEF 06 N																												
	16 A advanced opening contacts section (mm ²) section (AWG) 0,5 20 0,75 18 1 18 1,5 16 2,5 14	Male CC 0.5 AN CC 0.7 AN CC 1.0 AN CC 1.5 AN CC 2.5 AN	Female 																											
	16 A crimp contacts section (mm ²) section (AWG) 0,14-0,37 26-22 0,5 20 0,75 18 1 18 1,5 16 2,5 14 3 12 4 12	Male CCMA 0.3 CCMA 0.5 CCMA 0.7 CCMA 1.0 CCMA 1.5 CCMA 2.5 CCMA 3.0 CCMA 4.0	Female CCFA 0.3 CCFA 0.5 CCFA 0.7 CCFA 1.0 CCFA 1.5 CCFA 2.5 CCFA 3.0 CCFA 4.0																											
	0,14-0,37 26-22 0,5 20 0,75 18 1 18 1,5 16 2,5 14 3 12 4 12	Male CCMD 0.3 CCMD 0.5 CCMD 0.7 CCMD 1.0 CCMD 1.5 CCMD 2.5 CCMD 3.0 CCMD 4.0	Female CCFD 0.3 CCFD 0.5 CCFD 0.7 CCFD 1.0 CCFD 1.5 CCFD 2.5 CCFD 3.0 CCFD 4.0																											
Wiring information, CC contacts <table border="1"> <thead> <tr> <th>conductor section (mm²)</th> <th>conductor slot ø A (mm)</th> <th>stripping length (mm)</th> </tr> </thead> <tbody> <tr><td>0,14-0,37</td><td>0,9</td><td>7,5</td></tr> <tr><td>0,5</td><td>1,1</td><td>7,5</td></tr> <tr><td>0,75</td><td>1,3</td><td>7,5</td></tr> <tr><td>1,0</td><td>1,45</td><td>7,5</td></tr> <tr><td>1,5</td><td>1,8</td><td>7,5</td></tr> <tr><td>2,5</td><td>2,2</td><td>7,5</td></tr> <tr><td>3,0</td><td>2,55</td><td>7,5</td></tr> <tr><td>4,0</td><td>2,85</td><td>7,5</td></tr> </tbody> </table>				conductor section (mm ²)	conductor slot ø A (mm)	stripping length (mm)	0,14-0,37	0,9	7,5	0,5	1,1	7,5	0,75	1,3	7,5	1,0	1,45	7,5	1,5	1,8	7,5	2,5	2,2	7,5	3,0	2,55	7,5	4,0	2,85	7,5
conductor section (mm ²)	conductor slot ø A (mm)	stripping length (mm)																												
0,14-0,37	0,9	7,5																												
0,5	1,1	7,5																												
0,75	1,3	7,5																												
1,0	1,45	7,5																												
1,5	1,8	7,5																												
2,5	2,2	7,5																												
3,0	2,55	7,5																												
4,0	2,85	7,5																												
Wire diameter: up to 4,7 mm. For basic or high thickness gold plating, please refer to page E.13 . It is recommended to use the crimping tools and removal tools homologated by ILME (please see page E.23).																														

Materials

Insert	polycarbonate (PC)
UL 94 flame rating	V-0
Colour	pebble grey, RAL 7032
Contacts	copper alloy, silver ● and gold ● plated



CR CPQ
Coding pins
Page [E.3](#)

Enclosures size 77.62

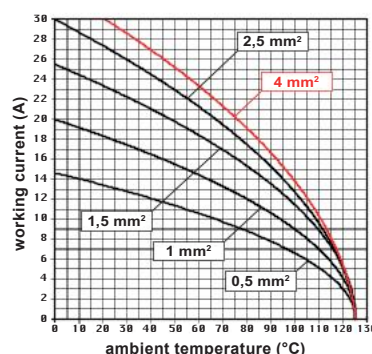
 Pages [E.78-83](#)

Heavy-Duty Applications

 Metallic with C-TYPE lever [E.78-83](#)

Aggressive Environments

 Metallic W-TYPE with C-TYPE lever [E.166-167](#)

 Metallic E-Xtreme® with C-TYPE lever [E.190-191](#)


CMCE 06 inserts max. current load derating diagram

CMCE 10 + CMCE 10 N

16 A 830 V


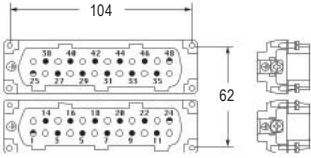

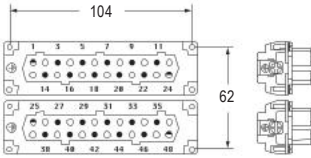
size **104.62**
20 + 4 aux. poles + ⊕

Crimp connection


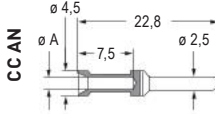

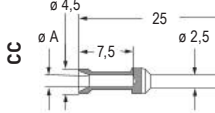

EN 61984 rating	16 A 830 V 8 kV 3
	16 A 1000 V 8 kV 2
	16 A 720 / 1250 V 8 kV 2
	auxiliary contacts: 16 A 500 V 6 kV 3
Rated voltage (UL / CSA)	600 V
Insulation resistance	≥ 10 GΩ
Contact resistance	≤ 1 mΩ
Ambient temperature limit	-40 °C ... +125 °C
Mechanical life (cycles)	≥ 500



ILME US ECBT2.E115072 | ECBT8.E115072

Item	Description	Part No.	Dimension
	Male inserts, No. (1-24) Male inserts, No. (25-48) Without contacts (to be ordered separately) ● Auxiliary contacts positions: poles 1, 24 and 25, 48	CMCEM 10 CMCEM 10 N	
	Female inserts, No. (1-24) Female inserts, No. (25-48) Without contacts (to be ordered separately) ● Auxiliary contacts positions: poles 1, 24 and 25, 48	CMCEF 10 CMCEF 10 N	

CMCE
B


	16 A advanced opening contacts	Male	Female	
	section (mm ²) section (AWG) 0,5 20 0,75 18 1 18 1,5 16 2,5 14	CC 0.5 AN CC 0.7 AN CC 1.0 AN CC 1.5 AN CC 2.5 AN		
	16 A crimp contacts section (mm ²) section (AWG) 0,14-0,37 26-22 0,5 20 0,75 18 1 18 1,5 16 2,5 14 3 12 4 12	CCMA 0.3 CCMA 0.5 CCMA 0.7 CCMA 1.0 CCMA 1.5 CCMA 2.5 CCMA 3.0 CCMA 4.0	CCFA 0.3 CCFA 0.5 CCFA 0.7 CCFA 1.0 CCFA 1.5 CCFA 2.5 CCFA 3.0 CCFA 4.0	
	0,14-0,37 26-22 0,5 20 0,75 18 1 18 1,5 16 2,5 14 3 12 4 12	CCMD 0.3 CCMD 0.5 CCMD 0.7 CCMD 1.0 CCMD 1.5 CCMD 2.5 CCMD 3.0 CCMD 4.0	CCFD 0.3 CCFD 0.5 CCFD 0.7 CCFD 1.0 CCFD 1.5 CCFD 2.5 CCFD 3.0 CCFD 4.0	

conductor section (mm ²)	conductor slot ø A (mm)	stripping length (mm)
0,14-0,37	0,9	7,5
0,5	1,1	7,5
0,75	1,3	7,5
1,0	1,45	7,5
1,5	1,8	7,5
2,5	2,2	7,5
3,0	2,55	7,5
4,0	2,85	7,5

Wire diameter: up to 4,7 mm.
For basic or high thickness gold plating, please refer to page [E.13](#)
It is recommended to use the crimping tools and removal tools homologated by ILME (please see page [E.23](#))

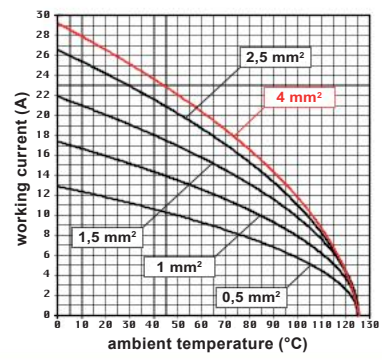
Materials

Insert	polycarbonate (PC)
UL 94 flame rating	V-0
Colour	pebble grey, RAL 7032
Contacts	copper alloy, silver ● and gold ● plated



CR CPQ
Coding pins
Page [E.3](#)

Enclosures size 104.62	Pages
Heavy-Duty Applications	
Metallic with C-TYPE lever	E.84-85
Aggressive Environments	
Metallic W-TYPE with C-TYPE lever	E.168-169
Metallic E-Xtreme® with C-TYPE lever	E.192-193



CMCE 10 inserts max. current load derating diagram

CMSH 03


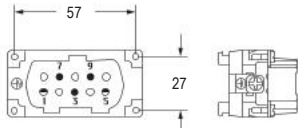

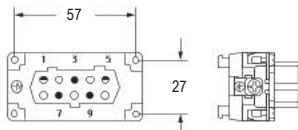
16 A 830 V

size **57.27****3 + 2 aux. poles + ⊕****Tool-less connection – SQUICH®**

EN 61984 rating	16 A 830 V 8 kV 3
	16 A 1000 V 8 kV 2
	16 A 720 / 1250 V 8 kV 2
	auxiliary contacts: 16 A 500 V 6 kV 3
Rated voltage (UL / CSA)	600 V
Insulation resistance	≥ 10 GΩ
Contact resistance	≤ 3 mΩ
Ambient temperature limit	-40 °C ... +125 °C
Mechanical life (cycles)	≥ 500

CE UK EAC

C^{AL}US ECBT2.E115072 | ECBT8.E115072

Item	Description	Part No.	Dimension
	Male inserts with male contacts Spring clamp connections, with actuator button ● Auxiliary contacts positions: poles 1 and 5	CMSHM 03	
	Female inserts with female contacts Spring clamp connections, with actuator button ● Auxiliary contacts positions: poles 1 and 5	CMSHF 03	

Materials

Insert	polycarbonate (PC)
UL 94 flame rating	V-0
Colour	pebble grey, RAL 7032
Contacts	built-in, copper alloy, silver ● plated

Wiring information

Wires cross sectional area	0,14 mm ² - 2,5 mm ² (AWG 26-14)
Stripping length	9...11 mm

Enclosures size 57.27**Pages****Heavy-Duty Applications**

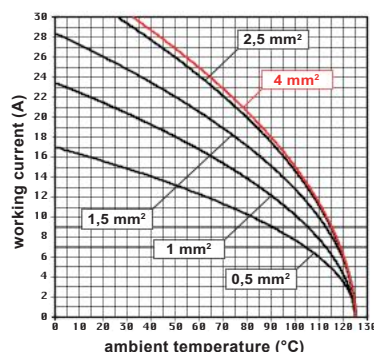
Metallic with C-TYPE lever	E.54-61
Metallic with IL-BRID lever	E.92-95, 105
Metallic with JEI®-P lever	E.113-114, 119
Metallic with V-TYPE IP67 lever	E.125, 130-131
Thermoplastic T-TYPE	E.228-229, 234-235

Aggressive Environments

Metallic IP68 high protection	E.144-145
Metallic W-TYPE	E.156-157, 163
Metallic E-Xtreme®	E.176-177, 184-185, 195
Thermoplastic T-TYPE/W	E.228-229, 234-235

Specialized Applications

EMC (Electromagnetic Shielding)	E.210-211, 217
Hygienic series for food and beverage	E.245, 248
Standard applications with Central lever	E.256-257
BIG Enclosures for multiple cable entries	E.269, 274-275
COB system for switch cabinet	E.286-289
Light and Sound applications with JEI®-P lever	E.298-299

**CMSH 03 inserts max. current load derating diagram**

CMSH 06

16 A 830 V

size **77.27**
6 + 2 aux. poles + ⊕

Tool-less connection – SQUICH®

EN 61984 rating	16 A 830 V 8 kV 3
	16 A 1000 V 8 kV 2
	16 A 720 / 1250 V 8 kV 2
	auxiliary contacts: 16 A 500 V 6 kV 3
Rated voltage (UL / CSA)	600 V
Insulation resistance	≥ 10 GΩ
Contact resistance	≤ 3 mΩ
Ambient temperature limit	-40 °C ... +125 °C
Mechanical life (cycles)	≥ 500



CAIUS ECBT2.E115072 | ECBT8.E115072

Item	Description	Part No.	Dimension
	Male inserts with male contacts Spring clamp connections, with actuator button ● Auxiliary contacts positions: poles 1 and 16	CMSHM 06	
	Female inserts with female contacts Spring clamp connections, with actuator button ● Auxiliary contacts positions: poles 1 and 16	CMSHF 06	

CMSH

B

Materials

Insert	polycarbonate (PC)
UL 94 flame rating	V-0
Colour	pebble grey, RAL 7032
Contacts	built-in, copper alloy, silver ● plated

Wiring information

Wires cross sectional area	0,14 mm ² - 2,5 mm ² (AWG 26-14)
Stripping length	9...11 mm

Enclosures size 77.27

Heavy-Duty Applications

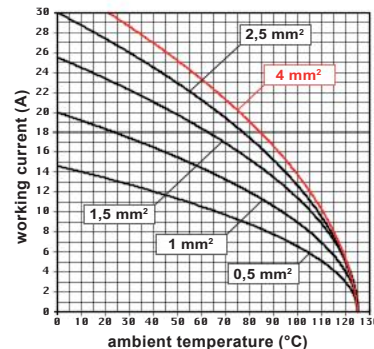
	Pages
Metallic with C-TYPE lever	E.62-69
Metallic with IL-BRID lever	E.96-99, 106
Metallic with JEI®-P lever	E.115-116, 119
Metallic with V-TYPE IP67 lever	E.126, 132-133
Thermoplastic T-TYPE	E.230-231, 234-235

Aggressive Environments

Metallic IP68 high protection	E.146-147
Metallic W-TYPE	E.158-159, 164
Metallic E-Xtreme®	E.178-179, 186-187, 196
Thermoplastic T-TYPE/W	E.230-231, 234-235

Specialized Applications

EMC (Electromagnetic Shielding)	E.212-213, 218
Hygienic series for food and beverage	E.246, 248
Standard applications with Central lever	E.258-259
BIG Enclosures for multiple cable entries	E.270, 276-277
COB system for switch cabinet	E.286-289
Light and Sound applications with JEI®-P lever	E.300-301



CMSH 06 inserts max. current load derating diagram

CMSH 10

16 A 830 V

size **104.27**

10 + 2 aux. poles + ⊕


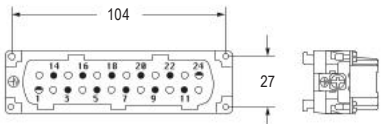

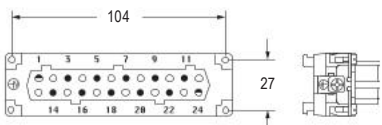
Tool-less connection – SQUICH®

EN 61984 rating	16 A 830 V 8 kV 3
	16 A 1000 V 8 kV 2
	16 A 720 / 1250 V 8 kV 2
auxiliary contacts:	16 A 500 V 6 kV 3
Rated voltage (UL / CSA)	600 V
Insulation resistance	≥ 10 GΩ
Contact resistance	≤ 3 mΩ
Ambient temperature limit	-40 °C ... +125 °C
Mechanical life (cycles)	≥ 500

CE UK EAC

CQC DNV VERITAS

C A U S E C B T 2 . E 1 1 5 0 7 2 | E C B T 8 . E 1 1 5 0 7 2

Item	Description	Part No.	Dimension
	Male inserts with male contacts Spring clamp connections, with actuator button ● Auxiliary contacts positions: poles 1 and 24	CMSHM 10	
	Female inserts with female contacts Spring clamp connections, with actuator button ● Auxiliary contacts positions: poles 1 and 24	CMSHF 10	

Materials

Insert	polycarbonate (PC)
UL 94 flame rating	V-0
Colour	pebble grey, RAL 7032
Contacts	built-in, copper alloy, silver ● plated

Wiring information

Wires cross sectional area	0,14 mm ² - 2,5 mm ² (AWG 26-14)
Stripping length	9...11 mm

Enclosures size 104.27**Pages****Heavy-Duty Applications**

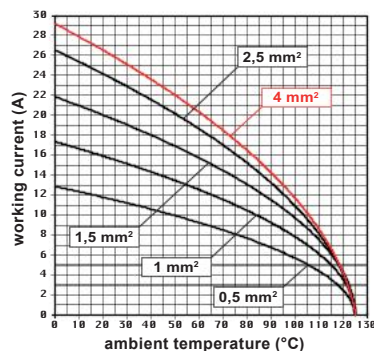
Metallic with C-TYPE lever	E.70-77
Metallic with IL-BRID lever	E.100-103 107
Metallic with JEI®-P lever	E.117-119
Metallic with V-TYPE IP67 lever	E.127 134-135
Thermoplastic T-TYPE	E.232-235

Aggressive Environments

Metallic IP68 high protection	E.148-149
Metallic W-TYPE	E.160-161 165
Metallic E-Xtreme®	E.180-181 188-189 197
Thermoplastic T-TYPE/W	E.232-235

Specialized Applications

EMC (Electromagnetic Shielding)	E.214-215 219
Hygienic series for food and beverage	E.247-248
Standard applications with Central lever	E.260-261
BIG Enclosures for multiple cable entries	E.271 278-279
COB system for switch cabinet	E.286-289
Light and Sound applications with JEI®-P lever	E.302-303

**CMSh 10 inserts max. current load derating diagram**

CMSH 06 + CMSH 06 N

16 A 830 V


size **77.62**


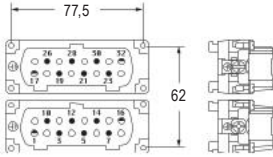

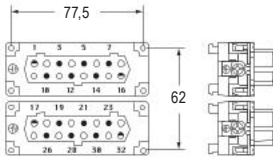
12 + 4 aux. poles + 

Tool-less connection – SQUICH®

EN 61984 rating	16 A 830 V 8 kV 3
	16 A 1000 V 8 kV 2
	16 A 720 / 1250 V 8 kV 2
	auxiliary contacts: 16 A 500 V 6 kV 3
Rated voltage (UL / CSA)	600 V
Insulation resistance	≥ 10 GΩ
Contact resistance	≤ 3 mΩ
Ambient temperature limit	-40 °C ... +125 °C
Mechanical life (cycles)	≥ 500



 ECBT2.E115072 | ECBT8.E115072

Item	Description	Part No.	Dimension
	Male inserts, No. (1-16) Male inserts, No. (17-32) Spring clamp connections, with actuator button ● Auxiliary contacts positions: poles 1, 16 and 17, 32	CMSHM 06 CMSHM 06 N	
	Female inserts, No. (1-16) Female inserts, No. (17-32) Spring clamp connections, with actuator button ● Auxiliary contacts positions: poles 1, 16 and 17, 32	CMSHF 06 CMSHF 06 N	

CMSH

B

Materials

Insert	polycarbonate (PC)
UL 94 flame rating	V-0
Colour	pebble grey, RAL 7032
Contacts	built-in, copper alloy, silver ● plated

Wiring information

Wires cross sectional area	0,14 mm ² - 2,5 mm ² (AWG 26-14)
Stripping length	9...11 mm

Enclosures size 77.62

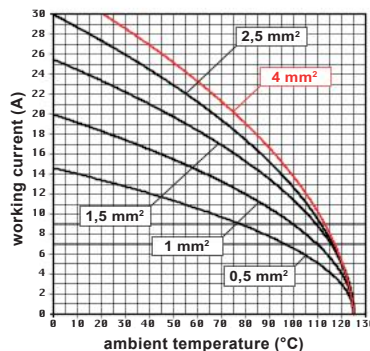
Pages 

Heavy-Duty Applications

Metallic with C-TYPE lever	E.78-83
----------------------------	-------------------------

Aggressive Environments

Metallic W-TYPE with C-TYPE lever	E.166-167
Metallic E-Xtreme® with C-TYPE lever	E.190-191



CMSH 06 inserts max. current load derating diagram

CMSH 10 + CMSH 10 N

16 A 830 V


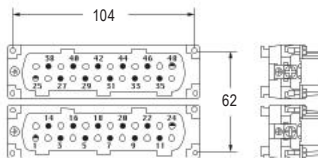

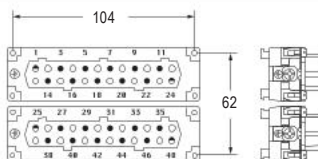
size **104.62****20 + 4 aux. poles + ⊕****Tool-less connection – SQUICH®**

EN 61984 rating	16 A 830 V 8 kV 3
	16 A 1000 V 8 kV 2
	16 A 720 / 1250 V 8 kV 2
auxiliary contacts:	16 A 500 V 6 kV 3
Rated voltage (UL / CSA)	600 V
Insulation resistance	≥ 10 GΩ
Contact resistance	≤ 3 mΩ
Ambient temperature limit	-40 °C ... +125 °C
Mechanical life (cycles)	≥ 500

CE UK EAC



C A U S ECBT2.E115072 | ECBT8.E115072

Item	Description	Part No.	Dimension
	Male inserts, No. (1-24) Male inserts, No. (25-48) Spring clamp connections, with actuator button ● Auxiliary contacts positions: poles 1, 24 and 25, 48	CMSHM 10 CMSHM 10 N	
	Female inserts, No. (1-24) Female inserts, No. (25-48) Spring clamp connections, with actuator button ● Auxiliary contacts positions: poles 1, 24 and 25, 48	CMSHF 10 CMSHF 10 N	

CM SH

B

Materials

Insert	polycarbonate (PC)
UL 94 flame rating	V-0
Colour	pebble grey, RAL 7032
Contacts	built-in, copper alloy, silver ● plated

Wiring information

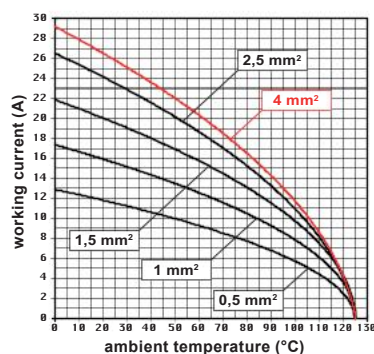
Wires cross sectional area	0,14 mm ² - 2,5 mm ² (AWG 26-14)
Stripping length	9...11 mm

Enclosures size 104.62Pages **Heavy-Duty Applications**

Metallic with C-TYPE lever	E.84-88
----------------------------	-------------------------

Aggressive Environments

Metallic W-TYPE with C-TYPE lever	E.168-169
Metallic E-Xtreme® with C-TYPE lever	E.192-193

CMSH 10 inserts max. current load derating diagram

CX and CXC

combined power / auxiliaries series



The CX and CXC connectors series offer a compact and flexible interface, combining power and signal connections in single mono-block inserts for broad use in industrial

heavy-duty applications requiring high-current feeding (100 A, 80 A and 40 A) or optimization of the wiring layout by reducing the installation space requirements.

CX 8/0 and CX 6/6 inserts series overview

The **CX 8/0 and CX 6/6 combined inserts** are suitable for currents up to 100 A and compatible with crimp contacts series CG on the power side and contacts series CC on the auxiliaries side (CX 6/6 only), offering several benefits over conventional screw or axial screw contacts in terms of resistance to mechanical stresses, vibrations, shock and cable loads.

The inserts feature the ILME innovative and patented **red** locking keys design for fastening the contact holder and reducing the assembly time. The power contacts may be removed without any special tool, using a simple screwdriver (e.g., 0,5 × 3 mm, 0,5 × 3,5 mm, 0,6 × 4 mm and 0,8 × 4 mm flat blade).

Product range

- > **CX 8/0** – 8 poles (100 A – 690 V) + ⊕ size 104.27
- > **CX 6/6** – 6 poles (100 A – 690 V) + 6 poles (16 A – 400 V) + ⊕ – size 104.27



CX 4/.. and CXC 4/.. inserts series overview

Offering four poles for up to 80 A current carrying capacity, **CX 4/0, CX 4/2, and CX 4/8 inserts** are screw-type combined connectors with additional 16 A auxiliary contacts, fully interchangeable and intermateable with the equivalent crimp version CXC 4/2 and CXC 4/8, same voltage and current ratings. Crimp versions allow conductors with cross-sectional areas up to 25 mm² / 4-3 AWG on power poles.

By employing crimp contacts (series CX7), they cover applications demanding the highest vibration resistance (e.g. railway rolling stock).



Product range, screw type

- > **CX 4/0** – 4 poles (80 A – 830 V) + ⊕ – size 77.27
- > **CX 4/2** – 4 poles (80 A – 830 V) + 2 poles (16 A - 400 V) + ⊕ – size 77.27
- > **CX 4/8** – 4 poles (80 A – 830 V) + 8 poles (16 A – 400 V) + ⊕ – size 104.27

Product range, crimp type

- > **CXC 4/2** – 4 poles (80 A – 830 V) + 2 poles (16 A – 400 V) + ⊕ – size 77.27
- > **CXC 4/8** – 4 poles (80 A – 830 V) + 8 poles (16 A – 400 V) + ⊕ – size 104.27

CX 12/2 and CX 6/12 inserts series overview

These combined connectors, in addition to the traditional lateral protective earth contact with screw connection, are provided by contact seats for 40 A CX series crimp contacts and 10 A CD series crimp contacts.

Each **CX 6/12** power pole allows wires with a rated cross-sectional area (CSA) up to 10 mm² / 8 AWG, whereas the **CX 12/2** is limited to conductors up to 6 mm² / 10 AWG rated CSA. The contacts can be used for voltages up to 230/400 V, hence also for three-phase motors of non-negligible power.



Product range

- > **CX 12/2** – 12 poles (40 A – 690 V) + 2 poles (10 A – 250 V) + ⊕ – size 77.27
- > **CX 6/12** – 6 poles (40 A – 690 V) + 12 poles (10 A – 230 / 400 V) + ⊕ – size 77.27

CX 8/0

100 A 690 V

size **104.27**
8 poles + ⊕


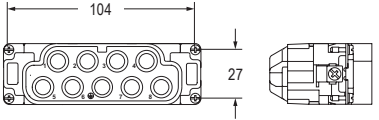

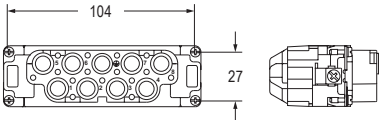

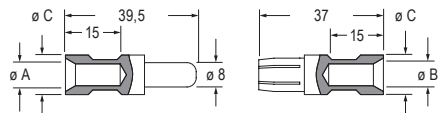
Crimp connection

EN 61984 rating	100 A 690 V 8 kV 3
Rated voltage (UL / CSA)	600 V
Insulation resistance	≥ 10 GΩ
Contact resistance	≤ 0,3 mΩ
Ambient temperature limit	-40 °C ... +125 °C
Mechanical life (cycles)	≥ 500

CE UKRA (pending: EAC)

(pending: CQC, DNV and BV)

(pending: cURus)

Item	Description	Part No.	Dimension
	Male inserts for male contacts Without contacts (to be ordered separately) The power PE contact not included (CG series)	CXM 8/0	
	Female inserts for female contacts Without contacts (to be ordered separately) The power PE contact not included (CG series)	CXF 8/0	
	100 A crimp contacts section (mm ²) section (AWG)	Male Female	
	8-10 8-7	silver	
	16 6-5	CGMA 10 CGFA 10	
	25 4-3	CGMA 16 CGFA 16	
	35 2	CGMA 25 CGFA 25	
		CGMA 35 CGFA 35	

Wiring information, CG contacts

conductor section (mm ²)	conductor slot ø A (mm)	conductor slot ø B (mm)	conductor slot ø C (mm)	stripping length (mm)
8-10	4,3	4,3	13	15
16	5,5	5,5	13	15
25	7,0	7,0	13	15
35	7,9	8,2	12,5	15

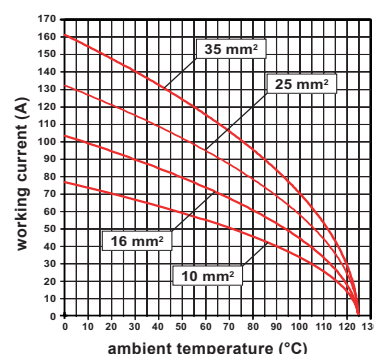
Wire diameter: up to 11,5 mm.

It is recommended to use the crimping tools and removal tools homologated by ILME (please see page F.23)

Enclosures size 104.27	Pages
Heavy-Duty Applications	
Metallic with C-TYPE lever	E.70-77
Metallic with IL-BRID lever	E.100-103,107
Metallic with JEI®-P lever	E.117-119
Metallic with V-TYPE IP67 lever	E.127,134-135
Thermoplastic T-TYPE	E.232-235
Aggressive Environments	
Metallic IP68 high protection	E.148-149
Metallic W-TYPE	E.160-161,165
Metallic E-Xtreme®	E.180-181,188-189,197
Thermoplastic T-TYPE/W	E.232-235
Specialized Applications	
EMC (Electromagnetic Shielding)	E.214-215,219
Hygienic series for food and beverage	E.247-248
Standard applications with Central lever	E.260-261
BIG Enclosures for multiple cable entries	E.271,278-279
COB system for switch cabinet	E.286-289
Light and Sound applications with JEI®-P lever	E.302-303

Materials

Insert	polycarbonate (PC)
UL 94 flame rating	V-0
Colour	pebble grey, RAL 7032
Contacts	copper alloy, silver ● plated



CX 8/0 inserts max. current load derating diagram

Can be used in bulkhead mounting housings or in high construction housings or in high construction hoods.

CX 6/6

100 A 690 V / 16 A 400 V

size **104.27**

6 / 6 poles + ⊕

Crimp connection

EN 61984 rating	100 A 690 V 8 kV 3	16 A 400 V 6 kV 3
Rated voltage (UL / CSA)	600 V	
Insulation resistance	≥ 10 GΩ	
Contact resistance	100 A (6 poles)*	≤ 0,3 mΩ
	16 A (6 poles)	≤ 1 mΩ
Ambient temperature limit	-40 °C ... +125 °C	
Mechanical life (cycles)	≥ 500	



ECBT2.E115072 | ECBT8.E115072
(pending: PVVA2.E506437 | PVVA8.E506437)

Item	Description	Part No.	Dimension
	Male inserts for male contacts Without contacts (to be ordered separately) * The power PE contact not included (CG series)	CXM 6/6	

	Female inserts for female contacts Without contacts (to be ordered separately) * The power PE contact not included (CG series)	CXF 6/6	
--	--	-------------------------	--

	100 A crimp contacts	16 A crimp contacts	Male	Female	
	section (mm ²) section (AWG) 8-10 8-7 16 6-5 25 4-3 35 2	section (mm ²) section (AWG) 0,14-0,37 26-22 0,5 20 0,75 18 1 18 1,5 16 2,5 14 3 12 4 12	silver	silver	
			silver	silver	
			gold	gold	

Wiring information, CG and CC contacts

conductor section (mm ²)	conductor slot ø A (mm)	conductor slot ø B (mm)	conductor slot ø C (mm)	conductor section (mm ²)	conductor slot ø D (mm)
8-10	4,3	4,3	13	0,14-0,37	0,9
16	5,5	5,5	13	0,5	1,1
25	7,0	7,0	13	0,75	1,3
35	7,9	8,2	12,5	1,0	1,45
-	-	-	-	1,5	1,8
-	-	-	-	2,5	2,2
-	-	-	-	3,0	2,55
-	-	-	-	4,0	2,85

Wire diameter: up to 11,5 mm (CG series); up to 4,7 mm (CC series).

For basic or high thickness gold plating, please refer to page [F.13](#).

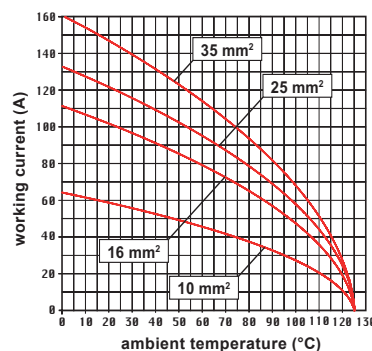
It is recommended to use the crimping tools and removal tools homologated by ILME (please see page [F.23](#)).

Enclosures size 104.27	Pages
Heavy-Duty Applications	
Metallic with C-TYPE lever	E.70-77
Metallic with IL-BRID lever	E.100-103 , 107
Metallic with JEI®-P lever	E.117-119
Metallic with V-TYPE IP67 lever	E.127 , 134-135
Thermoplastic T-TYPE	E.232-235
Aggressive Environments	
Metallic IP68 high protection	E.148-149
Metallic W-TYPE	E.160-161 , 165
Metallic E-Xtreme®	E.180-181 , 188-189 , 197
Thermoplastic T-TYPE/W	E.232-235
Specialized Applications	
EMC (Electromagnetic Shielding)	E.214-215 , 219
Hygienic series for food and beverage	E.247-248
Standard applications with Central lever	E.260-261
BIG Enclosures for multiple cable entries	E.271 , 278-279
COB system for switch cabinet	E.286-289
Light and Sound applications with JEI®-P lever	E.302-303

Can be used in bulkhead mounting housings or in high construction housings or in high construction hoods.

Materials

Insert	polycarbonate (PC)
UL 94 flame rating	V-0
Colour	pebble grey, RAL 7032
Contacts	copper alloy, silver ● and gold ● plated



CX 6/6 inserts max. current load derating diagram

CX 4/0


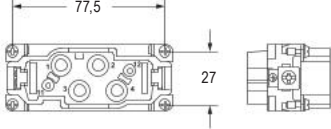

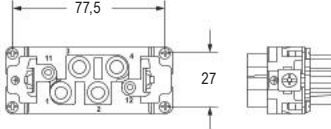
80 A 830 V

size **77.27**
4 poles + ⊕

Screw connection

EN 61984 rating	80 A 830 V 8 kV 3
Rated voltage (UL / CSA)	600 V
Insulation resistance	≥ 10 GΩ
Contact resistance	≤ 0,3 mΩ
Ambient temperature limit	-40 °C ... +125 °C
Mechanical life (cycles)	≥ 500

ECBT2.E115072 | ECBT8.E115072

Item	Description	Part No.	Dimension
	Male inserts for male contacts	CXM 4/0	
	Female inserts for female contacts	CXF 4/0	

Materials

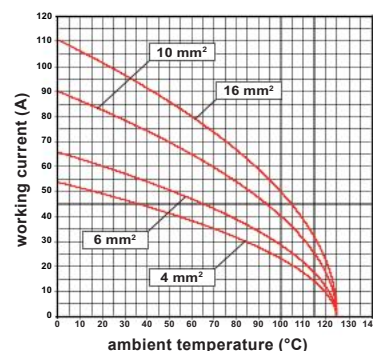
Insert	polycarbonate (PC)
UL 94 flame rating	V-0
Colour	pebble grey, RAL 7032
Contacts	built-in, copper alloy, silver ● plated

Wiring information

Wires cross sectional area	4 mm ² - 16 mm ² (AWG 12-6)
Stripping length	14 mm
Terminal screw torque	2,5 Nm (22.1 lb.in)

Enclosures size 77.27	Pages
Heavy-Duty Applications	
Metallic with C-TYPE lever	E.62-69
Metallic with IL-BRID lever	E.96-99, 106
Metallic with JEI®-P lever	E.115-116, 119
Metallic with V-TYPE IP67 lever	E.126, 132-133
Thermoplastic T-TYPE	E.230-231, 234-235
Aggressive Environments	
Metallic IP68 high protection	E.146-147
Metallic W-TYPE	E.158-159, 164
Metallic E-Xtreme®	E.178-179, 186-187, 196
Thermoplastic T-TYPE/W	E.230-231, 234-235
Specialized Applications	
EMC (Electromagnetic Shielding)	E.212-213, 216
Hygienic series for food and beverage	E.246, 248
Standard applications with Central lever	E.258-259
BIG Enclosures for multiple cable entries	E.270, 276-277
COB system for switch cabinet	E.286-289
Light and Sound applications with JEI®-P lever	E.300-301

CX 4/0 inserts max. current load derating diagram



Can be used in bulkhead mounting housings or in high construction housings or in high construction hoods.

CX 4/2

80 A 830 V / 16 A 400 V

size **77.27**
4 / 2 poles + ⊕


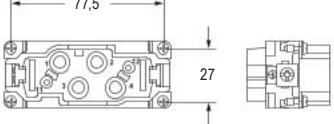

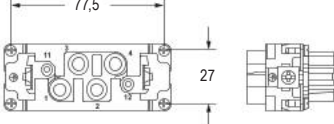
Screw connection

EN 61984 rating	80 A 830 V 8 kV 3
	16 A 400 V 6 kV 3 / 16 A 400/690 V 6 kV 2
Rated voltage (UL / CSA)	600 V
Insulation resistance	≥ 10 GΩ
Contact resistance	80 A (4 poles) ≤ 0,3 mΩ
	16 A (2 poles) ≤ 1 mΩ
Ambient temperature limit	-40 °C ... +125 °C
Mechanical life (cycles)	≥ 500

CE UK EAC



CAIUS ECBT2.E115072 | ECBT8.E115072

Item	Description	Part No.	Dimension
	Male inserts for male contacts	CXM 4/2	
	Female inserts for female contacts	CXF 4/2	

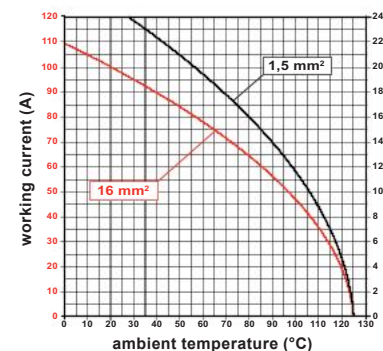
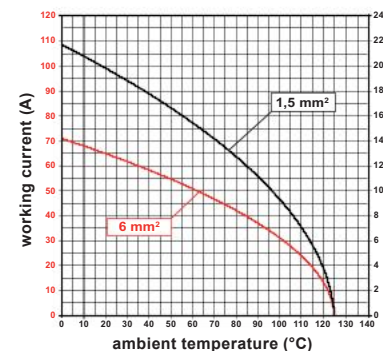
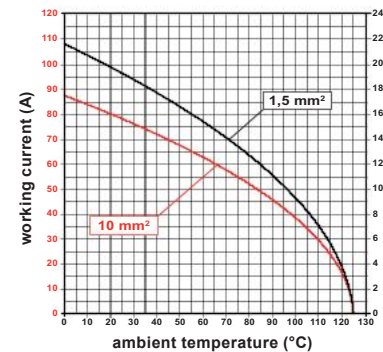
Materials

Insert	polycarbonate (PC)
UL 94 flame rating	V-0
Colour	pebble grey, RAL 7032
Contacts	built-in, copper alloy, silver ● plated

Wiring information

Wires cross sectional area	
- 80 A contacts	4 mm ² - 16 mm ² (AWG 12-6)
- 16 A contacts	0,25 mm ² - 2,5 mm ² (AWG 24-14)
Stripping length	
- 80 A contacts	14 mm
- 16 A contacts	7 mm
Terminal screw torque	
- 80 A contacts	2,5 Nm (22.1 lb.in)
- 16 A contacts	0,5 Nm (4.4 lb.in)

CX 4/2 inserts max. current load derating diagrams



Enclosures size 77.27

Pages

Heavy-Duty Applications	
Metallic with C-TYPE lever	E.62-69
Metallic with IL-BRID lever	E.96-99, 106
Metallic with JEI®-P lever	E.115-116, 119
Metallic with V-TYPE IP67 lever	E.126, 132-133
Thermoplastic T-TYPE	E.230-231, 234-235
Aggressive Environments	
Metallic IP68 high protection	E.146-147
Metallic W-TYPE	E.158-159, 164
Metallic E-Xtreme®	E.178-179, 186-187, 196
Thermoplastic T-TYPE/W	E.230-231, 234-235
Specialized Applications	
EMC (Electromagnetic Shielding)	E.212-213, 216
Hygienic series for food and beverage	E.246, 248
Standard applications with Central lever	E.258-259
BIG Enclosures for multiple cable entries	E.270, 276-277
COB system for switch cabinet	E.286-289
Light and Sound applications with JEI®-P lever	E.300-301

Can be used in bulkhead mounting housings or in high construction housings or in high construction hoods.

Any cross-sectional area on the signal side higher than that combined to the relevant cross-sectional area on the power side may be used, but with the derating curve for the cross-sectional area given as combined to that on the power side.

CXC 4/2

80 A 830 V / 16 A 400 V

size **77.27**
4 / 2 poles + ⊕

Crimp connection

EN 61984 rating	80 A 830 V 8 kV 3	16 A 400 V 6 kV 3
Rated voltage (UL / CSA)	600 V	
Insulation resistance	≥ 10 GΩ	
Contact resistance	80 A (4 poles)	≤ 0,3 mΩ
	16 A (2 poles)	≤ 1 mΩ
Ambient temperature limit	-40 °C ... +125 °C	
Mechanical life (cycles)	≥ 500	

CE UK (pending: EAC)

(pending: CQC, DNV and BV)

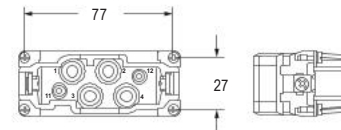
(pending: cURus)

Item	Description	Part No.	Dimension
------	-------------	----------	-----------



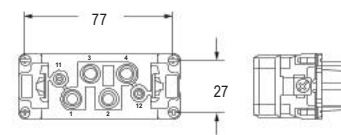
Male inserts for male contacts
Without contacts
(to be ordered separately)

[CXCM 4/2](#)



Female inserts for female contacts
Without contacts
(to be ordered separately)

[CXCF 4/2](#)



80 A crimp contacts

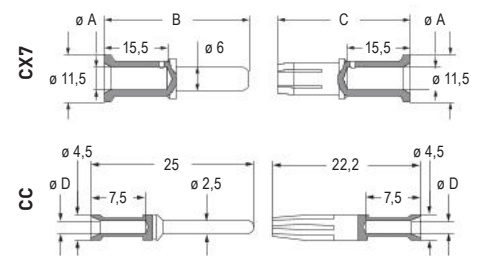
section (mm ²)	section (AWG)
6	10
10	8-7
16	6-5
16 (XF)*	6-5
25	4-3

Male

Female

silver

CX7MA 6.0	CX7FA 6.0
CX7MA 10	CX7FA 10
CX7MA 16	CX7FA 16
CX7MA 16 XF	CX7FA 16 XF
CX7MA 25	CX7FA 25



Wiring information, CX7 and CC contacts

conductor section (mm ²)	conductor slot ø A (mm)	length B (mm)	length C (mm)	conductor section (mm ²)	conductor slot ø D (mm)
6	3,5	36,0	33,0	0,14-0,37	0,9
10	4,3	35,2	32,2	0,5	1,1
16	5,5	35,2	32,2	0,75	1,3
16 (XF)	6,1	35,2	32,2	1,0	1,45
25	7,0	35,2	32,2	1,5	1,8
-	-	-	-	2,5	2,2
-	-	-	-	3,0	2,55
-	-	-	-	4,0	2,85

16 A crimp contacts

section (mm ²)	section (AWG)
0,14-0,37	26-22
0,5	20
0,75	18
1	18
1,5	16
2,5	14
3	12
4	12

silver

CCMA 0.3	CCFA 0.3
CCMA 0.5	CCFA 0.5
CCMA 0.7	CCFA 0.7
CCMA 1.0	CCFA 1.0
CCMA 1.5	CCFA 1.5
CCMA 2.5	CCFA 2.5
CCMA 3.0	CCFA 3.0
CCMA 4.0	CCFA 4.0

* for extra-flexible Class 6 conductors

Wire diameter: up to 10 mm (CX7 series); up to 4,7 mm (CC series).
It is recommended to use the crimping tools and removal tools homologated by ILME (please see page [F.23](#))

Materials

Insert	polycarbonate (PC)
UL 94 flame rating	V-0
Colour	pebble grey, RAL 7032
Contacts	copper alloy, silver ● plated

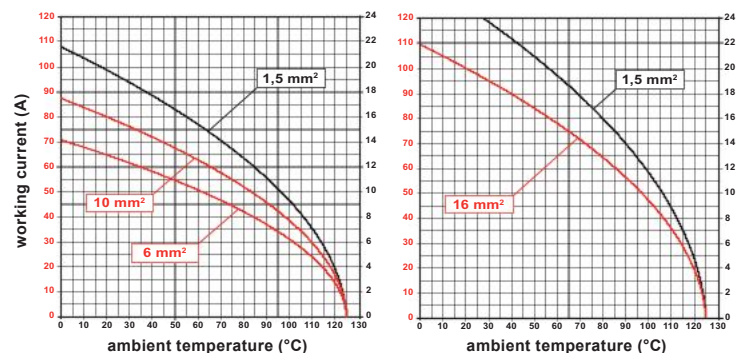
Enclosures size 77.27

Pages

Heavy-Duty Applications	Pages
Metallic with C-TYPE lever	E.62-69
Metallic with IL-BRID lever	E.96-99, 106
Metallic with JEI®-P lever	E.115-116, 119
Metallic with V-TYPE IP67 lever	E.126, 132-133
Thermoplastic T-TYPE	E.230-231, 234-235
Aggressive Environments	Pages
Metallic IP68 high protection	E.146-147
Metallic W-TYPE	E.158-159, 164
Metallic E-Xtreme®	E.178-179, 186-187, 196
Thermoplastic T-TYPE/W	E.230-231, 234-235
Specialized Applications	Pages
EMC (Electromagnetic Shielding)	E.212-213, 216
Hygienic series for food and beverage	E.246, 248
Standard applications with Central lever	E.258-259
BIG Enclosures for multiple cable entries	E.270, 276-277
COB system for switch cabinet	E.286-289
Light and Sound applications with JEI®-P lever	E.300-301

Can be used in bulkhead mounting housings or in high construction housings or in high construction hoods.

CXC 4/2 inserts max. current load derating diagrams



CX 4/8


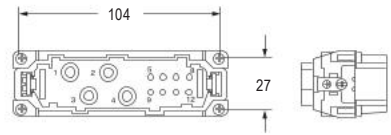

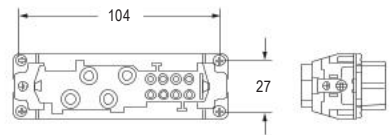
80 A 400 V / 16 A 230/400 Vsize **104.27**
4 / 8 poles + ⊕

Screw connection

EN 61984 rating	80 A 400 V 6 kV 3 / 80 A 400 / 690 V 6 kV 2
	16 A 230 / 400 V 4 kV 3 / 16 A 400 V 4 kV 2
Rated voltage (UL / CSA)	600 V
Insulation resistance	≥ 10 GΩ
Contact resistance	80 A (4 poles) ≤ 0,3 mΩ
	16 A (8 poles) ≤ 1 mΩ
Ambient temperature limit	-40 °C ... +125 °C
Mechanical life (cycles)	≥ 500

CE UK EAC

C^{AL}US ECBT2.E115072 | ECBT8.E115072

Item	Description	Part No.	Dimension
	Male inserts for male contacts	CXM 4/8	
	Female inserts for female contacts	CXF 4/8	

Materials

Insert	polycarbonate (PC)
UL 94 flame rating	V-0
Colour	pebble grey, RAL 7032
Contacts	built-in, copper alloy, silver ● plated

Wiring information

Wires cross sectional area	
- 80 A contacts	4 mm ² - 16 mm ² (AWG 12-6)
- 16 A contacts	0,25 mm ² - 2,5 mm ² (AWG 24-14)
Stripping length	
- 80 A contacts	14 mm
- 16 A contacts	7 mm
Terminal screw torque	
- 80 A contacts	2,5 Nm (22.1 lb.in)
- 16 A contacts	0,5 Nm (4.4 lb.in)

Any cross-sectional area in the signal side higher than that combined to the relevant cross-sectional area on the power side may be used, but with the derating curve for the cross-sectional area given as combined to that on the power side.

Any cross-sectional area in the signal side lower than that combined to the relevant cross-sectional area on the power side (e.g. 1 mm² signal with 16 mm² power) may be used at the current indicated to for the signal cross-sectional area belonging to the closest lower cross-sectional area on the power side (i.e. the 1 mm² curve combined to the 6 mm² power section).

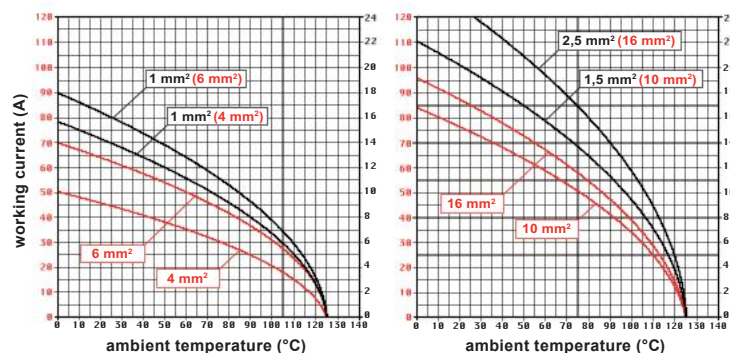
The derating curves for the connector's **power** and **signal** poles in the diagrams below are valid for the following combinations:

- power 4 mm² with signal 1 mm²;
- power 6 mm² with signal 1 mm²;
- power 10 mm² or 6 mm² with signal 1,5 mm²;
- power 16 mm² with signal 2,5 mm².

Enclosures size 104.27	Pages
Heavy-Duty Applications	
Metallic with C-TYPE lever	E.70-77
Metallic with IL-BRID lever	E.100-103, 107
Metallic with JEI®-P lever	E.117-119
Metallic with V-TYPE IP67 lever	E.127, 134-135
Thermoplastic T-TYPE	E.232-235
Aggressive Environments	
Metallic IP68 high protection	E.148-149
Metallic W-TYPE	E.160-161, 165
Metallic E-Xtreme®	E.180-181, 188-189, 197
Thermoplastic T-TYPE/W	E.232-235
Specialized Applications	
EMC (Electromagnetic Shielding)	E.214-215, 219
Hygienic series for food and beverage	E.247-248
Standard applications with Central lever	E.260-261
BIG Enclosures for multiple cable entries	E.271, 278-279
COB system for switch cabinet	E.286-289
Light and Sound applications with JEI®-P lever	E.302-303

Can be used in bulkhead mounting housings or in high construction housings or in high construction hoods.

CX 4/8 inserts max. current load derating diagrams



CXC 4/8

80 A 400 V / 16 A 230/400 V

size **104.27**

4 / 8 poles + ⊕

Crimp connection

EN 61984 rating	80 A 400 V 6 kV 3
	16 A 230 / 400 V 4 kV 3
Rated voltage (UL / CSA)	600 V
Insulation resistance	≥ 10 GΩ
Contact resistance	80 A (4 poles) ≤ 0,3 mΩ
	16 A (8 poles) ≤ 1 mΩ
Ambient temperature limit	-40 °C ... +125 °C
Mechanical life (cycles)	≥ 500

CE UK (pending: EAC)

(pending: CQC, DNV and BV)

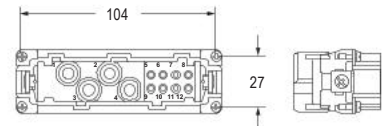
(pending: cURus)

Item	Description	Part No.	Dimension
------	-------------	----------	-----------



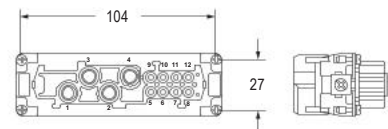
Male inserts for male contacts
Without contacts
(to be ordered separately)

[CXXM 4/8](#)



Female inserts for female contacts
Without contacts
(to be ordered separately)

[CXXF 4/8](#)



80 A crimp contacts

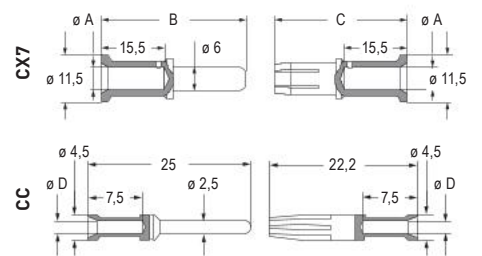
section (mm ²)	section (AWG)
6	10
10	8-7
16	6-5
16 (XF)*	6-5
25	4-3

Male

Female

silver

CX7MA 6.0	CX7FA 6.0
CX7MA 10	CX7FA 10
CX7MA 16	CX7FA 16
CX7MA 16 XF	CX7FA 16 XF
CX7MA 25	CX7FA 25



16 A crimp contacts

section (mm ²)	section (AWG)
0,14-0,37	26-22
0,5	20
0,75	18
1	18
1,5	16
2,5	14
3	12
4	12

silver

CCMA 0.3	CCFA 0.3
CCMA 0.5	CCFA 0.5
CCMA 0.7	CCFA 0.7
CCMA 1.0	CCFA 1.0
CCMA 1.5	CCFA 1.5
CCMA 2.5	CCFA 2.5
CCMA 3.0	CCFA 3.0
CCMA 4.0	CCFA 4.0

Wiring information, CX7 and CC contacts

conductor section (mm ²)	conductor slot ø A (mm)	length B (mm)	length C (mm)	conductor section (mm ²)	conductor slot ø D (mm)
6	3,5	36,0	33,0	0,14-0,37	0,9
10	4,3	35,2	32,2	0,5	1,1
16	5,5	35,2	32,2	0,75	1,3
16 (XF)	6,1	35,2	32,2	1,0	1,45
25	7,0	35,2	32,2	1,5	1,8
-	-	-	-	2,5	2,2
-	-	-	-	3,0	2,55
-	-	-	-	4,0	2,85

* for extra-flexible Class 6 conductors

Wire diameter: up to 10 mm (CX7 series); up to 4,7 mm (CC series).

It is recommended to use the crimping tools and removal tools homologated by ILME (please see page F.23)

Materials

Insert	polycarbonate (PC)
UL 94 flame rating	V-0
Colour	pebble grey, RAL 7032
Contacts	copper alloy, silver ● plated

Enclosures size 104.27 Pages

Heavy-Duty Applications	Pages
Metallic with C-TYPE lever	E.70-77
Metallic with IL-BRID lever	E.100-103, 107
Metallic with JEI®-P lever	E.117-119
Metallic with V-TYPE IP67 lever	E.127, 134-135
Thermoplastic T-TYPE	E.232-235

Aggressive Environments	Pages
Metallic IP68 high protection	E.148-149
Metallic W-TYPE	E.160-161, 165
Metallic E-Xtreme®	E.180-181, 188-189, 197
Thermoplastic T-TYPE/W	E.232-235

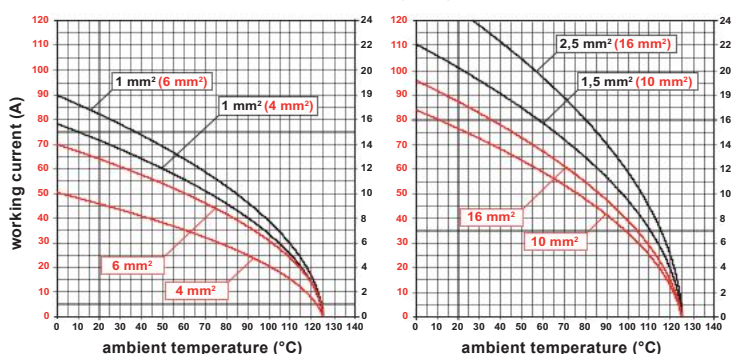
Specialized Applications	Pages
EMC (Electromagnetic Shielding)	E.214-215, 219
Hygienic series for food and beverage	E.247-248
Standard applications with Central lever	E.260-261
BIG Enclosures for multiple cable entries	E.271, 278-279
COB system for switch cabinet	E.286-289
Light and Sound applications with JEI®-P lever	E.302-303

Can be used in bulkhead mounting housings or in high construction housings or in high construction hoods.

The derating curves for the connector's power and signal poles in the diagrams below are valid for the following combinations:

- power 4 mm² with signal 1 mm²;
- power 6 mm² with signal 1 mm²;
- power 10 mm² or 6 mm² with signal 1,5 mm²;
- power 16 mm² with signal 2,5 mm².

CXC 4/8 inserts max. current load derating diagrams



CX 12/2

40 A 690 V / 10 A 250 V

size **77.27**

12 / 2 poles + ⊕

Crimp connection

EN 61984 rating	40 A 690 V 8 kV 3
	10 A 250 V 4 kV 3
Rated voltage (UL / CSA)	600 V
Insulation resistance	≥ 10 GΩ
Contact resistance	40 A (12 poles) ≤ 0,3 mΩ
	10 A (2 poles) ≤ 1 mΩ
Ambient temperature limit	-40 °C ... +125 °C
Mechanical life (cycles)	≥ 500

CE UK EAC

ECBT2.E115072 | ECBT8.E115072

Item	Description	Part No.	Dimension																																										
	Male inserts for male contacts Without contacts (to be ordered separately)	CXM 12/2																																											
	Female inserts for female contacts Without contacts (to be ordered separately)	CXF 12/2																																											
	40 A crimp contacts section (mm ²) section (AWG)	Male	Female																																										
	1,5 16	CXMA 1.5	CXFA 1.5																																										
	2,5 14	CXMA 2.5	CXFA 2.5																																										
	4 12	CXMA 4.0	CXFA 4.0																																										
	6 10	CXMA 6.0	CXFA 6.0																																										
	10 A crimp contacts section (mm ²) section (AWG)																																												
	0,14-0,37 26-22	CDMA 0.3	CDFA 0.3																																										
	0,5 20	CDMA 0.5	CDFA 0.5																																										
	0,75 18	CDMA 0.7	CDFA 0.7																																										
	1 18	CDMA 1.0	CDFA 1.0																																										
	1,5 16	CDMA 1.5	CDFA 1.5																																										
	2,5 14	CDMA 2.5	CDFA 2.5																																										
	0,14-0,37 26-22	CDMD 0.3	CDFD 0.3																																										
	0,5 20	CDMD 0.5	CDFD 0.5																																										
	0,75 18	CDMD 0.7	CDFD 0.7																																										
	1 18	CDMD 1.0	CDFD 1.0																																										
	1,5 16	CDMD 1.5	CDFD 1.5																																										
	2,5 14	CDMD 2.5	CDFD 2.5																																										
			Wiring information, CX and CD contacts																																										
			<table border="1"> <thead> <tr> <th>conductor section (mm²)</th> <th>conductor slot ø A (mm)</th> <th>stripping length B (mm)</th> <th>conductor section (mm²)</th> <th>conductor slot ø C (mm)</th> <th>stripping length D (mm)</th> </tr> </thead> <tbody> <tr> <td>1,5</td> <td>1,8</td> <td>9</td> <td>0,14-0,37</td> <td>0,9</td> <td>8</td> </tr> <tr> <td>2,5</td> <td>2,2</td> <td>9</td> <td>0,5</td> <td>1,1</td> <td>8</td> </tr> <tr> <td>4</td> <td>2,85</td> <td>9,6</td> <td>0,75</td> <td>1,3</td> <td>8</td> </tr> <tr> <td>6</td> <td>3,5</td> <td>9,6</td> <td>1,0</td> <td>1,45</td> <td>8</td> </tr> <tr> <td>-</td> <td>-</td> <td>-</td> <td>1,5</td> <td>1,8</td> <td>8</td> </tr> <tr> <td>-</td> <td>-</td> <td>-</td> <td>2,5</td> <td>2,2</td> <td>6</td> </tr> </tbody> </table>	conductor section (mm ²)	conductor slot ø A (mm)	stripping length B (mm)	conductor section (mm ²)	conductor slot ø C (mm)	stripping length D (mm)	1,5	1,8	9	0,14-0,37	0,9	8	2,5	2,2	9	0,5	1,1	8	4	2,85	9,6	0,75	1,3	8	6	3,5	9,6	1,0	1,45	8	-	-	-	1,5	1,8	8	-	-	-	2,5	2,2	6
conductor section (mm ²)	conductor slot ø A (mm)	stripping length B (mm)	conductor section (mm ²)	conductor slot ø C (mm)	stripping length D (mm)																																								
1,5	1,8	9	0,14-0,37	0,9	8																																								
2,5	2,2	9	0,5	1,1	8																																								
4	2,85	9,6	0,75	1,3	8																																								
6	3,5	9,6	1,0	1,45	8																																								
-	-	-	1,5	1,8	8																																								
-	-	-	2,5	2,2	6																																								
			Wire diameter: up to 5,3 mm (CX series); up to 3,8 mm (CD series).																																										
			For basic or high thickness gold plating, please refer to page E.16 .																																										
			It is recommended to use the crimping tools and removal tools homologated by ILME (please see page E.23).																																										

Materials

Insert	polycarbonate (PC)
UL 94 flame rating	V-0
Colour	pebble grey, RAL 7032
Contacts	copper alloy, silver ● and gold ● plated

Enclosures size 77.27

Pages

Heavy-Duty Applications

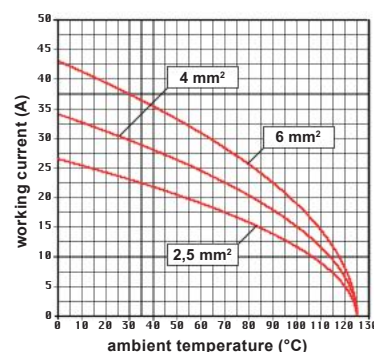
Metallic with C-TYPE lever	E.62-69
Metallic with IL-BRID lever	E.96-99 106
Metallic with JEI®-P lever	E.115-116 119
Metallic with V-TYPE IP67 lever	E.126 132-133
Thermoplastic T-TYPE	E.230-231 234-235

Aggressive Environments

Metallic IP68 high protection	E.146-147
Metallic W-TYPE	E.158-159 164
Metallic E-Xtreme®	E.178-179 186-187 196
Thermoplastic T-TYPE/W	E.230-231 234-235

Specialized Applications

EMC (Electromagnetic Shielding)	E.212-213 216
Hygienic series for food and beverage	E.246 248
Standard applications with Central lever	E.258-259
BIG Enclosures for multiple cable entries	E.270 276-277
COB system for switch cabinet	E.286-289
Light and Sound applications with JEI®-P lever	E.300-301



CX 12/2 inserts max. current load derating diagram

CX 6/12


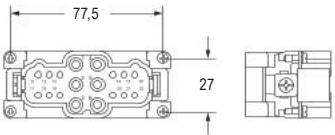
40 A 690 V / 10 A 230/400 V


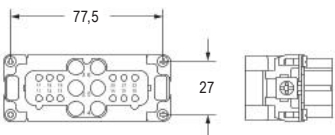
size **77.27**
6 / 12 poles + ⊕


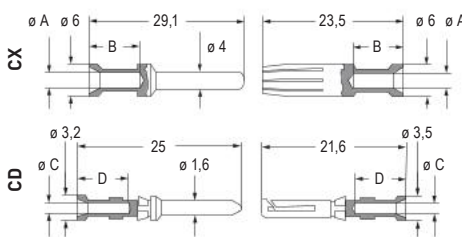


Crimp connection

EN 61984 rating	40 A 690 V 8 kV 3
	10 A 230 / 400 V 4 kV 3
Rated voltage (UL / CSA)	600 V
Insulation resistance	≥ 10 GΩ
Contact resistance	40 A (6 poles) ≤ 0,3 mΩ
	10 A (12 poles) ≤ 1 mΩ
Ambient temperature limit	-40 °C ... +125 °C
Mechanical life (cycles)	≥ 500



Item	Description	Part No.	Dimension
	Male inserts for male contacts Without contacts (to be ordered separately)	CXM 6/12	

	Female inserts for female contacts Without contacts (to be ordered separately)	CXF 6/12	
---	--	--------------------------	---

	40 A crimp contacts	10 A crimp contacts	Male	Female	
	section (mm ²) section (AWG)	section (mm ²) section (AWG)			
	1,5 16	0,14-0,37 26-22	silver		
	2,5 14	0,5 20	CXMA 1.5	CXFA 1.5	
	4 12	0,75 18	CXMA 2.5	CXFA 2.5	
	6 10	1 18	CXMA 4.0	CXFA 4.0	
	10 8	1,5 16	CXMA 6.0	CXFA 6.0	
		2,5 14	CXMA 10	CXFA 10	
	section (mm ²) section (AWG)	section (mm ²) section (AWG)	silver		
	0,14-0,37 26-22	0,14-0,37 26-22	CDMA 0.3	CDFA 0.3	
	0,5 20	0,5 20	CDMA 0.5	CDFA 0.5	
	0,75 18	0,75 18	CDMA 0.7	CDFA 0.7	
	1 18	1 18	CDMA 1.0	CDFA 1.0	
	1,5 16	1,5 16	CDMA 1.5	CDFA 1.5	
	2,5 14	2,5 14	CDMA 2.5	CDFA 2.5	
	section (mm ²) section (AWG)	section (mm ²) section (AWG)	gold		
	0,14-0,37 26-22	0,14-0,37 26-22	CDMD 0.3	CDFD 0.3	
	0,5 20	0,5 20	CDMD 0.5	CDFD 0.5	
	0,75 18	0,75 18	CDMD 0.7	CDFD 0.7	
	1 18	1 18	CDMD 1.0	CDFD 1.0	
	1,5 16	1,5 16	CDMD 1.5	CDFD 1.5	
	2,5 14	2,5 14	CDMD 2.5	CDFD 2.5	

Wiring information, CX and CD contacts

conductor section (mm ²)	conductor slot ø A (mm)	stripping length B (mm)	conductor section (mm ²)	conductor slot ø C (mm)	stripping length D (mm)
1,5	1,8	9	0,14-0,37	0,9	8
2,5	2,2	9	0,5	1,1	8
4	2,85	9,6	0,75	1,3	8
6	3,5	9,6	1,0	1,45	8
10	4,3	15	1,5	1,8	8
-	-	-	2,5	2,2	6

Wire diameter: up to 7 mm (CX series); up to 3,8 mm (CD series).

For basic or high thickness gold plating, please refer to page [F.16](#)

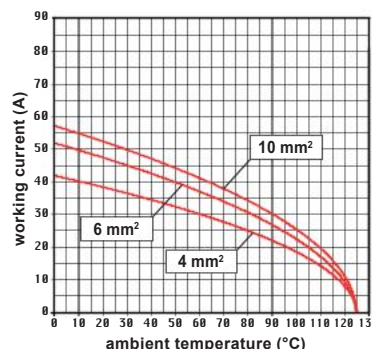
It is recommended to use the crimping tools and removal tools homologated by ILME (please see page [F.23](#))

Materials

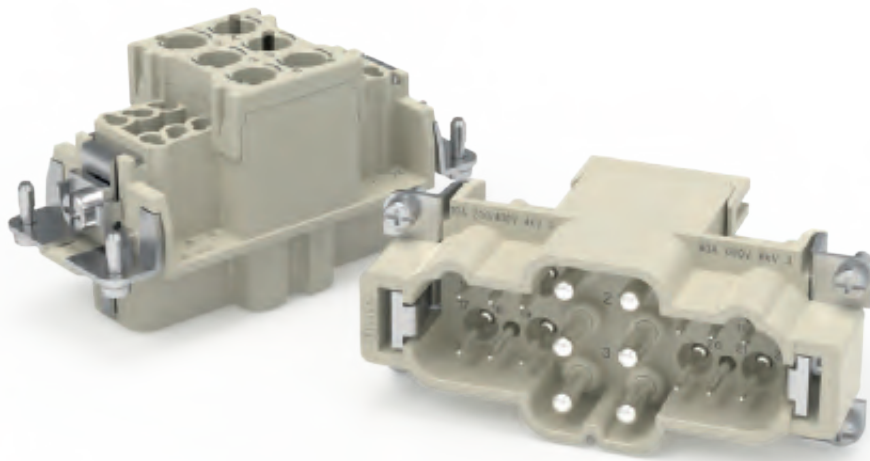
Insert	polycarbonate (PC)
UL 94 flame rating	V-0
Colour	pebble grey, RAL 7032
Contacts	copper alloy, silver ● and gold ● plated

Enclosures size 77.27

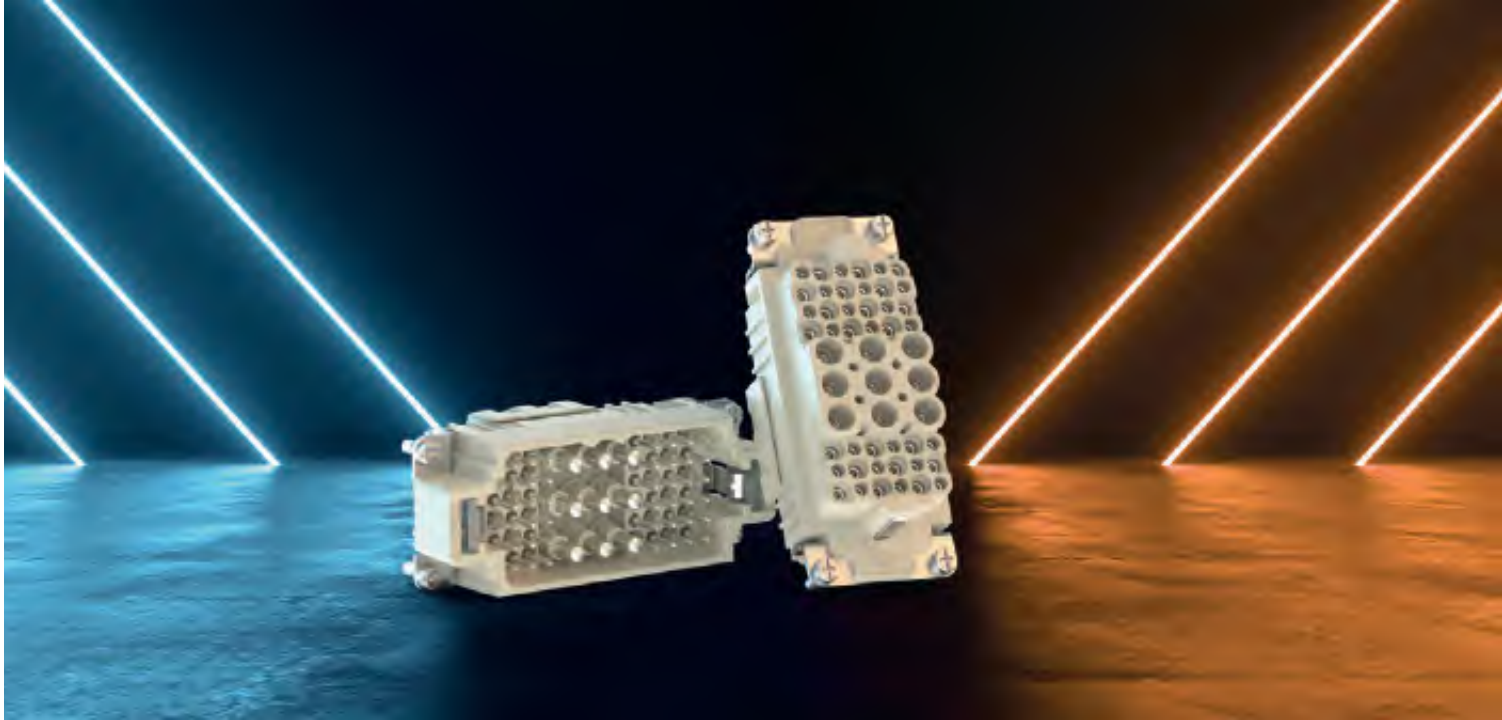
Heavy-Duty Applications	Pages
Metallic with C-TYPE lever	E.62-69
Metallic with IL-BRID lever	E.96-99 , 106
Metallic with JEI®-P lever	E.115-116 , 119
Metallic with V-TYPE IP67 lever	E.126 , 132-133
Thermoplastic T-TYPE	E.230-231 , 234-235
Aggressive Environments	
Metallic IP68 high protection	E.146-147
Metallic W-TYPE	E.158-159 , 164
Metallic E-Xtreme®	E.178-179 , 186-187 , 196
Thermoplastic T-TYPE/W	E.230-231 , 234-235
Specialized Applications	
EMC (Electromagnetic Shielding)	E.212-213 , 216
Hygienic series for food and beverage	E.246 , 248
Standard applications with Central lever	E.258-259
BIG Enclosures for multiple cable entries	E.270 , 276-277
COB system for switch cabinet	E.286-289
Light and Sound applications with JEI®-P lever	E.300-301



CX 6/12 inserts max. current load derating diagram



CX series, combined power / auxiliaries series in a compact size



The CX 9/42, CX 6/36 and CX 8/24 combined inserts for 40 A / 16 A / 10 A contacts follow a well known miniaturization trend in robotics: more power contacts and more auxiliary contacts in compact size connectors (77.27 and 57.27).

The connectors are ideal for applications requiring a large number of high/mid power connections (40 A CX series and 16 A CC series crimp contacts) and a large number of signals and auxiliary circuits (10 A CD series crimp contacts).

Product range

- > **CX 9/42** – 9 poles (40 A – 690 V) + 42 poles (10 A – 230 / 400 V) + ⊕ – size 77.27
- > **CX 6/36** – 6 poles (40 A – 690 V) + 36 poles (10 A – 230 / 400 V) + ⊕ – size 77.27
- > **CX 8/24** – 8 poles (16 A – 230 / 400 V) + 24 poles (10 A – 160 V) + ⊕ – size 57.27

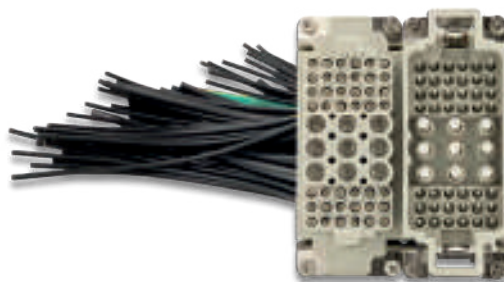
KEY FEATURES

- > EN 61984 ratings:
 - **40 A 690 V 8 kV 3** (core “high power” portion, 9 contact positions)
 - **10 A 250 V 4 kV 3** (peripheral “mid power/auxiliary” portions, 24 + 18 = 42 contact positions)
- > Lower and Upper Limiting Temperatures (LLT ... ULT): -40 °C ... +125 °C
- > Suitable for removable crimp contacts:
 - series CX up to size 6.0 (6 mm² / 10 AWG)
 - series CD up to size 2.5 (2,5 mm² / 14 AWG)

CX 9/42 connectors overview

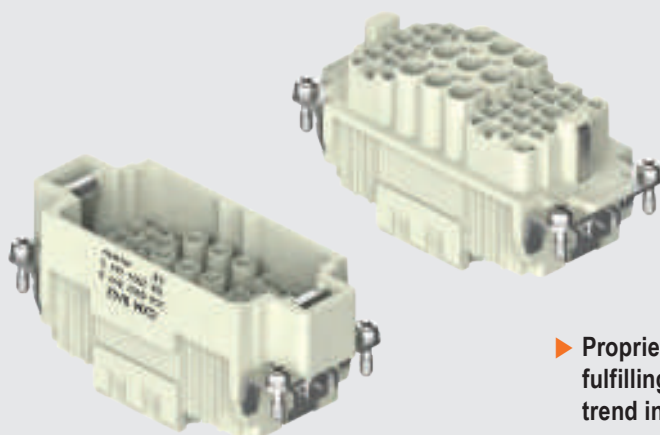
The **CX 9/42** insert (ILME proprietary design) features nine 40 A power contacts and additional 18 + 24 auxiliary 10 A poles for mid-power and signal connections.

It covers up to three 3Φ AC motors (3 axes with high-power motion control system) and 24 + 18 = 42 poles in peripheral mid-power/auxiliaries sections, to cover e.g. 4 additional motion control axes with 12 of the 18-pole portion, and the remaining 30 contacts serving auxiliary and signal contacts (I/O, solenoids, etc.).



FOCUS

Inserts' technology



- ▶ Proprietary design fulfilling miniaturization trend in robotics: more power contacts and more auxiliary contacts in smaller size

CX 9/42

40 A 690 V / 10 A 250 V

size **77.27**
9 / 42 poles + ⊕

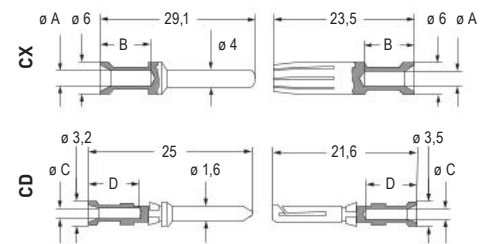
Crimp connection

EN 61984 rating	40 A 690 V 8 kV 3
	10 A 250 V 4 kV 3
Rated voltage (UL / CSA)	600 V
Insulation resistance	≥ 10 GΩ
Contact resistance	40 A (9 poles) ≤ 0,3 mΩ
	10 A (42 poles) ≤ 3 mΩ
Ambient temperature limit	-40 °C ... +125 °C
Mechanical life (cycles)	≥ 500



ILME US ECBT2.E115072 | ECBT8.E115072

Item	Description	Part No.	Dimension
	Male inserts for male contacts Without contacts (to be ordered separately)	CXM 9/42	
	Female inserts for female contacts Without contacts (to be ordered separately)	CXF 9/42	
	40 A crimp contacts section (mm ²) section (AWG)	Male	Female
	1,5 16	CXMA 1.5	CXFA 1.5
	2,5 14	CXMA 2.5	CXFA 2.5
	4 12	CXMA 4.0	CXFA 4.0
	6 10	CXMA 6.0	CXFA 6.0
	10 A crimp contacts section (mm ²) section (AWG)	Male	Female
	0,14-0,37 26-22	CDMA 0.3	CDFA 0.3
	0,5 20	CDMA 0.5	CDFA 0.5
	0,75 18	CDMA 0.7	CDFA 0.7
	1 18	CDMA 1.0	CDFA 1.0
	1,5 16	CDMA 1.5	CDFA 1.5
	2,5 14	CDMA 2.5	CDFA 2.5
	0,14-0,37 26-22	CDMD 0.3	CDFD 0.3
	0,5 20	CDMD 0.5	CDFD 0.5
	0,75 18	CDMD 0.7	CDFD 0.7
	1 18	CDMD 1.0	CDFD 1.0
	1,5 16	CDMD 1.5	CDFD 1.5
	2,5 14	CDMD 2.5	CDFD 2.5



Wiring information, CX and CD contacts

conductor section (mm ²)	conductor slot ø A (mm)	stripping length B (mm)	conductor section (mm ²)	conductor slot ø C (mm)	stripping length D (mm)
1,5	1,8	9	0,14-0,37	0,9	8
2,5	2,2	9	0,5	1,1	8
4	2,85	9,6	0,75	1,3	8
6	3,5	9,6	1,0	1,45	8
-	-	-	1,5	1,8	8
-	-	-	2,5	2,2	6

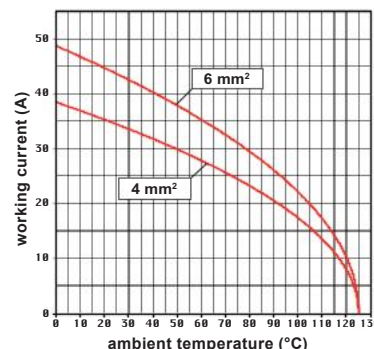
Wire diameter: up to 5,3 mm (CX series); up to 3,8 mm (CD series).
For basic or high thickness gold plating, please refer to page [E.16](#).
It is recommended to use the crimping tools and removal tools homologated by ILME (please see page [E.23](#)).

Materials

Insert	polycarbonate (PC)
UL 94 flame rating	V-0
Colour	pebble grey, RAL 7032
Contacts	copper alloy, silver ● and gold ● plated

Enclosures size 77.27

Pages	
Heavy-Duty Applications	
Metallic with C-TYPE lever	E.62-69
Metallic with IL-BRID lever	E.96-99 , 106
Metallic with JEI®-P lever	E.115-116 , 119
Metallic with V-TYPE IP67 lever	E.126 , 132-133
Thermoplastic T-TYPE	E.230-231 , 234-235
Aggressive Environments	
Metallic IP68 high protection	E.146-147
Metallic W-TYPE	E.158-159 , 164
Metallic E-Xtreme®	E.178-179 , 186-187 , 196
Thermoplastic T-TYPE/W	E.230-231 , 234-235
Specialized Applications	
EMC (Electromagnetic Shielding)	E.212-213 , 218
Hygienic series for food and beverage	E.246 , 248
Standard applications with Central lever	E.258-259
BIG Enclosures for multiple cable entries	E.270 , 276-277
COB system for switch cabinet	E.286-289
Light and Sound applications with JEI®-P lever	E.300-301



CX 9/42 inserts max. current load derating diagram

CX 6/36

40 A 690 V / 10 A 160 V

size **77.27**
6 / 36 poles + ⊕

Crimp connection

EN 61984 rating	10 A 160 V 2,5 kV 3 / 10 A 250 V 4 kV 2	40 A 690 V 8 kV 3
Rated voltage (UL / CSA)	600 V	
Insulation resistance	≥ 10 GΩ	
Contact resistance	40 A (6 poles)	≤ 0,3 mΩ
	10 A (36 poles)	≤ 1 mΩ
Ambient temperature limit	-40 °C ... +125 °C	
Mechanical life (cycles)	≥ 500	



ILME ECBT2.E115072 | ECBT8.E115072

Item	Description	Part No.	Dimension
	Male inserts for male contacts Without contacts (to be ordered separately)	CXM 6/36	

	Female inserts for female contacts Without contacts (to be ordered separately)	CXF 6/36	
--	--	--------------------------	--

	40 A crimp contacts	10 A crimp contacts	Male	Female	
	section (mm ²) section (AWG) 1,5 16 2,5 14 4 12 6 10	section (mm ²) section (AWG) 0,14-0,37 26-22 0,5 20 0,75 18 1 18 1,5 16 2,5 14	silver	CXMA 1.5 CXFA 1.5 CXMA 2.5 CXFA 2.5 CXMA 4.0 CXFA 4.0 CXMA 6.0 CXFA 6.0	
			silver	CDMA 0.3 CDFA 0.3 CDMA 0.5 CDFA 0.5 CDMA 0.7 CDFA 0.7 CDMA 1.0 CDFA 1.0 CDMA 1.5 CDFA 1.5 CDMA 2.5 CDFA 2.5	
			gold	CDMD 0.3 CDFD 0.3 CDMD 0.5 CDFD 0.5 CDMD 0.7 CDFD 0.7 CDMD 1.0 CDFD 1.0 CDMD 1.5 CDFD 1.5 CDMD 2.5 CDFD 2.5	

Wiring information, CX and CD contacts

conductor section (mm ²)	conductor slot ø A (mm)	stripping length B (mm)	conductor section (mm ²)	conductor slot ø C (mm)	stripping length D (mm)
1,5	1,8	9	0,14-0,37	0,9	8
2,5	2,2	9	0,5	1,1	8
4	2,85	9,6	0,75	1,3	8
6	3,5	9,6	1,0	1,45	8
-	-	-	1,5	1,8	8
-	-	-	2,5	2,2	6

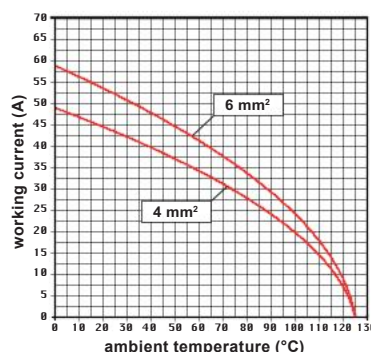
Wire diameter: up to 5,3 mm (CX series); up to 3,8 mm (CD series).
For basic or high thickness gold plating, please refer to page [E.14](#).

It is recommended to use the crimping tools and removal tools homologated by ILME (please see page [E.23](#)).

Materials	
Insert	polycarbonate (PC)
UL 94 flame rating	V-0
Colour	pebble grey, RAL 7032
Contacts	copper alloy, silver ● and gold ● plated

CIF 2.4
PCB adapter
Page [D.14](#)

Enclosures size 77.27	Pages
Heavy-Duty Applications	
Metallic with C-TYPE lever	E.62-69
Metallic with IL-BRID lever	E.96-99 I.06
Metallic with JEI®-P lever	E.115-116 I.19
Metallic with V-TYPE IP67 lever	E.126 I.32-133
Thermoplastic T-TYPE	E.230-231 I.34-235
Aggressive Environments	
Metallic IP68 high protection	E.146-147
Metallic W-TYPE	E.158-159 I.64
Metallic E-Xtreme®	E.178-179 I.86-187 I.96
Thermoplastic T-TYPE/W	E.230-231 I.34-235
Specialized Applications	
EMC (Electromagnetic Shielding)	E.212-213 I.218
Hygienic series for food and beverage	E.246 I.248
Standard applications with Central lever	E.258-259
BIG Enclosures for multiple cable entries	E.270 I.276-277
COB system for switch cabinet	E.286-289
Light and Sound applications with JEI®-P lever	E.300-301



CX 6/36 inserts max. current load derating diagram

CX 8/24

16 A 230/400 V / 10 A 160 V


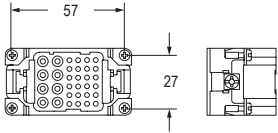

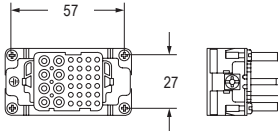
size **57.27**
8 / 24 poles + ⊕

Crimp connection

EN 61984 rating	16 A 230 / 400 V 4 kV 3 / 16 A 400 V 4 kV 2
	10 A 160 V 2,5 kV 3 / 10 A 250 V 4 kV 2
Rated voltage (UL / CSA)	600 V
Insulation resistance	≥ 10 GΩ
Contact resistance	16 A (8 poles) ≤ 1 mΩ
	10 A (24 poles) ≤ 3 mΩ
Ambient temperature limit	-40 °C ... +125 °C
Mechanical life (cycles)	≥ 500




CALUS ECBT2.E115072 | ECBT8.E115072

Item	Description	Part No.	Dimension
	Male inserts for male contacts Without contacts (to be ordered separately)	CXM 8/24	
	Female inserts for female contacts Without contacts (to be ordered separately)	CXF 8/24	

Materials

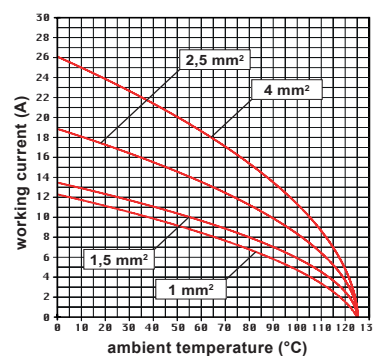
Insert	polycarbonate (PC)
UL 94 flame rating	V-0
Colour	pebble grey, RAL 7032



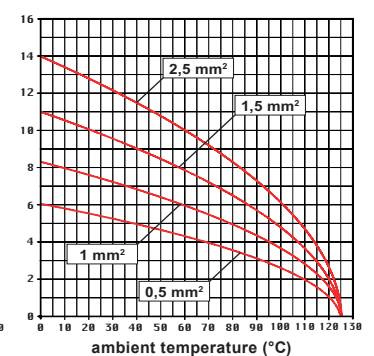
CIF 2.4
PCB adapter
Page [D.14](#)

Enclosures size 57.27	Pages
Heavy-Duty Applications	
Metallic with C-TYPE lever	E.54-61
Metallic with IL-BRID lever	E.92-98, 105
Metallic with JEI®-P lever	E.113-114, 119
Metallic with V-TYPE IP67 lever	E.125, 130-131
Thermoplastic T-TYPE	E.228-229, 234-235
Aggressive Environments	
Metallic IP68 high protection	E.144-145
Metallic W-TYPE	E.156-157, 163
Metallic E-Xtreme®	E.176-177, 184-185, 195
Thermoplastic T-TYPE/W	E.228-229, 234-235
Specialized Applications	
EMC (Electromagnetic Shielding)	E.210-211, 217
Hygienic series for food and beverage	E.243, 248
Standard applications with Central lever	E.256-257
BIG Enclosures for multiple cable entries	E.269, 274-275
COB system for switch cabinet	E.286-289
Light and Sound applications with JEI®-P lever	E.298-299

CX 8/24 inserts max. current load derating diagram, power poles



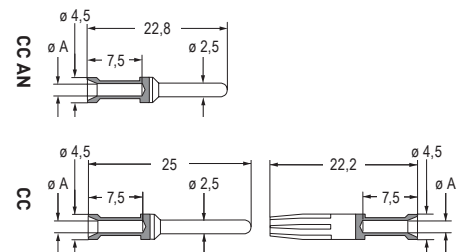
CX 8/24 inserts max. current load derating diagram, aux. poles



CX 8/24

16 A 230/400 V / 10 A 160 V

Item	Description	Part No.	Dimension									
	16 A advanced opening contacts section (mm ²) section (AWG) 0,5 20 0,75 18 1 18 1,5 16 2,5 14	Male CC 0.5 AN CC 0.7 AN CC 1.0 AN CC 1.5 AN CC 2.5 AN	Female									
					Male CCMA 0.3 CCMA 0.5 CCMA 0.7 CCMA 1.0 CCMA 1.5 CCMA 2.5 CCMA 3.0 CCMA 4.0	Female CCFA 0.3 CCFA 0.5 CCFA 0.7 CCFA 1.0 CCFA 1.5 CCFA 2.5 CCFA 3.0 CCFA 4.0						
								Male CCMD 0.3 CCMD 0.5 CCMD 0.7 CCMD 1.0 CCMD 1.5 CCMD 2.5 CCMD 3.0 CCMD 4.0	Female CCFD 0.3 CCFD 0.5 CCFD 0.7 CCFD 1.0 CCFD 1.5 CCFD 2.5 CCFD 3.0 CCFD 4.0			
											Male CDMA 0.3 CDMA 0.5 CDMA 0.7 CDMA 1.0 CDMA 1.5 CDMA 2.5	Female CDFA 0.3 CDFA 0.5 CDFA 0.7 CDFA 1.0 CDFA 1.5 CDFA 2.5
	Male CCMA 0.3 CCMA 0.5 CCMA 0.7 CCMA 1.0 CCMA 1.5 CCMA 2.5 CCMA 3.0 CCMA 4.0	Female CCFA 0.3 CCFA 0.5 CCFA 0.7 CCFA 1.0 CCFA 1.5 CCFA 2.5 CCFA 3.0 CCFA 4.0										



Wiring information, CC contacts

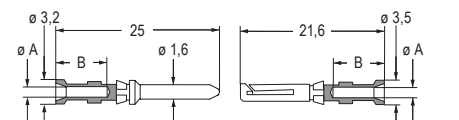
conductor section (mm ²)	conductor slot ø A (mm)	stripping length (mm)
0,14-0,37	0,9	7,5
0,5	1,1	7,5
0,75	1,3	7,5
1,0	1,45	7,5
1,5	1,8	7,5
2,5	2,2	7,5
3,0	2,55	7,5
4,0	2,85	7,5

Wire diameter: up to 4,7 mm.

For basic or high thickness gold plating, please refer to page F.13.

It is recommended to use the crimping tools and removal tools homologated by ILME (please see page F.23)

Item	Description	Part No.	Dimension									
	10 A crimp contacts section (mm ²) section (AWG) 0,14-0,37 26-22 0,5 20 0,75 18 1 18 1,5 16 2,5 14	Male CDMA 0.3 CDMA 0.5 CDMA 0.7 CDMA 1.0 CDMA 1.5 CDMA 2.5	Female CDFA 0.3 CDFA 0.5 CDFA 0.7 CDFA 1.0 CDFA 1.5 CDFA 2.5									
					Male CDMD 0.3 CDMD 0.5 CDMD 0.7 CDMD 1.0 CDMD 1.5 CDMD 2.5	Female CDFD 0.3 CDFD 0.5 CDFD 0.7 CDFD 1.0 CDFD 1.5 CDFD 2.5						
								Male CDMA 0.3 CDMA 0.5 CDMA 0.7 CDMA 1.0 CDMA 1.5 CDMA 2.5	Female CDFA 0.3 CDFA 0.5 CDFA 0.7 CDFA 1.0 CDFA 1.5 CDFA 2.5			
											Male CDMD 0.3 CDMD 0.5 CDMD 0.7 CDMD 1.0 CDMD 1.5 CDMD 2.5	Female CDFD 0.3 CDFD 0.5 CDFD 0.7 CDFD 1.0 CDFD 1.5 CDFD 2.5
	Male CDMD 0.3 CDMD 0.5 CDMD 0.7 CDMD 1.0 CDMD 1.5 CDMD 2.5	Female CDFD 0.3 CDFD 0.5 CDFD 0.7 CDFD 1.0 CDFD 1.5 CDFD 2.5										



Wiring information, CD contacts

conductor section (mm ²)	conductor slot ø A (mm)	stripping length B (mm)
0,14-0,37	0,9	8
0,5	1,1	8
0,75	1,3	8
1,0	1,45	8
1,5	1,8	8
2,5	2,2	6

Wire diameter: up to 3,8 mm.

For basic or high thickness gold plating, please refer to page F.16.

It is recommended to use the crimping tools and removal tools homologated by ILME (please see page F.23)

Materials

Contacts copper alloy, silver ● and gold ● plated

Connection information



Power and auxiliary poles simultaneously loaded

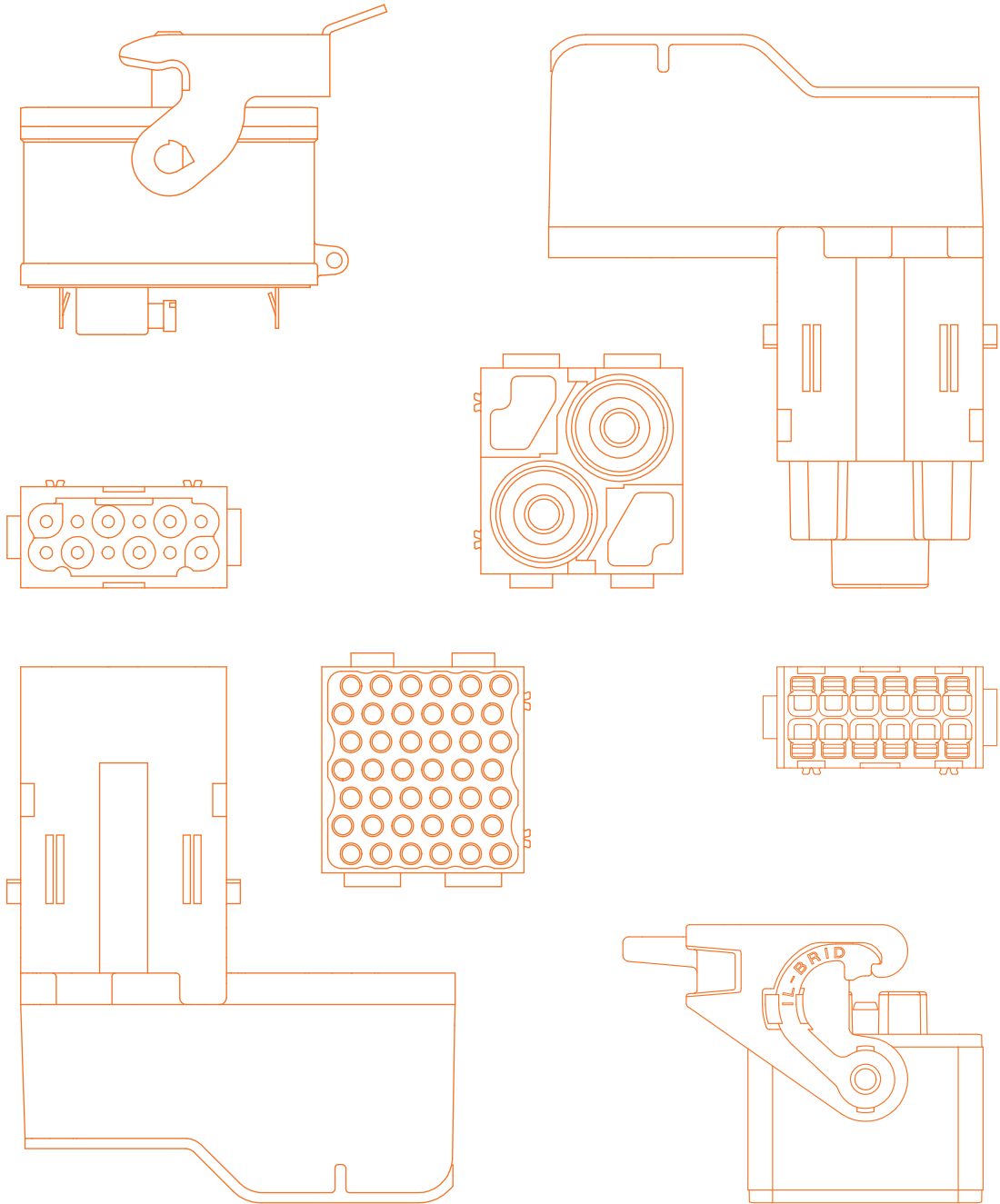
Power poles (mm ²)	Auxiliary poles (mm ²)
4,0	2,5
2,5	1,5
1,5	1,0
1,0	0,5

GENERAL CATALOGUE

MIXO modular inserts

Contents

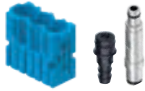

MIXO modular inserts	Introduction	C.4
Modules	Power	C.10
	- 300 A crimp / screw	C.12-15
	- 200 A crimp / screw	C.16-19
	- 100 A crimp	C.20-21
	- 70 A crimp	C.22
	PE modules for MIXO frames	C.24
	- 100 A crimp	C.26
	- 70 A screw	C.27
	Power & Signal	C.28
	- 40 A axial screw / crimp / tool-less AXYR®	C.30-38
	- 16 A crimp / tool-less SQUICH® - AXYR®	C.39-45
	- 10 A crimp / tool-less AXYR®	C.46-49
	- 4 A crimp	C.50-51
	High voltage	
	- 40 A crimp	C.52
	- 16 A crimp	C.53-54
	Shielded and BUS	C.56
	- 10 A crimp	C.58
	- 5 A crimp	C.59
	- 4 A crimp	C.60
	- 16 A crimp	C.62-63
	- 10 A crimp	C.62,64
	- 5 A crimp	C.62,65
	Data – RJ45 and HDMI	C.66
	RJ45 MIXO selection guide	C.68-69
	- RJ45 Cat. 6	C.70-73
	- RJ45 Cat. 5	C.74-76
	- USB	C.77
	- HDMI	C.78
	- D-SUB	C.79
	- Coaxial	C.80
	Data – Fibre Optic	C.82
	- Fibre Optic	C.81,84-85



GENERAL CATALOGUE

MIXO modular inserts

Contents

	Pneumatic	C.86
	- Plastic	C.88-89
	- Metal	C.90-93
	MIXO frames & accessories	
	- MIXO frames	C.94-95
	- CGT PE terminal adapters	C.96
	- Stainless-steel self-centring floating frames	C.97
	- MIXO thermoplastic docking frames	C.98-101
	- Dummy modules	C.102
	- Insulating MIXO holder and adapter for DIN rails	C.103
	MIXO ONE	C.104
	- MIXO ONE enclosures	C.106-107
	MIXO TWO	C.108
	- MIXO TWO enclosures	C.110-111

MIXO SERIES

GENERAL OVERVIEW

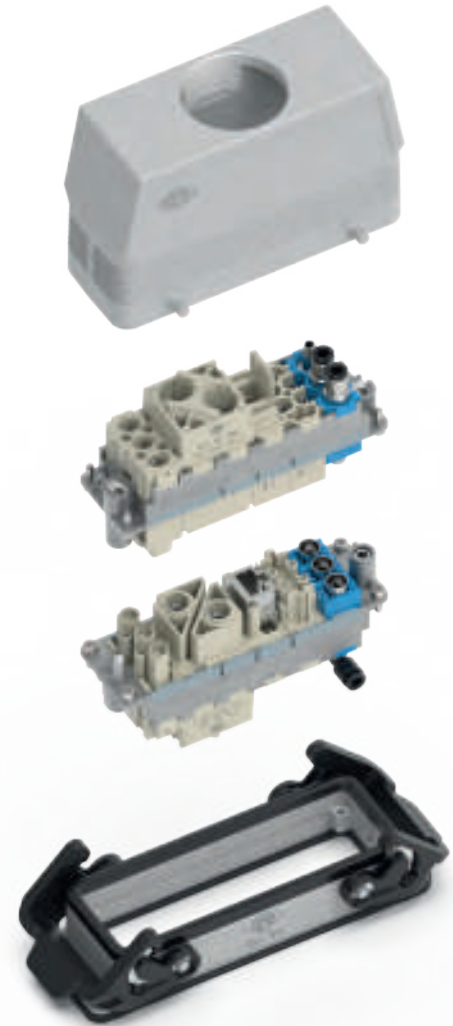


The MIXO series is a system of modular units for special applications that uses the traditional ILME enclosures. Each enclosure can house different types of connections such as: electric signals and contacts for the conduction of compressed air with pressure values of up to 10 bar.

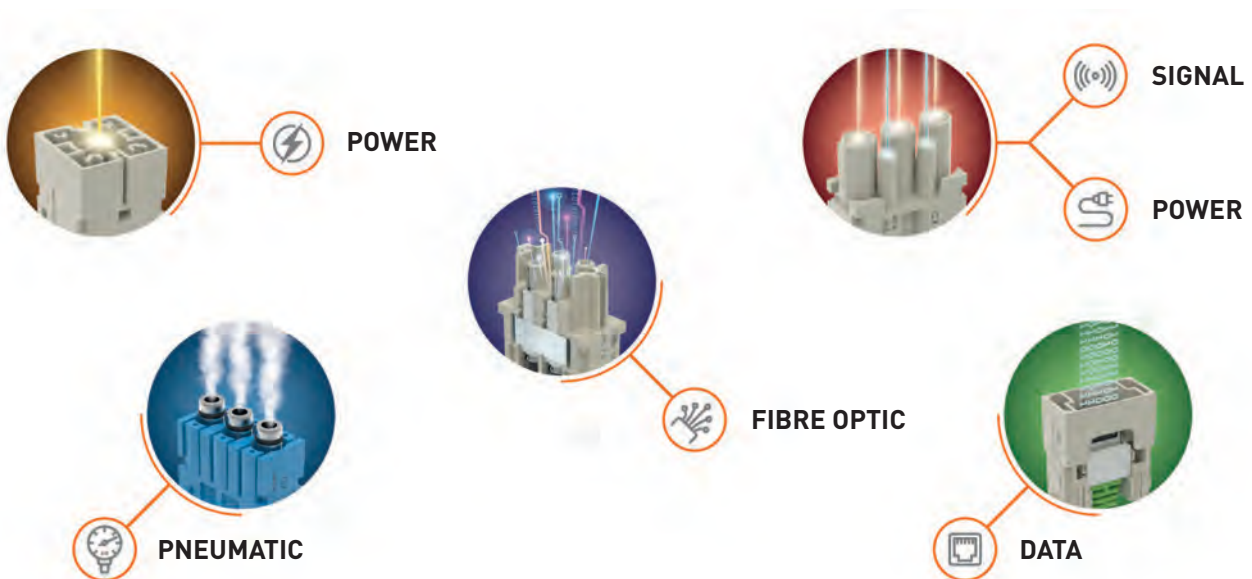
The inserts are arranged side-by-side to form a single compact block, which is inserted into **metal frames** and locked in place with special tabs, or into **thermoplastic frames** using a snap-in system.

The modular system makes it easy to access a series of contacts inserted in the frame (e.g., for substitution, check or the addition of signals with new inserts for needs not foreseen during the initial installation) without having to disassemble the entire connector.

ILME MIXO series of modular connectors is an open connector system that provides versatile configuration to the users' individual requirements, giving the **freedom to assemble a customized connector** from a wide range of modules for power electrical, data transmission, optical signals or air. The module range is continuously expanded, allowing new configurations to be realised.



□ The use of enclosures provides the possibility of innumerable applications.



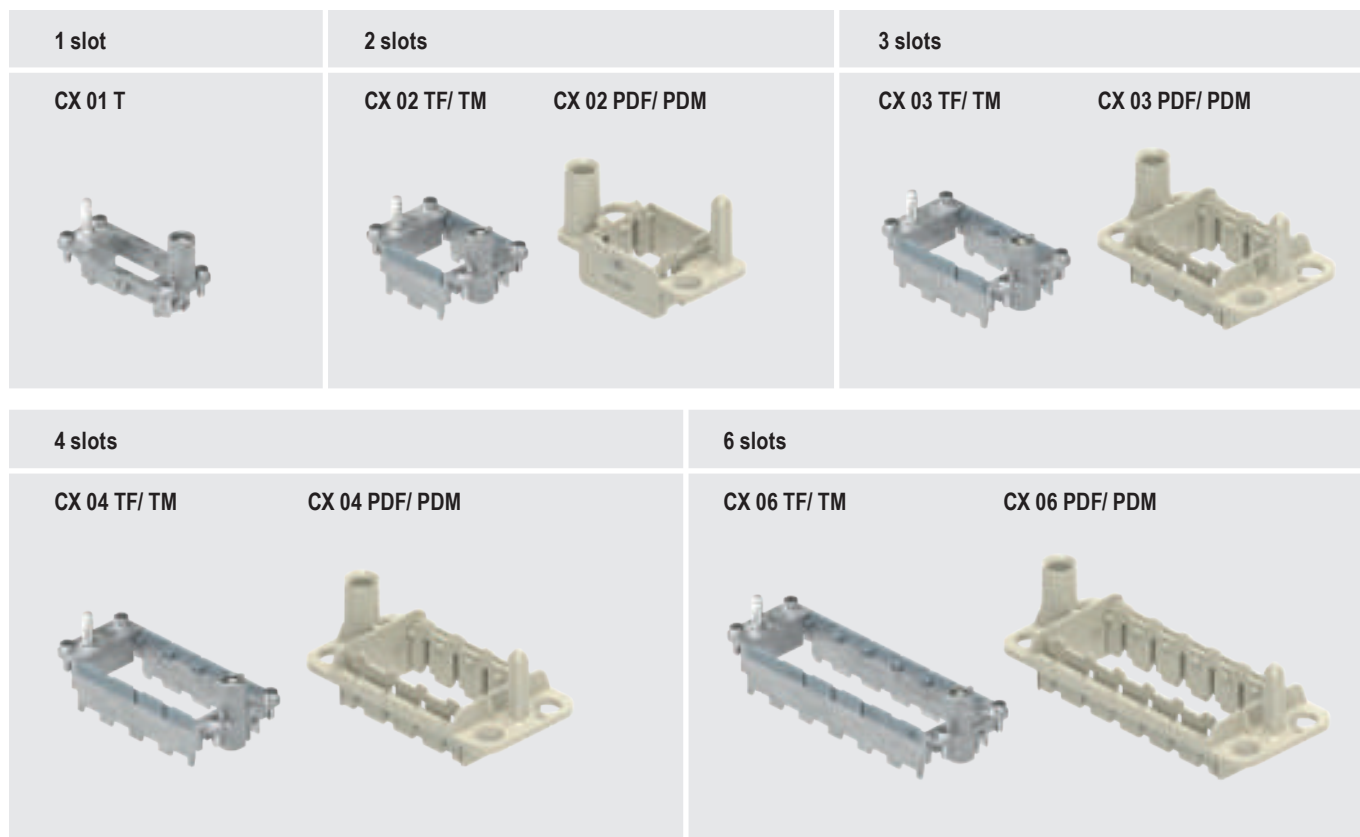
MIXO series modular units, once assembled as multi-module insert, can be directly mounted in both of the following **metal** and in the **thermoplastic docking frames**.

Metal frames	Enclosures size	Thermoplastic docking frames
CX 01 T	49.16	--
CX 02 TF/ CX 02 TM	44.27	CX 02 PDF/ PDM
CX 03 TF/ CX 03 TM	57.27	CX 03 PDF/ PDM
CX 04 TF/ CX 04 TM	77.27	CX 04 PDF/ PDM
CX 06 TF/ CX 06 TM	104.27	CX 06 PDF/ PDM
CX 04 TF/ CX 04 TM (×2)	77.62	--
CX 06 TF/ CX 06 TM (×2)	104.62	--

Possibility – to be verified case-by-case – to use the MIXO **HNM frames** (provided with special gold plated PE contacts) together with R series of crimp contacts and the relevant connector hoods and housings, to produce, where required, an **HNM connector** (High Number of Matings, up to 10 000 cycles of operation).

Single-sized modules, where specified, can also be installed directly inside **MIXO ONE** and **MIXO TWO** enclosures.

☞ NOTE: MIXO thermoplastic docking frames cannot be mounted inside enclosures.



In addition, the MIXO series can be used with the **COB series panel supports**:

Frames	COB panel supports part No.		
CX 02 TF/ CX 02 TM (fixed)	COB 06 BC	COB TCQ	
CX 02 TF/ CX 02 TM (mobile)	COB TSF	COB TSFS	COB 06 CMS
CX 03 TF/ CX 03 TM (fixed)	COB 10 BC	COB TCQ	
CX 03 TF/ CX 03 TM (mobile)	COB TSF	COB TSFS	COB 10 CMS
CX 04 TF/ CX 04 TM (fixed)	COB 16 BC	COB TCQ	
CX 04 TF/ CX 04 TM (mobile)	COB TSF	COB TSFS	COB 16 CMS
CX 06 TF/ CX 06 TM (fixed)	COB 24 BC	COB TCQ	
CX 06 TF/ CX 06 TM (mobile)	COB TSF	COB TSFS	COB 24 CMS



THE COMPLETE RANGE

Modules	Series	Contact type	Module type	Connection technology	Rated current (A) ⁽¹⁾	Rated voltage (V)	Number of frame slots
CX 01/01B 30F/M		main	electric	crimp	300	1000	2
CX 01/01B 30PEF/M		PE	electric	crimp	—	—	2
CX 01 30AF/M		main	electric	90° screw	300	1000	2
CX 01 30PEAF/M		PE	electric	90° screw	—	—	2
CX 01 YF/M		main	electric	crimp	200	1000	2
CX 01 YPEF/M		PE	electric	crimp	—	—	2
CX 01 YAF/M		main	electric	90° screw	200	1000	2
CX 01 YPEAF/M		PE	electric	90° screw	—	—	2
CX 01 GF/M		main	electric	crimp	100	830	1
CX 01 GPEF/M		PE	electric	crimp	—	—	1
CX 01 PEF/M		PE	electric	screw	—	—	1
CX 02 GF/M		main	electric	crimp	100	1000	2
CX 02 7F/M		main	electric	crimp	70	1000	1
CX 02 4AF/M		main	electric	axial screw	40	1000	1
CX 02 4BF/M		main	electric	axial screw	40	1000	1
CX 02 4F/M		main	electric	crimp	40	1000	1
CX 02 4YF/M		main	electric	AXYR® spring	40	1000	1
CX 03 4F/M		main	electric	crimp	40	400 / 690	1
CX 03 4YF/M		main	electric	AXYR® spring	40	690	1
CX 03 4BF/BM		main	electric	crimp	40	500	1
CX 3/4 XDF/M		main / auxiliary	electric	crimp	40 / 10	830	1
CX 04 XF/M		main	electric	crimp	40	830	1
CX 04 XYF/M		main	electric	AXYR® spring	40	830	1
CX 05 SHF/M		main	electric	SQUICH® spring	16	400	1
CX 06 CF/M		main	electric	crimp	16	500	1
CX 06P CF/M		main	electric	crimp	16	830	1
CX 06 CYF/M		main	electric	AXYR® spring	16	500	1
CX 08 CF/M		main	electric	crimp	16	400	1
CX 08 CYF/M		main	electric	AXYR® spring	16	400	1
CX 08 I6F/M		main + shield	electric	crimp	5	50	1
CX 08 I6GF/I6GM		main + shield	electric	crimp	5	50	1
RX 08 I6F/M	HNM	main + shield	electric	crimp	5	50	1
RX 08 I6GF/I6GM	HNM	main + shield	electric	crimp	5	50	1
CX 08 D5F/F2 M/M2		main + shield	electric	crimp	10	50	1
CX 08 D5GF/F2 GM/M2		main + shield	electric	crimp	10	50	1
RX 08 D5F/F2 M/M2	HNM	main + shield	electric	crimp	10	50	1
RX 08 D5GF/F2 GM/M2	HNM	main + shield	electric	crimp	10	50	1
CX 20 CF/M		main	electric	crimp	16	500	2
CX 12 DF/M		main / auxiliary	electric	crimp	10	250	1
CX 12 DYF/M		main / auxiliary	electric	AXYR® spring	10	250	1
CX 17 DF/M		main / auxiliary	electric	crimp	10	160	1
CX 42 DF/M		main / auxiliary	electric	crimp	10	150	2
CX 25 IBF/M		main / auxiliary	electric	crimp	4	50	1
CX 20S IF/M		main / auxiliary + shield	electric	crimp	4	32	1
CX 20S IGF/IGM		main / auxiliary + shield	electric	crimp	4	32	1
RX 20S IF/M	HNM	main / auxiliary + shield	electric	crimp	4	32	1
RX 20S IGF/IGM	HNM	main / auxiliary + shield	electric	crimp	4	32	1

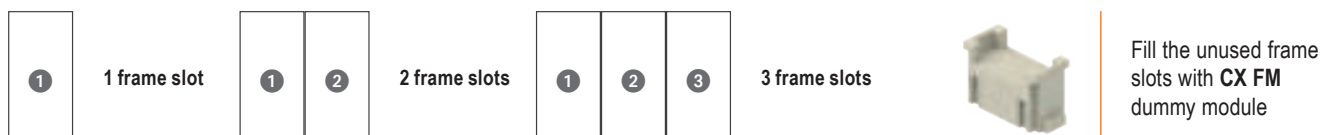
¹⁾ Please check the insert derating diagrams to establish the actual maximum operating current according to the ambient temperature.

Modules	Series	Contact type	Module type	Connection technology	Rated current (A) ⁽¹⁾	Rated voltage (V)	Number of frame slots
CX 36 IF/M		main / auxiliary	electric	crimp	4	32	①
CX 02 CHF/M		main	electric	crimp	16	2500	①
CX 02 HF/M		main	electric	crimp	16	5000	②
CX 02 4HF/M		main	electric	crimp	40	5000	②
CX 02 BF/M		seat for two shielded connectors (refer to CX 04 B, CX 01 B, CX 01 BC, CX 08 B)					
CX 01 BCF/M		main / auxiliary + shield	electric	crimp	16	50	—
CX 01 BF/M		main / auxiliary + shield	electric	crimp	10	50	—
CX 04 BF/M		main / auxiliary + shield	electric	crimp	10	50	—
CX 08 BF/M		main / auxiliary + shield	electric	crimp	5	50	—
CX 03 P		pneumatic plastic Ø 1,6 - 3,0 - 4,0 mm	air	—	—	—	①
CX 02 P		pneumatic plastic Ø 6,0 mm	air	—	—	—	①
CX 03 MP		pneumatic metal Ø 3,0 - 4,0 - 6,0 mm	air	—	—	—	①
CX 02 MPBF/M		pneumatic metal Ø 8,0 - 10,0 mm	air	—	—	—	②
CX FM		none (dummy module)	—	—	—	—	①
CX 01 J8F/M		RJ45	electric	crimp	—	—	①
CX 01 J8IM		RJ45	electric	IDC	—	—	①
CX 01 J8AIF/BIF/PIF		RJ45 + shield	electric	IDC	1	50	①
CX 01 J8UM		RJ45	electric	patch-cord	—	—	①
CX 01 JF/M		RJ45 + auxiliary	electric	crimp	10	250	②
CX 02 JF/M		RJ45 + auxiliary	electric	crimp	10	250	③
CX 01 UF/M		USB	electric	—	—	—	①
CX 01 9VF/M		D-SUB + shield	electric	crimp	5	50	①
CX 01 9VF2/M2		D-SUB + shield	electric	crimp	5	50	①
CX 01 9VTF		D-SUB + shield	electric	screw	5	50	①
CX 01 MIF/MIM		HDMI	electric	—	—	—	①
CX 04 LF/M		POF / MOST	optic	crimp	—	—	①
CX 04 RF/M		coaxial	electric	crimp	—	—	①
CX 06 LCF/M		LC fibre optic	optic	crimp / glue	—	—	①
CX 04 SCF/M		SC fibre optic	optic	crimp / glue	—	—	①

¹⁾ Please check the insert derating diagrams to establish the actual maximum operating current according to the ambient temperature.

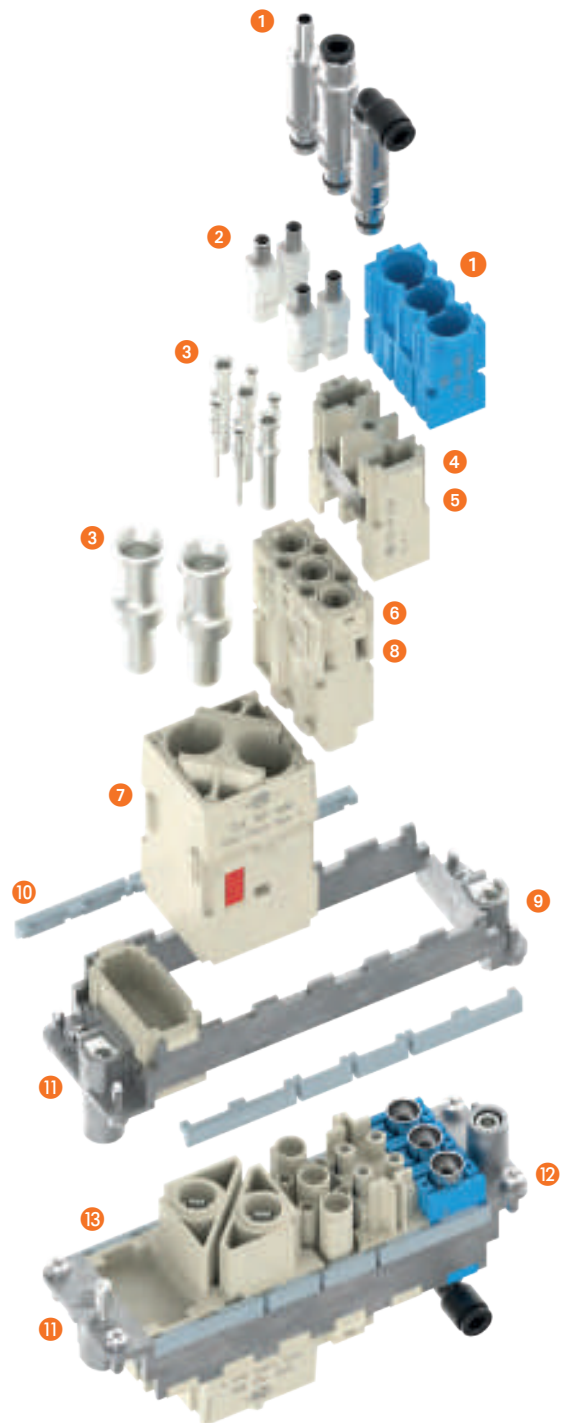
Calculate the number of frame slots taken up by the required inserts (1-, 2-, or 3-slot sized modular inserts) and select the correspondingly sized frame having the overall number of required slots (1-, 2-, 3-, 4-, and 6-slot metal frames, or the 2-, 3-, 4-, and 6-slot thermoplastic docking frames, see pages C.98-101).

Single-sized modules, where specified, can also be installed directly inside **MIXO ONE** and **MIXO TWO** enclosures.



TECHNICAL CHARACTERISTICS

- 1 Metal pneumatic contacts with hose barbs or quick fitting connection, available also in plastic with hose barbs connection.
- 2 Fibre optic contacts SC type.
- 3 Electric contacts in silver-plated or gold-plated brass with connections to the conductors via crimping, spring clamp or axial screw.
- 4 Modular inserts of single or multiple size with mutual slide locking system for forming the complete multi-module insert and metal frame locking tabs.
- 5 Inserts in self-extinguishing thermoplastic material, reinforced with glass fibre, UL 94V-0 approved, with a working temperature range of -40 °C to +125 °C (unless otherwise declared).
- 6 Inserts in conformance with the requirements of the EN 61984 standard and certified and marked with the UL, CSA (where applicable), CQC, DNV, BV, EAC (where applicable) marks.
- 7 Inserts with patented “dovetails” to prevent incorrect coupling.
- 8 Position of contacts identified with numbers or codes on both faces (mating and wiring) of every insert.
- 9 Male/female module carrier frames with obliged positioning and polarization, in die-cast zinc alloy.
- 10 Module locking tabs, may be split according to the number of modules used; they guarantee a perfect stability of the modules during wiring and coupling/uncoupling of the connectors.
- 11 Asymmetric protective earth contacts (two per frame) with wide contact surface, prevent incorrect coupling; when two or more identical connectors of the MIXO series are used, coding pins may prevent incorrect coupling.
- 12 Captive frame fastening screws, with anti-loosening spring washer.
- 13 Dummy module for unused frame slots.



ADVANTAGES

- ☑ Easy and user-friendly assembly of the complete multi-module insert before fixing it on the relevant suitably sized metal frame or thermoplastic docking frame;
- ☑ use of proprietary ILME technology providing each module with “dovetails” (lateral keys/keyways), for reciprocal locking of modules and overall assembly of the insert into rigid (non hinged) frames with snap-in locking tabs;
- ☑ faster and easier assembly compared with competitor solutions (easier handling of modules as a complete block than e.g. 6 independent parts);
- ☑ intermateability at “complete connector” (modules in frame) with other industry standard products;
- ☑ robust and long lasting prevailing crimp connection technology (largely preferred over screw type technology in high vibration and shock environments).

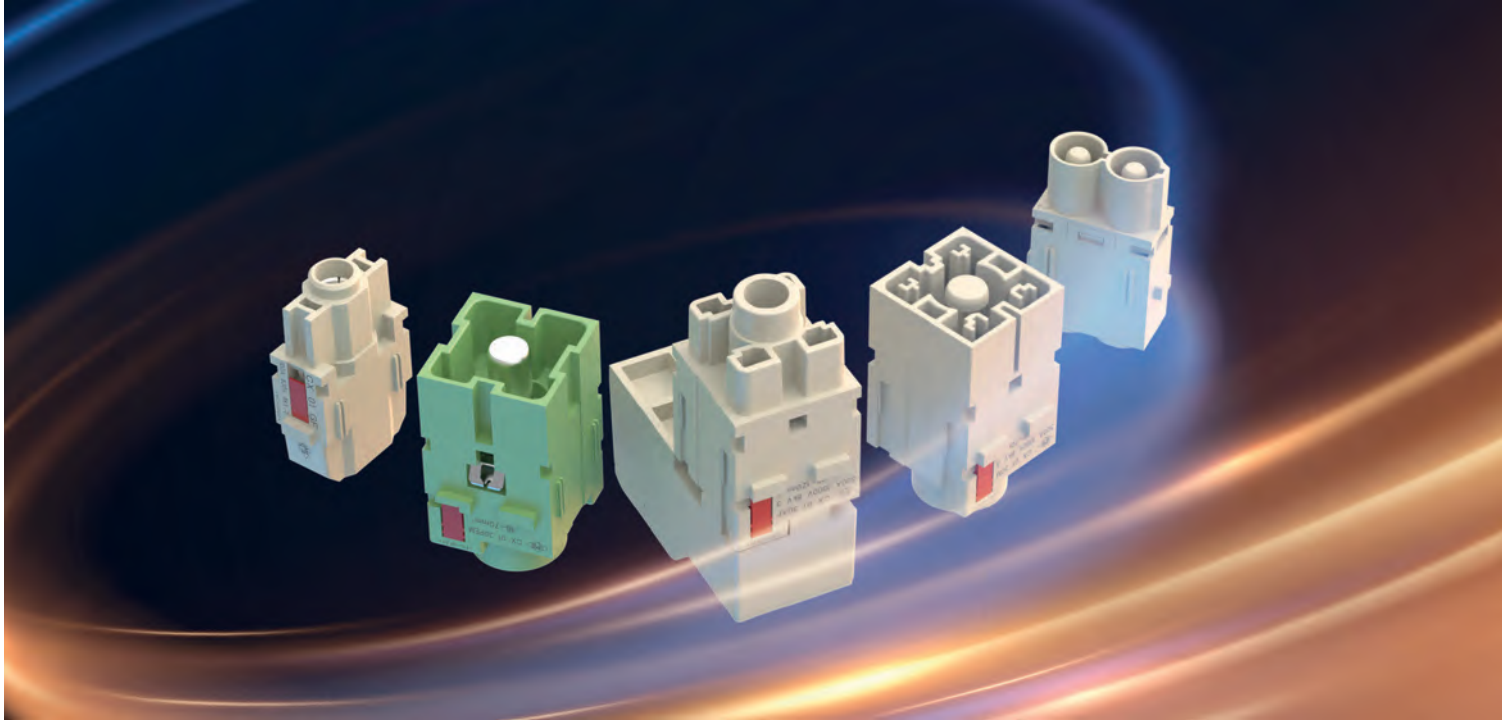


Watch our clip



MIXO SERIES AT A GLANCE

MIXO Power modules



The **MIXO modular system** offers a comprehensive and versatile product range, covering sensitive signal and data applications and power connections **up to 300 A**.

The requirement to provide a wiring solution for conductors with large wire cross-sections capable of withstanding high current loads, led to the design of the MIXO 300 A, CX 01 30 modules and complementary suitable crimp C30 series contacts.



Watch our clip

MIXO CX 01 /01B 30 modules

The MIXO 2-slot-sized modules for the 300 A C30 series crimp contacts are available in two sizes:

- > **01** (regular), for use with new series C30 crimp contacts of sizes 16, 25, 35, 50 and 70;
- > **01B** (large), for use with new series C30 crimp contacts of larger sizes 95 and 120.

The C30 contact series also includes protected male contacts, i.e., male contacts with insulating tips that provide finger-proof safety for the male connector modules.

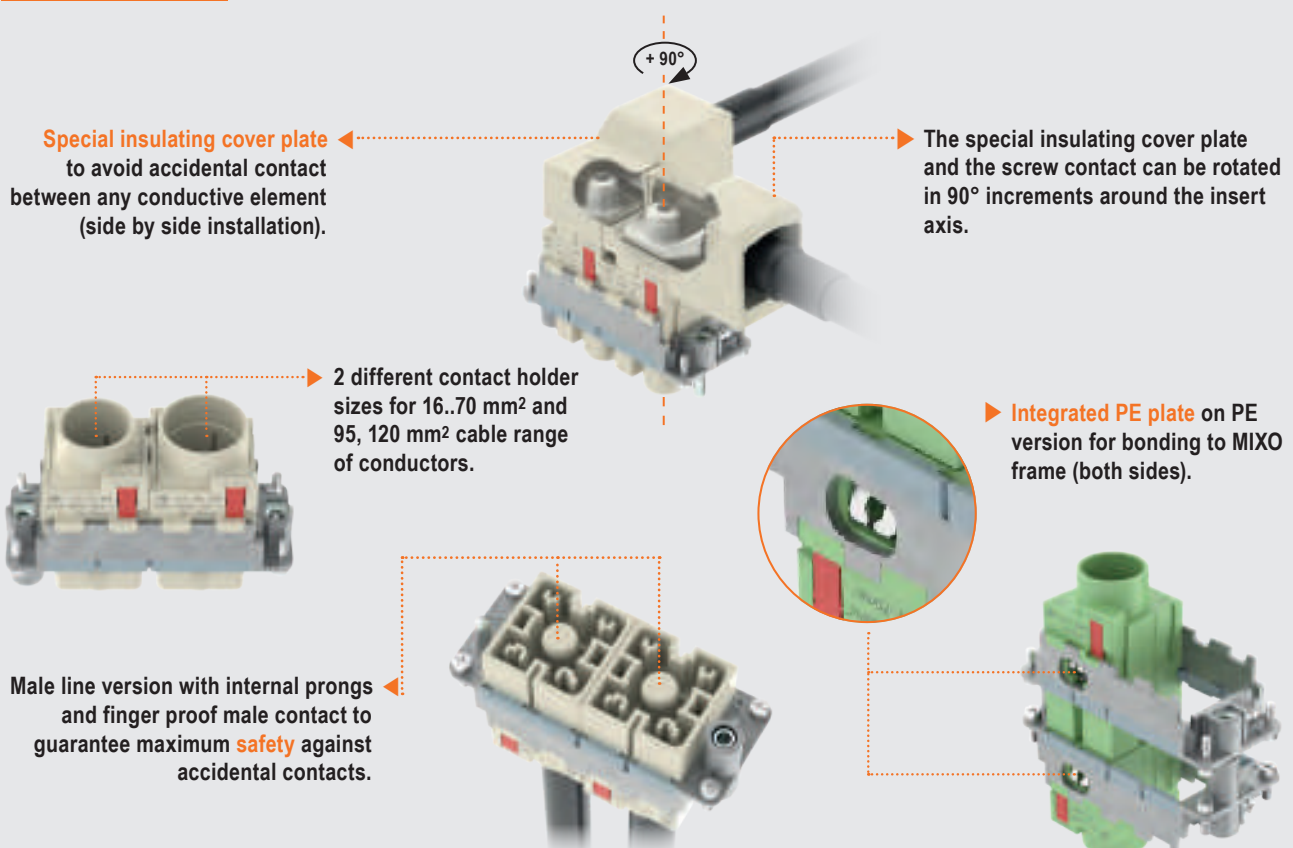
The two sizes cover different wiring ranges, each available in line (insulated) and PE versions.

MIXO CX 01 30A module

- > The MIXO **CX 01 30A line module** and **CX 01 30PEA PE module** are the solutions introduced by ILME to widen the potential of the MIXO high-current series, modules with the same compatible electrical rating and mating interface of the 300 A crimp versions but designed to minimize its space installation requirements.
- > The male and female contacts for the angled 300 A module allow the connection of DIN 46235 pre-insulated crimp cable lugs (using M8 TORX® T45 screw), available on the market in the dimension for wire cross-sectional areas of 10, 16, 25, 35, 50, 70, 95 and 120 mm².
- > To maintain proper electrical insulation, ILME designed a **special insulating cover plate**. This plate avoids accidental contact between cable lugs of adjacent modules and saves the nominal voltage rating of 1000 V, and 1300 V_{DC} planned for the 300 A modules.

FOCUS

Insert features



CX 01 30 / CX 01B 30

300 A 1000 V / 1300 V_{DC}

size **2 modules**

1 pole


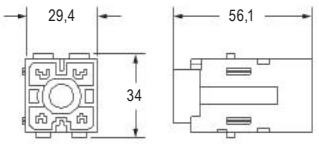

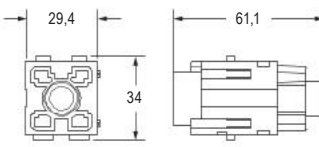
Crimp connection

EN 61984 rating	300 A 1000 V 8 kV 3 – 1300 V _{DC}
	300 A 920 / 1600 V 8 kV 2
Rated voltage (UL / CSA)	600 V
Insulation resistance	≥ 10 GΩ
Contact resistance	≤ 0,2 mΩ
Ambient temperature limit	-40 °C ... +125 °C
Mechanical life (cycles)	≥ 500

CE UK (pending: EAC)

(pending: CQC, DNV and BV)

(pending: cURus)

Item	Description	Part No.	Dimension
	Male insert for male contact 16..70 mm ²	CX 01 30M	
	Male insert for male contacts 95 and 120 mm ²	CX 01B 30M	
	Without contacts (to be ordered separately)		
	Female insert for female contacts 16..70 mm ²	CX 01 30F	
	Female inserts for female contacts 95 and 120 mm ²	CX 01B 30F	
	Without contacts (to be ordered separately)		

300 A crimp contacts	section (mm ²)		section (AWG)		Male	Female		
		16	25	35	50	70	95	120
	6	4	2	1	2/0	3/0	4/0	
					C30MA 16 P C30MA 25 P C30MA 35 P C30MA 50 P C30MA 70 P C30MA 95 P C30MA 120 P	C30FA 16 C30FA 25 C30FA 35 C30FA 50 C30FA 70 C30FA 95 C30FA 120		

Wiring information, C30 contacts


conductor section (mm ²)	conductor slot ø A (mm)	ø B (mm)	C (mm)	D (mm)	conductor stripping length (mm)
16	5,5	18	42,7	39,1	19
25	7	18	42,7	39,1	19
35	8,2	18	43,7	40,1	20
50	10	18	49,2	45,6	22,5
70	11,5	18	49,2	45,6	22,5
95	13,5	21	49,2	45,6	22,5
120	15,5	21	49,2	45,6	22,5

Wire diameter:
 - up to 18,5 mm for size 01 modules (up to 70 mm²/AWG 2/0);
 - up to 22 mm for size 01B modules (up to 120 mm²/AWG 4/0).

It is recommended to use the crimping tools and removal tools homologated by ILME (please see page [F.23](#))

Materials

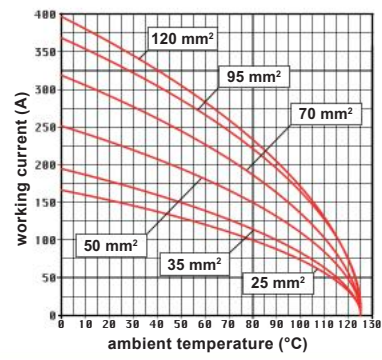
Insert	polycarbonate (PC)
UL 94 flame rating	V-0
Colour	pebble grey, RAL 7032
Contacts	copper alloy, silver ● plated



CGT..
 PE wire terminal adapter
 Page [C.96](#)

Accessories

Accessories	Pages
MIXO Frames	
Metal frames for modular units	C.98
Thermoplastic docking frames	C.98-101



CX 01/01B 30 inserts max. current load derating diagram

Can be used in bulkhead mounting housings or in high construction housings or in high construction hoods.

CX 01 30PE / CX 01B 30PE

size **2 modules**
1 PE pole

Crimp connection

EN 61984 rating	—
Rated voltage (UL / CSA)	—
Insulation resistance	—
Contact resistance	≤ 0,2 mΩ
Ambient temperature limit	-40 °C ... +125 °C
Mechanical life (cycles)	≥ 500

CE UK (pending: EAC)

(pending: CQC, DNV and BV)

(pending: cURus)

Item	Description	Part No.	Dimension																																																
	PE male insert for male contacts 16..70 mm ²	CX 01 30PEM																																																	
	PE male insert for male contacts 95 and 120 mm ²	CX 01B 30PEM																																																	
	Without contacts (to be ordered separately)																																																		
	PE female insert for male contacts 16..70 mm ²	CX 01 30PEF																																																	
	PE female insert for male contacts 95 and 120 mm ²	CX 01B 30PEF																																																	
	Without contacts (to be ordered separately)																																																		
	300 A crimp contacts	Male	Female																																																
	<table border="1"> <thead> <tr> <th>section (mm²)</th> <th>section (AWG)</th> </tr> </thead> <tbody> <tr><td>16</td><td>6</td></tr> <tr><td>25</td><td>4</td></tr> <tr><td>35</td><td>2</td></tr> <tr><td>50</td><td>1</td></tr> <tr><td>70</td><td>2/0</td></tr> <tr><td>95</td><td>3/0</td></tr> <tr><td>120</td><td>4/0</td></tr> </tbody> </table>	section (mm ²)	section (AWG)	16	6	25	4	35	2	50	1	70	2/0	95	3/0	120	4/0	<table border="1"> <thead> <tr> <th>Male</th> <th>Female</th> </tr> </thead> <tbody> <tr><td>C30MA 16</td><td>C30FA 16</td></tr> <tr><td>C30MA 25</td><td>C30FA 25</td></tr> <tr><td>C30MA 35</td><td>C30FA 35</td></tr> <tr><td>C30MA 50</td><td>C30FA 50</td></tr> <tr><td>C30MA 70</td><td>C30FA 70</td></tr> <tr><td>C30MA 95</td><td>C30FA 95</td></tr> <tr><td>C30MA 120</td><td>C30FA 120</td></tr> </tbody> </table>	Male	Female	C30MA 16	C30FA 16	C30MA 25	C30FA 25	C30MA 35	C30FA 35	C30MA 50	C30FA 50	C30MA 70	C30FA 70	C30MA 95	C30FA 95	C30MA 120	C30FA 120																	
section (mm ²)	section (AWG)																																																		
16	6																																																		
25	4																																																		
35	2																																																		
50	1																																																		
70	2/0																																																		
95	3/0																																																		
120	4/0																																																		
Male	Female																																																		
C30MA 16	C30FA 16																																																		
C30MA 25	C30FA 25																																																		
C30MA 35	C30FA 35																																																		
C30MA 50	C30FA 50																																																		
C30MA 70	C30FA 70																																																		
C30MA 95	C30FA 95																																																		
C30MA 120	C30FA 120																																																		
			<p>Wiring information, C30 contacts</p> <table border="1"> <thead> <tr> <th>conductor section (mm²)</th> <th>conductor slot ø A (mm)</th> <th>ø B (mm)</th> <th>C (mm)</th> <th>D (mm)</th> <th>conductor stripping length (mm)</th> </tr> </thead> <tbody> <tr><td>16</td><td>5,5</td><td>18</td><td>41,2</td><td>39,1</td><td>19</td></tr> <tr><td>25</td><td>7</td><td>18</td><td>41,2</td><td>39,1</td><td>19</td></tr> <tr><td>35</td><td>8,2</td><td>18</td><td>42,2</td><td>40,1</td><td>20</td></tr> <tr><td>50</td><td>10</td><td>18</td><td>47,7</td><td>45,6</td><td>22,5</td></tr> <tr><td>70</td><td>11,5</td><td>18</td><td>47,7</td><td>45,6</td><td>22,5</td></tr> <tr><td>95</td><td>13,5</td><td>21</td><td>47,7</td><td>45,6</td><td>22,5</td></tr> <tr><td>120</td><td>15,5</td><td>21</td><td>47,7</td><td>45,6</td><td>22,5</td></tr> </tbody> </table> <p>Wire diameter: - up to 18,5 mm for size 01 modules (up to 70 mm²/AWG 2/0); - up to 22 mm for size 01B modules (up to 120 mm²/AWG 4/0).</p> <p>It is recommended to use the crimping tools and removal tools homologated by ILME (please see page E.23)</p>	conductor section (mm ²)	conductor slot ø A (mm)	ø B (mm)	C (mm)	D (mm)	conductor stripping length (mm)	16	5,5	18	41,2	39,1	19	25	7	18	41,2	39,1	19	35	8,2	18	42,2	40,1	20	50	10	18	47,7	45,6	22,5	70	11,5	18	47,7	45,6	22,5	95	13,5	21	47,7	45,6	22,5	120	15,5	21	47,7	45,6	22,5
conductor section (mm ²)	conductor slot ø A (mm)	ø B (mm)	C (mm)	D (mm)	conductor stripping length (mm)																																														
16	5,5	18	41,2	39,1	19																																														
25	7	18	41,2	39,1	19																																														
35	8,2	18	42,2	40,1	20																																														
50	10	18	47,7	45,6	22,5																																														
70	11,5	18	47,7	45,6	22,5																																														
95	13,5	21	47,7	45,6	22,5																																														
120	15,5	21	47,7	45,6	22,5																																														

Materials

Insert	polycarbonate (PC)
UL 94 flame rating	V-0
Colour	green, RAL 6011
Contacts	copper alloy, silver ● plated



CGT..

PE wire terminal adapter

Page [C.96](#)

Accessories

Pages

MIXO Frames

Metal frames for modular units	C.95
Thermoplastic docking frames	C.98-101

CX 01 30A

300 A 1000 V / 1300 V_{DC}

size **2 modules**

1 pole


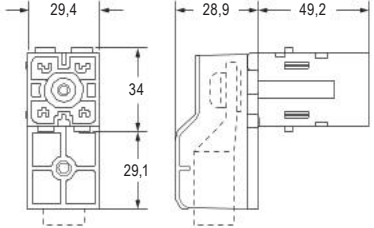

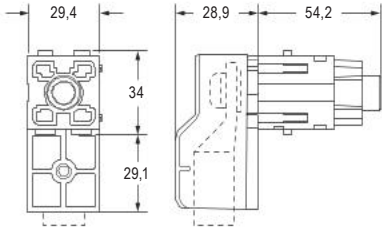
Screw connection

EN 61984 rating	300 A 1000 V 8 kV 3 – 1300 V _{DC}
Rated voltage (UL / CSA)	600 V
Insulation resistance	≥ 10 GΩ
Contact resistance	≤ 3 mΩ
Ambient temperature limit	-40 °C ... +125 °C
Mechanical life (cycles)	≥ 500

CE UK (pending: EAC)

(pending: CQC, DNV and BV)

(pending: cURus)

Item	Description	Part No.	Dimension
	Male inserts with male contact Screw terminal connection - 90° angled Supplied with heat-shrinking insulating tube, to be used with tubular cable lug (not supplied)	CX 01 30AM	
	Female inserts with female contact Screw terminal connection - 90° angled Supplied with heat-shrinking insulating tube, to be used with tubular cable lug (not supplied)	CX 01 30AF	

Materials

Insert	polycarbonate (PC)
UL 94 flame rating	V-0
Colour	pebble grey, RAL 7032
Contacts	built-in, copper alloy, silver ● plated

Wiring information

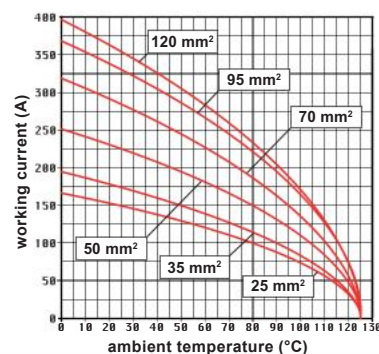
Wires cross sectional area	16 mm ² - 120 mm ² (AWG 6-4/0)
Terminal screw	M8 TORX® T45
Terminal screw torque	10 Nm (88.5 lb.in)



CGT..
PE wire terminal adapter
Page [C.96](#)

Accessories

Accessories	Pages
MIXO Frames	
Metal frames for modular units	C.98
Thermoplastic docking frames	C.98-101



CX 01 30A inserts max. current load derating diagram

Can be used in bulkhead mounting housings only.

CX 01 30PEA

size **2 modules**
1 PE pole


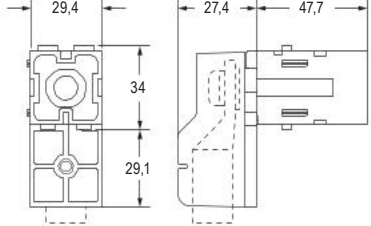

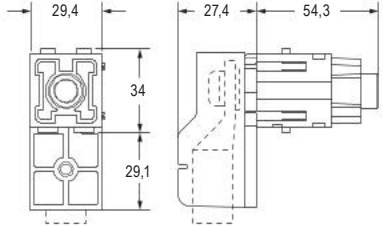
Screw connection

EN 61984 rating	—
Rated voltage (UL / CSA)	—
Insulation resistance	—
Contact resistance	≤ 3 mΩ
Ambient temperature limit	-40 °C ... +125 °C
Mechanical life (cycles)	≥ 500

CE UK (pending: EAC)

(pending: CQC, DNV and BV)

(pending: cURus)

Item	Description	Part No.	Dimension
	PE male inserts with male contact Screw terminal connection - 90° angled	CX 01 30PEAM	
	PE female inserts with female contact Screw terminal connection - 90° angled	CX 01 30PEAF	

Materials		Wiring information	
Insert	polycarbonate (PC)	Wires cross sectional area	16 mm ² - 120 mm ² (AWG 6-4/0)
UL 94 flame rating	V-0	Terminal screw	M8 TORX® T45
Colour	green, RAL 6011	Terminal screw torque	10 Nm (88.5 lb.in)
Contacts	built-in, copper alloy, silver ● plated		



CGT..
PE wire terminal adapter
Page [C.96](#)

Accessories	Pages
MIXO Frames	
Metal frames for modular units	C.96
Thermoplastic docking frames	C.98-101

Can be used in bulkhead mounting housings only.

CX 01 Y

200 A 1000 V

size **2 modules**
1 pole


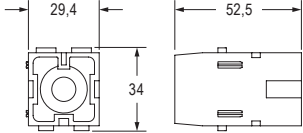

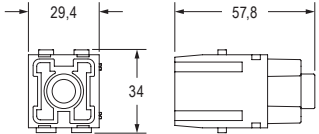
Crimp connection

EN 61984 rating	200 A 1000 V 8 kV 3
	200 A 920 / 1600 V 8 kV 2
Rated voltage (UL / CSA)	600 V
Insulation resistance	≥ 10 GΩ
Contact resistance	≤ 0,2 mΩ
Ambient temperature limit	-40 °C ... +125 °C
Mechanical life (cycles)	≥ 500

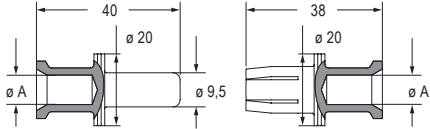
CE UK CA (pending: EAC)

SP DNV (pending: CQC)

CBUS ECBT2.E115072 | ECBT8.E115072
PVVA2.E506437 | PVVA8.E506437

Item	Description	Part No.	Dimension
	Male inserts for male contacts Without contacts (to be ordered separately) CR TT heat-shrinking insulating tube for CY 16 contacts or for conductor with external diameter < 10 mm	CX 01 YM	
	Female inserts for female contacts Without contacts (to be ordered separately) CR TT heat-shrinking insulating tube for CY 16 contacts or for conductor with external diameter < 10 mm	CX 01 YF	

200 A crimp contacts	section (mm ²)		section (AWG)		Male	Female
	16	25	35	50	70	CYMA 16 CYMA 25 CYMA 35 CYMA 50 CYMA 70
					silver	



Wiring information, CY contacts

conductor section (mm ²)	conductor slot ø A (mm)	stripping length (mm)
16	6,1	15
25	7,0	15
35	8,2	15
50	9,8	15
70	11,8	15

Wire diameter: up to 15,7 mm.

It is recommended to use the crimping tools and removal tools homologated by ILME (please see page [F.23](#))

Materials

Insert	polycarbonate (PC)
UL 94 flame rating	V-0
Colour	pebble grey, RAL 7032
Contacts	copper alloy, silver ● plated



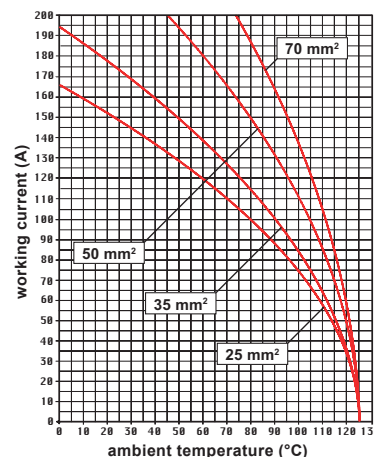
CGT..
PE wire terminal adapter
Page [C.96](#)

Accessories

Pages

MIXO Frames

Metal frames for modular units	C.95
Thermoplastic docking frames	C.98-101



CX 01 Y inserts max. current load derating diagram

Can be used in bulkhead mounting housings or in high construction housings or in high construction hoods.

CX 01 YPE

size **2 modules**
1 PE pole


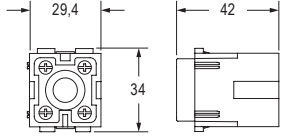

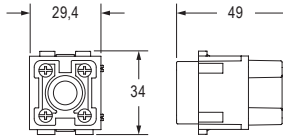

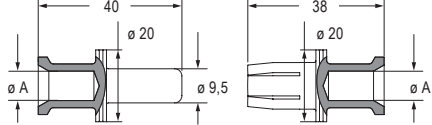

Crimp connection

EN 61984 rating	—
Rated voltage (UL / CSA)	—
Insulation resistance	—
Contact resistance	≤ 0,2 mΩ
Ambient temperature limit	-40 °C ... +125 °C
Mechanical life (cycles)	≥ 500

CE UK EAC



ECBT2.E115072 | ECBT8.E115072
PVVA2.E506437 | PVVA8.E506437

Item	Description	Part No.	Dimension																										
	PE male inserts for male contacts Without contacts (to be ordered separately)	CX 01 YPEM																											
	PE female inserts for female contacts Without contacts (to be ordered separately)	CX 01 YPEF																											
	200 A crimp contacts <table border="1"> <thead> <tr> <th>section (mm²)</th> <th>section (AWG)</th> </tr> </thead> <tbody> <tr> <td>16</td> <td>6</td> </tr> <tr> <td>25</td> <td>4</td> </tr> <tr> <td>35</td> <td>2</td> </tr> <tr> <td>50</td> <td>1</td> </tr> <tr> <td>70</td> <td>2/0</td> </tr> </tbody> </table>	section (mm ²)	section (AWG)	16	6	25	4	35	2	50	1	70	2/0	<table border="1"> <thead> <tr> <th></th> <th>Male</th> <th>Female</th> </tr> </thead> <tbody> <tr> <td rowspan="5" style="writing-mode: vertical-rl; transform: rotate(180deg);">silver</td> <td>CYMA 16</td> <td>CYFA 16</td> </tr> <tr> <td>CYMA 25</td> <td>CYFA 25</td> </tr> <tr> <td>CYMA 35</td> <td>CYFA 35</td> </tr> <tr> <td>CYMA 50</td> <td>CYFA 50</td> </tr> <tr> <td>CYMA 70</td> <td>CYFA 70</td> </tr> </tbody> </table>		Male	Female	silver	CYMA 16	CYFA 16	CYMA 25	CYFA 25	CYMA 35	CYFA 35	CYMA 50	CYFA 50	CYMA 70	CYFA 70	
section (mm ²)	section (AWG)																												
16	6																												
25	4																												
35	2																												
50	1																												
70	2/0																												
	Male	Female																											
silver	CYMA 16	CYFA 16																											
	CYMA 25	CYFA 25																											
	CYMA 35	CYFA 35																											
	CYMA 50	CYFA 50																											
	CYMA 70	CYFA 70																											
Materials Insert: polycarbonate (PC) UL 94 flame rating: V-0 Colour: green, RAL 6011 Contacts: copper alloy, silver ● plated			 <p>CGT.. PE wire terminal adapter Page C.96</p>																										
Wiring information, CY contacts <table border="1"> <thead> <tr> <th>conductor section (mm²)</th> <th>conductor slot ø A (mm)</th> <th>stripping length (mm)</th> </tr> </thead> <tbody> <tr> <td>16</td> <td>6,1</td> <td>15</td> </tr> <tr> <td>25</td> <td>7,0</td> <td>15</td> </tr> <tr> <td>35</td> <td>8,2</td> <td>15</td> </tr> <tr> <td>50</td> <td>9,8</td> <td>15</td> </tr> <tr> <td>70</td> <td>11,8</td> <td>15</td> </tr> </tbody> </table> <p>Wire diameter: up to 15,7 mm. It is recommended to use the crimping tools and removal tools homologated by ILME (please see page F.23)</p>			conductor section (mm ²)	conductor slot ø A (mm)	stripping length (mm)	16	6,1	15	25	7,0	15	35	8,2	15	50	9,8	15	70	11,8	15									
conductor section (mm ²)	conductor slot ø A (mm)	stripping length (mm)																											
16	6,1	15																											
25	7,0	15																											
35	8,2	15																											
50	9,8	15																											
70	11,8	15																											
Accessories <table border="1"> <thead> <tr> <th></th> <th>Pages</th> </tr> </thead> <tbody> <tr> <td>MIXO Frames</td> <td></td> </tr> <tr> <td>Metal frames for modular units</td> <td>C.95</td> </tr> <tr> <td>Thermoplastic docking frames</td> <td>C.98-101</td> </tr> </tbody> </table>				Pages	MIXO Frames		Metal frames for modular units	C.95	Thermoplastic docking frames	C.98-101																			
	Pages																												
MIXO Frames																													
Metal frames for modular units	C.95																												
Thermoplastic docking frames	C.98-101																												

CX 01 YA

200 A 1000 V

size **2 modules**
1 pole

Screw connection

EN 61984 rating	200 A 1000 V 8 kV 3
Rated voltage (UL / CSA)	600 V
Insulation resistance	≥ 10 GΩ
Contact resistance	≤ 3 mΩ
Ambient temperature limit	-40 °C ... +125 °C
Mechanical life (cycles)	≥ 500

(pending: EAC)

(pending: CQC)

ECBT2.E115072 | ECBT8.E115072
(pending: PVVA2.E506437 | PVVA8.E506437)

Item	Description	Part No.	Dimension
	Male inserts with male contact Screw terminal connection - 90° angled	CX 01 YAM	
	Female inserts with female contact Screw terminal connection - 90° angled	CX 01 YAF	



Watch our clip

Materials

Insert	polycarbonate (PC)
UL 94 flame rating	V-0
Colour	pebble grey, RAL 7032
Contacts	built-in, copper alloy, silver ● plated

Wiring information

Wires cross sectional area	10 mm ² - 70 mm ² (AWG 8-2/0)
Terminal screw	M6 TORX® T30
Terminal screw torque	3 Nm max. (26.55 lb.in)

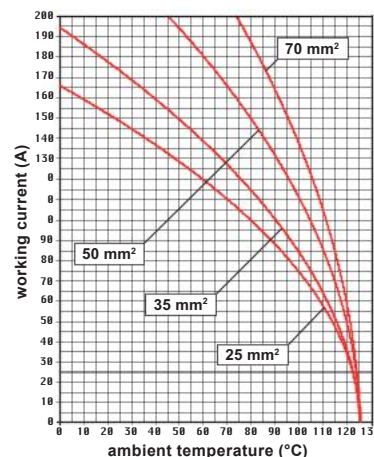
CGT..
PE wire terminal adapter
Page [C.96](#)

Accessories

Pages

MIXO Frames

Metal frames for modular units	C.96
Thermoplastic docking frames	C.98-101



CX 01 YA inserts max. current load derating diagram

Can be used in bulkhead mounting housings only.

CX 01 YPEA

size **2 modules**
1 PE pole


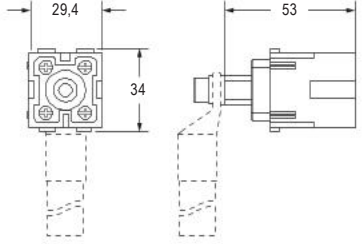

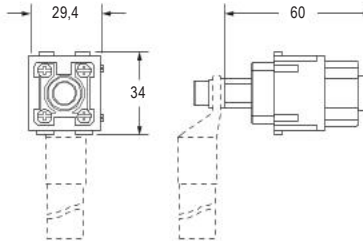
Screw connection

EN 61984 rating	—
Rated voltage (UL / CSA)	—
Insulation resistance	—
Contact resistance	≤ 3 mΩ
Ambient temperature limit	-40 °C ... +125 °C
Mechanical life (cycles)	≥ 500

CE UK (pending: EAC)

DNV (pending: CQC)

ECBT2.E115072 | ECBT8.E115072
CULUS (pending: PVVA2.E506437 | PVVA8.E506437)

Item	Description	Part No.	Dimension
	PE male inserts with male contacts Screw terminal connection - 90° angled	CX 01 YPEAM	
	PE female inserts with female contacts Screw terminal connection - 90° angled	CX 01 YPEAF	

Materials		Wiring information	
Insert	polycarbonate (PC)	Wires cross sectional area	10 mm ² - 70 mm ² (AWG 8-2/0)
UL 94 flame rating	V-0	Terminal screw	M6 TORX® T30
Colour	green, RAL 6011	Terminal screw torque	3 Nm max. (26.55 lb.in)
Contacts	built-in, copper alloy, silver ● plated		



CGT..
PE wire terminal adapter
Page [C.96](#)

Accessories	Pages
MIXO Frames	
Metal frames for modular units	C.96
Thermoplastic docking frames	C.98-101

Can be used in bulkhead mounting housings only.

CX 02 G

100 A 1000 V

size **2 modules**

2 poles

Crimp connection


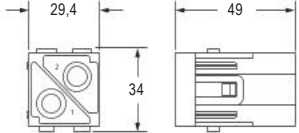

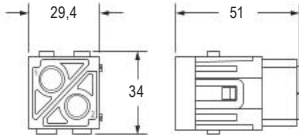
EN 61984 rating	100 A 1000 V 8 kV 3
	100 A 920 / 1600 V 8 kV 2
Rated voltage (UL / CSA)	600 V
Insulation resistance	≥ 10 GΩ
Contact resistance	≤ 0,3 mΩ
Ambient temperature limit	-40 °C ... +125 °C
Mechanical life (cycles)	≥ 500



CE UK (pending: EAC)

SP DNV (pending: CQC)

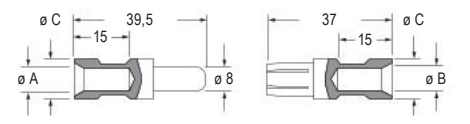
RAI US

ECBT2.E115072 | ECBT8.E115072
PVVA2.E506437 | PVVA8.E506437

Item	Description	Part No.	Dimension
	Male inserts for male contacts Without contacts (to be ordered separately)	CX 02 GM	
	Female inserts for female contacts Without contacts (to be ordered separately)	CX 02 GF	

100 A crimp contacts	Male	Female		
section (mm ²)				
8-10	8-7		CGMA 10	CGFA 10
16	6-5		CGMA 16	CGFA 16
25	4-3		CGMA 25	CGFA 25
35	2		CGMA 35	CGFA 35

Male	Female
CGMA 10	CGFA 10
CGMA 16	CGFA 16
CGMA 25	CGFA 25
CGMA 35	CGFA 35



Wiring information, CG contacts

conductor section (mm ²)	conductor slot ø A (mm)	conductor slot ø B (mm)	conductor slot ø C (mm)	stripping length (mm)
8-10	4,3	4,3	13	15
16	5,5	5,5	13	15
25	7,0	7,0	13	15
35	7,9	8,2	12,5	15

Wire diameter: up to 11,5 mm.

It is recommended to use the crimping tools and removal tools homologated by ILME (please see page [E.23](#))

Materials

Insert	polycarbonate (PC)
UL 94 flame rating	V-0
Colour	pebble grey, RAL 7032
Contacts	copper alloy, silver ● plated



CGT..
PE wire terminal adapter
Page [C.96](#)

How to use the PE adapter (CGT 16):

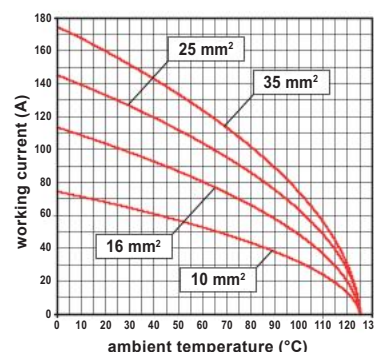
- Strip 15 mm of flexible PE protective cable
- Crimp the cable on the CGT 16 adapter by using the **CPPZ C** pliers with the **CGD 16 C** matrix
- Fix the adapter tip in the larger earth terminal (6 mm²) of frames **CX...TM/TF**

Accessories

Pages

MIXO Frames

Metal frames for modular units	C.98
Thermoplastic docking frames	C.98-101



CX 02 G inserts max. current load derating diagram

On request, version with pole 3/4 numbering, references: **CX 02 GMN** and **CX 02 GFN**

Can be used in bulkhead mounting housings or in high construction housings or in high construction hoods.



CX 01 G

100 A 830 V

size **1 module**


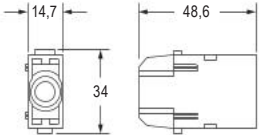

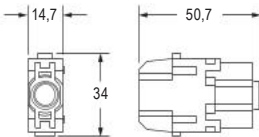
1 pole

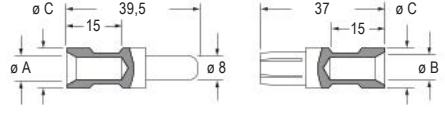








Crimp connection

EN 61984 rating	100 A 830 V 8 kV 3
Rated voltage (UL / CSA)	600 V
Insulation resistance	≥ 10 GΩ
Contact resistance	≤ 0,3 mΩ
Ambient temperature limit	-40 °C ... +125 °C
Mechanical life (cycles)	≥ 500



ECBT2.E115072 | ECBT8.E115072
PVVA2.E506437 | PVVA8.E506437

Item	Description	Part No.	Dimension
	Male inserts for male contacts Without contacts (to be ordered separately)	CX 01 GM	
	Female inserts for female contacts Without contacts (to be ordered separately)	CX 01 GF	

100 A crimp contacts	section (mm ²)		section (AWG)		Male	Female	
	8-10	16	8-7	6-5			
	25	35	4-3	2			
							
							

Wiring information, CG contacts


conductor section (mm ²)	conductor slot ø A (mm)	conductor slot ø B (mm)	conductor slot ø C (mm)	stripping length (mm)
8-10	4,3	4,3	13	15
16	5,5	5,5	13	15
25	7,0	7,0	13	15
35	7,9	8,2	12,5	15

Wire diameter: up to 11,5 mm.

It is recommended to use the crimping tools and removal tools homologated by ILME (please see page [E.23](#))

Materials

Insert	polycarbonate (PC)
UL 94 flame rating	V-0
Colour	pebble grey, RAL 7032
Contacts	copper alloy, silver ● plated



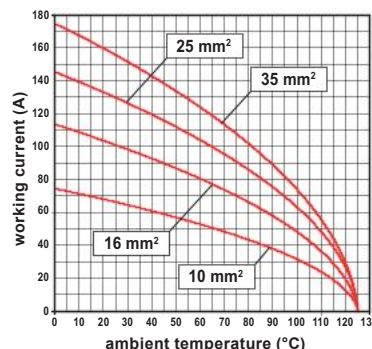
CGT..
PE wire terminal adapter
Page [C.96](#)

How to use the PE adapter (CGT 16):

- Strip 15 mm of flexible PE protective cable
- Crimp the cable on the CGT 16 adapter by using the **CPPZ C** pliers with the **CGD 16 C** matrix
- Fix the adapter tip in the larger earth terminal (6 mm²) of frames **CX...TM/TF**

Accessories	Pages
MIXO Frames	
Metal frames for modular units	C.94-96
Thermoplastic docking frames	C.98-101
Enclosures	
Insulating MIXO holder	C.103
MIXO ONE	C.106-107
MIXO TWO	C.110-111

Can be used in bulkhead mounting housings or in high construction housings or in high construction hoods.



CX 01 G inserts max. current load derating diagram)



Tutorial

CX 02 7


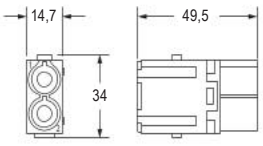

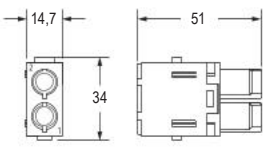
70 A 1000 V

 size **1 module**
2 poles

Crimp connection

EN 61984 rating	70 A 1000 V 8 kV 3
	70 A 1600 V 12 kV 2
Rated voltage (UL / CSA)	600 V
Insulation resistance	≥ 10 GΩ
Contact resistance	≤ 0,5 mΩ
Ambient temperature limit	-40 °C ... +125 °C
Mechanical life (cycles)	≥ 500

 ECBT2.E115072 | ECBT8.E115072
 PVVA2.E506437 | PVVA8.E506437

Item	Description	Part No.	Dimension
	Male inserts for male contacts Without contacts (to be ordered separately)	CX 02 7M	
	Female inserts for female contacts Without contacts (to be ordered separately)	CX 02 7F	

70 A crimp contacts

section (mm ²)	section (AWG)
6	10
10	8-7
16	6-5
16 (XF)*	6-5
25	4-3

Male

silver	CX7MA 6.0
	CX7MA 10
	CX7MA 16
	CX7MA 16 XF
	CX7MA 25

Female

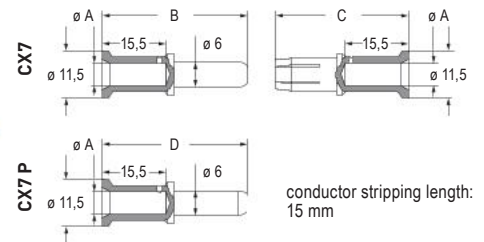
silver	CX7FA 6.0
	CX7FA 10
	CX7FA 16
	CX7FA 16 XF
	CX7FA 25

70 A finger-proof crimp contacts

section (mm ²)	section (AWG)
6	10
10	8-7
16	6-5
16 (XF)*	6-5
25	4-3

silver	CX7MA 6.0 P
	CX7MA 10 P
	CX7MA 16 P
	CX7MA 16 XFP
	CX7MA 25 P

* for extra-flexible Class 6 conductors



Wiring information, CX7 and CX7 P contacts

conductor section (mm ²)	conductor slot ø A (mm)	length B (mm)	length C (mm)	length D (mm)
6	3,5	36,0	33,0	36,6
10	4,3	35,2	32,2	35,8
16	5,5	35,2	32,2	35,8
16 (XF)	6,1	35,2	32,2	35,8
25	7,0	35,2	32,2	35,8

Wire diameter: up to 10 mm.

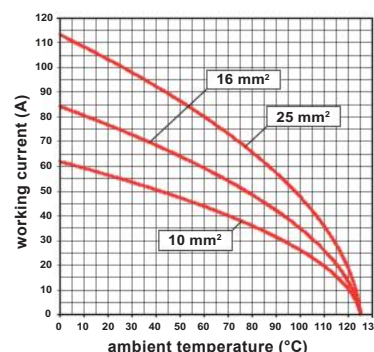
 It is recommended to use the crimping tools and removal tools homologated by ILME (please see page [E.23](#))

Materials

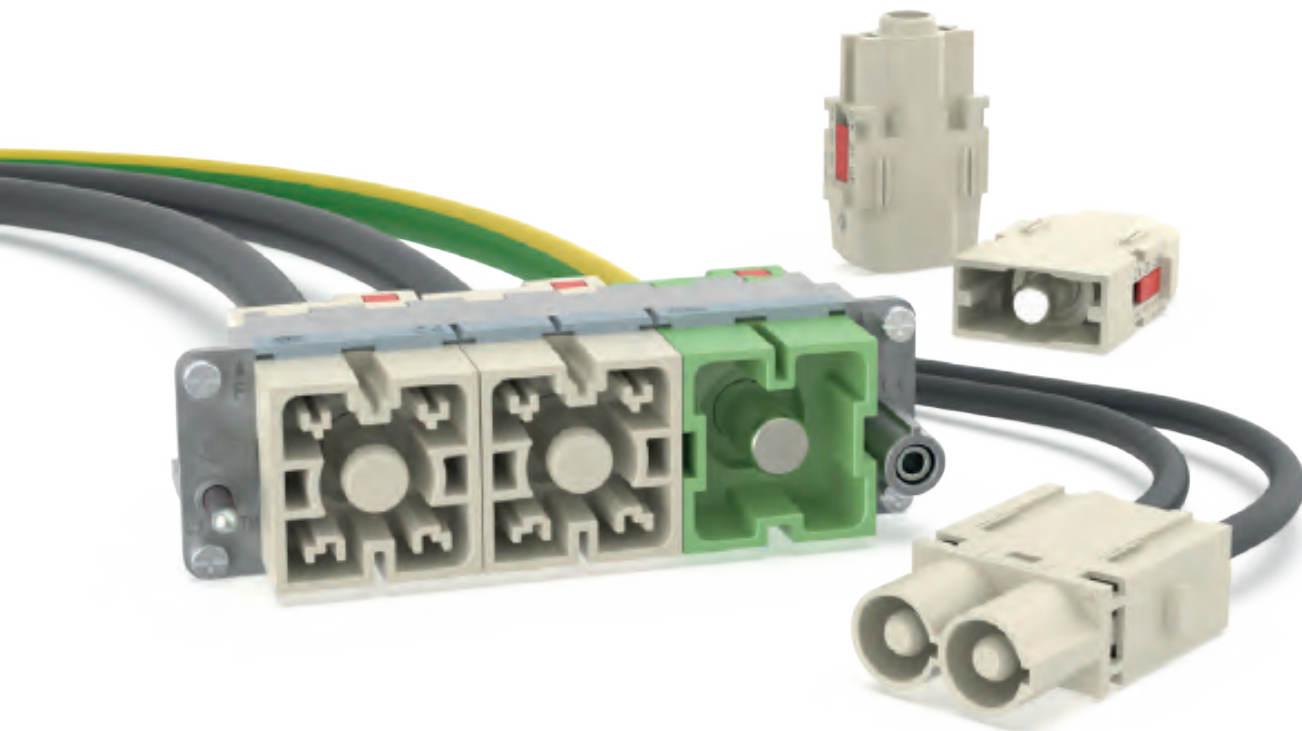
Insert	polycarbonate (PC)
UL 94 flame rating	V-0
Colour	pebble grey, RAL 7032
Contacts	copper alloy, silver ● plated

Accessories

	Pages
MIXO Frames	
Metal frames for modular units	C.94-95
Thermoplastic docking frames	C.98-101
Enclosures	
Insulating MIXO holder	C.103
MIXO ONE	C.106-107
MIXO TWO	C.110-111


CX 02 7 inserts max. current load derating diagram

Can be used in bulkhead mounting housings or in high construction housings or in high construction hoods.



PE modules for MIXO frames



MIXO CX 01 PE

These single-sized modular inserts (male and female) can be combined with all modules requiring the transfer of the PE line in mating connector parts only when mounted in the CX 02 /03 /04 /06 PDF /PDM plastic docking frame corresponding part.

The module has a fool-proof keying in order not to allow its installation and use in a metallic frame of MIXO series. In fact, this PE module is not deemed to provide equipotential bonding between the power PE contact and the metallic frame. Not compatible with CX 01 GPE.

- > “First-make, last-break” function versus any line contact in nearby.

The screw-type terminal can accept PE lines:

- > unprepared flexible (class 5) or rigid (class 1) copper conductors: from 2,5 mm² / AWG 14 to 16 mm² / AWG 6;
- > prepared (ferruled) flexible (class 5) copper conductors: from 1,5 mm² / AWG 16 to 16 mm² / AWG 6.

MIXO CX 01 GPE

The MIXO modular connector series can employ the 1-slot-sized PE module for series CG (100 A) crimp contacts, connecting protective earth lines with large conductor cross sectional areas ranging from 10 mm² / AWG 8 to 35 mm² / AWG 2.

This PE module is particularly suitable in combination with CX 01 GF /M (1-pole, 1-slot sized) and CX 02 GF /GM (2-pole, 2-slot sized) 100 A modules once keeping the same size for the PE wire and the power (phase/neutral) wires so that special multi-core cables with reduced PE size are no longer required.

- > “First-make, last-break” function versus any line contact in nearby;
- > integrated PE springs for bonding to MIXO frames (both sides).

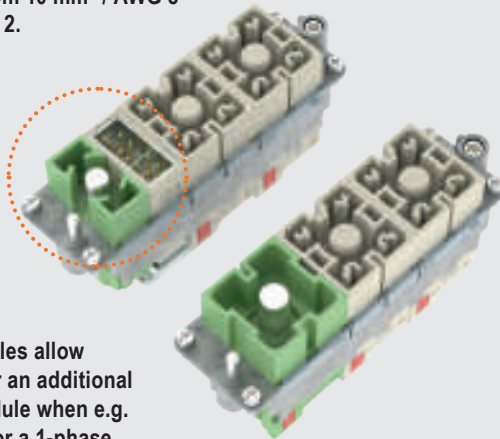


Watch our clip

FOCUS

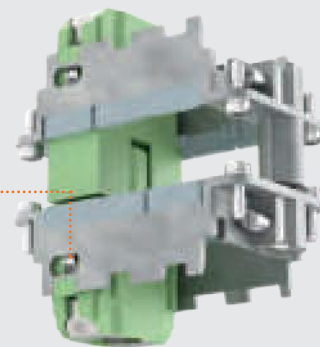
CX 01 GPE insert's features

- ▶ The **1-slot sized PE module** allows the connection of PE lines with large conductor cross sectional areas ranging from 10 mm² / AWG 8 to 35 mm² / AWG 2.

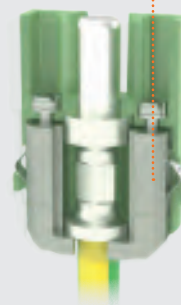


- ▶ CX 01 GPE modules allow **leaving space** for an additional single-sized module when e.g. 2× CX 01 YF /M for a 1-phase circuit are required in a 6-slots MIXO frame.

- ▶ **Integrated PE springs** for bonding to MIXO frames (both sides).



- ▶ **Metallic contact holders** to retain the PE crimped contact and ground to the MIXO frame.

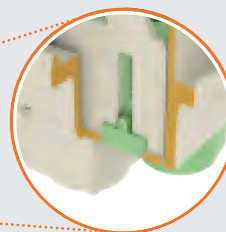
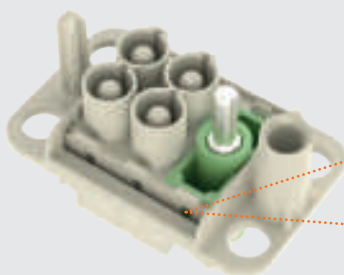


PE modules for MIXO frames

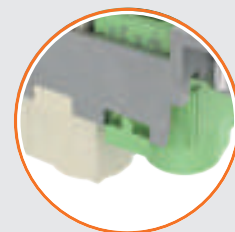
C

FOCUS

CX 01 PE fool-proof keying



▶ ALLOWED



▶ NOT ALLOWED!

- ▶ The CX 01 PE module has a fool-proof keying in order not to allow its installation and use in a metallic frame of MIXO series.

CX 01 GPE

size **1 module**
1 PE pole


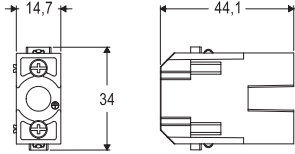

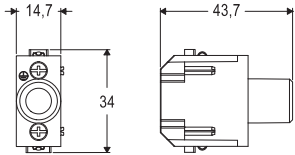
Crimp connection

EN 61984 rating	—
Rated voltage (UL / CSA)	—
Insulation resistance	—
Contact resistance	≤ 0,3 mΩ
Ambient temperature limit	-40 °C ... +125 °C
Mechanical life (cycles)	≥ 500

CE UK (pending: EAC)

(pending: CQC, DNV and BV)

(pending: cURus)

Item	Description	Part No.	Dimension
	PE male insert for male contact Without contact (to be ordered separately)	CX 01 GPEM	
	PE female insert for female contact Without contact (to be ordered separately)	CX 01 GPEF	

100 A crimp contacts

section (mm ²)	section (AWG)
8-10	8-7
16	6-5
25	4-3
35	2

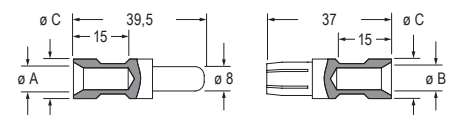
Male

silver

[CGMA 10](#)
[CGMA 16](#)
[CGMA 25](#)
[CGMA 35](#)

Female

[CGFA 10](#)
[CGFA 16](#)
[CGFA 25](#)
[CGFA 35](#)



Wiring information, CG contacts

conductor section (mm ²)	conductor slot ø A (mm)	conductor slot ø B (mm)	conductor slot ø C (mm)	stripping length (mm)
8-10	4,3	4,3	13	15
16	5,5	5,5	13	15
25	7,0	7,0	13	15
35	7,9	8,2	12,5	15

Wire diameter: up to 11,5 mm.

It is recommended to use the crimping tools and removal tools homologated by ILME (please see page F.23)



Watch our clip

Materials

Insert	polycarbonate (PC)
UL 94 flame rating	V-0
Colour	green, RAL 6011
Contacts	copper alloy, silver ● plated

Accessories	Pages
MIXO Frames	
Metal frames for modular units	C.94-95
Thermoplastic docking frames	C.98-101
Enclosures	
Insulating MIXO holder	C.103
MIXO ONE	C.106-107
MIXO TWO	C.110-111

Can be used in bulkhead mounting housings or in high construction housings or in high construction hoods.

CX 01 PE

size **1 module**
1 PE pole


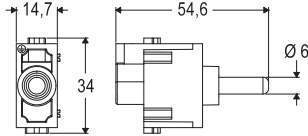

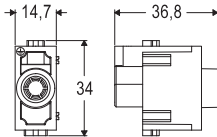
Screw connection

EN 61984 rating	—
Rated voltage (UL / CSA)	—
Insulation resistance	—
Contact resistance	≤ 0,3 mΩ
Ambient temperature limit	-40 °C ... +125 °C
Mechanical life (cycles)	≥ 500

CE UK (pending: EAC)

(pending: CQC, DNV and BV)

(pending: cURus)

Item	Description	Part No.	Dimension
	PE male inserts with male contacts Screw terminal connection	CX 01 PEM	
	PE female inserts with female contacts Screw terminal connection	CX 01 PEF	

Materials	
Insert	polycarbonate (PC)
UL 94 flame rating	V-0
Colour	green, RAL 6011
Contacts	built-in, copper alloy, silver ● plated

Wiring information	
Wire cross sectional area	
- unprepared	2,5 mm ² - 16 mm ² (AWG 14-6)
- prepared	1,5 mm ² - 16 mm ² (AWG 16-6)
Stripping length	14 mm
Terminal screw torque	2,5 Nm (22.2 lb.in)

Accessories	Pages
MIXO Frames	
Thermoplastic docking frames	C.98-101

MIXO Power & Signal modules



AXYR®

High-density, fast & tool-less connection

Product range for 40 A, 16 A and 10 A

The research of new termination technologies aims to develop a reliable and qualitatively stable connection between conductor and contact, meeting any possible application requirement in terms of current carrying-capacity and available number of poles, as much as possible independently from the skill of the operator.

Crimped connection, with its typical irreversible process, achieves the best performance and the highest possible connection density, but requires specific wiring procedures and special tools, while being also non-rewireable.



Watch our clip

ILME **AXYR**® technology offers an extremely compact spring push-in termination, which equals the crimp connectors in high density, but requires no special crimping tool, yet granting an optimal electrical performance.

An easy, **tool-less** and **operator skill independent** connection, resistant to mechanical stress and vibrations, suitable for any installation requirement.

- > **AXYR**® features a harmonic steel spring and a tiny, yet stiff, properly designed actuator button working together to allow a simple push-in action guaranteeing a safe wiring.
- > Thanks to a boxed terminal, the wire contact pressure does not rely upon surrounding insulating parts, likely to possibly relax under heating when the connector is under current load.
- > Solid and prepared flexible wires, when sufficiently stiff, can be directly inserted into the connection terminal; unprepared stranded wires require instead the initial opening of the spring by means of a simple flat-blade screwdriver, thanks to the actuator button.
- > **AXYR**® technology makes the user free to choose the connector that best suits his needs, naturally reusable and independent of the required wire cross-section, compatible with the crimp connectors of the ILME product portfolio: one size fits the whole range of cross-sectional areas (compared to competing solution with radial spring that require two sizes).

FOCUS

AXYR® tool-less connection

> Simple push-in action

Solid or Prepared wires:
cross-sectional area $\geq 0,75 \text{ mm}^2$ / 18 AWG



- ▶ Deeply insert the solid or prepared wire into the contact hole.






- ▶ The wire is safely secured by the spring clamp.

> With flat-blade screwdriver

Stranded wires: all cross-sectional areas
Solid or Prepared wires: cross-sectional area $< 0,75 \text{ mm}^2$ / 18 AWG



- ▶ Push down the actuator button by a flat-blade screwdriver
-  0,5 × 3 mm max. for 10 A
-  0,5 × 3,5 mm max. for 16 A
-  0,8 × 4,5 mm max. for 40 A

insert the stranded wire, previously stripped and twisted, into the contact hole, or the solid or prepared wire of small size.



- ▶ The wire is safely secured by the spring clamp.

CX 02 4A/CX 02 4B

40 A 1000 V


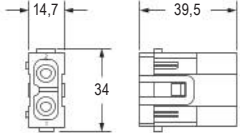

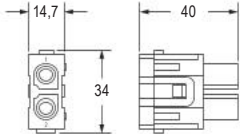

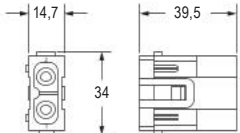

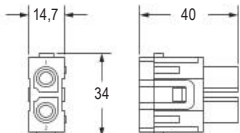
 size **1 module**
2 poles

Axial screw connection

EN 61984 rating	40 A 1000 V 8 kV 3
	40 A 1600 V 12 kV 2
Rated voltage (UL / CSA)	600 V
Insulation resistance	≥ 10 GΩ
Contact resistance	≤ 0,5 mΩ
Ambient temperature limit	-40 °C ... +125 °C
Mechanical life (cycles)	≥ 500



ECBT2.E115072 | ECBT8.E115072

Item	Description	Part No.	Dimension
	Male inserts with male contacts Screw terminal connection Wire diameter: up to 4 mm	CX 02 4AM	
	Female inserts with female contacts Screw terminal connection Wire diameter: up to 4 mm	CX 02 4AF	
	Male inserts with male contacts Screw terminal connection Wire diameter: up to 4,8 mm	CX 02 4BM	
	Female inserts with female contacts Screw terminal connection Wire diameter: up to 4,8 mm	CX 02 4BF	

Materials

Insert	polycarbonate (PC)
UL 94 flame rating	V-0
Colour	pebble grey, RAL 7032
Contacts	built-in, copper alloy, silver ● plated

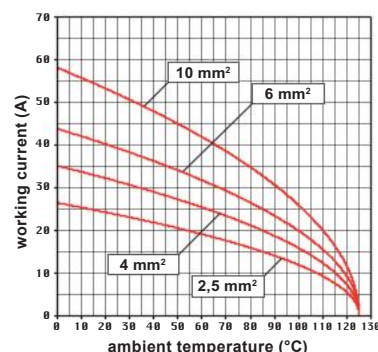
- Use flexible cables with section from 2,5 mm² to 10 mm² or extra flexible cables with sections from 2,5 mm² to 6 mm²;
- do not twist the cables;
- fully insert the braids in the rear section of the contact;
- insert a 2 mm hexagonal key in the front section of the contact and tighten by keeping the cable held down in position;
- a 2 mm hexagonal key can be supplied on request, reference **CX AS**.

Wiring information

Wires cross sectional area	
- inserts for ø 4 mm cables (CX..4A)	2,5 mm ² - 8 mm ² (AWG 14-8)
- inserts for ø 4,8 mm cables (CX..4B)	6 mm ² - 10 mm ² (AWG 10-8)
Stripping length	
- 2,5 mm ² - 4 mm ² (AWG 14-12)	5+1
- 6 mm ² - 10 mm ² (AWG 10-8)	8+1
Terminal screw torque	
- 2,5 mm ² - 4 mm ² (AWG 14-12)	1,5 Nm (13.3 lb.in)
- 6 mm ² - 10 mm ² (AWG 10-8)	2 Nm (17.7 lb.in)

Accessories

Accessories	Pages
MIXO Frames	
Metal frames for modular units	C.94-95
Thermoplastic docking frames	C.98-101
Enclosures	
Insulating MIXO holder	C.103
MIXO ONE	C.106-107
MIXO TWO	C.110-111


CX 02 4A/4B inserts max. current load derating diagram

CX 02 4

40 A 1000 V



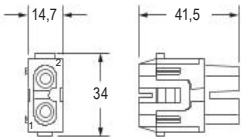
size **1 module**
2 poles

Crimp connection

EN 61984 rating	40 A 1000 V 8 kV 3
Rated voltage (UL / CSA)	600 V
Insulation resistance	≥ 10 GΩ
Contact resistance	≤ 0,3 mΩ
Ambient temperature limit	-40 °C ... +125 °C
Mechanical life (cycles)	≥ 500


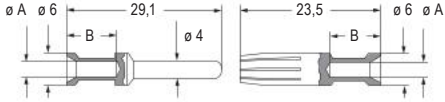


ALUS ECBT2.E115072 | ECBT8.E115072

Item	Description	Part No.	Dimension
	Male inserts for male contacts Without contacts (to be ordered separately)	CX 02 4M	
	Female inserts for female contacts Without contacts (to be ordered separately)	CX 02 4F	

40 A crimp contacts	section (mm ²)		section (AWG)		Male	Female
		1,5	2,5	16	14	CXMA 1.5
	4	6	12	10	CXMA 4.0	CXFA 4.0
	10		8		CXMA 10	CXFA 10

silver

Wiring information, CX contacts

conductor section (mm ²)	conductor slot ø A (mm)	stripping length B (mm)
1,5	1,8	9
2,5	2,2	9
4	2,85	9,6
6	3,5	9,6
10	4,3	15

Wire diameter: up to 7 mm.

It is recommended to use the crimping tools and removal tools homologated by ILME (please see page [E.23](#))

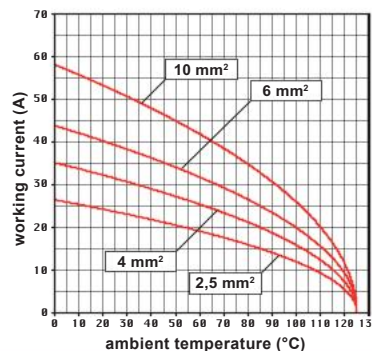
Materials

Insert	polycarbonate (PC)
UL 94 flame rating	V-0
Colour	pebble grey, RAL 7032
Contacts	copper alloy, silver ● plated

Accessories

	Pages
MIXO Frames	
Metal frames for modular units	C.94-98
Thermoplastic docking frames	C.98-101
Enclosures	
Insulating MIXO holder	C.103
MIXO ONE	C.106-107
MIXO TWO	C.110-111

Can be used in bulkhead mounting housings or in high construction housings or in high construction hoods.



CX 02 4 inserts max. current load derating diagram


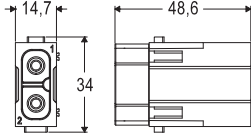

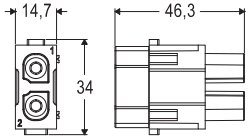
CX 02 4Y**40 A 1000 V**size **1 module****2 poles****Tool-less connection – AXYR®**

EN 61984 rating	40 A 1000 V 8 kV 3
Rated voltage (UL / CSA) (pending)	600 V
Insulation resistance	≥ 10 GΩ
Contact resistance	≤ 0,5 mΩ
Ambient temperature limit	-40 °C ... +125 °C
Mechanical life (cycles)	≥ 500

CE UK (pending: EAC)

(pending: CQC, DNV and BV)

(pending: cURus)

Item	Description	Part No.	Dimension
	Male inserts with male contacts Spring/AXYR® push-in connection	CX 02 4YM	
	Female inserts with female contacts Spring/AXYR® push-in connection	CX 02 4YF	

Materials

Insert	polycarbonate (PC)
UL 94 flame rating	V-0
Colour	pebble grey, RAL 7032
Contacts	built-in, copper alloy, silver ● plated

Wiring information

Wire cross sectional area	
- unprepared	1,5 mm ² - 6 mm ² (AWG 16-10)
- prepared	1,5 mm ² - 6 mm ² (AWG 16-10)
Stripping length	9...11 mm

Wire diameter: up to 7 mm.

Accessories**MIXO Frames**

	Pages
Metal frames for modular units	C.94-95
Thermoplastic docking frames	C.98-101

Enclosures

Insulating MIXO holder	C.103
MIXO ONE	C.106-107
MIXO TWO	C.110-111

Can be used in bulkhead mounting housings or in high construction housings or in high construction hoods.

CX 04 X

40 A 830 V

size **1 module**

4 poles

Crimp connection

EN 61984 rating	40 A 830 V 8 kV 3
	40 A 1000 V 8 kV 2
Rated voltage (UL / CSA)	600 V
Insulation resistance	≥ 10 GΩ
Contact resistance	≤ 0,3 mΩ
Ambient temperature limit	-40 °C ... +125 °C
Mechanical life (cycles)	≥ 500

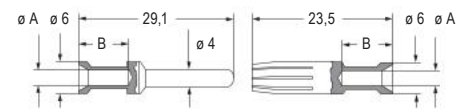


ECBT2.E115072 | ECBT8.E115072
PVVA2.E506437 | PVVA8.E506437

Item	Description	Part No.	Dimension
	Male inserts for male contacts Without contacts (to be ordered separately) Male insert is protected from access with the back of the hand (IP1X or IPXXA)	CX 04 XM	
	Female inserts for female contacts Without contacts (to be ordered separately) Female insert is finger proof (IP2X or IPXXB) even if not coupled Female inserts are supplied with × 2 red lock-in tab that must be used instead of those supplied with the frames (code CX CFMX)	CX 04 XF	

40 A crimp contacts	section (mm ²)		section (AWG)		Male	Female
		1,5	16	2,5	14	CXMA 1.5
	2,5	14	4	12	CXMA 2.5	CXFA 2.5
	4	12	6	10	CXMA 4.0	CXFA 4.0
	6	10			CXMA 6.0	CXFA 6.0

silver



Wiring information, CX contacts

conductor section (mm ²)	conductor slot ø A (mm)	stripping length B (mm)
1,5	1,8	9
2,5	2,2	9
4	2,85	9,6
6	3,5	9,6

Wire diameter: up to 5,3 mm.

It is recommended to use the crimping tools and removal tools homologated by ILME (please see page [E.23](#))

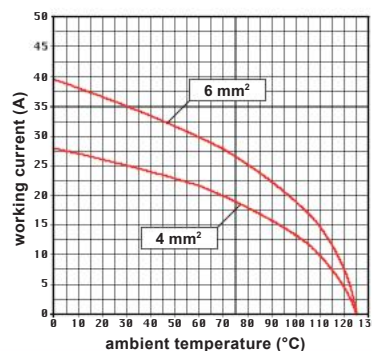
Materials

Insert	polycarbonate (PC)
UL 94 flame rating	V-0
Colour	pebble grey, RAL 7032
Contacts	copper alloy, silver ● plated

Accessories

	Pages
MIXO Frames	
Metal frames for modular units	C.94-96
Thermoplastic docking frames	C.98-101
Enclosures	
Insulating MIXO holder	C.103
MIXO ONE	C.106-107
MIXO TWO	C.110-111

Can be used in bulkhead mounting housings or in high construction housings or in high construction hoods.



CX 04 X inserts max. current load derating diagram

CX 04 XY

40 A 830 V

size **1 module**

4 poles


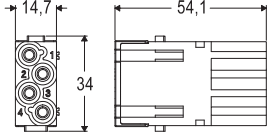

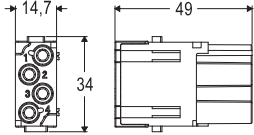
Tool-less connection – AXYR®

EN 61984 rating	40 A 830 V 8 kV 3
Rated voltage (UL / CSA) (pending)	600 V
Insulation resistance	≥ 10 GΩ
Contact resistance	≤ 0,5 mΩ
Ambient temperature limit	-40 °C ... +125 °C
Mechanical life (cycles)	≥ 500

CE UK (pending: EAC)

(pending: CQC, DNV and BV)

(pending: cURus)

Item	Description	Part No.	Dimension
	Male inserts with male contacts Spring/ AXYR ® push-in connection Male insert is protected from access with the back of the hand (IP1X or IPXXA)	CX 04 XYM	
	Female inserts with female contacts Spring/ AXYR ® push-in connection Female insert is finger proof (IP2X or IPXXB) even if not coupled Female inserts are supplied with × 2 red lock-in tab that must be used instead of those supplied with the frames (code CX CFMX)	CX 04 XYF	

Materials

Insert	polycarbonate (PC)
UL 94 flame rating	V-0
Colour	pebble grey, RAL 7032
Contacts	built-in, copper alloy, silver ● plated

Wiring information

Wire cross sectional area	
- unprepared	1,5 mm ² - 6 mm ² (AWG 16-10)
- prepared	1,5 mm ² - 4 mm ² (AWG 16-12)
Stripping length	9...11 mm

Wire diameter: up to 6 mm.

Accessories

Accessories	Pages
MIXO Frames	
Metal frames for modular units	C.94-95
Thermoplastic docking frames	C.98-101
Enclosures	
Insulating MIXO holder	C.103
MIXO ONE	C.106-107
MIXO TWO	C.110-111

Can be used in bulkhead mounting housings or in high construction housings or in high construction hoods.

CX 3/4 XD

40 A 830 V / 10 A 830 V

size **1 module**

3 / 4 poles

Crimp connection

EN 61984 rating	40 A 830 V 8 kV 3
	10 A 830 V 8 kV 3
Rated voltage (UL / CSA)	600 V
Insulation resistance	≥ 10 GΩ
Contact resistance	40 A (3 poles) ≤ 0,3 mΩ
	10 A (4 poles) ≤ 3 mΩ
Ambient temperature limit	-40 °C ... +125 °C
Mechanical life (cycles)	≥ 500



ECBT2.E115072 | ECBT8.E115072
PVVA2.E506437 | PVVA8.E506437

Item	Description	Part No.	Dimension
	Male inserts for male contacts Without contacts (to be ordered separately) Male insert is protected from access with the back of the hand (IP1X or IPXXA)	CX 3/4 XDM	

	Female inserts for female contacts Without contacts (to be ordered separately) Female insert is finger proof (IP2X or IPXXB) even if not coupled	CX 3/4 XDF	
--	--	----------------------------	--

	40 A crimp contacts	10 A crimp contacts	Male	Female	
	section (mm ²) section (AWG) 1,5 16 2,5 14 4 12 6 10	section (mm ²) section (AWG) 0,14-0,37 26-22 0,5 20 0,75 18 1 18 1,5 16 2,5 14	silver	CXMA 1.5 CXFA 1.5 CXMA 2.5 CXFA 2.5 CXMA 4.0 CXFA 4.0 CXMA 6.0 CXFA 6.0	
	section (mm ²) section (AWG) 0,14-0,37 26-22 0,5 20 0,75 18 1 18 1,5 16 2,5 14	section (mm ²) section (AWG) 0,14-0,37 26-22 0,5 20 0,75 18 1 18 1,5 16 2,5 14	silver	CDMA 0.3 CDFA 0.3 CDMA 0.5 CDFA 0.5 CDMA 0.7 CDFA 0.7 CDMA 1.0 CDFA 1.0 CDMA 1.5 CDFA 1.5 CDMA 2.5 CDFA 2.5	
	section (mm ²) section (AWG) 0,14-0,37 26-22 0,5 20 0,75 18 1 18 1,5 16 2,5 14	section (mm ²) section (AWG) 0,14-0,37 26-22 0,5 20 0,75 18 1 18 1,5 16 2,5 14	gold	CDMD 0.3 CDFD 0.3 CDMD 0.5 CDFD 0.5 CDMD 0.7 CDFD 0.7 CDMD 1.0 CDFD 1.0 CDMD 1.5 CDFD 1.5 CDMD 2.5 CDFD 2.5	

Wiring information, CX and CD contacts

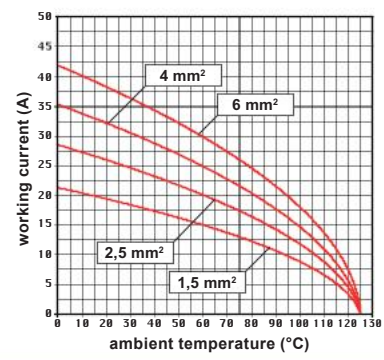
conductor section (mm ²)	conductor slot ø A (mm)	stripping length B (mm)	conductor section (mm ²)	conductor slot ø C (mm)	stripping length D (mm)
1,5	1,8	9	0,14-0,37	0,9	8
2,5	2,2	9	0,5	1,1	8
4	2,85	9,6	0,75	1,3	8
6	3,5	9,6	1,0	1,45	8
-	-	-	1,5	1,8	8
-	-	-	2,5	2,2	6

Wire diameter: up to 5,3 mm (CX series); up to 3,8 mm (CD series).
For basic or high thickness gold plating, please refer to page [E.14](#).

It is recommended to use the crimping tools and removal tools homologated by ILME (please see page [E.23](#))

Materials	
Insert	polycarbonate (PC)
UL 94 flame rating	V-0
Colour	pebble grey, RAL 7032
Contacts	copper alloy, silver ● and gold ● plated

Accessories	Pages
MIXO Frames	
Metal frames for modular units	C.94-96
Thermoplastic docking frames	C.98-101
Enclosures	
Insulating MIXO holder	C.103
MIXO ONE	C.106-107
MIXO TWO	C.110-111



CX 3/4 XD inserts max. current load derating diagram

CX 03 4B

40 A 500 V


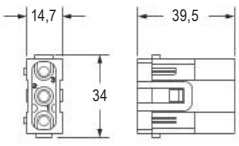

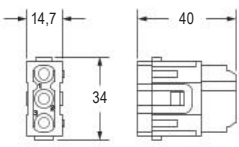
size **1 module**


3 poles

Crimp connection

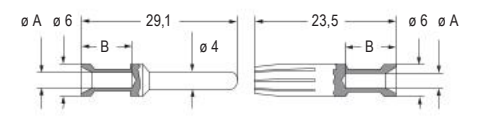
EN 61984 rating	40 A 500 V 6 kV 3
Rated voltage (UL / CSA)	600 V
Insulation resistance	≥ 10 GΩ
Contact resistance	≤ 0,3 mΩ
Ambient temperature limit	-40 °C ... +125 °C
Mechanical life (cycles)	≥ 500



Item	Description	Part No.	Dimension
	Male inserts for male contacts Without contacts (to be ordered separately)	CX 03 4BM	
	Female inserts for female contacts Without contacts (to be ordered separately)	CX 03 4BF	

40 A crimp contacts	section (mm ²)		section (AWG)		Male	Female
		1,5	16	2,5	14	CXMA 1.5
	2,5	14	4	12	CXMA 2.5	CXFA 2.5
	4	12	6	10	CXMA 4.0	CXFA 4.0
	6	10	10	8	CXMA 6.0	CXFA 6.0
	10	8			CXMA 10	CXFA 10

silver



Wiring information, CX contacts

conductor section (mm ²)	conductor slot ø A (mm)	stripping length B (mm)
1,5	1,8	9
2,5	2,2	9
4	2,85	9,6
6	3,5	9,6
10	4,3	15

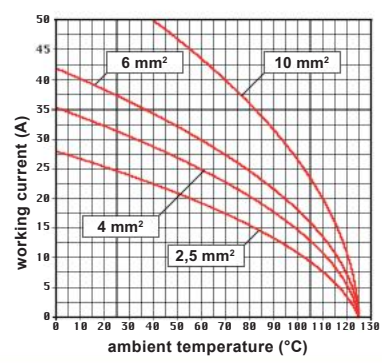
Wire diameter: up to 7 mm

It is recommended to use the crimping tools and removal tools homologated by ILME (please see page [E.23](#))

Materials

Insert	polycarbonate (PC)
UL 94 flame rating	V-0
Colour	pebble grey, RAL 7032
Contacts	copper alloy, silver ● plated

Accessories	Pages
MIXO Frames	
Metal frames for modular units	C.94-95
Thermoplastic docking frames	C.98-101
Enclosures	
Insulating MIXO holder	C.103
MIXO ONE	C.106-107
MIXO TWO	C.110-111



CX 03 4B inserts max. current load derating diagram

Can be used in bulkhead mounting housings or in high construction housings or in high construction hoods.

CX 03 4

40 A 400/690 V

size **1 module**

3 poles

Crimp connection


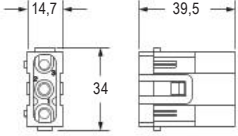

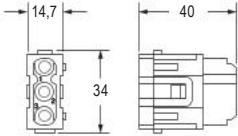

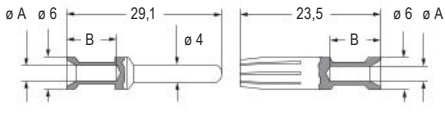
EN 61984 rating	40 A 400 / 690 V 6 kV 3
Rated voltage (UL / CSA)	600 V
Insulation resistance	≥ 10 GΩ
Contact resistance	≤ 0,3 mΩ
Ambient temperature limit	-40 °C ... +125 °C
Mechanical life (cycles)	≥ 500

CE UK EAC



ILME

ECBT2.E115072 | ECBT8.E115072
PVVA2.E506437 | PVVA8.E506437

Item	Description	Part No.	Dimension															
	Male inserts for male contacts Without contacts (to be ordered separately)	CX 03 4M																
	Female inserts for female contacts Without contacts (to be ordered separately)	CX 03 4F																
	40 A crimp contacts section (mm ²) section (AWG)	<table border="1"> <thead> <tr> <th></th> <th>Male</th> <th>Female</th> </tr> </thead> <tbody> <tr> <td>1,5</td> <td>CXMA 1.5</td> <td>CXFA 1.5</td> </tr> <tr> <td>2,5</td> <td>CXMA 2.5</td> <td>CXFA 2.5</td> </tr> <tr> <td>4</td> <td>CXMA 4.0</td> <td>CXFA 4.0</td> </tr> <tr> <td>6</td> <td>CXMA 6.0</td> <td>CXFA 6.0</td> </tr> </tbody> </table>		Male	Female	1,5	CXMA 1.5	CXFA 1.5	2,5	CXMA 2.5	CXFA 2.5	4	CXMA 4.0	CXFA 4.0	6	CXMA 6.0	CXFA 6.0	
	Male	Female																
1,5	CXMA 1.5	CXFA 1.5																
2,5	CXMA 2.5	CXFA 2.5																
4	CXMA 4.0	CXFA 4.0																
6	CXMA 6.0	CXFA 6.0																

Wiring information, CX contacts

conductor section (mm ²)	conductor slot ø A (mm)	stripping length B (mm)
1,5	1,8	9
2,5	2,2	9
4	2,85	9,6
6	3,5	9,6

Wire diameter: up to 5,3 mm

It is recommended to use the crimping tools and removal tools homologated by ILME (please see page [E.23](#))

Materials

Insert	polycarbonate (PC)
UL 94 flame rating	V-0
Colour	pebble grey, RAL 7032
Contacts	copper alloy, silver ● plated

Accessories

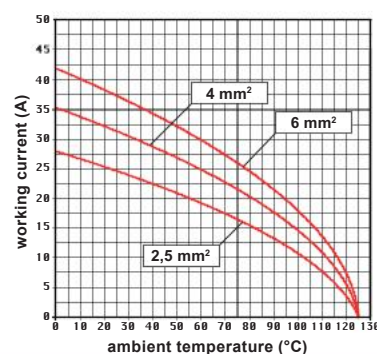
Pages

MIXO Frames

Metal frames for modular units	C.94-98
Thermoplastic docking frames	C.98-101

Enclosures

Insulating MIXO holder	C.103
MIXO ONE	C.106-107
MIXO TWO	C.110-111



CX 03 4 inserts max. current load derating diagram


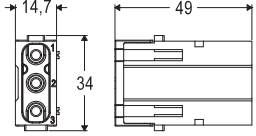

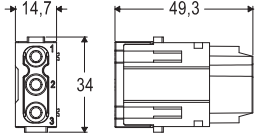
CX 03 4Y**40 A 690 V**size **1 module****3 poles****Tool-less connection – AXYR®**

EN 61984 rating	40 A 690 V 8 kV 3
Rated voltage (UL / CSA) (pending)	600 V
Insulation resistance	≥ 10 GΩ
Contact resistance	≤ 0,5 mΩ
Ambient temperature limit	-40 °C ... +125 °C
Mechanical life (cycles)	≥ 500

CE UK (pending: EAC)

(pending: CQC, DNV and BV)

(pending: cURus)

Item	Description	Part No.	Dimension
	Male inserts with male contacts Spring/AXYR® push-in connection	CX 03 4YM	
	Female inserts with female contacts Spring/AXYR® push-in connection	CX 03 4YF	

Materials

Insert	polycarbonate (PC)
UL 94 flame rating	V-0
Colour	pebble grey, RAL 7032
Contacts	built-in, copper alloy, silver ● plated

Wiring information

Wire cross sectional area	
- unprepared	1,5 mm ² - 6 mm ² (AWG 16-10)
- prepared	1,5 mm ² - 6 mm ² (AWG 16-10)
Stripping length	9...11 mm

Wire diameter: up to 7 mm.

Accessories

	Pages
MIXO Frames	
Metal frames for modular units	C.94-95
Thermoplastic docking frames	C.98-101
Enclosures	
Insulating MIXO holder	C.103
MIXO ONE	C.106-107
MIXO TWO	C.110-111

Can be used in bulkhead mounting housings or in high construction housings or in high construction hoods.

CX 06P C

16 A 830 V

size **1 module**

6 poles

Crimp connection

EN 61984 rating	16 A 830 V 8 kV 3
Rated voltage (UL / CSA)	600 V
Insulation resistance	≥ 10 GΩ
Contact resistance	≤ 1 mΩ
Ambient temperature limit	-40 °C ... +125 °C
Mechanical life (cycles)	≥ 500



ECBT2.E115072 | ECBT8.E115072
PVVA2.E506437 | PVVA8.E506437

Item	Description	Part No.	Dimension
	Male inserts for male contacts Without contacts (to be ordered separately) Male insert is protected from access with the back of the hand (IP1X or IPXXA)	CX 06P CM	

	Female inserts for female contacts Without contacts (to be ordered separately) Female insert is finger proof (IP2X or IPXXB) even if not coupled	CX 06P CF	
--	--	---------------------------	--

16 A advanced opening contacts		Male	Female	
section (mm ²)	section (AWG)			
0,5	20	CC 0.5 AN		
0,75	18	CC 0.7 AN		
1	18	CC 1.0 AN		
1,5	16	CC 1.5 AN		
2,5	14	CC 2.5 AN		
16 A crimp contacts				
section (mm ²)	section (AWG)			
0,14-0,37	26-22	CCMA 0.3	CCFA 0.3	
0,5	20	CCMA 0.5	CCFA 0.5	
0,75	18	CCMA 0.7	CCFA 0.7	
1	18	CCMA 1.0	CCFA 1.0	
1,5	16	CCMA 1.5	CCFA 1.5	
2,5	14	CCMA 2.5	CCFA 2.5	
3	12	CCMA 3.0	CCFA 3.0	
4	12	CCMA 4.0	CCFA 4.0	
		silver		
0,14-0,37	26-22	CCMD 0.3	CCFD 0.3	
0,5	20	CCMD 0.5	CCFD 0.5	
0,75	18	CCMD 0.7	CCFD 0.7	
1	18	CCMD 1.0	CCFD 1.0	
1,5	16	CCMD 1.5	CCFD 1.5	
2,5	14	CCMD 2.5	CCFD 2.5	
3	12	CCMD 3.0	CCFD 3.0	
4	12	CCMD 4.0	CCFD 4.0	
		gold		

Wiring information, CC contacts

conductor section (mm ²)	conductor slot ø A (mm)	stripping length (mm)
0,14-0,37	0,9	7,5
0,5	1,1	7,5
0,75	1,3	7,5
1,0	1,45	7,5
1,5	1,8	7,5
2,5	2,2	7,5
3,0	2,55	7,5
4,0	2,85	7,5

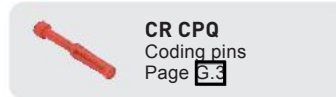
Wire diameter: up to 4,7 mm.

For basic or high thickness gold plating, please refer to page [F.13](#).

It is recommended to use the crimping tools and removal tools homologated by ILME (please see page [F.23](#))

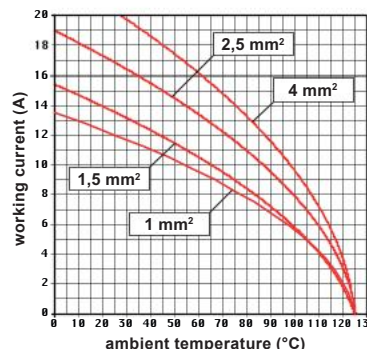
Materials

Insert	polycarbonate (PC)
UL 94 flame rating	V-0
Colour	pebble grey, RAL 7032
Contacts	copper alloy, silver ● and gold ● plated



Accessories

	Pages
MIXO Frames	
Metal frames for modular units	C.94-96
Thermoplastic docking frames	C.98-101
Enclosures	
Insulating MIXO holder	C.103
MIXO ONE	C.106-107
MIXO TWO	C.110-111



CX 06P C inserts max. current load derating diagram

It is recommended the use of **CRF CX / CRM CX** coding pins together with relevant MIXO frames.

CX 20 C

16 A 500 V

size 2 modules

20 poles

Crimp connection

EN 61984 rating	16 A 500 V 6 kV 3
	16 A 830 V 8 kV 2
Rated voltage (UL / CSA)	600 V
Insulation resistance	≥ 10 GΩ
Contact resistance	≤ 1 mΩ
Ambient temperature limit	-40 °C ... +125 °C
Mechanical life (cycles)	≥ 500

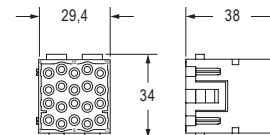
 ECBT2.E115072 | ECBT8.E115072
 PVVA2.E506437 | PVVA8.E506437

Item	Description	Part No.	Dimension
------	-------------	----------	-----------



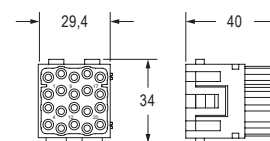
Male inserts for male contacts
 Without contacts (to be ordered separately)

[CX 20 CM](#)



Female inserts for female contacts
 Without contacts (to be ordered separately)

[CX 20 CF](#)

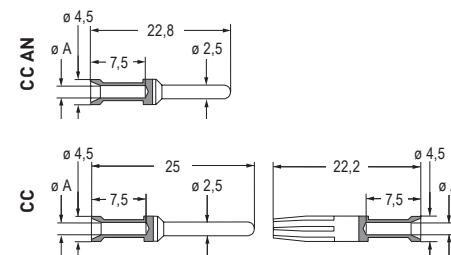


16 A advanced opening contacts

section (mm ²)	section (AWG)
0,5	20
0,75	18
1	18
1,5	16
2,5	14

Male Female

Material	Male	Female
silver	CC 0.5 AN	
	CC 0.7 AN	
	CC 1.0 AN	
	CC 1.5 AN	
	CC 2.5 AN	



16 A crimp contacts

section (mm ²)	section (AWG)
0,14-0,37	26-22
0,5	20
0,75	18
1	18
1,5	16
2,5	14
3	12
4	12

Material	Male	Female
silver	CCMA 0.3	CCFA 0.3
	CCMA 0.5	CCFA 0.5
	CCMA 0.7	CCFA 0.7
	CCMA 1.0	CCFA 1.0
	CCMA 1.5	CCFA 1.5
	CCMA 2.5	CCFA 2.5
	CCMA 3.0	CCFA 3.0
	CCMA 4.0	CCFA 4.0

Wiring information, CC contacts

conductor section (mm ²)	conductor slot ø A (mm)	stripping length (mm)
0,14-0,37	0,9	7,5
0,5	1,1	7,5
0,75	1,3	7,5
1,0	1,45	7,5
1,5	1,8	7,5
2,5	2,2	7,5
3,0	2,55	7,5
4,0	2,85	7,5

Wire diameter: up to 4,7 mm.

For basic or high thickness gold plating, please refer to page [F.13](#).

It is recommended to use the crimping tools and removal tools homologated by ILME (please see page [F.23](#)).

Materials

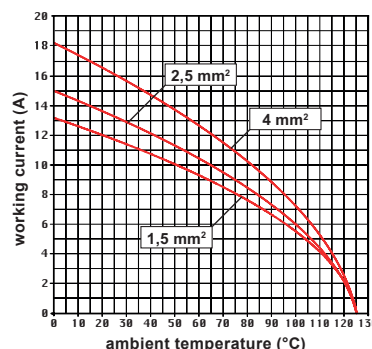
Insert	polycarbonate (PC)
UL 94 flame rating	V-0
Colour	pebble grey, RAL 7032
Contacts	copper alloy, silver ● and gold ● plated



CR CPQ
 Coding pins
 Page [G.3](#)

Accessories

Accessories	Pages
MIXO Frames	
Metal frames for modular units	C.95
Thermoplastic docking frames	C.98-101



CX 20 C inserts max. current load derating diagram

On request, version with 3 fastened [CX 20 CM/CF](#) inserts with poles numbered from 1-60 references: [CX 60 CM](#) and [CX 60 CF](#)

CX 06 C

16 A 500 V

size **1 module**

6 poles

Crimp connection

EN 61984 rating	16 A 500 V 6 kV 3
	16 A 400 / 690 V 6 kV 2
Rated voltage (UL / CSA)	600 V
Insulation resistance	≥ 10 GΩ
Contact resistance	≤ 1 mΩ
Ambient temperature limit	-40 °C ... +125 °C
Mechanical life (cycles)	≥ 500

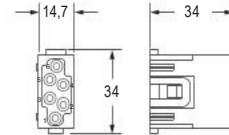


ECBT2.E115072 | ECBT8.E115072
PVVA2.E506437 | PVVA8.E506437

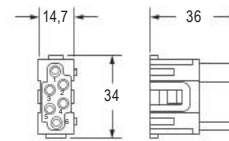
Item	Description	Part No.	Dimension
------	-------------	----------	-----------



Male inserts for male contacts [CX 06 CM](#)
Without contacts (to be ordered separately)



Female inserts for female contacts [CX 06 CF](#)
Without contacts (to be ordered separately)



16 A advanced opening contacts

section (mm ²)	section (AWG)
0,5	20
0,75	18
1	18
1,5	16
2,5	14

Male Female

- [CC 0.5 AN](#)
- [CC 0.7 AN](#)
- [CC 1.0 AN](#)
- [CC 1.5 AN](#)
- [CC 2.5 AN](#)



16 A crimp contacts

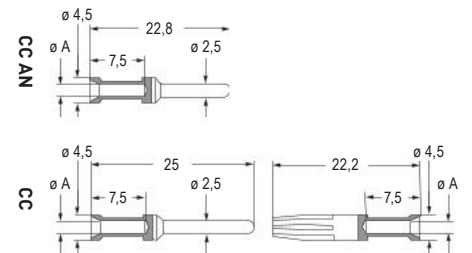
section (mm ²)	section (AWG)
0,14-0,37	26-22
0,5	20
0,75	18
1	18
1,5	16
2,5	14
3	12
4	12

- [CCMA 0.3](#) [CCFA 0.3](#)
- [CCMA 0.5](#) [CCFA 0.5](#)
- [CCMA 0.7](#) [CCFA 0.7](#)
- [CCMA 1.0](#) [CCFA 1.0](#)
- [CCMA 1.5](#) [CCFA 1.5](#)
- [CCMA 2.5](#) [CCFA 2.5](#)
- [CCMA 3.0](#) [CCFA 3.0](#)
- [CCMA 4.0](#) [CCFA 4.0](#)



section (mm ²)	section (AWG)
0,14-0,37	26-22
0,5	20
0,75	18
1	18
1,5	16
2,5	14
3	12
4	12

- [CCMD 0.3](#) [CCFD 0.3](#)
- [CCMD 0.5](#) [CCFD 0.5](#)
- [CCMD 0.7](#) [CCFD 0.7](#)
- [CCMD 1.0](#) [CCFD 1.0](#)
- [CCMD 1.5](#) [CCFD 1.5](#)
- [CCMD 2.5](#) [CCFD 2.5](#)
- [CCMD 3.0](#) [CCFD 3.0](#)
- [CCMD 4.0](#) [CCFD 4.0](#)



Wiring information, CC contacts

conductor section (mm ²)	conductor slot ø A (mm)	stripping length (mm)
0,14-0,37	0,9	7,5
0,5	1,1	7,5
0,75	1,3	7,5
1,0	1,45	7,5
1,5	1,8	7,5
2,5	2,2	7,5
3,0	2,55	7,5
4,0	2,85	7,5

Wire diameter: up to 4,7 mm.

For basic or high thickness gold plating, please refer to page [F.13](#).

It is recommended to use the crimping tools and removal tools homologated by ILME (please see page [F.23](#))

Materials

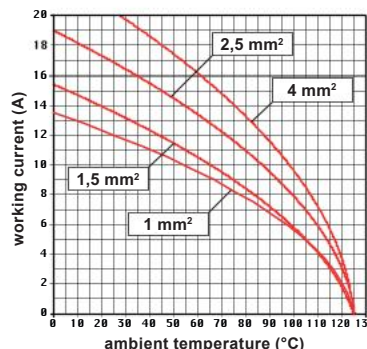
Insert	polycarbonate (PC)
UL 94 flame rating	V-0
Colour	pebble grey, RAL 7032
Contacts	copper alloy, silver ● and gold ● plated



CR CPQ
Coding pins
Page [S.3](#)

Accessories

	Pages
MIXO Frames	
Metal frames for modular units	C.94-96
Thermoplastic docking frames	C.98-101
Enclosures	
Insulating MIXO holder	C.103
MIXO ONE	C.106-107
MIXO TWO	C.110-111



CX 06 C inserts max. current load derating diagram

CX 06 CY

16 A 500 V

size **1 module**

6 poles


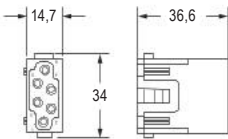

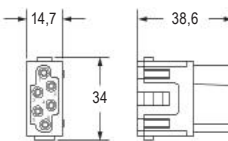
Tool-less connection – AXYR®

EN 61984 rating	16 A 500 V 6 kV 3
Rated voltage (UL / CSA)	600 V
Insulation resistance	≥ 10 GΩ
Contact resistance	≤ 3 mΩ
Ambient temperature limit	-40 °C ... +125 °C
Mechanical life (cycles)	≥ 500

CE UK (pending: EAC)

(pending: CQC, DNV and BV)

ECBT2.E115072 | ECBT8.E115072
 CULUS (pending: PVVA2.E506437 | PVVA8.E506437)

Item	Description	Part No.	Dimension
	Male inserts with male contacts Spring/AXYR® push-in connection	CX 06 CYM	
	Female inserts with female contacts Spring/AXYR® push-in connection	CX 06 CYF	

MIXO

C



Watch our clip

Materials

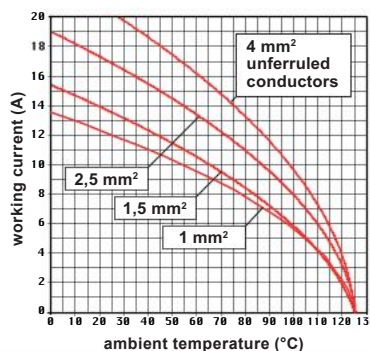
Insert	polycarbonate (PC)
UL 94 flame rating	V-0
Colour	pebble grey, RAL 7032
Contacts	built-in, copper alloy, silver ● plated

Wiring information

Wires cross sectional area	0,25 mm ² - 4 mm ² (AWG 24-12)
- unprepared	0,25 mm ² - 2,5 mm ² (AWG 24-14)
- prepared	9...11 mm
Stripping length	
Wire diameter: up to 5 mm.	

Accessories

	Pages
MIXO Frames	
Metal frames for modular units	C.94-95
Thermoplastic docking frames	C.98-101
Enclosures	
Insulating MIXO holder	C.103
MIXO ONE	C.106-107
MIXO TWO	C.110-111



CX 06 CY inserts max. current load derating diagram



CX 08 C

16 A 400 V

size **1 module**

8 poles

Crimp connection

EN 61984 rating	16 A 400 V 6 kV 3
	16 A 400 / 690 V 6 kV 2
Rated voltage (UL / CSA)	600 V
Insulation resistance	≥ 10 GΩ
Contact resistance	≤ 1 mΩ
Ambient temperature limit	-40 °C ... +125 °C
Mechanical life (cycles)	≥ 500

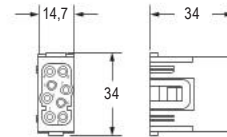


ECBT2.E115072 | ECBT8.E115072
PVVA2.E506437 | PVVA8.E506437

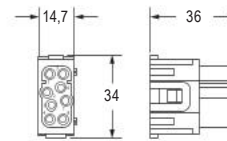
Item	Description	Part No.	Dimension
------	-------------	----------	-----------



Male inserts for male contacts [CX 08 CM](#)
Without contacts (to be ordered separately)



Female inserts for female contacts [CX 08 CF](#)
Without contacts (to be ordered separately)



16 A advanced opening contacts

section (mm ²)	section (AWG)
0,5	20
0,75	18
1	18
1,5	16
2,5	14

Male Female

- [CC 0.5 AN](#)
- [CC 0.7 AN](#)
- [CC 1.0 AN](#)
- [CC 1.5 AN](#)
- [CC 2.5 AN](#)

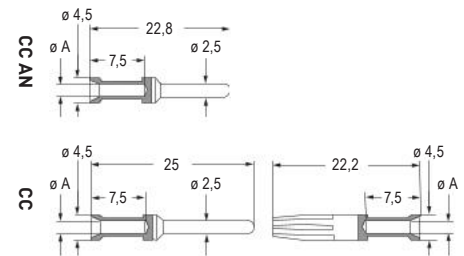
16 A crimp contacts

section (mm ²)	section (AWG)
0,14-0,37	26-22
0,5	20
0,75	18
1	18
1,5	16
2,5	14
3	12
4	12

- [CCMA 0.3](#) [CCFA 0.3](#)
- [CCMA 0.5](#) [CCFA 0.5](#)
- [CCMA 0.7](#) [CCFA 0.7](#)
- [CCMA 1.0](#) [CCFA 1.0](#)
- [CCMA 1.5](#) [CCFA 1.5](#)
- [CCMA 2.5](#) [CCFA 2.5](#)
- [CCMA 3.0](#) [CCFA 3.0](#)
- [CCMA 4.0](#) [CCFA 4.0](#)

section (mm ²)	section (AWG)
0,14-0,37	26-22
0,5	20
0,75	18
1	18
1,5	16
2,5	14
3	12
4	12

- [CCMD 0.3](#) [CCFD 0.3](#)
- [CCMD 0.5](#) [CCFD 0.5](#)
- [CCMD 0.7](#) [CCFD 0.7](#)
- [CCMD 1.0](#) [CCFD 1.0](#)
- [CCMD 1.5](#) [CCFD 1.5](#)
- [CCMD 2.5](#) [CCFD 2.5](#)
- [CCMD 3.0](#) [CCFD 3.0](#)
- [CCMD 4.0](#) [CCFD 4.0](#)



Wiring information, CC contacts

conductor section (mm ²)	conductor slot ø A (mm)	stripping length (mm)
0,14-0,37	0,9	7,5
0,5	1,1	7,5
0,75	1,3	7,5
1,0	1,45	7,5
1,5	1,8	7,5
2,5	2,2	7,5
3,0	2,55	7,5
4,0	2,85	7,5

Wire diameter: up to 4,7 mm.

For basic or high thickness gold plating, please refer to page [F.13](#).

It is recommended to use the crimping tools and removal tools homologated by ILME (please see page [F.23](#))

Materials

Insert	polycarbonate (PC)
UL 94 flame rating	V-0
Colour	pebble grey, RAL 7032
Contacts	copper alloy, silver ● and gold ● plated

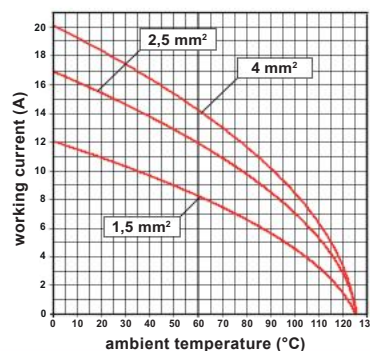


CR CPQ
Coding pins
Page [G.3](#)

Accessories

Pages

Accessories	Pages
MIXO Frames	
Metal frames for modular units	C.94-96
Thermoplastic docking frames	C.98-101
Enclosures	
Insulating MIXO holder	C.103
MIXO ONE	C.106-107
MIXO TWO	C.110-111



CX 08 C inserts max. current load derating diagram

CX 08 CY

16 A 400 V

size **1 module**

8 poles

Tool-less connection – AXYR®

EN 61984 rating	16 A 400 V 6 kV 3
Rated voltage (UL / CSA)	600 V
Insulation resistance	≥ 10 GΩ
Contact resistance	≤ 3 mΩ
Ambient temperature limit	-40 °C ... +125 °C
Mechanical life (cycles)	≥ 500

(pending: EAC)

(pending: CQC, DNV and BV)

ECBT2.E115072 | ECBT8.E115072

(pending: PVVA2.E506437 | PVVA8.E506437)

Item	Description	Part No.	Dimension
	Male inserts with male contacts Spring/AXYR® push-in connection	CX 08 CYM	
	Female inserts with female contacts Spring/AXYR® push-in connection	CX 08 CYF	

MIXO

C



Watch our clip

Materials

Insert	polycarbonate (PC)
UL 94 flame rating	V-0
Colour	pebble grey, RAL 7032
Contacts	built-in, copper alloy, silver ● plated

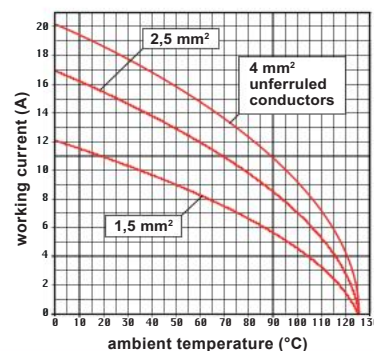
Wiring information

Wires cross sectional area	
- unprepared	0,25 mm ² - 4 mm ² (AWG 24-12)
- prepared	0,25 mm ² - 2,5 mm ² (AWG 24-14)
Stripping length	9...11 mm

Wire diameter: up to 5 mm.

Accessories

	Pages
MIXO Frames	
Metal frames for modular units	C.94-95
Thermoplastic docking frames	C.98-101
Enclosures	
Insulating MIXO holder	C.103
MIXO ONE	C.106-107
MIXO TWO	C.110-111



CX 08 CY inserts max. current load derating diagram

CX 05 SH

16 A 400 V

size **1 module**

5 poles

Tool-less connection – SQUICH®

EN 61984 rating	16 A 400 V 6 kV 3
	16 A 500 V 6 kV 2
Rated voltage (UL / CSA)	600 V
Insulation resistance	≥ 10 GΩ
Contact resistance	≤ 3 mΩ
Ambient temperature limit	-40 °C ... +125 °C
Mechanical life (cycles)	≥ 500

CE UK EAC



ECBT2.E115072 | ECBT8.E115072
PVVA2.E506437 | PVVA8.E506437

Item	Description	Part No.	Dimension
	Male inserts with male contacts Spring/SQUICH® clamp connections, with actuator button	CX 05 SHM	
	Female inserts with female contacts Spring/SQUICH® clamp connections, with actuator button	CX 05 SHF	

MIXO

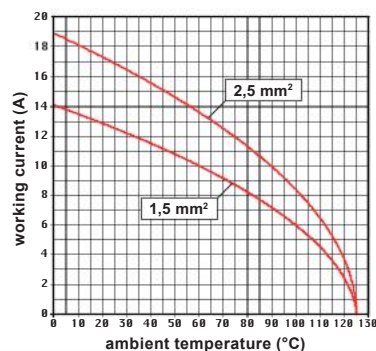
C



Watch our clip

Materials		Wiring information	
Insert	polycarbonate (PC)	Wires cross sectional area	
UL 94 flame rating	V-0	- unprepared	0,14 mm ² - 2,5 mm ² (AWG 26-14)
Colour	pebble grey, RAL 7032	- prepared	0,14 mm ² - 2,5 mm ² (AWG 26-14)
Contacts	built-in, copper alloy, silver ● plated	Stripping length	9...11 mm

Accessories	Pages
MIXO Frames	
Metal frames for modular units	C.94-98
Thermoplastic docking frames	C.98-101
Enclosures	
Insulating MIXO holder	C.103
MIXO ONE	C.106-107
MIXO TWO	C.110-111



CX 05 SH inserts max. current load derating diagram

Suitable for every conductor type (prepared with ferrule, unprepared and solid up to cross-sectional area 2,5 mm²)

CX 12 D

10 A 250 V

size 1 module

12 poles

Crimp connection

EN 61984 rating	10 A 250 V 4 kV 3
Rated voltage (UL / CSA)	600 V
Insulation resistance	≥ 10 GΩ
Contact resistance	≤ 3 mΩ
Ambient temperature limit	-40 °C ... +125 °C
Mechanical life (cycles)	≥ 500



ECBT2.E115072 | ECBT8.E115072
PVVA2.E506437 | PVVA8.E506437

Item	Description	Part No.	Dimension
	Male inserts for male contacts Without contacts (to be ordered separately)	CX 12 DM	
	Female inserts for female contacts Without contacts (to be ordered separately)	CX 12 DF	

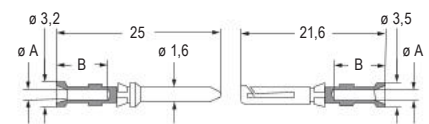
10 A crimp contacts

section (mm ²)	section (AWG)
0,14-0,37	26-22
0,5	20
0,75	18
1	18
1,5	16
2,5	14

Male Female

silver	Female
CDMA 0.3	CDFA 0.3
CDMA 0.5	CDFA 0.5
CDMA 0.7	CDFA 0.7
CDMA 1.0	CDFA 1.0
CDMA 1.5	CDFA 1.5
CDMA 2.5	CDFA 2.5

gold	Female
CDMD 0.3	CDFD 0.3
CDMD 0.5	CDFD 0.5
CDMD 0.7	CDFD 0.7
CDMD 1.0	CDFD 1.0
CDMD 1.5	CDFD 1.5
CDMD 2.5	CDFD 2.5



Wiring information, CD contacts

conductor section (mm ²)	conductor slot ø A (mm)	stripping length B (mm)
0,14-0,37	0,9	8
0,5	1,1	8
0,75	1,3	8
1,0	1,45	8
1,5	1,8	8
2,5	2,2	6

Wire diameter: up to 3,8 mm.

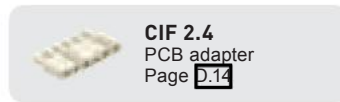
For basic or high thickness gold plating, please refer to page [E.16](#)

For stamped crimp contacts (SD series), please refer to page [E.18](#)

It is recommended to use the crimping tools and removal tools homologated by ILME (please see page [E.23](#))

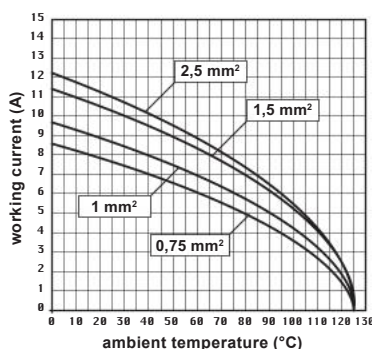
Materials

Insert	polycarbonate (PC)
UL 94 flame rating	V-0
Colour	pebble grey, RAL 7032
Contacts	copper alloy, silver ● and gold ● plated

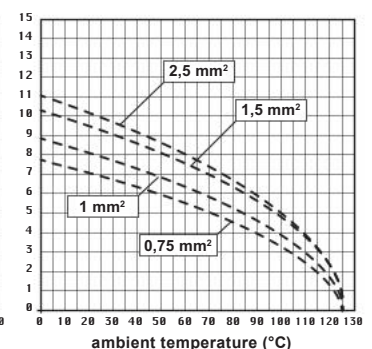


Accessories	Pages
MIXO Frames	
Metal frames for modular units	C.94-99
Thermoplastic docking frames	C.98-101
Enclosures	
Insulating MIXO holder	C.103
MIXO ONE	C.106-107
MIXO TWO	C.110-111

CX 12 D inserts max. current load derating diagram, turned contacts



CX 12 D inserts max. current load derating diagram, stamped contacts



CX 12 DY

10 A 250 V

size **1 module**

12 poles


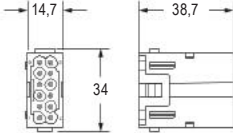

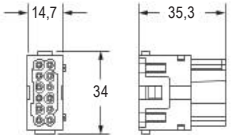
Tool-less connection – AXYR®

EN 61984 rating	10 A 250 V 4 kV 3
Rated voltage (UL / CSA)	600 V
Insulation resistance	≥ 10 GΩ
Contact resistance	≤ 3 mΩ
Ambient temperature limit	-40 °C ... +125 °C
Mechanical life (cycles)	≥ 500

CE UK (pending: EAC)

(pending: CQC, DNV and BV)

(pending: cURus)

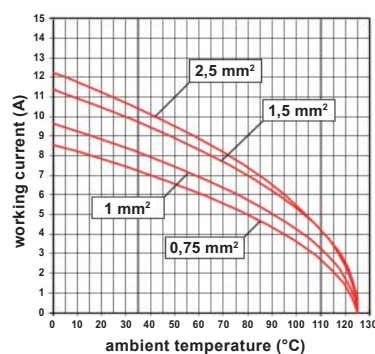
Item	Description	Part No.	Dimension
	Male inserts with male contacts Spring/AXYR® push-in connection	CX 12 DYM	
	Female inserts with female contacts Spring/AXYR® push-in connection	CX 12 DYF	



Watch our clip

Materials		Wiring information	
Insert	polycarbonate (PC)	Wires cross sectional area	
UL 94 flame rating	V-0	- unprepared	0,14 mm ² - 2,5 mm ² (AWG 26-14)
Colour	pebble grey, RAL 7032	- prepared	0,14 mm ² - 1,5 mm ² (AWG 26-16)
Contacts	built-in, copper alloy, silver ● plated	Stripping length	9...11 mm
		Wire diameter: up to 3,8 mm.	

Accessories	Pages
MIXO Frames	
Metal frames for modular units	C.94-95
Thermoplastic docking frames	C.98-101
Enclosures	
Insulating MIXO holder	C.103
MIXO ONE	C.106-107
MIXO TWO	C.110-111



CX 12 DY inserts max. current load derating diagram

CX 17 D


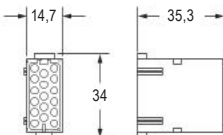

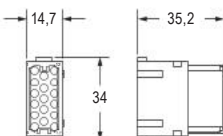
10 A 160 V

 size **1 module**
17 poles

Crimp connection

EN 61984 rating	10 A 160 V 2,5 kV 3
	10 A 250 V 4 kV 2
Rated voltage (UL / CSA)	250 V
Insulation resistance	≥ 10 GΩ
Contact resistance	≤ 3 mΩ
Ambient temperature limit	-40 °C ... +125 °C
Mechanical life (cycles)	≥ 500


 ECBT2.E115072 | ECBT8.E115072
 PVVA2.E506437 | PVVA8.E506437

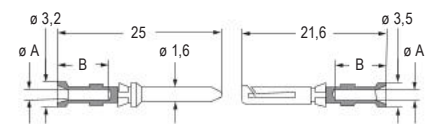
Item	Description	Part No.	Dimension
	Male inserts for male contacts Without contacts (to be ordered separately)	CX 17 DM	
	Female inserts for female contacts Without contacts (to be ordered separately)	CX 17 DF	

10 A crimp contacts

section (mm ²)	section (AWG)
0,14-0,37	26-22
0,5	20
0,75	18
1	18
1,5	16
2,5	14

Male Female

silver	CDMA 0.3	CDFA 0.3
	CDMA 0.5	CDFA 0.5
	CDMA 0.7	CDFA 0.7
	CDMA 1.0	CDFA 1.0
	CDMA 1.5	CDFA 1.5
	CDMA 2.5	CDFA 2.5
gold	CDMD 0.3	CDFD 0.3
	CDMD 0.5	CDFD 0.5
	CDMD 0.7	CDFD 0.7
	CDMD 1.0	CDFD 1.0
	CDMD 1.5	CDFD 1.5
	CDMD 2.5	CDFD 2.5



Wiring information, CD contacts

conductor section (mm ²)	conductor slot ø A (mm)	stripping length B (mm)
0,14-0,37	0,9	8
0,5	1,1	8
0,75	1,3	8
1,0	1,45	8
1,5	1,8	8
2,5	2,2	6

Wire diameter: up to 3,8 mm.


 For basic or high thickness gold plating, please refer to page [E.16](#).

 For stamped crimp contacts (SD series), please refer to page [E.18](#).

 It is recommended to use the crimping tools and removal tools homologated by ILME (please see page [E.23](#)).

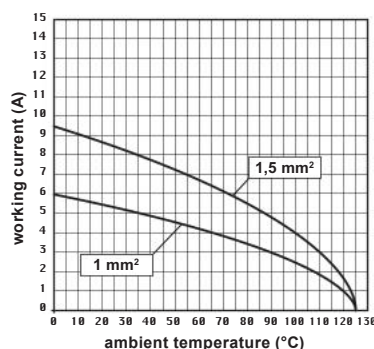
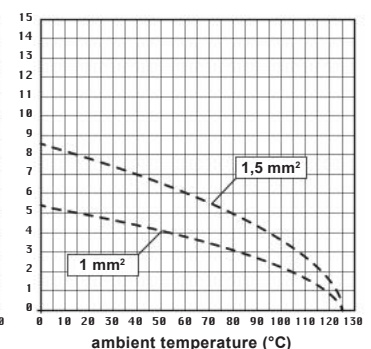
Materials

Insert	polycarbonate (PC)
UL 94 flame rating	V-0
Colour	pebble grey, RAL 7032
Contacts	copper alloy, silver ● and gold ● plated



CIF X17 2.4
PCB adapter
Page [D.14](#)

Accessories	Pages
MIXO Frames	
Metal frames for modular units	C.94-99
Thermoplastic docking frames	C.98-101
Enclosures	
Insulating MIXO holder	C.103
MIXO ONE	C.106-107
MIXO TWO	C.110-111

CX 17 D inserts max. current load derating diagram, turned contacts

CX 17 D inserts max. current load derating diagram, stamped contacts


Can be used in bulkhead mounting housings or in high construction housings or in high construction hoods.

CX 42 D

10 A 150 V

size **2 modules**

42 poles

Crimp connection

EN 61984 rating	10 A 150 V 2,5 kV 3
Rated voltage (UL / CSA)	250 V
Insulation resistance	≥ 10 GΩ
Contact resistance	≤ 3 mΩ
Ambient temperature limit	-40 °C ... +125 °C
Mechanical life (cycles)	≥ 500



ECBT2.E115072 | ECBT8.E115072
PVVA2.E506437 | PVVA8.E506437

Item	Description	Part No.	Dimension
	Male inserts for male contacts Without contacts (to be ordered separately) Supplied with 2 dedicated black coloured 2-slot sized lock-in tab. For spare lock-in tab CX CFMD see SPARE PARTS catalogue	CX 42 DM	
	Female inserts for female contacts Without contacts (to be ordered separately) Supplied with 2 dedicated black coloured 2-slot sized lock-in tab. For spare lock-in tab CX CFMD see SPARE PARTS catalogue	CX 42 DF	

10 A crimp contacts	section (mm ²)		section (AWG)		Male	Female					
	0,14-0,37	0,5	26-22	20							
	0,5	0,75	18	18	silver	CDMA 0.3 CDMA 0.5 CDMA 0.7 CDMA 1.0 CDMA 1.5 CDMA 2.5	CDFA 0.3 CDFA 0.5 CDFA 0.7 CDFA 1.0 CDFA 1.5 CDFA 2.5				
	1	1,5	18	16							
	2,5	2,5	14	14							
		0,14-0,37	0,5	26-22				20	gold	CDMD 0.3 CDMD 0.5 CDMD 0.7 CDMD 1.0 CDMD 1.5 CDMD 2.5	CDFD 0.3 CDFD 0.5 CDFD 0.7 CDFD 1.0 CDFD 1.5 CDFD 2.5
		0,75	1	18				18			
1,5		1,5	16	16							
2,5		2,5	14	14							

Wiring information, CD contacts

conductor section (mm ²)	conductor slot ø A (mm)	stripping length B (mm)
0,14-0,37	0,9	8
0,5	1,1	8
0,75	1,3	8
1,0	1,45	8
1,5	1,8	8
2,5	2,2	6

Wire diameter: up to 3,6 mm.

For basic or high thickness gold plating, please refer to page [E.16](#)

For stamped crimp contacts (SD series), please refer to page [E.18](#)

It is recommended to use the crimping tools and removal tools homologated by ILME (please see page [E.23](#))

Materials

Insert	polycarbonate (PC)
UL 94 flame rating	V-0
Colour	pebble grey, RAL 7032
Contacts	copper alloy, silver ● and gold ● plated

Accessories

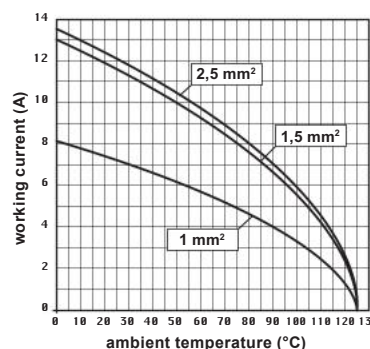
Pages

MIXO Frames

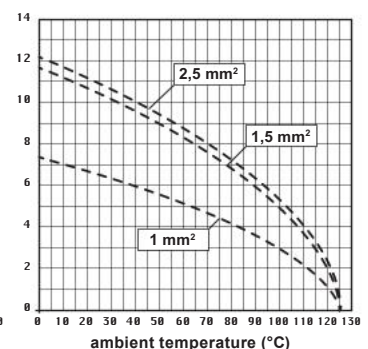
Metal frames for modular units

[C.95](#)

CX 42 D inserts max. current load derating diagram, turned contacts



CX 42 D inserts max. current load derating diagram, stamped contacts



Can be used in bulkhead mounting housings or in high construction housings or in high construction hoods.

CX 25 IB

4 A 50 V

size **1 module**


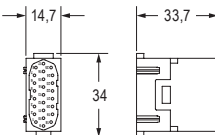
25 poles

Crimp connection

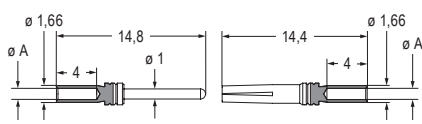







EN 61984 rating	4 A 50 V 0,8 kV 3
	4 A 160 V 2,5 kV 2
Rated voltage (UL / CSA)	600 V
Insulation resistance	≥ 10 GΩ
Contact resistance	≤ 4 mΩ
Ambient temperature limit	-40 °C ... +125 °C
Mechanical life (cycles)	≥ 500



ECBT2.E115072 | ECBT8.E115072
PVVA2.E506437 | PVVA8.E506437

Item	Description	Part No.	Dimension
	Male inserts for male contacts Without contacts (to be ordered separately)	CX 25 IBM	

	Female inserts for female contacts Without contacts (to be ordered separately)	CX 25 IBF	
---	---	---------------------------	---

5 A crimp contacts	section (mm ²)		section (AWG)		Male	Female	
		0,08-0,21	0,13-0,33	28-24	26-22		
	0,33-0,52	0,52-0,75	22-20	20-18			
	0,08-0,21	0,13-0,33	28-24	26-22			
	0,33-0,52	0,52-0,75	22-20	20-18			

Wiring information, CI contacts

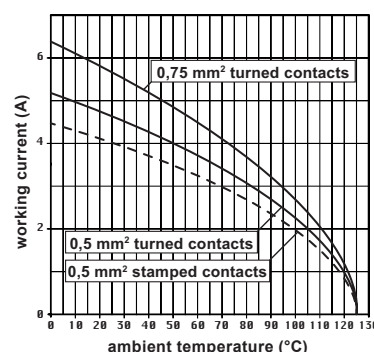
conductor section (mm ²)	conductor slot ø A (mm)	stripping length (mm)
0,08-0,21	0,64	4
0,13-0,33	0,9	4
0,33-0,52	1,12	4
0,52-0,75	1,30	4

Wire diameter: up to 2,1 mm.
For basic or high thickness gold plating, please refer to page [F.17](#).
For stamped crimp contacts (SI series), please refer to page [F.19](#).
It is recommended to use the crimping tools and removal tools homologated by ILME (please see page [F.23](#)).

Materials

Insert	polycarbonate (PC)
UL 94 flame rating	V-0
Colour	pebble grey, RAL 7032
Contacts	copper alloy, silver ● and gold ● plated

Accessories	Pages
MIXO Frames	
Metal frames for modular units	C.94-95
Thermoplastic docking frames	C.98-101
Enclosures	
Insulating MIXO holder	C.103
MIXO ONE	C.106-107
MIXO TWO	C.110-111



CX 25 IB inserts max. current load derating diagram

It is recommended the use of **CRF CX / CRM CX** coding pins together with relevant MIXO frames.

CX 36 I

4 A 32 V

size **1 module**


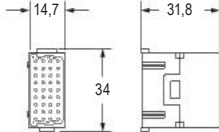

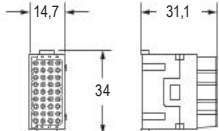

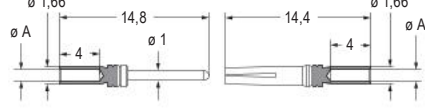
36 poles

Crimp connection

EN 61984 rating	4 A 32 V 0,8 kV 3
Rated voltage (UL / CSA)	30 V
Insulation resistance	≥ 10 GΩ
Contact resistance	≤ 4 mΩ
Ambient temperature limit	-40 °C ... +125 °C
Mechanical life (cycles)	≥ 500



ALUS ECBT2.E115072 | ECBT8.E115072

Item	Description	Part No.	Dimension
	Male inserts for male contacts Without contacts (to be ordered separately)	CX 36 IM	
	Female inserts for female contacts Without contacts (to be ordered separately)	CX 36 IF	
	5 A crimp contacts section (mm ²) section (AWG)	Male Female	
	0,08-0,21 28-24	silver CIMA 0.2 CIFA 0.2	
	0,13-0,33 26-22	CIMA 0.3 CIFA 0.3	
	0,33-0,52 22-20	CIMA 0.5 CIFA 0.5	
	0,08-0,21 28-24	gold CIMD 0.2 CIFD 0.2	
	0,13-0,33 26-22	CIMD 0.3 CIFD 0.3	
	0,33-0,52 22-20	CIMD 0.5 CIFD 0.5	

Wiring information, CI contacts

conductor section (mm ²)	conductor slot ø A (mm)	stripping length (mm)
0,08-0,21	0,64	4
0,13-0,33	0,9	4
0,33-0,52	1,12	4

Wire diameter: up to 1,7 mm.

For basic or high thickness gold plating, please refer to page [F.17](#).

For stamped crimp contacts (SI series), please refer to page [F.19](#).

It is recommended to use the crimping tools and removal tools homologated by ILME (please see page [E.23](#)).

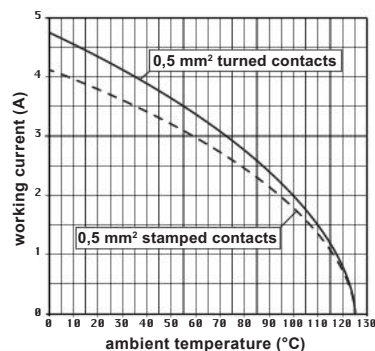
Materials

Insert	polycarbonate (PC)
UL 94 flame rating	V-0
Colour	pebble grey, RAL 7032
Contacts	copper alloy, silver ● and gold ● plated

Accessories

Pages

Accessories	Pages
MIXO Frames	
Metal frames for modular units	C.94-96
Thermoplastic docking frames	C.98-101
Enclosures	
Insulating MIXO holder	C.103
MIXO ONE	C.106-107
MIXO TWO	C.110-111



CX 36 I inserts max. current load derating diagram

CX 02 4H

40 A 2900/5000 V

size **2 module**


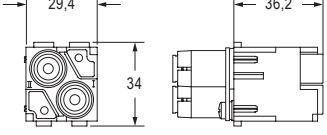

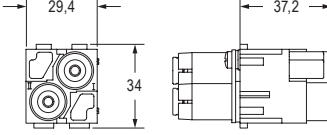

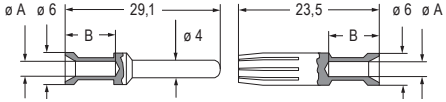
2 poles

Crimp connection

EN 61984 rating	40 A 2900 / 5000 V 15 kV 3
Rated voltage (UL / CSA)	5000 V
Insulation resistance	≥ 10 GΩ
Contact resistance	≤ 0,3 mΩ
Ambient temperature limit	-40 °C ... +125 °C
Mechanical life (cycles)	≥ 500



ILME ECBT2.E115072 | ECBT8.E115072

Item	Description	Part No.	Dimension
	High voltage male inserts for male contacts Without contacts (to be ordered separately) Supplied with heat-shrinking insulating tube for the rear of the contacts	CX 02 4HM	
	High voltage female inserts for female contacts Without contacts (to be ordered separately) Supplied with heat-shrinking insulating tube for the rear of the contacts	CX 02 4HF	
	40 A crimp contacts section (mm ²) section (AWG)	Male CXMA 1.5 CXMA 2.5 CXMA 4.0 CXMA 6.0 CXMA 10	Female CXFA 1.5 CXFA 2.5 CXFA 4.0 CXFA 6.0 CXFA 10
		silver	

Wiring information, CX contacts

conductor section (mm ²)	conductor slot ø A (mm)	stripping length B (mm)
1,5	1,8	9
2,5	2,2	9
4	2,85	9,6
6	3,5	9,6
10	4,3	15

Wire diameter: up to 7 mm

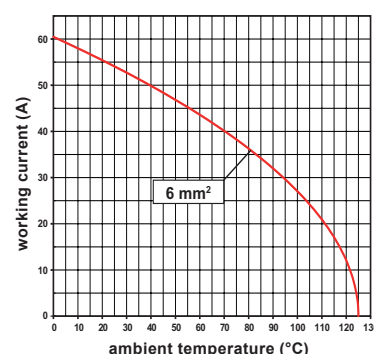
It is recommended to use the crimping tools and removal tools homologated by ILME (please see page [E.23](#))

Materials

Insert	polycarbonate (PC)
UL 94 flame rating	V-0
Colour	pebble grey, RAL 7032
Contacts	copper alloy, silver ● plated

Accessories

Accessories	Pages
MIXO Frames	
Metal frames for modular units	C.95
Thermoplastic docking frames	C.98-101



CX 02 4H inserts max. current load derating diagram

Can be used in bulkhead mounting housings or in high construction housings or in high construction hoods.

CX 02 H

16 A 2900/5000 V

size **2 modules**


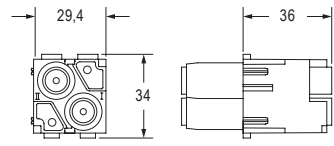
2 poles


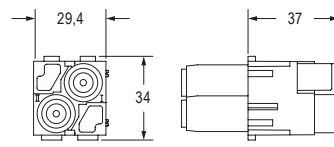
Crimp connection

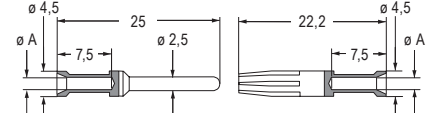
EN 61984 rating	16 A 2900 / 5000 V 15 kV 3
Rated voltage (UL / CSA)	5000 V
Insulation resistance	≥ 10 GΩ
Contact resistance	≤ 1 mΩ
Ambient temperature limit	-40 °C ... +125 °C
Mechanical life (cycles)	≥ 500



ILME ECBT2.E115072 | ECBT8.E115072

Item	Description	Part No.	Dimension
	High voltage male inserts for male contacts Without contacts (to be ordered separately) Supplied with heat-shrinking insulating tube for the rear of the contacts	CX 02 HM	

	High voltage female inserts for female contacts Without contacts (to be ordered separately) Supplied with heat-shrinking insulating tube for the rear of the contacts	CX 02 HF	
--	---	--------------------------	---

16 A crimp contacts		Male	Female	
section (mm ²)	section (AWG)			
0,5	20	silver	CCMA 0.5	CCFA 0.5
0,75	18		CCMA 0.7	CCFA 0.7
1	18		CCMA 1.0	CCFA 1.0
1,5	16		CCMA 1.5	CCFA 1.5
2,5	14		CCMA 2.5	CCFA 2.5
3	12		CCMA 3.0	CCFA 3.0
4	12	CCMA 4.0	CCFA 4.0	
0,5	20	gold	CCMD 0.5	CCFD 0.5
0,75	18		CCMD 0.7	CCFD 0.7
1	18		CCMD 1.0	CCFD 1.0
1,5	16		CCMD 1.5	CCFD 1.5
2,5	14		CCMD 2.5	CCFD 2.5
3	12		CCMD 3.0	CCFD 3.0
4	12	CCMD 4.0	CCFD 4.0	

Wiring information, CC contacts

conductor section (mm ²)	conductor slot ø A (mm)	stripping length (mm)
0,5	1,1	9,5
0,75	1,3	9,5
1,0	1,45	9,5
1,5	1,8	9,5
2,5	2,2	9,5
3,0	2,55	9,5
4,0	2,85	9,5

Wire diameter: up to 4,7 mm.

For basic or high thickness gold plating, please refer to page [F.13](#).

It is recommended to use the crimping tools and removal tools homologated by ILME (please see page [F.23](#))

Materials

Insert	polycarbonate (PC)
UL 94 flame rating	V-0
Colour	pebble grey, RAL 7032
Contacts	copper alloy, silver ● and gold ● plated

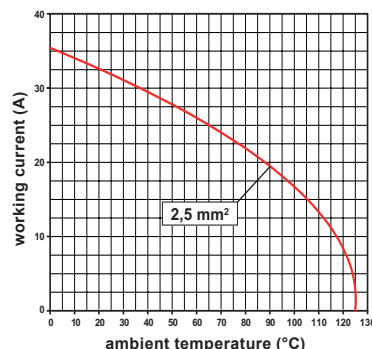
Accessories

Pages

MIXO Frames

Metal frames for modular units	C.95
Thermoplastic docking frames	C.98-101

Can be used in bulkhead mounting housings or in high construction housings or in high construction hoods.



CX 02 H inserts max. current load derating diagram

CX 02 CH

16 A 2500 V

size **1 module**


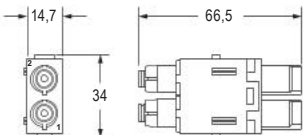
2 poles

Crimp connection

EN 61984 rating	16 A 2500 V 15 kV 3
Rated voltage (UL / CSA)	2500 V
Insulation resistance	≥ 10 GΩ
Contact resistance	≤ 1 mΩ
Ambient temperature limit	-40 °C ... +125 °C
Mechanical life (cycles)	≥ 500



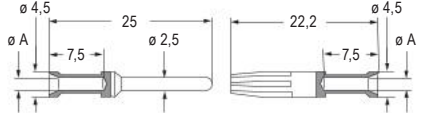
CBUS ECBT2.E115072 | ECBT8.E115072

Item	Description	Part No.	Dimension
	High voltage male inserts for male contacts Without contacts (to be ordered separately) Supplied with heat-shrinking insulating tube for the rear of the contacts	CX 02 CHM	

	High voltage female inserts for female contacts Without contacts (to be ordered separately) Supplied with heat-shrinking insulating tube for the rear of the contacts	CX 02 CHF	
---	---	---------------------------	---

MIXO

C

16 A crimp contacts		Male	Female	
section (mm ²)	section (AWG)			
0,5	20	CCMA 0.5	CCFA 0.5	
0,75	18	CCMA 0.7	CCFA 0.7	
1	18	CCMA 1.0	CCFA 1.0	
1,5	16	CCMA 1.5	CCFA 1.5	
2,5	14	CCMA 2.5	CCFA 2.5	
3	12	CCMA 3.0	CCFA 3.0	
4	12	CCMA 4.0	CCFA 4.0	
		silver		
0,5	20	CCMD 0.5	CCFD 0.5	
0,75	18	CCMD 0.7	CCFD 0.7	
1	18	CCMD 1.0	CCFD 1.0	
1,5	16	CCMD 1.5	CCFD 1.5	
2,5	14	CCMD 2.5	CCFD 2.5	
3	12	CCMD 3.0	CCFD 3.0	
4	12	CCMD 4.0	CCFD 4.0	
		gold		

Wiring information, CC contacts

conductor section (mm ²)	conductor slot ø A (mm)	stripping length (mm)
0,5	1,1	9,5
0,75	1,3	9,5
1,0	1,45	9,5
1,5	1,8	9,5
2,5	2,2	9,5
3,0	2,55	9,5
4,0	2,85	9,5

Wire diameter: up to 4,7 mm.

For basic or high thickness gold plating, please refer to page [F.13](#)

It is recommended to use the crimping tools and removal tools homologated by ILME (please see page [F.23](#))

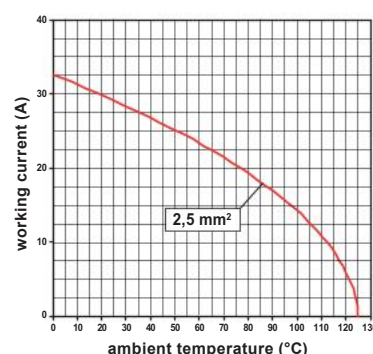
Materials

Insert	polycarbonate (PC)
UL 94 flame rating	V-0
Colour	pebble grey, RAL 7032
Contacts	copper alloy, silver ● and gold ● plated



Tutorial

Accessories	Pages
MIXO Frames	
Metal frames for modular units	C.94-95
Thermoplastic docking frames	C.98-101
Enclosures	
Insulating MIXO holder	C.103
MIXO ONE	C.106-107
MIXO TWO	C.110-111



CX 02 CH inserts max. current load derating diagram

Can be used in bulkhead mounting housings or in high construction housings or in high construction hoods.



MIXO Shielded & MIXO BUS modules



The MIXO Shielded and MIXO BUS series offer a selection of modules and contacts designed for applications requiring high interface robustness and reliable data transmission.

They complement the MIXO product range with compatible connectors for Megabit and Gigabit Ethernet, Cat 5e and Cat 6A, and data BUS signals.

MIXO CX 08 D5 Megabit

Fully shielded 8-pole connector module for series CD 10 A crimp contact, designed for data transmission, Megabit Ethernet Cat. 5e, Class D, frequencies up to 100 MHz, and data rate up to 100 Mbit/s. Available with single cable entry or double cable entry:

- > **CX 08 D5F /M** for 1 × 4-pair + shield data cable (2 × 4 conductors + shield)
- > **CX 08 D5F2 /M2** for or 2 × 2-pair shield data cable (2 × 2 × 2 conductors + shield)

The MIXO Megabit may replace the previously available MIXO BUS 2× solution (CX 02 BF /BM plus 2× shielded circular insert CX 04 BF /BM) in half space.



MIXO CX 08 I6 Gigabit

Fully shielded 8-pole connector module for series CI 5 A crimp contact, designed for data transmission, Gigabit Ethernet Cat. 6A, Class EA, frequencies up to 500 MHz, and data rate up to 10 Gbit/s.



MIXO CX 20S I shielded

This shielded module is for up to 20 turned crimp contacts series CI (5 A) sizes 0.2 to 0.5.

It protects sensitive signals against possible interference from adjacent power contacts when combined with MIXO power modules (10 A, 16 A, 40 A or more) whose wires belong to the same power/signal combined cable.



FOCUS

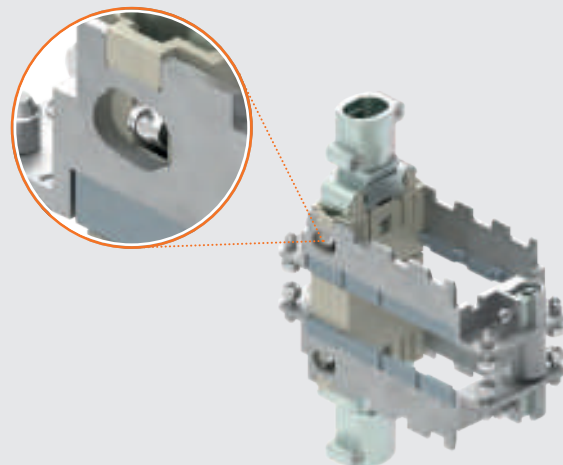
Modules with shield connection to the frame

The MIXO Gigabit, Megabit and Shielded modules are provided with a shield separated from the PE circuit.

Whereas it is common practice to keep separate the shielding potential of a data line from that of the PE protective earthing, in order not to establish ground loops that could yield undesired interference on the signals shielded by the cable screen and the connector shield, specific applications require explicit equipotential bonding between the shield and the connected screen of the incoming data cables and the PE potential established by the relevant PE terminals on the MIXO frame.

This feature is available through special versions of MIXO Gigabit, Megabit, and Shielded modules.

Part numbers with additional PE contacts are identified by the letter "G".



CX 08 D5 / CX 08 D5G

10 A 50 V

size **1 module**

8 poles + shield connection

Crimp connection

EN 61984 rating	10 A 50 V 0,8 kV 3
Rated voltage (UL / CSA)	50 V
Insulation resistance	≥ 10 GΩ
Contact resistance	≤ 3 mΩ
Ambient temperature limit	-40 °C ... +85 °C
Mechanical life (cycles)	≥ 500



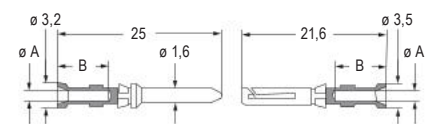
ILME® ECBT2.E115072 | ECBT8.E115072

Item	Description	Part No.	Dimension
	Male inserts, single cable entry Male inserts, double cable entry (contacts to be ordered separately) Shield electrically separated from PE circuit MIXO frame	CX 08 D5M CX 08 D5M2	
	Female inserts, single cable entry Female inserts, double cable entry (contacts to be ordered separately) Shield electrically separated from PE circuit MIXO frame	CX 08 D5F CX 08 D5F2	
	Male inserts, single cable entry Male inserts, double cable entry (contacts to be ordered separately) Shield electrically in contact with PE circuit MIXO frame by dual stainless steel springs on the insert	CX 08 D5GM CX 08 D5GM2	
	Female inserts, single cable entry Female inserts, double cable entry (contacts to be ordered separately) Shield electrically in contact with PE circuit MIXO frame by dual stainless steel springs on the insert	CX 08 D5GF CX 08 D5GF2	

10 A crimp contacts

section (mm ²)	section (AWG)
0,14-0,37	26-22
0,5	20
0,75	18
1	18
1,5	16
2,5	14

	Male	Female
gold	CDMD 0.3	CDFD 0.3
	CDMD 0.5	CDFD 0.5
	CDMD 0.7	CDFD 0.7
	CDMD 1.0	CDFD 1.0
	CDMD 1.5	CDFD 1.5
	CDMD 2.5	CDFD 2.5



Wiring information, CD contacts

conductor section (mm ²)	conductor slot ø A (mm)	stripping length B (mm)
0,14-0,37	0,9	8
0,5	1,1	8
0,75	1,3	8
1,0	1,45	8
1,5	1,8	8
2,5	2,2	6

Wire diameter: up to 3,8 mm.
For basic or high thickness gold plating, please refer to page [E.14](#).
It is recommended to use the crimping tools and removal tools homologated by ILME (please see page [E.23](#)).

Materials

Insert	polycarbonate (PC), zinc-alloy shield
UL 94 flame rating	V-0
Colour	pebble grey, RAL 7032
Contacts	copper alloy, gold ● plated

Accessories

Accessories	Pages
MIXO Frames	
Metal frames for modular units	C.94-95
Thermoplastic docking frames	C.98-101
Enclosures	
Insulating MIXO holder	C.103
MIXO ONE	C.106-107

CX..CA Cable clamps Page C.61	CX..CF Crimp flanges (1) Page C.28	CX..S Crimp sleeves (1) Page C.29
--	---	--

(1) Upon request we can supply crimp flanges (code **CX..CF**) and crimp sleeves (code **CX..S**) of different diameters that must be chosen according to the specific cable shield and insulation diameter. Please contact ILME Commercial Offices.

Megabit Ethernet Cat 5, Class D up to 100 Mhz and up to 100 Mbit/s.

It is recommended the use of **CRF CX / CRM CX** coding pins together with relevant MIXO frames.

CX 08 I6 / CX 08 I6G

5 A 50 V

size **1 module**
8 poles + shield connection

Crimp connection

EN 61984 rating	5 A 50 V 0,8 kV 3
Rated voltage (UL / CSA)	50 V
Insulation resistance	≥ 10 GΩ
Contact resistance	≤ 4 mΩ
Ambient temperature limit	-40 °C ... +85 °C
Mechanical life (cycles)	≥ 500



ILME ECBT2.E115072 | ECBT8.E115072

Item	Description	Part No.	Dimension	
	Male inserts for male contacts Without contacts (to be ordered separately) Shield electrically separated from PE circuit MIXO frame	CX 08 I6M		
	Female inserts for female contacts Without contacts (to be ordered separately) Shield electrically separated from PE circuit MIXO frame	CX 08 I6F		
	Male inserts for male contacts Without contacts (to be ordered separately) Shield electrically in contact with PE circuit MIXO frame by dual stainless steel springs on the insert	CX 08 I6GM		
	Female inserts for female contacts Without contacts (to be ordered separately) Shield electrically in contact with PE circuit MIXO frame by dual stainless steel springs on the insert	CX 08 I6GF		
	5 A crimp contacts section (mm ²) section (AWG) 0,08-0,21 28-24 0,13-0,33 26-22 0,33-0,52 22-20	Male CIMD 0.2 CIMD 0.3 CIMD 0.5	Female CIFD 0.2 CIFD 0.3 CIFD 0.5	

Wiring information, CI contacts

conductor section (mm ²)	conductor slot ø A (mm)	stripping length (mm)
0,08-0,21	0,64	4
0,13-0,33	0,9	4
0,33-0,52	1,12	4

Wire diameter: up to 1,7 mm.

For basic or high thickness gold plating, please refer to page [F.17](#)

It is recommended to use the crimping tools and removal tools homologated by ILME (please see page [F.23](#))

Materials

Insert	polycarbonate (PC), zinc-alloy shield
UL 94 flame rating	V-0
Colour	pebble grey, RAL 7032
Contacts	copper alloy, gold ● plated

Accessories

Pages

Accessories	Pages
MIXO Frames	
Metal frames for modular units	C.94-95
Thermoplastic docking frames	C.98-101
Enclosures	
Insulating MIXO holder	C.103
MIXO ONE	C.106-107
MIXO TWO	C.110-111

	CX..CA Cable clamps Page C.61		CX..CF Crimp flanges (1) Page C.28		CX..S Crimp sleeves (1) Page C.29
--	--	--	---	--	--

(1) Upon request we can supply crimp flanges (code CX..CF) and crimp sleeves (code CX..S) of different diameters that must be chosen according to the specific cable shield and insulation diameter. Please contact ILME Commercial Offices.

Gigabit Ethernet Cat 6_A, Class E_A up to 500 Mhz and up to 10 Gbit/s.

It is recommended the use of **CRF CX / CRM CX** coding pins together with relevant MIXO frames.



Tutorial

Can be used in bulkhead mounting housings or in high construction housings or in high construction hoods.

CX 20S I / CX 20S IG

4 A 32 V

 size **1 module**
20 poles + shield connection

Crimp connection

EN 61984 rating	4 A 32 V 0,8 kV 3
Rated voltage (UL / CSA)	32 V
Insulation resistance	≥ 10 GΩ
Contact resistance	≤ 4 mΩ
Ambient temperature limit	-40 °C ... +85 °C
Mechanical life (cycles)	≥ 500



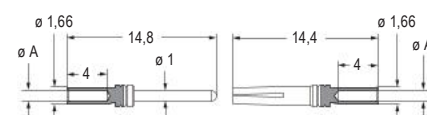
ECBT2.E115072 | ECBT8.E115072

Item	Description	Part No.	Dimension
	Male inserts for male contacts Without contacts (to be ordered separately) Shield electrically separated from PE circuit MIXO frame	CX 20S IM	
	Female inserts for female contacts Without contacts (to be ordered separately) Shield electrically separated from PE circuit MIXO frame	CX 20S IF	
	Male inserts for male contacts Without contacts (to be ordered separately) Shield electrically in contact with PE circuit MIXO frame by dual stainless steel springs on the insert	CX 20S IGM	
	Female inserts for female contacts Without contacts (to be ordered separately) Shield electrically in contact with PE circuit MIXO frame by dual stainless steel springs on the insert	CX 20S IGF	



5 A crimp contacts	
section (mm ²)	section (AWG)
0,08-0,21	28-24
0,13-0,33	26-22
0,33-0,52	22-20

	Male	Female
gold	CIMD 0.2	CIFD 0.2
	CIMD 0.3	CIFD 0.3
	CIMD 0.5	CIFD 0.5



Wiring information, CI contacts

conductor section (mm ²)	conductor slot ø A (mm)	stripping length (mm)
0,08-0,21	0,64	4
0,13-0,33	0,9	4
0,33-0,52	1,12	4

Wire diameter: up to 1,9 mm.

 For basic or high thickness gold plating, please refer to page [F.17](#)

 It is recommended to use the crimping tools and removal tools homologated by ILME (please see page [F.23](#))

Materials

Insert	polycarbonate (PC), zinc-alloy shield
UL 94 flame rating	V-0
Colour	pebble grey, RAL 7032
Contacts	copper alloy, gold plated

Accessories

Accessories	Pages
MIXO Frames	
Metal frames for modular units	C.94-95
Thermoplastic docking frames	C.98-101
Enclosures	
Insulating MIXO holder	C.103
MIXO ONE	C.106-107
MIXO TWO	C.110-111


CX..CA
 Cable clamps
 Page [C.61](#)

CX..CF
 Crimp flanges (1)
 Page [C.28](#)


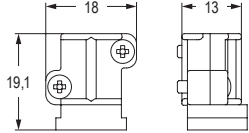

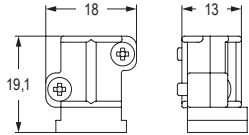

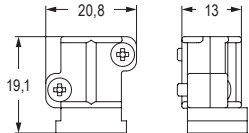

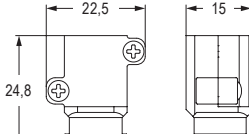
CX..S
 Crimp sleeves (1)
 Page [C.29](#)

 (1) Upon request we can supply crimp flanges (code **CX..CF**) and crimp sleeves (code **CX..S**) of different diameters that must be chosen according to the specific cable shield and insulation diameter. Please contact ILME Commercial Offices.

 It is recommended the use of **CRF CX / CRM CX** coding pins together with relevant MIXO frames.

CX..CA

Cable clamps for MIXO Megabit / Gigabit / Shielded

Item	Description	Part No.	Dimension
	Cable clamp for 5-7 mm cable diameter Crimp flanges and sleeves supplied upon request	CX 5/7 CA	
	Cable clamp for 7-10 mm cable diameter Crimp flanges and sleeves supplied upon request	CX 7/10 CA	
	Cable clamp for 10-12 mm cable diameter Can't be used with CX 08 D5F/M2/D5GF/M2 and RX 08 D5F/M2/D5GF/M2 HNM modular units. Crimp flanges and sleeves supplied upon request	CX 10/12 CA	
	Cable clamp for 11-14 mm cable diameter Can't be used with CX 08 D5F/M2/D5GF/M2 and RX 08 D5F/M2/D5GF/M2 HNM modular units. Crimp flanges and sleeves supplied upon request	CX 11/14 CA	

CX 02 B

2 seats for connectors

 size **2 modules**

EN 61984 rating	50 V 0,8 kV 3
Rated voltage (UL / CSA)	50 V
Insulation resistance	≥ 10 GΩ
Ambient temperature limit	-40 °C ... +125 °C



ECBT2.E115072 | ECBT8.E115072

Item	Description	Part No.	Dimension
	2-seat holder for shielded connectors Male inserts, two seats for BUS connectors	CX 02 BM	
	2-seat holder for shielded connectors Female inserts, two seats for BUS connectors	CX 02 BF	
	Earthing adapter (optional)	CR GND	



Tutorial

Materials

Insert	polycarbonate (PC)
UL 94 flame rating	V-0
Colour	pebble grey, RAL 7032

Female and male shielded connectors fit both in female and in male holder/adapter insert.

Suitable to hold in place any combination of up to two shielded connectors

CX 01 BC, CX 01 B, CX 04 B or CX 08 B.

Both the female and the male inserts may accept a combination of up to two shielded connectors of any gender, as far as the correct specular assignment is set on the mating connector.

Extraction tool for BUS shielded connectors from MIXO BUS insert, see **CX BES**.

The shielded connectors have their shield insulated from the enclosure's earthing point.

If you wish to earth-connect the shield, install on the panel an anchorage for shielded cables **CR..ST** or the **CR GND** earthing adapter.

Accessories

MIXO Frames

Accessories	Pages
Metal frames for modular units	C.98
Thermoplastic docking frames	C.98-101

Can be used in bulkhead mounting housings or in high construction housings or in high construction hoods.

CX 01 BC

16 A 50 V


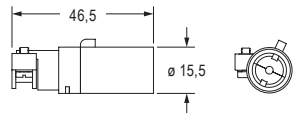
1 pole + shield


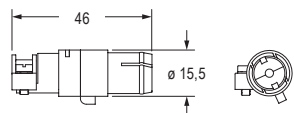
Crimp connection

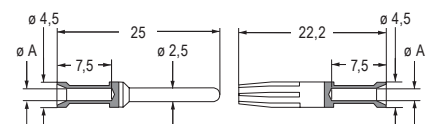
EN 61984 rating	16 A 50 V 0,8 kV 3
Rated voltage (UL / CSA)	50 V
Insulation resistance	≥ 10 GΩ
Contact resistance	≤ 1 mΩ
Ambient temperature limit	-40 °C ... +70 °C
Mechanical life (cycles)	≥ 500



CALUS ECBT2.E115072 | ECBT8.E115072

Item	Description	Part No.	Dimension
	Male inserts, one contact seat Shielded BUS coaxial 2 cable clamp included in the package	CX 01 BCM	

	Female inserts, one contact seat Shielded BUS coaxial 2 cable clamp included in the package	CX 01 BCF	
--	---	---------------------------	---

16 A crimp contacts		Male	Female	
section (mm ²)	section (AWG)			
0,14-0,37	26-22	CCMA 0.3	CCFA 0.3	
0,5	20	CCMA 0.5	CCFA 0.5	
0,75	18	CCMA 0.7	CCFA 0.7	
1	18	CCMA 1.0	CCFA 1.0	
1,5	16	CCMA 1.5	CCFA 1.5	
2,5	14	CCMA 2.5	CCFA 2.5	
3	12	CCMA 3.0	CCFA 3.0	
4	12	CCMA 4.0	CCFA 4.0	
		silver		
0,14-0,37	26-22	CCMD 0.3	CCFD 0.3	
0,5	20	CCMD 0.5	CCFD 0.5	
0,75	18	CCMD 0.7	CCFD 0.7	
1	18	CCMD 1.0	CCFD 1.0	
1,5	16	CCMD 1.5	CCFD 1.5	
2,5	14	CCMD 2.5	CCFD 2.5	
3	12	CCMD 3.0	CCFD 3.0	
4	12	CCMD 4.0	CCFD 4.0	
		pl06		

Wiring information, CC contacts

conductor section (mm ²)	conductor slot ø A (mm)	stripping length (mm)
0,14-0,37	0,9	7,5
0,5	1,1	7,5
0,75	1,3	7,5
1,0	1,45	7,5
1,5	1,8	7,5
2,5	2,2	7,5
3,0	2,55	7,5
4,0	2,85	7,5

Wire diameter: up to 4,7 mm.

For basic or high thickness gold plating, please refer to page F.13.

It is recommended to use the crimping tools and removal tools homologated by ILME (please see page F.23)

Materials

Insert	polycarbonate (PC), zinc-alloy shield
UL 94 flame rating	V-0
Colour (contacts holder)	pebble grey, RAL 7032
Contacts	copper alloy, silver ● and gold ● plated

CX 01 BC shielded connector for cable with a typical impedance of 50 Ω (attenuation see below).



CX 02 B
MIXO insert
Page C.62

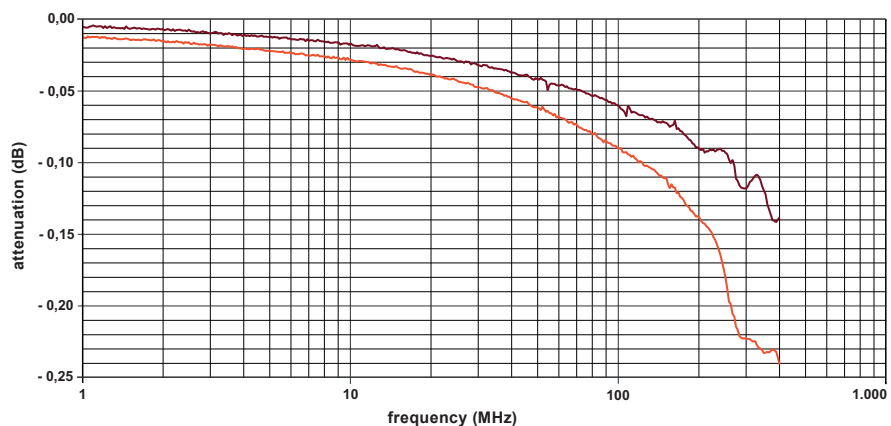


CX 1/2 BD
21.21 insert
Page A.37

Test performed in accordance with IEC/EN 60512-25-2 (2002), 4.1.3.2 (coaxial cable only) and 4.2.2.2 (coaxial cable and connector).

Attenuation (insertion loss) 50 Ω coaxial connector (CX 01 BC)

- RG 213/U cable and CX 01 BC connector (50 Ω)
- RG 213/U cable (50 Ω)



CX 01 B / CX 04 B

10 A 50 V

1 pole + shield
4 poles + shield

Crimp connection

EN 61984 rating	10 A 50 V 0,8 kV 3
Rated voltage (UL / CSA)	50 V
Insulation resistance	≥ 10 GΩ
Contact resistance	CX 01 B ≤ 3 mΩ CX 04 B ≤ 3 mΩ
Ambient temperature limit	-40 °C ... +85 °C
Mechanical life (cycles)	≥ 500



ILME® ECBT2.E115072 | ECBT8.E115072

Item	Description	Part No.	Dimension
	Male inserts, 1 contact seat Shielded BUS coaxial	CX 01 BM	 46,5 ø 15,5
	Male inserts, 4 contacts seat Shielded BUS coaxial	CX 04 BM	
2 cable clamp included in the package			

	Female inserts, 1 contact seat Shielded BUS coaxial	CX 01 BF	 46 ø 15,5
	Female inserts, 4 contacts seat Shielded BUS coaxial	CX 04 BF	
2 cable clamp included in the package			

10 A crimp contacts	section (mm ²) section (AWG)		Male	Female	 ø 3,2 25 ø 1,6 21,6 ø 3,5 ø A B B ø A
		0,14-0,37	26-22	silver	
	0,5	20		CDMA 0.5 CDFA 0.5	
	0,75	18		CDMA 0.7 CDFA 0.7	
	1	18		CDMA 1.0 CDFA 1.0	
	1,5	16		CDMA 1.5 CDFA 1.5	
	2,5	14		CDMA 2.5 CDFA 2.5	
	0,14-0,37	26-22	gold	CDMD 0.3 CDFD 0.3	
	0,5	20		CDMD 0.5 CDFD 0.5	
	0,75	18		CDMD 0.7 CDFD 0.7	
	1	18		CDMD 1.0 CDFD 1.0	
	1,5	16		CDMD 1.5 CDFD 1.5	
	2,5	14		CDMD 2.5 CDFD 2.5	

Wiring information, CD contacts

conductor section (mm ²)	conductor slot ø A (mm)	stripping length B (mm)
0,14-0,37	0,9	8
0,5	1,1	8
0,75	1,3	8
1,0	1,45	8
1,5	1,8	8
2,5	2,2	6

Wire diameter: up to 3,8 mm.

For basic or high thickness gold plating, please refer to page [E.16](#).

It is recommended to use the crimping tools and removal tools homologated by ILME (please see page [E.23](#)).

Materials

Insert	polycarbonate (PC), zinc-alloy shield
UL 94 flame rating	V-0
Colour (contacts holder)	pebble grey, RAL 7032
Contacts	copper alloy, silver ● and gold ● plated

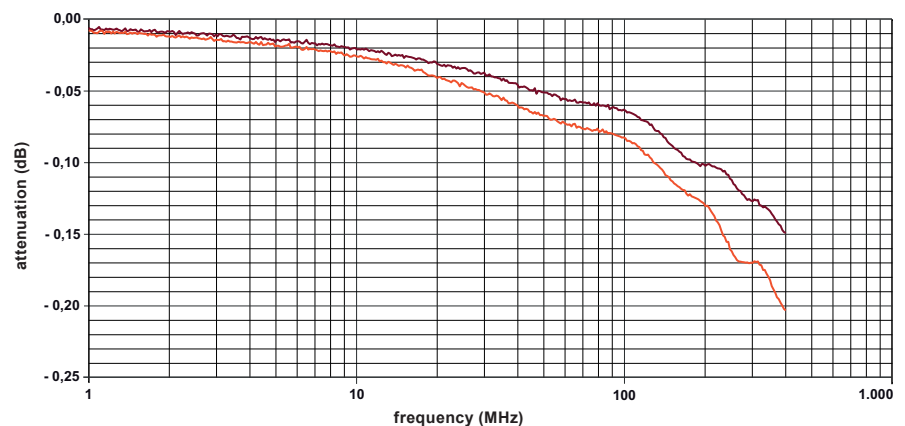
Coaxial connector **CX 01 B** cables with a typical impedance of 75 Ω (attenuation see below).

CX 04 B multiaxial connector for STP cables with 2 pairs and terminations compliant with EN 50173-1 Cat. 5 (100 MHz), compatible with 4-wire field bus protocols.

Test performed in accordance with IEC/EN 60512-25-2 (2002), 4.1.3.2 (coaxial cable only) and 4.2.2.2 (coaxial cable and connector).

Attenuation (insertion loss) 75 Ω coaxial connector (CX 01 BF)

- RG 11 A/U cable and CX 01 B connector (75 Ω)
- RG 11 A/U cable (75 Ω)



CX 08 B

5 A – 50 V


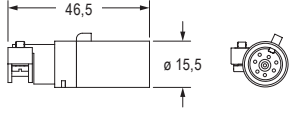

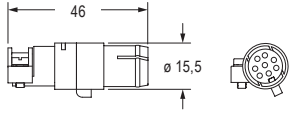





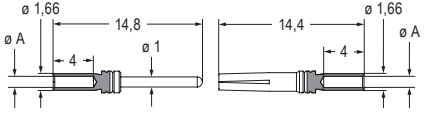


8 poles + shield

Crimp connection

EN 61984 rating	5 A 50 V 0,8 kV 3
Rated voltage (UL / CSA)	50 V
Insulation resistance	≥ 10 GΩ
Contact resistance	≤ 4 mΩ
Ambient temperature limit	-40 °C ... +85 °C
Mechanical life (cycles)	≥ 500



CAUS ECBT2.E115072 | ECBT8.E115072

Item	Description	Part No.	Dimension																					
	Male inserts, 8 contacts seat Shielded BUS multi-coaxial 2 cable clamp included in the package	CX 08 BM																						
	Female inserts, 8 contacts seat Shielded BUS multi-coaxial 2 cable clamp included in the package	CX 08 BF																						
	5 A crimp contacts section (mm ²) section (AWG) 0,08-0,21 28-24 0,13-0,33 26-22 0,33-0,52 22-20	<table border="0"> <tr> <td></td> <td>Male</td> <td>Female</td> </tr> <tr> <td></td> <td>CIMA 0.2</td> <td>CIFA 0.2</td> </tr> <tr> <td></td> <td>CIMA 0.3</td> <td>CIFA 0.3</td> </tr> <tr> <td></td> <td>CIMA 0.5</td> <td>CIFA 0.5</td> </tr> <tr> <td></td> <td>CIMD 0.2</td> <td>CIFD 0.2</td> </tr> <tr> <td></td> <td>CIMD 0.3</td> <td>CIFD 0.3</td> </tr> <tr> <td></td> <td>CIMD 0.5</td> <td>CIFD 0.5</td> </tr> </table>		Male	Female		CIMA 0.2	CIFA 0.2		CIMA 0.3	CIFA 0.3		CIMA 0.5	CIFA 0.5		CIMD 0.2	CIFD 0.2		CIMD 0.3	CIFD 0.3		CIMD 0.5	CIFD 0.5	
	Male	Female																						
	CIMA 0.2	CIFA 0.2																						
	CIMA 0.3	CIFA 0.3																						
	CIMA 0.5	CIFA 0.5																						
	CIMD 0.2	CIFD 0.2																						
	CIMD 0.3	CIFD 0.3																						
	CIMD 0.5	CIFD 0.5																						

Wiring information, CI contacts

conductor section (mm ²)	conductor slot ø A (mm)	stripping length (mm)
0,08-0,21	0,64	4
0,13-0,33	0,9	4
0,33-0,52	1,12	4

Wire diameter: up to 1,7 mm.

For basic or high thickness gold plating, please refer to page F.17.

It is recommended to use the crimping tools and removal tools homologated by ILME (please see page F.23)

Materials

Insert	polycarbonate (PC), zinc-alloy shield
UL 94 flame rating	V-0
Colour (contacts holder)	pebble grey, RAL 7032
Contacts	copper alloy, silver ● and gold ● plated

Female and male shielded connectors fit both in female and in male holder/adaptor insert.



CX 02 B
MIXO insert
Page C.62



CX 1/2 BD
21.21 insert
Page A.37

MIXO Data modules – RJ45 and HDMI



CX 01 J8UM Universal adapter

International Standard IEC 60603-7 covering RJ45 interface standardizes only the mating face and latch, and the connector performance, leaving the shell dimensions free. CX 01 J8UM is suitable to lock in place RJ45 plugs of patch cords with maximum overall dimensions 13,5 mm × 9,5 mm on the shell, 42,3 mm max length, avoiding the need to wire or crimp RJ45 plugs thus reducing installation time and costs.





Tutorial

CX 01 J8AIF / J8BIF / J8PIF overview

8-way shielded jack (female connector) in a MIXO single module format, with IDC terminations. It is a 4-pair data connector Cat. 6_A Class E_A, for transmission rates up to 10 Gbit/s (IEEE 802.3an), for solderless field wiring.

It widens the portfolio of ILME RJ45 modular connectors as an alternative to using the female/female RJ45 coupler module CX 01 J8F coupled to a plug of an RJ45 patch cord.



Can be coupled to the existing MIXO plug module CX 01 J8IM or to the CX 8 J6IM RJ45 modular connector with IDC terminations, or to the CX 01 J8M module with CX 8 J6M crimp connector (or to suitable patch cords with RJ45 plug).

Available for three different pin assignments:

- > **CX 01 J8AIF** for TIA 568A wiring
- > **CX 01 J8BIF** for TIA 568B wiring
- > **CX 01 J8PIF** for PROFINET wiring

MIXO HDMI CX 01 MI module overview

Designed for high quality video signal transmission, with HDMI Type A connectors (19-pole + shield). Supports 1.4 and 2.0 standards (HDMI = High Definition Multimedia Interface), full Ultra HD 4k@60 Hz, 4096x2160p resolution, Ethernet up to and including 18Gb/s and ARC (Audio Return Channel).

Female HDMI module CX 01 MIF hosts a female/female PCB assembly with female HDMI Type A connector on both sides, to act as a coupler between two male terminated patch cords (one on the rear of this female module, one hosted in the male module adapter on the counterpart connector).

Male HDMI module CX 01 MIM is an adapter able to host a patch cord terminated with HDMI Type A plugs of compact size, providing a latch to anchor the cable.



FOCUS

Insert features



- ▶ Locking of the HDMI male plugs through a dedicated module

RJ45 MIXO selection guide

MIXO Modules

MIXO a-f frame for housings

Housings

RJ45 female connectors Cat. 6A

RJ45 female/female coupler



CX 01 J8F
(8 data contacts)

RJ45 female/IDC jack



CX 01 J8AIF
(8 data contacts, TIA 568A coding) or
CX 01 J8BIF
(8 data contacts, TIA 568B coding) or
CX 01 J8PIF
(8 data contacts, PROFINET coding)

RJ45 female connectors Cat. 5-5e

**1 × RJ45 female crimp plug
+ 4 × 10 A CD series crimp contacts**



CX 01 JF + CX 8 JF
(8 data contacts) or
CX 01 JF + CX 8/2 JF
(8 data contacts + 2 power contacts)

**2 × RJ45 female crimp plug
+ 8 × 10 A CD series crimp contacts**



CX 02 JF* + 2 × CX 8 JF
2 × (8 data contacts) or
CX 02 JF* + 2 × CX 8/2 JF
2 × (8 data contacts + 2 power contacts)

MIXO ONE

MIXO TWO

CX 01 T**

CZ IL-BRID

CZ7 - MZ7

CX 02 TF **CX 03 TF**

CX 04 TF **CX 06 TF**

C-TYPE

IL-BRID

JEI®-P

V-TYPE

IP68

W-TYPE

E-Xtreme®

CX 02 PDF **CX 03 PDF**

CX 04 PDF **CX 06 PDF**

EMC

T-TYPE

Central lever

BIG

COB

LS-TYPE

Legend

- * cannot be used with CX 02 TM/TF MIXO frames and CX 02 PDM/PDF thermoplastic docking frames
- ** cannot be used with 49.16 surface mounting housings

Hoods

MIXO a-f frame for housings

MIXO Modules

MIXO ONE




MIXO TWO



CZ IL-BRID

CZ7 - MZ7



CX 01 T

C-TYPE

IL-BRID

JEI®-P

V-TYPE

IP68

W-TYPE

E-Xtreme®

EMC

T-TYPE

Central lever

BIG

COB

LS-TYPE


CX 02 TM **CX 03 TM**

CX 04 TM **CX 06 TM**

CX 02 PDM **CX 03 PDM**


CX 04 PDM **CX 06 PDM**

RJ45 male crimp plug




CX 01 J8M + CX 8 J6M
(8 data contacts)

RJ45 male IDC plug



CX 01 J8IM + CX 8 J6IM
(T568A, T568B, PROFINET data contacts)


ILME RJ45 patch cord adapter



CX 01 J8M + CW...J2M87
(patch cord selection, see page C.63)


CX 01 J8UM
RJ45 universal patch cord adapter

1 × RJ45 male crimp plug + 4 × 10 A CD series crimp contacts



CX 01 JM + CX 4 JM
(4 data contacts) or
CX 01 JM + CX 8 JM
(8 data contacts) or
CX 01 JM + CX 4/2 JM
(4 data + 2 power contacts) or
CX 01 JM + CX 6/2 JM
(6 data + 2 power contacts) or
CX 01 JM + CX 4E JM
(4 data contacts Cat. 5e PROFINET) or
CX 01 JM + CW...J2M 4/2, 8, 4E
(patch cord selection, see page C.66)

2 × RJ45 male crimp plug + 8 × 10 A CD series crimp contacts



CX 02 JM* + 2 × CX 4 JM
2 × (4 data contacts) or
CX 02 JM* + 2 × CX 8 JM
2 × (8 data contacts) or
CX 02 JM* + 2 × CX 4/2 JM
2 × (4 data + 2 power contacts) or
CX 02 JM* + 2 × CX 6/2 JM
2 × (6 data + 2 power contacts) or
CX 02 JM* + 2 × CX 4E JM
2 × (4 data contacts Cat. 5e PROFINET) or
CX 02 JM* + 2 × CW...J2M 4/2, 8, 4E
2 × (patch cord selection, see page C.66)

RJ45 male connectors Cat. 6a

RJ45 MIXO selection guide

C

RJ45 male connectors Cat. 5-5e

CX 01 J8

1 A 50 V

size **1 module**


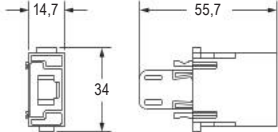

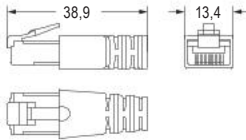

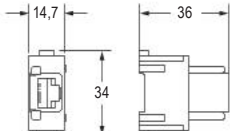
1 seat for RJ45 connectors

DATA

EN 61984 rating	1 A 50 V 0,8 kV 3
Rated voltage (UL / CSA)	50 V
Insulation resistance	≥ 10 GΩ
Contact resistance	≤ 3 mΩ
Ambient temperature limit	-40 °C ... +85 °C
Mechanical life (cycles)	≥ 500



RAUS ECBT2.E115072 | ECBT8.E115072

Item	Description	Part No.	Dimension
	Male inserts for 1 RJ45 male crimp connector Without RJ45 connector (to be ordered separately) Can be used with connecting cables CW series (RJ45 and M12x1)	CX 01 J8M	
	RJ45 male crimp connector 8 data contacts	CX 8 J6M	
	Female insert with RJ45 female-female coupler	CX 01 J8F	

Materials

Insert	polycarbonate (PC)
UL 94 flame rating	V-0
Colour	pebble grey, RAL 7032

CX 01 J8F RJ45 female connectors, Cat. 6 Class E_A technical data:

- current carrying capacity at 50 °C: 1 A;
- PoE according to IEEE 802.3af: adequate for Power over Ethernet;
- generic cabling systems: ANSI/TIA/EIA-568-C.2; ISO/IEC 11801; EN50173-1; ISO/IEC 24702 and EN 61918;
- connectors: IEC 60603-7-5;
- 10 Gigabit Ethernet according to IEEE 802.3an: adequate for 10 Gigabit Ethernet;
- custom-designed cabling systems: PROFINET Installation Guideline;
- class E_A (channel): ISO/IEC 11801; EN 50173-1.

CX 8 J6M RJ45 male crimp connectors, Cat. 6_A technical data:

- conductor diameter: solid: 0,4 - 0,51 mm (AWG 26/1 - 24/1); stranded: 0,46 - 0,61 mm (AWG 27/7 - 24/7);
- insulation diameter: 0,85 - 1,05 mm;
- cable diameter: 5 - 7 mm;
- connectors: IEC 60603-7-51;
- crimp pliers: **CJPZ T**;
- screened cable stripper: **CJST**;
- 10 Gigabit Ethernet according to IEEE 802.3an: adequate for 10 Gigabit Ethernet;
- Cat. 6_A: ISO/IEC 11801; EN 50173-1; ANSI/TIA/EIA-568-C.2
- class E_A: ISO/IEC 11801; EN 50173-1.

Accessories

Pages

MIXO Frames

Metal frames for modular units	C.94-96
Thermoplastic docking frames	C.98-101

Enclosures

Insulating MIXO holder	C.103
MIXO ONE	C.106-107
MIXO TWO	C.110-111



Tutorial



CX 01 J8I

1 A 50 V

size **1 module**

1 seats for RJ45 IDC connectors

IDC connection

EN 61984 rating	1 A 50 V 0,8 kV 3
Rated voltage (UL / CSA)	50 V
Insulation resistance	≥ 10 GΩ
Contact resistance	≤ 3 mΩ
Ambient temperature limit	-40 °C ... +85 °C
Mechanical life (cycles)	≥ 500

(pending: DNV and BV)



ECBT2.E115072 | ECBT8.E115072

Item	Description	Part No.	Dimension
	Male inserts for 1 RJ45 male IDC connector, 8 data contacts Without RJ45 connector (to be ordered separately)	CX 01 J8IM	
	RJ45 male IDC connector 8 data contacts	CX 8 J6IM	
	Female insert with 1 RJ45 IDC connector TIA 568A contact coding TIA 568B contact coding PROFINET contact coding	CX 01 J8AIF CX 01 J8BIF CX 01 J8PIF	

Materials

Insert	polycarbonate (PC)
UL 94 flame rating	V-0
Colour	pebble grey, RAL 7032

PIN assignment

Pin n°	CX 01 J8AIF T568A according to TIA/EIA 568-C.2	CX 01 J8BIF T568B according to TIA/EIA 568-C.2	CX 01 J8PIF Profinet Industrial
1	WH/GN	WH/OG	YE
2	GN	OG	OG
3	WH/OG	WH/GN	WH
4	BU	BU	—
5	WH/BU	WH/BU	—
6	OG	GN	BU
7	WH/BN	WH/BN	—
8	BN	BN	—

CX 01 J8I..F RJ45 female IDC connectors, Cat. 6 Class E_A technical data:

- current carrying capacity at 50 °C: 1 A;
- PoE according to IEEE 802.3at: adequate for Power over Ethernet+ (PoE+);
- conductor diameter: solid: 0,40 - 0,64 mm (AWG 26/1 - 22/1); stranded: 0,48 - 0,76 mm (AWG 26/7 - 22/7);
- generic cabling systems: ANSI/TIA/EIA-568-C.2; ISO/IEC 11801; EN50173-1; ISO/IEC 24702 and EN 61918;
- insulation diameter: 0,85 - 1,6 mm;
- cable diameter: 5,5 - 9 mm;
- connectors: IEC 60603-7-51;
- 10 Gigabit Ethernet according to IEEE 802.3an: adequate for 10 Gigabit Ethernet;
- custom-designed cabling systems: PROFINET Installation Guideline;
- Cat. 6: ANSI/TIA/EIA-568-C.2;
- Cat. 6A: ISO/IEC 11801; DIN EN 50173-1;
- class E_A (channel): ISO/IEC 11801; EN 50173-1.

CX 8 J6IM RJ45 male IDC connectors, Cat. 6 Class E_A technical data:

- conductor diameter: solid: 0,41 - 0,64 mm (AWG 26/1 - 22/1); stranded: 0,48 - 0,76 mm (AWG 26/7 - 22/7);
- insulation diameter: 0,85 - 1,6 mm;
- cable diameter: 5,5 - 8,5 mm;
- connectors: IEC 60603-7-5;
- wrenches pliers: **CJPW K**;
- 10 Gigabit Ethernet according to IEEE 802.3an: adequate for 10 Gigabit Ethernet;
- custom-designed cabling systems: PROFINET Installation Guideline;
- Cat. 6: ANSI/TIA/EIA-568-C.2;
- Cat. 6A: ISO/IEC 11801; DIN EN 50173-1;
- class E_A: ISO/IEC 11801; EN 50173-1;
- custom-designed cabling systems: PROFINET Installation Guideline;
- class E_A (channel): ISO/IEC 11801; EN 50173-1.

Accessories

Pages

MIXO Frames

Metal frames for modular units	C.94-96
Thermoplastic docking frames	C.98-101

Enclosures

Insulating MIXO holder	C.103
MIXO ONE	C.106-107
MIXO TWO	C.110-111

To be used with high construction enclosures (T-TYPE hood, M32/M40 only and CZAV/MZAV top entry only), bulkhead mounting housing or COB..BC/TCQ/TSF/TSFS only.



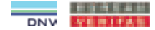
Tutorial

CX 01 J8U


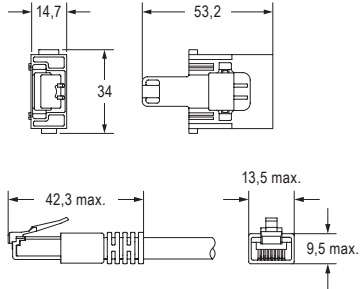
1 A 50 V

size **1 module**
1 seat for RJ45 connectors

EN 61984 rating	1 A 50 V 0,8 kV 3
Rated voltage (UL / CSA)	50 V
Insulation resistance	≥ 10 GΩ
Contact resistance	≤ 3 mΩ
Ambient temperature limit	-40 °C ... +125 °C
Mechanical life (cycles)	≥ 500



CALUS ECBT2.E115072 | ECBT8.E115072

Item	Description	Part No.	Dimension
	RJ45 universal patch cord adapter	CX 01 J8UM	



Watch our clip

Materials

Insert	polycarbonate (PC)
UL 94 flame rating	V-0
Colour	pebble grey, RAL 7032

Accessories

MIXO Frames

	Pages
Metal frames for modular units	C.94-95
Thermoplastic docking frames	C.98-101


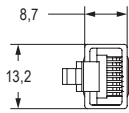
Enclosures

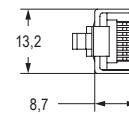
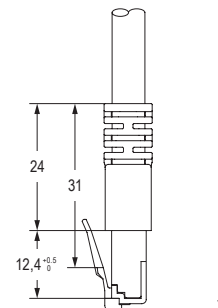
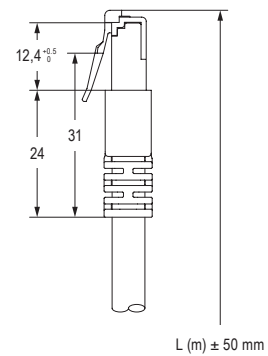
Insulating MIXO holder	C.103
MIXO ONE	C.106-107
MIXO TWO	C.110-111

CW

RJ45 patch cord

Ambient temperature limit -40 °C ... +75 °C

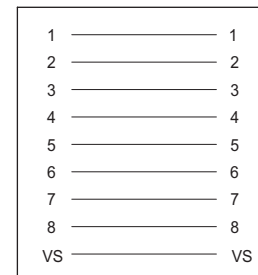
Item	Description	Part No.	L(m)	Dimension
	2×RJ45 male connector with 8 data contacts, S/FTP Cat. 6 _A cable 4×2 AWG 27/7 - Shielded Material PUR Can be used with MIXO RJ45 CX 01 J8M and CX 01 J8UM male connectors	CW 1 J2M87	1	
		CW 2 J2M87	2	
		CW 3 J2M87	3	
		CW 5 J2M87	5	
		CW 7.5J2M87	7,5	
		CW 10 J2M87	10	
		CW 15 J2M87	15	



Materials

Cable jacket	hard polyurethane foam (PUR)
Colour	green, RAL 6018

CW wiring diagram



CX 01 J

10 A 250 V

 size **2 modules**

4 poles + 1 seat for RJ45 connectors Cat. 5 Ethernet

Crimp connection

EN 61984 rating	10 A 250 V 4 kV 3
Rated voltage (RJ45 connector)	35 V _{AC} / 50 V _{DC}
Rated current (RJ45 connector)	2,1 A at 70 °C
Insulation resistance	≥ 10 GΩ
Contact resistance	≤ 3 mΩ
Ambient temperature limit	-40 °C ... +120 °C
Mechanical life (cycles)	≥ 500



CAIUS® ECBT2.E115072 | ECBT8.E115072

Item	Description	Part No.	Dimension
	Male inserts for 1 RJ45 male connector and for 4 CDM 10 A contacts Without RJ45 connector and contacts (to be ordered separately)	CX 01 JM	
	RJ45 plug, 4 data contacts RJ45 plug, 4 data contacts, Cat. 5e Profinet® RJ45 plug, 4 data + 2 power contacts RJ45 plug, 6 data + 2 power contacts RJ45 plug, 8 data contacts	CX 4 JM CX 4E JM CX 4/2 JM CX 6/2 JM CX 8 JM	
	Female inserts for 1 RJ45 female connector and for 4 CDF 10 A contacts Without RJ45 connector and contacts (to be ordered separately) To be used with high or flush mounting enclosures	CX 01 JF	
	RJ45 coupler jack, 4 data contacts* RJ45 coupler jack, 4 data + 2 power contacts* RJ45 coupler jack, 8 data contacts RJ45 coupler jack, 8 data + 2 power contacts	CX 4 JF CX 4/2 JF CX 8 JF CX 8/2 JF	

* on request

10 A crimp contacts

section (mm ²)	section (AWG)
0,14-0,37	26-22
0,5	20
0,75	18
1	18
1,5	16
2,5	14
0,14-0,37	26-22
0,5	20
0,75	18
1	18
1,5	16
2,5	14

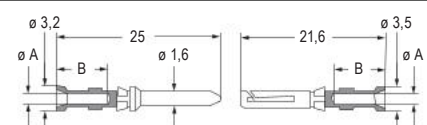
Wire diameter: up to 3,8 mm.

 For basic or high thickness gold plating, please refer to page [F.16](#)

 It is recommended to use the crimping tools and removal tools homologated by ILME (please see page [F.23](#))

Male Female

silver	CDMA 0.3	CDFA 0.3
	CDMA 0.5	CDFA 0.5
	CDMA 0.7	CDFA 0.7
	CDMA 1.0	CDFA 1.0
	CDMA 1.5	CDFA 1.5
	CDMA 2.5	CDFA 2.5
gold	CDMD 0.3	CDFD 0.3
	CDMD 0.5	CDFD 0.5
	CDMD 0.7	CDFD 0.7
	CDMD 1.0	CDFD 1.0
	CDMD 1.5	CDFD 1.5
	CDMD 2.5	CDFD 2.5



Wiring information, CD contacts

conductor section (mm ²)	conductor slot ø A (mm)	stripping length B (mm)
0,14-0,37	0,9	8
0,5	1,1	8
0,75	1,3	8
1,0	1,45	8
1,5	1,8	8
2,5	2,2	6

 - ø_{max} insulating conductors: 1 mm (data) and 1,4 mm (power and **CX 4E JM**)

 - ø_{max} complete cable: 7 mm (6,9 mm for **CX 8 JM**)

Materials

Insert	polycarbonate (PC)
Screening	nickel-plated brass
UL 94 flame rating	V-0
Colour	pebble grey, RAL 7032
Contacts	copper alloy, silver ● and gold ● plated

RJ45 insert, Class 5 Ethernet features, IDC terminals:

- for 0,22 mm² (AWG 24, 7-strands wire) data contacts **CX 4 JM**;
- for 0,14 mm² (AWG 26, 7-strands wire) or 0,22 mm² (AWG 24/7) data contacts **CX 4/2 JM**;
- for 0,34 mm² (AWG 22, 7-strands wire) or 0,38 mm² (AWG 22/19) power contacts;
- for 0,14 mm² (AWG 26, 7-strands wire) data contacts **CX 6/2 JM**;
- for 0,25 mm² (AWG 23, 19-strands wire) power contacts;
- for 0,14 mm² (AWG 26, 7-strands wire) data contacts **CX 8 JM**;
- for 0,34 mm² (AWG 22, 7-strands wire) data contacts **CX 4E JM**.

Accessories

Pages

MIXO Frames

Metal frames for modular units	C.95
Thermoplastic docking frames	C.98-101

CX 02 J

10 A 250 V

size **3 modules**

8 poles + 2 seats for RJ45 connectors Cat. 5 Ethernet

Crimp connection

EN 61984 rating	10 A 250 V 4 kV 3
Rated voltage (RJ45 connector)	35 V _{AC} / 50 V _{DC}
Rated current (RJ45 connector)	2,1 A at 70 °C
Insulation resistance	≥ 10 GΩ
Contact resistance	≤ 3 mΩ
Ambient temperature limit	-40 °C ... +120 °C
Mechanical life (cycles)	≥ 500



ALUS ECBT2.E115072 | ECBT8.E115072

Item	Description	Part No.	Dimension
	Male inserts for 2 RJ45 male connectors and for 8 CDM 10 A contacts Without RJ45 connector and contacts (to be ordered separately)	CX 02 JM	
	RJ45 plug, 4 data contacts RJ45 plug, 4 data contacts, Cat. 5e Profinet® RJ45 plug, 4 data + 2 power contacts RJ45 plug, 6 data + 2 power contacts RJ45 plug, 8 data contacts	CX 4 JM CX 4E JM CX 4/2 JM CX 6/2 JM CX 8 JM	
	Female inserts for 2 RJ45 female connectors and for 8 CDF 10 A contacts Without RJ45 connector and contacts (to be ordered separately) To be used with high or flush mounting enclosures	CX 02 JF	
	RJ45 coupler jack, 4 data contacts* RJ45 coupler jack, 4 data + 2 power contacts* RJ45 coupler jack, 8 data contacts RJ45 coupler jack, 8 data + 2 power contacts	CX 4 JF CX 4/2 JF CX 8 JF CX 8/2 JF	

* on request

10 A crimp contacts		Male	Female	
section (mm ²)	section (AWG)			
0,14-0,37	26-22	CDMA 0.3	CDFA 0.3	
0,5	20	CDMA 0.5	CDFA 0.5	
0,75	18	CDMA 0.7	CDFA 0.7	
1	18	CDMA 1.0	CDFA 1.0	
1,5	16	CDMA 1.5	CDFA 1.5	
2,5	14	CDMA 2.5	CDFA 2.5	
0,14-0,37	26-22	CDMD 0.3	CDFD 0.3	
0,5	20	CDMD 0.5	CDFD 0.5	
0,75	18	CDMD 0.7	CDFD 0.7	
1	18	CDMD 1.0	CDFD 1.0	
1,5	16	CDMD 1.5	CDFD 1.5	
2,5	14	CDMD 2.5	CDFD 2.5	

Wire diameter: up to 3,8 mm.

For basic or high thickness gold plating, please refer to page [F.16](#)

It is recommended to use the crimping tools and removal tools homologated by ILME (please see page [F.23](#))

Wiring information, CD contacts

conductor section (mm ²)	conductor slot ø A (mm)	stripping length B (mm)
0,14-0,37	0,9	8
0,5	1,1	8
0,75	1,3	8
1,0	1,45	8
1,5	1,8	8
2,5	2,2	6

- ø_{max} insulating conductors: 1 mm (data) and 1,4 mm (power and **CX 4E JM**)

- ø_{max} complete cable: 7 mm (6,9 mm for **CX 8 JM**)

Materials

Insert	polycarbonate (PC)
Screening	nickel-plated brass
UL 94 flame rating	V-0
Colour	pebble grey, RAL 7032
Contacts	copper alloy, silver ● and gold ● plated

Accessories

Pages

MIXO Frames	
Metal frames for modular units	C.95
Thermoplastic docking frames	C.98-101


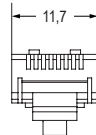

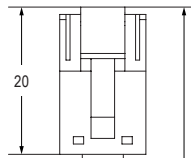
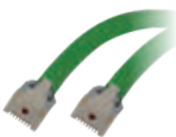
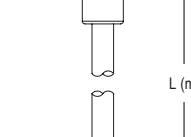

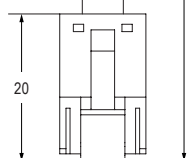

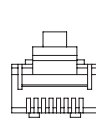
RJ45 insert, Class 5 Ethernet features, IDC terminals:

- for 0,22 mm² (AWG 24, 7-strands wire) data contacts **CX 4 JM**;
- for 0,14 mm² (AWG 26, 7-strands wire) or 0,22 mm² (AWG 24/7) data contacts **CX 4/2 JM**;
- for 0,34 mm² (AWG 22, 7-strands wire) or 0,38 mm² (AWG 22/19) power contacts;
- for 0,14 mm² (AWG 26, 7-strands wire) data contacts **CX 6/2 JM**;
- for 0,25 mm² (AWG 23, 19-strands wire) power contacts;
- for 0,14 mm² (AWG 26, 7-strands wire) data contacts **CX 8 JM**;
- for 0,34 mm² (AWG 22, 7-strands wire) data contacts **CX 4E JM**.

CW

RJ45 patch cord Cat. 5 Ethernet

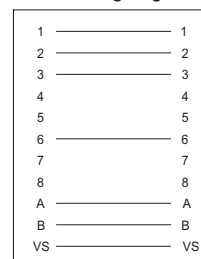
Rated voltage	35 V _{Ac} / 50 V _{Dc}
Rated current	2,1 A at 70 °C
Ambient temperature limit	-40 °C ... +120 °C

Item	Description	Part No.	L(m)	Dimension
	1×RJ45 male connector With 4 data + 2 power contacts Can be used with CX 01 JM and CX 02 JM modular units	CW 0.5 JM4/2 CW 2 JM4/2 CW 5 JM4/2 CW 10 JM4/2	0,5 2 5 10	
	1×RJ45 male connector With 8 data contacts Can be used with CX 01 JM and CX 02 JM modular units	CW 0.5 JM8 CW 2 JM8 CW 5 JM8 CW 10 JM8	0,5 2 5 10	
	2×RJ45 male connector With 8 data contacts Can be used with CX 01 JM and CX 02 JM modular units	CW 0.5 J2M8 CW 2 J2M8 CW 5 J2M8 CW 10 J2M8	0,5 2 5 10	
	1×RJ45 male connector With 4 data contacts, Cat. 5e Can be used with CX 01 JM and CX 02 JM modular units	CW 0.5 JM4E CW 2 JM4E CW 5 JM4E CW 10 JM4E	0,5 2 5 10	
	2×RJ45 male connector With 4 data contacts, Cat. 5e Can be used with CX 01 JM and CX 02 JM modular units	CW 0.5 J2M4E CW 2 J2M4E CW 5 J2M4E CW 10 J2M4E	0,5 2 5 10	

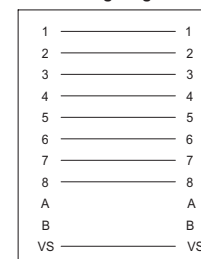
Materials

Cable jacket	polyvinyl chloride (PVC)
Colour	green, RAL 6018

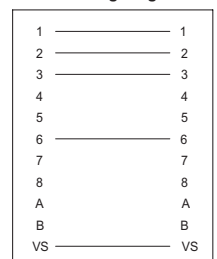
J2M4/2 wiring diagram



J2M8 wiring diagram



J2M4E wiring diagram



CX 01 U


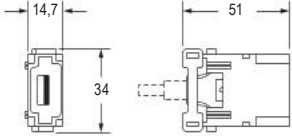

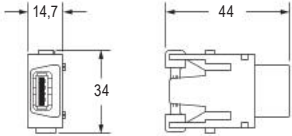

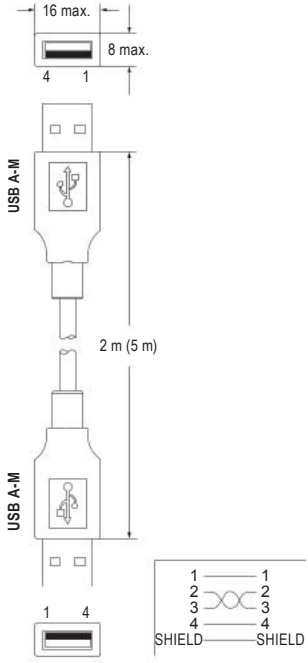
1 A 50 V

size **1 module**
USB connectors

EN 61984 rating	1 A 50 V 0,8 kV 3
Insulation resistance	≥ 10 GΩ
Contact resistance	≤ 3 mΩ
Ambient temperature limit	-25 °C ... +80 °C



CAUS ECBT2.E115072 | ECBT8.E115072

Item	Description	Part No.	Dimension
	Male insert without USB male connector (patch-cord to be ordered separately)	CX 01 UM	
	Female insert with USB 2.0 female-female coupler	CX 01 UF	
	Patch-cord USB-A/USB-A, 2 m Patch-cord USB-A/USB-A, 5 m	CW 2 UAM CW 5 UAM	

Materials

Insert	polycarbonate (PC)
UL 94 flame rating	V-0
Colour	pebble grey, RAL 7032

Accessories

Accessories	Pages
MIXO Frames	
Metal frames for modular units	C.94-98
Thermoplastic docking frames	C.98-101
Enclosures	
Insulating MIXO holder	C.103
MIXO ONE	C.106-107
MIXO TWO	C.110-111

Can be used in bulkhead mounting housings or in high construction housings or in high construction hoods.

CX 01 MI

0,5 A 40 V


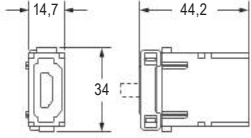

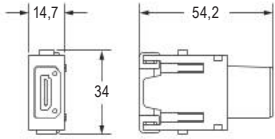

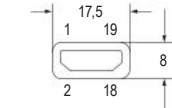

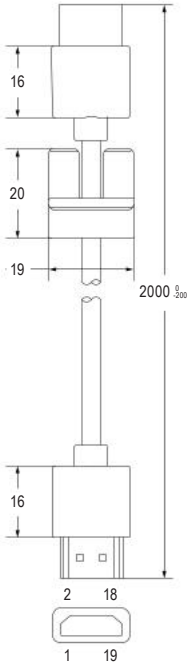
size 1 module

HDMI Type A connectors

EN 61984 rating	0,5 A 40 V 0,8 kV 3
Ambient temperature limit	-40 °C ... +70 °C



CRUS ECBT2.E115072 | ECBT8.E115072

Item	Description	Part No.	Dimension
	Module for male connector (patch-cord to be ordered separately)	CX 01 MIM	
	HDMI Type A modular unit, female/female connector (patch-cord to be ordered separately)	CX 01 MIF	
	HDMI Type A patch cord with cable clamp for male module, 2 m With the male module, CX 01 MIM , it is mandatory to use the CW 2 MIAM patch cord, supplied with a specific cable clamp, tailored to fit the outline of the HDMI connector.	CW 2 MIAM	
	HDMI Type A patch cord for female module, 2 m With the female module, CX 01 MIF , it is mandatory to use the CW 2 MIAF patch cord, twin of the CW 2 MIAM but without the cable clamp	CW 2 MIAF	

Materials

Insert	polycarbonate (PC)
UL 94 flame rating	V-0
Colour	pebble grey, RAL 7032

Accessories

Pages

MIXO Frames

Metal frames for modular units	C.94-95
Thermoplastic docking frames	C.98-101

Enclosures

Insulating MIXO holder	C.103
MIXO ONE	C.106-107
MIXO TWO	C.110-111

Due to the reduced electrical engagement length of the HDMI standard, it is needed to install these modules in enclosures combinations that allow to couple the two MIXO frames within 20,5 mm between the fixing points. Therefore we recommend to install them using V-TYPE, T-TYPE with PE jumpers, MIXO ONE and COB enclosures.

- for high quality video signal transmission, with HDMI Type A connectors (19-pole + shield);
- supports HDMI 1.4 and 2.0 standards, full Ultra HD 4k@60 Hz, 4096p × 2160p resolution;
- supports Ethernet up to and including 18 Gb/s;
- supports ARC (Audio Return Channel).

It is recommended the use of **CRF CX / CRM CX** coding pins together with relevant MIXO frames.


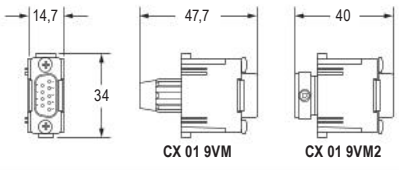

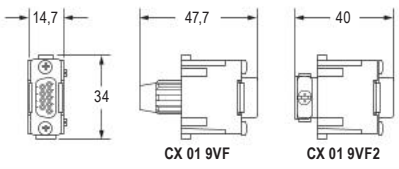

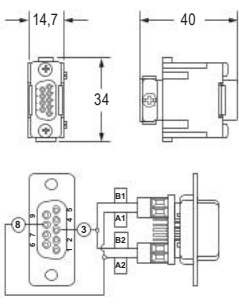


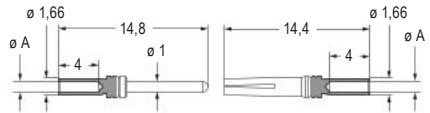
CX 01 9V/CX 01 9V2

5 A 50 V


size **1 module**
9 poles D-SUB connector

Crimp and Screw connection

EN 61984 rating	5 A	50 V	0,8 kV	3
Rated voltage (UL / CSA)				50 V
Insulation resistance				≥ 10 GΩ
Contact resistance				≤ 4 mΩ
Ambient temperature limit	CX 01 9V	-40 °C ...	+70 °C	
	CX 01 9V2	-40 °C ...	+85 °C	
Mechanical life (cycles)				≥ 500

Item	Description	Part No.	Dimension															
	Male inserts, single cable entry Male inserts, double cable entry For 1 D-SUB connector with included shield CX 01 9VM2 only for contacts 0,2..0,5 mm ²	CX 01 9VM CX 01 9VM2																
	Female inserts, single cable entry Female inserts, double cable entry For 1 D-SUB connector with included shield CX 01 9VF2 only for contacts 0,2..0,5 mm ²	CX 01 9VF CX 01 9VF2																
	Female inserts, double cable entry For 1 D-SUB RS-485 connector, T-connection - To be coupled with CX 01 9VM - Cannot be used with CI contacts	CX 01 9VTF																
	5 A crimp contacts section (mm ²) section (AWG) 0,08-0,21 28-24 0,13-0,33 26-22 0,33-0,52 22-20 0,52-0,75 20-18	Male  CIMD 0.2 CIMD 0.3 CIMD 0.5 CIMD 0.7	Female CIFD 0.2 CIFD 0.3 CIFD 0.5 CIFD 0.7															
	Wire diameter: up to 2,1 mm. For basic or high thickness gold plating, please refer to page F.17 It is recommended to use the crimping tools and removal tools homologated by ILME (please see page F.23) It is recommended the use of CRF CX / CRM CX coding pins together with relevant MIXO frames.																	
			Wiring information, CI contacts <table border="1"> <thead> <tr> <th>conductor section (mm²)</th> <th>conductor slot ø A (mm)</th> <th>stripping length (mm)</th> </tr> </thead> <tbody> <tr> <td>0,08-0,21</td> <td>0,64</td> <td>4</td> </tr> <tr> <td>0,13-0,33</td> <td>0,9</td> <td>4</td> </tr> <tr> <td>0,33-0,52</td> <td>1,12</td> <td>4</td> </tr> <tr> <td>0,52-0,75</td> <td>1,3</td> <td>4</td> </tr> </tbody> </table>	conductor section (mm ²)	conductor slot ø A (mm)	stripping length (mm)	0,08-0,21	0,64	4	0,13-0,33	0,9	4	0,33-0,52	1,12	4	0,52-0,75	1,3	4
conductor section (mm ²)	conductor slot ø A (mm)	stripping length (mm)																
0,08-0,21	0,64	4																
0,13-0,33	0,9	4																
0,33-0,52	1,12	4																
0,52-0,75	1,3	4																

Materials

Insert	polycarbonate (PC), zinc-alloy shield
UL 94 flame rating	V-0
Colour	pebble grey, RAL 7032
Contacts	copper alloy, gold  plated

Accessories

Pages

MIXO Frames

Metal frames for modular units	C.94-95
Thermoplastic docking frames	C.98-101

Enclosures

Insulating MIXO holder	C.103
MIXO ONE	C.106-107
MIXO TWO	C.110-111

Can be used in bulkhead mounting housings or in high construction housings or in high construction hoods.



Tutorial
CX 01 9V



Tutorial
CX 01 9VTF

CX 04 R


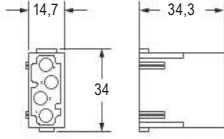

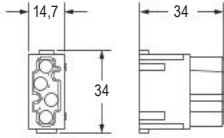

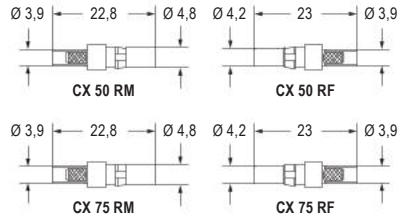
1,5 A 50 V

Crimp connection

EN 61984 rating	1,5 A 50 V 0,8 kV 3
Insulation resistance	≥ 5 GΩ
Voltage	750 V rms (test); 250 V rms (working)
Frequency	DC to 6 GHz
Return loss	≥ 21 dB, DC to 2 GHz; ≥ 19 dB, 2 to 6 GHz
Insertion loss	≥ 0,1 × √f(GHz) dB
Contact resistance	≤ 10 mΩ (center); ≤ 3 mΩ (outer)
RF-leakage	≥ 80 dB, up to 0,5 GHz; ≥ 65 dB, up to 1,5 GHz
Ambient temperature limit	-40 °C ... +125 °C
Mechanical life (cycles)	≥ 500



CAIUS ECBT2.E115072 | ECBT8.E115072

Item	Description	Part No.	Dimension
	Male inserts for male contacts Without contacts (to be ordered separately)	CX 04 RM	
	Female inserts for male contacts Without contacts (to be ordered separately)	CX 04 RF	
	Male coaxial contacts 50 Ω Female coaxial contacts 50 Ω Male coaxial contacts 75 Ω Female coaxial contacts 75 Ω	CX 50 RM CX 50 RF CX 75 RM CX 75 RF	

CX R contacts information

coaxial contacts	for cables	external diameter	part No.
50 Ω	RG 316/U	2,49 ±0,1	CX 50 R
50 Ω	RG 174/U	2,79 ±0,127	
50 Ω	RG 188 A/U	2,79 max.	CX 75 R
75 Ω	RG 179 B/U	2,54 ±0,127	
75 Ω	RG 187 A/U	2,79 max.	
75 Ω	TCZ 75 101	2,79 max.	

It is recommended to crimp the contacts CX R with crimping tools COPZ (see page [E.23](#)).

It is recommended the use of CRF CX / CRM CX coding pins together with relevant MIXO frames.

Materials

Insert	polycarbonate (PC)
UL 94 flame rating	V-0
Colour	white, RAL 7035

Accessories

Pages

MIXO Frames

Metal frames for modular units	C.94-95
Thermoplastic docking frames	C.98-101

Enclosures

Insulating MIXO holder	C.103
MIXO ONE	C.106-107
MIXO TWO	C.110-111

CX 04 L


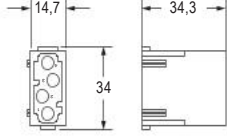

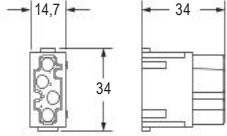

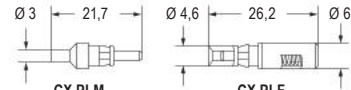

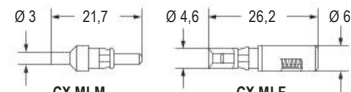
size **1 module**
4 seats for POF or MOST® contacts
 (acc. to DIN 41626-3)

Crimp connection

Insulation resistance	≥ 1 GΩ
Contact resistance	≤ 30 mΩ
Attenuation	< 2,5 dB
Ambient temperature limit	-40 °C ... +85 °C
Mechanical life (cycles)	≥ 500



CAUS ECBT2.E115072 | ECBT8.E115072

Item	Description	Part No.	Dimension
	Male inserts for male contacts Without contacts (to be ordered separately)	CX 04 LM	
	Female inserts for male contacts Without contacts (to be ordered separately)	CX 04 LF	
	Male crimp contacts POF, 1,0 mm Female crimp contacts POF, 1,0 mm Max external diameter: 2,2 mm Cable stripping length, male contact: min. 12 mm Cable stripping length, female contact: min. 15	CX PLM CX PLF	
	Male crimp contacts MOST® 1/1,5 mm Female crimp contacts MOST® 1/1,5 mm Max external diameter: 2,3 mm	CX MLM CX MLF	

Materials

Insert	polycarbonate (PC)
UL 94 flame rating	V-0
Colour	pebble grey, RAL 7032

It is recommended to use CLASS enclosures with two levers or V-TYPE enclosures (with one or two levers) that provides a higher coupling depth due to the higher locking force they produce. We further recommend the use of **CRF CX / CRM CX** coding pins together with relevant MIXO frames.

Accessories	Pages
MIXO Frames	
Metal frames for modular units	C.94-95
Thermoplastic docking frames	C.98-101
Enclosures	
Insulating MIXO holder	C.103
MIXO ONE	C.106-107
MIXO TWO	C.110-111

MIXO Data modules – Fibre Optic



SC F/O modules

CX 04 SCF /SCM

The adapter CX 04 SC enables use of fibre optic SC contacts, up to 4 SC contacts per connector, according to IEC 61754-4:2022, for indoor or outdoor heavy-duty industrial applications, with ILME connector enclosures.

The female inserts are provided with 4 ceramic (zirconia) type split alignment sleeves, for minimal insertion loos and are best suitable for single-mode fibre optic cable connectors. As optional accessory, metallic (phosphor bronze) split alignment sleeves are also available for more durable (less prone to cracking) applications, but less demanding precision alignment, thus most suitable for multi-mode fibre applications.

The fibre optic SC contacts (genderless, to be purchased separately) are available both for multi-mode fibres (50/125 µm or 62,5/125 µm) and single-mode fibre (9/125 µm).

The fibre optic SC contacts are also available for the hard-clad silica (HCS) or polymer-clad fibre (PCF) 200/230 µm fibre optic cables and for the less demanding, with shorter transmission distance covered, but more cost effective POF Ø 1 mm applications, available with crimp technique version (crimping tool required).

- > **CL 125 SC** - SC contact for GI fibre 50/125 µm or 62,5/125 µm
- > **CL POF SC** - SC contact for 1 mm Ø POF fibre





Tutorial

LC F/O modules

CX 06 LCF /LCM

Single-sized module adapter for up to 6 LC type F/O contacts according to IEC 61754-20:2012 + AMD1:2022, or patch cords terminated with such F/O contacts.

The LC contacts, being more compact, allow a higher density, i.e. a higher number of contacts: in the single-sized module dimension the quantity of F/O lines rises from 4 to 6 (compared to the SC F/O module).

As for the SC F/O contacts, also the LC ones are genderless.

The supporting accessories of the new LC modules (F/O contact holders, female and male, respectively **CX 06 LCF** and **CX 06 LCM**) include the **LC F/O contacts** (two identical contacts required for each link, available for different genre of fibre: multi-mode fibres (50/125 µm or 62,5/125 µm) and single-mode fibre (9/125 µm).

The same versions are available with two different outer insulation diameters: 2 mm and 3 mm.

- > For long transmission distances the single-mode F/O and the relevant contacts are the most suitable (although, being the fibre thinner, the required precise wiring results more difficult).
- > The multi-mode F/O, with larger core diameter, has also a lower cost and, even if transmission performance is suitable for lower distances, the wiring is relatively easier (the fibre core Ø is 7 times larger than that of the single-mode one).

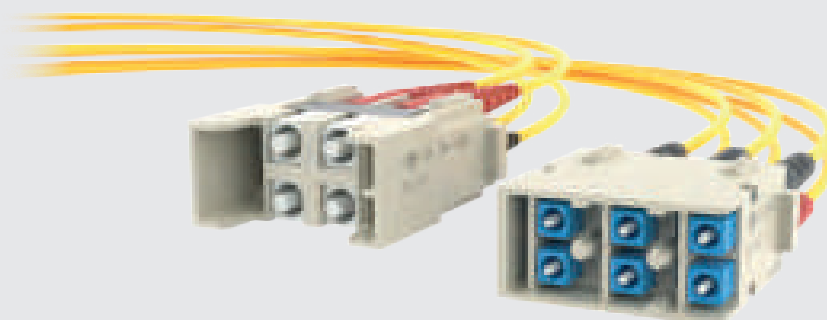
Although LC contacts are made available, the delicacy and complexity of a reliable wiring and the cost of the relevant tools and test equipment suggests, for relatively limited number of links, the use of already terminated **duplex patch cords** of suitable cable length.

	LC F/O contact		Ø	fibre core	core sheathing	overall F/O cable Ø
	CL 9/125 LC2	single-mode fibre	9/125 µm	2 mm	9 µm	125 µm
CL 9/125 LC3	3 mm			9 µm	125 µm	3 mm
CL 125 LC2	multi-mode fibres	50/125 µm	2 mm	50 µm	125 µm	2 mm
CL 125 LC3		62,5/125 µm	3 mm	62,5 µm	125 µm	3 mm

A removal tool **CLCES** is required for removing the F/O LC contacts (and the relevant attached F/O cable) from the **CX 06 LCF /LCM** adapters.

FOCUS

SC and LC modules comparison



CX 04 SC

 size **1 module**
4 seats for fibre optic SC contacts

Crimp connection

Insulating resistance	≥ 10 GΩ
Ambient temperature limit	-40 °C ... +85 °C
Cable operating temperature limit	-5 °C ... +55 °C
Cable storage temperature limit	-30 °C ... +70 °C
Cable installation temperature limit	-5 °C ... +50 °C
Cable flame retardancy according to:	IEC 60332-1
Halogen-free according to:	IEC 60754-2
Mechanical life (cycles)	≥ 500



ECBT2.E115072 | ECBT8.E115072

Item	Description	Part No.	L(m)	Dimension
	Male insert for 4 SC contacts Without contacts (to be ordered separately)	CX 04 SCM		
	Female insert with ceramic sleeve, for 4 SC contacts, with metal fixing plate	CX 04 SCF		
	Female insert with metal sleeve, for 4 SC contacts, with metal fixing plate Without contacts (to be ordered separately)	CX 04 SCF-H		
	SC contact for single-mode fibre E9/125 µm	CL 9/125 SC		
	SC contact for multi-mode fibre G50/125 µm or G62,5/125 µm	CL 125 SC		
	SC contact for 1 mm Ø POF	CL POF SC		
	SC duplex patch cord, single-mode fibre E9/125 µm, yellow cable	CW 1 SC9 CW 2 SC9 CW 3 SC9 CW 5 SC9 CW 10 SC9	1 2 3 5 10	
	SC duplex patch cord, multi-mode fibre G50/125 µm, orange cable	CW 1 SC50 CW 2 SC50 CW 3 SC50 CW 5 SC50 CW 10 SC50	1 2 3 5 10	
	SC duplex patch cord, multi-mode fibre G62,5/125 µm, orange cable	CW 1 SC62 CW 2 SC62 CW 3 SC62 CW 5 SC62 CW 10 SC62	1 2 3 5 10	

Materials

Insert	polycarbonate (PC)
Cable insulation	polyvinyl chloride (PVC)
UL 94 flame rating	V-0
Colour	pebble grey, RAL 7032

Notes:

- Adapter inserts designed to be used with SC contacts;
- SC contact for SI (Step Index) FIBRE (HCS®) 200/230 µm:
[CL 230 SC](#) (on request);
- base equipment for SC contact GI FIBRE:
[CLKZ 125 SC](#) (If this application is required, please contact ILME S.p.A.)
- supplementary set for POF: [CLKZ POF](#), to be ordered with [CLKZ 125 SC](#)
(If this application is required, please contact ILME S.p.A.)

Accessories

Accessories	Pages
MIXO Frames	
Metal frames for modular units	C.94-95
Thermoplastic docking frames	C.98-101
Enclosures	
Insulating MIXO holder	C.103
MIXO ONE	C.106-107
MIXO TWO	C.110-111

Can be used in bulkhead mounting housings or in high construction housings or in high construction hoods.

CX 06 LC


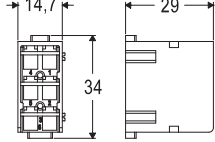

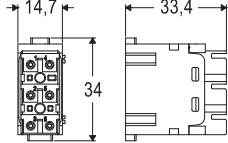

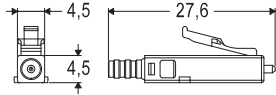


size **1 module**
6 seats for fibre optic LC contacts

Crimp connection

Insulating resistance	≥ 10 GΩ
Ambient temperature limit	-40 °C ... +85 °C
Cable operating temperature limit	-25 °C ... +70 °C
Mechanical life (cycles)	≥ 500

(pending: DNV and BV)

(pending: cURus)

Item	Description	Part No.	L(m)	Dimension
	Male insert for 6 LC contacts Without contacts (to be ordered separately)	CX 06 LCM		
	Female insert with ceramic sleeve, for 6 LC contacts Without contacts (to be ordered separately)	CX 06 LCF		
	LC contacts for single-mode fibre optic E9/125 µm (2 mm sheath)	CL 9/125 LC2		
	LC contacts for single-mode fibre optic E9/125 µm (3 mm sheath)	CL 9/125 LC3		
	LC contacts for multi-mode fibre optic G50/125 µm (2 mm sheath)	CL 125 LC2		
	LC contacts for multi-mode fibre optic G62,5/125 µm (3 mm sheath)	CL 125 LC3		
	LC duplex patch cord for single-mode fibre optic E9/125 µm	CW 1 LC9 CW 2 LC9 CW 3 LC9 CW 5 LC9 CW 10 LC9	1 2 3 5 10	
	LC duplex patch cord for multi-mode fibre optic G50/125 µm	CW 1 LC50 CW 2 LC50 CW 3 LC50 CW 5 LC50 CW 10 LC50	1 2 3 5 10	
	LC duplex patch cord for multi-mode fibre optic G62,5/125 µm	CW 1 LC62 CW 2 LC62 CW 3 LC62 CW 5 LC62 CW 10 LC62	1 2 3 5 10	

Materials

Insert	polycarbonate (PC)
Cable insulation	polyvinyl chloride (PVC)
UL 94 flame rating	V-0
Colour	pebble grey, RAL 7032

Extraction tool **CLCES** for LC contact and LC duplex patch cord see page F.59

Accessories

Pages

MIXO Frames

Metal frames for modular units	C.94-95
Thermoplastic docking frames	C.98-101

Enclosures

Insulating MIXO holder	C.103
MIXO ONE	C.106-107
MIXO TWO	C.110-111

Can be used in bulkhead mounting housings or in high construction housings or in high construction hoods.

MIXO Pneumatic modules



The MIXO modules are designed for the transmission of clean compressed air by using specific removable contacts in metal and thermoplastic versions.

The MIXO pneumatic modules allow to easily connect or disconnect a hose or tube under pressure, combining the electrical wiring and the pneumatic line with a single connector.

The **thermoplastic** and **metal** removable pneumatic contacts come in two versatile variants: for outer diameter OD (push-in attachment of tubes to the quick-fitting contacts), or inner diameter ID (push-over attachment of tubes over barbed straight contacts).

Female contacts are available with/without a shut-off valve, giving a wide range of options to suit every application.

The metal pneumatic contacts are removable without damaging the modules or the contact with the CMPES dedicated removal tool.

Moreover, they provide (see Focuses below):

- > **straight version** for use with hoods with vertical cable outlet;
- > **angled version** for use with hoods with horizontal cable outlets;
- > compatibility for tubes **up to Ø 8 mm and Ø 10 mm**.

FOCUS

Insert features: straight and angled version



- ▶ Straight and angled version available for use with different cable outlets
- ▶ With hose barbs push-over tube attachment or with quick-fitting push-in tube attachment



Watch our clip

Thermoplastic pneumatic contacts

	Tube Ø 1,6 mm		Tube Ø 3 mm		Tube Ø 4 mm		Tube Ø 6 mm	
	hose barbs (ID - inner Ø)		hose barbs (ID - inner Ø)		hose barbs (ID - inner Ø)		hose barbs (ID - inner Ø)	
	Male	Female	Male	Female	Male	Female	Male	Female
Straight <u>without</u> shut-off valve	CX 1.6 PM	CX 1.6 PF	CX 3.0 PM	CX 3.0 PF	CX 4.0 PM	CX 4.0 PF	CX 6.0 MPM	CX 6.0 MPF
Straight <u>with</u> shut-off valve		CX 1.6 PV		CX 3.0 PV		CX 4.0 PV		CX 6.0 MPV

Metal pneumatic contacts

	Tube Ø 3 mm				Tube Ø 4 mm				Tube Ø 6 mm				Tube Ø 8 mm				Tube Ø 10 mm			
	hose barbs (ID - inner Ø)		quick-fitting (OD - outer Ø)		hose barbs (ID - inner Ø)		quick-fitting (OD - outer Ø)		hose barbs (ID - inner Ø)		quick-fitting (OD - outer Ø)		hose barbs (ID - inner Ø)		quick-fitting (OD - outer Ø)		hose barbs (ID - inner Ø)		quick-fitting (OD - outer Ø)	
	Male	Female	Male	Female	Male	Female	Male	Female	Male	Female	Male	Female	Male	Female	Male	Female	Male	Female	Male	Female
Straight <u>without</u> shut-off valve	CX 3.0 MPM	CX 3.0 MPF	CX 3.0 MPQM	CX 3.0 MPQF	CX 4.0 MPM	CX 4.0 MPF	CX 4.0 MPQM	CX 4.0 MPQF	CX 6.0 MPM	CX 6.0 MPF	CX 6.0 MPQM	CX 6.0 MPQF	CX 8.0 MPM	CX 8.0 MPF	CX 8.0 MPQM	CX 8.0 MPQF	CX 10 MPM	CX 10 MPF	CX 10 MPQM	CX 10 MPQF
Straight <u>with</u> shut-off valve		CX 3.0 MPV		CX 3.0 MPQV		CX 4.0 MPV		CX 4.0 MPQV		CX 6.0 MPV		CX 6.0 MPQV		CX 8.0 MPV		CX 8.0 MPQV		CX 10 MPV		CX 10 MPQV
Angled <u>without</u> shut-off valve			CX 3.0 MPAM	CX 3.0 MPAF			CX 4.0 MPAM	CX 4.0 MPAF			CX 6.0 MPAM	CX 6.0 MPAF								
Angled <u>with</u> shut-off valve				CX 3.0 MPAV				CX 4.0 MPAV				CX 6.0 MPAV								

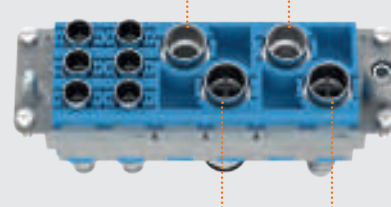
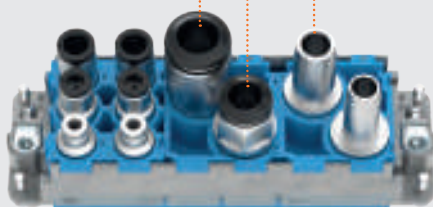
FOCUS

Compatibility for tubes up to Ø 8 mm and Ø 10 mm

- ▶ Widening of the metal pneumatic contacts series with 2 sizes available: 8.0 and 10

- ▶ Double-sized modules with 2 seats

- ▶ Female contacts without shut-off valve



- ▶ Female contacts with shut-off valve

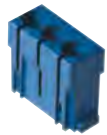
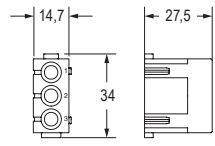
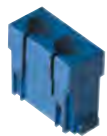
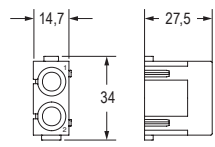
CX 03 P / CX 02 P

 size **1 module**

Inserts for thermoplastic pneumatic contacts

Insulation resistance	≥ 10 GΩ
Ambient temperature limit	-40 °C ... +80 °C
Mechanical life (cycles)	≥ 500


 CRUS[®] ECBT2.E115072 | ECBT8.E115072

Item	Description	Part No.	Dimension
	Inserts with 3 housings for tube Ø 1,6 - 3 - 4 mm Without contacts (to be ordered separately)	CX 03 P	
	Inserts with 2 housings for tube Ø 6 mm Without contacts (to be ordered separately)	CX 02 P	

MIXO

C

Materials

Insert	polycarbonate (PC)
UL 94 flame rating	V-0
Colour	blue, RAL 5015

Accessories

Accessories	Pages
MIXO Frames	
Metal frames for modular units	C.94-95
Thermoplastic docking frames	C.98-101

Enclosures


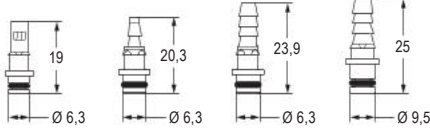

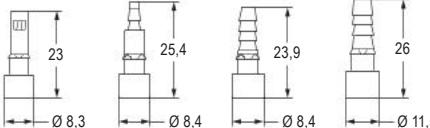

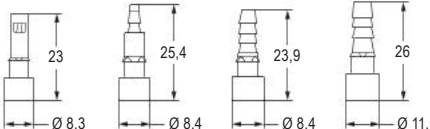
Insulating MIXO holder	C.103
MIXO ONE	C.106-107
MIXO TWO	C.110-111

- Identical male and female modular units;
- pneumatic contacts for pressure values up to 8 bar, for use with clean and dry compressed air;
- use of tubes with Ø 1,6 - 3 - 4 and 6 mm, and replacement of tubes with assembled units;
- possibility of using tubes with different diameters in the same modular unit;
- female contacts with or without closing valve;
- working temperature range:
40 °C ÷ + 80 °C;
- coding and guiding pins must be used for pneumatic contacts modules (CRM CX / CRF CX);
- these pins also provide coding if pneumatic contacts modules are used exclusively;
- the use of pneumatic contacts requires an appropriate filtering and dehydration system to prevent dangerous condensation. Contacts may be used for pressure values of up to a maximum of 8 bars/116 psi.

CX..PM/PF/VC

Thermoplastic pneumatic contacts

Insulation resistance	≥ 10 GΩ
Ambient temperature limit	-40 °C ... +80 °C
Mechanical life (cycles)	≥ 500

Item	Description	Part No.	Dimension
	Male contacts without closing valve for tubes with internal Ø 1,6 mm for tubes with internal Ø 3 mm for tubes with internal Ø 4 mm for tubes with internal Ø 6 mm	straight CX 1.6 PM CX 3.0 PM CX 4.0 PM CX 6.0 PM	
	Female contacts without closing valve for tubes with internal Ø 1,6 mm for tubes with internal Ø 3 mm for tubes with internal Ø 4 mm for tubes with internal Ø 6 mm	straight CX 1.6 PF CX 3.0 PF CX 4.0 PF CX 6.0 PF	
	Female contacts with closing valve for tubes with internal Ø 1,6 mm for tubes with internal Ø 3 mm for tubes with internal Ø 4 mm for tubes with internal Ø 6 mm	straight CX 1.6 VC CX 3.0 VC CX 4.0 VC CX 6.0 VC	

Materials

Contact	polyamide (PA)
Colour	black, RAL 9005

CX 03 MP


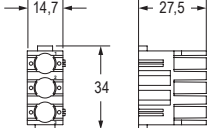
Inserts for metal pneumatic contacts

size **1 module**

Insulation resistance	≥ 10 GΩ
Ambient temperature limit	-40 °C ... +80 °C
Mechanical life (cycles)	≥ 500



(pending: cURus)

Item	Description	Part No.	Dimension
	Inserts with 3 housings for tube Ø 3 - 4 - 6 mm Without contacts (to be ordered separately)	CX 03 MP	

Materials

Insert	polycarbonate (PC)
UL 94 flame rating	V-0
Colour	blue, RAL 5015

Accessories

Accessories	Pages
MIXO Frames	
Metal frames for modular units	C.94-95
Thermoplastic docking frames	C.98-101
Enclosures	
Insulating MIXO holder	C.103
MIXO ONE	C.106-107
MIXO TWO	C.110-111

- Identical male and female modular units; female contacts with or without closing valve;
- pneumatic contacts for pressure values up to 10 bar, for use with clean and dry compressed air;
- use of tubes with Ø 3 - 4 and 6 mm, and replacement of tubes with assembled units;
- possibility of using tubes with different diameters in the same modular unit;
- coding and guiding pins must be used for pneumatic contacts modules (**CRM CX / CRF CX**);
- these pins also provide coding if pneumatic contacts modules are used exclusively;
- the use of pneumatic contacts requires an appropriate filtering and dehydration system to prevent dangerous condensation;
- available in **HNM version** up to 10.000 mating cycles.

CX..MPA/MPQ/MP

Metal pneumatic contacts

Insulation resistance	≥ 10 GΩ
Ambient temperature limit	-40 °C ... +80 °C
Mechanical life (cycles)	≥ 500

Item	Description	Part No.	Dimension												
	Quick-fitting (outer Ø) male contacts, without shut-off valve, for tube Ø 3 mm	angled CX 3.0 MPAM	<table border="1"> <thead> <tr> <th>CX .. MPAM</th> <th>A (mm)</th> <th>B (mm)</th> </tr> </thead> <tbody> <tr> <td>3.0</td> <td>43,5</td> <td>15,5</td> </tr> <tr> <td>4.0</td> <td>45,1</td> <td>18,7</td> </tr> <tr> <td>6.0</td> <td>47,5</td> <td>20,5</td> </tr> </tbody> </table>	CX .. MPAM	A (mm)	B (mm)	3.0	43,5	15,5	4.0	45,1	18,7	6.0	47,5	20,5
	CX .. MPAM	A (mm)		B (mm)											
	3.0	43,5		15,5											
4.0	45,1	18,7													
6.0	47,5	20,5													
without shut-off valve, for tube Ø 4 mm	CX 4.0 MPAM														
without shut-off valve, for tube Ø 6 mm	CX 6.0 MPAM														
	Quick-fitting (outer Ø) female contacts, without shut-off valve, for tube Ø 3 mm	angled CX 3.0 MPAF	<table border="1"> <thead> <tr> <th>CX .. MPAF</th> <th>A (mm)</th> <th>B (mm)</th> </tr> </thead> <tbody> <tr> <td>3.0</td> <td>42,4</td> <td>15,5</td> </tr> <tr> <td>4.0</td> <td>44,0</td> <td>18,7</td> </tr> <tr> <td>6.0</td> <td>46,4</td> <td>20,5</td> </tr> </tbody> </table>	CX .. MPAF	A (mm)	B (mm)	3.0	42,4	15,5	4.0	44,0	18,7	6.0	46,4	20,5
	CX .. MPAF	A (mm)		B (mm)											
	3.0	42,4		15,5											
4.0	44,0	18,7													
6.0	46,4	20,5													
without shut-off valve, for tube Ø 4 mm	CX 4.0 MPAF														
without shut-off valve, for tube Ø 6 mm	CX 6.0 MPAF														
	Quick-fitting (outer Ø) female contacts, with shut-off valve, for tube Ø 3 mm	angled CX 3.0 MPAV	<table border="1"> <thead> <tr> <th>CX .. MPAV</th> <th>A (mm)</th> <th>B (mm)</th> </tr> </thead> <tbody> <tr> <td>3.0</td> <td>49,9</td> <td>15,5</td> </tr> <tr> <td>4.0</td> <td>51,5</td> <td>18,7</td> </tr> <tr> <td>6.0</td> <td>53,9</td> <td>20,5</td> </tr> </tbody> </table>	CX .. MPAV	A (mm)	B (mm)	3.0	49,9	15,5	4.0	51,5	18,7	6.0	53,9	20,5
	CX .. MPAV	A (mm)		B (mm)											
	3.0	49,9		15,5											
4.0	51,5	18,7													
6.0	53,9	20,5													
with shut-off valve, for tube Ø 4 mm	CX 4.0 MPAV														
with shut-off valve, for tube Ø 6 mm	CX 6.0 MPAV														
	Quick-fitting (outer Ø) male contacts, without shut-off valve, for tube Ø 3 mm	straight CX 3.0 MPQM	<table border="1"> <thead> <tr> <th>CX .. MPQM</th> <th>A (mm)</th> </tr> </thead> <tbody> <tr> <td>3.0</td> <td>41,2</td> </tr> <tr> <td>4.0</td> <td>45,5</td> </tr> <tr> <td>6.0</td> <td>47,5</td> </tr> </tbody> </table>	CX .. MPQM	A (mm)	3.0	41,2	4.0	45,5	6.0	47,5				
	CX .. MPQM	A (mm)													
	3.0	41,2													
4.0	45,5														
6.0	47,5														
without shut-off valve, for tube Ø 4 mm	CX 4.0 MPQM														
without shut-off valve, for tube Ø 6 mm	CX 6.0 MPQM														
	Quick-fitting (outer Ø) female contacts, without shut-off valve, for tube Ø 3 mm	straight CX 3.0 MPQF	<table border="1"> <thead> <tr> <th>CX .. MPQF</th> <th>A (mm)</th> </tr> </thead> <tbody> <tr> <td>3.0</td> <td>40,1</td> </tr> <tr> <td>4.0</td> <td>44,4</td> </tr> <tr> <td>6.0</td> <td>46,4</td> </tr> </tbody> </table>	CX .. MPQF	A (mm)	3.0	40,1	4.0	44,4	6.0	46,4				
	CX .. MPQF	A (mm)													
	3.0	40,1													
4.0	44,4														
6.0	46,4														
without shut-off valve, for tube Ø 4 mm	CX 4.0 MPQF														
without shut-off valve, for tube Ø 6 mm	CX 6.0 MPQF														
	Quick-fitting (outer Ø) female contacts, with shut-off valve, for tube Ø 3 mm	straight CX 3.0 MPQV	<table border="1"> <thead> <tr> <th>CX .. MPQV</th> <th>A (mm)</th> </tr> </thead> <tbody> <tr> <td>3.0</td> <td>47,6</td> </tr> <tr> <td>4.0</td> <td>51,9</td> </tr> <tr> <td>6.0</td> <td>53,9</td> </tr> </tbody> </table>	CX .. MPQV	A (mm)	3.0	47,6	4.0	51,9	6.0	53,9				
	CX .. MPQV	A (mm)													
	3.0	47,6													
4.0	51,9														
6.0	53,9														
with shut-off valve, for tube Ø 4 mm	CX 4.0 MPQV														
with shut-off valve, for tube Ø 6 mm	CX 6.0 MPQV														
	Hose barbs (inner Ø) male contacts, without shut-off valve, for tube Ø 3 mm	straight CX 3.0 MPM	<table border="1"> <thead> <tr> <th>CX .. MPM</th> <th>A (mm)</th> <th>B (mm)</th> </tr> </thead> <tbody> <tr> <td>3.0</td> <td>37,6</td> <td>7,9</td> </tr> <tr> <td>4.0</td> <td>41,3</td> <td>11,6</td> </tr> <tr> <td>6.0</td> <td>40,2</td> <td>10,4</td> </tr> </tbody> </table>	CX .. MPM	A (mm)	B (mm)	3.0	37,6	7,9	4.0	41,3	11,6	6.0	40,2	10,4
	CX .. MPM	A (mm)		B (mm)											
	3.0	37,6		7,9											
4.0	41,3	11,6													
6.0	40,2	10,4													
without shut-off valve, for tube Ø 4 mm	CX 4.0 MPM														
without shut-off valve, for tube Ø 6 mm	CX 6.0 MPM														
	Hose barbs (inner Ø) female contacts, without shut-off valve, for tube Ø 3 mm	straight CX 3.0 MPF	<table border="1"> <thead> <tr> <th>CX .. MPF</th> <th>A (mm)</th> <th>B (mm)</th> </tr> </thead> <tbody> <tr> <td>3.0</td> <td>36,5</td> <td>7,9</td> </tr> <tr> <td>4.0</td> <td>40,2</td> <td>11,6</td> </tr> <tr> <td>6.0</td> <td>39,1</td> <td>10,4</td> </tr> </tbody> </table>	CX .. MPF	A (mm)	B (mm)	3.0	36,5	7,9	4.0	40,2	11,6	6.0	39,1	10,4
	CX .. MPF	A (mm)		B (mm)											
	3.0	36,5		7,9											
4.0	40,2	11,6													
6.0	39,1	10,4													
without shut-off valve, for tube Ø 4 mm	CX 4.0 MPF														
without shut-off valve, for tube Ø 6 mm	CX 6.0 MPF														
	Hose barbs (inner Ø) female contacts, with shut-off valve, for tube Ø 3 mm	straight CX 3.0 MPV	<table border="1"> <thead> <tr> <th>CX .. MPV</th> <th>A (mm)</th> <th>B (mm)</th> </tr> </thead> <tbody> <tr> <td>3.0</td> <td>39,5</td> <td>7,9</td> </tr> <tr> <td>4.0</td> <td>43,2</td> <td>11,6</td> </tr> <tr> <td>6.0</td> <td>42,1</td> <td>10,4</td> </tr> </tbody> </table>	CX .. MPV	A (mm)	B (mm)	3.0	39,5	7,9	4.0	43,2	11,6	6.0	42,1	10,4
	CX .. MPV	A (mm)		B (mm)											
	3.0	39,5		7,9											
4.0	43,2	11,6													
6.0	42,1	10,4													
with shut-off valve, for tube Ø 4 mm	CX 4.0 MPV														
with shut-off valve, for tube Ø 6 mm	CX 6.0 MPV														

Materials

Contact	nickel plated brass
---------	---------------------

CX 02 MPB

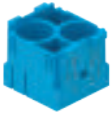
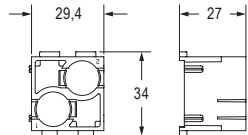
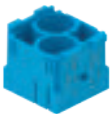
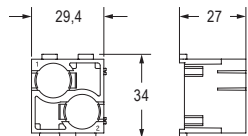
Inserts for metal pneumatic contacts

size **2 modules**

Insulation resistance	≥ 10 GΩ
Ambient temperature limit	-40 °C ... +80 °C
Mechanical life (cycles)	≥ 500

(pending: DNV and BV)

(pending: cURus)

Item	Description	Part No.	Dimension
	Male inserts with 2 housings for tube Ø 8 - 10 mm Without contacts (to be ordered separately)	CX 02 MPBM	
	Female inserts with 2 housings for tube Ø 8 - 10 mm Without contacts (to be ordered separately)	CX 02 MPBF	

Materials

Insert	polycarbonate (PC)
UL 94 flame rating	V-0
Colour	blue, RAL 5015

- Identical male and female modular units;
- pneumatic contacts for pressure values up to 10 bar, for use with clean and dry compressed air;
- use of tubes with Ø 8 and 10 mm, and replacement of tubes with assembled units;
- possibility of using tubes with different diameters in the same modular unit;
- female contacts with or without closing valve;
- working temperature range:
40 °C ÷ + 80 °C;
- coding and guiding pins must be used for pneumatic contacts modules (**CRM CX / CRF CX**);
- these pins also provide coding if pneumatic contacts modules are used exclusively;
- the use of pneumatic contacts requires an appropriate filtering and dehydration system to prevent dangerous condensation;
- available in **HNM version** up to 10.000 mating cycles.

Accessories

	Pages
MIXO Frames	
Metal frames for modular units	C.95
Thermoplastic docking frames	C.98-101

Can be used in bulkhead mounting housings or in high construction housings or in high construction hoods.

CX..MPQ/MP

Metal pneumatic contacts

Insulation resistance	≥ 10 GΩ
Ambient temperature limit	-40 °C ... +80 °C
Mechanical life (cycles)	≥ 500

Item	Description	Part No.	Dimension
	Quick-fitting (outer Ø) male contacts, without shut-off valve, for tube Ø 8 mm without shut-off valve, for tube Ø 10 mm	straight CX 8.0 MPQM CX 10 MPQM	
	Quick-fitting (outer Ø) female contacts, without shut-off valve, for tube Ø 8 mm without shut-off valve, for tube Ø 10 mm	straight CX 8.0 MPQF CX 10 MPQF	
	Quick-fitting (outer Ø) female contacts, with shut-off valve, for tube Ø 8 mm with shut-off valve, for tube Ø 10 mm	straight CX 8.0 MPQV CX 10 MPQV	
	Hose barbs (inner Ø) male contacts, without shut-off valve, for tube Ø 8 mm without shut-off valve, for tube Ø 10 mm	straight CX 8.0 MPM CX 10 MPM	
	Hose barbs (inner Ø) female contacts, without shut-off valve, for tube Ø 8 mm without shut-off valve, for tube Ø 10 mm	straight CX 8.0 MPF CX 10 MPF	
	Hose barbs (inner Ø) female contacts, with shut-off valve, for tube Ø 8 mm with shut-off valve, for tube Ø 10 mm	straight CX 8.0 MPV CX 10 MPV	

Materials

Contact	nickel plated brass
---------	---------------------

CX 01 T

Frames for modular units

1-slot sized

Mechanical life (cycles) ≥ 500

ECBT2.E115072 | ECBT8.E115072
 PVVA2.E506437 | PVVA8.E506437

Item	Description	Part No.	Dimension
	Frames for modular units for CZ enclosures	CX 01 T	

*Distance for:
 - electric and fibre optic contacts: 23,5 mm max.;
 - pneumatic contacts 23,5 mm max.

Enclosures size 49.16	Pages
Standard Heavy-Duty applications	
Metallic with IL-BRID lever	E.14-15
Metallic with JEI®-P lever	E.18
Metallic with Rigid IP67 lever	E.26
Aggressive Environments	
Metallic W-TYPE	E.28-29
Metallic E-Xtreme®	E.34-35
Specific applications	
EMC (Electromagnetic Shielding)	E.40-41
COB system for switch cabinet	E.290

- Small earth terminal for cables from 1-2,5 mm² (AWG 18-14);
 - it is recommended the use of **CRF CX / CRM CX** coding pins.

CX..T

Frames for modular units

2-slot sized – 6-slot sized



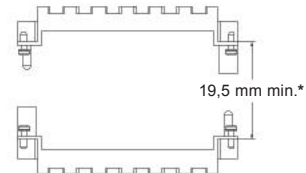
Mechanical life (cycles) ≥ 500

ECBT2.E115072 | ECBT8.E115072
PVVA2.E506437 | PVVA8.E506437

Item	Description	Part No.	Dimension															
	<p>Frames for modular units for 2 modular units, size 44.27 for 3 modular units, size 57.27 for 4 modular units, size 77.27 – 77.62 for 6 modular units, size 104.27 – 104.62</p> <p>Supplied with lock-in tab</p> <p>Assignment of attribute “for hoods” is merely conventional: this type can be mounted either in a hood or in a housing. In a modular connector coupling there shall be always a male frame and female type</p>	<p>Type for hoods CX 02 TM CX 03 TM CX 04 TM CX 06 TM</p>	 <table border="1"> <thead> <tr> <th>Part No.</th> <th>A (mm)</th> <th>for hoods size</th> </tr> </thead> <tbody> <tr> <td>CX 02 TM</td> <td>44</td> <td>44.27</td> </tr> <tr> <td>CX 03 TM</td> <td>57</td> <td>57.27</td> </tr> <tr> <td>CX 04 TM</td> <td>77,5</td> <td>77.27 and 77.62</td> </tr> <tr> <td>CX 06 TM</td> <td>104</td> <td>104.27 and 104.62</td> </tr> </tbody> </table>	Part No.	A (mm)	for hoods size	CX 02 TM	44	44.27	CX 03 TM	57	57.27	CX 04 TM	77,5	77.27 and 77.62	CX 06 TM	104	104.27 and 104.62
Part No.	A (mm)	for hoods size																
CX 02 TM	44	44.27																
CX 03 TM	57	57.27																
CX 04 TM	77,5	77.27 and 77.62																
CX 06 TM	104	104.27 and 104.62																
	<p>Frames for modular units, for housings for 2 modular units, size 44.27 for 3 modular units, size 57.27 for 4 modular units, size 77.27 – 77.62 for 6 modular units, size 104.27 – 104.62</p> <p>Supplied with lock-in tab</p> <p>Assignment of attribute “for housings” is merely conventional: this type can be mounted either in a hood or in a housing. In a modular connector coupling there shall be always a male frame and female type</p>	<p>Type for housings CX 02 TF CX 03 TF CX 04 TF CX 06 TF</p>	 <table border="1"> <thead> <tr> <th>Part No.</th> <th>A (mm)</th> <th>for housings size</th> </tr> </thead> <tbody> <tr> <td>CX 02 TF</td> <td>44</td> <td>44.27</td> </tr> <tr> <td>CX 03 TF</td> <td>57</td> <td>57.27</td> </tr> <tr> <td>CX 04 TF</td> <td>77,5</td> <td>77.27 and 77.62</td> </tr> <tr> <td>CX 06 TF</td> <td>104</td> <td>104.27 and 104.62</td> </tr> </tbody> </table>	Part No.	A (mm)	for housings size	CX 02 TF	44	44.27	CX 03 TF	57	57.27	CX 04 TF	77,5	77.27 and 77.62	CX 06 TF	104	104.27 and 104.62
Part No.	A (mm)	for housings size																
CX 02 TF	44	44.27																
CX 03 TF	57	57.27																
CX 04 TF	77,5	77.27 and 77.62																
CX 06 TF	104	104.27 and 104.62																

Polarisation of frames with relative identification letters and couplings

frames	size 44.27	size 57.27	size 77.27 – 77.62	size 104.27 – 104.62
for hoods				
for housings				



*Distance for:
- electric and fibre optic contacts: 20,5 mm max.;
- pneumatic contacts 20,5 mm max.

The module support frames are marked:
- hoods: **A-B** (44.27), **A-C** (57.27), **A-D** (77.27) and **A-F** (104.27)
- housings: **a-b** (44.27), **a-c** (57.27), **a-d** (77.27) and **a-f** (104.27)

Positioning the modules in the frames according to the respective letters is ensuring the specular assembly of modules, for which the hood will be coupled correctly to the housing.

Enclosures sizes	Pages
44.27, 57.27, 77.27, 104.27 and 77.62, 104.62	E.48-303


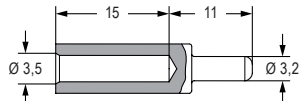

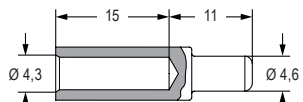

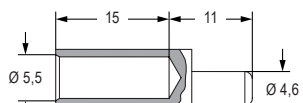

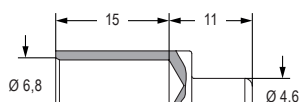

Earth terminal
- large: for cables from 4-6 mm², AWG 12-10
- small: for cables from 1-2,5 mm², AWG 18-14

In order to accommodate larger PE conductor cross-sectional area, use **CGT PE** adapters, see page [C.84](#)

It is recommended the use of **CRF CX / CRM CX** coding pins.

CGT

PE terminal adapters for MIXO frames

Item	Description	Part No.	Dimension
	PE wire terminal adapter 6 mm ² (10 AWG) Cannot be used with T-TYPE surface mounting housings and horizontal cable outlet hoods.	CGT 6.0	
	PE wire terminal adapter 10 mm ² (8 AWG) Cannot be used with T-TYPE surface mounting housings and horizontal cable outlet hoods.	CGT 10	
	PE wire terminal adapter 16 mm ² (6 AWG) Cannot be used with T-TYPE surface mounting housings and horizontal cable outlet hoods.	CGT 16	
	PE wire terminal adapter 25 mm ² (4 AWG) Cannot be used with T-TYPE surface mounting housings and horizontal cable outlet hoods.	CGT 25	
	Headless screw M4×6, stainless steel, kit of 10 pcs. For the use with T-TYPE bulkhead housings and vertical entry hoods it is needed to replace the M4 screw of the 6 mm ² PE contact of the frame with the headless screw CR VGM4	CR VGM4	

Materials

PE terminals nickel-plated brass

How to use the PE adapters:

- 1) Strip 15 mm of flexible PE protective cable.
- 2) Crimp the cable on the CGT adapter by using the **CPPZ C** pliers with the **CGD 10 C** dies for 6 mm² and 10 mm², **CGD 16 C** dies for 16 mm² and **CGD 25 C** dies for 25 mm².
- 3) Fix the adapter tip in the larger earth terminal (6 mm²) for **CGT 10**, **CGT 16**, **CGT 25** or in the smaller earth terminal (2,5 mm²) for **CGT 6.0** of frames CX...TM/TF.

Accessories

Pages

MIXO Frames


Metal frames for modular units

C.94-95

CR..DF

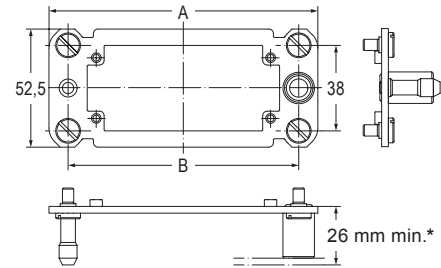
Stainless-steel self-centring floating frames

Mechanical life (cycles)	≥ 500
Compensation range	
- x axis	± 1,5 mm
- y axis	± 1,5 mm

Item	Description
	<p>Stainless steel frame, to be mounted on: inserts size 44.27 and MIXO frames, 2 inserts inserts size 57.27 and MIXO frames, 3 inserts inserts size 77.27 and MIXO frames, 4 inserts inserts size 104.27 and MIXO frames, 6 inserts</p> <p>Cannot be used with CT, CTS and CTSE inserts</p> <p>Supplied with 4 M5 shoulder screws with cylindrical head and notch to fix the frame in place</p> <p>As the frames are floating, the PE earthing connection of the metal surfaces on which they are mounted (mounting bases) must be performed separately and cannot be done by connecting the PE earthing contact to the corresponding connector inserts.</p>

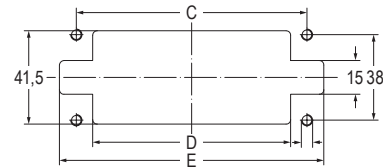
Part No. Dimension

[CR 06 DF](#)
[CR 10 DF](#)
[CR 16 DF](#)
[CR 24 DF](#)



*Distance for:
 - electric and fibre optic contacts: 26,5 mm max. ;
 - pneumatic contacts: 26,5 mm max.

panel cut-out



Part No.	A (mm)	B (mm)	C (mm)	D (mm)	E (mm)
CR 06 DF	86	69	69	54,5	84
CR 10 DF	99	82	82	67,5	97
CR 16 DF	119,5	102,5	102,5	88	117,5
CR 24 DF	146	129	129	114,5	144

Materials

Floating frame	stainless steel
Fixing screws	zinc-plated steel

Designed to be used in the transportation, printing and power electronic industries (for example boxes for rack cabinets) and in all industrial applications that require, during assembly or maintenance, the connection of connectors without possibility of controlling the alignment.

Enables the self-centring coupling of two corresponding connectors without the use of enclosures; they freely move on their base plate (± 1,5 mm on both axes) ensuring the alignment of the coupling.

CX 02 PD

Thermoplastic docking frames

2-slot sized

EN 60529 rating	IP2X (IPXXB)
UL 50 / UL 50E	
Ambient temperature limit	-40 °C ... +125 °C
Mechanical life when fitted with MIXO modules (cycles)	≥ 500

(pending: CQC, DNV and BV)

(pending: cURus)

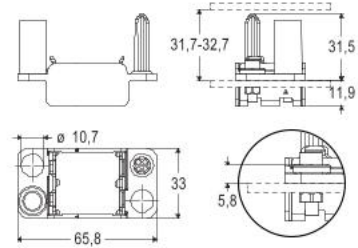
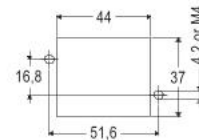
Item	Description	Part No.	Dimension
------	-------------	----------	-----------



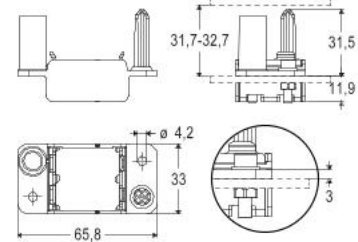
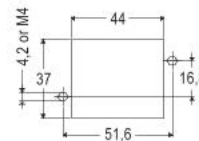
Float-mount thermoplastic insulating docking frame for 2 modular units

* supplied with 2x floating washers to enable the frame to be float-mounted using standard M4 fixing screws (not supplied)

The leading centring system compensates for tolerances of ± 2 mm both in x and y axes.

[CX 02 PDM](#)

Panel cut-out


Fixed-mount thermoplastic insulating docking frame for 2 modular units

[CX 02 PDF](#)

Panel cut-out


Materials

Frame	polycarbonate (PC)
UL 94 flame rating	V-0
Colour	pebble grey, RAL 7032



CX 01 PEF/PEM

1-slot sized PE module for thermoplastic docking frames
Page [C.27](#)

CX 03 PD


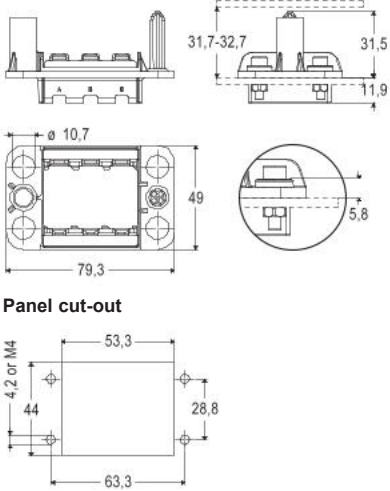

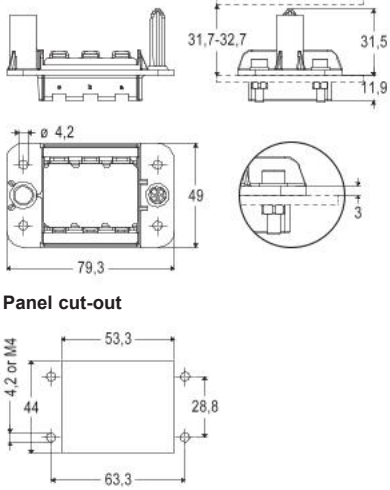
Thermoplastic docking frames

3-slot sized

EN 60529 rating	IP2X (IPXXB)
UL 50 / UL 50E	
Ambient temperature limit	-40 °C ... +125 °C
Mechanical life when fitted with MIXO modules (cycles)	≥ 500

(pending: CQC, DNV and BV)

(pending: cURus)

Item	Description	Part No.	Dimension
	Float-mount thermoplastic insulating docking frame for 3 modular units * supplied with 4× floating washers to enable the frame to be float-mounted using standard M4 fixing screws (not supplied) The leading centring system compensates for tolerances of ± 2 mm both in x and y axes.	CX 03 PDM	
	Fixed-mount thermoplastic insulating docking frame for 3 modular units	CX 03 PDF	

Materials

Frame	polycarbonate (PC)
UL 94 flame rating	V-0
Colour	pebble grey, RAL 7032



CX 01 PEF/PEM

1-slot sized PE module for thermoplastic docking frames
Page [C.27](#)

CX 04 PD

Thermoplastic docking frames

4-slot sized

EN 60529 rating	IP2X (IPXXB)
UL 50 / UL 50E	
Ambient temperature limit	-40 °C ... +125 °C
Mechanical life when fitted with MIXO modules (cycles)	≥ 500

(pending: CQC, DNV and BV)

(pending: cURus)

Item	Description	Part No.	Dimension
------	-------------	----------	-----------

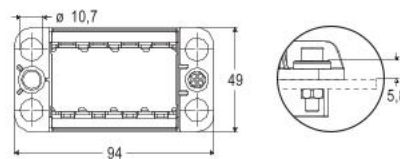
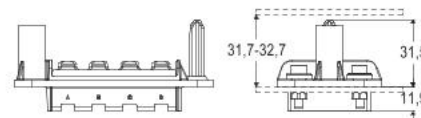


Float-mount thermoplastic insulating docking frame for 4 modular units

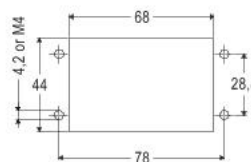
[CX 04 PDM](#)

* supplied with 4x floating washers to enable the frame to be float-mounted using standard M4 fixing screws (not supplied)

The leading centring system compensates for tolerances of ± 2 mm both in x and y axes.

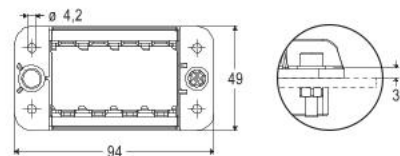
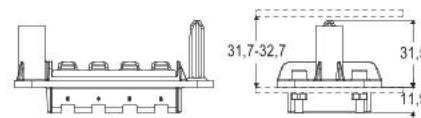


Panel cut-out

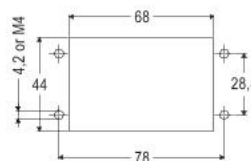


Fixed-mount thermoplastic insulating docking frame for 4 modular units

[CX 04 PDF](#)



Panel cut-out



Materials

Frame	polycarbonate (PC)
UL 94 flame rating	V-0
Colour	pebble grey, RAL 7032



CX 01 PEF/PEM
1-slot sized PE module for thermoplastic docking frames
Page [C.27](#)

CX 06 PD


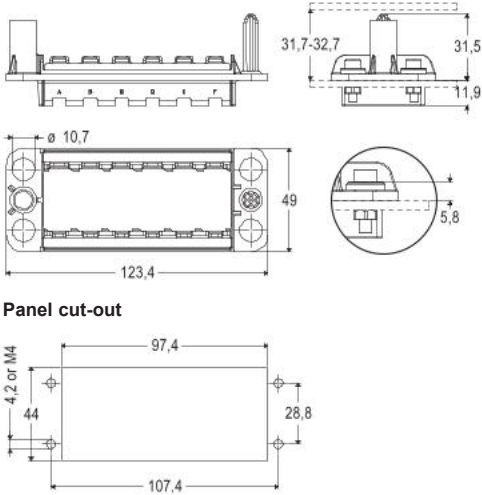

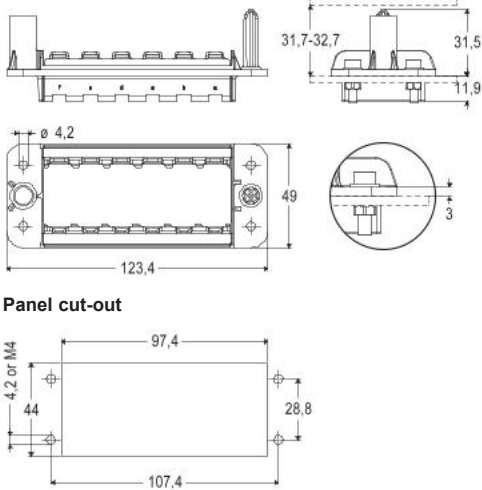
Thermoplastic docking frames

6-slot sized

EN 60529 rating	IP2X (IPXXB)
UL 50 / UL 50E	
Ambient temperature limit	-40 °C ... +125 °C
Mechanical life when fitted with MIXO modules (cycles)	≥ 500

(pending: CQC, DNV and BV)

(pending: cURus)

Item	Description	Part No.	Dimension
	Float-mount thermoplastic insulating docking frame for 6 modular units * supplied with 4x floating washers to enable the frame to be float-mounted using standard M4 fixing screws (not supplied) The leading centring system compensates for tolerances of ± 2 mm both in x and y axes.	CX 06 PDM	
	Fixed-mount thermoplastic insulating docking frame for 6 modular units	CX 06 PDF	

Materials

Frame	polycarbonate (PC)
UL 94 flame rating	V-0
Colour	pebble grey, RAL 7032




CX 01 PEF/PEM


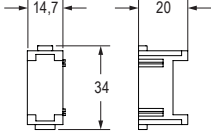
1-slot sized PE module for thermoplastic docking frames
Page [C.27](#)



CX FM

Dummy module

size **1 module**
 ECBT2.E115072 | ECBT8.E115072

Item	Description	Part No.	Dimension
	<p>Dummy module for unused frame seats</p> <p>This version is formed by a single piece and has a reduced weight.</p> <p>It allows the mating of a MIXO insert including it with a corresponding MIXO insert even having, in front of the dummy module, a regular male or female module equipped with contacts, which obviously will not work.</p> <p>The sole exceptions to this feature are that an insert with this dummy module cannot mate an inserts showing in front a CX 3/4 XDF/M, CX 04 XF/M or CX 02 HF modules.</p>	CX FM	

MIXO

C

Materials

Insert	polycarbonate (PC)
UL 94 flame rating	V-0
Colour	pebble grey, RAL 7032

Accessories**Pages****MIXO Frames**

Metal frames for modular units	C.95
Thermoplastic docking frames	C.98-101

Individual modules with a width of 14,7 mm can be installed in plastic supports.

CX 01 TP/CX APE

Insulating MIXO holder and adapter for DIN rails


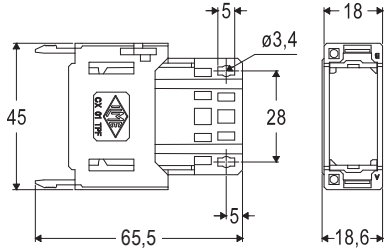

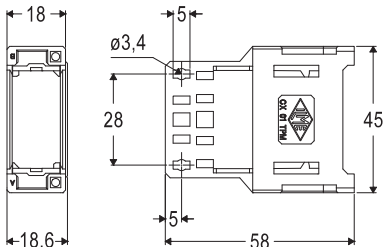

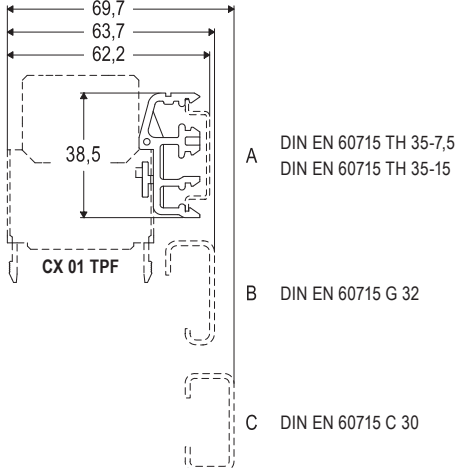


Watch our clip

EN 60529 rating	IP2X (IPXXB)
UL 50 / UL 50E	—
Ambient temperature limit	-40 °C ... +125 °C
Mechanical life (cycles)	≥ 500

(pending: CQC, DNV and BV)

(pending: cURus)

Item	Description	Part No.	Dimension
	Insulating fixed holder for 1-slot sized MIXO modules	CX 01 TPF	
	Insulating free holder for 1-slot sized MIXO modules	CX 01 TPM	
	Adapter for attachment to DIN EN 60715 rails To be used with CX 01 TPF insulating fixed holder	CX APE	

Materials

Holder	polycarbonate (PC)
UL 94 flame rating	V-0
Colour	pebble grey, RAL 7032



CR Q03/2
Coding pins
Page G.7

MIXO ONE for 1 single-slot sized MIXO module



MIXO ONE is the aluminium housing system designed by ILME to accept the wide range of MIXO series **single-sized** modules.

These robust connector enclosures (3 hood variants and 1 bulkhead mounting housing) transform each single MIXO module into a completely independent connector.



Watch our clip

MIXO ONE CXA 01 / MXA 01 overview

The enclosures allow only mounting of a single MIXO module in one guided way.

A pre-leading (first-make, last-break) PE connection terminal is incorporated in the housing for the safest connector operation to avoid an incorrect match with the mating connector.

The pins protruding from the bulkhead mounting housing also act as key guides, in cooperation with the corresponding keyway sockets in the hoods, to avoid incorrect 180° reversed mating with the corresponding connector.

SUM-UP

- > Hoods split in two parts (front, rear), to allow MIXO module mounting and simplify the enclosure's PE connection. Supplied with four self-threading screws and self-retaining sealing gasket.
- > The bulkhead mounting housing is supplied with the module locking frame and self-retaining flange gasket.
- > Four optional coding pins available for up to 16 different codings, as a provision against mismatching when identical connectors are installed side by side.
- > Protection covers for hoods and housings, either with pegs (for enclosures with locking lever and sealing gasket) or with locking lever and sealing gasket (for enclosures with pegs) available either with eyelet terminated string (for fastening to housings) or with loop-terminated cord (for fastening to hoods, around the incoming cable).

FOCUS

Housings' technical features



- ▶ **Robust and compact design** for a new modules concept




- ▶ **Up to 16 different codings** option (2 coding pins per both bulkhead mounting housing and hoods)

MIXO ONE – for 1 single MIXO module

size **1 module**

Housings, hoods and covers – 1 lever and 2 pegs


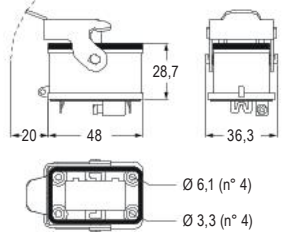

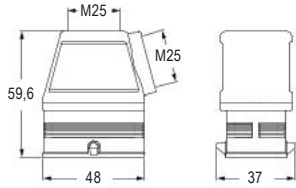

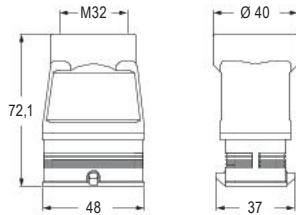



Heavy-Duty Applications 

EN 60529	IP65
UL 50 / UL 50E	Type 12 / 4 / 4X
Ambient temperature limits	-40 °C ... +125 °C
Mechanical life (cycles)	≥ 500

CE UK

DNV VERITAS

CBUS ECBT2.E115072 | ECBT8.E115072

Item	Description	Part No.	Entry	Dimension
	Bulkhead mounting housings, one lever and gasket	CXA 01 I		
	Hoods, 2 pegs, side or top entry (in 2 parts)	Side Entry MXA 01 O25	Top Entry MXA 01 V25	M25 
	Hoods, 2 pegs, top entry	MXA 01 V32	M32	
	Plastic covers, with 1 lever and gasket - with loop 	CXP 01 CLG		
	Plastic covers, with 2 pegs - with eyelet 	CXP 01 C		

Inserts	Pages
single-sized MIXO modular units	C.21-90

PE terminal: on both the bulkhead mounting housing and on the hood front part, PE screw terminal without protection plate, zinc plated steel terminal screw with rounded tip.
 Connecting capacity: 0,5 mm² (20 AWG) - 10 mm² (8 AWG) both unprepared and prepared stranded copper wire.
 PE terminal screw head footprint: for Ph1 or 1,0x5,5 mm flat screwdriver, recommended torque 1,2 Nm (10,6 lb.in).

Some regulations may require conductor preparation with a crimped end sleeve. Recommended crimp shape: square, e.g. by using Rennsteig ferrule crimping pliers PEW 8.85 (610 1853).



CR CX

Coding pins

size **1 module**


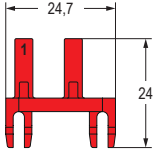

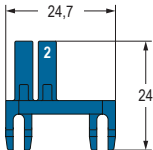

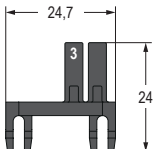

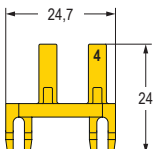
Heavy-Duty Applications



CE UK CA



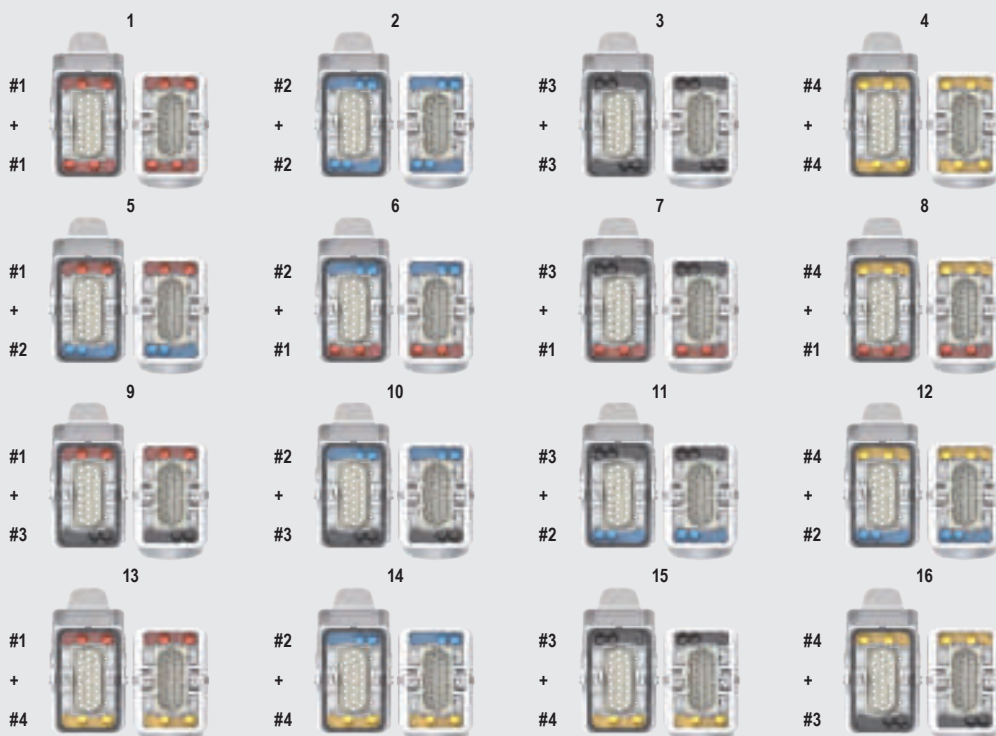
CALUS[®] ECBT2.E115072 | ECBT8.E115072

Item	Description	Part No.	Dimension
	Red plastic coding pin, 16 codings (#1)	CR CX01R	
	Blue plastic coding pin, 16 codings (#2)	CR CX01B	
	Black plastic coding pin, 16 codings (#3)	CR CX01N	
	Yellow plastic coding pin, 16 codings (#4)	CR CX01G	

MIXO ONE

C

CR CX01.. coding options



MIXO TWO

for 2 single-slot sized MIXO module



MIXO TWO is the compact metal enclosure system designed by ILME to accept **two** of the wide range of MIXO series single-sized modules.

These robust zinc die-cast connector enclosures are available as bulkhead, angled bulkhead mounting housings, and four hood variants, differing by the position and size of the cable entry: M25 or M32, horizontal or vertical.

Together, they transform two suitable single-sized MIXO modules that can be chosen to form a myriad of combinations into a completely independent and compact connector.

MIXO TWO CXA 02 / MXA 02 overview

Each MIXO TWO enclosure comes with a dedicated two-slot MIXO frame which incorporates sliding captive module locking tabs and, in the middle, a pre-leading (first-make, last-break) PE contact with relevant screw terminal for the safest connector operation.

The housing of two single-sized MIXO modules is allowed in a guided way, avoiding incorrect match with a correspondingly mating connector assembly inside the counterpart MIXO TWO enclosure.

The complete connectors using MIXO TWO enclosures result polarized to avoid incorrect 180° reversed mating with corresponding connector.



Watch our clip

Installation advantages

The series MIXO TWO of metallic enclosures for modular connector inserts is the natural complement of series MIXO ONE.

Where the last one provided a compact protective solution to transform one single-sized MIXO connector module into a complete connector, MIXO TWO enclosures do the same with two single-sized series MIXO connector modules, giving the chance to obtain a 2-module complete connector in a more compact space than by using size 44.27 standard hood and housing and relevant MIXO frames.



SUM-UP

- > Zinc die cast alloy, thermosetting powder coated bulkhead mounting housing with IL-BRID locking lever, with stainless steel core, releasably mounted on moulded pegs, and flange and interface NBR sealing gaskets, glued on bottom and top contours.
- > Zinc die cast alloy, thermosetting powder coated hoods in one part, to allow simpler MIXO module mounting thanks to the separate modules holding frame that provides the PE connection.
- > Zinc die cast alloy modules holding frame with pre-leading PE contact (female on the hoods, male on the bulkhead mounting housing) for enclosure's equipotential bonding to earth, for fixing the assembly of frame + modules to either the panel or the hood; available either with eyelet terminated string (for fastening to housings) or with loop-terminated cord (for fastening to hoods, around the incoming cable).

FOCUS

Housing's technical features

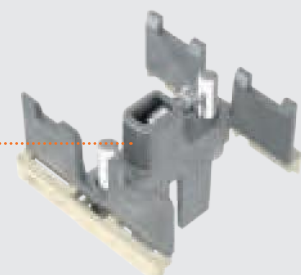


- ▶ **Single-piece** zinc die cast alloy, thermosetting powder coated hoods, available with **M25** or **M32** large cable entry

▶ **M25** or **M32** large cable entry available for both bulkhead and surface mounting housings

▶ **Single-piece** zinc die cast alloy, thermosetting powder coated bulkhead and surface mounting housing

- ▶ **Improved PE screw terminal** accepting up to 10 mm² prepared wire (no special tool required) or 16 mm² with CG 16 PE adapter



MIXO TWO – for 2 single MIXO modules

Housings – 1 lever

size 2 modules

Heavy-Duty
Applications


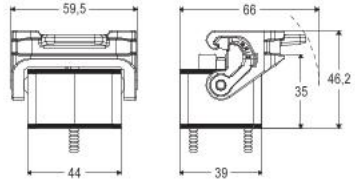

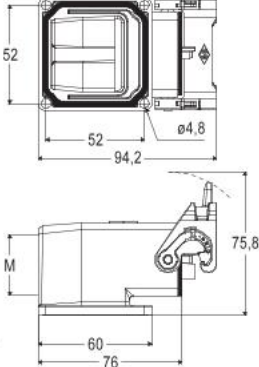

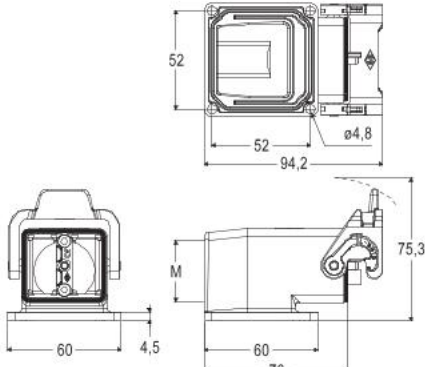


CE UK
CA

EN 60529	IP65
UL 50 / UL 50E	Type 12 / 4 / 4X
Ambient temperature limits	-40 °C ... +125 °C
Mechanical life (cycles)	≥ 500

(pending: CQC, DNV and BV)

(pending: cURus)

Item	Description	Part No.	Entry	Dimension
	<p>Bulkhead metal mounting housings, 1 lever and gasket</p> <p>Supplied with frame with captive lock-in tabs</p>	CXA 02 I		
	<p>Angled bulkhead metal mounting housings, 1 lever and gasket, with <u>open bottom flange</u> with embedded gasket and closed rear</p>	CXA 02 IA		
	<p>Angled bulkhead metal mounting housings, 1 lever and gasket, with <u>open bottom flange</u> with embedded gasket and cable entry</p>	<p>MXA 02 IAP25 MXA 02 IAP32</p>	<p>M25 M32</p>	
	<p>Angled surface metal mounting housings, 1 lever and gasket, with <u>closed bottom flange</u> (without gasket) and cable entry</p>	<p>MXA 02 AP25 MXA 02 AP32</p>	<p>M25 M32</p>	

Inserts

single-sized MIXO modular units

Pages

[C.21-90](#)

MIXO TWO – for 2 single MIXO modules

size 2 modules

Hoods and covers – 1 lever and 2 pegs

Heavy-Duty
Applications


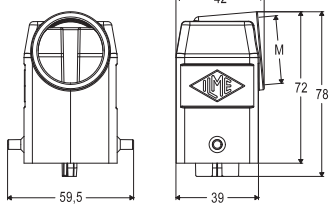
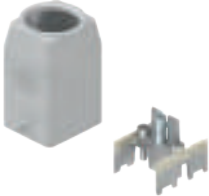
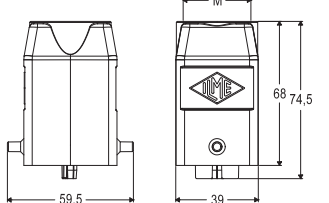


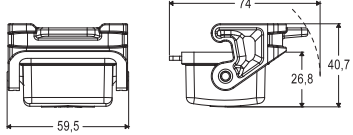


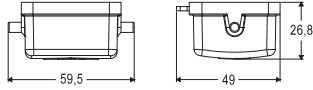


CE UK

(pending: CQC, DNV and BV)

(pending: cURus)

EN 60529	IP65
UL 50 / UL 50E	Type 12 / 4 / 4X
Ambient temperature limits	-40 °C ... +125 °C
Mechanical life (cycles)	≥ 500

Item	Description	Part No.	Entry	Dimension
	Hoods, 2 pegs, side entry Supplied with frame with captive lock-in tabs	MXA 02 O25 MXA 02 O32	M25 M32	
	Hoods, 2 pegs, top entry Supplied with frame with captive lock-in tabs	MXA 02 V25 MXA 02 V32	M25 M32	
	Plastic covers, with 1 lever and gasket - with loop 	CXP 02 CLG		
	Plastic covers, with 2 pegs - with eyelet 	CXP 02 C		

Inserts	Pages
single-sized MIXO modular units	C.21-90

Panel cut-out drawings

For MIXO ONE bulkhead mounting housings

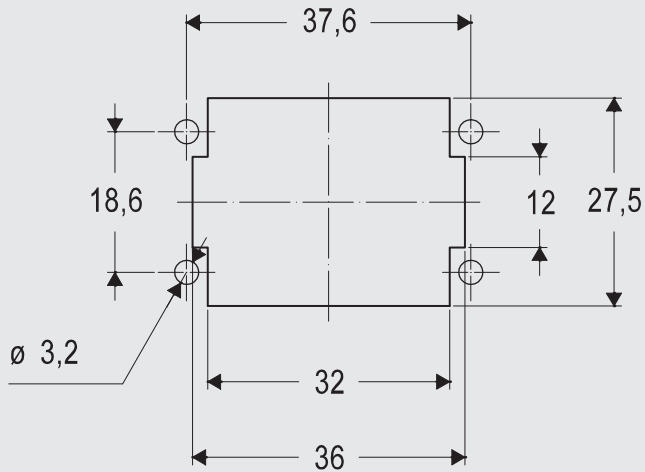
To guarantee the declared IP degree of protection of the housings reported in this catalogue, according to EN IEC 60529 or to the relevant Type rating per ANSI/UL 50 and 50E (for those products bearing approval to those ratings), the surface of the mounting panel must meet the following requirements (definitions are provided in ISO 4287 standard):

Waviness $Wt \leq 0,2$ mm over a distance of 200 mm
(measured on the panel without load)

Roughness $Ra \leq 16$ μm

Scale 1:1

MIXO ONE bulkhead mounting housings



Screws N°: 4

Screws size: M3

Recommended torque:

0,5 – 0,9 Nm / 4.4 – 8.0 lb.in

The values of tightening torque indicated above are just recommended values, that must be related – by the designer of the final application – to the resistance class of the screws (not included), with the assumption that the mounting panel is sufficiently rigid (stiff).

Panel cut-out drawings

For MIXO TWO bulkhead mounting housings

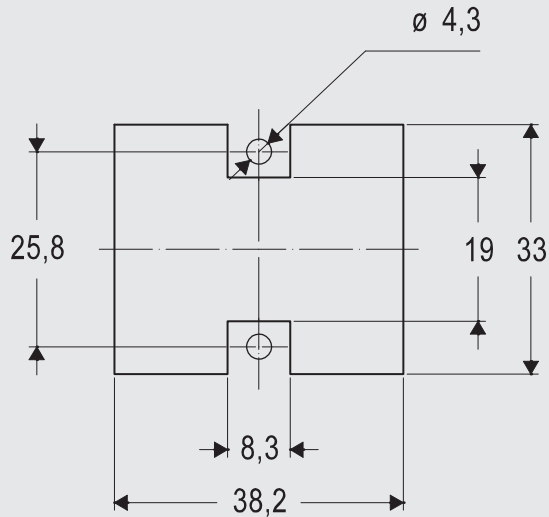
To guarantee the declared IP degree of protection of the housings reported in this catalogue, according to EN IEC 60529 or to the relevant Type rating per ANSI/UL 50 and 50E (for those products bearing approval to those ratings), the surface of the mounting panel must meet the following requirements (definitions are provided in ISO 4287 standard):

Waviness $Wt \leq 0,2$ mm over a distance of 200 mm
(measured on the panel without load)

Roughness $Ra \leq 16$ μ m

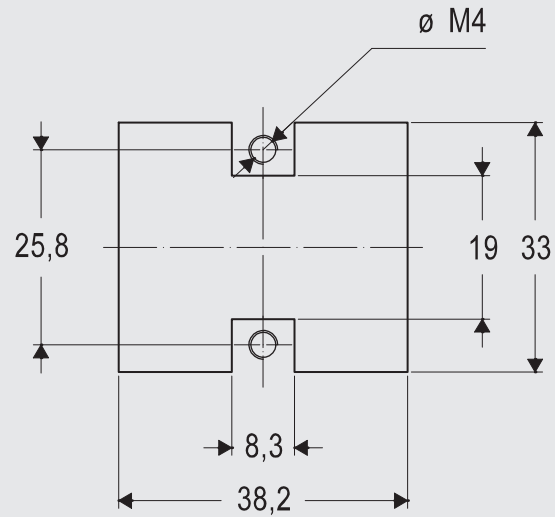
Scale 1:1

**MIXO TWO bulkhead mounting housings
through-holes panel (max. thickness: 6 mm)**

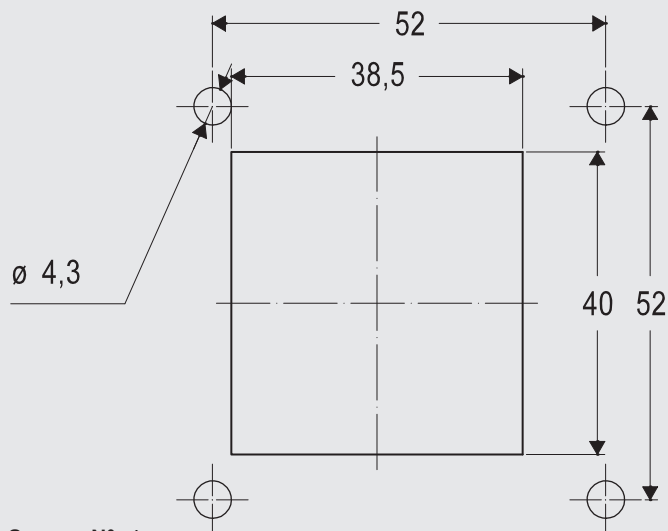


Screws N°: 2
Screws size: M4
Recommended torque:
0,8 – 1,2 Nm / 7.1 – 10.6 lb.in

**MIXO TWO bulkhead mounting housings
threaded panel**

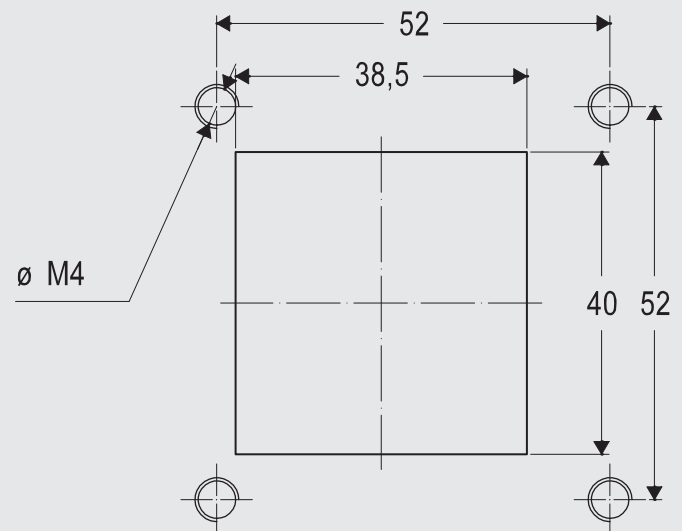


**MIXO TWO angled bulkhead mounting housings
through-holes panel**



Screws N°: 4
Screws size: M4
Recommended torque:
0,8 – 1,2 Nm / 7.1 – 10.6 lb.in

**MIXO TWO angled bulkhead mounting housings
threaded panel**






The values of tightening torque indicated above are just recommended values, that must be related – by the designer of the final application – to the resistance class of the screws (not included), with the assumption that the mounting panel is sufficiently rigid (stiff).

GENERAL CATALOGUE

PCB adapters for inserts

Contents

For inserts CQ series size 21.21 	CIF Q05 / CIF Q07		<i>D.2</i>
	- 10 A solder connection	D.4	
	- 7,5 A solder connection	D.4	
	CIF Q12		
	- 7,5 A solder connection	D.6	
For inserts CQ series size 32.13 	CIF Q4/2 / CIF Q08		<i>D.8</i>
	- 30 A solder connection	D.10	
	- 16 A solder connection	D.10	
For inserts CDD, CX and MIXO series 	CIF 2.4 / CIF 5 2.4 / CIF X17 2.4		<i>D.12</i>
	- 7,5 A solder connection	D.14	

PCB adapters for inserts

CQ series size 21.21



D

The ILME PCB adapters CIF series allows cable-to-PCB connection with CQ, CDD, CX and MIXO series industrial heavy-duty connector inserts for power electronics and signal applications, reducing wiring costs (where “large numbers” justify the development of a PCB design).

Connectorization minimises downtime in factory automation due to the easy replacement of modular PCB circuitry (more accessible and faster maintenance).

CQ series size 21.21

CIF Q07 2.4

The CIF Q07 2.4 PCB interface adapter is suitable for printed circuit board application by soldering to PCBs with thickness up to 2,4 mm, allowing cable to printed circuit board connection with CQ 07 7P + ⊕ inserts.

For the connection to the PCB adapter of CQ 07 inserts, it is necessary to equip these standard inserts with special interface contacts:

- > **CDFA 6A28 - 7,5 A** female interface contacts for CQF 07
- > **CDMA 6A - 7,5 A** male interface contacts for CQM 07



Due to the contact pitch and the layout pattern on the PCB, a reduction of rated voltage for CQ 07 insert is required from 400 V to 250 V.

CIF Q05 2.4

The CIF Q05 2.4 PCB interface adapter is suitable for printed circuit board application by soldering to PCBs with thickness up to 2,4 mm, allowing cable to printed circuit board connection with CQ 05 5P + ⊕ inserts.

For the connection to the PCB adapter of CQ 05 inserts, it is necessary to equip these standard inserts with special interface contacts:

- > **CCFFA - 16 A** female interface contacts for CQF 05
- > **CCMFA - 16 A** male interface contacts for CQM 05



Due to the contact pitch and the layout pattern on the PCB, a reduction of rated voltage for CQ 05 insert is required from 250/400 V to 250 V.

CIF Q12 2.4

The CIF Q12 2.4 PCB interface adapter is suitable for printed circuit board applications by soldering to PCBs with thickness up to 2.4 mm, allowing cable-to-printed circuit board connection with CQ 12 12P + ⊕ inserts.

Special CQ 12 inserts have been designed for the connection to the PCB adapter, CQF 12 CIF and CQM 12 CIF, both with PE contacts equipped with a rear Ø 1 mm pin for mating with the PE contact of the PCB adapter.

The CIF Q12 2.4 PCB must be equipped with special interface contacts:

- > **CDFA 6A28 - 7,5 A** female interface contacts for CQF 12 CIF
- > **CDMA 6A - 7,5 A** male interface contacts for CQM 12 CIF



Due to the contact pitch and the layout pattern on the PCB, a reduction of rated voltage for CQ 12 is required from 400/690 V to 250 V.

CIF Q05 2.4 / CIF Q07 2.4**10 A – 250 V****7,5 A – 250 V**size **21.21****5 poles****7 poles****Solder connection**

EN 61984 rating


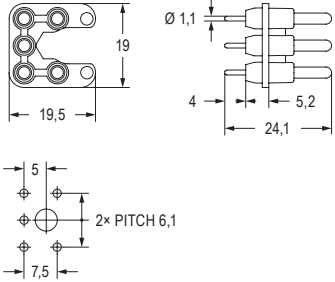

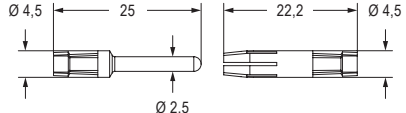


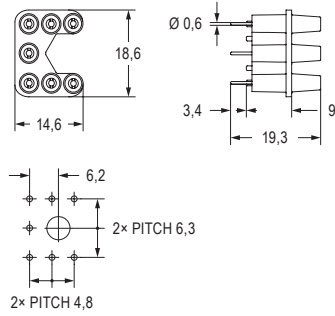

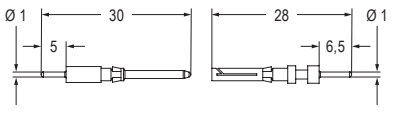

- CIF Q05 2.4 10 A 250 V 4 kV 3

- CIF Q07 2.4 7,5 A 250 V 4 kV 3

Ambient temperature limit -40 °C ... +125 °C



CFLUS® ECBT2.E115072 | ECBT8.E115072

Item	Description	Part No.	Dimension
	PCB interface adapter For CQ 05 inserts For up to 2,4 mm thick PCB	CIF Q05 2.4	
	16 A male interface contacts for male insert	CCMFA	
	16 A female interface contacts for female insert	CCFFA	
	PCB interface adapter For CQ 07 inserts For up to 2,4 mm thick PCB	CIF Q07 2.4	
	7,5 A male interface contacts for male insert	CDMA 6A	
	7,5 A female interface contacts for female insert	CDFA 6A28	

Materials

Insert	polycarbonate (PC)
UL 94 flame rating	V-0
Colour	pebble grey, RAL 7032
Contacts	copper alloy, silver ● plated

Compact 21.21 Inserts	Poles	Pages
CIF Q05 2.4		
CQ 05	16 A	5 + ⊕ A.8
CIF Q07 2.4		
CQ 07	10 A	7 + ⊕ A.10

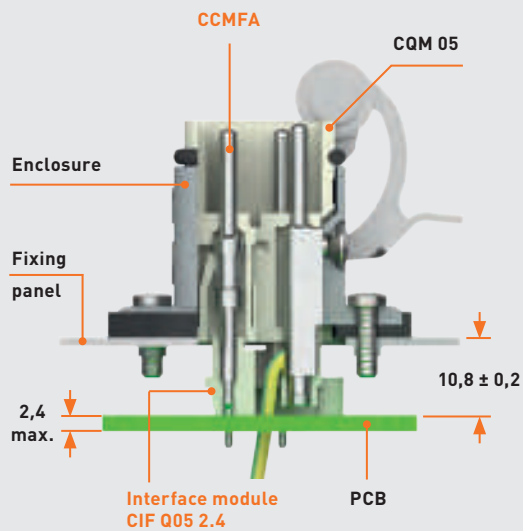
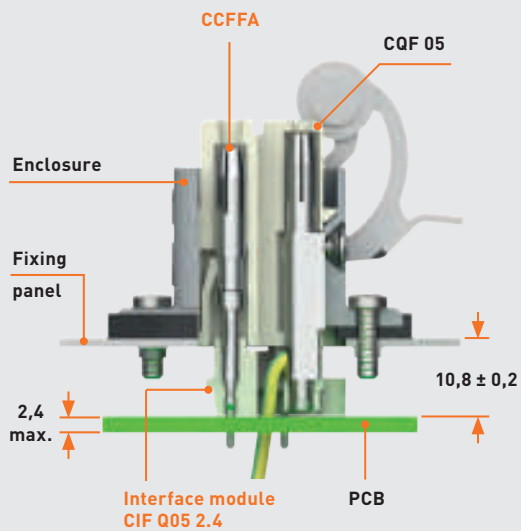
CAUTION – The layout of the PCB for this adapter must foresee a suitable pass-through hole for the PE wiring coming from the screw-type PE terminal of CQF /M 05 connector. This adapter does not foresee a PE connection. It is important to fulfil the continuity of PE connection of the CQF /M 05 connector, also for the possibility to use a metal housing that must be connected to the PE circuit.

The adapter is soldered on the printed circuit on which the multipole connector (male or female) equipped with interface contacts will be inserted.

CQM 05



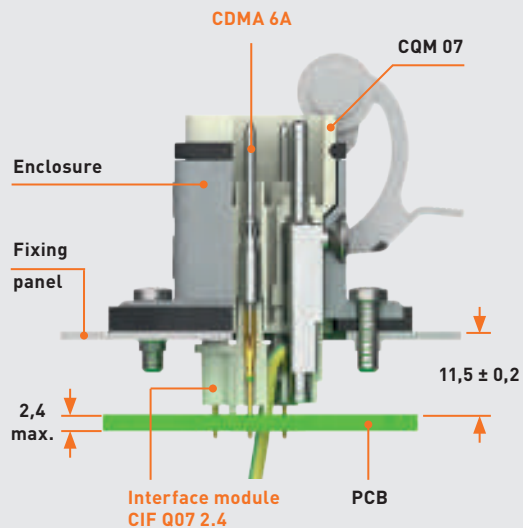
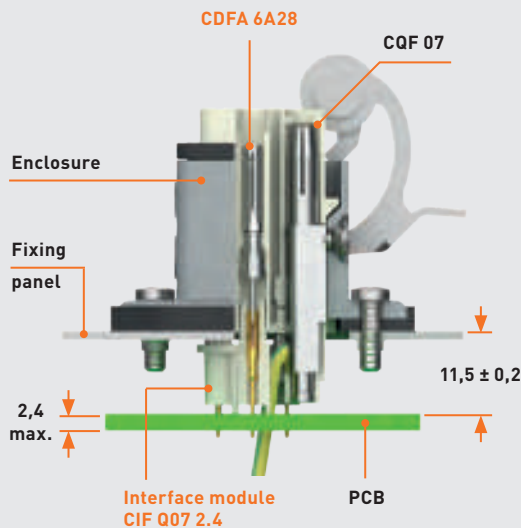
CQF 05



CQM 07



CQF 07



CIF Q05 2.4 / CIF Q07 2.4

D


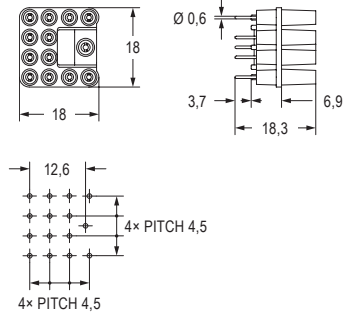

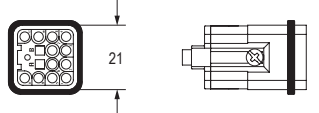

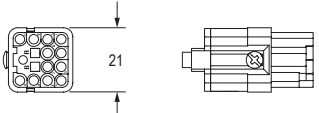

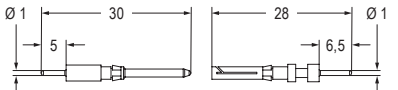

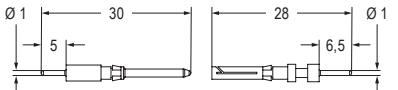
CIF Q12 2.4

7,5 A – 250 Vsize **21.21****12 poles + ⊕****Solder connection**

EN 61984 rating	7,5 A 250 V 4 kV 3
Ambient temperature limit	-40 °C ... +125 °C



CR US ECBT2.E115072 | ECBT8.E115072

Item	Description	Part No.	Dimension
	PCB interface adapter For CQ 12 CIF male and female inserts For up to 2,4 mm thick PCB	CIF Q12 2.4	
	Male special insert for male interface contacts Insert already fitted with the special PE interface contact. To fully populate the insert, 12 interface contacts are required.	CQM 12 CIF	
	Female special insert for female interface contacts Insert already fitted with the special PE interface contact. To fully populate the insert, 12 interface contacts are required.	CQF 12 CIF	
	7,5 A male interface contacts for male insert	CDMA 6A	
	7,5 A female interface contacts for female insert	CDFA 6A28	

Materials

Insert	polycarbonate (PC)
UL 94 flame rating	V-0
Colour	pebble grey, RAL 7032
Contacts	copper alloy, silver ● plated


CR Q12
 Coding pins
 Page G.3

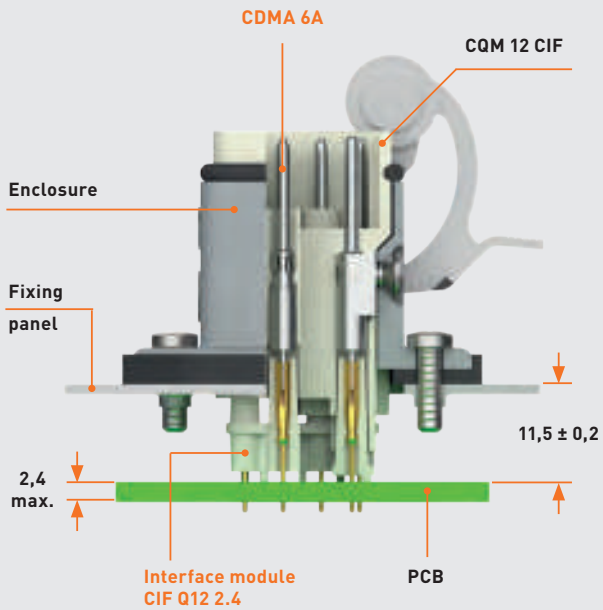
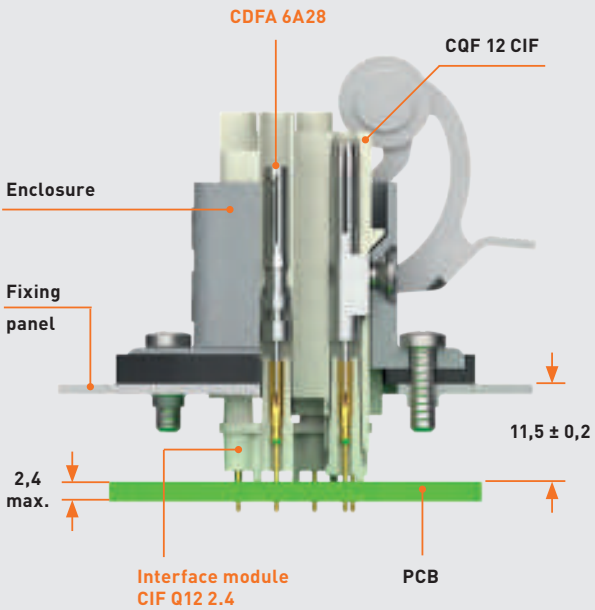
The adapter is soldered on the printed circuit on which the multipole connector (male or female) equipped with interface contacts will be inserted.



CQM 12



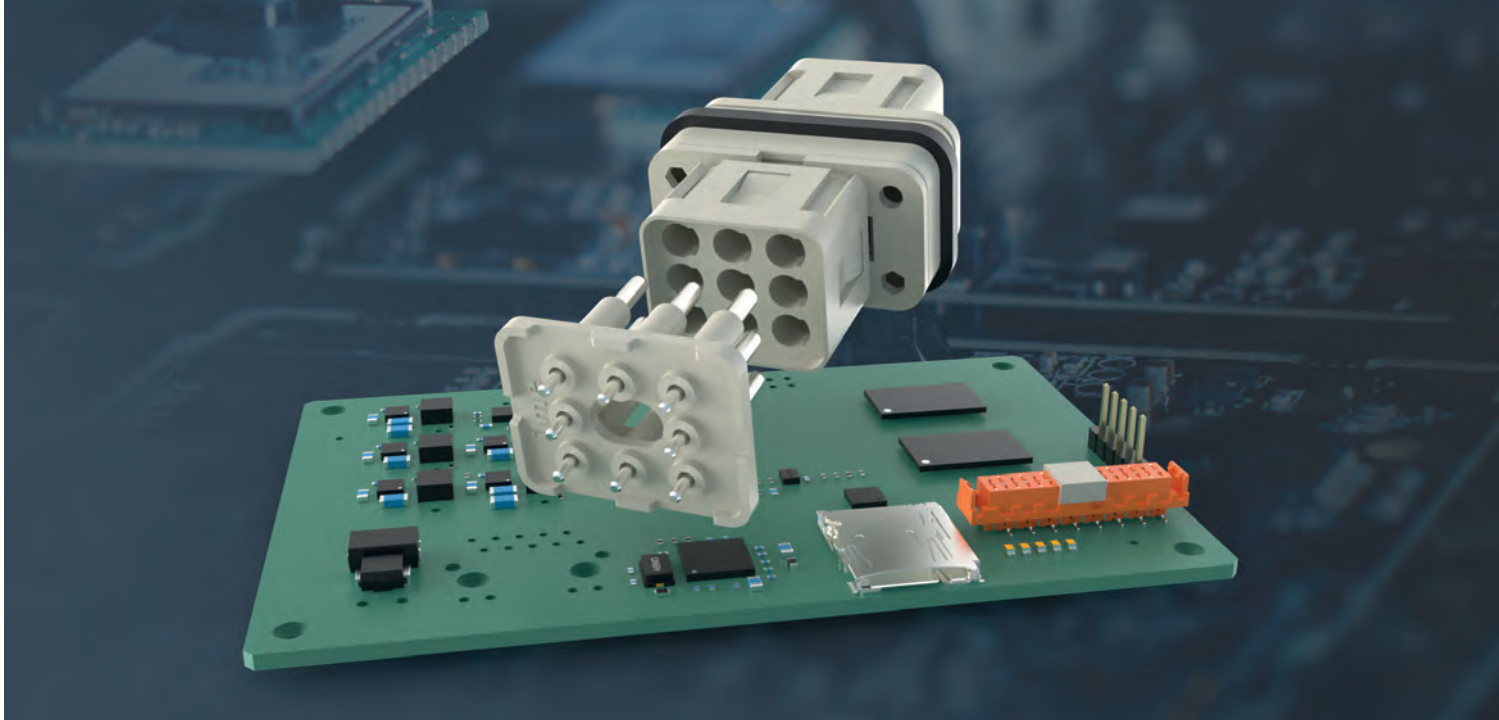
CQF 12



CIF Q12 2.4



PCB adapters for inserts



CQ series size 32.13

D

CQ series size 32.13

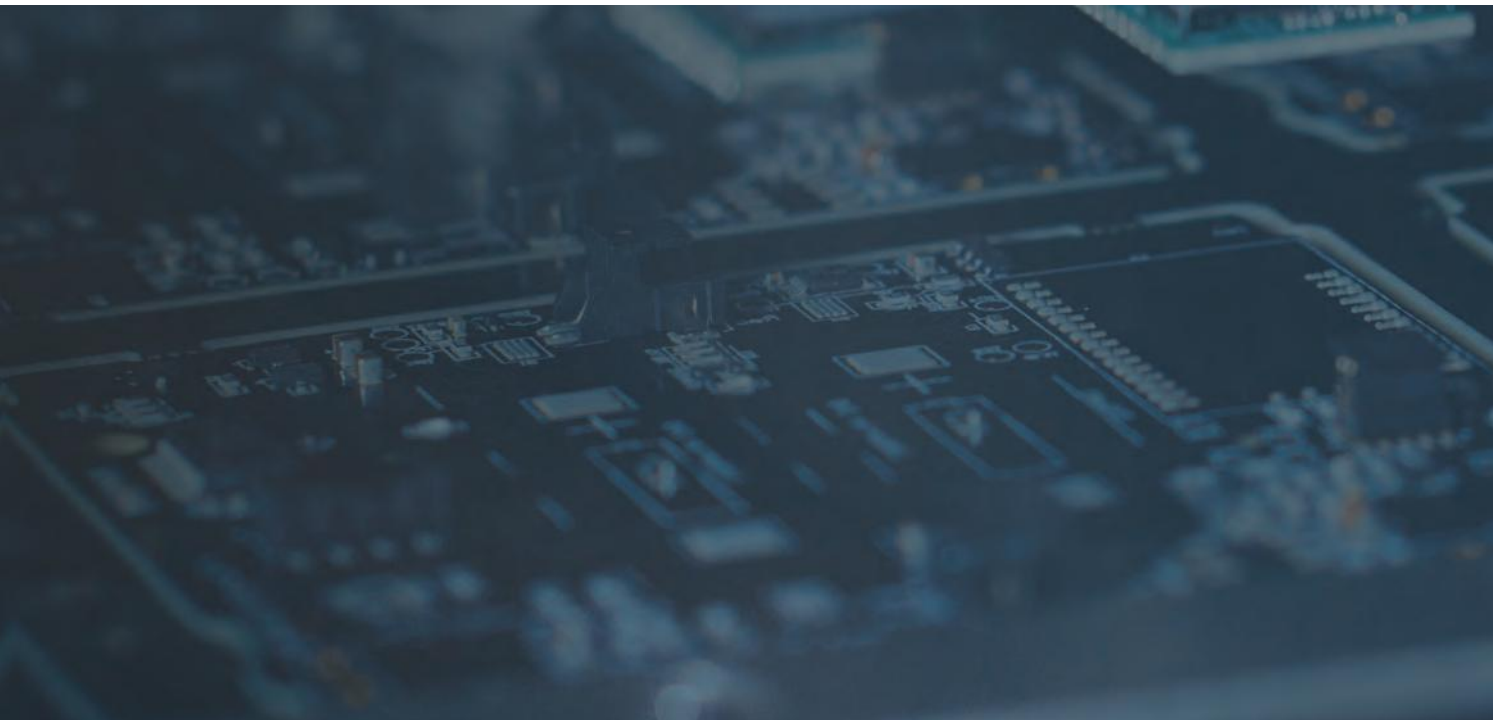
CIF Q4/2 2.4

The CIF Q4/2 2.4 PCB interface adapter is suitable for printed circuit board application by soldering to PCBs with thickness up to 2,4 mm, allowing cable to printed circuit board connection with CQ 04/2 4P + ⊕ (+ 2 auxiliary contacts) inserts.

For the connection to the PCB adapter of CQ 04/2 and CQ 04/2B inserts, it is necessary to equip these standard inserts with special interface contacts:

- > **CXFFA - 30 A** female interface contacts for CQF 04/2 and CQF 04/2B main contacts
- > **CXMFA - 30 A** male interface contacts for CQM 04/2 and CQM 04/2B main contacts
- > **CDFA 6A28 - 7,5 A** female interface contacts for CQF 04/2 and CQF 04/2B aux contacts
- > **CDMA 6A - 7,5 A** male interface contacts for CQM 04/2 and CQM 04/2B aux contacts





CIF Q08 1.6

The CIF Q08 1.6 PCB interface adapter is suitable for printed circuit board application by soldering to PCBs with thickness up to 1,6 mm, allowing cable to printed circuit board connection with CQ 08 8P + ⊕ inserts.

For the connection to the PCB adapter of CQ 08 and CQ 08E inserts, it is necessary to equip these standard inserts with special interface contacts:

- > **CCFFA - 16 A** female interface contacts for CQF 08 and CQF 08E
- > **CCMFA - 16 A** male interface contacts for CQM 08 and CQM 08E

Due to the contact pitch and the layout pattern on the PCB, a reduction of rated voltage for CQ 08 and CQ 08E insert is required from 500 V to 230/400 V.



CIF Q4/2 2.4 / CIF Q08 1.6

30 A – 400 / 690 V (7,5 A – 250 V)

16 A – 230 / 400 V

size **32.13**

4 + 2 poles + ⊕

8 poles

Solder connection

EN 61984 rating

- CIF Q4/2 2.4 30 A (4 poles) 30 A 400 / 690 V 6kV 2

- CIF Q4/2 2.4 7,5 A (2 poles) 7,5 A 250 V 4kV 2


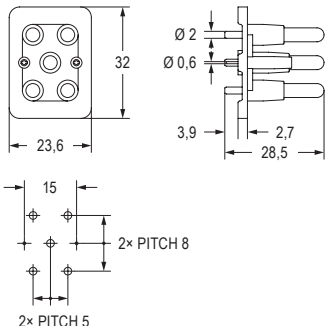

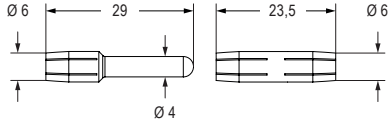


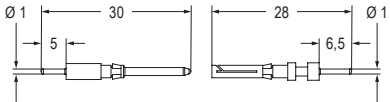


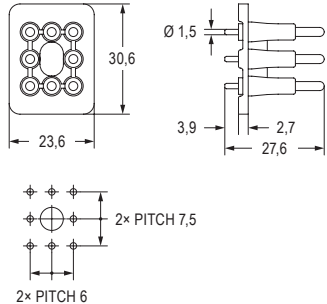

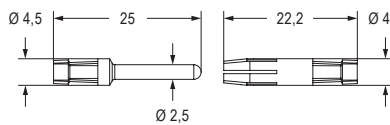

- CIF Q08 1.6 16 A 230 / 400 V 4kV 2

Contact resistance $\leq 3 \text{ m}\Omega$

Ambient temperature limit $-40 \text{ }^\circ\text{C} \dots +125 \text{ }^\circ\text{C}$



CALUS® ECBT2.E115072 | ECBT8.E115072

Item	Description	Part No.	Dimension
	PCB interface adapter For CQ 04/2 and CQ 04/2B inserts For up to 2,4 mm thick PCB	CIF Q4/2 2.4	
	30 A male interface contacts for male insert	CXMFA	
	30 A female interface contacts for female insert	CXFFA	
	7,5 A male interface contacts for male insert	CDMA 6A	
	7,5 A female interface contacts for female insert	CDFA 6A28	
	PCB interface adapter For CQ 08 and CQ 08E inserts For up to 1,6 mm thick PCB This PCB interface adapter foresees the protective earth connection (PE) of the corresponding CQ 08 and CQ 08E connector to be pass-through. For this purpose, a $\varnothing 6,4$ mm hole is foreseen in the PCB layout in correspondence of the PE contact.	CIF Q08 1.6	
	16 A male interface contacts for male insert	CMFA	
	16 A female interface contacts for female insert	CCFFA	

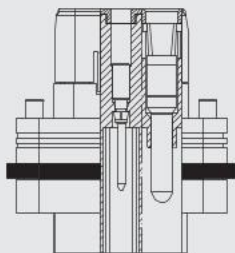
Inserts size 32.13	Poles	Pages
CIF Q4/2 2.4		
CQ 04/2E	40 A/10 A	4/2 (aux.) + ⊕ B.6
CQ 04/2	40 A/10 A	4/2 (aux.) + ⊕ B.7
CQ 04/2B	40 A/10 A	4/2 (aux.) + ⊕ B.8
CIF Q08 1.6		
CQ 08E	16 A	8 + ⊕ B.9
CQY 08E	16 A	8 + ⊕ B.10
CQ 08	16 A	8 + ⊕ B.11

Materials

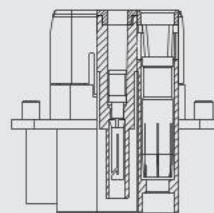
Insert	polycarbonate (PC)
UL 94 flame rating	V-0
Colour	pebble grey, RAL 7032
Contacts	copper alloy, silver plated

The adapter is soldered on the printed circuit on which the multipole connector (male or female) equipped with interface contacts will be inserted.

CQM 04/2 / CQM 04/2B



CQM 04/2 / CQM 04/2B



CQF 04/2 / CQF 04/2B

CDFA 6A28

CXFFA

Enclosure
CQ 08 I / CQS 08 I

Fixing
panel

2,4

X

X = 16 $\begin{smallmatrix} +1 \\ 0 \end{smallmatrix}$ with CQ 04/2
X = 17 $\begin{smallmatrix} +0.5 \\ 0 \end{smallmatrix}$ with CQ 04/2B

X = 16 $\begin{smallmatrix} +2 \\ 0 \end{smallmatrix}$ with CQ 04/2
X = 17 $\begin{smallmatrix} +1 \\ 0 \end{smallmatrix}$ with CQ 04/2B

PCB

Interface
module

CIF Q4/2 2.4

CQF 04/2 / CQF 04/2B

CDMA 6A28

CXMFA

Enclosure
CQ 08 I / CQS 08 I

Fixing
panel

2,4

X

X = 16 $\begin{smallmatrix} +1 \\ 0 \end{smallmatrix}$ with CQ 04/2
X = 17 $\begin{smallmatrix} +0.5 \\ 0 \end{smallmatrix}$ with CQ 04/2B

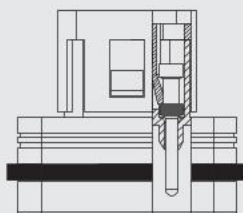
X = 16 $\begin{smallmatrix} +2 \\ 0 \end{smallmatrix}$ with CQ 04/2
X = 17 $\begin{smallmatrix} +1 \\ 0 \end{smallmatrix}$ with CQ 04/2B

PCB

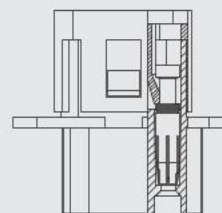
Interface
module

CIF Q4/2 2.4

CQM 08 / CQM 08E



CQF 08 / CQF 08E



CQF 08 / CQF 08E

CCFFA

Enclosure
CQ 08 I / CQS 08 I for CQ 08
CQA 08 I for CQ 08E

Fixing
panel

1,6

16,5 $\begin{smallmatrix} +2 \\ 0 \end{smallmatrix}$

X

PCB

Interface
module

CIF Q08 1.6

CQM 08 / CQM 08E

Enclosure
CQ 08 I / CQS 08 I for CQ 08
CQA 08 I for CQ 08E

Fixing
panel

1,6

16,5 $\begin{smallmatrix} +2 \\ 0 \end{smallmatrix}$

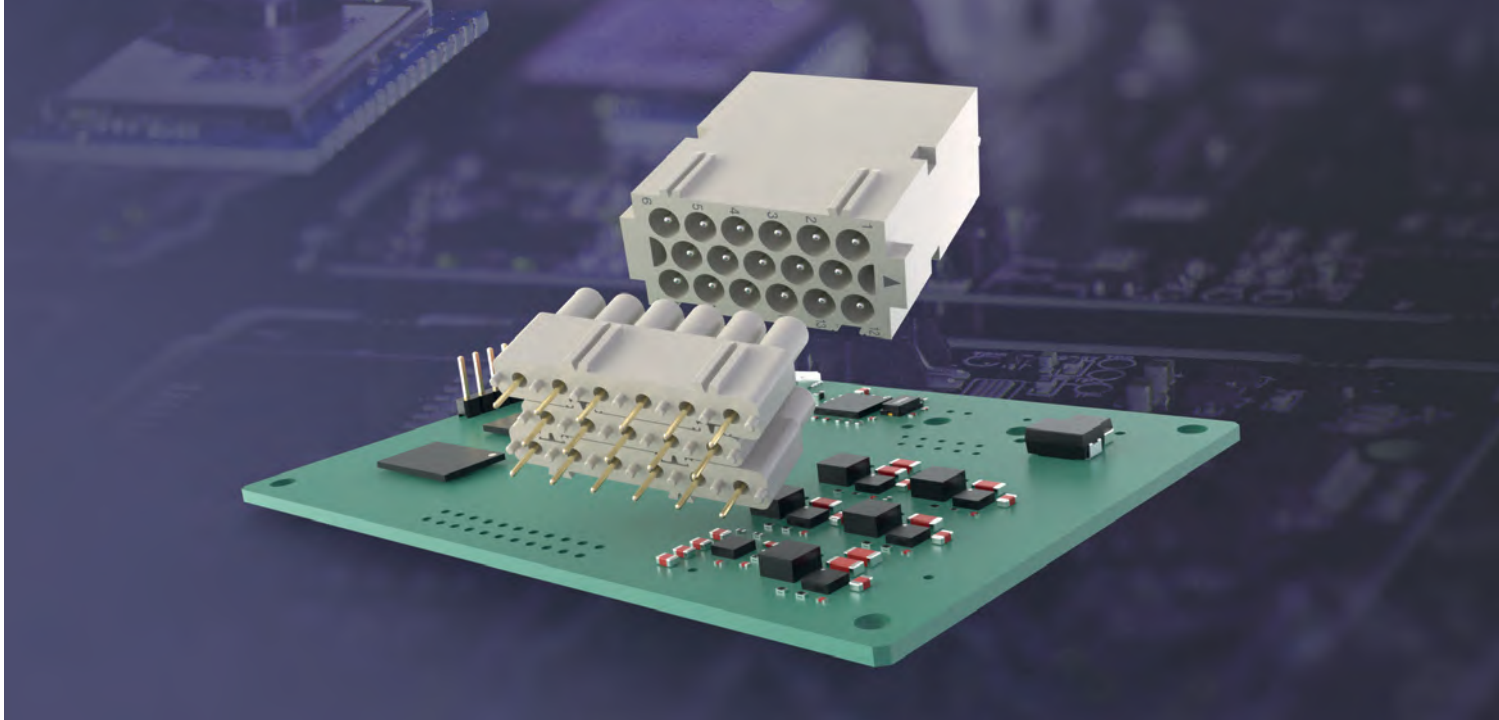
X

PCB

Interface
module

CIF Q08 1.6

PCB adapters for inserts



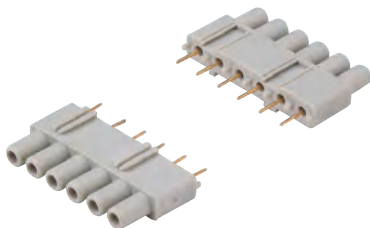
CDD, CX and MIXO series

D

CDD, CX and MIXO series

CIF 2.4

6-pole PCB adapter, suitable in multiple units to provide PCB interface for series CDD inserts size 24 (4 units) 42 (7 units), 72 (12 units) and 108 (18 units), the 24-pole section of combined connector inserts CX 8/24 (3 units) or the 36-pole section of CX 6/36 (6 units), and MIXO CX 12 DF/ DM modules (2 units).

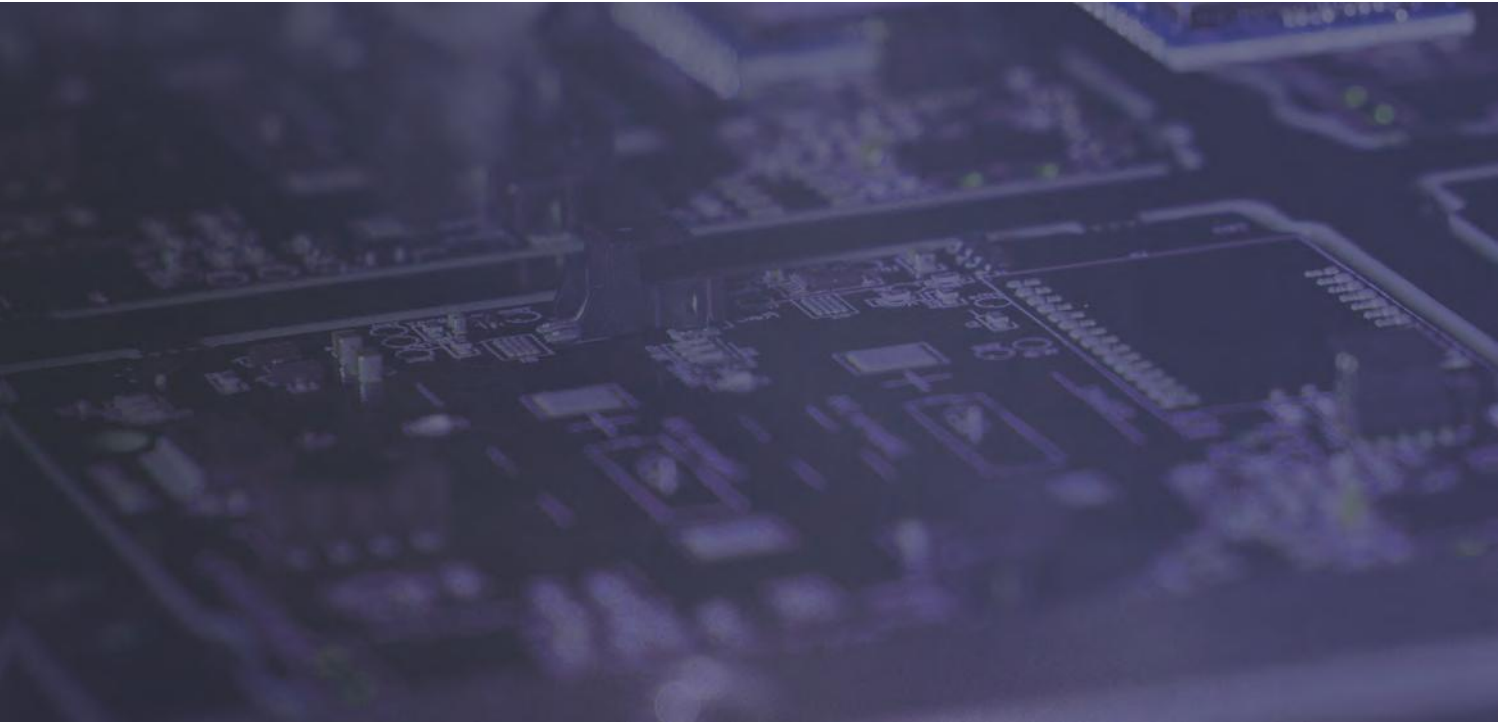
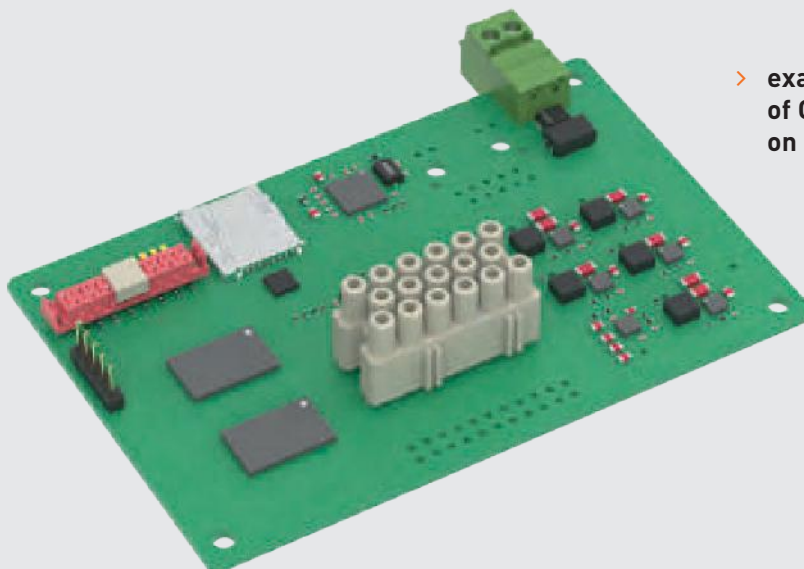


CIF 5 2.4

5-pole interface adapter that once mounted in-between 2x CIF 2.4, 6-pole interface adapter connectors, forms a 17-pole PCB interface “block” equipped with female gold-plated contacts with rear post for soldering to the PCB.

Either so grouped, or conveniently purchased in the dedicated complete set CIF X17 2.4, it serves as interface for either a male or a female high-density module CX 17 DF or CX 17 DM of series MIXO, each equipped with corresponding interface contacts CDFA 6A or CDMA 6A32 (silver plated) with rear post \varnothing 1 mm suitable for mating with the CIF adapter female contacts



**FOCUS****Application of interface adapter**

- > example of use of CIF X17 2.4 on a PCB

CIF 2.4 / CIF 5 2.4 / CIF X17 2.4


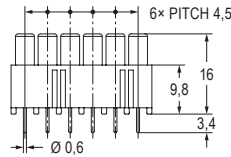


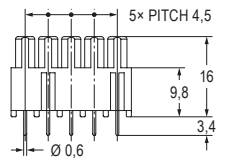

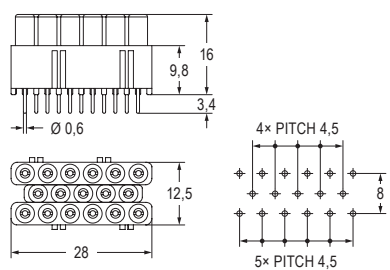



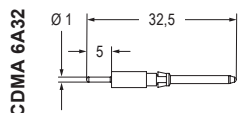

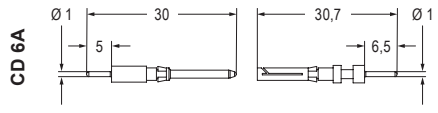



7,5 A – 160 V

Solder connection

EN 61984 rating	7,5 A 160 V 2,5 kV 3
Rated voltage (UL / CSA)	160 V
Insulation resistance	≥ 10 GΩ
Ambient temperature limit	-40 °C ... +125 °C



CALUS® ECBT2.E115072 | ECBT8.E115072

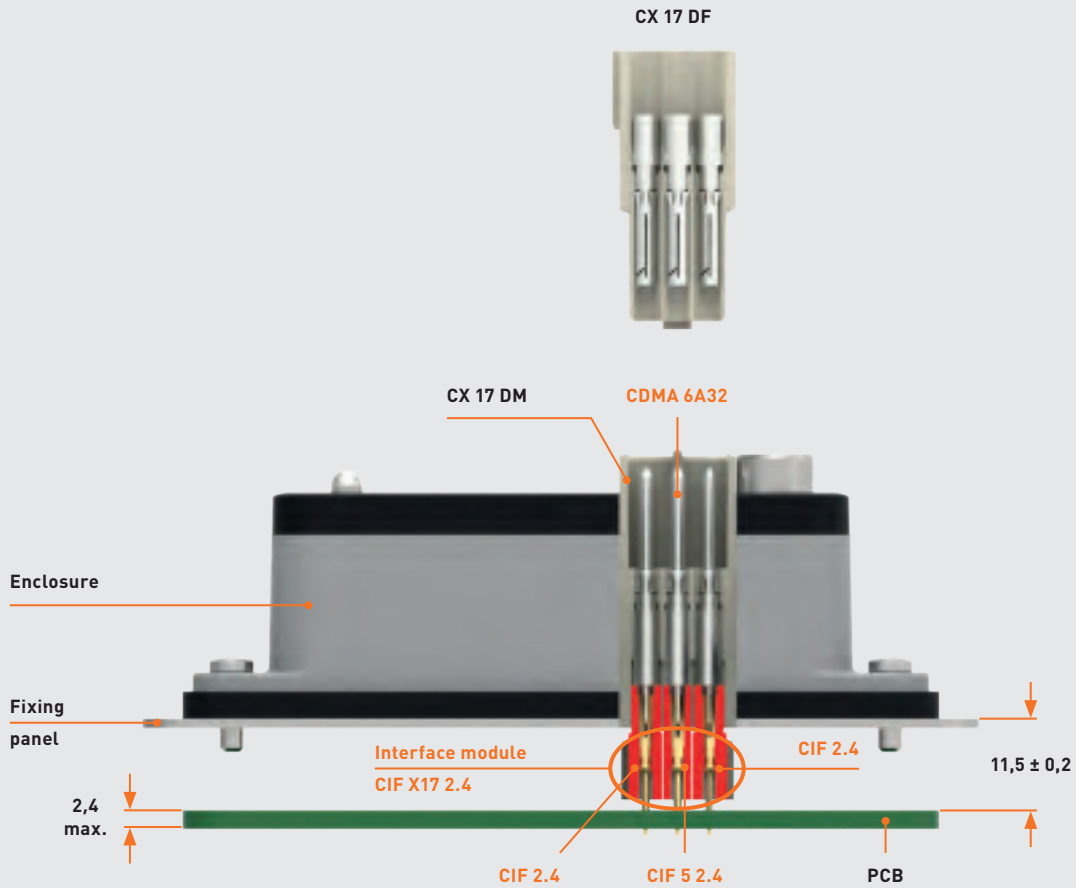
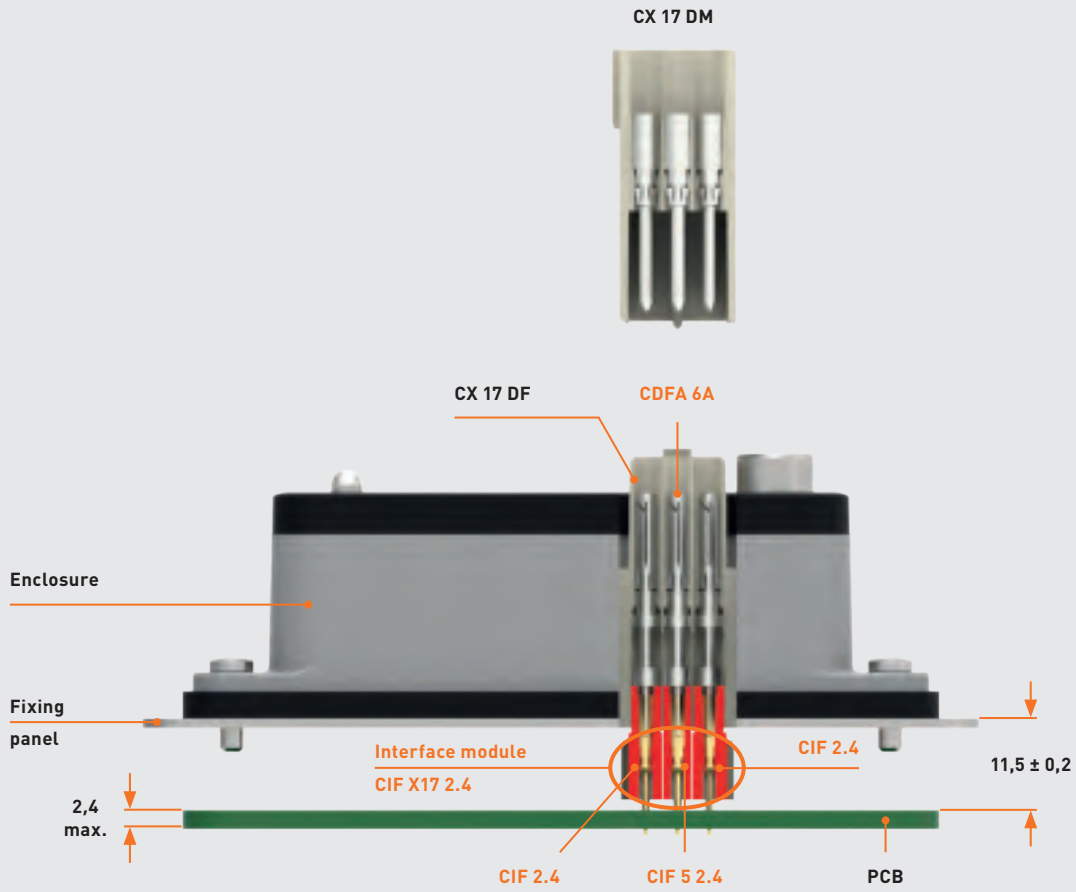
Item	Description	Part No.	Dimension
	PCB interface adapter with 6 gold contacts; for up to 2,4 mm thick PCB	CIF 2.4	
	PCB interface adapter with 6 silver contacts; for up to 2,4 mm thick PCB	CIF 2.4 A	
	PCB interface adapter, 5 poles alone, to be combined with 2× CIF 2.4 For up to 2,4 mm thick PCB	CIF 5 2.4	
	PCB interface adapter, complete set with 17 contacts For up to 2,4 mm thick PCB	CIF X17 2.4	
	CIF 2.4		
	CIF 5 2.4		
	6 A male interface contacts for male insert; to be used with CIF X17 2.4 interface adapters and CX 17 DM male MIXO module	CDMA 6A32	
	6 A male interface silver plated contacts for male insert; to be used with CIF 2.4 A interface adapters	CDMA 6A	
	6 A female interface silver plated contacts for male insert; to be used with CIF 2.4 A interface adapters	CDFA 6A	
	6 A male interface gold plated contacts for male insert; to be used with CIF 2.4 interface adapters	CDMD 6A	
	6 A female interface gold plated contacts for male insert; to be used with CIF 2.4 interface adapters	CDFD 6A	

Inserts	Poles	Pages
CIF 2.4/CIF 5 2.4		
CDD	10 A	24 to 108 + ⊕ B.94-97
CX 6/36	40 A/10 A	6/36 (aux.) + ⊕ B.169
CX 8/24	16 A/10 A	8/24 (aux.) + ⊕ B.170-171
CX 12 D	10 A	12 C.46
CIF X17 2.4		
CX 17 D	10 A	17 C.48

Materials

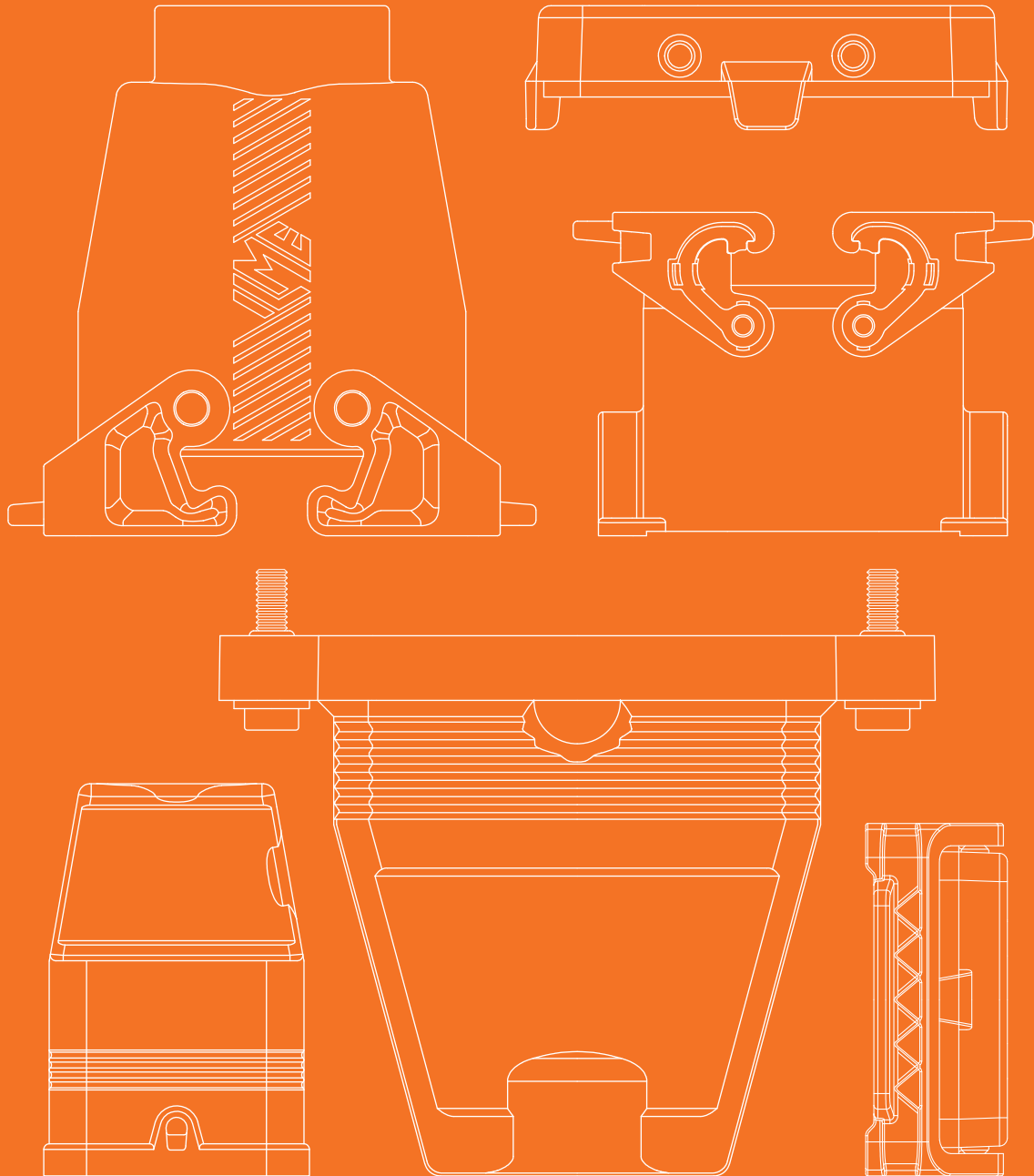
Insert	polycarbonate (PC)
UL 94 flame rating	V-0
Colour	pebble grey, RAL 7032
Contacts	copper alloy, silver ● and gold ● plated

The adapter is soldered on the printed circuit on which the multipole connector (male or female) equipped with interface contacts will be inserted.



CIF 2.4 / CIF 5 2.4 / CIF X17 2.4

D

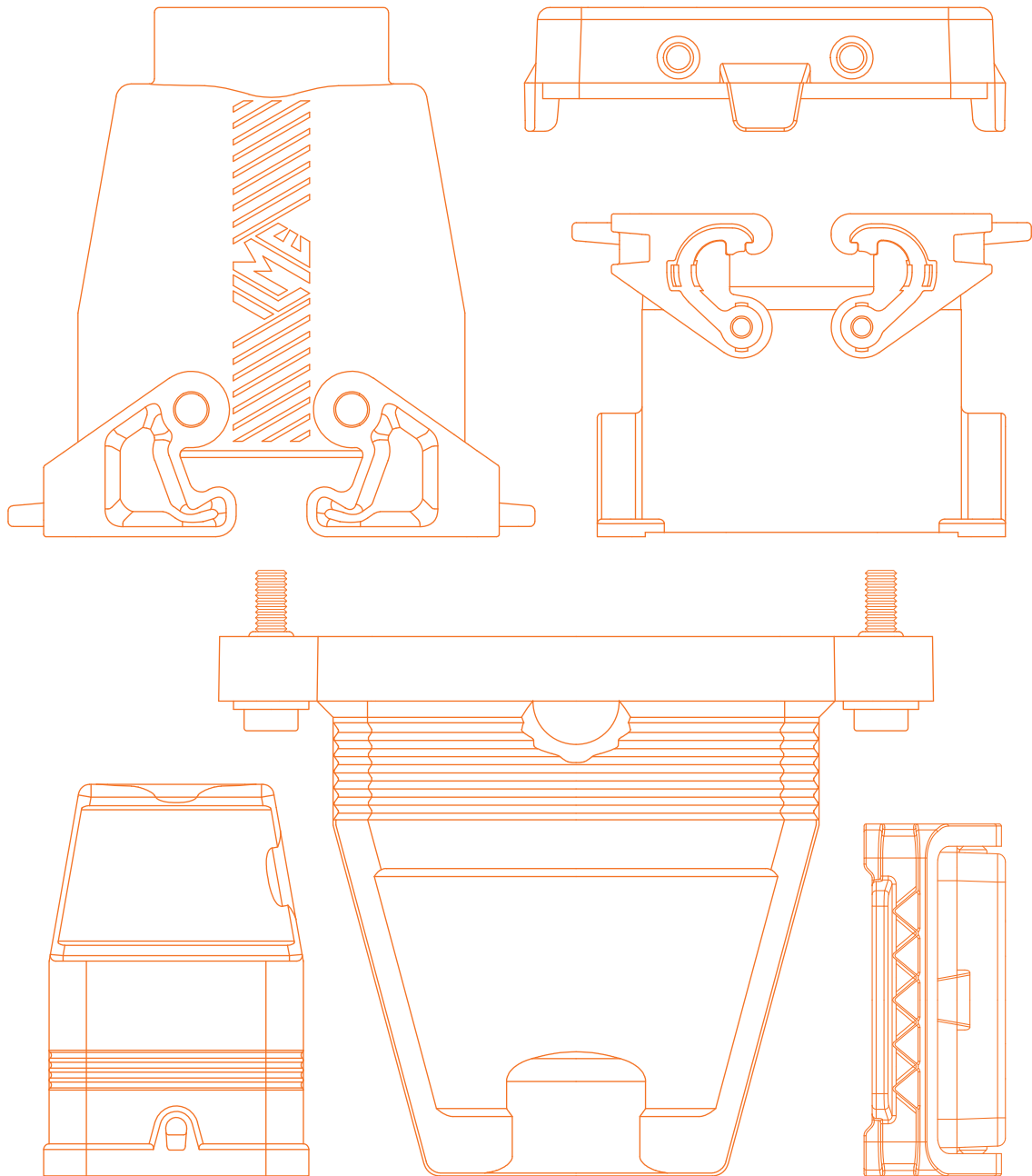


GENERAL CATALOGUE

Enclosures

Contents

	<p>Size 32.13 E.4</p> <p>Compact enclosures</p> <ul style="list-style-type: none"> - CQ / MQ Thermoplastic series E.6-7 - CQ / MQ Thermoplastic series – EMC version E.8-9 - CQA / MQA Metallic series – EMC version E.10
	<p>Size 49.16, 66.16 and 66.40 E.12</p> <p>Slim enclosures</p> <ul style="list-style-type: none"> - Slim enclosures with IL-BRID lever E.14-17 - Slim enclosures with JEI®-P lever E.18-19 - Slim enclosures with C-TYPE lever E.20-25 - Slim enclosures with Rigid lever – IP67 E.26-27 - Slim enclosures – W-TYPE series E.28-33 - Slim enclosures – E-Xtreme® E.34-39 - Slim enclosures – EMC series E.40-43
	<p>Size 44.27, 54.27, 77.27, 104.27, 77.62 and 104.62 E.46</p> <p>C-TYPE</p> <p>C-TYPE series E.48-85</p>
	<p>IL-BRID E.88</p> <p>IL-BRID series E.90-107</p>
	<p>JEI®-P E.110</p> <p>JEI®-P series E.112-119</p>
	<p>V-TYPE E.122</p> <ul style="list-style-type: none"> - V-TYPE series – IP67 version E.124-127 - V-TYPE series – IP65 / IP66 version E.128-135
	<p>IP68 E.138</p> <p>IP68 high protection series E.142-149</p>
	<p>W-TYPE E.152</p> <ul style="list-style-type: none"> - W-TYPE series – V-TYPE lever version E.154-161 - W-TYPE series – C-TYPE lever version E.162-169



GENERAL CATALOGUE

Enclosures

Contents

	<p>Size 44.27, 54.27, 77.27, 104.27, 77.62 and 104.62</p> <p>E-Xtreme®</p> <ul style="list-style-type: none"> - E-Xtreme® – V-TYPE lever version E.174-181 - E-Xtreme® – C-TYPE lever version E.182-193 - E-Xtreme® – IP68 high protection version E.194-197 	<i>E.172</i>
	<p>EMC</p> <ul style="list-style-type: none"> - EMC series – IL-BRID lever version E.208-215 - EMC series – C-TYPE lever version E.216-219 	<i>E.200</i>
	<p>T-TYPE and T-TYPE/W</p> <p>T-TYPE series – Insulating E.226-236</p>	<i>E.222</i>
	<p>T-TYPE/H and T-TYPE/C</p> <p>T-TYPE Hygienic series – Food and Beverage E.244-249</p>	<i>E.240</i>
	<p>CENTRAL LEVER</p> <p>CENTRAL LEVER series E.254-261</p>	<i>E.252</i>
	<p>BIG</p> <p>BIG series – Multiple cable entries E.268-279</p>	<i>E.264</i>
	<p>COB</p> <p>COB series – System for switch cabinet E.286-292</p>	<i>E.282</i>
	<p>LS-TYPE</p> <p>LS-TYPE series – Light and Sound E.296-303</p>	<i>E.294</i>



Enclosures size 32.13 for standard and EMC applications



Thermoplastic size 32.13 enclosures

The thermoplastic CQ/MQ series enclosures and the equivalent metal CQA/MQA versions offer a compact and easy-to-assemble solution for general use or specific applications.

Once completed and fitted with a suitably rated cable gland or conduit fitting, they ensure an IP66 / IP67 / IP69 degree of protection according to IEC/EN 60529 for outdoor or indoor environments.

Metal CQA / MQA 08 size 32.13 enclosures

The metallic enclosures CQA/MQA size 32.13 have been developed with utmost ease of assembly and simplicity.

These zinc alloy, zinc-plated die-cast enclosures are particularly suitable for demanding EMC applications, ensuring the necessary shielding from electromagnetic interference that the 32.13 connector inserts typically require in pulse width modulation (PWM) drives (inverters) for electric motors' speed or torque motion control.

Being metallic, the CQA/MQA metal enclosures require proper bonding to protective earth (PE) for safety reasons and must be paired with the relevant CQ inserts equipped with PE plate (CQ 04/2E, CQ 08E and CQY 08E).



Watch our clip

SUM-UP

CQ – MQ series

- > Thermoplastic material, jet black RAL 9005.
- > Single-block locking lever in self-extinguishing thermoplastic material.
- > Gaskets in anti-aging, oil-resistant, grease-resistant and fuel-resistant NBR vinyl nitrile elastomer.

CQS – MQS series (EMC)

- > Made in self-extinguishing thermoplastic material, metallized.
- > Single-block locking lever in self-extinguishing thermoplastic material.
- > EMC conductive sealing gaskets on the housing versions; CR 08 EMC conductive gasket to replace the standard gasket provided on the male insert.

CQA – MQA series (EMC)

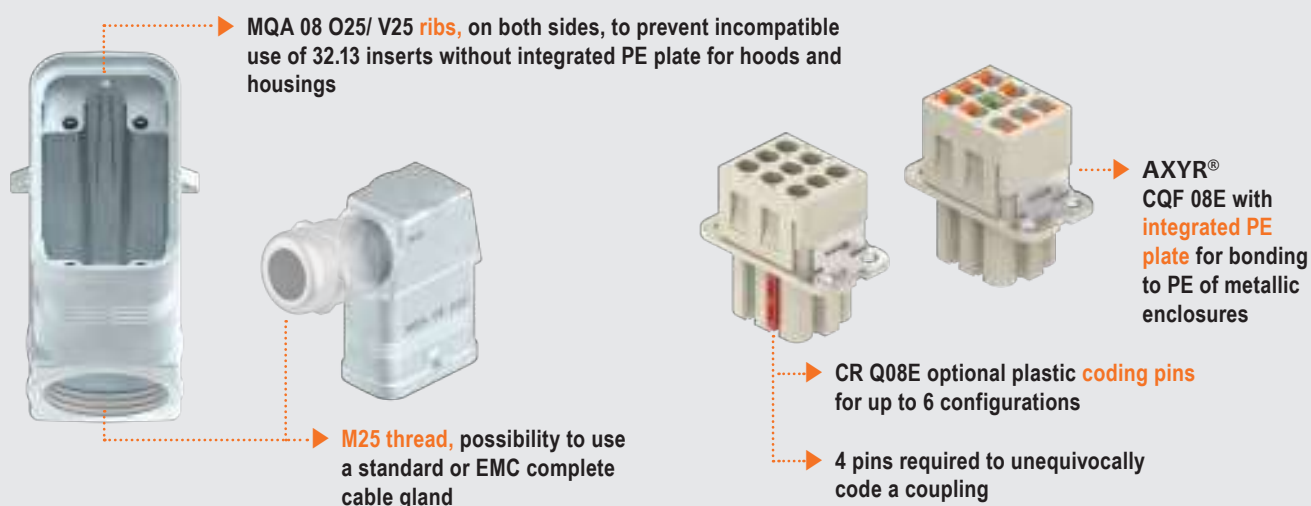
- > Made in metal, zinc-alloy die cast, zinc-plated.
- > Single-block stainless steel locking lever.
- > O-Ring gaskets in anti-aging, oil-resistant, grease-resistant and fuel-resistant NBR vinyl nitrile elastomer.
- > Optional CR 08 EMC gasket to replace the standard gasket provided on the male inserts, ideal for EMC applications.
- > Compatible with standard and EMC complete cable glands up to M25.

✔ Markings and Approvals

- CE and UKA markings, EAC not applicable
- UL certified for USA and Canada for Type 12, 4 and 4X degrees of protection (enclosure type ratings, equivalent to NEMA rating)
- IP66 / IP67 / IP69 degree of protection
- RoHS: compliant

FOCUS

Metal enclosures' technology



CQ / MQ Thermoplastic series

Housings and hoods – 1 lever

size **32.13**

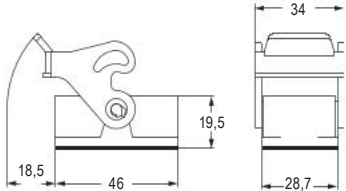

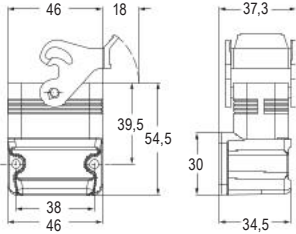

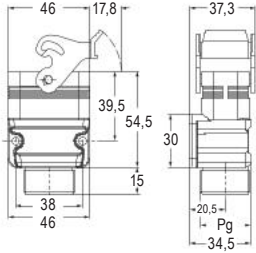

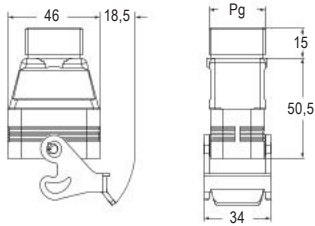
Heavy-Duty Applications 

CE UK CA

CEC DNV VERITAS

EN 60529	IP66 / IP67 / IP69
UL 50 / UL 50E	Type 12 / 4 / 4X
Ambient temperature limits	-40 °C ... +125 °C
Mechanical life (cycles)	≥ 500

CAIUS ECBT2.E115072 | ECBT8.E115072

Item	Description	Part No.	Entry	Dimension
	Bulkhead mounting housings, 1 lever	CQ 08 I		
	Angled bulkhead mounting housings, 1 lever	CQ 08 IA		
	Angled bulkhead mounting housings, 1 lever, with cable entry Pg male thread on the outside of the housing	CQ 08 IAP	Pg 21	
	Hoods, 1 lever, top entry Pg male thread on the outside of the hood	CQ 08 VG	Pg 21	

CQ / MQ

E

Inserts size 32.13	Poles	Pages
CQ	40 A/10 A	4/2 (aux.) + ⊕
CQ \ CQY	16 A	8 + ⊕
CQ	10 A	17 + ⊕

Accessories:



CRQ 16, CRQ 21
Semi cable gland with gasket
for CQ enclosures
Page [E.9](#)

CQ / MQ Thermoplastic series

size **32.13**

Hoods and covers – 2 pegs

Heavy-Duty Applications

EN 60529	IP66 / IP67 / IP69
UL 50 / UL 50E	Type 12 / 4 / 4X
Ambient temperature limits	-40 °C ... +125 °C
Mechanical life (cycles)	≥ 500


CAIUS ECBT2.E115072 | ECBT8.E115072

Item	Description	Part No.	Entry	Dimension
	Hoods, 2 pegs, side entry Pg male thread on the outside of the hood	CQ 08 VA	Pg 16	
	Hoods, 2 pegs, top entry Pg male thread on the outside of the hood	CQ 08 V	Pg 21	
	Hoods, 2 pegs, side and top entries	MQ 08 VQ225	M25 × 2	
	Covers, 2 pegs For enclosures with 1 lever	For female inserts CQ 08 C For male inserts CQ 08 CA		

Inserts size 32.13	Poles	Pages
CQ	40 A/10 A	4/2 (aux.) + ⊕
CQ \ CQY	16 A	8 + ⊕
CQ	10 A	17 + ⊕

Accessories:

CRQ 16, CRQ 21
 Semi cable gland with gasket
 for CQ enclosures
 Page E.9

CQ / MQ Thermoplastic series – EMC version

size **32.13**

Housings and hoods – 1 lever

Specialized Applications




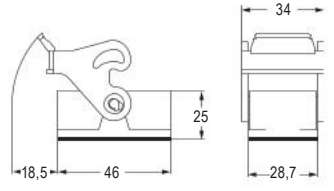

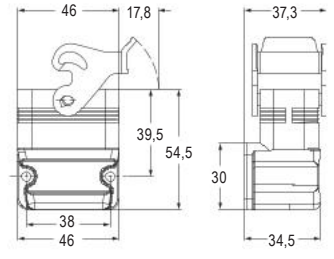

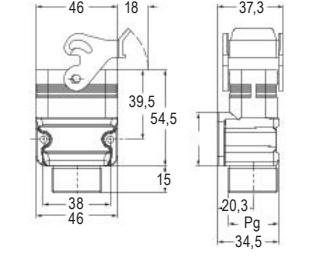

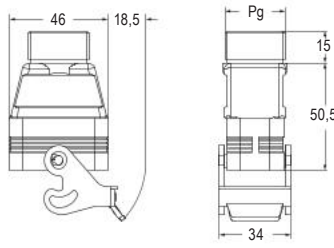
Heavy-Duty Applications



EN 60529	IP66 / IP67
UL 50 / UL 50E	Type 12
Ambient temperature limits	-40 °C ... +125 °C
Mechanical life (cycles)	≥ 500



CEC DNV VERITAS
CAIUS ECBT2.E115072 | ECBT8.E115072

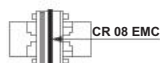
Item	Description	Part No.	Entry	Dimension
	Bulkhead mounting housings, 1 lever	CQS 08 I		
	Angled bulkhead mounting housings, 1 lever	CQS 08 IA		
	Angled bulkhead mounting housings, 1 lever, with cable entry Pg male thread on the outside of the housing	CQS 08 IAP	Pg 21	
	Hoods, 1 lever, top entry Pg male thread on the outside of the hood	CQS 08 VG	Pg 21	

CQ / MQ

E

Inserts size 32.13		Poles	Pages
CQ	40 A/10 A	4/2 (aux.) + ⊕	3.6-3
CQ \ CQY	16 A	8 + ⊕	3.9-11
CQ	10 A	17 + ⊕	3.12

Note: When using an EMC "CQS 08" series enclosure with a male insert, replace the standard gasket provided on the male insert with a conductive gasket CR 08 EMC, to be ordered separately.



CQ / MQ Thermoplastic series – EMC version

size **32.13**

Hoods – 2 pegs

Specialized
ApplicationsHeavy-Duty
Applications

EN 60529	IP66 / IP67
UL 50 / UL 50E	Type 12
Ambient temperature limits	-40 °C ... +125 °C
Mechanical life (cycles)	≥ 500



ECBT2.E115072 | ECBT8.E115072

Item	Description	Part No.	Entry	Dimension
	Hoods, 2 pegs, side or top entry	Side Entry	Top Entry	
	Pg male thread on the outside of the hood	CQS 08 VA	CQS 08 V	

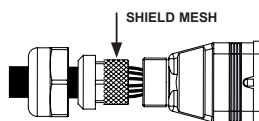
	Hoods, 2 pegs, side and top entries	MQS 08 VO225	M25 × 2	
--	-------------------------------------	---------------------	---------	--

	Conductive gaskets for CQM male inserts	CR 08 EMC		
--	---	---------------------------	--	--

	Thermoplastic resin cable glands	For CQS 08 VA	
	for cable diameters: 10 - 14,5 mm 4 - 7 mm 7 - 14,5 mm	CRQ 16 CRQ 16-1 CRQ 16-2	
	for cable diameters: 14 - 18 mm 7 - 18 mm 10 - 18 mm 17,5 - 20,5 mm	For CQS 08 V, VG and IAP	
		CRQ 21	
		CRQ 21-1	
		CRQ 21-2 CRQ 21-3	

ASSEMBLY INSTRUCTIONS

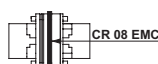
Place the cable shield mesh between the CRQ cable gland gasket and the seat of the gasket itself.



Part No.	A	B	C	D	E	Ø	Ch
CRQ 16, 16-1, 16-2	15,5	21,5	20,3	13,5	6,8	21	27
CRQ 21	18,2	27,5	25	15,5	9	26,5	33
CRQ 21-1	18,2	27,5	25	16	9	26,5	33
CRQ 21-2	18,2	27,5	25	16	9	26,5	33
CRQ 21-3	22	22	9	–	9	26,5	33

Inserts size 32.13	Poles	Pages
CQ	40 A/10 A	B.6-8
CQ \ CQY	16 A	B.9-11
CQ	10 A	B.12

Note: When using an EMC "CQS 08" series enclosure with a male insert, replace the standard gasket provided on the male insert with a conductive gasket CR 08 EMC, to be ordered separately.



CQA / MQA Metallic series – EMC version

size **32.13**

Housings and hoods – 1 lever – 2 pegs

Specialized Applications




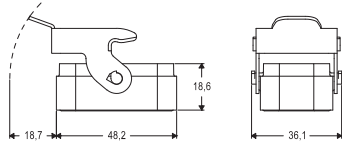

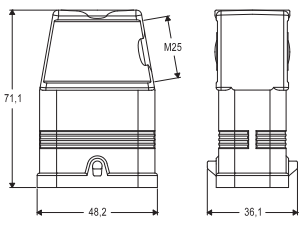

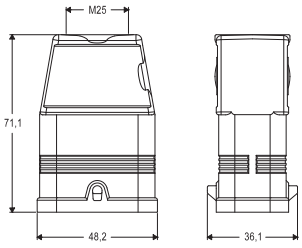

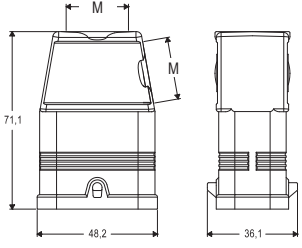
Heavy-Duty Applications



EN 60529	IP66 / IP67 / IP69
UL 50 / UL 50E	Type 12 / 4 / 4X
Ambient temperature limits	-40 °C ... +125 °C
Mechanical life (cycles)	≥ 500



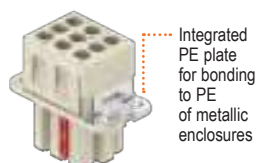
CAUS® ECBT2.E115072 | ECBT8.E115072

Item	Description	Part No.	Entry	Dimension
	Bulkhead mounting housings, 1 lever	CQA 08 I		
	Hoods, 2 pegs, side entry To be used only with a complete cable gland	MQA 08 Q25	M25	
	Hoods, 2 pegs, top entry To be used only with a complete cable gland	MQA 08 V25	M25	
	Hoods, 2 pegs, side and top entries To be used only with a complete cable gland on one entry and a plug on the other entry	MQA 08 VO220 MQA 08 VO225	M20 × 2 M25 × 2	

CQ / MQ
E

Inserts size 32.13	Poles	Pages
CQ	40 A/10 A	B.6-8
CQ \ CQY	16 A	B.9-11

Note: Enclosures coded for use with 32.13 PE inserts only.



Panel cut-out drawings

For size 32.13 series bulkhead mounting housings

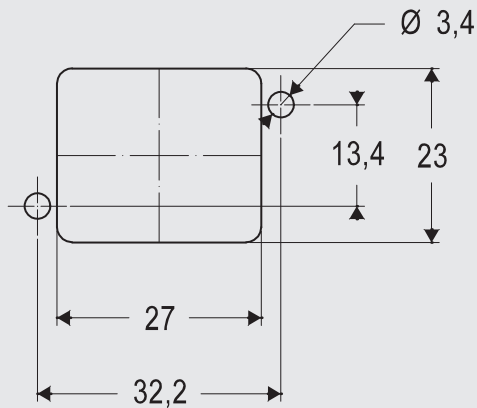
To guarantee the declared IP degree of protection of the housings reported in this catalogue, according to EN IEC 60529 or to the relevant Type rating per ANSI/UL 50 and 50E (for those products bearing approval to those ratings), the surface of the mounting panel must meet the following requirements (definitions are provided in ISO 4287 standard):

Waviness $W_t \leq 0,2$ mm over a distance of 200 mm
(measured on the panel without load)

Roughness $R_a \leq 16$ μm

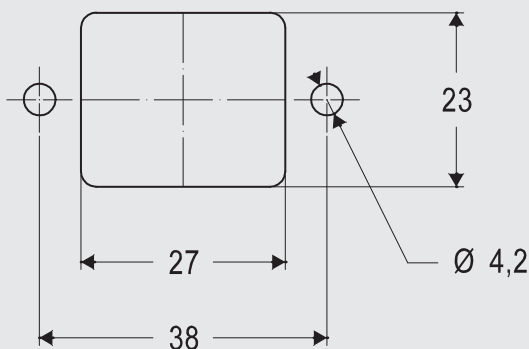
Scale 1:1

Size 32.13 Bulkhead mounting housings



Required screws: 2
Screws size: M3
Recommended torque:
 0,8 – 1,0 Nm / 7.1 – 8.9 lb.in

Size 32.13 Angled bulkhead mounting housings



Required screws: 2
Screws size: M4
Recommended torque:
 0,8 – 1,0 Nm / 7.1 – 8.9 lb.in

Notes: The values of tightening torque indicated above are just recommended values, that must be related – by the designer of the final application – to the resistance class of the screws (not included), with the assumption that the mounting panel is sufficiently rigid (stiff). If the deflection of the panel, under the effect of tightening the screws, is greater than 0,7 mm over a distance of 100 mm, it is necessary to use the counter-flanges mentioned in our catalogue or the special flange gaskets available upon request (please contact our Sales Department).



Slim enclosures

size 49.16, 66.16 and 66.40



Slim-size enclosures

Slim-size enclosures offer a practical compromise between compactness and connection density for heavy-duty industrial applications.

The product range is identified by its distinctive sizes: 49.16 and 66.16 for a single insert layout and 66.40 for a double insert layout.

Slim-size enclosures have an IL-BRID locking device that combines the thermoplastic material's smoothness with the stainless steel's sturdiness.

Available for aggressive environments in W-TYPE, E-Xtreme® or EMC versions.



Simplex
self
closing
cover
available
version

❖ Markings and Approvals

- CE and UK markings, EAC not applicable
- UL certified for USA and Canada for Type 12, 4 and 4X degrees of protection (enclosure type ratings, equivalent to NEMA rating)
- IP65 / IP66 / IP67 / IP69 degree of protection
- RoHS: compliant

SUM-UP

Heavy-Duty Applications

- > Made of die cast aluminium alloy with epoxy-polyester powder coating, grey RAL 7040.
- > Single-block locking lever in IL-BRID, Rigid, JEI®-P and C-TYPE version.
- > Gaskets in anti-aging, oil-resistant, grease-resistant and fuel-resistant NBR vinyl nitrile elastomer.

Aggressive Environments

- > Made of die cast aluminium alloy.
- > W-TYPE version with chromate conversion coating, RoHS 2 conform and epoxy-polyester powder coating, black RAL 9001.
- > E-Xtreme® version with patented treatment under the coating, dark grey RAL 7016, for maximum resistance against corrosion.
- > Gaskets in anti-aging FKM fluoroelastomer

Specialized Applications (EMC)

- > Made of die cast aluminium alloy.
- > Single-block stainless steel rigid locking lever.
- > Conductive gaskets in EMI/RFI rubber material, ideal for EMC applications.

FOCUS

Levers and technology



IL-BRID

Combined performance

Through its original design, the IL-BRID locking lever for slim housings combines the flexibility of thermoplastic material with the resilience of stainless steel, reducing the wear on the hood pegs and improving the overall performance of the connection.



JEI®-P

Thermoplastic locking lever

Single-block locking lever in self-extinguishing thermoplastic material with enhanced ergonomics and reduced dimension, ideal for basic requirements and less demanding environments.



CZ7 – Rigid lever


Rigid locking lever in stainless steel

In case of harsh installation conditions and to achieve IP66/IP67/IP69 degrees of protection, the rigid lever is available for slim enclosures and is equipped as standard in W-TYPE and EMC slim housings.

Slim enclosures with IL-BRID lever

size **49.16**

Housings, hoods and covers – 1 lever


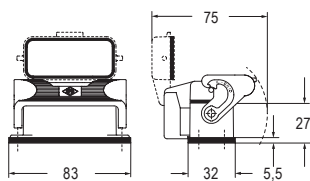

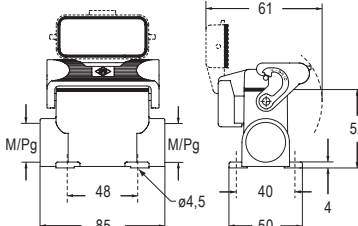

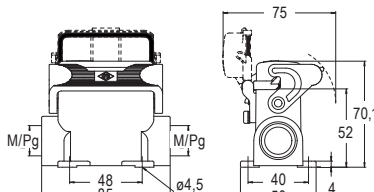

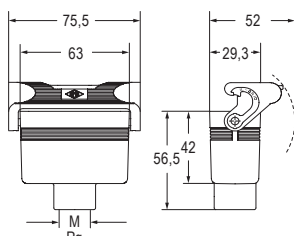


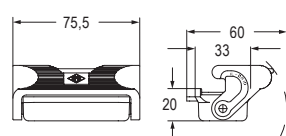
Heavy-Duty Applications 

CE UK CA

EN 60529	IP65 / IP66 / IP69
UL 50 / UL 50E	Type 12 / 4 / 4X
Ambient temperature limits	-40 °C ... +125 °C
Mechanical life (cycles)	≥ 500



CEBUS® ECBT2.E115072 | ECBT8.E115072

Item	Description	Part No.	With cover	Entry	Dimension
	Bulkhead mounting housings, 1 lever, without gasket, with or without metal cover or SIMPLEX self-closing plastic cover	CZI 15 L	CZI 15 LS SIMPLEX cover CZI 15 LSP		
	Surface mounting housings, 1 lever, without gasket, with or without metal cover	MZP 15 L25 MZP 15 L225 CZP 15 L CZP 15 L2 CZP 15 L21 CZP 15 L221	MZP 15 LS25 MZP 15 LS225 CZP 15 LS CZP 15 LS2 CZP 15 LS21 CZP 15 LS221	M25 M25 × 2 Pg 16 Pg 16 × 2 Pg 21 Pg 21 × 2	
	Surface mounting housings, 1 lever, without gasket, with SIMPLEX self-closing plastic cover		MZP 15 LSP20 MZP 15 LSP25 CZP 15 LSP16 CZP 15 LSP21	M20 M25 Pg 16 Pg 21	
	Hoods, 1 lever, without gasket, top entry	MZV 15 LG20 CZV 15 LG		M20 Pg 13,5	
	Covers, 1 lever, without gasket - with loop 	CZC 15 LG			

Inserts size 49.16	Poles	Pages
CDA 16 A	10 + ⊕	B.16
CDC 16 A	10 + ⊕	B.19
CSAH 16 A	10 + ⊕	B.24
CD 10 A	15 + ⊕	B.30

Notes:
The enclosures ensure IP66/IP69 degree of protection (or IP65 for hinged cover versions) when mated and locked with the closing levers.

MIXO Modular Inserts	Pages
MIXO modules	C.12-93
CX 01 T (1-slot sized MIXO frames)	C.94

Enclosures with SIMPLEX self-closing cover ensure IP44 degree of protection when not mated and locked with lever.

Slim enclosures with IL-BRID lever

size **49.16**

Hoods and covers – 2 pegs

Heavy-Duty Applications


EN 60529	IP65 / IP66 / IP69
UL 50 / UL 50E	Type 12 / 4 / 4X
Ambient temperature limits	-40 °C ... +125 °C
Mechanical life (cycles)	≥ 500

ECBT2.E115072 | ECBT8.E115072

Item	Description	Side entry	Top entry	Entry	Dimension
	Hoods, 2 pegs, with gasket, side entry	MZO 15 L20 MZO 15 L25 CZO 15 L		M20 M25 Pg 16	
	Hoods, 2 pegs, with gasket, top entry		MZV 15 L20 CZV 15 L	M20 Pg 13,5	
	Hoods, 2 pegs, with gasket, side or top entry, high construction To be used only with a complete cable gland	MZFO 15 L20 MZFO 15 L25 CZFO 15 L16 CZFO 15 L21	MZFV 15 L20 MZFV 15 L25 CZFV 15 L16 CZFV 15 L21	M20 M25 Pg 16 Pg 21	
	Hoods, 2 pegs, with gasket, high construction, designed to be drilled	Without entry			
	Covers, 2 pegs, with gasket - with loop - or eyelet	With loop CZC 15 SL	With eyelet CZC 15 L		


Inserts size 49.16	Poles	Pages
CDA 16 A	10 + ⊕	B.16
CDC 16 A	10 + ⊕	B.19
CSAH 16 A	10 + ⊕	B.24
CD 10 A	15 + ⊕	B.30

MIXO Modular Inserts	Pages
MIXO modules	C.12-93
CX 01 T (1-slot sized MIXO frames)	C.94

Slim enclosures with IL-BRID lever

size **66.16**

Housings, hoods and covers – 1 lever


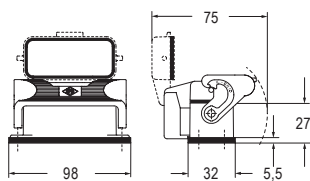

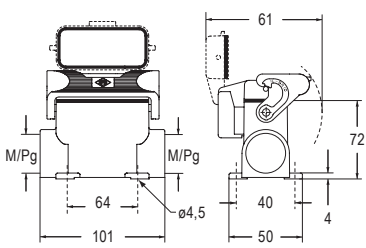

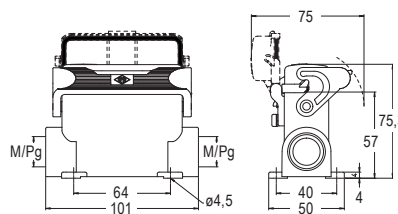

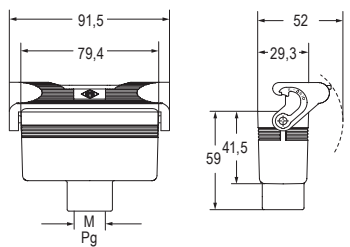

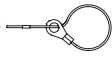
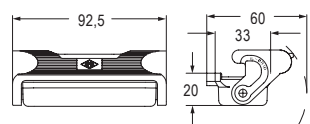
Heavy-Duty Applications 

CE UK CA

EN 60529	IP65 / IP66 / IP69
UL 50 / UL 50E	Type 12 / 4 / 4X
Ambient temperature limits	-40 °C ... +125 °C
Mechanical life (cycles)	≥ 500



CAIUS ECBT2.E115072 | ECBT8.E115072

Item	Description	Part No.	With cover	Entry	Dimension
	Bulkhead mounting housings, 1 lever, without gasket, with or without metal cover or SIMPLEX self-closing plastic cover	CZI 25 L	CZI 25 LS SIMPLEX cover CZI 25 LSP		
	Surface mounting housings, 1 lever, without gasket, with or without metal cover, high construction	MZAP 25 L25 MZAP 25 L225 CZAP 25 L CZAP 25 L2 CZAP 25 L21 CZAP 25 L221	MZAP 25 LS25 MZAP 25LS225 CZAP 25 LS CZAP 25 LS2 CZAP 25 LS21 CZAP 25LS221	M25 M25 × 2 Pg 16 Pg 16 × 2 Pg 21 Pg 21 × 2	
	Surface mounting housings, 1 lever, without gasket, with SIMPLEX self-closing plastic cover, high construction		MZAP 25LSP20 MZAP 25LSP25 CZAP 25LSP16 CZAP 25LSP21	M20 M25 Pg 16 Pg 21	
	Hoods, 1 lever, without gasket, top entry To be used only with a complete cable gland	MZV 25 LG20 CZV 25 LG		M20 Pg 16	
	Covers, 1 lever, without gasket For enclosures with 2 pegs and gasket with loop for hoods 	CZC 25 LG			

Inserts size 66.16		Poles	Pages
CDA	16 A	16 + ⊕	B.17
CDC	16 A	16 + ⊕	B.20
CSAH	16 A	16 + ⊕	B.25
CD	10 A	25 + ⊕	B.31
CDD	10 A	38 + ⊕	B.33

Notes:
The enclosures ensure IP66/IP69 degree of protection (or IP65 for hinged cover versions) when mated and locked with the closing levers.

Enclosures with SIMPLEX self-closing cover ensure IP44 degree of protection when not mated and locked with lever.

Slim enclosures with IL-BRID lever

size **66.16**

Hoods and covers – 2 pegs

Heavy-Duty Applications


EN 60529	IP65 / IP66 / IP69
UL 50 / UL 50E	Type 12 / 4 / 4X
Ambient temperature limits	-40 °C ... +125 °C
Mechanical life (cycles)	≥ 500

ECBT2.E115072 | ECBT8.E115072


Item	Description	Side entry	Top entry	Entry	Dimension
	Hoods, 2 pegs, with gasket, side entry	MZO 25 L20 MZO 25 L25 CZO 25 L		M20 M25 Pg 16	
	Hoods, 2 pegs, with gasket, top entry To be used only with a complete cable gland		MZV 25 L20 CZV 25 L	M20 Pg 16	
	Hoods, 2 pegs, with gasket, side or top entry, high construction To be used only with a complete cable gland	MZFO 25 L20 MZFO 25 L25 CZFO 25 L16 CZFO 25 L21	MZFV 25 L20 MZFV 25 L25 CZFV 25 L16 CZFV 25 L21	M20 M25 Pg 16 Pg 21	
	Hoods, 2 pegs, with gasket, 2 top entries, high construction To be used only with complete cable glands Hoods, 2 pegs, with gasket, high construction, designed to be drilled		MZFV 25 L220 CZFV 25 L216	M20 × 2 Pg 16 × 2	
	Covers, 2 pegs, with gasket For enclosures with 1 lever without gasket with loop for hoods or with eyelet for housings	Without entry CZAC 25 L	With loop CZC 25 SL	With eyelet CZC 25 L	

Inserts size 66.16	Poles	Pages
CDA	16 A	16 + ⊕ B.17
CDC	16 A	16 + ⊕ B.20
CSAH	16 A	16 + ⊕ B.25
CD	10 A	25 + ⊕ B.31
CDD	10 A	38 + ⊕ B.33

Slim enclosures with JEI®-P lever

Housings and hoods – 1 lever

size **49.16**


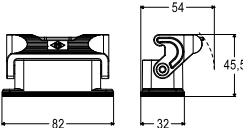

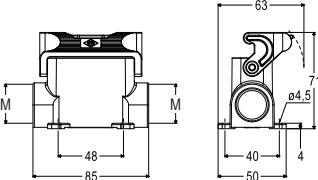

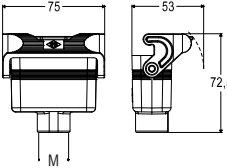


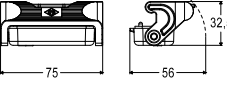
Heavy-Duty Applications 

CE UK CA

CEC DNV SIFITA

EN 60529	IP65
UL 50 / UL 50E	Type 12 / 4 / 4X
Ambient temperature limits	-40 °C ... +125 °C
Mechanical life (cycles)	≥ 500

CAUS ECBT2.E115072 | ECBT8.E115072

Item	Description	Part No.	Entry	Dimension
	Bulkhead mounting housings, 1 lever, without gasket	JPI 15 L		
	Surface mounting housings, 1 lever, without gasket	JMPP 15 L25 JMPP 15 L225	M25 M25 × 2	
	Hoods, 1 lever, without gasket, top entry	JMPV 15 LG20	M20	
	Cover, 1 lever, without gasket For enclosures with 2 pegs and gasket with loop for hoods 	JPC 15 LG		

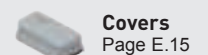
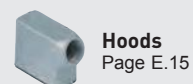
JEI®-P

E

Inserts size 49.16	Poles	Pages
CDA 16 A	10 + ⊕	B.16
CDC 16 A	10 + ⊕	B.19
CSAH 16 A	10 + ⊕	B.24
CD 10 A	15 + ⊕	B.30

MIXO Modular Inserts	Pages
MIXO modules	C.12-93
CX 01 T (1-slot sized MIXO frames)	C.94

Complete with:



Slim enclosures with JEI®-P lever

Housings and hoods – 1 lever

size **66.16**
Heavy-Duty Applications
CE UK


EN 60529	IP65
UL 50 / UL 50E	Type 12 / 4 / 4X
Ambient temperature limits	-40 °C ... +125 °C
Mechanical life (cycles)	≥ 500

CAIUS ECBT2.E115072 | ECBT8.E115072

Item	Description	Part No.	Entry	Dimension
	Bulkhead mounting housings, 1 lever, without gasket	JPI 25 L		
	Surface mounting housings, 1 lever, without gasket	JMPP 25 L25 JMPP 25 L225	M25 M25 × 2	
	Hoods, 1 lever, without gasket, top entry	JMPV 25 LG20	M20	
	Cover, 1 lever, without gasket For enclosures with 2 pegs and gasket with loop for hoods	JPC 25 LG		

JEI®-P

E

Inserts size 66.16	Poles	Pages
CDA 16 A	16 + ⊕	B.17
CDC 16 A	16 + ⊕	B.20
CSAH 16 A	16 + ⊕	B.25
CD 10 A	25 + ⊕	B.31
CDD 10 A	38 + ⊕	B.33

Complete with:



Hoods
Page E.17

Covers
Page E.17

Slim enclosures with C-TYPE lever

size **66.40**

Housings, hoods and covers – 2 levers


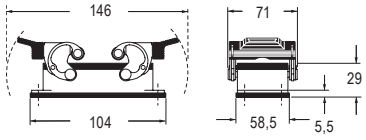

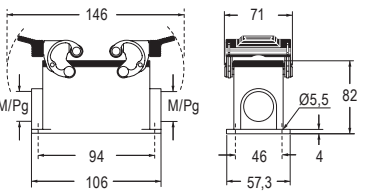

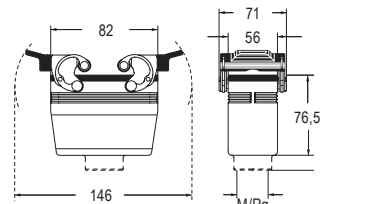


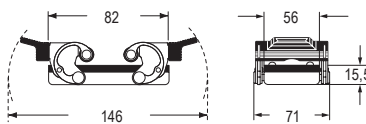
Heavy-Duty Applications 

CE UK CA

EN 60529	IP65 / IP66 / IP69
UL 50 / UL 50E	Type 12 / 4 / 4X
Ambient temperature limits	-40 °C ... +125 °C
Mechanical life (cycles)	≥ 500




CAIUS ECBT2.E115072 | ECBT8.E115072

Item	Description	Part No.	Entry	Dimension
	Bulkhead mounting housings, 2 levers and gasket	CHI 50		
	Surface mounting housings, 2 levers and gasket	MHP 50.32 MHP 50.232 MHP 50.40 MHP 50.240 CHP 50.21 CHP 50.221 CHP 50.29 CHP 50.229	M32 M32 × 2 M40 M40 × 2 Pg 21 Pg 21 × 2 Pg 29 Pg 29 × 2	
	Hoods, 2 levers and gasket, top entry To be used only with a complete cable gland	MFV 50 G32 CFV 50 G29	M32 Pg 29	
	Covers, 2 levers and gasket For enclosures with 4 pegs without gasket with loop for hoods 	CHC 50 G		

C-TYPE

E

Inserts size (66.16) × 2	Poles 	Pages
CDA 16 A	32 + ⊕	B.18
CDC 16 A	32 + ⊕	B.21
CSAH 16 A	32 + ⊕	B.26
CD 10 A	50 + ⊕	B.32
CDD 10 A	76 + ⊕	B.34

Slim enclosures with C-TYPE lever

size **66.40**

Hoods and covers – 4 pegs

Heavy-Duty Applications
CE UK


EN 60529	IP65 / IP66 / IP69
UL 50 / UL 50E	Type 12 / 4 / 4X
Ambient temperature limits	-40 °C ... +125 °C
Mechanical life (cycles)	≥ 500

ALUS ECBT2.E115072 | ECBT8.E115072

Item	Description	Side entry	Top entry	Entry	Dimension
	Hoods, 4 pegs without gasket, side entry	MHO 50.25 MHO 50.32 CHO 50		M25 M32 Pg 21	
	Hoods, 4 pegs without gasket, side or top entry, high construction To be used only with a complete cable gland	MFO 50.25 MFO 50.32 CFO 50.21 CFO 50.29	MFV 50.25 MFV 50.32 CFV 50.21 CFV 50.29	M25 M32 Pg 21 Pg 29	
	Hoods, 4 pegs without gasket, high construction, designed to be drilled	Without entry CAC 50			
	Covers, 4 pegs, without gasket For enclosures with 2 levers and gasket with loop for hoods or with eyelet for housings	With loop CHC 50 S	With eyelet CHC 50		

C-TYPE

E

Inserts size (66.16) × 2	Poles	Pages
CDA 16 A	32 + ⊕	B.18
CDC 16 A	32 + ⊕	B.21
CSAH 16 A	32 + ⊕	B.26
CD 10 A	50 + ⊕	B.32
CDD 10 A	76 + ⊕	B.34

Slim enclosures with C-TYPE lever

Housings – 4 pegs

size **66.40**


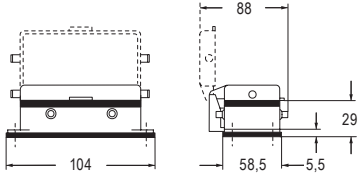

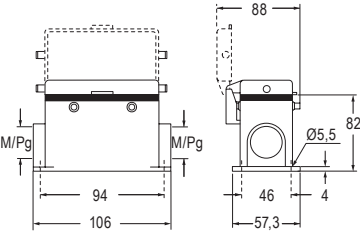
Heavy-Duty Applications 

CE UK CA

CEC DNV SIFITA

EN 60529	IP65 / IP66 / IP69
UL 50 / UL 50E	Type 12 / 4 / 4X
Ambient temperature limits	-40 °C ... +125 °C
Mechanical life (cycles)	≥ 500

CAUS ECBT2.E115072 | ECBT8.E115072

Item	Description	Part No.	With cover	Entry	Dimension
	Bulkhead mounting housings, 4 pegs and gasket, with metal cover		CHI 50 CS		
	Surface mounting housings, 4 pegs and gasket, with metal cover		MHP 50 CS32 MHP 50 LS232 MHP 50 LS40 MHP 50 LS240 CHP 50 LS21 CHP 50 LS221 CHP 50 LS29 CHP 50 LS229	M32 M32 × 2 M40 M40 × 2 Pg 21 Pg 21 × 2 Pg 29 Pg 29 × 2	

C-TYPE

E

Inserts size (66.16) × 2	Poles 	Pages
CDA 16 A	32 + ⊕	B.18
CDC 16 A	32 + ⊕	B.21
CSAH 16 A	32 + ⊕	B.26
CD 10 A	50 + ⊕	B.32
CDD 10 A	76 + ⊕	B.34

Slim enclosures with C-TYPE lever


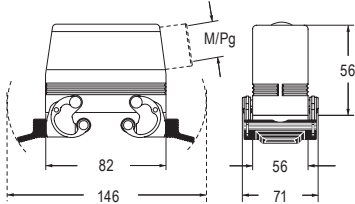


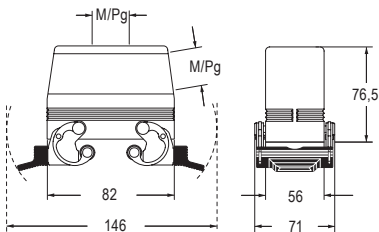
size **66.40**

Hoods – 2 levers

Heavy-Duty Applications
CE UK


EN 60529	IP65 / IP66 / IP69
UL 50 / UL 50E	Type 12 / 4 / 4X
Ambient temperature limits	-40 °C ... +125 °C
Mechanical life (cycles)	≥ 500

CEC ECBT2.E115072 | ECBT8.E115072

Item	Description	Side entry	Top entry	Entry	Dimension
	Hoods, 2 levers, without gasket, side entry To be used only with a complete cable gland	MHO 50 X25 MHO 50 X32 CHO 50 X		M25 M32 Pg 21	
 	Hoods, 2 levers, without gasket, side or top entry, high construction To be used only with a complete cable gland	MFO 50 X25 MFO 50 X32 CFO 50 X CFO 50 X29	MFV 50 X25 MFV 50 X32 CFV 50 X CFV 50 X29	M25 M32 Pg 21 Pg 29	

C-TYPE


E

Inserts size (66.16) × 2	Poles	Pages
CDA	16 A	32 + ⊕ B.18
CDC	16 A	32 + ⊕ B.21
CSAH	16 A	32 + ⊕ B.26
CD	10 A	50 + ⊕ B.32
CDD	10 A	76 + ⊕ B.34

Slim enclosures with full metal C-TYPE lever

size **66.40**

Housings, hoods and covers – 2 levers


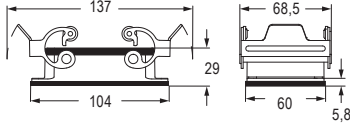

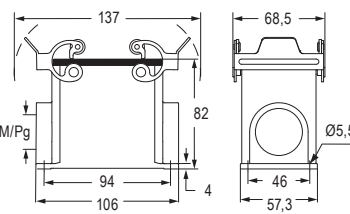

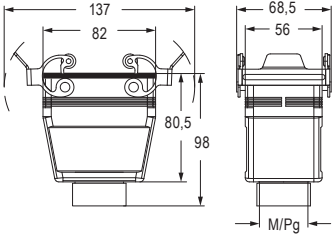

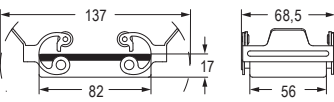
Heavy-Duty Applications 

CE UK CA


CEC DNV SIFITA

EN 60529	IP66 / IP69
UL 50 / UL 50E	Type 12 / 4 / 4X
Ambient temperature limits	-40 °C ... +125 °C
Mechanical life (cycles)	≥ 500

CAIUS ECBT2.E115072 | ECBT8.E115072

Item	Description	Part No.	With cover	Entry	Dimension
	Bulkhead mounting housings, 2 full metal locking levers and gasket	CHIX 50			
	Surface mounting housings, 2 full metal locking levers and gasket	MHPX 50.32 CHPX 50.21 CHPX 50.29		M32 Pg 21 Pg 29	
	Hoods, 2 full metal locking levers and gasket, top entry, with metal adapter	MAVX 50 G32 CAVX 50 G29		M32 Pg 29	
	Covers, with 2 full metal locking levers and gasket For enclosures with 4 pegs without gasket	CHCX 50 G			

C-TYPE
E

Inserts size (66.16) × 2	Poles 	Pages
CDA 16 A	32 + ⊕	B.18
CDC 16 A	32 + ⊕	B.21
CSAH 16 A	32 + ⊕	B.26
CD 10 A	50 + ⊕	B.32
CDD 10 A	76 + ⊕	B.34

Slim enclosures with full metal C-TYPE lever

size **66.40**

Housings – 2 levers

Heavy-Duty Applications
CE UK


EN 60529	IP66 / IP69
UL 50 / UL 50E	Type 12 / 4 / 4X
Ambient temperature limits	-40 °C ... +125 °C
Mechanical life (cycles)	≥ 500

CAIUS ECBT2.E115072 | ECBT8.E115072


Item	Description	Side entry	Top Entry	Entry	Dimension
	Hoods, 2 full metal locking levers, without gasket, side entry	MHOX 50 X32 CHOX 50 X		M32 Pg 21	
	Hoods, 2 full metal locking levers, without gasket, side or top entry, high construction To be used only with a complete cable gland	MFOX 50 X32	MFXV 50 X32	M32	

Inserts size (66.16) × 2	Poles	Pages
CDA	16 A	32 + ⊕ B.18
CDC	16 A	32 + ⊕ B.21
CSAH	16 A	32 + ⊕ B.26
CD	10 A	50 + ⊕ B.32
CDD	10 A	76 + ⊕ B.34

Slim enclosures – Rigid lever – IP67

size **49.16**


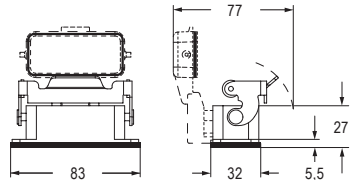

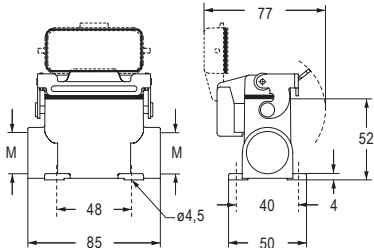

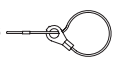
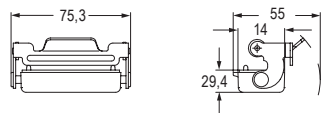
Housings and covers – 1 lever

Heavy-Duty Applications 

EN 60529	IP65 / IP66 / IP67 / IP69
UL 50 / UL 50E	Type 12 / 4 / 4X
Ambient temperature limits	-40 °C ... +125 °C
Mechanical life (cycles)	≥ 500



ILME® ECBT2.E115072 | ECBT8.E115072

Item	Description	Part No.	With cover	Entry	Dimension
	Bulkhead mounting housings, 1 stainless steel rigid lever, without gasket, with or without metal cover	CZ7I 15 L	CZ7I 15 LS		
	Surface mounting housings, 1 stainless steel rigid lever, without gasket, with or without metal cover	MZ7P 15 L25 MZ7P 15 L225	MZ7P 15 LS25 MZ7P 15LS225	M25 M25 × 2	
	Cover, 1 stainless steel rigid lever, without gasket Covers cannot be used together with metal coding pins For enclosures with 2 pegs and gasket with loop for hoods 	CZ7C 15 LG			

CZ7 / MZ7

E

Inserts size 49.16	Poles	Pages
CDA 16 A	10 + ⊕	B.16
CDC 16 A	10 + ⊕	B.19
CSAH 16 A	10 + ⊕	B.24
CD 10 A	15 + ⊕	B.30

Note:
The rigid lever offers an IP66/IP67/IP69 degree of protection (according to EN 60529) when fitted with a complete and coupled connector and used with ILME standard hoods in die cast aluminum with pegs (without adapter).

Complete with:



MIXO Modular Inserts	Pages
MIXO modules	C.12-93
CX 01 T (1-slot sized MIXO frames)	C.94

Slim enclosures – Rigid lever – IP67

size **66.16**

Housings and covers – 1 lever

Heavy-Duty Applications


EN 60529	IP65 / IP66 / IP67 / IP69
UL 50 / UL 50E	Type 12 / 4 / 4X
Ambient temperature limits	-40 °C ... +125 °C
Mechanical life (cycles)	≥ 500

ECBT2.E115072 | ECBT8.E115072

Item	Description	Part No.	With cover	Entry	Dimension
	Bulkhead mounting housings, 1 stainless steel rigid lever, without gasket, with or without metal cover	CZ7I 25 L	CZ7I 25 LS		
	Surface mounting housings, 1 stainless steel rigid lever, without gasket, with or without metal cover	MZ7P 25 L25 MZ7P 25 L225	MZ7P 25 LS25 MZ7P 25LS225	M25 M25 × 2	
	Cover, 1 stainless steel rigid lever, without gasket Covers cannot be used together with metal coding pins For enclosures with 2 pegs and gasket with loop for hoods	CZ7C 25 LG			

CZ7 / MZ7

E

Inserts size 66.16	Poles	Pages
CDA 16 A	16 + ⊕	B.17
CDC 16 A	16 + ⊕	B.20
CSAH 16 A	16 + ⊕	B.25
CD 10 A	25 + ⊕	B.31
CDD 10 A	38 + ⊕	B.33

Note:

The rigid lever offers an IP66/IP67/IP69 degree of protection (according to EN 60529) when fitted with a complete and coupled connector and used with ILME standard hoods in die cast aluminum with pegs (without adapter).

Complete with:
Hoods
Page E.17

Covers
Page E.17

Slim enclosures – W-TYPE series


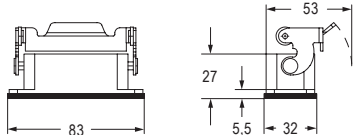

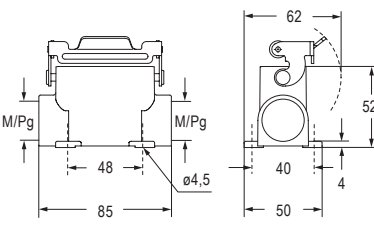

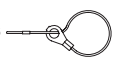
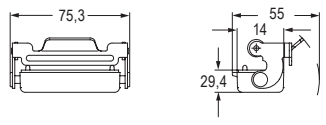
Housings and covers – 1 lever

size **49.16**



RAUS ECBT2.E115072 | ECBT8.E115072

EN 60529	IP65 / IP66 / IP67 / IP69
UL 50 / UL 50E	Type 12 / 4 / 4X
Ambient temperature limits	-40 °C ... +125 °C
Mechanical life (cycles)	≥ 500

Item	Description	Part No.	Entry	Dimension
	Bulkhead mounting housings, 1 stainless steel rigid lever, without gasket	CZ7IW 15 L		
	Surface mounting housings, 1 stainless steel rigid lever, without gasket	MZ7PW 15L225 CZ7PW 15 L2	M25 × 2 Pg 16 × 2	
	Cover, 1 stainless steel rigid lever, without gasket Covers cannot be used together with metal coding pins For enclosures with 2 pegs and gasket with loop for hoods 	CZ7CW 15 LG		

W-TYPE

E

Inserts size 49.16	Poles	Pages
CDA 16 A	10 + ⊕	B.16
CDC 16 A	10 + ⊕	B.19
CSAH 16 A	10 + ⊕	B.24
CD 10 A	15 + ⊕	B.30

MIXO Modular Inserts	Pages
MIXO modules	C.12-93
CX 01 T (1-slot sized MIXO frames)	C.94

Slim enclosures – W-TYPE series


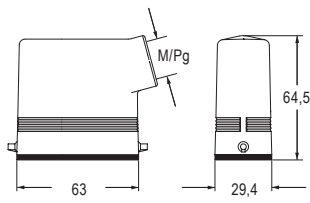

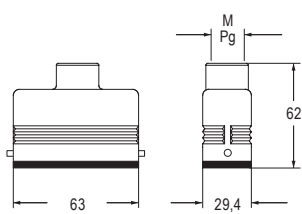

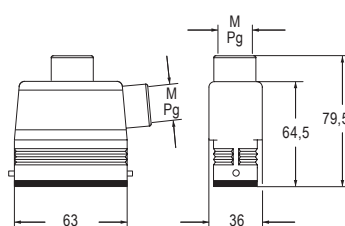

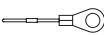
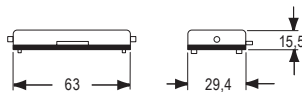
size **49.16**

Hoods and covers– 2 pegs

Aggressive Environments
CE UK


EN 60529	IP65 / IP66 / IP67 / IP69
UL 50 / UL 50E	Type 12 / 4 / 4X
Ambient temperature limits	-40 °C ... +125 °C
Mechanical life (cycles)	≥ 500

CAIUS ECBT2.E115072 | ECBT8.E115072

Item	Description	Side entry	Top entry	Entry	Dimension
	Hoods, 2 pegs, with gasket, side entry	MZOW 15 L20 MZOW 15 L25 CZOW 15 L		M20 M25 Pg 16	
	Hoods, 2 pegs, with gasket, top entry		MZVW 15 L20 CZVW 15 L	M20 Pg 13,5	
	Hoods, 2 pegs, with gasket, side or top entry, high construction, with metal adapter	MZAOW 15 L25 CZAOW 15 L21	MZAVW 15 L25 CZAVW 15 L21	M25 Pg 21	
	Cover, 2 pegs and gasket Covers cannot be used together with metal coding pins For enclosures with 1 lever without gasket with eyelet for housings 		With eyelet CZCW 15 L		

W-TYPE

E

Inserts size 49.16	Poles	Pages
CDA 16 A	10 + ⊕	B.16
CDC 16 A	10 + ⊕	B.19
CSAH 16 A	10 + ⊕	B.24
CD 10 A	15 + ⊕	B.30

MIXO Modular Inserts	Pages
MIXO modules	C.12-93
CX 01 T (1-slot sized MIXO frames)	C.94

Slim enclosures – W-TYPE series

size **66.16**

Housings and covers – 1 lever


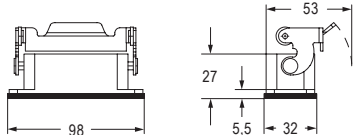

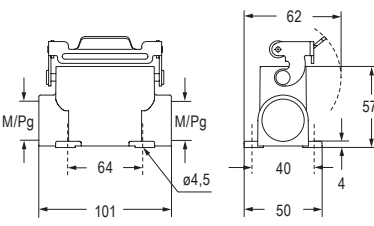


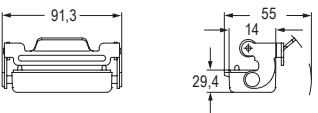
Aggressive Environments 

CE UK CA

EN 60529	IP65 / IP66 / IP67 / IP69
UL 50 / UL 50E	Type 12 / 4 / 4X
Ambient temperature limits	-40 °C ... +125 °C
Mechanical life (cycles)	≥ 500



CAUS® ECBT2.E115072 | ECBT8.E115072

Item	Description	Part No.	Entry	Dimension
	Bulkhead mounting housings, 1 stainless steel rigid lever, without gasket	CZ7IW 25 L		
	Surface mounting housings, 1 stainless steel rigid lever, without gasket	MZ7PW 25L225 CZ7PW 25 L2	M25 × 2 Pg 16 × 2	
	Cover, 1 stainless steel rigid lever, without gasket Covers cannot be used together with metal coding pins For enclosures with 2 pegs and gasket with loop for hoods 	CZ7CW 25 LG		

W-TYPE

E

Inserts size 66.16	Poles	Pages
CDA 16 A	16 + ⊕	B.17
CDC 16 A	16 + ⊕	B.20
CSAH 16 A	16 + ⊕	B.25
CD 10 A	25 + ⊕	B.31
CDD 10 A	38 + ⊕	B.33

Slim enclosures – W-TYPE series

size **66.16**

Hoods and covers– 2 pegs


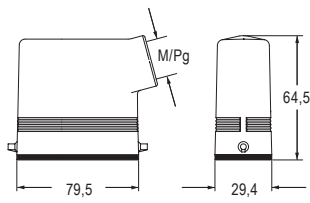

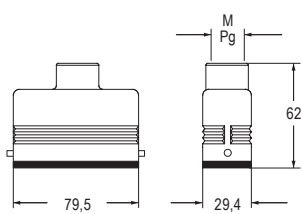

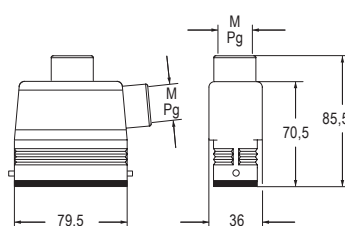

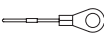
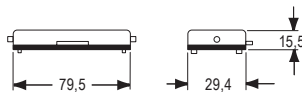
Aggressive Environments 

CE UK



EN 60529	IP65 / IP66 / IP67 / IP69
UL 50 / UL 50E	Type 12 / 4 / 4X
Ambient temperature limits	-40 °C ... +125 °C
Mechanical life (cycles)	≥ 500

 ECBT2.E115072 | ECBT8.E115072

Item	Description	Side entry	Top entry	Entry	Dimension
	Hoods, 2 pegs, with gasket, side entry	MZOW 25 L20 MZOW 25 L25 CZOW 25 L		M20 M25 Pg 16	
	Hoods, 2 pegs, with gasket, top entry To be used only with a complete cable gland		MZVW 25 L20 CZVW 25 L	M20 Pg 16	
	Hoods, 2 pegs, with gasket, side or top entry, high construction, with metal adapter	MZAOW 25 L25 CZAOW 25 L21	MZAVW 25 L25 CZAVW 25 L21	M25 Pg 21	
	Cover, 2 pegs and gasket Covers cannot be used together with metal coding pins For enclosures with 1 lever without gasket with eyelet for housings 		With eyelet CZCW 25 L		

W-TYPE

E

Inserts size 66.16	Poles	Pages
CDA 16 A	16 + ⊕	B.17
CDC 16 A	16 + ⊕	B.20
CSAH 16 A	16 + ⊕	B.25
CD 10 A	25 + ⊕	B.31
CDD 10 A	38 + ⊕	B.33

Slim enclosures – W-TYPE series

size **66.40**


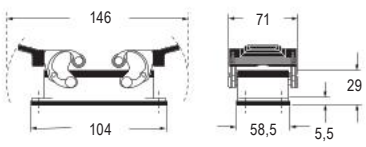

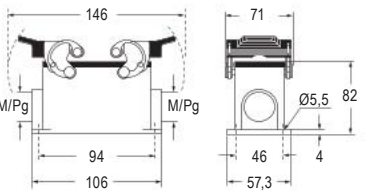

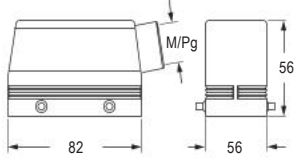

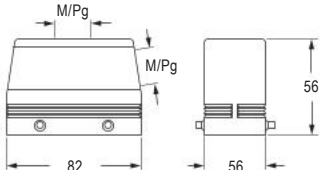



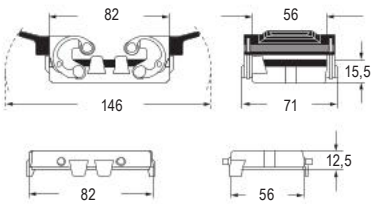
Housings and covers – 2 levers

Hoods and covers – 4 pegs



EN 60529	IP65 / IP66 / IP69
UL 50 / UL 50E	Type 12 / 4 / 4X
Ambient temperature limits	-40 °C ... +125 °C
Mechanical life (cycles)	≥ 500

RAUS ECBT2.E115072 | ECBT8.E115072

Item	Description	Part No.	Entry	Dimension	
	Bulkhead mounting housings, 2 levers and gasket	CHIW 50			
	Surface mounting housings, 2 levers and gasket	MHPW 50.32 MHPW 50.240 CHPW 50.21 CHPW 50.229	M32 M40 × 2 Pg 21 Pg 29 × 2		
	Hoods, 4 pegs, without gasket, side entry	Side entry MHOW 50.25 MHOW 50.32 CHOW 50	M25 M32 Pg 21		
	Hoods, 4 pegs, without gasket, side or top entry, high construction, with metal adapter	Side entry MAOW 50.32 CAOW 50.29	Top entry MAVW 50.32 CAVW 50.29	M32 Pg 29	
	Covers, with 2 levers and gasket (for enclosures with 4 pegs without gasket) or with 4 pegs, without gasket (for enclosures with 2 levers and gasket) with loop for hoods  or with eyelet for housings 	With 2 levers and loop CHCW 50 G With 4 pegs and loop CHCW 50 S	With 4 pegs and eyelet CHCW 50		

Inserts size (66.16) × 2	Poles	Pages
CDA 16 A	32 + ⊕	3.18
CDC 16 A	32 + ⊕	3.21
CSAH 16 A	32 + ⊕	3.26
CD 10 A	50 + ⊕	3.32
CDD 10 A	76 + ⊕	3.34

Slim enclosures – W-TYPE series

size **66.40**


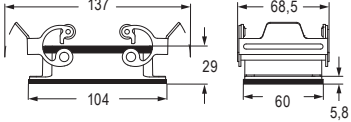

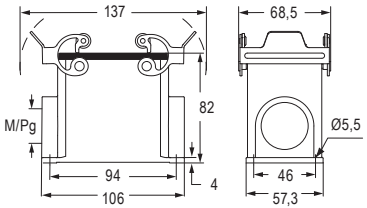

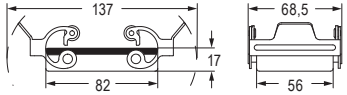
Housings and covers – 2 levers

**Aggressive
Environments**

**CE UK
CA**

CAIUS ECBT2.E115072 | ECBT8.E115072

EN 60529	IP65 / IP66 / IP69
UL 50 / UL 50E	Type 12 / 4 / 4X
Ambient temperature limits	-40 °C ... +125 °C
Mechanical life (cycles)	≥ 500

Item	Description	Part No.	Entry	Dimension
	Bulkhead mounting housings, 2 full metal locking levers and gasket	CHIXW 50		
	Surface mounting housings, 2 full metal locking levers and gasket	MHPXW 50.32 CHPXW 50.21	M32 Pg 21	
	Covers, with 2 full metal locking levers and gasket For enclosures with 4 pegs without gasket	CHCXW 50 G		

W-TYPE

E

Inserts size (66.16) × 2	Poles	Pages
CDA 16 A	32 + ⊕	B.18
CDC 16 A	32 + ⊕	B.21
CSAH 16 A	32 + ⊕	B.26
CD 10 A	50 + ⊕	B.32
CDD 10 A	76 + ⊕	B.34

Slim enclosures – E-Xtreme®

size **49.16**

Housings and covers – 1 lever

2 000 hrs resistance
in salt-spray tests




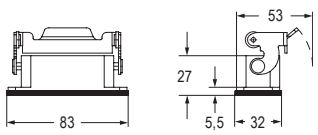

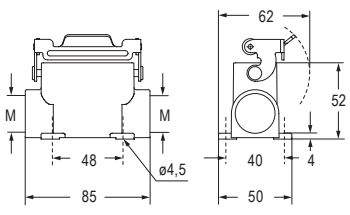

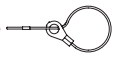
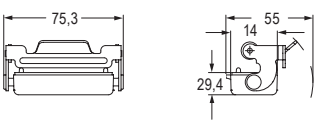
Aggressive
Environments



EN 60529	IP65 / IP66 / IP67 / IP69
UL 50 / UL 50E	Type 12 / 4 / 4X
Ambient temperature limits	-40 °C ... +125 °C
Mechanical life (cycles)	≥ 500



CEC US ECBT2.E115072 | ECBT8.E115072

Item	Description	Part No.	Entry	Dimension
	Bulkhead mounting housings, 1 lever, without gasket	CZ7IE 15 L		
	Surface mounting housings, 1 lever, without gasket	M27PE 15L225	M25 × 2	
	Cover, 1 lever, without gasket For enclosures with 2 pegs and gasket with loop for hoods 	CZ7CE 15 LG		

E-Xtreme®

E

Inserts size 49.16	Poles	Pages
CDA 16 A	10 + ⊕	B.16
CDC 16 A	10 + ⊕	B.19
CSAH 16 A	10 + ⊕	B.24
CD 10 A	15 + ⊕	B.30

MIXO Modular Inserts	Pages
MIXO modules	C.12-93
CX 01 T (1-slot sized MIXO frames)	C.94

Slim enclosures – E-Xtreme®

size **49.16**

Hoods and covers – 2 pegs


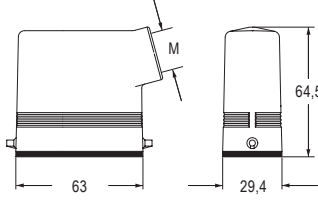

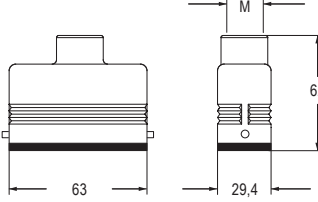

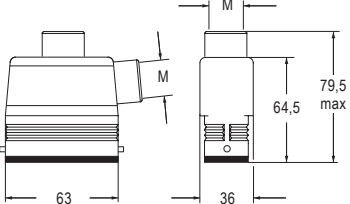
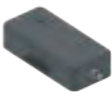
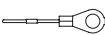
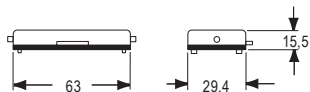
2 000 hrs resistance
 in salt-spray tests

Aggressive
Environments


EN 60529	IP65 / IP66 / IP67 / IP69
UL 50 / UL 50E	Type 12 / 4 / 4X
Ambient temperature limits	-40 °C ... +125 °C
Mechanical life (cycles)	≥ 500

CE UK

ALUS ECBT2.E115072 | ECBT8.E115072

Item	Description	Side entry	Top entry	Entry	Dimension
	Hoods, 2 pegs and gasket, side entry	MZOE 15 L20 MZOE 15 L25		M20 M25	
	Hoods, 2 pegs and gasket, top entry		MZVE 15 L20	M20	
	Hoods, 2 pegs and gasket, side or top entry, high construction, with metal adapter	MZAQE 15 L25	MZAVE 15 L25	M25	
	Cover, 2 pegs and gasket For enclosures with 1 lever without gasket with eyelet for housings 		With eyelet CZCE 15 L		

Inserts size 49.16	Poles	Pages
CDA 16 A	10 + ⊕	B.16
CDC 16 A	10 + ⊕	B.19
CSAH 16 A	10 + ⊕	B.24
CD 10 A	15 + ⊕	B.30

MIXO Modular Inserts	Pages
MIXO modules	C.12-93
CX 01 T (1-slot sized MIXO frames)	C.94

Slim enclosures – E-Xtreme®

size **66.16**

Housings and covers – 1 lever

2 000 hrs resistance
in salt-spray tests



Aggressive
Environments


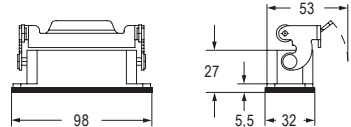

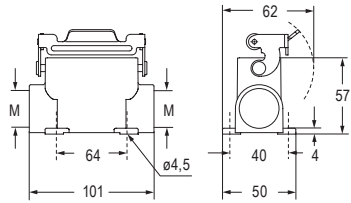


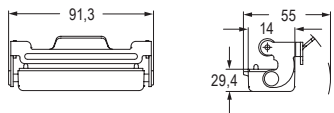


EN 60529	IP65 / IP66 / IP67 / IP69
UL 50 / UL 50E	Type 12 / 4 / 4X
Ambient temperature limits	-40 °C ... +125 °C
Mechanical life (cycles)	≥ 500

CE UK
CA



CAUS ECBT2.E115072 | ECBT8.E115072

Item	Description	Part No.	Entry	Dimension
	Bulkhead mounting housings, 1 lever, without gasket	CZ7IE 25 L		
	Surface mounting housings, 1 lever, without gasket	MZ7PE 25L225	M25 × 2	
	Cover, 1 lever, without gasket For enclosures with 2 pegs and gasket with loop for hoods 	CZ7CE 25 LG		

E-Xtreme®

E

Inserts size 66.16	Poles	Pages
CDA 16 A	16 + ⊕	B.17
CDC 16 A	16 + ⊕	B.20
CSAH 16 A	16 + ⊕	B.25
CD 10 A	25 + ⊕	B.31
CDD 10 A	38 + ⊕	B.33

Slim enclosures – E-Xtreme®

size **66.16**


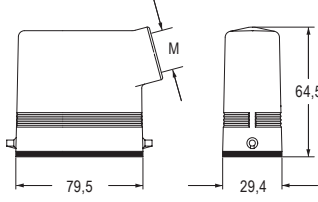

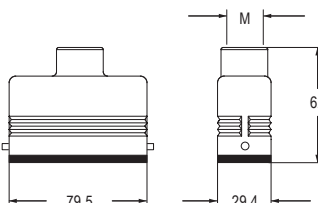

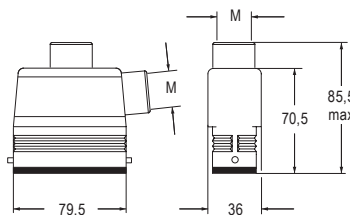

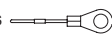
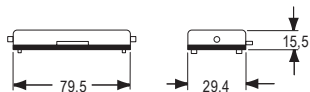
Hoods and covers – 2 pegs

2 000 hrs resistance
in salt-spray testsAggressive
Environments

EN 60529	IP65 / IP66 / IP67 / IP69
UL 50 / UL 50E	Type 12 / 4 / 4X
Ambient temperature limits	-40 °C ... +125 °C
Mechanical life (cycles)	≥ 500

CE UK

C[®]ALUS ECBT2.E115072 | ECBT8.E115072

Item	Description	Side entry	Top entry	Entry	Dimension
	Hoods, 2 pegs and gasket, side entry	MZOE 25 L20 MZOE 25 L25		M20 M25	
	Hoods, 2 pegs and gasket, top entry To be used only with a complete cable gland		MZVE 25 L20	M20	
	Hoods, 2 pegs and gasket, side or top entry, high construction, with metal adapter	MZAQE 25 L25	MZAVE 25 L25	M25	
	Cover, 2 pegs and gasket For enclosures with 1 lever without gasket with eyelet for housings 		With eyelet CZCE 25 L		

E-Xtreme®

E

Inserts size 66.16	Poles	Pages
CDA 16 A	16 + ⊕	B.17
CDC 16 A	16 + ⊕	B.20
CSAH 16 A	16 + ⊕	B.25
CD 10 A	25 + ⊕	B.31
CDD 10 A	38 + ⊕	B.33

Slim enclosures – E-Xtreme®

size **66.40**

Housings, hoods and covers – 2 levers

2 000 hrs resistance
in salt-spray tests



Aggressive
Environments


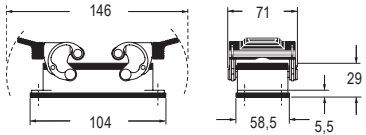

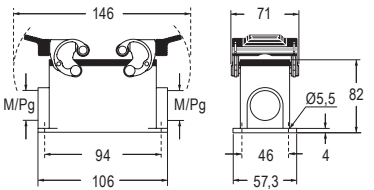


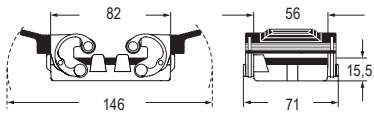


EN 60529	IP65 / IP66 / IP69
UL 50 / UL 50E	Type 12 / 4 / 4X
Ambient temperature limits	-40 °C ... +125 °C
Mechanical life (cycles)	≥ 500

CE UK



CAUS® ECBT2.E115072 | ECBT8.E115072

Item	Description	Part No.	Entry	Dimension
	Bulkhead mounting housings, 2 levers and gasket	CHIE 50		
	Surface mounting housings, 2 levers and gasket	MHPE 50.32 MHPE 50.240	M32 M40 × 2	
	Covers, 2 levers and gasket For enclosures with 4 pegs without gasket with loop for hoods 	CHCE 50 G		

E-Xtreme®

E

Inserts size (66.16) × 2	Poles	Pages
CDA 16 A	32 + ⊕	B.18
CDC 16 A	32 + ⊕	B.21
CSAH 16 A	32 + ⊕	B.26
CD 10 A	50 + ⊕	B.32
CDD 10 A	76 + ⊕	B.34

Slim enclosures – E-Xtreme®


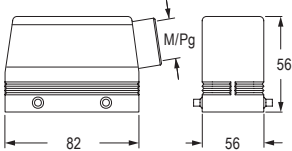

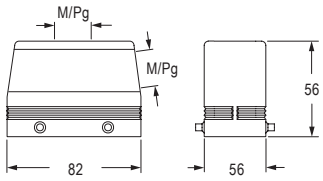
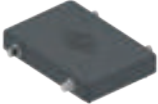
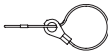
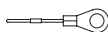
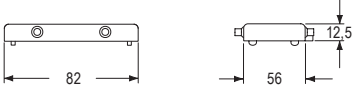
size **66.40**


Hoods and covers – 4 pegs

2 000 hrs resistance
in salt-spray testsAggressive
Environments

EN 60529	IP65 / IP66 / IP69
UL 50 / UL 50E	Type 12 / 4 / 4X
Ambient temperature limits	-40 °C ... +125 °C
Mechanical life (cycles)	≥ 500

CE UK
CAC^{RU} ECBT2.E115072 | ECBT8.E115072


Item	Description	Side entry	Top entry	Entry	Dimension
	Hoods, 4 pegs, without gasket, side entry	MHOE 50.25 MHOE 50.32		M25 M32	
	Hoods, 4 pegs, without gasket, side or top entry, high construction, with metal adapter	MAOE 50.32	MAVE 50.32	M32	
	Covers, 4 pegs, without gasket For enclosures with 2 levers and gasket with loop for hoods  or with eyelet for housings 	With loop CHCE 50 S	With eyelet CHCE 50		

Inserts size (66.16) × 2	Poles 	Pages
CDA 16 A	32 + ⊕	B.18
CDC 16 A	32 + ⊕	B.21
CSAH 16 A	32 + ⊕	B.26
CD 10 A	50 + ⊕	B.32
CDD 10 A	76 + ⊕	B.34

Slim enclosures – EMC series

size **49.16**


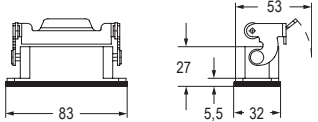

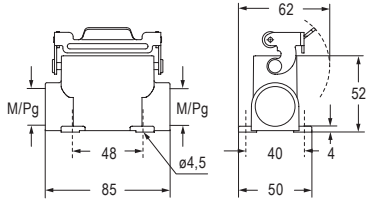


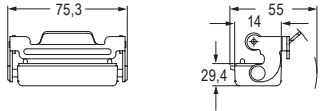
Housings and covers – 1 lever

Specialized Applications 

EN 60529	IP65 / IP66 / IP67 / IP69
UL 50 / UL 50E	Type 12 / 4 / 4X
Ambient temperature limits	-40 °C ... +125 °C
Mechanical life (cycles)	≥ 500



RAUS ECBT2.E115072 | ECBT8.E115072

Item	Description	Part No.	Entry	Dimension
	Bulkhead mounting housings, 1 lever, without gasket	CZ7IS 15 L		
	Surface mounting housings, 1 lever, without gasket	MZ7PS 15L225 CZ7PS 15 L2	M25 × 2 Pg 16 × 2	
	Cover, 1 lever, without gasket For enclosures with 2 pegs and gasket with loop for hoods 	CZ7CS 15 LG		

EMC

E

Inserts size 49.16	Poles	Pages
CDA 16 A	10 + ⊕	B.16
CDC 16 A	10 + ⊕	B.19
CSAH 16 A	10 + ⊕	B.24
CD 10 A	15 + ⊕	B.30

MIXO Modular Inserts	Pages
MIXO modules	C.12-93
CX 01 T (1-slot sized MIXO frames)	C.94

Slim enclosures – EMC series

size **49.16**

Hoods and covers – 2 pegs

Specialized Applications



EN 60529	IP65 / IP66 / IP67 / IP69
UL 50 / UL 50E	Type 12 / 4 / 4X
Ambient temperature limits	-40 °C ... +125 °C
Mechanical life (cycles)	≥ 500

ECBT2.E115072 | ECBT8.E115072

Item	Description	Side entry	Top entry	Entry	Dimension
	Hoods, 2 pegs and gasket, side entry	MZOS 15 L20 MZOS 15 L25 CZOS 15 L		M20 M25 Pg 16	
	Hoods, 2 pegs and gasket, top entry		MZVS 15 L20 CZVS 15 L	M20 Pg 13,5	
	Hoods, 2 pegs and gasket, side or top entry, high construction To be used only with a complete cable gland	MZFOS 15 L25 CZFOS 15 L21	MZFVS 15 L25 CZFVS 15 L21	M25 Pg 21	
	Cover, 2 pegs and gasket For enclosures with 1 lever without gasket with eyelet for housings		With eyelet CZCS 15 L		


Inserts size 49.16		Poles	Pages
CDA	16 A	10 + ⊕	B.16
CDC	16 A	10 + ⊕	B.19
CSAH	16 A	10 + ⊕	B.24
CD	10 A	15 + ⊕	B.30

MIXO Modular Inserts		Pages
MIXO modules		C.12-93
CX 01 T (1-slot sized MIXO frames)		C.94

Slim enclosures – EMC series

size **66.16**


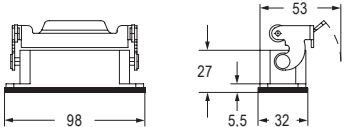

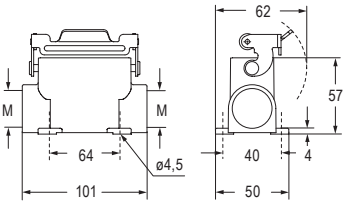


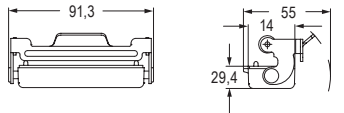
Housings and covers – 1 lever

Specialized Applications 

EN 60529	IP65 / IP66 / IP67 / IP69
UL 50 / UL 50E	Type 12 / 4 / 4X
Ambient temperature limits	-40 °C ... +125 °C
Mechanical life (cycles)	≥ 500



CAUS ECBT2.E115072 | ECBT8.E115072

Item	Description	Part No.	Entry	Dimension
	Bulkhead mounting housings, 1 lever, without gasket	CZ7IS 25 L		
	Surface mounting housings, 1 lever, without gasket	MZ7PS 25L225 CZ7PS 25 L2	M25 × 2 Pg 16 × 2	
	Cover, 1 lever, without gasket For enclosures with 2 pegs and gasket with loop for hoods 	CZ7CS 25 LG		


EMC
E

Inserts size 66.16	Poles	Pages
CDA 16 A	16 + ⊕	B.17
CDC 16 A	16 + ⊕	B.20
CSAH 16 A	16 + ⊕	B.25
CD 10 A	25 + ⊕	B.31
CDD 10 A	38 + ⊕	B.33

Slim enclosures – EMC series

size **66.16**

Hoods and covers – 2 pegs


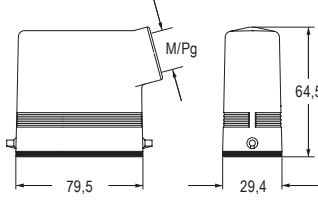

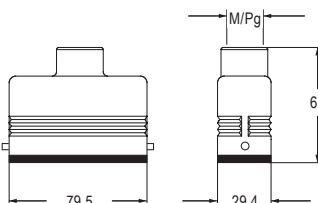

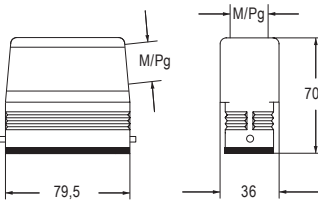

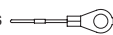
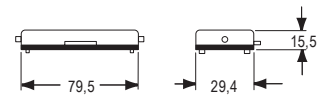
Specialized Applications 

CE UK



EN 60529	IP65 / IP66 / IP67 / IP69
UL 50 / UL 50E	Type 12 / 4 / 4X
Ambient temperature limits	-40 °C ... +125 °C
Mechanical life (cycles)	≥ 500

CULUS® ECBT2.E115072 | ECBT8.E115072

Item	Description	Side entry	Top entry	Entry	Dimension
	Hoods, 2 pegs and gasket, side entry	MZOS 25 L20 MZOS 25 L25 CZOS 25 L		M20 M25 Pg 16	
	Hoods, 2 pegs and gasket, top entry To be used only with a complete cable gland		MZVS 25 L20 CZVS 25 L	M20 Pg 16	
	Hoods, 2 pegs and gasket, side or top entry, high construction To be used only with a complete cable gland	MZFOS 25 L25 CZFOS 25 L21	MZFVS 25 L25 CZFVS 25 L21	M25 Pg 21	
	Cover, 2 pegs and gasket For enclosures with 1 lever without gasket with eyelet for housings 		With eyelet CZCS 25 L		

Inserts size 66.16	Poles	Pages
CDA 16 A	16 + ⊕	B.17
CDC 16 A	16 + ⊕	B.20
CSAH 16 A	16 + ⊕	B.25
CD 10 A	25 + ⊕	B.31
CDD 10 A	38 + ⊕	B.33

Panel cut-out drawings

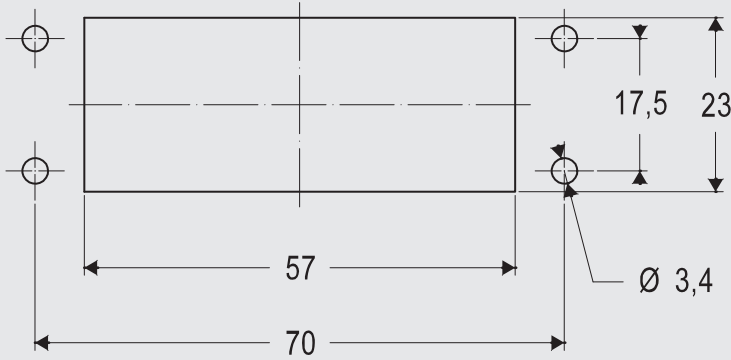
For SLIM series bulkhead mounting housings

To guarantee the declared IP degree of protection of the housings reported in this catalogue, according to EN IEC 60529 or to the relevant Type rating per ANSI/UL 50 and 50E (for those products bearing approval to those ratings), the surface of the mounting panel must meet the following requirements (definitions are provided in ISO 4287 standard):

Waviness $Wt \leq 0,2$ mm over a distance of 200 mm (measured on the panel without load)
Roughness $Ra \leq 16$ μ m

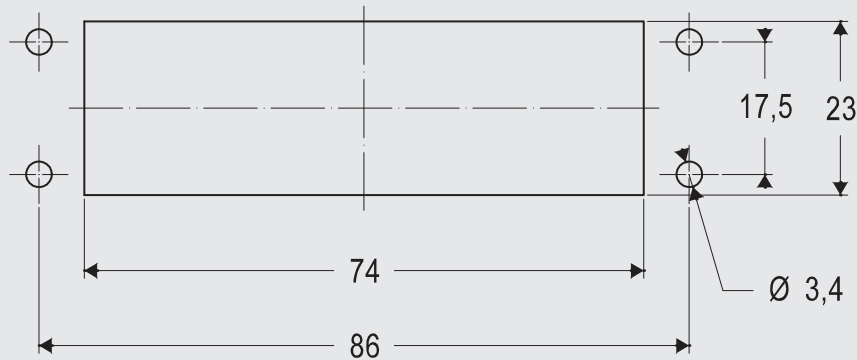
Scale 1:1

Size 49.16



Required screws: 4
Screws size: M3
Recommended torque:
 0,8 – 1,0 Nm / 7.1 – 8.9 lb.in

Size 66.16



Required screws: 4
Screws size: M3
Recommended torque:
 0,8 – 1,0 Nm / 7.1 – 8.9 lb.in

Note: The values of tightening torque indicated above are just recommended values, that must be related – by the designer of the final application – to the resistance class of the screws (not included), with the assumption that the mounting panel is sufficiently rigid (stiff). If the deflection of the panel, under the effect of tightening the screws, is greater than 0,7 mm over a distance of 100 mm, it is

necessary to use the counter-flanges mentioned in our catalogue or the special flange gaskets available upon request (please contact our Sales Department).

Panel cut-out drawings

For SLIM series bulkhead mounting housings

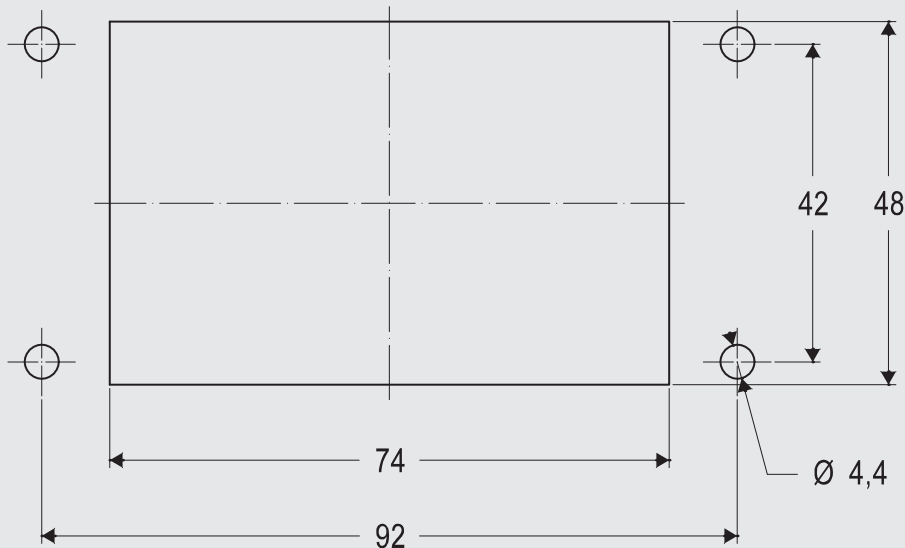
To guarantee the declared IP degree of protection of the housings reported in this catalogue, according to EN IEC 60529 or to the relevant Type rating per ANSI/UL 50 and 50E (for those products bearing approval to those ratings), the surface of the mounting panel must meet the following requirements (definitions are provided in ISO 4287 standard):

Waviness $W_t \leq 0,2$ mm over a distance of 200 mm
(measured on the panel without load)

Roughness $R_a \leq 16$ μm

Scale 1:1

Size 66.40



Required screws: 4
Screws size: M4
Recommended torque:
1,2 – 1,8 Nm / 10.6 – 15.9 lb.in

Note: The values of tightening torque indicated above are just recommended values, that must be related – by the designer of the final application – to the resistance class of the screws (not included), with the assumption that the mounting panel is sufficiently rigid (stiff). If the deflection of the panel, under the effect of tightening the screws, is greater than 0,7 mm over a distance of 100 mm, it is

necessary to use the counter-flanges mentioned in our catalogue or the special flange gaskets available upon request (please contact our Sales Department).



Heavy-Duty
Applications

C-TYPE

The classic choice



C-TYPE

Standard enclosures with C-TYPE levers

The iconic C-TYPE Class series has been developed for use in electrical and electronic machinery, control units, electrical panels, control equipment, industrial environments, and anywhere else a reliable and easily disconnectable connection is required for power and signal circuits.

E



Watch our clip

SUM-UP

CH – MH series

- > Made of die cast aluminium alloy
- > Gaskets in anti-aging, oil-resistant, grease-resistant and fuel resistant vinyl nitrile elastomer
- > Locking device with self-extinguishing thermoplastic handles, springs and pins in stainless-steel
- > Ambient temperature range: -40 °C / +125 °C

≡ Markings and Approvals

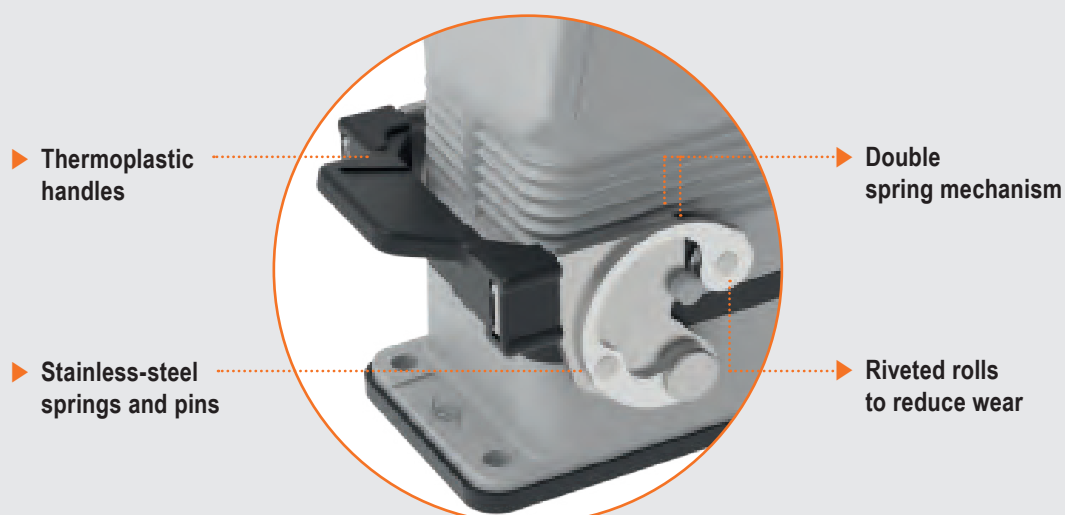
- CE and UK markings, EAC not applicable
- UL certified for USA and Canada for Type 12, 4 and 4X degrees of protection (enclosure type ratings, equivalent to NEMA rating)
- IP65 / IP66 / IP69 degree of protection
- RoHS: compliant

FOCUS

Levers and technology

The C-TYPE lever is a stainless steel lever with thermoplastic handles, designed to reduce the wear of the pegs on the hoods significantly, thanks to the presence of riveted rolls on a double spring mechanism.


The C-TYPE locking system provides smooth closure, resilience and compensation for any coupling tolerance.



C-TYPE series

Housings and hoods – 1 lever – with gasket

size **44.27**


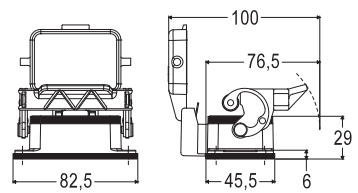

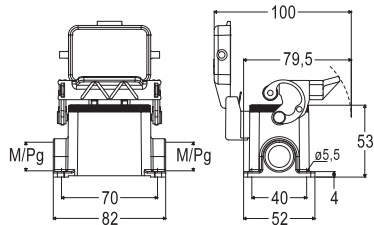

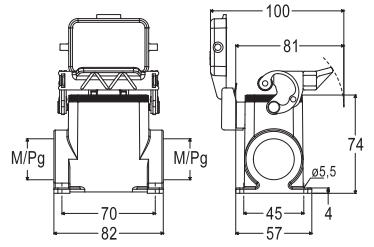

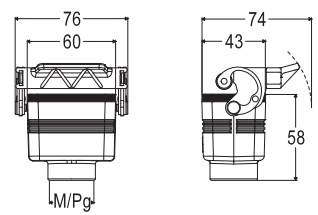

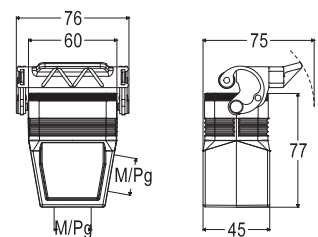
Heavy-Duty Applications 

CE UK CA



EN 60529	IP65 / IP66 / IP69
UL 50 / UL 50E	Type 12 / 4 / 4X
Ambient temperature limits	-40 °C ... +125 °C
Mechanical life (cycles)	≥ 500

CEBUS ECBT2.E115072 | ECBT8.E115072

Item	Description	Part No.	With cover	Entry	Dimension
	Bulkhead mounting housings, 1 lever and gasket, with or without metal cover	CHI 06 L	CHI 06 LS		
	Surface mounting housings, 1 lever and gasket, with or without metal cover	MHP 06 L20 MHP 06 L220 CHP 06 L CHP 06 L2	MHP 06 LS20 MHP 06 LS220 CHP 06 LS CHP 06 LS2	M20 M20 × 2 Pg 16 Pg 16 × 2	
	Surface mounting housings, 1 lever and gasket, with or without metal cover, high construction To be used only with a complete cable gland	MAP 06 L25 MAP 06 L225 MAP 06 L32 MAP 06 L232 MAP 06 L40 MAP 06 L240 CAP 06 L CAP 06 L2 CAP 06 L29 CAP 06 L229	MAP 06 LS32 MAP 06 LS232 MAP 06 LS40 MAP 06 LS240 CAP 06 LS CAP 06 LS2 CAP 06 LS29 CAP 06 LS229	M25 M25 × 2 M32 M32 × 2 M40 M40 × 2 Pg 21 Pg 21 × 2 Pg 29 Pg 29 × 2	
	Hoods, 1 lever and gasket, top entry		Top entry MHV 06 LG25 CHV 06 LG	M25 Pg 16	
	Hoods, 1 lever and gasket, side or top entry, high construction To be used only with a complete cable gland	Side entry MFO 06 LG40	Top entry MFV 06 LG25 MFV 06 LG32 MFV 06 LG40 CFV 06 LG21 CFV 06 LG29	M25 M32 M40 Pg 21 Pg 29	

Inserts size 44.27	Poles	Pages
CNE 16 A	6 + ⊕	3.38
CCE 16 A	6 + ⊕	3.44
CSH / JSH S	16 A	3.52 58
CQE / CQEY	16 A	3.72 82
CDD 10 A	24 + ⊕	3.94
CDSH / CDSH NC 10 A	9 and 6 + ⊕	3.102 108
CSS 16 A	6 + ⊕	3.116
CT / CTSE*	16 A	3.126 130

MIXO Modular Inserts	Pages
MIXO modules	C.12-93
CX 02 T (2-slot sized MIXO frames)	C.95

Accessories:

 **CHCP 06**
Dust protection cover
Page [6.46](#)

*can be used only in bulkhead mounting housings

C-TYPE

E


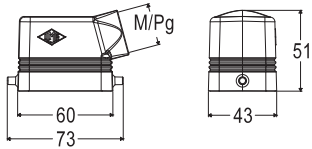

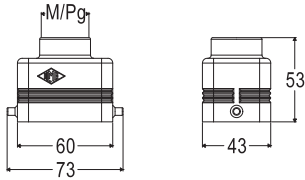

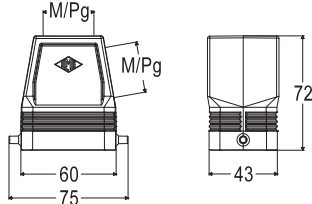

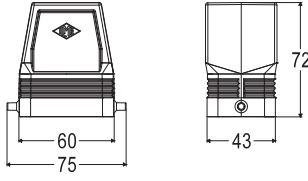
C-TYPE series

Hoods - 2 pegs - without gasket

size **44.27**
Heavy-Duty Applications
CE UK


EN 60529	IP65 / IP66 / IP69
UL 50 / UL 50E	Type 12 / 4 / 4X
Ambient temperature limits	-40 °C ... +125 °C
Mechanical life (cycles)	≥ 500

CALUS ECBT2.E115072 | ECBT8.E115072

Item	Description	Side entry	Top entry	Entry	Dimension
	Hoods, 2 pegs, without gasket, side entry	MHO 06 L20 MHO 06 L25 CHO 06 L13 CHO 06 L16		M20 M25 Pg 13,5 Pg 16	
	Hoods, 2 pegs, without gasket, top entry To be used only with a complete cable gland		MHV 06 L20 MHV 06 L25 CHV 06 L13 CHV 06 L16	M20 M25 Pg 13,5 Pg 16	
	Hoods, 2 pegs, without gasket, side or top entry, high construction To be used only with a complete cable gland	MFO 06 L25 MFO 06 L32 MFO 06 L40 CFO 06 L21 CFO 06 L29	MFV 06 L25 MFV 06 L32 MFV 06 L40 CFV 06 L21 CFV 06 L29	M25 M32 M40 Pg 21 Pg 29	
	Hoods, 2 pegs, without gasket, high construction, designed to be drilled	Without entry CAC 06 L			

Inserts size 44.27	Poles	Pages	MIXO Modular Inserts	Pages
CNE	16 A	6 + ⊕	B.38	C.12-93
CCE	16 A	6 + ⊕	B.44	C.95
CSH / JSH S	16 A	6 + ⊕	B.52,58	
CQE / CQEY	16 A	10 + ⊕	B.72,82	
CDD	10 A	24 + ⊕	B.94	
CDSH / CDSH NC	10 A	9 and 6 + ⊕	B.102,108	
CSS	16 A	6 + ⊕	B.118	


Accessories:

CHCP 06
Dust protection cover
Page G.46

C-TYPE series

Housings – 2 pegs – with gasket

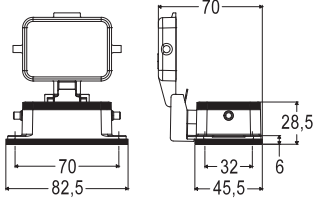
size **44.27**

Heavy-Duty Applications 

EN 60529	IP65 / IP66 / IP69
UL 50 / UL 50E	Type 12 / 4 / 4X
Ambient temperature limits	-40 °C ... +125 °C
Mechanical life (cycles)	≥ 500



CEBUS® ECBT2.E115072 | ECBT8.E115072

Item	Description	Part No.	With cover	Entry	Dimension
	Bulkhead mounting housings, 2 pegs and gasket, with or without metal cover	CHI 06 LC	CHI 06 LCS		
	Bulkhead mounting housings, 2 pegs and gasket, with or without plastic cover Enclosures with plastic cover do not have UL approval		CHI 06 LCP		

C-TYPE

E

Inserts size 44.27	Poles	Pages	MIXO Modular Inserts	Pages
CNE	16 A 6 + ⊕	B.38	MIXO modules	C.12-93
CCE	16 A 6 + ⊕	B.44	CX 02 T (2-slot sized MIXO frames)	C.95
CSH / JSH S	16 A 6 + ⊕	B.52,58		
CQE / CQEY	16 A 10 + ⊕	B.72,82		
CDD	10 A 24 + ⊕	B.94		
CDSH / CDSH NC	10 A 9 and 6 + ⊕	B.102,108		
CSS	16 A 6 + ⊕	B.118		
CT / CTSE*	16 A 6 + ⊕	B.126,130		

*can be used only in bulkhead mounting housings

Accessories:

 **CHCP 06**
Dust protection cover
Page G.46

C-TYPE series

Hoods - 1 lever - without gasket

 size **44.27**


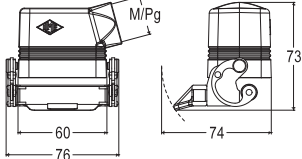

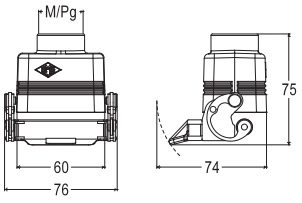
Heavy-Duty Applications

EN 60529	IP66 / IP69
UL 50 / UL 50E	Type 12 / 4 / 4X
Ambient temperature limits	-40 °C ... +125 °C
Mechanical life (cycles)	≥ 500



CE UK CA

 C[®]ALUS ECBT2.E115072 | ECBT8.E115072

Item	Description	Side entry	Top entry	Entry	Dimension
	Hoods, 1 lever, without gasket, side entry	MHO 06 LX20 MHO 06 LX25 CHO 06 LX16		M20 M25 Pg 16	
	Hoods, 1 lever, without gasket, top entry To be used only with a complete cable gland		MHV 06 LX20 MHV 06 LX25 CHV 06 LX16	M20 M25 Pg 16	

Inserts size 44.27	Poles	Pages	MIXO Modular Inserts	Pages	
CNE	16 A	6 + ⊕	B.38	MIXO modules	C.12-93
CCE	16 A	6 + ⊕	B.44	CX 02 T (2-slot sized MIXO frames)	C.95
CSH / JSH S	16 A	6 + ⊕	B.52,58		
CQE / CQEY	16 A	10 + ⊕	B.72,82		
CDD	10 A	24 + ⊕	B.94		
CDSH / CDSH NC	10 A	9 and 6 + ⊕	B.102,108		
CSS	16 A	6 + ⊕	B.118		

Accessories:

CHCP 06
Dust protection cover
Page G.46

C-TYPE series

Covers


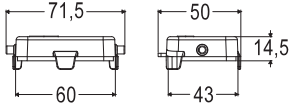



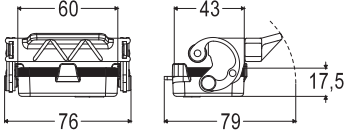
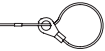

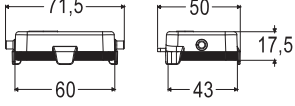
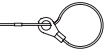
size **44.27**

Heavy-Duty Applications 

EN 60529	IP66 / IP69
UL 50 / UL 50E	Type 12 / 4 / 4X
Ambient temperature limits	-40 °C ... +125 °C
Mechanical life (cycles)	≥ 500



CAIUS ECBT2.E115072 | ECBT8.E115072

Item	Description	With loop	With eyelet	Entry	Dimension
	Covers, 2 pegs, without gasket	CHC 06 SL	CHC 06 L		
	For enclosures with 1 lever and gasket with loop for hoods  or with eyelet for housings 				
	Covers, 1 lever and gasket	CHC 06 LG			
	For enclosures with 2 pegs without gasket with loop for hoods 				
	Covers, 2 pegs and gasket	CHC 06 LC			
	For enclosures with 1 lever without gasket with loop for hoods 				

C-TYPE

E

C-TYPE series

Special enclosures

size **44.27**
Heavy-Duty Applications
CE UK


EN 60529	IP65 / IP66 / IP69
UL 50 / UL 50E	Type 12 / 4 / 4X
Ambient temperature limits	-40 °C ... +125 °C
Mechanical life (cycles)	≥ 500

CAUS ECBT2.E115072 | ECBT8.E115072

Item	Description	Part No.	Entry	Dimension
	Angled surface mounting housings, 1 lever and gasket, cable gland entry, closed bulkhead - versions with M32, Pg 21 or Pg 29 entry on request. To be used only with a complete cable gland	MAV 06LG25-F	M25	

Inserts size 44.27	Poles	Pages	MIXO Modular Inserts	Pages
CNE 16 A	6 + ⊕	B.38	MIXO modules	C.12-93
CCE 16 A	6 + ⊕	B.44	CX 02 T (2-slot sized MIXO frames)	C.95
CSH / JSH S	16 A	6 + ⊕		B.52,58
CQE / CQEY	16 A	10 + ⊕		B.72,82
CDD	10 A	24 + ⊕		B.94
CDSH / CDSH NC	10 A	9 and 6 + ⊕		B.102,108
CSS	16 A	6 + ⊕		B.118

Accessories:

CHCP 06
 Dust protection cover
 Page G.46

C-TYPE series

Housings and hoods – 1 lever – with gasket


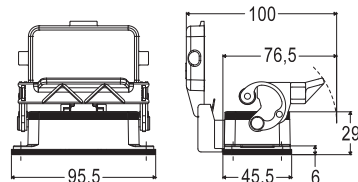

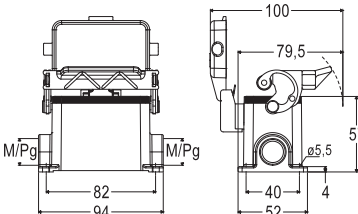

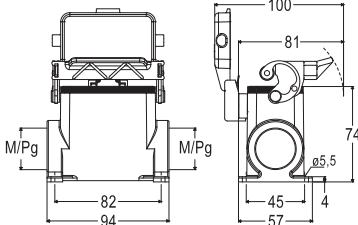

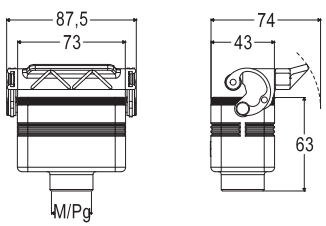

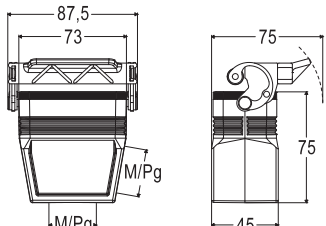
size **57.27**

Heavy-Duty Applications



CAUS ECBT2.E115072 | ECBT8.E115072

EN 60529	IP65 / IP66 / IP69
UL 50 / UL 50E	Type 12 / 4 / 4X
Ambient temperature limits	-40 °C ... +125 °C
Mechanical life (cycles)	≥ 500

Item	Description	Part No.	With cover	Entry	Dimension
	Bulkhead mounting housings, 1 lever and gasket, with or without metal cover	CHI 10 L	CHI 10 LS		
	Surface mounting housings, 1 lever and gasket, with or without metal cover	MHP 10 L20 MHP 10 L220 CHP 10 L CHP 10 L2	MHP 10 LS20 MHP 10 LS220 CHP 10 LS CHP 10 LS2	M20 M20 × 2 Pg 16 Pg 16 × 2	
	Surface mounting housings, 1 lever and gasket, with or without metal cover, high construction	MAP 10 L32 MAP 10 L232 MAP 10 L40 MAP 10 L240 CAP 10 L CAP 10 L2 CAP 10 L29 CAP 10 L229	MAP 10 LS32 MAP 10 LS232 MAP 10 LS40 MAP 10 LS240 CAP 10 LS CAP 10 LS2 CAP 10 LS29 CAP 10 LS229	M32 M32 × 2 M40 M40 × 2 Pg 21 Pg 21 × 2 Pg 29 Pg 29 × 2	
	Hoods, 1 lever and gasket, top entry		Top entry MHV 10 LG25 CHV 10 LG	M25 Pg 16	
	Hoods, 1 lever and gasket, side or top entry, high construction To be used only with a complete cable gland	MFO 10 LG40	Side entry Top entry MFV 10 LG25 MFV 10 LG32 CFV 10 LG21 CFV 10 LG29	M25 M32 M40 Pg 21 Pg 29	

Inserts size 57.27	Poles	Pages	Inserts size 57.27	Poles	Pages		
CNE	16 A	10 + ⊕	B.39	CT / CTSE*	16 A	10 + ⊕	B.127,131
CCE	16 A	10 + ⊕	B.45	CMCE / CMSH	16 A	3 + 2 (aux.) + ⊕	B.144,149
CSH / JSH S	16 A	10 + ⊕	B.53,59	CX	40 A/10 A	8/24 + ⊕	B.170-171
CSHT	16 A	10 + ⊕	B.66	*can be used only in bulkhead mounting housings			
CQE / CQEY	16 A	18 + ⊕	B.73,83	MIXO Modular Inserts			
CDD	10 A	42 + ⊕	B.95	MIXO modules		C.12-93	
CDSH	10 A	18 + ⊕	B.103	CX 03 T (3-slot sized MIXO frames)		C.95	
CSS	16 A	10 + ⊕	B.119				


Accessories:



CHCP 10
Dust protection cover
Page G.46

C-TYPE series


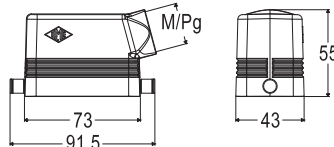

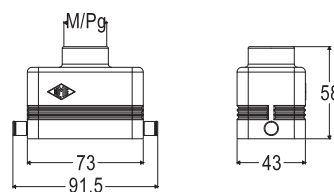

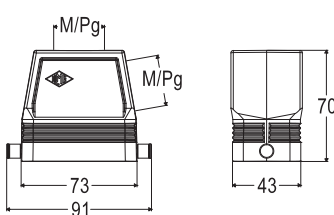

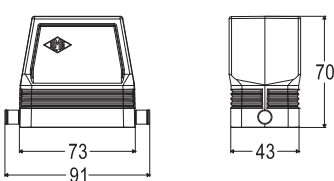
Hoods - 2 pegs - without gasket

size **57.27**
Heavy-Duty Applications




EN 60529	IP65 / IP66 / IP69
UL 50 / UL 50E	Type 12 / 4 / 4X
Ambient temperature limits	-40 °C ... +125 °C
Mechanical life (cycles)	≥ 500

 ECBT2.E115072 | ECBT8.E115072

Item	Description	Side entry	Top entry	Entry	Dimension
	Hoods, 2 pegs, without gasket, side entry	MHO 10 L20 MHO 10 L25 CHO 10 L16		M20 M25 Pg 16	
	Hoods, 2 pegs, without gasket, top entry To be used only with a complete cable gland		MHV 10 L20 MHV 10 L25 CHV 10 L	M20 M25 Pg 16	
	Hoods, 2 pegs, without gasket, side or top entry, high construction To be used only with a complete cable gland	MFO 10 L32 MFO 10 L40 CFO 10 L21 CFO 10 L29	MFV 10 L32 MFV 10 L40 CFV 10 L21 CFV 10 L29	M32 M40 Pg 21 Pg 29	
	Hoods, 2 pegs, without gasket, high construction, designed to be drilled	Without entry CAC 10 L			

C-TYPE

E

Inserts size 57.27	Poles	Pages	Inserts size 57.27	Poles	Pages		
CNE	16 A	10 + ⊕	B.39	CMCE / CMSH	16 A	3 + 2 (aux.) + ⊕	B.144,149
CCE	16 A	10 + ⊕	B.45	CX	40 A/10 A	8/24 + ⊕	B.170-171
CSH / JSH S	16 A	10 + ⊕	B.53,59				
CSHT	16 A	10 + ⊕	B.66				
CQE / CQEY	16 A	18 + ⊕	B.73,83				
CDD	10 A	42 + ⊕	B.95	MIXO Modular Inserts		Pages	
CDSH	10 A	18 + ⊕	B.103	MIXO modules		C.12-93	
CSS	16 A	10 + ⊕	B.119	CX 03 T (3-slot sized MIXO frames)		C.95	

Accessories:

CHCP 10
Dust protection cover
Page G.46

C-TYPE series

Housings and hoods – 2 levers – with gasket

size **57.27**


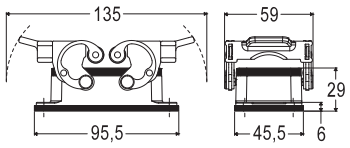

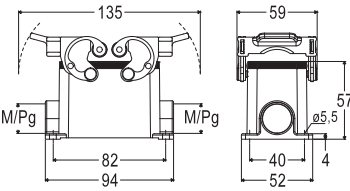

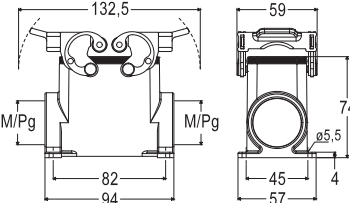

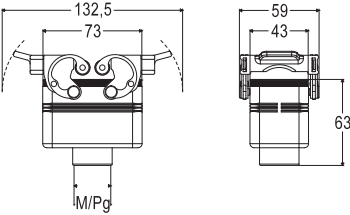

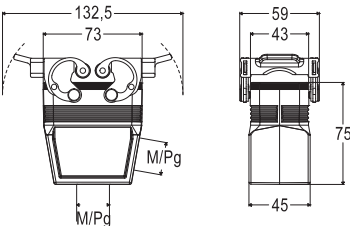
Heavy-Duty Applications 

CE UK

CEC DNV VERITAS


EN 60529	IP65 / IP66 / IP69
UL 50 / UL 50E	Type 12 / 4 / 4X
Ambient temperature limits	-40 °C ... +125 °C
Mechanical life (cycles)	≥ 500

CAIUS ECBT2.E115072 | ECBT8.E115072


Item	Description	Part No.	Entry	Dimension
	Bulkhead mounting housings, 2 levers and gasket	CHI 10		
	Surface mounting housings, 2 levers and gasket	MHP 10.20 MHP 10.220 CHP 10 CHP 10.2	M20 M20 × 2 Pg 16 Pg 16 × 2	
	Surface mounting housings, 2 levers and gasket, high construction To be used only with a complete cable gland	MAP 10.25 MAP 10.225 MAP 10.32 MAP 10.232 MAP 10.40 MAP 10.240 CAP 10.21 CAP 10.221 CAP 10.29 CAP 10.229	M25 M25 × 2 M32 M32 × 2 M40 M40 × 2 Pg 21 Pg 21 × 2 Pg 29 Pg 29 × 2	
	Hoods, 2 levers and gasket, top entry	Top entry MHV 10 G25 CHV 10 G	M25 Pg 16	
	Hoods, 2 levers and gasket, side or top entry, high construction To be used only with a complete cable gland	Side entry Top entry MFV 10 G25 MFV 10 G32 MFV 10 G40 CFV 10 G CFV 10 G29	M25 M32 M40 Pg 21 Pg 29	

Inserts size 57.27	Poles	Pages	Inserts size 57.27	Poles	Pages
CNE	16 A	10 + ☉	CT / CTSE*	16 A	10 + ☉
CCE	16 A	10 + ☉	CMCE / CMSH	16 A	3 + 2 (aux.) + ☉
CSH / JSH S	16 A	10 + ☉	CX	40 A/10 A	8/24 + ☉
CSHT	16 A	10 + ☉	*can be used only in bulkhead mounting housings		
CQE / CQEY	16 A	18 + ☉	MIXO Modular Inserts		
CDD	10 A	42 + ☉	MIXO modules		
CDSH	10 A	18 + ☉	MIXO 03 T (3-slot sized MIXO frames)		
CSS	16 A	10 + ☉			

Accessories:



CHCP 10
Dust protection cover
Page [G.46](#)




CR LCK
Locking device
Page [G.43](#)

C-TYPE E


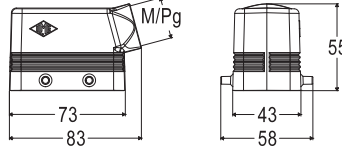

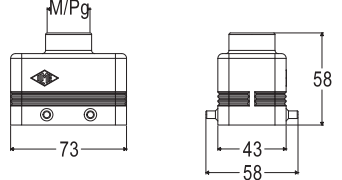

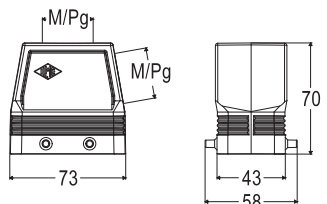

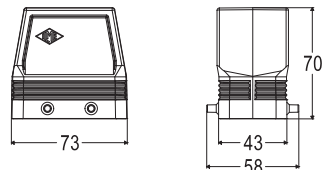
C-TYPE series

Hoods - 4 pegs - without gasket

size **57.27**
Heavy-Duty Applications



EN 60529	IP65 / IP66 / IP69
UL 50 / UL 50E	Type 12 / 4 / 4X
Ambient temperature limits	-40 °C ... +125 °C
Mechanical life (cycles)	≥ 500


 ECBT2.E115072 | ECBT8.E115072

Item	Description	Side entry	Top entry	Entry	Dimension
	Hoods, 4 pegs, without gasket, side entry	MHO 10.20 MHO 10.25 CHO 10		M20 M25 Pg 16	
	Hoods, 4 pegs, without gasket, top entry To be used only with a complete cable gland		MHV 10.20 MHV 10.25 CHV 10	M20 M25 Pg 16	
	Hoods, 4 pegs, without gasket, side or top entry, high construction To be used only with a complete cable gland	MFO 10.32 MFO 10.40 CFO 10.21 CFO 10.29	MFV 10.32 MFV 10.40 CFV 10.21 CFV 10.29	M32 M40 Pg 21 Pg 29	
	Hoods, 4 pegs, without gasket, high construction, designed to be drilled	Without entry CAC 10			

C-TYPE

E

Inserts size 57.27	Poles	Pages	Inserts size 57.27	Poles	Pages		
CNE	16 A	10 + ⊕	B.39	CMCE / CMSH	16 A	3 + 2 (aux.) + ⊕	B.144,149
CCE	16 A	10 + ⊕	B.45	CX	40 A/10 A	8/24 + ⊕	B.170-171
CSH / JSH S	16 A	10 + ⊕	B.53,59				
CSHT	16 A	10 + ⊕	B.66				
CQE / CQEY	16 A	18 + ⊕	B.73,83				
CDD	10 A	42 + ⊕	B.95	MIXO Modular Inserts		Pages	
CDSH	10 A	18 + ⊕	B.103	MIXO modules		C.12-93	
CSS	16 A	10 + ⊕	B.119	CX 03 T (3-slot sized MIXO frames)		C.95	


Accessories:

CHCP 10
Dust protection cover
Page G.46

C-TYPE series

Housings – 4 pegs – with gasket

size **57.27**


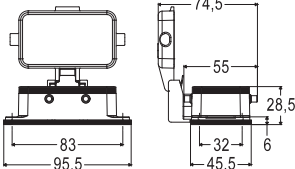

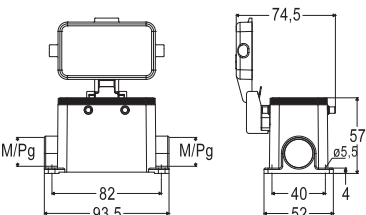

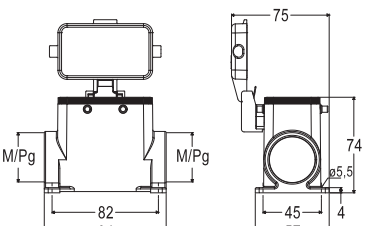
Heavy-Duty Applications 

CE UK

CEC DNV SIFITA

EN 60529	IP65 / IP66 / IP69
UL 50 / UL 50E	Type 12 / 4 / 4X
Ambient temperature limits	-40 °C ... +125 °C
Mechanical life (cycles)	≥ 500

CAUS ECBT2.E115072 | ECBT8.E115072

Item	Description	Metal cover	Plastic cover	Entry	Dimension
	Bulkhead mounting housings, 4 pegs and gasket, with or without metal or plastic cover	CHI 10 CS	CHI 10 CP		
	Enclosures with plastic cover do not have UL approval	Without Cover	CHI 10 C		
	Surface mounting housings, 4 pegs and gasket, with metal or plastic cover	MHP 10 CS20 MHP 10 CS220 CHP 10 CS CHP 10 CS2	MHP 10 CP20 MHP 10 CP220 CHP 10 CP CHP 10 CP2	M20 M20 × 2 Pg 16 Pg 16 × 2	
	Enclosures with plastic cover do not have UL approval				
	Surface mounting housings, 4 pegs and gasket, with metal or plastic cover, high construction	MAP 10 CS32 MAP 10 CS232 MAP 10 CS40 MAP 10 CS240 CAP 10 CS CAP 10 CS2 CAP 10 CS29 CAP 10 CS229	MAP 10 CP32 MAP 10 CP232 MAP 10 CP40 MAP 10 CP240 CAP 10 CP CAP 10 CP2 CAP 10 CP29 CAP 10 CP229	M32 M32 × 2 M40 M40 × 2 Pg 21 Pg 21 × 2 Pg 29 Pg 29 × 2	
	Enclosures with plastic cover do not have UL approval				

C-TYPE

E

Inserts size 57.27	Poles	Pages	Inserts size 57.27	Poles	Pages		
CNE	16 A	10 + ⊕	B.39	CT / CTSE*	16 A	10 + ⊕	B.127,131
CCE	16 A	10 + ⊕	B.45	CMCE / CMSH	16 A	3 + 2 (aux.) + ⊕	B.144,149
CSH / JSH S	16 A	10 + ⊕	B.53,59	CX	40 A/10 A	8/24 + ⊕	B.170-171
CSHT	16 A	10 + ⊕	B.66	*can be used only in bulkhead mounting housings			
CQE / CQEY	16 A	18 + ⊕	B.73,83	MIXO Modular Inserts			
CDD	10 A	42 + ⊕	B.95	MIXO modules	Pages		
CDSH	10 A	18 + ⊕	B.103	CX 03 T (3-slot sized MIXO frames)	C.12-93		
CSS	16 A	10 + ⊕	B.119		C.95		

Accessories:



CHCP 10
Dust protection cover
Page G.46

C-TYPE series


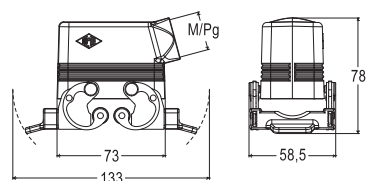

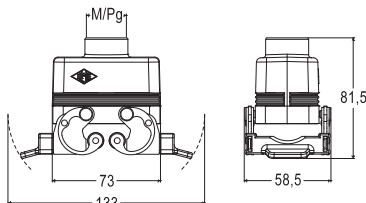

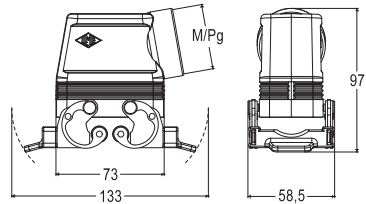

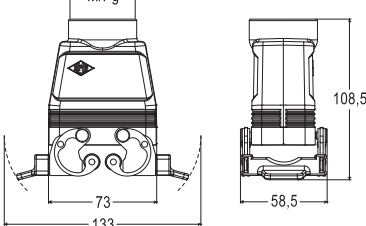
Hoods - 2 levers - without gasket

size **57.27**
Heavy-Duty Applications




EN 60529	IP65 / IP66 / IP69
UL 50 / UL 50E	Type 12 / 4 / 4X
Ambient temperature limits	-40 °C ... +125 °C
Mechanical life (cycles)	≥ 500

 ECBT2.E115072 | ECBT8.E115072

Item	Description	Side entry	Top entry	Entry	Dimension
	Hoods, 2 levers, without gasket, side entry	MHO 10 X20 MHO 10 X25 CHO 10 X		M20 M25 Pg 16	
	Hoods, 2 levers, without gasket, top entry To be used only with a complete cable gland		MHV 10 X20 MHV 10 X25 CHV 10 X	M20 M25 Pg 16	
	Hoods, 2 levers, without gasket, side entry, high construction	MAO 10 X32 MAO 10 X40 CAO 10 X CAO 10 X29		M32 M40 Pg 21 Pg 29	
	Hoods, 2 levers, without gasket, top entry, high construction		MAV 10 X32 MAV 10 X40 CAV 10 X CAV 10 X29	M32 M40 Pg 21 Pg 29	

C-TYPE

E

Inserts size 57.27	Poles	Pages	Inserts size 57.27	Poles	Pages
CNE	16 A	10 + ⊕ B.39	CMCE / CMSH	16 A	3 + 2 (aux.) + ⊕ B.144,149
CCE	16 A	10 + ⊕ B.45	CX	40 A/10 A	8/24 + ⊕ B.170-171
CSH / JSH S	16 A	10 + ⊕ B.53,59			
CSHT	16 A	10 + ⊕ B.66			
CQE / CQEY	16 A	18 + ⊕ B.73,83			
CDD	10 A	42 + ⊕ B.95	MIXO Modular Inserts		Pages
CDSH	10 A	18 + ⊕ B.103	MIXO modules		C.12-93
CSS	16 A	10 + ⊕ B.119	CX 03 T (3-slot sized MIXO frames)		C.95

Accessories:

CHCP 10
Dust protection cover
Page G.46

C-TYPE series

Covers

size **57.27**




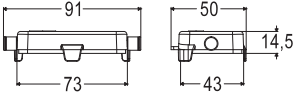



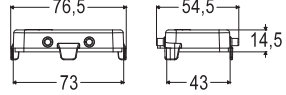


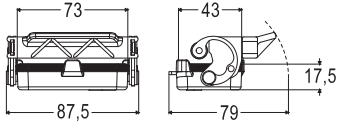


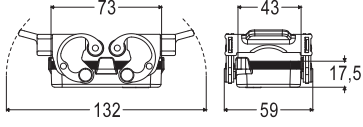


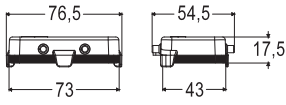
Heavy-Duty Applications 

CE UK CA

CEC DNV SIFITA

EN 60529	IP65 / IP66 / IP69
UL 50 / UL 50E	Type 12 / 4 / 4X
Ambient temperature limits	-40 °C ... +125 °C
Mechanical life (cycles)	≥ 500

CAIUS® ECBT2.E115072 | ECBT8.E115072

Item	Description	With loop	With eyelet	Entry	Dimension
	Covers, 2 pegs, without gasket For enclosures with 1 lever and gasket with loop for hoods  or with eyelet for housings 	CHC 10 SL	CHC 10 L		
	Covers, 4 pegs, without gasket For enclosures with 2 levers and gasket with loop for hoods  or with eyelet for housings 	CHC 10 S	CHC 10		
	Covers, 1 lever and gasket For enclosures with 2 pegs without gasket with loop for hoods 	CHC 10 LG			
	Covers, 2 levers and gasket For enclosures with 4 pegs without gasket with loop for hoods 	CHC 10 G			
	Covers, 4 pegs and gasket For enclosures with 2 levers without gasket with loop for hoods 	CHC 10 C			

C-TYPE

E

C-TYPE series

Special enclosures

size **57.27**
Heavy-Duty Applications

EN 60529	IP65 / IP66 / IP69
UL 50 / UL 50E	Type 12 / 4 / 4X
Ambient temperature limits	-40 °C ... +125 °C
Mechanical life (cycles)	≥ 500



ECBT2.E115072 | ECBT8.E115072

Item	Description	Part No.	Entry	Dimension
	Hoods, 4 pegs, without gasket, 2 top entries, high construction To be used only with complete cable glands	MFV 10.220 CFV 10.213	M20 × 2 Pg 13,5 × 2	
	Hoods, 4 pegs, without gasket, frontal entry, high construction To be used only with a complete cable gland	MFF 10.20 CFF 10	M20 Pg 16	


Inserts size 57.27	Poles	Pages	Inserts size 57.27	Poles	Pages		
CNE	16 A	10 + ⊕	B.39	CMCE / CMSH	16 A	3 + 2 (aux.) + ⊕	B.144,149
CCE	16 A	10 + ⊕	B.45	CX	40 A/10 A	8/24 + ⊕	B.170-171
CSH / JSH S	16 A	10 + ⊕	B.53,59				
CSHT	16 A	10 + ⊕	B.66				
CQE / CQEY	16 A	18 + ⊕	B.73,83				
CDD	10 A	42 + ⊕	B.95	MIXO Modular Inserts		Pages	
CDSH	10 A	18 + ⊕	B.103	MIXO modules		C.12-93	
CSS	16 A	10 + ⊕	B.119	CX 03 T (3-slot sized MIXO frames)		C.95	

Accessories:
CHCP 10
 Dust protection
 cover
 Page G.46

C-TYPE series

Housings and hoods – 1 lever – with gasket

size **77.27**


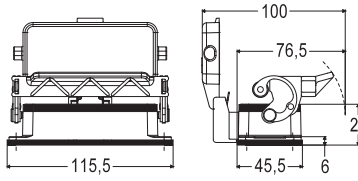

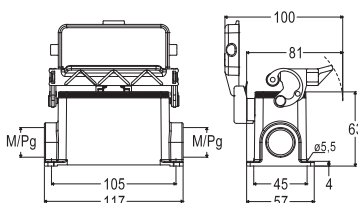

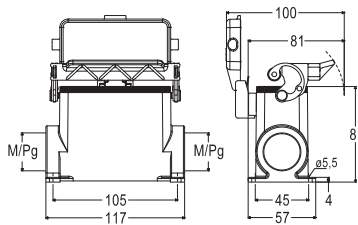

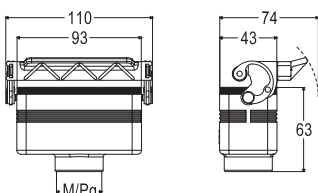

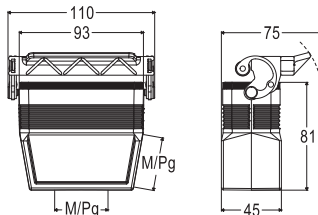
Heavy-Duty Applications 

CE UK CA

EN 60529	IP65 / IP66 / IP69
UL 50 / UL 50E	Type 12 / 4 / 4X
Ambient temperature limits	-40 °C ... +125 °C
Mechanical life (cycles)	≥ 500



CAUS ECBT2.E115072 | ECBT8.E115072

Item	Description	Part No.	With cover	Entry	Dimension
	Bulkhead mounting housings, 1 lever and gasket, with or without metal cover	CHI 16 L	CHI 16 LS		
	Surface mounting housings, 1 lever and gasket, with or without metal cover	MHP 16 L25 MHP 16 L225 CHP 16 L CHP 16 L2	MHP 16 LS25 MHP 16 LS225 CHP 16 LS CHP 16 LS2	M25 M25 × 2 Pg 21 Pg 21 × 2	
	Surface mounting housings, 1 lever and gasket, with or without metal cover, high construction	MAP 16 L32 MAP 16 L232 MAP 16 L40 MAP 16 L240 CAP 16 L CAP 16 L2 CAP 16 L29 CAP 16 L229	MAP 16 LS32 MAP 16 LS232 MAP 16 LS40 MAP 16 LS240 CAP 16 LS CAP 16 LS2 CAP 16 LS29 CAP 16 LS229	M32 M32 × 2 M40 M40 × 2 Pg 21 Pg 21 × 2 Pg 29 Pg 29 × 2	
	Hoods, 1 lever and gasket, top entry		Top entry MHV 16 LG32 CHV 16 LG	M32 Pg 21	
	Hoods, 1 lever and gasket, side or top entry, high construction To be used only with a complete cable gland	MFO 16 LG40	Side entry Top entry MFV 16 LG25 MFV 16 LG32 CFV 16 LG21 CFV 16 LG29	M25 M32 M40 Pg 21 Pg 29	

C-TYPE


E

Inserts size 77.27	Poles	Pages	Inserts size 77.27	Poles	Pages	MIXO Modular Inserts	Pages
CNE 16 A	16 + ⊕	B.40	CP / CPY 35 A	6 + ⊕	B.112-114	MIXO modules	C.12-93
CCE 16 A	16 + ⊕	B.46	CSS 16 A	16 + ⊕	B.120	CX 04 T (4-slot sized MIXO frames)	C.93
CSH / JSH S 16 A	16 + ⊕	B.54-60	CT / CTSE* 16 A	16 + ⊕	B.128-132		
CSHT 16 A	16 + ⊕	B.67	CT / CTS* 10 A	40 + ⊕	B.138-140		
CQE / CQEY 16 A	32 + ⊕	B.74-84	CMCE / CMSH 16 A	6 + 2 (aux.) + ⊕	B.145-150		
CQEE 16 A	40 + ⊕	B.78	CX / CXC 80 A/16 A	4/0, 4/2 + ⊕	B.158-160		
CD 10 A	40 + ⊕	B.90	CX 40 A/10 A	6/12, 6/36, 9/42 and 12/2 + ⊕	B.163-164 168-169		
CDD 10 A	72 + ⊕	B.94					
CDSH 10 A	27 + ⊕	B.104					

*can be used only in bulkhead mounting housings

Accessories:

CHCP 16
Dust protection cover
Page [E.46](#)



C-TYPE series

Hoods – 2 pegs – without gasket

size **77.27**
Heavy-Duty Applications


EN 60529	IP65 / IP66 / IP69
UL 50 / UL 50E	Type 12 / 4 / 4X
Ambient temperature limits	-40 °C ... +125 °C
Mechanical life (cycles)	≥ 500

ECBT2.E115072 | ECBT8.E115072

Item	Description	Side entry	Top entry	Entry	Dimension
	Hoods, 2 pegs, without gasket, side entry	MHO 16 L25 MHO 16 L32 CHO 16 L		M25 M32 Pg 21	
	Hoods, 2 pegs, without gasket, top entry To be used only with a complete cable gland		MHV 16 L25 MHV 16 L32 CHV 16 L	M25 M32 Pg 21	
	Hoods, 2 pegs, without gasket, side or top entry, high construction To be used only with a complete cable gland	MFO 16 L32 MFO 16 L40 CFO 16 L21 CFO 16 L29	MFV 16 L32 MFV 16 L40 CFV 16 L21 CFV 16 L29	M32 M40 Pg 21 Pg 29	
	Hoods, 2 pegs, without gasket, high construction, designed to be drilled	Without entry			

C-TYPE

E

Inserts size 77.27	Poles	Pages	Inserts size 77.27	Poles	Pages	MIXO Modular Inserts	Pages
CNE	16 A	16 + ☉ B.40	CP / CPY	35 A	6 + ☉ B.112,114	MIXO modules	C.12-93
CCE	16 A	16 + ☉ B.46	CSS	16 A	16 + ☉ B.120	CX 04 T (4-slot sized MIXO frames)	C.95
CSH / JSH S	16 A	16 + ☉ B.54,60	CMCE / CMSH	16 A	6 + 2 (aux.) + ☉ B.145,150		
CSHT	16 A	16 + ☉ B.67	CX / CXC	80 A/16 A	4/0, 4/2 + ☉ B.158-160		
CQE / CQEY	16 A	32 + ☉ B.74,84	CX	40 A/10 A	6/12, 6/36, 9/42 and 12/2 + ☉ B.163-164, 168-169		
CQEE	16 A	40 + ☉ B.78					
CD	10 A	40 + ☉ B.90					
CDD	10 A	72 + ☉ B.94					
CDSH	10 A	27 + ☉ B.104					


Accessories:

CHCP 16
Dust protection cover
Page G.46

C-TYPE series

Housings and hoods – 2 levers – with gasket

size **77.27**


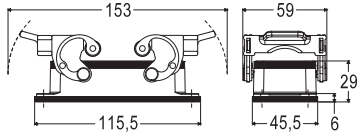

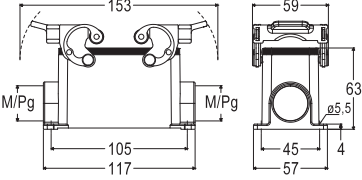

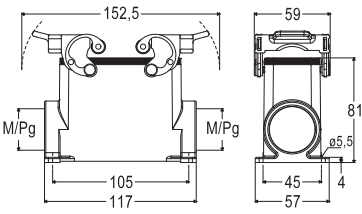

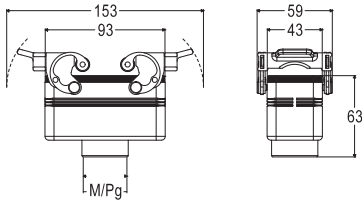

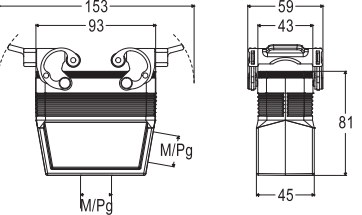
Heavy-Duty Applications 

CE UK CA

CEC DNV VERITAS

EN 60529	IP65 / IP66 / IP69
UL 50 / UL 50E	Type 12 / 4 / 4X
Ambient temperature limits	-40 °C ... +125 °C
Mechanical life (cycles)	≥ 500

CAUS ECBT2.E115072 | ECBT8.E115072

Item	Description	Part No.	Entry	Dimension
	Bulkhead mounting housings, 2 levers and gasket	CHI 16		
	Surface mounting housings, 2 levers and gasket	MHP 16.25 MHP 16.225 CHP 16 CHP 16.2	M25 M25 × 2 Pg 21 Pg 21 × 2	
	Surface mounting housings, 2 levers and gasket, high construction To be used only with a complete cable gland	MAP 16.25 MAP 16.225 MAP 16.32 MAP 16.232 MAP 16.40 MAP 16.240 CAP 16.21 CAP 16.221 CAP 16.29 CAP 16.229	M25 M25 × 2 M32 M32 × 2 M40 M40 × 2 Pg 21 Pg 21 × 2 Pg 29 Pg 29 × 2	
	Hoods, 2 levers and gasket, top entry	Top entry MHV 16 G32 CHV 16 G	M32 Pg 21	
	Hoods, 2 levers and gasket, side or top entry, high construction To be used only with a complete cable gland	Side entry Top entry MFV 16 G25 MFV 16 G32 MFV 16 G40 CFV 16 G CFV 16 G29	M25 M32 M40 Pg 21 Pg 29	

Inserts size 77.27	Poles	Pages	Inserts size 77.27	Poles	Pages	MIXO Modular Inserts	Pages
CNE 16 A	16 + ⊕	B.40	CP / CPY 35 A	6 + ⊕	B.112-114	MIXO modules	C.12-93
CCE 16 A	16 + ⊕	B.46	CSS 16 A	16 + ⊕	B.120	CX 04 T (4-slot sized MIXO frames)	C.93
CSH / JSH S 16 A	16 + ⊕	B.54-60	CT / CTSE* 16 A	16 + ⊕	B.128-132		
CSHT 16 A	16 + ⊕	B.67	CT / CTS* 10 A	40 + ⊕	B.138-140		
CQE / CQEY 16 A	32 + ⊕	B.74-84	CMCE / CMSH 16 A	6 + 2 (aux.) + ⊕	B.145-150		
CQEE 16 A	40 + ⊕	B.78	CX / CXC 80 A/16 A	4/0, 4/2 + ⊕	B.158-160		
CD 10 A	40 + ⊕	B.90	CX 40 A/10 A	6/12, 6/36, 9/42 and 12/2 + ⊕	B.163-164, 168-169		
CDD 10 A	72 + ⊕	B.94					
CDSH 10 A	27 + ⊕	B.104					

*can be used only in bulkhead mounting housings

Accessories:



CHCP 16
Dust protection cover
Page [G.46](#)



CR LCK
Locking device
Page [G.43](#)

C-TYPE series

Hoods - 4 pegs - without gasket

size **77.27**
Heavy-Duty Applications


EN 60529	IP65 / IP66 / IP69
UL 50 / UL 50E	Type 12 / 4 / 4X
Ambient temperature limits	-40 °C ... +125 °C
Mechanical life (cycles)	≥ 500

ECBT2.E115072 | ECBT8.E115072

Item	Description	Side entry	Top entry	Entry	Dimension
	Hoods, 4 pegs, without gasket, side entry	MHO 16.25 MHO 16.32 CHO 16		M25 M32 Pg 21	
	Hoods, 4 pegs, without gasket, top entry To be used only with a complete cable gland		MHV 16.25 MHV 16.32 CHV 16	M25 M32 Pg 21	
	Hoods, 4 pegs, without gasket, side or top entry, high construction To be used only with a complete cable gland	MFO 16.32 MFO 16.40 CFO 16.21 CFO 16.29	MFV 16.32 MFV 16.40 CFV 16.21 CFV 16.29	M32 M40 Pg 21 Pg 29	
	Hoods, 4 pegs, without gasket, high construction, designed to be drilled		Without entry CAC 16		

C-TYPE

E

Inserts size 77.27	Poles	Pages	Inserts size 77.27	Poles	Pages	MIXO Modular Inserts	Pages
CNE	16 A	16 + ☉ B.40	CP / CPY	35 A	6 + ☉ B.112,114	MIXO modules	C.12-93
CCE	16 A	16 + ☉ B.46	CSS	16 A	16 + ☉ B.120	CX 04 T (4-slot sized MIXO frames)	C.95
CSH / JSH S	16 A	16 + ☉ B.54,60	CMCE / CMSH	16 A	6 + 2 (aux.) + ☉ B.145,150		
CSHT	16 A	16 + ☉ B.67	CX / CXC	80 A/16 A	4/0, 4/2 + ☉ B.158-160		
CQE / CQEY	16 A	32 + ☉ B.74,84	CX	40 A/10 A	6/12, 6/36, 9/42 and 12/2 + ☉ B.163-164, 168-169		
CQEE	16 A	40 + ☉ B.78					
CD	10 A	40 + ☉ B.90					
CDD	10 A	72 + ☉ B.94					
CDSH	10 A	27 + ☉ B.104					


Accessories:

CHCP 16
Dust protection cover
Page G.46

C-TYPE series

Housings – 4 pegs – with gasket

size **77.27**


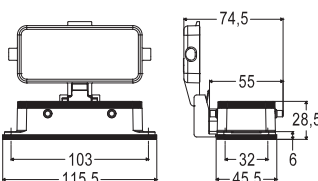

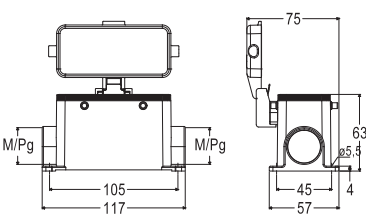

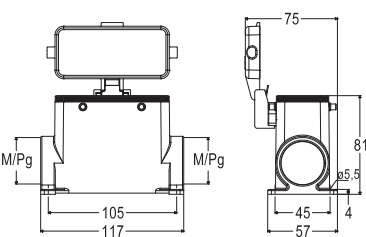
Heavy-Duty Applications 

CE UK CA

EN 60529	IP65 / IP66 / IP69
UL 50 / UL 50E	Type 12 / 4 / 4X
Ambient temperature limits	-40 °C ... +125 °C
Mechanical life (cycles)	≥ 500



CBUS ECBT2.E115072 | ECBT8.E115072

Item	Description	Metal cover	Plastic cover	Entry	Dimension
	Bulkhead mounting housings, 4 pegs and gasket, with or without metal or plastic cover Enclosures with plastic cover do not have UL approval	CHI 16 CS Without Cover CHI 16 C	CHI 16 CP		
	Surface mounting housings, 4 pegs and gasket, with metal or plastic cover Enclosures with plastic cover do not have UL approval	MHP 16 CS25 MHP 16 CS225 CHP 16 CS CHP 16 CS2	MHP 16 CP25 MHP 16 CP225 CHP 16 CP CHP 16 CP2	M25 M25 × 2 Pg 21 Pg 21 × 2	
	Surface mounting housings, 4 pegs and gasket, with metal or plastic cover, high construction Enclosures with plastic cover do not have UL approval	MAP 16 CS32 MAP 16 CS232 MAP 16 CS40 MAP 16 CS240 CAP 16 CS CAP 16 CS2 CAP 16 CS29 CAP 16 CS229	MAP 16 CP32 MAP 16 CP232 MAP 16 CP40 MAP 16 CP240 CAP 16 CP CAP 16 CP2 CAP 16 CP29 CAP 16 CP229	M32 M32 × 2 M40 M40 × 2 Pg 21 Pg 21 × 2 Pg 29 Pg 29 × 2	

C-TYPE

E

Inserts size 77.27	Poles	Pages	Inserts size 77.27	Poles	Pages	MIXO Modular Inserts	Pages
CNE	16 + ⊕	B.40	CP / CPY	35 A	6 + ⊕	MIXO modules	C.12-93
CCE	16 A	B.46	CSS	16 A	16 + ⊕	CX 04 T (4-slot sized MIXO frames)	C.95
CSH / JSH S	16 A	B.54,60	CT / CTSE*	16 A	16 + ⊕		
CSHT	16 A	B.67	CT / CTS*	10 A	40 + ⊕		
CQE / CQEY	16 A	B.74,84	CMCE / CMSH	16 A	6 + 2 (aux.) + ⊕		
CQEE	16 A	B.78	CX / CXC	80 A/16 A	4/0, 4/2 + ⊕		
CD	10 A	B.90	CX	40 A/10 A	6/12, 6/36, 9/42 and 12/2 + ⊕		
CDD	10 A	B.94					
CDSH	10 A	B.104					

*can be used only in bulkhead mounting housings

Accessories:

CHCP 16
Dust protection cover
Page G.46



C-TYPE series


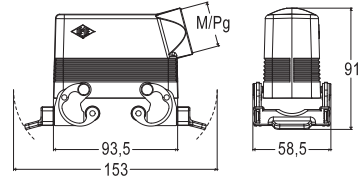

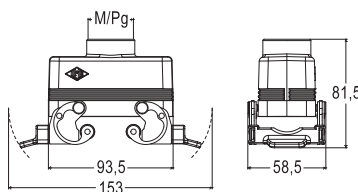

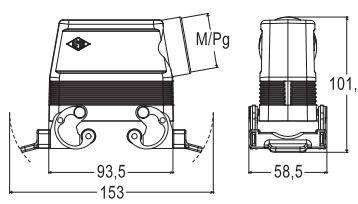

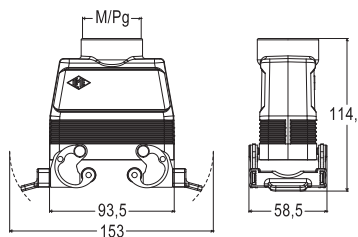
Hoods - 2 levers - without gasket

size **77.27**
Heavy-Duty Applications



EN 60529	IP65 / IP66 / IP69
UL 50 / UL 50E	Type 12 / 4 / 4X
Ambient temperature limits	-40 °C ... +125 °C
Mechanical life (cycles)	≥ 500


 ECBT2.E115072 | ECBT8.E115072

Item	Description	Side entry	Top entry	Entry	Dimension
	Hoods, 2 levers, without gasket, side entry	MHO 16 X25 MHO 16 X32 CHO 16 X		M25 M32 Pg 21	
	Hoods, 2 levers, without gasket, top entry		MHV 16 X25 MHV 16 X32 CHV 16 X	M25 M32 Pg 21	
	Hoods, 2 levers, without gasket, side entry, high construction	MAO 16 X32 MAO 16 X40 CAO 16 X CAO 16 X29		M32 M40 Pg 21 Pg 29	
	Hoods, 2 levers, without gasket, top entry, high construction		MAV 16 X32 MAV 16 X40 CAV 16 X CAV 16 X29	M32 M40 Pg 21 Pg 29	

C-TYPE

E

Inserts size 77.27	Poles	Pages	Inserts size 77.27	Poles	Pages	MIXO Modular Inserts	Pages
CNE 16 A	16 + ⊕	B.40	CP / CPY 35 A	6 + ⊕	B.112-114	MIXO modules	C.12-93
CCE 16 A	16 + ⊕	B.46	CSS 16 A	16 + ⊕	B.120	CX 04 T (4-slot sized MIXO frames)	C.95
CSH / JSH S 16 A	16 + ⊕	B.54-60	CMCE / CMSH 16 A	6 + 2 (aux.) + ⊕	B.143-150		
CSHT 16 A	16 + ⊕	B.67	CX / CXC 80 A/16 A	4/0, 4/2 + ⊕	B.158-160		
CQE / CQEY 16 A	32 + ⊕	B.74-84	CX 40 A/10 A	6/12, 6/36, 9/42 and 12/2 + ⊕	B.163-164, 168-169		
CQEE 16 A	40 + ⊕	B.78					
CD 10 A	40 + ⊕	B.90					
CDD 10 A	72 + ⊕	B.94					
CDSH 10 A	27 + ⊕	B.104					


Accessories:

CHCP 16
Dust protection cover
Page [E.46](#)

C-TYPE series

Covers

size **77.27**




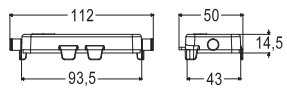



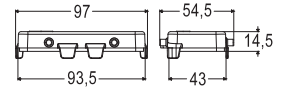


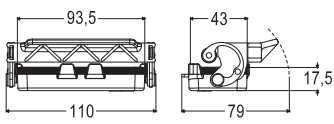

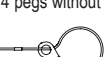
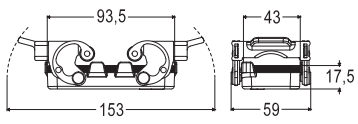


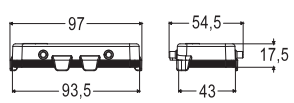
Heavy-Duty Applications 

CE UK CA

CEC DNV SIFITA

EN 60529	IP65 / IP66 / IP69
UL 50 / UL 50E	Type 12 / 4 / 4X
Ambient temperature limits	-40 °C ... +125 °C
Mechanical life (cycles)	≥ 500

CAIUS® ECBT2.E115072 | ECBT8.E115072

Item	Description	With loop	With eyelet	Entry	Dimension
	Covers, 2 pegs, without gasket For enclosures with 1 lever and gasket with loop for hoods  or with eyelet for housings 	CHC 16 SL	CHC 16 L		
	Covers, 4 pegs, without gasket For enclosures with 2 levers and gasket with loop for hoods  or with eyelet for housings 	CHC 16 S	CHC 16		
	Covers, 1 lever and gasket For enclosures with 2 pegs without gasket with loop for hoods 	CHC 16 LG			
	Covers, 2 levers and gasket For enclosures with 4 pegs without gasket with loop for hoods 	CHC 16 G			
	Covers, 4 pegs and gasket For enclosures with 2 levers without gasket with loop for hoods 	CHC 16 C			

C-TYPE

E

C-TYPE series


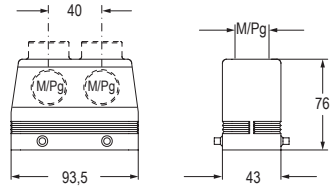

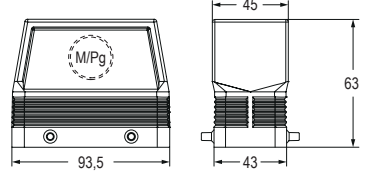

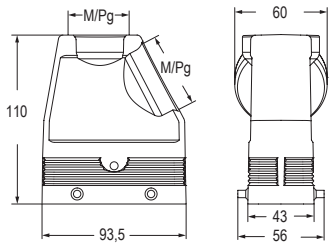
Special enclosures

size **77.27**
Heavy-Duty Applications




EN 60529	IP65 / IP66 / IP69
UL 50 / UL 50E	Type 12 / 4 / 4X
Ambient temperature limits	-40 °C ... +125 °C
Mechanical life (cycles)	≥ 500

 ECBT2.E115072 | ECBT8.E115072

Item	Description	Part No.	Entry	Dimension
	Hoods, 4 pegs, without gasket, 2 top or frontal entries, high construction To be used only with complete cable glands	Frontal entries MFF 16.225 CFF 16.221	Top entries MFV 16.220 MFV 16.225 CFV 16.216 CFV 16.221	M20 × 2 M25 × 2 Pg 16 × 2 Pg 21 × 2 
	Hoods, 4 pegs, without gasket, frontal entry, high construction To be used only with a complete cable gland	Frontal entry MFF 16.25 CFF 16	M25 Pg 21	
	Inclined hoods, 4 pegs, without gasket, side or top entry, high construction To be used only with a complete cable gland	Side entry MIO 16.40 MIO 16.50 CIO 16.36	Top entry MIV 16.40 CIV 16.29	M40 M50 Pg 29 Pg 36 

C-TYPE

E

Inserts size 77.27	Poles	Pages	Inserts size 77.27	Poles	Pages	MIXO Modular Inserts	Pages
CNE	16 A	16 + ⊕ B.40	CP / CPY	35 A	6 + ⊕ B.112,114	MIXO modules	C.12-93
CCE	16 A	16 + ⊕ B.46	CSS	16 A	16 + ⊕ B.120	CX 04 T (4-slot sized MIXO frames)	C.95
CSH / JSH S	16 A	16 + ⊕ B.54,60	CMCE / CMSH	16 A	6 + 2 (aux.) + ⊕ B.145,150		
CSHT	16 A	16 + ⊕ B.67	CX / CXC	80 A/16 A	4/0, 4/2 + ⊕ B.158-160		
CQE / CQEY	16 A	32 + ⊕ B.74,84	CX	40 A/10 A	6/12, 6/36, 9/42 and 12/2 + ⊕ B.163-164, 168-169		
CQEE	16 A	40 + ⊕ B.78					
CD	10 A	40 + ⊕ B.90					
CDD	10 A	72 + ⊕ B.94					
CDSH	10 A	27 + ⊕ B.104					


Accessories:

CHCP 16
 Dust protection cover
 Page G.46

C-TYPE series

Housings and hoods – 1 lever – with gasket

size **104.27**


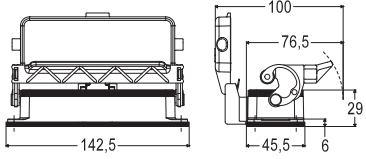

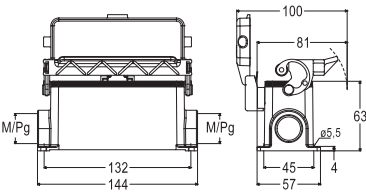

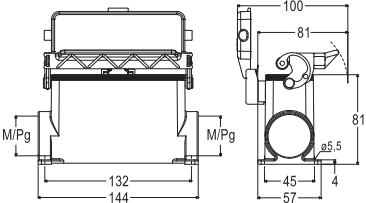

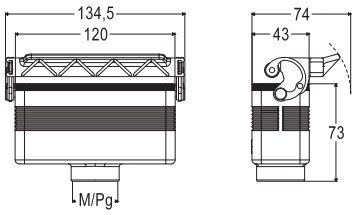

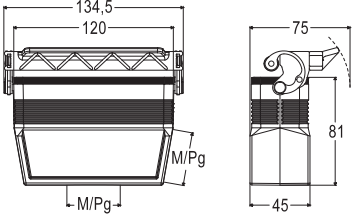
Heavy-Duty Applications 

CE UK CA

CEC DNV VERITAS

EN 60529	IP65 / IP66 / IP69
UL 50 / UL 50E	Type 12 / 4 / 4X
Ambient temperature limits	-40 °C ... +125 °C
Mechanical life (cycles)	≥ 500

CEBUS ECBT2.E115072 | ECBT8.E115072

Item	Description	Part No.	With cover	Entry	Dimension
	Bulkhead mounting housings, 1 lever and gasket, with or without metal cover	CHI 24 L	CHI 24 LS		
	Surface mounting housings, 1 lever and gasket, with or without metal cover	MHP 24 L25 MHP 24 L225 CHP 24 L CHP 24 L2	MHP 24 LS25 MHP 24 LS225 CHP 24 LS CHP 24 LS2	M25 M25 × 2 Pg 21 Pg 21 × 2	
	Surface mounting housings, 1 lever and gasket, with or without metal cover, high construction	MAP 24 L32 MAP 24 L232 MAP 24 L40 MAP 24 L240 CAP 24 L CAP 24 L2 CAP 24 L29 CAP 24 L229	MAP 24 LS32 MAP 24 LS232 MAP 24 LS40 MAP 24 LS240 CAP 24 LS CAP 24 LS2 CAP 24 LS29 CAP 24 LS229	M32 M32 × 2 M40 M40 × 2 Pg 21 Pg 21 × 2 Pg 29 Pg 29 × 2	
	Hoods, 1 lever and gasket, top entry		Top entry MHV 24 LG32 CHV 24 LG	M32 Pg 21	
	Hoods, 1 lever and gasket, side or top entry, high construction To be used only with a complete cable gland	MFO 24 LG40	Side entry Top entry MFV 24 LG25 MFV 24 LG32 CFV 24 LG21 CFV 24 LG29	M25 M32 M40 Pg 21 Pg 29	

Inserts size 104.27	Poles	Pages	Inserts size 104.27	Poles	Pages	MIXO Modular Inserts	Pages
CNE	16 A	24 + ⊕	B.41	CSS	16 A	24 + ⊕	3.124
CCE	16 A	24 + ⊕	B.47	CT / CTSE*	16 A	24 + ⊕	3.129 3.133
CSH / JSH S	16 A	24 + ⊕	B.55 B.71	CT / CTS*	10 A	64 + ⊕	3.139 3.144
CSHT	16 A	24 + ⊕	B.68	CMCE / CMSH	16 A	10 + 2 (aux.) + ⊕	3.146 3.151
CQE / CQEY	16 A	46 + ⊕	B.75 B.83	CX	100 A/16 A	8/0 and 6/6 + ⊕	3.156-157
CQEE	16 A	64 + ⊕	B.79	CX / CXC	80 A/16 A	4/8 + ⊕	3.161-162
CD	10 A	64 + ⊕	B.91	*can be used only in bulkhead mounting housings			
CDD	10 A	108 + ⊕	B.97				
CDSH	10 A	42 + ⊕	B.103				

Accessories:

CHCP 24
Dust protection cover
Page [3.46](#)



C-TYPE

E

C-TYPE series

Hoods - 2 pegs - without gasket

size **104.27**
Heavy-Duty Applications


EN 60529	IP65 / IP66 / IP69
UL 50 / UL 50E	Type 12 / 4 / 4X
Ambient temperature limits	-40 °C ... +125 °C
Mechanical life (cycles)	≥ 500

ECBT2.E115072 | ECBT8.E115072

Item	Description	Side entry	Top entry	Entry	Dimension
	Hoods, 2 pegs, without gasket, side entry	MHO 24 L25 MHO 24 L32 CHO 24 L		M25 M32 Pg 21	
	Hoods, 2 pegs, without gasket, top entry		MHV 24 L25 MHV 24 L32 CHV 24 L	M25 M32 Pg 21	
	Hoods, 2 pegs, without gasket, side or top entry, high construction To be used only with a complete cable gland	MFO 24 L32 MFO 24 L40 CFO 24 L21 CFO 24 L29	MFV 24 L32 MFV 24 L40 CFV 24 L21 CFV 24 L29	M32 M40 Pg 21 Pg 29	
	Hoods, 2 pegs, without gasket, high construction, designed to be drilled		Without entry CAC 24 L		

C-TYPE

E

Inserts size 104.27	Poles	Pages	Inserts size 104.27	Poles	Pages	MIXO Modular Inserts	Pages
CNE	16 A	24 + ⊕ B.41	CSS	16 A	24 + ⊕ B.121	MIXO modules	C.12-93
CCE	16 A	24 + ⊕ B.47	CMCE / CMSH	16 A	10 + 2 (aux.) + ⊕ B.146,151	CX 06 T (6-slot sized MIXO frames)	C.95
CSH / JSH S	16 A	24 + ⊕ B.55,61	CX	100 A/16 A	8/0 and 6/6 + ⊕ B.156-157		
CSHT	16 A	24 + ⊕ B.68	CX / CXC	80 A/16 A	4/8 + ⊕ B.161-162		
CQE / CQEY	16 A	46 + ⊕ B.75,85					
CQEE	16 A	64 + ⊕ B.79					
CD	10 A	64 + ⊕ B.91					
CDD	10 A	108 + ⊕ B.97					
CDSH	10 A	42 + ⊕ B.105					


Accessories:

CHCP 24
Dust protection cover
Page G.46

C-TYPE series

Housings and hoods – 2 levers – with gasket

size **104.27**


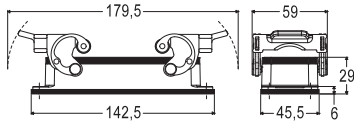

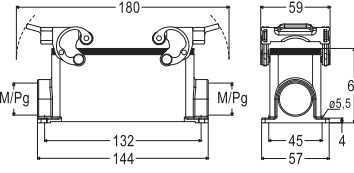

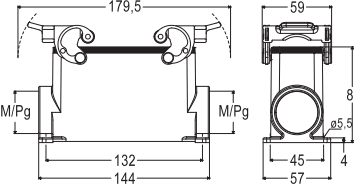

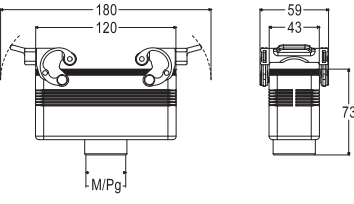

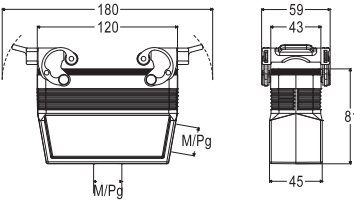
Heavy-Duty Applications 

CE UK CA



EN 60529	IP65 / IP66 / IP69
UL 50 / UL 50E	Type 12 / 4 / 4X
Ambient temperature limits	-40 °C ... +125 °C
Mechanical life (cycles)	≥ 500

CAIUS ECBT2.E115072 | ECBT8.E115072

Item	Description	Part No.	Entry	Dimension
	Bulkhead mounting housings, 2 levers and gasket	CHI 24		
	Surface mounting housings, 2 levers and gasket	MHP 24.25 MHP 24.225 CHP 24 CHP 24.2	M25 M25 × 2 Pg 21 Pg 21 × 2	
	Surface mounting housings, 2 levers and gasket, high construction	MAP 24.25 MAP 24.225 MAP 24.32 MAP 24.232 MAP 24.40 MAP 24.240 CAP 24.21 CAP 24.221 CAP 24.29 CAP 24.229	M25 M25 × 2 M32 M32 × 2 M40 M40 × 2 Pg 21 Pg 21 × 2 Pg 29 Pg 29 × 2	
	Hoods, 2 levers and gasket, top entry		Top entry MHV 24 G32 CHV 24 G	M32 Pg 21 
	Hoods, 2 levers and gasket, side or top entry, high construction To be used only with a complete cable gland	MFO 24 G40	Side entry Top entry MFV 24 G25 MFV 24 G32 MFV 24 G40 CFV 24 G CFV 24 G29	M25 M32 M40 Pg 21 Pg 29 

Inserts size 104.27	Poles	Pages	Inserts size 104.27	Poles	Pages	MIXO Modular Inserts	Pages	
CNE 16 A	24 + ⊕	B.41	CSS 16 A	24 + ⊕	B.121	MIXO modules	C.12-93	
CCE 16 A	24 + ⊕	B.47	CT / CTSE* 16 A	24 + ⊕	B.129 B.133	CX 06 T (6-slot sized MIXO frames)	C.93	
CSH / JSH S 16 A	24 + ⊕	B.55 B.71	CT / CTS* 10 A	64 + ⊕	B.139 B.141			
CSHT 16 A	24 + ⊕	B.68	CMCE / CMSH 16 A	10 + 2 (aux.) + ⊕	B.146 B.151			
CQE / CQEY 16 A	46 + ⊕	B.75 B.83	CX 100 A/16 A	8/0 and 6/6 + ⊕	B.156-157			
CQEE 16 A	64 + ⊕	B.79	CX / CXC 80 A/16 A	4/8 + ⊕	B.161-162			
CD 10 A	64 + ⊕	B.91	*can be used only in bulkhead mounting housings					
CDD 10 A	108 + ⊕	B.97						
CDSH 10 A	42 + ⊕	B.103						

Accessories:

 **CHCP 24**
Dust protection cover
Page [E.46](#)

 **CR LCK**
Locking device
Page [E.43](#)

C-TYPE series

Hoods - 4 pegs - without gasket

size **104.27**
Heavy-Duty Applications
CE UK


EN 60529	IP65 / IP66 / IP69
UL 50 / UL 50E	Type 12 / 4 / 4X
Ambient temperature limits	-40 °C ... +125 °C
Mechanical life (cycles)	≥ 500

CAIUS ECBT2.E115072 | ECBT8.E115072

Item	Description	Side entry	Top entry	Entry	Dimension
	Hoods, 4 pegs, without gasket, side entry	MHO 24.25 MHO 24.32 CHO 24		M25 M32 Pg 21	
	Hoods, 4 pegs, without gasket, top entry		MHV 24.25 MHV 24.32 CHV 24	M25 M32 Pg 21	
	Hoods, 4 pegs, without gasket, side or top entry, high construction To be used only with a complete cable gland	MFO 24.32 MFO 24.40 CFO 24.21 CFO 24.29	MFV 24.32 MFV 24.40 CFV 24.21 CFV 24.29	M32 M40 Pg 21 Pg 29	
	Hoods, 4 pegs, without gasket, high construction, designed to be drilled		Without entry		

C-TYPE

E

Inserts size 104.27	Poles	Pages	Inserts size 104.27	Poles	Pages	MIXO Modular Inserts	Pages		
CNE	16 A	24 + ⊕	B.41	CSS	16 A	24 + ⊕	B.121	MIXO modules	C.12-93
CCE	16 A	24 + ⊕	B.47	CMCE / CMSH	16 A	10 + 2 (aux.) + ⊕	B.146,151	CX 06 T (6-slot sized MIXO frames)	C.95
CSH / JSH S	16 A	24 + ⊕	B.55,61	CX	100 A/16 A	8/0 and 6/6 + ⊕	B.156-157		
CSHT	16 A	24 + ⊕	B.68	CX / CXC	80 A/16 A	4/8 + ⊕	B.161-162		
CQE / CQEY	16 A	46 + ⊕	B.75,85						
CQEE	16 A	64 + ⊕	B.79						
CD	10 A	64 + ⊕	B.91						
CDD	10 A	108 + ⊕	B.97						
CDSH	10 A	42 + ⊕	B.105						

Accessories:

CHCP 24
 Dust protection cover
 Page G.46

C-TYPE series

Housings – 4 pegs – with gasket

size **104.27**


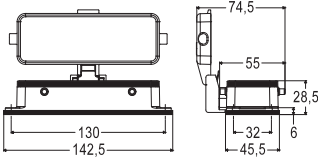

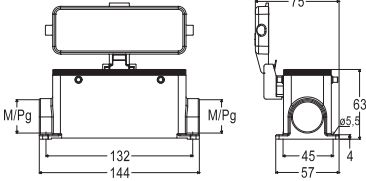

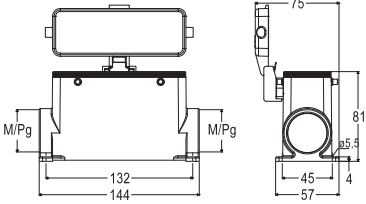
Heavy-Duty Applications 

CE UK CA

CEC DNV SIFITA

EN 60529	IP65 / IP66 / IP69
UL 50 / UL 50E	Type 12 / 4 / 4X
Ambient temperature limits	-40 °C ... +125 °C
Mechanical life (cycles)	≥ 500

CEBUS ECBT2.E115072 | ECBT8.E115072

Item	Description	Metal cover	Plastic cover	Entry	Dimension
	Bulkhead mounting housings, 4 pegs and gasket, with or without metal or plastic cover Enclosures with plastic cover do not have UL approval	CHI 24 CS Without Cover CHI 24 C	CHI 24 CP		
	Surface mounting housings, 4 pegs and gasket, with metal or plastic cover Enclosures with plastic cover do not have UL approval	MHP 24 CS25 MHP 24 CS225 CHP 24 CS CHP 24 CS2	MHP 24 CP25 MHP 24 CP225 CHP 24 CP CHP 24 CP2	M25 M25 × 2 Pg 21 Pg 21 × 2	
	Surface mounting housings, 4 pegs and gasket, with metal or plastic cover, high construction Enclosures with plastic cover do not have UL approval	MAP 24 CS32 MAP 24 CS232 MAP 24 CS40 MAP 24 CS240 CAP 24 CS CAP 24 CS2 CAP 24 CS29 CAP 24 CS229	MAP 24 CP32 MAP 24 CP232 MAP 24 CP40 MAP 24 CP240 CAP 24 CP CAP 24 CP2 CAP 24 CP29 CAP 24 CP229	M32 M32 × 2 M40 M40 × 2 Pg 21 Pg 21 × 2 Pg 29 Pg 29 × 2	

C-TYPE

E

Inserts size 104.27	Poles	Pages	Inserts size 104.27	Poles	Pages	MIXO Modular Inserts	Pages
CNE	16 A	24 + ⊕	B.41	CSS	16 A	24 + ⊕	B.121
CCE	16 A	24 + ⊕	B.47	CT / CTSE*	16 A	24 + ⊕	B.129,133
CSH / JSH S	16 A	24 + ⊕	B.55,61	CT / CTS*	10 A	64 + ⊕	B.139,141
CSHT	16 A	24 + ⊕	B.68	CMCE / CMSH	16 A	10 + 2 (aux.) + ⊕	B.146,151
CQE / CQEY	16 A	46 + ⊕	B.75,85	CX	100 A/16 A	8/0 and 6/6 + ⊕	B.156-157
CQEE	16 A	64 + ⊕	B.79	CX / CXC	80 A/16 A	4/8 + ⊕	B.161-162
CD	10 A	64 + ⊕	B.91	*can be used only in bulkhead mounting housings			
CDD	10 A	108 + ⊕	B.97	*can be used only in bulkhead mounting housings			
CDSH	10 A	42 + ⊕	B.105	*can be used only in bulkhead mounting housings			

Accessories:

 **CHCP 24**
Dust protection cover
Page G.46

C-TYPE series

Hoods - 2 levers - without gasket

size **104.27**
Heavy-Duty Applications

EN 60529	IP65 / IP66 / IP69
UL 50 / UL 50E	Type 12 / 4 / 4X
Ambient temperature limits	-40 °C ... +125 °C
Mechanical life (cycles)	≥ 500

ECBT2.E115072 | ECBT8.E115072

Item	Description	Side entry	Top entry	Entry	Dimension
	Hoods, 2 levers, without gasket, side entry	MHO 24 X25 MHO 24 X32 CHO 24 X		M25 M32 Pg 21	
	Hoods, 2 levers, without gasket, top entry		MHV 24 X25 MHV 24 X32 CHV 24 X	M25 M32 Pg 21	
	Hoods, 2 levers, without gasket, side entry, high construction	MAO 24 X32 MAO 24 X40 CAO 24 X CAO 24 X29		M32 M40 Pg 21 Pg 29	
	Hoods, 2 levers, without gasket, top entry, high construction		MAV 24 X32 MAV 24 X40 CAV 24 X CAV 24 X29	M32 M40 Pg 21 Pg 29	

C-TYPE

E

Inserts size 104.27	Poles	Pages	Inserts size 104.27	Poles	Pages	MIXO Modular Inserts	Pages
CNE	16 A	24 + ⊕	3.41	CSS	16 A	24 + ⊕	3.121
CCE	16 A	24 + ⊕	3.47	CMCE / CMSH	16 A	10 + 2 (aux.) + ⊕	3.148-151
CSH / JSH S	16 A	24 + ⊕	3.53-54	CX	100 A/16 A	8/0 and 6/6 + ⊕	3.156-157
CSHT	16 A	24 + ⊕	3.68	CX / CXC	80 A/16 A	4/8 + ⊕	3.161-162
CQE / CQEY	16 A	46 + ⊕	3.75-83				
CQEE	16 A	64 + ⊕	3.79				
CD	10 A	64 + ⊕	3.91				
CDD	10 A	108 + ⊕	3.97				
CDSH	10 A	42 + ⊕	3.103				


Accessories:

CHCP 24
Dust protection cover
Page [3.46](#)

C-TYPE series

Covers

size **104.27**


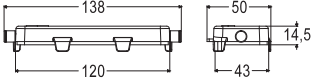

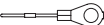

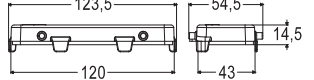



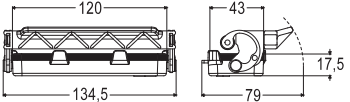


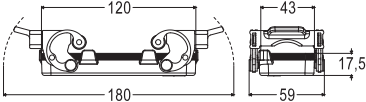


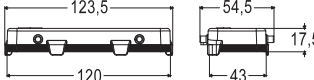
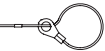
Heavy-Duty Applications 

CE UK CA

CEC DNV SIFITA

EN 60529	IP65 / IP66 / IP69
UL 50 / UL 50E	Type 12 / 4 / 4X
Ambient temperature limits	-40 °C ... +125 °C
Mechanical life (cycles)	≥ 500

CAIUS ECBT2.E115072 | ECBT8.E115072

Item	Description	With loop	With eyelet	Entry	Dimension
	Covers, 2 pegs, without gasket	CHC 24 SL	CHC 24 L		
	For enclosures with 1 lever and gasket with loop for hoods  or with eyelet for housings 				
	Covers, 4 pegs, without gasket	CHC 24 S	CHC 24		
	For enclosures with 2 levers and gasket with loop for hoods  or with eyelet for housings 				
	Covers, 1 lever and gasket	CHC 24 LG			
	For enclosures with 2 pegs without gasket with loop for hoods 				
	Covers, 2 levers and gasket	CHC 24 G			
	For enclosures with 4 pegs without gasket with loop for hoods 				
	Covers, 4 pegs and gasket	CHC 24 C			
	For enclosures with 2 levers without gasket with loop for hoods 				

C-TYPE

E

C-TYPE series

Special enclosures


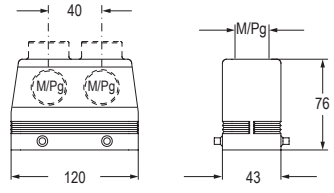

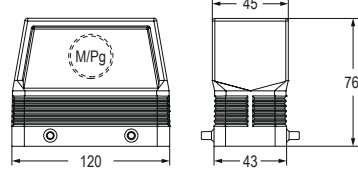

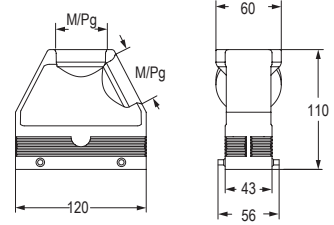

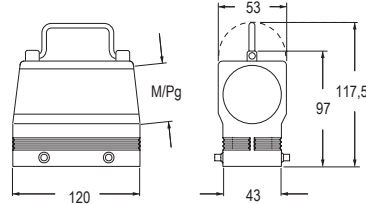

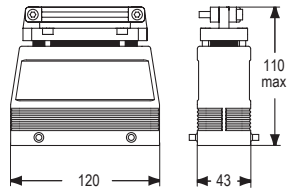
size **104.27**
Heavy-Duty Applications




EN 60529	IP65 / IP66 / IP69
UL 50 / UL 50E	Type 12 / 4 / 4X
Ambient temperature limits	-40 °C ... +125 °C
Mechanical life (cycles)	≥ 500



 ECBT2.E115072 | ECBT8.E115072

Item	Description	Part No.	Entry	Dimension
	Hoods, 4 pegs, without gasket, 2 top or frontal entries, high construction To be used only with complete cable glands	Frontal entries MFF 24.225 CFF 24.221 Top entries MFV 24.232 CFV 24.221	M25 × 2 M32 × 2 Pg21 × 2	
	Hoods, 4 pegs, without gasket, frontal entry, high construction To be used only with a complete cable gland	Frontal entry MFF 24.25 CFF 24	M25 Pg21	
	Inclined hoods, 4 pegs, without gasket, side or top entry, high construction To be used only with a complete cable gland	Side entry MIO 24.40 MIO 24.50 CIO 24.36 Top entry MIV 24.40 MIV 24.50 CIV 24.36	M40 M50 Pg36	
	Enlarged hoods, 4 pegs, without gasket, side or top entry To be used only with a complete cable gland	Side entry MQO 24.40 CQO 24 Top entry MQV 24.40 CQV 24	M40 Pg36	
	Hoods for ribbon cable, 4 pegs, without gasket, top entry and seal gaskets for ribbon cable hoods (supplied separately) These enclosures grant IP44 only	Hood CAN 24 Ribbon seal CRN 1 CRN 2 CRN 3 CRN P	Size (mm) 18,8 × 5,8 63,8 × 5,1 36,0 × 9,0 not pre-drilled	

Inserts size 104.27	Poles	Pages	Inserts size 104.27	Poles	Pages	MIXO Modular Inserts	Pages		
CNE	16 A	24 + ⊕	B.41	CSS	16 A	24 + ⊕	B.121	MIXO modules	C.12-93
CCE	16 A	24 + ⊕	B.47	CMCE / CMSH	16 A	10 + 2 (aux.) + ⊕	B.146,151	CX 06 T (6-slot sized MIXO frames)	C.95
CSH / JSH S	16 A	24 + ⊕	B.55,61	CX	100 A/16 A	8/0 and 6/6 + ⊕	B.156-157		
CSHT	16 A	24 + ⊕	B.68	CX / CXC	80 A/16 A	4/8 + ⊕	B.161-162		
CQE / CQEY	16 A	46 + ⊕	B.75,85						
CQEE	16 A	64 + ⊕	B.79						
CD	10 A	64 + ⊕	B.91						
CDD	10 A	108 + ⊕	B.97						
CDSH	10 A	42 + ⊕	B.105						

Accessories:

CHCP 24
Dust protection cover
Page G.46

C-TYPE series

Housings and hoods – 1 lever – with gasket


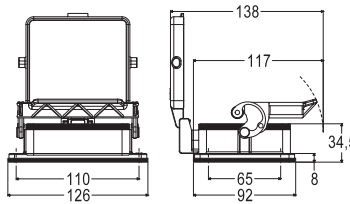

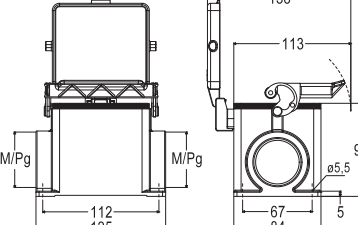

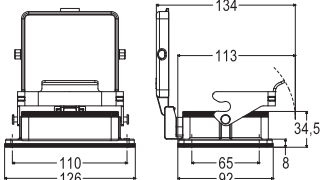

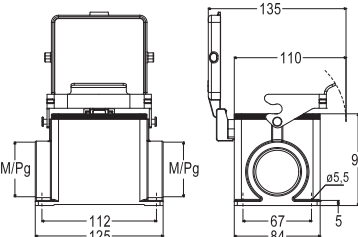

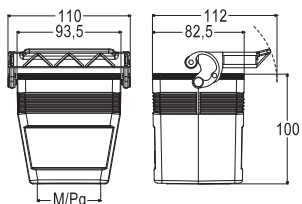
size **77.62**

Heavy-Duty Applications



EN 60529	IP65 / IP66 / IP69
UL 50 / UL 50E	Type 12 / 4 / 4X
Ambient temperature limits	-40 °C ... +125 °C
Mechanical life (cycles)	≥ 500

CEBUS ECBT2.E115072 | ECBT8.E115072

Item	Description	Part No.	With cover	Entry	Dimension
	Bulkhead mounting housings, 1 lever and gasket, with or without metal cover	CHI 32 L	CHI 32 LS		
	Surface mounting housings, 1 lever and gasket, with or without metal cover	MHP 32 L40 MHP 32 L240 MHP 32 L50 MHP 32 L250 CHP 32 L29 CHP 32 L229 CHP 32 L CHP 32 L2 CHP 32 L42 CHP 32 L242	MHP 32 LS40 MHP 32 LS240 MHP 32 LS50 MHP 32 LS250 CHP 32 LS29 CHP 32 LS229 CHP 32 LS CHP 32 LS2 CHP 32 LS42 CHP 32 LS242	M40 M40 × 2 M50 M50 × 2 Pg 29 Pg 29 × 2 Pg 36 Pg 36 × 2 Pg 42 Pg 42 × 2	
	Bulkhead mounting housings, 1 stainless steel rigid lever and gasket, with or without metal or plastic cover	Metal cover CHIX 32 LS Without cover CHIX 32 L	CHIX 32 LP		
	Surface mounting housings, 1 stainless steel rigid lever and gasket, with or without metal or plastic cover	Metal cover MHPX 32 LS40 CHPX 32 LS29 CHPX 32 LS Without cover MHPX 32 L40 CHPX 32 L29 CHPX 32 L	MHPX 32 LP40 MHPX 32 LP50 CHPX 32 LP29 CHPX 32 LP	M40 M50 Pg 29 Pg 36 M40 Pg 29 Pg 36	
	Hoods, 1 lever and gasket, top entry		Top entry MFV 32 LG40 CFV 32 LG	M42 Pg 36	

C-TYPE

E

Inserts size (77.27) × 2	Poles	Pages	Inserts size (77.27) × 2	Poles	Pages
CNE 16 A	32 + ⊕	3.42	CSS 16 A	32 + ⊕	3.122
CCE 16 A	32 + ⊕	3.48	CTSE* 16 A	32 + ⊕	3.134
CSH / JSH S 16 A	32 + ⊕	3.58, 32	CMCE / CMSH 16 A	12 + 4 (aux.) + ⊕	3.147, 152
CQE / CQEY 16 A	64 + ⊕	3.76, 36	*can be used only in bulkhead mounting housings		
CD 10 A	80 + ⊕	3.92	MIXO Modular Inserts		
CDD 10 A	144 + ⊕	3.98	MIXO modules		C.12-93
CDSH 10 A	54 + ⊕	3.106	CX 04 T (4-slot sized MIXO frames) × 2		C.95
CP / CPY 35 A	12 + ⊕	3.113, 115			

C-TYPE series

Hoods – 2 pegs – without gasket

size 77.62


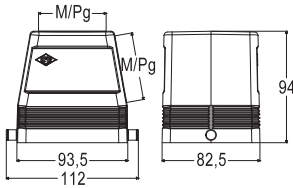
Heavy-Duty Applications

CE UK CA



EN 60529	IP65 / IP66 / IP69
UL 50 / UL 50E	Type 12 / 4 / 4X
Ambient temperature limits	-40 °C ... +125 °C
Mechanical life (cycles)	≥ 500

ALUS ECBT2.E115072 | ECBT8.E115072


Item	Description	Side entry	Top entry	Entry	Dimension
	<p>Hoods, 2 pegs, without gasket, side or top entry</p> <p>To be used only with a complete cable gland</p>	MFO 32 L40 CFO 32 L	MFV 32 L40 CFO 32 L	M40 Pg 36	

Inserts size (77.27) × 2	Poles	Pages	Inserts size (77.27) × 2	Poles	Pages
CNE	16 A	32 + ⊕ B.42	CSS	16 A	32 + ⊕ B.122
CCE	16 A	32 + ⊕ B.48	CMCE / CMSH	16 A	12 + 4 (aux.) + ⊕ B.147,152
CSH / JSH S	16 A	32 + ⊕ B.56,62			
CQE / CQEY	16 A	64 + ⊕ B.76,86			
CD	10 A	80 + ⊕ B.92			
CDD	10 A	144 + ⊕ B.98			
CDSH	10 A	54 + ⊕ B.106			
CP / CPY	35 A	12 + ⊕ B.113,115			
			MIXO Modular Inserts		Pages
			MIXO modules		C.12-93
			CX 04 T (4-slot sized MIXO frames) × 2		C.95

C-TYPE series

Housings and hoods – 2 levers – with gasket

size **77.62**


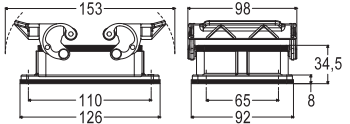

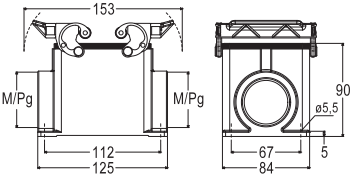

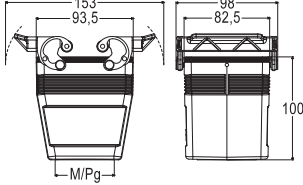
Heavy-Duty Applications 

CE UK CA

EN 60529	IP65 / IP66 / IP69
UL 50 / UL 50E	Type 12 / 4 / 4X
Ambient temperature limits	-40 °C ... +125 °C
Mechanical life (cycles)	≥ 500



CAIUS ECBT2.E115072 | ECBT8.E115072

Item	Description	Part No.	With cover	Entry	Dimension
	Bulkhead mounting housings, 2 levers and gasket	CHI 32			
	Surface mounting housings, 2 levers and gasket	MHP 32.40 MHP 32.240 MHP 32.50 MHP 32.250 CHP 32.29 CHP 32.229 CHP 32 CHP 32.2 CHP 32.42 CHP 32.242		M40 M40 × 2 M50 M50 × 2 Pg 29 Pg 29 × 2 Pg 36 Pg 36 × 2 Pg 42 Pg 42 × 2	
	Hoods, 2 levers and gasket, top entry To be used only with a complete cable gland		Top entry	MFV 32 G32 MFV 32 G40 MFV 32 G50 CFV 32 G29 CFV 32 G CFV 32 G42	M32 M40 M50 Pg 29 Pg 36 Pg 42 

C-TYPE


E

Inserts size (77.27) × 2	Poles	Pages	Inserts size (77.27) × 2	Poles	Pages
CNE 16 A	32 + ⊕	B.42	CSS 16 A	32 + ⊕	B.122
CCE 16 A	32 + ⊕	B.48	CTSE* 16 A	32 + ⊕	B.134
CSH / JSH S 16 A	32 + ⊕	B.56,62	CMCE / CMSH 16 A	12 + 4 (aux.) + ⊕	B.147,152
CQE / CQEY 16 A	64 + ⊕	B.76,86	*can be used only in bulkhead mounting housings		
CD 10 A	80 + ⊕	B.92	MIXO Modular Inserts		
CDD 10 A	144 + ⊕	B.98	Pages		
CDSH 10 A	54 + ⊕	B.106	MIXO modules C.12-93		
CP / CPY 35 A	12 + ⊕	B.113,115	CX 04 T (4-slot sized MIXO frames) × 2 C.95		

C-TYPE series

Hoods – 4 pegs – without gasket

size 77.62


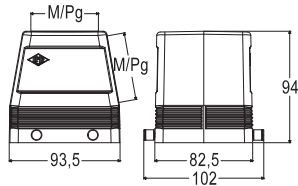
Heavy-Duty
Applications 

CE UK
CA



CAUS ECBT2.E115072 | ECBT8.E115072

EN 60529	IP65 / IP66 / IP69
UL 50 / UL 50E	Type 12 / 4 / 4X
Ambient temperature limits	-40 °C ... +125 °C
Mechanical life (cycles)	≥ 500

Item	Description	Side entry	Top entry	Entry	Dimension
	Hoods, 2 pegs, without gasket, side or top entry To be used only with a complete cable gland	MFO 32.32 MFO 32.40 MFO 32.50 CFO 32.29 CFO 32 CFO 32.42	MFV 32.32 MFV 32.40 MFV 32.50 CFV 32.29 CFV 32 CFV 32.42	M32 M40 M50 Pg 29 Pg 36 Pg 42	


Inserts size (77.27) × 2	Poles	Pages	Inserts size (77.27) × 2	Poles	Pages
CNE 16 A	32 + ⊕	B.42	CSS 16 A	32 + ⊕	B.122
CCE 16 A	32 + ⊕	B.48	CMCE / CMSH 16 A	12 + 4 (aux.) + ⊕	B.147,152
CSH / JSH S 16 A	32 + ⊕	B.56,62			
CQE / CQEY 16 A	64 + ⊕	B.76,86			
CD 10 A	80 + ⊕	B.92			
CDD 10 A	144 + ⊕	B.98	MIXO Modular Inserts		Pages
CDSH 10 A	54 + ⊕	B.106	MIXO modules		C.12-93
CP / CPY 35 A	12 + ⊕	B.113,115	CX 04 T (4-slot sized MIXO frames) × 2		C.95

C-TYPE series

size **77.62**

Housings – 4 pegs – with gasket


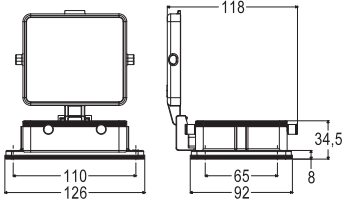

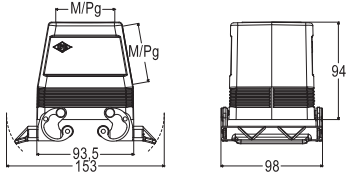
Hoods – 2 levers – without gasket

Heavy-Duty Applications 

EN 60529	IP65 / IP66 / IP69
UL 50 / UL 50E	Type 12 / 4 / 4X
Ambient temperature limits	-40 °C ... +125 °C
Mechanical life (cycles)	≥ 500



CAIUS ECBT2.E115072 | ECBT8.E115072

Item	Description	Part No.	With cover	Entry	Dimension
	Bulkhead mounting housings, 4 pegs and gasket, with metal cover		CHI 32 CS		
	Hoods, 2 levers, without gasket, side or top entry To be used only with a complete cable gland	Side entry MFO 32 X40 CFO 32 X	Top entry MFV 32 X40 CFV 32 X	M40 Pg 36	

C-TYPE

E

Inserts size (77.27) × 2	Poles	Pages	Inserts size (77.27) × 2	Poles	Pages
CNE	16 A	32 + ⊕ B.42	CSS	16 A	32 + ⊕ B.122
CCE	16 A	32 + ⊕ B.48	CTSE*	16 A	32 + ⊕ B.134
CSH / JSH S	16 A	32 + ⊕ B.56,62	CMCE / CMSH	16 A	12 + 4 (aux.) + ⊕ B.147,152
CQE / CQEY	16 A	64 + ⊕ B.76,86	*can be used only in bulkhead mounting housings		
CD	10 A	80 + ⊕ B.92			
CDD	10 A	144 + ⊕ B.98			
CDSH	10 A	54 + ⊕ B.106			
CP / CPY	35 A	12 + ⊕ B.113,115			
			MIXO Modular Inserts		
			MIXO modules		C.12-93
			CX 04 T (4-slot sized MIXO frames) × 2		C.95

C-TYPE series

Covers

size **77.62**
Heavy-Duty Applications

EN 60529	IP65 / IP66 / IP69
UL 50 / UL 50E	Type 12 / 4 / 4X
Ambient temperature limits	-40 °C ... +125 °C
Mechanical life (cycles)	≥ 500

ECBT2.E115072 | ECBT8.E115072

Item	Description	With loop	With eyelet	Entry	Dimension
	Covers, 2 pegs, without gasket For enclosures with 1 lever and gasket with loop for hoods or with eyelet for housings	CHC 32 SL	CHC 32 L		
	Covers, 4 pegs, without gasket For enclosures with 2 levers and gasket with loop for hoods or with eyelet for housings	CHC 32 S	CHC 32		
	Covers, 1 lever and gasket For enclosures with 2 pegs without gasket with loop for hoods	CHC 32 LG			
	Covers, 2 levers and gasket For enclosures with 4 pegs without gasket with loop for hoods	CHC 32 G			
	Covers, 4 pegs and gasket For enclosures with 2 levers without gasket with loop for hoods	CHC 32 C			

C-TYPE series

Housings – 1 lever – with gasket

size **104.62**


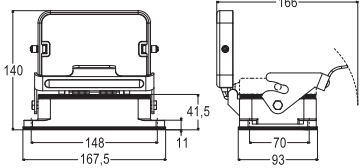

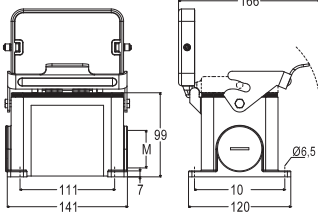
Heavy-Duty Applications 

CE UK CA

CEC DNV SIFITA

EN 60529	IP65 / IP66 / IP69
UL 50 / UL 50E	Type 12 / 4 / 4X
Ambient temperature limits	-40 °C ... +125 °C
Mechanical life (cycles)	≥ 500

ALUS® ECBT2.E115072 | ECBT8.E115072

Item	Description	Part No.	With cover	Entry	Dimension
	Bulkhead mounting housings, 1 stainless steel rigid lever and gasket, with or without metal cover	CHI 48 L	CHI 48 LS		
	Surface mounting housings, 1 stainless steel rigid lever and gasket, with metal cover		MHP 48 LS40 MHP 48 LS50 CHP 48 LS29 CHP 48 LS	M40 × 2 M50 × 2 Pg 29 × 2 Pg 36 × 2	

Inserts size (104.27) × 2	Poles	Pages	Inserts size (104.27) × 2	Poles	Pages
CNE 16 A	48 + ⊕	B.43	CTSE* 16 A	48 + ⊕	B.135
CCE 16 A	48 + ⊕	B.49	CMCE / CMSH 16 A	10 + 2 (aux.) + ⊕	B.148,153
CSH / JSH S 16 A	48 + ⊕	B.57,63	*can be used only in bulkhead mounting housings		
CQE / CQEY 16 A	92 + ⊕	B.77,87			
CD 10 A	128 + ⊕	B.93			
CDD 10 A	216 + ⊕	B.99			
CDSH 10 A	84 + ⊕	B.107			
CSS 16 A	48 + ⊕	B.123			
			MIXO Modular Inserts		Pages
			MIXO modules		C.12-93
			CX 06 T (6-slot sized MIXO frames) × 2		C.95



C-TYPE series

Hoods - 2 pegs - without gasket

size **104.62**
Heavy-Duty Applications


EN 60529	IP65 / IP66 / IP69
UL 50 / UL 50E	Type 12 / 4 / 4X
Ambient temperature limits	-40 °C ... +125 °C
Mechanical life	≥ 500 cycles

ECBT2.E115072 | ECBT8.E115072

Item	Description	Side entry	Top entry	Entry	Dimension
	Hoods, 2 pegs, without gasket, side entry To be used only with a complete cable gland	MFO 48 L32 MFO 48 L40 MFO 48 L50 CFO 48 L29 CFO 48 L CFO 48 L42		M32 M40 M50 Pg29 Pg36 Pg42	
	Hoods, 2 pegs, without gasket, top entry To be used only with a complete cable gland		MFV 48 L32 MFV 48 L40 MFV 48 L50 MFV 48 L63 CFV 48 L29 CFV 48 L CFV 48 L42	M32 M40 M50 M63 Pg 29 Pg 36 Pg 42	

Inserts size (104.27) × 2	Poles	Pages	Inserts size (104.27) × 2	Poles	Pages
CNE	16 A	48 + ⊕ B.43	CMCE / CMSH	16 A	10 + 2 (aux.) + ⊕ B.148,153
CCE	16 A	48 + ⊕ B.49			
CSH / JSH S	16 A	48 + ⊕ B.57,63			
CQE / CQEY	16 A	92 + ⊕ B.77,87			
CD	10 A	128 + ⊕ B.93			
CDD	10 A	216 + ⊕ B.99			
CDSH	10 A	84 + ⊕ B.107			
CSS	16 A	48 + ⊕ B.123			
			MIXO Modular Inserts		Pages
			MIXO modules		C.12-93
			CX 06 T (6-slot sized MIXO frames) × 2		C.95

Panel cut-out drawings

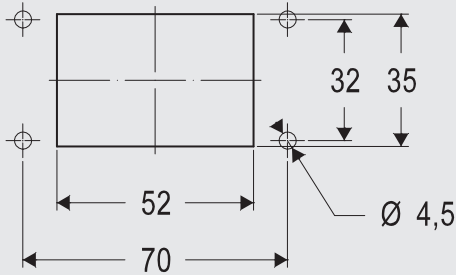
For C-TYPE series bulkhead mounting housings

To guarantee the declared IP degree of protection of the housings reported in this catalogue, according to EN IEC 60529 or to the relevant Type rating per ANSI/UL 50 and 50E (for those products bearing approval to those ratings), the surface of the mounting panel must meet the following requirements (definitions are provided in ISO 4287 standard):

Waviness $W_t \leq 0,2$ mm over a distance of 200 mm
(measured on the panel without load)
Roughness $R_a \leq 16$ μ m

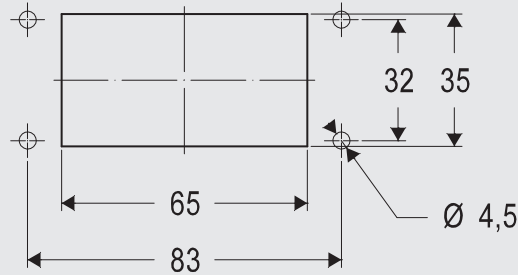
Scale 1:2

Size 44.27



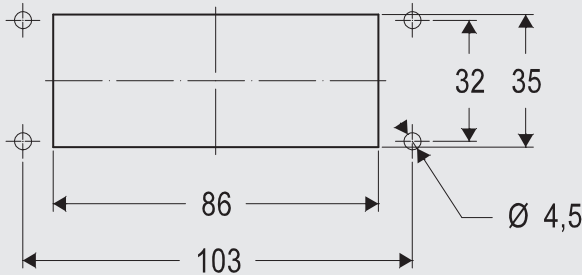
Required screws: 4
Screws size: M4
Recommended torque:
0,8 – 1,2 Nm / 7.1 – 10.6 lb.in

Size 57.27



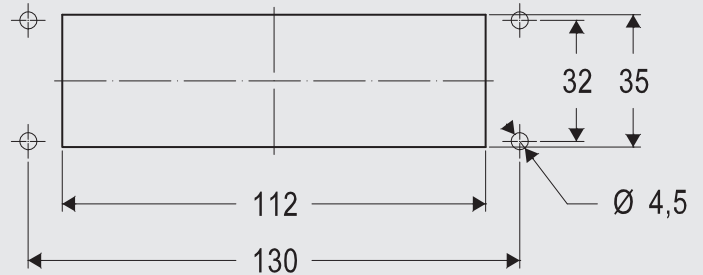
Required screws: 4
Screws size: M4
Recommended torque:
0,8 – 1,2 Nm / 7.1 – 10.6 lb.in

Size 77.27



Required screws: 4
Screws size: M4
Recommended torque:
0,8 – 1,2 Nm / 7.1 – 10.6 lb.in

Size 104.27



Required screws: 4
Screws size: M4
Recommended torque:
0,8 – 1,2 Nm / 7.1 – 10.6 lb.in

Notes: The values of tightening torque indicated above are just recommended values, that must be related – by the designer of the final application – to the resistance class of the screws (not included), with the assumption that the mounting panel is sufficiently rigid (stiff). If the deflection of the panel, under the effect of tightening the screws, is greater than 0,7 mm over a distance of 100 mm, it is

necessary to use the counter-flanges mentioned in our catalogue or the special flange gaskets available upon request (please contact our Sales Department).

Panel cut-out drawings

For C-TYPE series bulkhead mounting housings

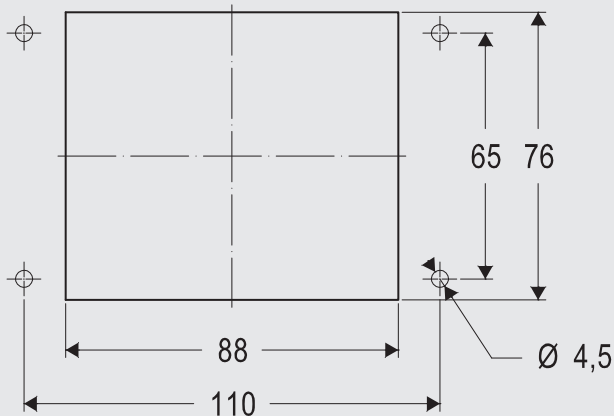
To guarantee the declared IP degree of protection of the housings reported in this catalogue, according to EN IEC 60529 or to the relevant Type rating per ANSI/UL 50 and 50E (for those products bearing approval to those ratings), the surface of the mounting panel must meet the following requirements (definitions are provided in ISO 4287 standard):

Waviness $W_t \leq 0,2$ mm over a distance of 200 mm
(measured on the panel without load)

Roughness $R_a \leq 16$ μm

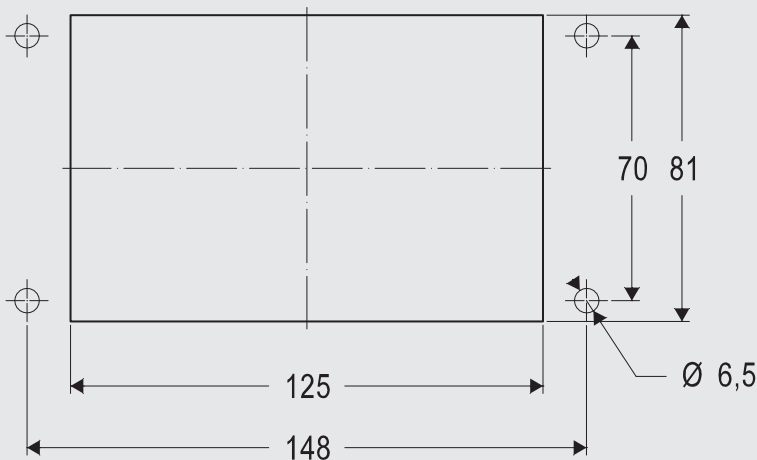
Scale 1:2

Size 77.62



Required screws: 4
Screws size: M4
Recommended torque:
1,2 – 1,8 Nm / 10.6 – 15.9 lb.in

Size 104.62



Required screws: 4
Screws size: M6
Recommended torque:
3,0 – 3,6 Nm / 26.6 – 31.9 lb.in

Notes: The values of tightening torque indicated above are just recommended values, that must be related – by the designer of the final application – to the resistance class of the screws (not included), with the assumption that the mounting panel is sufficiently rigid (stiff). If the deflection of the panel, under the effect of tightening the screws, is greater than 0,7 mm over a distance of 100 mm, it is

necessary to use the counter-flanges mentioned in our catalogue or the special flange gaskets available upon request (please contact our Sales Department).

IL-BRID

Soft closing, strong hold



Standard enclosures with IL-BRID levers

Specific industrial applications demand the design of equally customized connection solutions capable of covering each distinct installation requirement.

Among the enclosures' locking systems introduced by ILME in its product offer, the IL-BRID mechanism, a lever in thermoplastic material with a stainless-steel core, combines the technical characteristics of both these materials for durable but significantly low-wear design.



Watch our clip

SUM-UP

CL – ML series

- > Made of die cast aluminium alloy
- > Gaskets in anti-aging, oil-resistant, grease-resistant and fuel resistant vinyl nitrile elastomer
- > IL-BRID locking device in self-extinguishing thermoplastic material and stainless steel core
- > Ambient temperature range: -40 °C / +125 °C

≡ Markings and Approvals

- CE and UK markings, EAC not applicable
- UL certified for USA and Canada for Type 12, 4 and 4X degrees of protection (enclosure type ratings, equivalent to NEMA rating)
- IP65 / IP66 / IP69 degree of protection
- RoHS: compliant

FOCUS

Levers and technology

The IL-BRID mechanism, a lever made of thermoplastic with a stainless-steel core, combines the technical characteristics of both materials for a durable but significantly low-wear design.

The IL-BRID locking lever is compatible with the entire range of ILME enclosures with pegs (in single or double-lever configuration) and offers an IP65 or IP66 / IP69 degree of protection, depending on the model.



▶ Thermoplastic handle

▶ Stainless-steel core

▶ V-shaped ribs to improve stiffness of handles



▶ Soft closing 1st touch




▶ Strong hold 2nd touch



IL-BRID series

Housings and covers – 1 lever – with gasket

size **44.27**


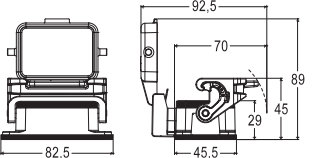

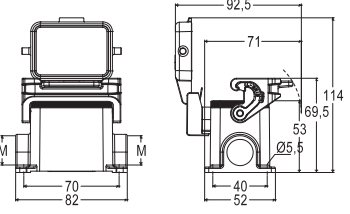

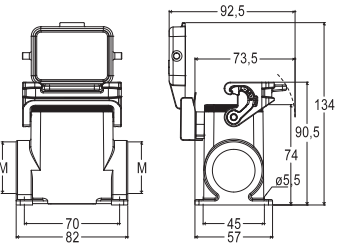

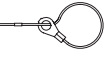
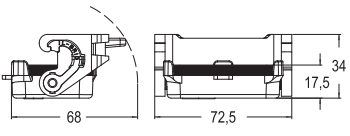
Heavy-Duty Applications 

CE UK

EN 60529	IP65 / IP66 / IP69
UL 50 / UL 50E	Type 12 / 4 / 4X
Ambient temperature limits	-40 °C ... +125 °C
Mechanical life (cycles)	≥ 500

 (pending CQC)

 ECBT2.E115072 | ECBT8.E115072

Item	Description	Part No.	With cover	Entry	Dimension
	Bulkhead mounting housings, 1 lever and gasket, with or without metal cover	CLI 06 L	CLI 06 LS		
	Surface mounting housings, 1 lever and gasket, with or without metal cover	MLP 06 L20 MLP 06 L220	MLP 06 LS20 MLP 06 LS220	M20 M20 × 2	
	Surface mounting housings, 1 lever and gasket, with or without metal cover high construction To be used only with a complete cable gland	MLAP 06 L25 MLAP 06 L225 MLAP 06 L32 MLAP 06 L232 MLAP 06 L40 MLAP 06 L240	MLAP 06 LS32 MLAP 06 LS232 MLAP 06 LS40 MLAP 06 LS240	M25 M25 × 2 M32 M32 × 2 M40 M40 × 2	
	Covers, 1 lever and gasket For enclosures with 2 pegs without gasket with loop for hoods 	CLC 06 LG			

IL-BRID
E

Inserts size 44.27	Poles	Pages	MIXO Modular Inserts	Pages
CNE	16 A	6 + ⊕	MIXO modules	C.12-93
CCE	16 A	6 + ⊕	CX 02 T (2-slot sized MIXO frames)	C.95
CSH / JSH S	16 A	6 + ⊕		
CQE / CQEY	16 A	10 + ⊕		
CDD	10 A	24 + ⊕		
CDSH / CDSH NC	10 A	9 and 6 + ⊕		
CSS	16 A	6 + ⊕		
CT / CTSE*	16 A	6 + ⊕		

Complete with:



Hoods
Page [E.49](#)



Covers
Page [E.52](#)

*can be used only in bulkhead mounting housings

IL-BRID series

Hoods – 1 lever – with gasket

size 44.27

Heavy-Duty Applications

CE UK

EN 60529	IP65 / IP66 / IP69
UL 50 / UL 50E	Type 12 / 4 / 4X
Ambient temperature limits	-40 °C ... +125 °C
Mechanical life (cycles)	≥ 500

(pending CQC)

ECBT2.E115072 | ECBT8.E115072

Item	Description	Side entry	Top entry	Entry	Dimension
	Hoods, 1 lever and gasket, top entry		MLV 06 LG25	M25	
	Hoods, 1 lever and gasket, top entry, high construction, with metal adapter		MLAV 06 LG25 MLAV 06 LG32	M25 M32	
	Hoods, 1 lever and gasket, side or top entry, high construction To be used only with a complete cable gland	MLFO 06 LG40	MLFV 06 LG25 MLFV 06 LG32 MLFV 06 LG40	M25 M32 M40	

Inserts size 44.27	Poles	Pages	MIXO Modular Inserts	Pages	
CNE	16 A	6 + ⊕	B.38	MIXO modules	C.12-93
CCE	16 A	6 + ⊕	B.44	CX 02 T (2-slot sized MIXO frames)	C.95
CSH / JSH S	16 A	6 + ⊕	B.52,58		
CQE / CQEY	16 A	10 + ⊕	B.72,82		
CDD	10 A	24 + ⊕	B.94		
CDSH / CDSH NC	10 A	9 and 6 + ⊕	B.102,108		
CSS	16 A	6 + ⊕	B.118		

Complete with:



Hoods
Page E.49




Covers
Page E.52

IL-BRID series

Housings and covers – 1 lever – with gasket


size **57.27**


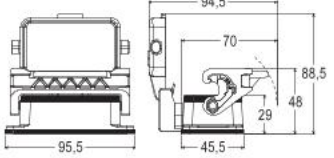

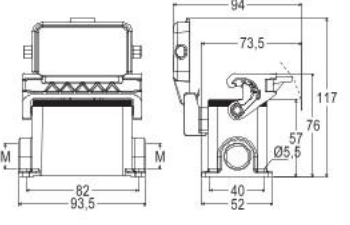

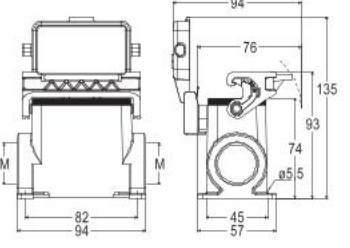


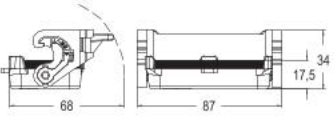
Heavy-Duty Applications 

CE UK CA

EN 60529	IP65 / IP66 / IP69
UL 50 / UL 50E	Type 12 / 4 / 4X
Ambient temperature limits	-40 °C ... +125 °C
Mechanical life (cycles)	≥ 500

 (pending CQC)

 ECBT2.E115072 | ECBT8.E115072

Item	Description	Part No.	With cover	Entry	Dimension
	Bulkhead mounting housings, 1 lever and gasket, with or without metal cover	CLI 10 L	CLI 10 LS		
	Surface mounting housings, 1 lever and gasket, with or without metal cover	MLP 10 L20 MLP 10 L220	MLP 10 LS20 MLP 10 LS220	M20 M20 × 2	
	Surface mounting housings, 1 lever and gasket, with or without metal cover high construction	MLAP 10 L32 MLAP 10 L232 MLAP 10 L40 MLAP 10 L240	MLAP 10 LS32 MLAP 10 LS232 MLAP 10 LS40 MLAP 10 LS240	M32 M32 × 2 M40 M40 × 2	
	Covers, 1 lever and gasket For enclosures with 2 pegs without gasket with loop for hoods 	CLC 10 LG			

IL-BRID
E

Inserts size 57.27	Poles	Pages	Inserts size 57.27	Poles	Pages
CNE	16 A	10 + ⊕	CT / CTSE*	16 A	10 + ⊕
CCE	16 A	10 + ⊕	CMCE / CMSH	16 A	3 + 2 (aux.) + ⊕
CSH / JSH S	16 A	10 + ⊕	CX	40 A/10 A	8/24 + ⊕
CSHT	16 A	10 + ⊕			
CQE / CQEY	16 A	18 + ⊕			
CDD	10 A	42 + ⊕			
CDSH	10 A	18 + ⊕			
CSS	16 A	10 + ⊕			
			MIXO Modular Inserts		Pages
			MIXO modules		C.12-93
			CX 03 T (3-slot sized MIXO frames)		C.93

Complete with:



Hoods
Page [E.53](#)



Covers
Page [E.60](#)

IL-BRID series

Hoods – 1 lever – with gasket

size 57.27


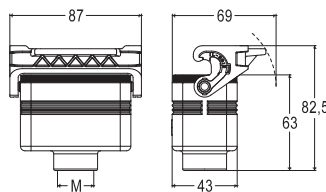

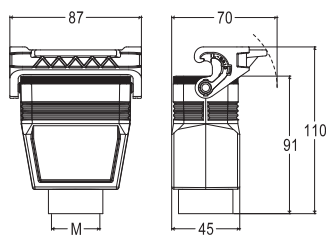

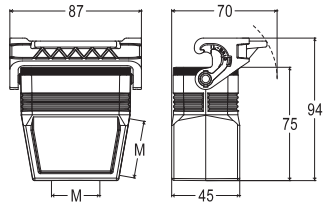
Heavy-Duty Applications

CE UK

EN 60529	IP65 / IP66 / IP69
UL 50 / UL 50E	Type 12 / 4 / 4X
Ambient temperature limits	-40 °C ... +125 °C
Mechanical life (cycles)	≥ 500

 (pending CQC)

 ECBT2.E115072 | ECBT8.E115072

Item	Description	Side entry	Top entry	Entry	Dimension
	Hoods, 1 lever and gasket, top entry		MLV 10 LG25	M25	
	Hoods, 1 lever and gasket, top entry, high construction, with metal adapter		MLAV 10 LG25 MLAV 10 LG32	M25 M32	
	Hoods, 1 lever and gasket, side or top entry, high construction To be used only with a complete cable gland	MLFO 06 LG40	MLFV 10 LG25 MLFV 10 LG32 MLFV 10 LG40	M25 M32 M40	

IL-BRID

E

Inserts size 57.27	Poles	Pages	Inserts size 57.27	Poles	Pages		
CNE	16 A	10 + ⊕	B.39	CMCE / CMSH	16 A	3 + 2 (aux.) + ⊕	B.144,149
CCE	16 A	10 + ⊕	B.45	CX	40 A/10 A	8/24 + ⊕	B.170-171
CSH / JSH S	16 A	10 + ⊕	B.53,59				
CSHT	16 A	10 + ⊕	B.66				
CQE / CQEY	16 A	18 + ⊕	B.73,83				
CDD	10 A	42 + ⊕	B.95	MIXO Modular Inserts		Pages	
CDSH	10 A	18 + ⊕	B.103	MIXO modules		C.12-93	
CSS	16 A	10 + ⊕	B.119	CX 03 T (3-slot sized MIXO frames)		C.95	

Complete with:


Hoods
Page E.55

Covers
Page E.60

IL-BRID series

Housings and covers – 2 levers – with gasket


size **57.27**


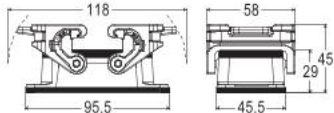

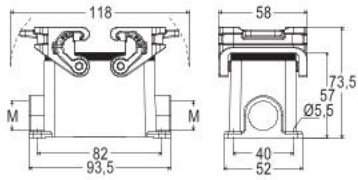

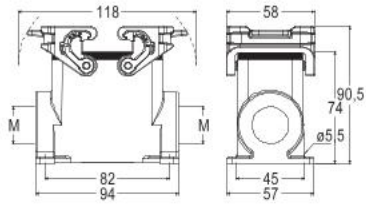


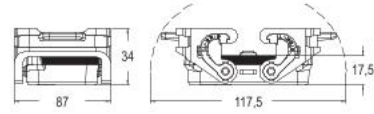
Heavy-Duty Applications 

CE UK

EN 60529	IP65 / IP66 / IP69
UL 50 / UL 50E	Type 12 / 4 / 4X
Ambient temperature limits	-40 °C ... +125 °C
Mechanical life (cycles)	≥ 500

 (pending CQC)

 ECBT2.E115072 | ECBT8.E115072

Item	Description	Part No.	Entry	Dimension
	Bulkhead mounting housings, 2 levers and gasket	CLI 10		
	Surface mounting housings, 2 levers and gasket	MLP 10.20 MLP 10.220	M20 M20 × 2	
	Surface mounting housings, 2 levers and gasket, high construction	MLAP 10.25 MLAP 10.225 MLAP 10.32 MLAP 10.232 MLAP 10.40 MLAP 10.240	M25 M25 × 2 M32 M32 × 2 M40 M40 × 2	
	Covers, 2 levers and gasket For enclosures with 4 pegs without gasket with loop for hoods 	CLC 10 G		

Inserts size 57.27	Poles	Pages	Inserts size 57.27	Poles	Pages
CNE	16 A	10 + ⊕	CT / CTSE*	16 A	10 + ⊕
CCE	16 A	10 + ⊕	CMCE / CMSH	16 A	3 + 2 (aux.) + ⊕
CSH / JSH S	16 A	10 + ⊕	CX	40 A/10 A	8/24 + ⊕
CSHT	16 A	10 + ⊕			
CQE / CQEY	16 A	18 + ⊕			
CDD	10 A	42 + ⊕			
CDSH	10 A	18 + ⊕			
CSS	16 A	10 + ⊕			

*can be used only in bulkhead mounting housings

MIXO Modular Inserts	Pages
MIXO modules	C.12-93
CX 03 T (3-slot sized MIXO frames)	C.93

Complete with:



Hoods
Page [E.57](#) [E.61](#)




Covers
Page [E.60](#)

IL-BRID series

Hoods - 2 levers - with gasket

size 57.27


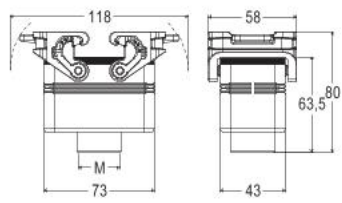

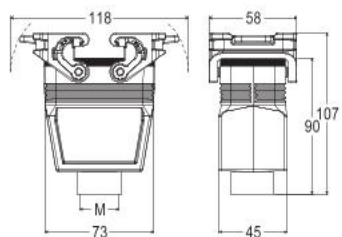

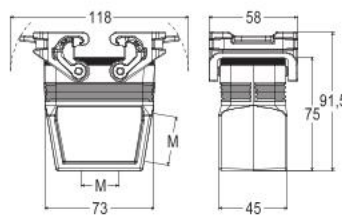
Heavy-Duty Applications 

CE UK

 (pending CQC)

 ECBT2.E115072 | ECBT8.E115072

EN 60529	IP65 / IP66 / IP69
UL 50 / UL 50E	Type 12 / 4 / 4X
Ambient temperature limits	-40 °C ... +125 °C
Mechanical life (cycles)	≥ 500

Item	Description	Side entry	Top entry	Entry	Dimension
	Hoods, 2 levers and gasket, top entry		MLV 10 G25	M25	
	Hoods, 2 levers and gasket, top entry, high construction, with metal adapter		MLAV 10 G25 MLAV 10 G32 MLAV 10 G40	M25 M32 M40	
	Hoods, 2 levers and gasket, side or top entry, high construction To be used only with a complete cable gland	MLFO 10 G40	MLFV 10 G25 MLFV 10 G32 MLFV 10 G40	M25 M32 M40	

Inserts size 57.27	Poles	Pages	Inserts size 57.27	Poles	Pages
CNE	16 A	10 + ☉	CMCE / CMSH	16 A	3 + 2 (aux.) + ☉
CCE	16 A	10 + ☉	CX	40 A/10 A	8/24 + ☉
CSH / JSH S	16 A	10 + ☉			
CSHT	16 A	10 + ☉			
CQE / CQEY	16 A	18 + ☉			
CDD	10 A	42 + ☉			
CDSH	10 A	18 + ☉	MIXO Modular Inserts		Pages
CSS	16 A	10 + ☉	MIXO modules		C.12-93
			CX 03 T (3-slot sized MIXO frames)		C.93

Complete with:



Hoods
Page [E.57](#) [E.61](#)




Covers
Page [E.60](#)

IL-BRID series

Housings and covers – 1 lever – with gasket


size **77.27**


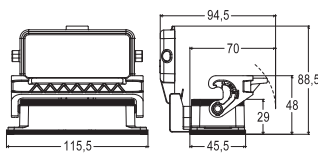

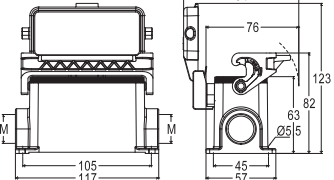

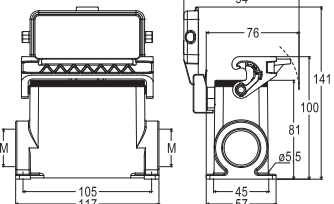


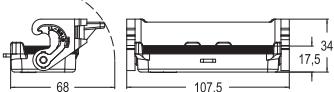
Heavy-Duty Applications 

CE UK

EN 60529	IP65 / IP66 / IP69
UL 50 / UL 50E	Type 12 / 4 / 4X
Ambient temperature limits	-40 °C ... +125 °C
Mechanical life (cycles)	≥ 500

 (pending CQC)

 ECBT2.E115072 | ECBT8.E115072

Item	Description	Part No.	With cover	Entry	Dimension
	Bulkhead mounting housings, 1 lever and gasket, with or without metal cover	CLI 16 L	CLI 16 LS		
	Surface mounting housings, 1 lever and gasket, with or without metal cover	MLP 16 L25 MLP 16 L225	MLP 16 LS25 MLP 16 LS225	M25 M25 × 2	
	Surface mounting housings, 1 lever and gasket, with or without metal cover high construction	MLAP 16 L32 MLAP 16 L232 MLAP 16 L40 MLAP 16 L240	MLAP 16 LS32 MLAP 16 LS232 MLAP 16 LS40 MLAP 16 LS240	M32 M32 × 2 M40 M40 × 2	
	Covers, 1 lever and gasket For enclosures with 2 pegs without gasket with loop for hoods 	CLC 16 LG			

IL-BRID
E

Inserts size 77.27	Poles	Pages	Inserts size 77.27	Poles	Pages	MIXO Modular Inserts	Pages
CNE 16 A	16 + ⊕	B.40	CP / CPY 35 A	6 + ⊕	B.112-114	MIXO modules	C.12-93
CCE 16 A	16 + ⊕	B.46	CSS 16 A	16 + ⊕	B.120	CX 04 T (4-slot sized MIXO frames)	C.93
CSH / JSH S 16 A	16 + ⊕	B.54-60	CT / CTSE* 16 A	16 + ⊕	B.128-132		
CSHT 16 A	16 + ⊕	B.67	CT / CTS* 10 A	40 + ⊕	B.138-140		
CQE / CQEY 16 A	32 + ⊕	B.74-84	CMCE / CMSH 16 A	6 + 2 (aux.) + ⊕	B.145-150		
CQEE 16 A	40 + ⊕	B.78	CX / CXC 80 A/16 A	4/0, 4/2 + ⊕	B.158-160		
CD 10 A	40 + ⊕	B.90	CX 40 A/10 A	6/12, 6/36, 9/42 and 12/2 + ⊕	B.163-164 168-169		
CDD 10 A	72 + ⊕	B.94					
CDSH 10 A	27 + ⊕	B.104					

*can be used only in bulkhead mounting housings

Complete with:



Hoods
Page [E.63](#)




Covers
Page [E.68](#)

IL-BRID series

Hoods – 1 lever – with gasket

size 77.27


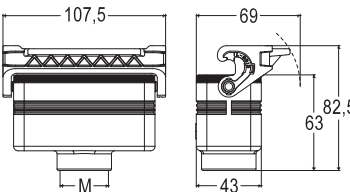

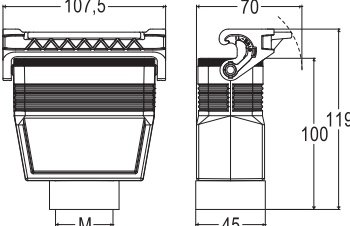

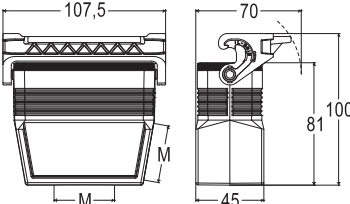
Heavy-Duty Applications 

CE UK

EN 60529	IP65 / IP66 / IP69
UL 50 / UL 50E	Type 12 / 4 / 4X
Ambient temperature limits	-40 °C ... +125 °C
Mechanical life (cycles)	≥ 500

 (pending CQC)

 ECBT2.E115072 | ECBT8.E115072

Item	Description	Side entry	Top entry	Entry	Dimension
	Hoods, 1 lever and gasket, top entry		MLV 16 LG32	M32	
	Hoods, 1 lever and gasket, top entry, high construction, with metal adapter		MLAV 16 LG25 MLAV 16 LG32 MLAV 16 LG40	M25 M32 M40	
	Hoods, 1 lever and gasket, side or top entry, high construction To be used only with a complete cable gland	MLFO 16 LG40	MLFV 16 LG25 MLFV 16 LG32 MLFV 16 LG40	M25 M32 M40	

IL-BRID

E

Inserts size 77.27	Poles	Pages	Inserts size 77.27	Poles	Pages	MIXO Modular Inserts	Pages
CNE	16 A	16 + ☉ B.40	CP / CPY	35 A	6 + ☉ B.112,114	MIXO modules	C.12-93
CCE	16 A	16 + ☉ B.46	CSS	16 A	16 + ☉ B.120	CX 04 T (4-slot sized MIXO frames)	C.95
CSH / JSH S	16 A	16 + ☉ B.54,60	CMCE / CMSH	16 A	6 + 2 (aux.) + ☉ B.145,150		
CSHT	16 A	16 + ☉ B.67	CX / CXC	80 A/16 A	4/0, 4/2 + ☉ B.158-160		
CQE / CQEY	16 A	32 + ☉ B.74,84	CX	40 A/10 A	6/12, 6/36, 9/42 and 12/2 + ☉ B.163-164, 168-169		
CQEE	16 A	40 + ☉ B.78					
CD	10 A	40 + ☉ B.90					
CDD	10 A	72 + ☉ B.94					
CDSH	10 A	27 + ☉ B.104					

Complete with:



Hoods
Page E.63




Covers
Page E.68

IL-BRID series

Housings and covers – 2 levers – with gasket


size **77.27**


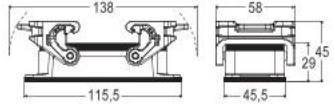

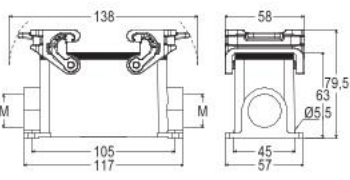

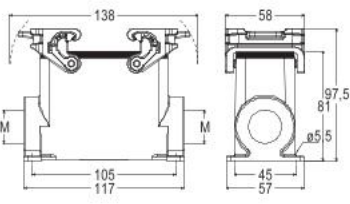


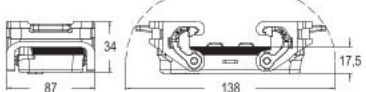
Heavy-Duty Applications 

CE UK CA

EN 60529	IP65 / IP66 / IP69
UL 50 / UL 50E	Type 12 / 4 / 4X
Ambient temperature limits	-40 °C ... +125 °C
Mechanical life (cycles)	≥ 500

 (pending CQC)

 ECBT2.E115072 | ECBT8.E115072

Item	Description	Part No.	Entry	Dimension
	Bulkhead mounting housings, 2 levers and gasket	CLI 16		
	Surface mounting housings, 2 levers and gasket	MLP 16.25 MLP 16.225	M25 M25 × 2	
	Surface mounting housings, 2 levers and gasket, high construction To be used only with a complete cable gland	MLAP 16.25 MLAP 16.225 MLAP 16.32 MLAP 16.232 MLAP 16.40 MLAP 16.240	M25 M25 × 2 M32 M32 × 2 M40 M40 × 2	
	Covers, 2 levers and gasket For enclosures with 4 pegs without gasket with loop for hoods 	CLC 16 G		

IL-BRID
E

Inserts size 77.27	Poles	Pages	Inserts size 77.27	Poles	Pages	MIXO Modular Inserts	Pages
CNE 16 A	16 + ⊕	3.40	CP / CPY 35 A	6 + ⊕	3.112-114	MIXO modules	3.12-93
CCE 16 A	16 + ⊕	3.46	CSS 16 A	16 + ⊕	3.120	CX 04 T (4-slot sized MIXO frames)	3.93
CSH / JSH S 16 A	16 + ⊕	3.54-60	CT / CTSE* 16 A	16 + ⊕	3.128-132		
CSHT 16 A	16 + ⊕	3.67	CT / CTS* 10 A	40 + ⊕	3.138-140		
CQE / CQEQ 16 A	32 + ⊕	3.74-84	CMCE / CMSH 16 A	6 + 2 (aux.) + ⊕	3.148-150		
CQEE 16 A	40 + ⊕	3.78	CX / CXC 80 A/16 A	4/0, 4/2 + ⊕	3.158-160		
CD 10 A	40 + ⊕	3.90	CX 40 A/10 A	6/12, 6/36, 9/42 and 12/2 + ⊕	3.163-164 168-169		
CDD 10 A	72 + ⊕	3.94					
CDSH 10 A	27 + ⊕	3.104					

*can be used only in bulkhead mounting housings

Complete with:


 **Hoods**
Page [E.68](#), [69](#)

 **Covers**
Page [E.68](#)

IL-BRID series

Hoods – 2 levers – with gasket

size 77.27


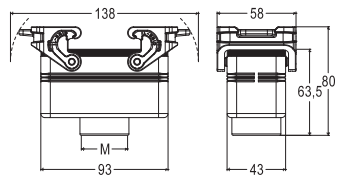

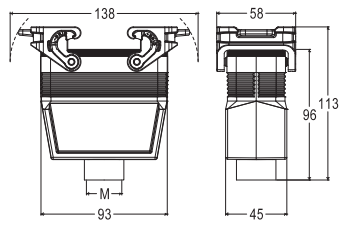

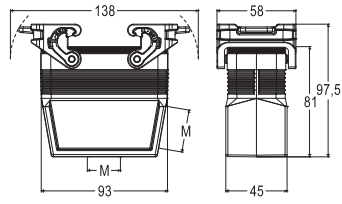
Heavy-Duty Applications 

CE UK

EN 60529	IP65 / IP66 / IP69
UL 50 / UL 50E	Type 12 / 4 / 4X
Ambient temperature limits	-40 °C ... +125 °C
Mechanical life (cycles)	≥ 500

 (pending CQC)

 ECBT2.E115072 | ECBT8.E115072

Item	Description	Side entry	Top entry	Entry	Dimension
	Hoods, 2 levers and gasket, top entry		MLV 16 G32	M32	
	Hoods, 2 levers and gasket, top entry, high construction, with metal adapter		MLAV 16 G25 MLAV 16 G32 MLAV 16 G40	M25 M32 M40	
	Hoods, 2 levers and gasket, side or top entry, high construction To be used only with a complete cable gland	MLFO 16 G40	MLFV 16 G25 MLFV 16 G32 MLFV 16 G40	M25 M32 M40	

IL-BRID

E

Inserts size 77.27	Poles	Pages	Inserts size 77.27	Poles	Pages	MIXO Modular Inserts	Pages
CNE 16 A	16 + ⊕	B.40	CP / CPY 35 A	6 + ⊕	B.112 / B.114	MIXO modules	C.12-93
CCE 16 A	16 + ⊕	B.46	CSS 16 A	16 + ⊕	B.120	CX 04 T (4-slot sized MIXO frames)	C.95
CSH / JSH S 16 A	16 + ⊕	B.54 / B.60	CMCE / CMSH 16 A	6 + 2 (aux.) + ⊕	B.145 / B.150		
CSHT 16 A	16 + ⊕	B.67	CX / CXC 80 A/16 A	4/0, 4/2 + ⊕	B.158-160		
CQE / CQEY 16 A	32 + ⊕	B.74 / B.84	CX 40 A/10 A	6/12, 6/36, 9/42 and 12/2 + ⊕	B.163-164 / B.168-169		
CQEE 16 A	40 + ⊕	B.78					
CD 10 A	40 + ⊕	B.90					
CDD 10 A	72 + ⊕	B.94					
CDSH 10 A	27 + ⊕	B.104					

Complete with:



Hoods
Page [E.68](#) / [E.69](#)



Covers
Page [E.68](#)

IL-BRID series

Housings and covers – 1 lever – with gasket

size **104.27**

Heavy-Duty Applications


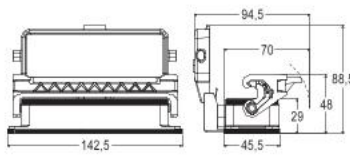

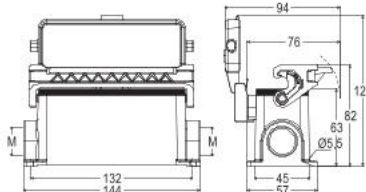

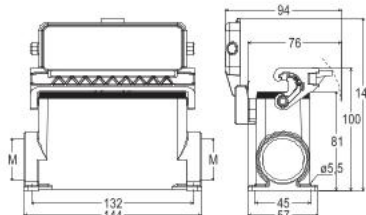


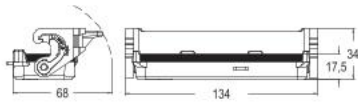


CE UK

EN 60529	IP65 / IP66 / IP69
UL 50 / UL 50E	Type 12 / 4 / 4X
Ambient temperature limits	-40 °C ... +125 °C
Mechanical life (cycles)	≥ 500

DNV VERITAS (pending CQC)

CAIUS ECBT2.E115072 | ECBT8.E115072

Item	Description	Part No.	With cover	Entry	Dimension
	Bulkhead mounting housings, 1 lever and gasket, with or without metal cover	CLI 24 L	CLI 24 LS		
	Surface mounting housings, 1 lever and gasket, with or without metal cover	MLP 24 L25 MLP 24 L225	MLP 24 LS25 MLP 24 LS225	M25 M25 × 2	
	Surface mounting housings, 1 lever and gasket, with or without metal cover high construction	MLAP 24 L32 MLAP 24 L232 MLAP 24 L40 MLAP 24 L240	MLAP 24 LS32 MLAP 24 LS232 MLAP 24 LS40 MLAP 24 LS240	M32 M32 × 2 M40 M40 × 2	
	Covers, 1 lever and gasket For enclosures with 2 pegs without gasket with loop for hoods 	CLC 24 LG			

IL-BRID
E

Inserts size 104.27	Poles	Pages	Inserts size 104.27	Poles	Pages	MIXO Modular Inserts	Pages	
CNE 16 A	24 + ⊕	3.41	CSS 16 A	24 + ⊕	3.121	MIXO modules	3.12-93	
CCE 16 A	24 + ⊕	3.47	CT / CTSE* 16 A	24 + ⊕	3.129 3.133	CX 06 T (6-slot sized MIXO frames)	3.93	
CSH / JSH S 16 A	24 + ⊕	3.55 3.71	CT / CTS* 10 A	64 + ⊕	3.139 3.141			
CSHT 16 A	24 + ⊕	3.68	CMCE / CMSH 16 A	10 + 2 (aux.) + ⊕	3.146 3.151			
CQE / CQEY 16 A	46 + ⊕	3.75 3.83	CX 100 A/16 A	8/0 and 6/6 + ⊕	3.156-157			
CQEE 16 A	64 + ⊕	3.79	CX / CXC 80 A/16 A	4/8 + ⊕	3.161-162			
CD 10 A	64 + ⊕	3.91	*can be used only in bulkhead mounting housings					
CDD 10 A	108 + ⊕	3.97						
CDSH 10 A	42 + ⊕	3.103						

Complete with:



Hoods
Page [E.71](#)



Covers
Page [E.76](#)

IL-BRID series

Hoods – 1 lever – with gasket

size 104.27

Heavy-Duty Applications

CE UK

(pending CQC)

ECBT2.E115072 | ECBT8.E115072

EN 60529	IP65 / IP66 / IP69
UL 50 / UL 50E	Type 12 / 4 / 4X
Ambient temperature limits	-40 °C ... +125 °C
Mechanical life (cycles)	≥ 500

Item	Description	Side entry	Top entry	Entry	Dimension
	Hoods, 1 lever and gasket, top entry		MLV 24 LG32	M32	
	Hoods, 1 lever and gasket, top entry, high construction, with metal adapter		MLAV 24 LG25 MLAV 24 LG32 MLAV 24 LG40	M25 M32 M40	
	Hoods, 1 lever and gasket, side or top entry, high construction To be used only with a complete cable gland	MLFO 24 LG40	MLFV 24 LG25 MLFV 24 LG32 MLFV 24 LG40	M25 M32 M40	

IL-BRID

E

Inserts size 104.27	Poles	Pages	Inserts size 104.27	Poles	Pages	MIXO Modular Inserts	Pages
CNE	16 A	24 + ☉ B.41	CSS	16 A	24 + ☉ B.121	MIXO modules	C.12-93
CCE	16 A	24 + ☉ B.47	CMCE / CMSH	16 A	10 + 2 (aux.) + ☉ B.146,151	CX 06 T (6-slot sized MIXO frames)	C.95
CSH / JSH S	16 A	24 + ☉ B.55,61	CX	100 A/16 A	8/0 and 6/6 + ☉ B.156-157		
CSHT	16 A	24 + ☉ B.68	CX / CXC	80 A/16 A	4/8 + ☉ B.161-162		
CQE / CQEY	16 A	46 + ☉ B.75,85					
CQEE	16 A	64 + ☉ B.79					
CD	10 A	64 + ☉ B.91					
CDD	10 A	108 + ☉ B.97					
CDSH	10 A	42 + ☉ B.105					

Complete with:



Hoods
Page E.71



Covers
Page E.76

IL-BRID series

Housings and covers – 2 levers – with gasket

size **104.27**

Heavy-Duty Applications


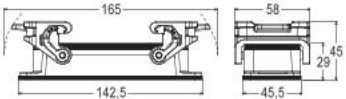

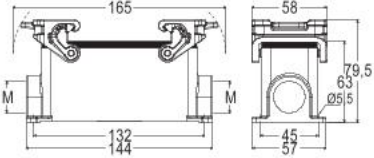

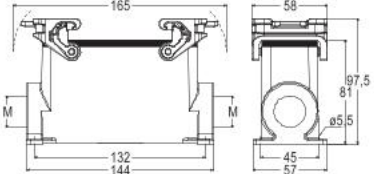
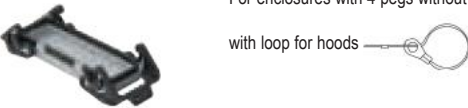

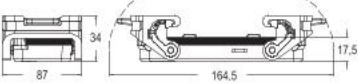


CE UK CA

EN 60529	IP65 / IP66 / IP69
UL 50 / UL 50E	Type 12 / 4 / 4X
Ambient temperature limits	-40 °C ... +125 °C
Mechanical life (cycles)	≥ 500

DNV VERITAS (pending CQC)

CBUS ECBT2.E115072 | ECBT8.E115072

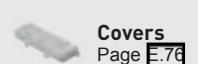
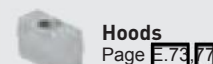
Item	Description	Part No.	Entry	Dimension
	Bulkhead mounting housings, 2 levers and gasket	CLI 24		
	Surface mounting housings, 2 levers and gasket	MLP 24.25 MLP 24.225	M25 M25 × 2	
	Surface mounting housings, 2 levers and gasket, high construction To be used only with a complete cable gland	MLAP 24.25 MLAP 24.225 MLAP 24.32 MLAP 24.232 MLAP 24.40 MLAP 24.240	M25 M25 × 2 M32 M32 × 2 M40 M40 × 2	
	Covers, 2 levers and gasket For enclosures with 4 pegs without gasket with loop for hoods 	CLC 24 G		

IL-BRID

E

Inserts size 104.27	Poles	Pages	Inserts size 104.27	Poles	Pages	MIXO Modular Inserts	Pages	
CNE 16 A	24 + ⊕	B.41	CSS 16 A	24 + ⊕	3.121	MIXO modules	C.12-93	
CCE 16 A	24 + ⊕	B.47	CT / CTSE* 16 A	24 + ⊕	3.129 133	CX 06 T (6-slot sized MIXO frames)	C.93	
CSH / JSH S 16 A	24 + ⊕	B.55 51	CT / CTS* 10 A	64 + ⊕	3.139 141			
CSHT 16 A	24 + ⊕	B.68	CMCE / CMSH 16 A	10 + 2 (aux.) + ⊕	3.146 151			
CQE / CQEY 16 A	46 + ⊕	B.75 35	CX 100 A/16 A	8/0 and 6/6 + ⊕	3.156-157			
CQEE 16 A	64 + ⊕	B.79	CX / CXC 80 A/16 A	4/8 + ⊕	3.161-162			
CD 10 A	64 + ⊕	B.91	*can be used only in bulkhead mounting housings					
CDD 10 A	108 + ⊕	B.97						
CDSH 10 A	42 + ⊕	B.103						

Complete with:



IL-BRID series

Hoods - 2 levers - with gasket

size 104.27

Heavy-Duty
Applications


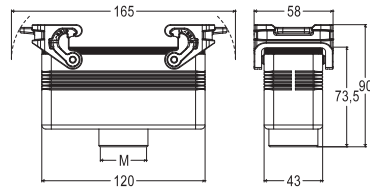

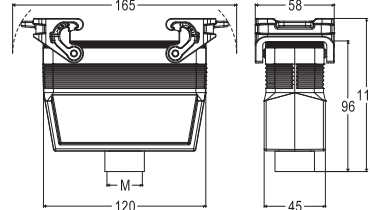

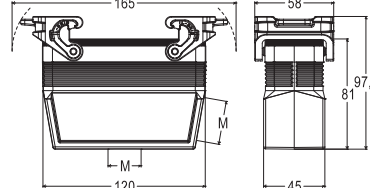


CE UK

DNV (pending CQC)

CEC® ECBT2.E115072 | ECBT8.E115072

EN 60529	IP65 / IP66 / IP69
UL 50 / UL 50E	Type 12 / 4 / 4X
Ambient temperature limits	-40 °C ... +125 °C
Mechanical life (cycles)	≥ 500

Item	Description	Side entry	Top entry	Entry	Dimension
	Hoods, 2 levers and gasket, top entry		MLV 24 G32	M32	
	Hoods, 2 levers and gasket, top entry, high construction, with metal adapter		MLAV 24 G25 MLAV 24 G32 MLAV 24 G40	M25 M32 M40	
	Hoods, 2 levers and gasket, side or top entry, high construction To be used only with a complete cable gland	MLFO 24 G40	MLFV 24 G25 MLFV 24 G32 MLFV 24 G40	M25 M32 M40	

IL-BRID

E

Inserts size 104.27	Poles	Pages	Inserts size 104.27	Poles	Pages	MIXO Modular Inserts	Pages
CNE	16 A	24 + ☉	B.41	CSS	16 A	24 + ☉	B.121
CCE	16 A	24 + ☉	B.47	CMCE / CMSH	16 A	10 + 2 (aux.) + ☉	B.146-151
CSH / JSH S	16 A	24 + ☉	B.55-61	CX	100 A/16 A	8/0 and 6/6 + ☉	B.156-157
CSHT	16 A	24 + ☉	B.68	CX / CXC	80 A/16 A	4/8 + ☉	B.161-162
CQE / CQEY	16 A	46 + ☉	B.75-83				
CQEE	16 A	64 + ☉	B.79				
CD	10 A	64 + ☉	B.91				
CDD	10 A	108 + ☉	B.97				
CDSH	10 A	42 + ☉	B.103				

Complete with:



Hoods
Page [E.73](#) [E.77](#)



Covers
Page [E.76](#)

IL-BRID series

Hoods – 1 lever – without gasket

size **44.27**

Heavy-Duty Applications


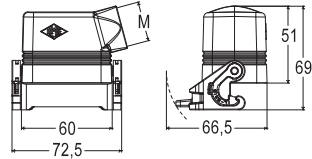

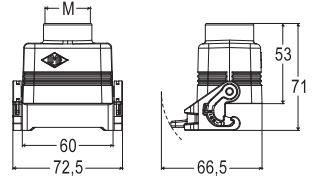


CE UK CA

EN 60529	IP65 / IP66 / IP69
UL 50 / UL 50E	Type 12 / 4 / 4X
Ambient temperature limits	-40 °C ... +125 °C
Mechanical life (cycles)	≥ 500

DNV (pending CQC)

ECBT2.E115072 | ECBT8.E115072

Item	Description	Part No.	Entry	Dimension
	Hoods, 1 lever, without gasket, side entry	MLO 06 LX20 MLO 06 LX25	M20 M25	
	Hoods, 1 lever, without gasket, top entry	MLV 06 LX20 MLV 06 LX25	M20 M25	

Inserts size 44.27	Poles	Pages	MIXO Modular Inserts	Pages
CNE	16 A 6 + ⊕	B.38	MIXO modules	C.12-93
CCE	16 A 6 + ⊕	B.44	CX 02 T (2-slot sized MIXO frames)	C.95
CSH / JSH S	16 A 6 + ⊕	B.52,58		
CQE / CQEY	16 A 10 + ⊕	B.72,82		
CDD	10 A 24 + ⊕	B.94		
CDSH / CDSH NC	10 A 9 and 6 + ⊕	B.102,108		
CSS	16 A 6 + ⊕	B.118		

Complete with:




Housings
Page E.50



Covers
Page E.52


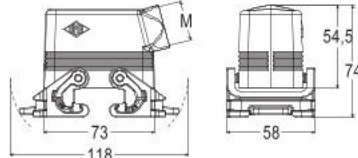

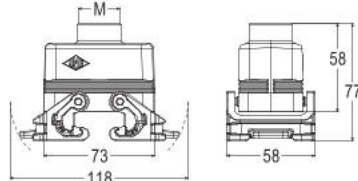

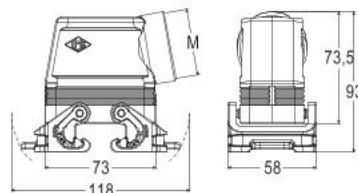

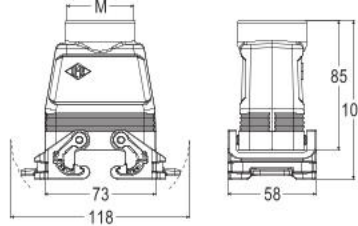
IL-BRID series

Hoods - 2 levers - without gasket

size **57.27**
Heavy-Duty Applications

CE UK
 (pending CQC)

CALUS ECBT2.E115072 | ECBT8.E115072

EN 60529	IP65 / IP66 / IP69
UL 50 / UL 50E	Type 12 / 4 / 4X
Ambient temperature limits	-40 °C ... +125 °C
Mechanical life (cycles)	≥ 500

Item	Description	Part No.	Entry	Dimension
	Hoods, 2 levers, without gasket, side entry	MLO 10 X20 MLO 10 X25	M20 M25	
	Hoods, 2 levers, without gasket, top entry	MLV 10 X20 MLV 10 X25	M20 M25	
	Hoods, 2 levers, without gasket, side entry, high construction	MLAO 10 X32 MLAO 10 X40	M32 M40	
	Hoods, 2 levers, without gasket, top entry, high construction	MLAV 10 X32 MLAV 10 X40	M32 M40	

IL-BRID

E

Inserts size 57.27	Poles	Pages	Inserts size 57.27	Poles	Pages
CNE	16 A	10 + ☉	CMCE / CMSH	16 A	3 + 2 (aux.) + ☉
CCE	16 A	10 + ☉	CX	40 A/10 A	8/24 + ☉
CSH / JSH S	16 A	10 + ☉			
CSHT	16 A	10 + ☉			
CQE / CQEY	16 A	18 + ☉			
CDD	10 A	42 + ☉	MIXO Modular Inserts		Pages
CDSH	10 A	18 + ☉	MIXO modules		C.12-93
CSS	16 A	10 + ☉	CX 03 T (3-slot sized MIXO frames)		C.93

Complete with:


Housings
Page **E.58**

Covers
Page **E.60**

IL-BRID series

Hoods – 2 levers – without gasket

size **77.27**

Heavy-Duty Applications


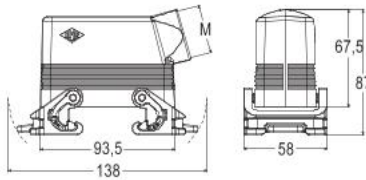

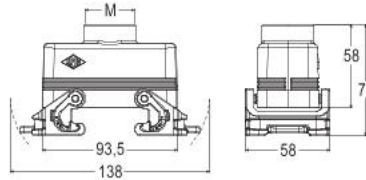

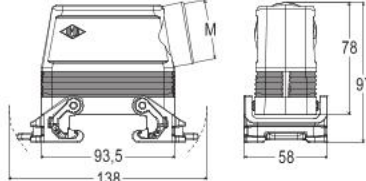

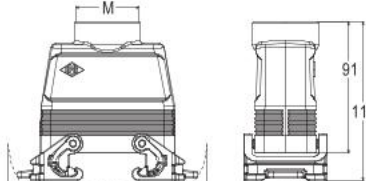


CE UK CA

EN 60529	IP65 / IP66 / IP69
UL 50 / UL 50E	Type 12 / 4 / 4X
Ambient temperature limits	-40 °C ... +125 °C
Mechanical life (cycles)	≥ 500

DNV VERITAS (pending CQC)

CEBUS ECBT2.E115072 | ECBT8.E115072


Item	Description	Part No.	Entry	Dimension
	Hoods, 2 levers, without gasket, side entry	MLO 16 X25 MLO 16 X32	M25 M32	
	Hoods, 2 levers, without gasket, top entry	MLV 16 X25 MLV 16 X32	M25 M32	
	Hoods, 2 levers, without gasket, side entry, high construction	MLAO 16 X32 MLAO 16 X40	M32 M40	
	Hoods, 2 levers, without gasket, top entry, high construction	MLAV 16 X32 MLAV 16 X40	M32 M40	


IL-BRID

E

Inserts size 77.27	Poles	Pages	Inserts size 77.27	Poles	Pages	MIXO Modular Inserts	Pages
CNE 16 A	16 + ⊕	B.40	CP / CPY 35 A	6 + ⊕	B.112-114	MIXO modules	C.12-93
CCE 16 A	16 + ⊕	B.46	CSS 16 A	16 + ⊕	B.120	CX 04 T (4-slot sized MIXO frames)	C.93
CSH / JSH S 16 A	16 + ⊕	B.54-60	CMCE / CMSH 16 A	6 + 2 (aux.) + ⊕	B.145-150		
CSHT 16 A	16 + ⊕	B.67	CX / CXC 80 A/16 A	4/0, 4/2 + ⊕	B.158-160		
CQE / CQEY 16 A	32 + ⊕	B.74-84	CX 40 A/10 A	6/12, 6/36, 9/42 and 12/2 + ⊕	B.163-164, 168-169		
CQEE 16 A	40 + ⊕	B.78					
CD 10 A	40 + ⊕	B.90					
CDD 10 A	72 + ⊕	B.94					
CDSH 10 A	27 + ⊕	B.104					


Complete with:

 **Housings**
Page **E.66**

 **Covers**
Page **E.68**

IL-BRID series

Hoods - 2 levers - without gasket


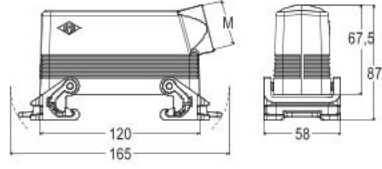

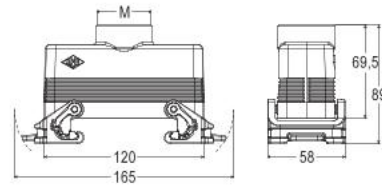

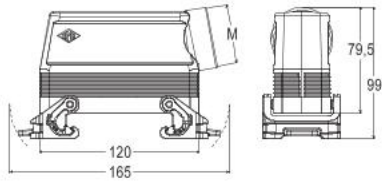

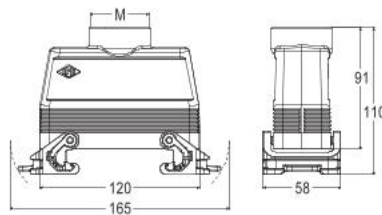
size **104.27**Heavy-Duty
Applications 

CE UK

 (pending CQC)

CIRIUS ECBT2.E115072 | ECBT8.E115072

EN 60529	IP65 / IP66 / IP69
UL 50 / UL 50E	Type 12 / 4 / 4X
Ambient temperature limits	-40 °C ... +125 °C
Mechanical life (cycles)	≥ 500

Item	Description	Part No.	Entry	Dimension
	Hoods, 2 levers, without gasket, side entry	MLO 24 X25 MLO 24 X32	M25 M32	
	Hoods, 2 levers, without gasket, top entry	MLV 24 X25 MLV 24 X32	M25 M32	
	Hoods, 2 levers, without gasket, side entry, high construction	MLAO 24 X32 MLAO 24 X40	M32 M40	
	Hoods, 2 levers, without gasket, top entry, high construction	MLAV 24 X32 MLAV 24 X40	M32 M40	

Inserts size 104.27	Poles	Pages	Inserts size 104.27	Poles	Pages	MIXO Modular Inserts	Pages
CNE	16 A	24 + ⊕	CSS	16 A	24 + ⊕	MIXO modules	3.12-93
CCE	16 A	24 + ⊕	CMCE / CMSH	16 A	10 + 2 (aux.) + ⊕	CX 06 T (6-slot sized MIXO frames)	3.95
CSH / JSH S	16 A	24 + ⊕	CX	100 A/16 A	8/0 and 6/6 + ⊕		
CSHT	16 A	24 + ⊕	CX / CXC	80 A/16 A	4/8 + ⊕		
CQE / CQEY	16 A	46 + ⊕					
CQEE	16 A	64 + ⊕					
CD	10 A	64 + ⊕					
CDD	10 A	108 + ⊕					
CDSH	10 A	42 + ⊕					

Complete with:

Housings
Page E.74Covers
Page E.76

Panel cut-out drawings

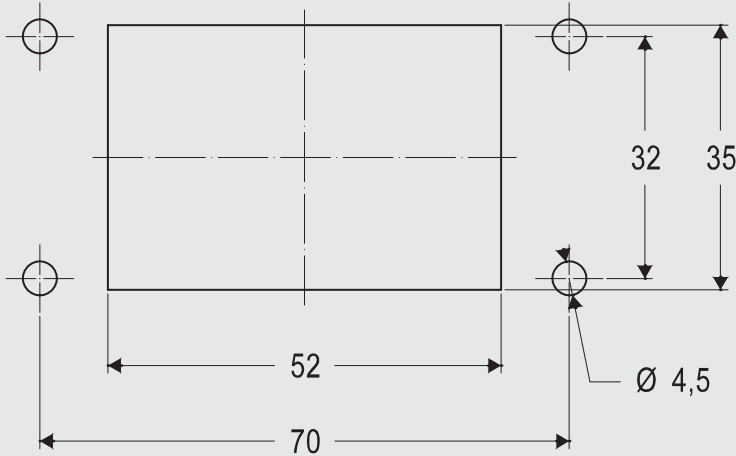
For IL-BRID series bulkhead mounting housings

To guarantee the declared IP degree of protection of the housings reported in this catalogue, according to EN IEC 60529 or to the relevant Type rating per ANSI/UL 50 and 50E (for those products bearing approval to those ratings), the surface of the mounting panel must meet the following requirements (definitions are provided in ISO 4287 standard):

Waviness $Wt \leq 0,2$ mm over a distance of 200 mm (measured on the panel without load)
Roughness $Ra \leq 16$ μ m

Scale 1:1

Size 44.27



Required screws: 4
Screws size: M4
Recommended torque:
 0,8 – 1,2 Nm / 7.1 – 10.6 lb.in

Size 57.27



Required screws: 4
Screws size: M4
Recommended torque:
 0,8 – 1,2 Nm / 7.1 – 10.6 lb.in

Notes: The values of tightening torque indicated above are just recommended values, that must be related – by the designer of the final application – to the resistance class of the screws (not included), with the assumption that the mounting panel is sufficiently rigid (stiff). If the deflection of the panel, under the effect of tightening the screws, is greater than 0,7 mm over a distance of 100 mm, it is

necessary to use the counter-flanges mentioned in our catalogue or the special flange gaskets available upon request (please contact our Sales Department).

Panel cut-out drawings

For IL-BRID series bulkhead mounting housings

To guarantee the declared IP degree of protection of the housings reported in this catalogue, according to EN IEC 60529 or to the relevant Type rating per ANSI/UL 50 and 50E (for those products bearing approval to those ratings), the surface of the mounting panel must meet the following requirements (definitions are provided in ISO 4287 standard):

Waviness $W_t \leq 0,2$ mm over a distance of 200 mm
(measured on the panel without load)

Roughness $R_a \leq 16$ μm

Scale 1:1

Size 77.27



Required screws: 4
Screws size: M4
Recommended torque:
0,8 – 1,2 Nm / 7.1 – 10.6 lb.in

Size 104.27



Required screws: 4
Screws size: M4
Recommended torque:
0,8 – 1,2 Nm / 7.1 – 10.6 lb.in

Notes: The values of tightening torque indicated above are just recommended values, that must be related – by the designer of the final application – to the resistance class of the screws (not included), with the assumption that the mounting panel is sufficiently rigid (stiff). If the deflection of the panel, under the effect of tightening the screws, is greater than 0,7 mm over a distance of 100 mm, it is

necessary to use the counter-flanges mentioned in our catalogue or the special flange gaskets available upon request (please contact our Sales Department).



JEI®-P enclosures



Standard enclosures with JEI®-P levers

The JEI®-P enclosure series features a fully thermoplastic locking lever, whose design is derived from the IL-BRID locking lever(s).

The series covers the standard enclosure sizes 44.27, 57.27, 77.27, and 104.27 with single and double levers, resulting in a versatile and ergonomic space-saving solution, allowing multiple installations side by side.

SUM-UP

JP – JMP series

- > Made of die cast aluminium alloy
- > Gaskets in anti-aging, oil-resistant, grease-resistant and fuel resistant vinyl nitrile elastomer
- > JEP®-P locking device in self-extinguishing thermoplastic material
- > Ambient temperature range: -40 °C / +125 °C

≡ Markings and Approvals

- CE and UK markings, EAC not applicable
- UL certified for USA and Canada for Type 12, 4 and 4X degrees of protection (enclosure type ratings, equivalent to NEMA rating)
- IP65 degree of protection
- RoHS: compliant

FOCUS

Levers and technology

Single-block locking lever in self-extinguishing thermoplastic material with enhanced ergonomics and reduced dimension, ideal for basic requirements and less demanding environments.



- ▶ Space saving design for a compact footprint



- ▶ Thermoplastic lever
- ▶ Contour of lever hooks adapted to larger Ø pegs


- ▶ V-shaped ribs to improve stiffness of handles on enclosures with single lever



JEI®-P series

Housings and hoods – 1 lever – with gasket


size **44.27**


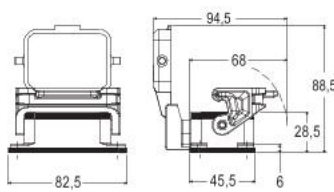

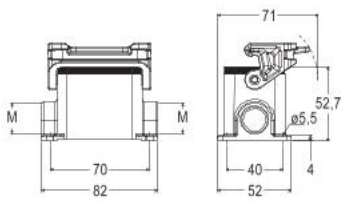

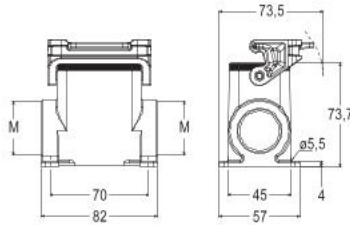

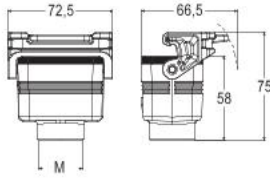

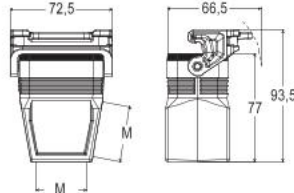
Heavy-Duty Applications 

CE UK CA

EN 60529	IP65
UL 50 / UL 50E	Type 12 / 4 / 4X
Ambient temperature limits	-40 °C ... +125 °C
Mechanical life (cycles)	≥ 500

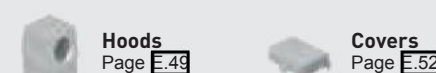
 (pending CQC)

 ECBT2.E115072 | ECBT8.E115072

Item	Description	Part No.	With cover	Entry	Dimension
	Bulkhead mounting housings, 1 lever and gasket, with or without metal cover	JPI 06 L	JPI 06 LS		
	Surface mounting housings, 1 lever and gasket	JMPP 06 L20 JMPP 06 L220		M20 M20 × 2	
	Surface mounting housings, 1 lever and gasket, high construction To be used only with a complete cable gland	JMPAP 06 L25 JMPAP 06 L225 JMPAP 06 L32 JMPAP 06 L232 JMPAP 06 L40 JMPAP 06 L240		M25 M25 × 2 M32 M32 × 2 M40 M40 × 2	
	Hoods, 1 lever and gasket, top entry		Top entry	JMPV 06 LG25	M25 
	Hoods, 1 lever and gasket, side or top entry, high construction To be used only with a complete cable gland		Side entry Top entry	JMPFV 06LG25 JMPFV 06LG32 JMPFO 06LG40 JMPFV 06LG40	M25 M32 M40 

Inserts size 44.27	Poles	Pages	MIXO Modular Inserts	Pages
CNE	16 A	6 + ⊕	MIXO modules	C.12-93
CCE	16 A	6 + ⊕	CX 02 T (2-slot sized MIXO frames)	C.95
CSH / JSH S	16 A	6 + ⊕		
CQE / CQEY	16 A	10 + ⊕		
CDD	10 A	24 + ⊕		
CDSH / CDSH NC	10 A	9 and 6 + ⊕		
CSS	16 A	6 + ⊕		
CT / CTSE*	16 A	6 + ⊕		


Complete with:



*can be used only in bulkhead mounting housings

JEI®-P series

Housings and hoods – 1 lever – with gasket


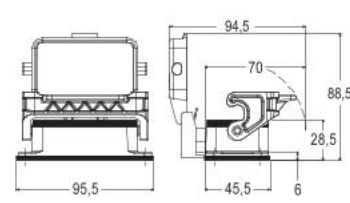

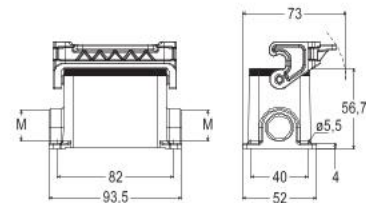

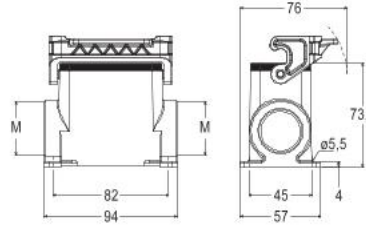

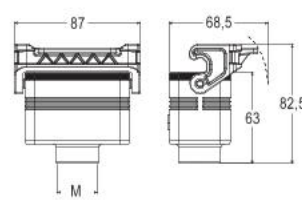

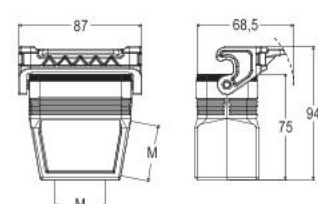
size **57.27**
Heavy-Duty Applications




EN 60529	IP65
UL 50 / UL 50E	Type 12 / 4 / 4X
Ambient temperature limits	-40 °C ... +125 °C
Mechanical life (cycles)	≥ 500

 (pending CQC)

 ECBT2.E115072 | ECBT8.E115072

Item	Description	Part No.	With cover	Entry	Dimension
	Bulkhead mounting housings, 1 lever and gasket, with or without metal cover	JPI 10 L	JPI 10 LS		
	Surface mounting housings, 1 lever and gasket	JMPP 10 L20 JMPP 10 L220		M20 M20 × 2	
	Surface mounting housings, 1 lever and gasket, high construction To be used only with a complete cable gland	JMPAP 10 L25 JMPAP 10 L225 JMPAP 10 L32 JMPAP 10 L232 JMPAP 10 L40 JMPAP 10 L240		M25 M25 × 2 M32 M32 × 2 M40 M40 × 2	
	Hoods, 1 lever and gasket, top entry		Top entry JMPV 10 LG25	M25	
	Hoods, 1 lever and gasket, side or top entry, high construction To be used only with a complete cable gland		Side entry Top entry JMPFV 10LG25 JMPFV 10LG32 JMPFO 10LG40 JMPFV 10LG40	M25 M32 M40	

Inserts size 57.27	Poles	Pages	Inserts size 57.27	Poles	Pages
CNE	16 A	10 + ⊕	CT / CTSE*	16 A	10 + ⊕
CCE	16 A	10 + ⊕	CMCE / CMSH	16 A	3 + 2 (aux.) + ⊕
CSH / JSH S	16 A	10 + ⊕	CX	40 A/10 A	8/24 + ⊕
CSHT	16 A	10 + ⊕			
CQE / CQEY	16 A	18 + ⊕			
CDD	10 A	42 + ⊕			
CDSH	10 A	18 + ⊕			
CSS	16 A	10 + ⊕			
			MIXO Modular Inserts		Pages
			MIXO modules		C.12-93
			CX 03 T (3-slot sized MIXO frames)		C.93

Complete with:



Hoods
Page [E.53](#)

Covers
Page [E.60](#)

JEI®-P series

Housings and hoods – 2 levers – with gasket

size **57.27**


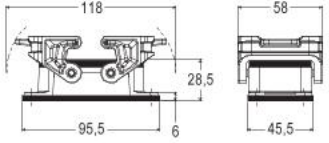

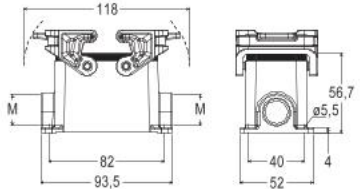

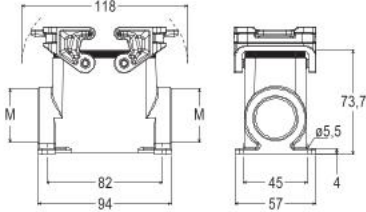

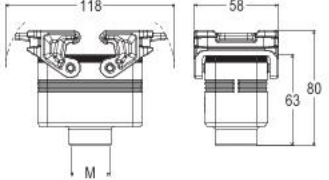

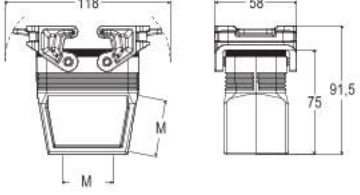
Heavy-Duty Applications 

CE UK

EN 60529	IP65
UL 50 / UL 50E	Type 12 / 4 / 4X
Ambient temperature limits	-40 °C ... +125 °C
Mechanical life (cycles)	≥ 500

 (pending CQC)

 ECBT2.E115072 | ECBT8.E115072

Item	Description	Part No.	Entry	Dimension
	Bulkhead mounting housings, 2 levers and gasket	JPI 10		
	Surface mounting housings, 2 levers and gasket	JMPP 10.20 JMPP 10.220	M20 M20 × 2	
	Surface mounting housings, 2 levers and gasket, high construction To be used only with a complete cable gland	JMPAP 10.25 JMPAP 10.225 JMPAP 10.32 JMPAP 10.232 JMPAP 10.40 JMPAP 10.240	M25 M25 × 2 M32 M32 × 2 M40 M40 × 2	
	Hoods, 2 levers and gasket, top entry	JMPV 10 G25	Top entry M25	
	Hoods, 2 levers and gasket, side or top entry, high construction To be used only with a complete cable gland	JMPFV 10 G25 JMPFV 10 G32 JMPFO 10 G40 JMPFV 10 G40	Side entry Top entry M25 M32 M40	

Inserts size 57.27	Poles	Pages	Inserts size 57.27	Poles	Pages
CNE	16 A	10 + ☉	CT / CTSE*	16 A	10 + ☉
CCE	16 A	10 + ☉	CMCE / CMSH	16 A	3 + 2 (aux.) + ☉
CSH / JSH S	16 A	10 + ☉	CX	40 A/10 A	8/24 + ☉
CSHT	16 A	10 + ☉			
CQE / CQEY	16 A	18 + ☉			
CDD	10 A	42 + ☉			
CDSH	10 A	18 + ☉			
CSS	16 A	10 + ☉			

*can be used only in bulkhead mounting housings

MIXO Modular Inserts	Pages
MIXO modules	C.12-93
CX 03 T (3-slot sized MIXO frames)	C.95

Complete with:



JEI®-P series

size **77.27**

Housings and hoods – 1 lever – with gasket

Heavy-Duty
Applications

CE UK

EN 60529	IP65
UL 50 / UL 50E	Type 12 / 4 / 4X
Ambient temperature limits	-40 °C ... +125 °C
Mechanical life (cycles)	≥ 500

(pending CQC)

ECBT2.E115072 | ECBT8.E115072

Item	Description	Part No.	With cover	Entry	Dimension
	Bulkhead mounting housings, 1 lever and gasket, with or without metal cover	JPI 16 L	JPI 16 LS		
	Surface mounting housings, 1 lever and gasket	JMPP 16 L25 JMPP 16 L225		M25 M25 × 2	
	Surface mounting housings, 1 lever and gasket, high construction To be used only with a complete cable gland	JMPAP 16 L25 JMPAP 16 L225 JMPAP 16 L32 JMPAP 16 L232 JMPAP 16 L40 JMPAP 16 L240		M25 M25 × 2 M32 M32 × 2 M40 M40 × 2	
	Hoods, 1 lever and gasket, top entry		Top entry	JMPV 16 LG32	M32
	Hoods, 1 lever and gasket, side or top entry, high construction To be used only with a complete cable gland		Side entry Top entry	JMPFV 16LG25 JMPFV 16LG32 JMPFO 16LG40 JMPFV 16LG40	M25 M32 M40

Inserts size 77.27	Poles	Pages	Inserts size 77.27	Poles	Pages	MIXO Modular Inserts	Pages
CNE	16 A	16 + ⊕	CP / CPY	35 A	6 + ⊕	MIXO modules	C.12-93
CCE	16 A	16 + ⊕	CSS	16 A	16 + ⊕	CX 04 T (4-slot sized MIXO frames)	D.95
CSH / JSH S	16 A	16 + ⊕	CT / CTSE*	16 A	16 + ⊕		
CSHT	16 A	16 + ⊕	CT / CTS*	10 A	40 + ⊕		
CQE / CQEY	16 A	32 + ⊕	CMCE / CMSH	16 A	6 + 2 (aux.) + ⊕		
CQEE	16 A	40 + ⊕	CX / CXC	80 A/16 A	4/0, 4/2 + ⊕		
CD	10 A	40 + ⊕	CX	40 A/10 A	6/12, 6/36, 9/42 and 12/2 + ⊕		
CDD	10 A	72 + ⊕					
CDSH	10 A	27 + ⊕					

*can be used only in bulkhead mounting housings

dimensions shown in mm are not binding and may be changed without notice

Complete with:

Hoods
Page E.63Covers
Page E.68

JEI®-P series

size **77.27**

Housings and hoods – 2 levers – with gasket

Heavy-Duty Applications



CE UK CA

EN 60529	IP65
UL 50 / UL 50E	Type 12 / 4 / 4X
Ambient temperature limits	-40 °C ... +125 °C
Mechanical life (cycles)	≥ 500

DNV VERITAS (pending CQC)

CEBUS ECBT2.E115072 | ECBT8.E115072

Item	Description	Part No.	Entry	Dimension
	Bulkhead mounting housings, 2 levers and gasket	JPI 16		
	Surface mounting housings, 2 levers and gasket	JMPP 16.25 JMPP 16.225	M25 M25 × 2	
	Surface mounting housings, 2 levers and gasket, high construction To be used only with a complete cable gland	JMPAP 16.25 JMPAP 16.225 JMPAP 16.32 JMPAP 16.232 JMPAP 16.40 JMPAP 16.240	M25 M25 × 2 M32 M32 × 2 M40 M40 × 2	
	Hoods, 2 levers and gasket, top entry	JMPV 16 G32	M32 Top entry	
	Hoods, 2 levers and gasket, side or top entry, high construction To be used only with a complete cable gland	JMPFV 16 G25 JMPFV 16 G32 JMPFO 16 G40 JMPFV 16 G40	M25 M32 M40 Side entry Top entry	

JEI®-P
E

Inserts size 77.27	Poles	Pages	Inserts size 77.27	Poles	Pages	MIXO Modular Inserts	Pages
CNE 16 A	16 + ⊕	3.40	CP / CPY 35 A	6 + ⊕	3.112 114	MIXO modules	3.12-93
CCE 16 A	16 + ⊕	3.46	CSS 16 A	16 + ⊕	3.120	CX 04 T (4-slot sized MIXO frames)	3.93
CSH / JSH S 16 A	16 + ⊕	3.54 30	CT / CTSE* 16 A	16 + ⊕	3.128 132		
CSHT 16 A	16 + ⊕	3.67	CT / CTS* 10 A	40 + ⊕	3.138 140		
CQE / CQEY 16 A	32 + ⊕	3.74 34	CMCE / CMSH 16 A	6 + 2 (aux.) + ⊕	3.145 150		
CQEE 16 A	40 + ⊕	3.78	CX / CXC 80 A/16 A	4/0, 4/2 + ⊕	3.158-160		
CD 10 A	40 + ⊕	3.90	CX 40 A/10 A	6/12, 6/36, 9/42 and 12/2 + ⊕	3.163-164 168-169		
CDD 10 A	72 + ⊕	3.94					
CDSH 10 A	27 + ⊕	3.104					

*can be used only in bulkhead mounting housings

Complete with:



Hoods
Page [E.63](#) [69](#)




Covers
Page [E.68](#)

JEI®-P series

size **104.27**

Housings and hoods – 1 lever – with gasket


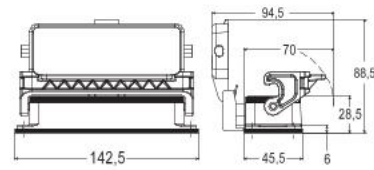

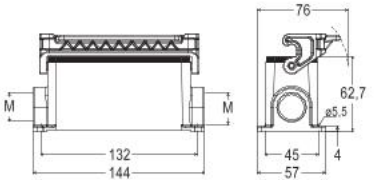

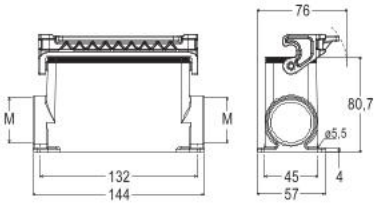

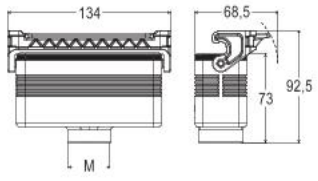

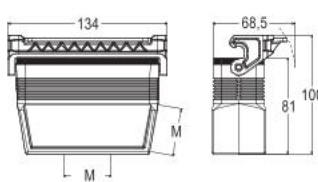
Heavy-Duty
Applications 

CE UK

EN 60529	IP65
UL 50 / UL 50E	Type 12 / 4 / 4X
Ambient temperature limits	-40 °C ... +125 °C
Mechanical life (cycles)	≥ 500

 (pending CQC)

 ECBT2.E115072 | ECBT8.E115072

Item	Description	Part No.	With cover	Entry	Dimension
	Bulkhead mounting housings, 1 lever and gasket, with or without metal cover	JPI 24 L	JPI 24 LS		
	Surface mounting housings, 1 lever and gasket	JMPP 24 L25 JMPP 24 L225		M25 M25 × 2	
	Surface mounting housings, 1 lever and gasket, high construction To be used only with a complete cable gland	JMPAP 24 L25 JMPAP 24 L225 JMPAP 24 L32 JMPAP 24 L232 JMPAP 24 L40 JMPAP 24 L240		M25 M25 × 2 M32 M32 × 2 M40 M40 × 2	
	Hoods, 1 lever and gasket, top entry		Top entry	JMPV 24 LG32	M32 
	Hoods, 1 lever and gasket, side or top entry, high construction To be used only with a complete cable gland		Side entry Top entry	JMPFV 24LG25 JMPFV 24LG32 JMPFO 24LG40 JMPFV 24LG40	M25 M32 M40 

Inserts size 104.27	Poles	Pages	Inserts size 104.27	Poles	Pages	MIXO Modular Inserts	Pages
CNE	16 A	24 + ⊕	B.41	CSS	16 A	24 + ⊕	3.121
CCE	16 A	24 + ⊕	B.47	CT / CTSE*	16 A	24 + ⊕	3.129 133
CSH / JSH S	16 A	24 + ⊕	B.55 61	CT / CTS*	10 A	64 + ⊕	3.139 141
CSHT	16 A	24 + ⊕	B.68	CMCE / CMSH	16 A	10 + 2 (aux.) + ⊕	3.148 151
CQE / CQEY	16 A	46 + ⊕	B.75 83	CX	100 A/16 A	8/0 and 6/6 + ⊕	3.156-157
CQEE	16 A	64 + ⊕	B.79	CX / CXC	80 A/16 A	4/8 + ⊕	3.161-162
CD	10 A	64 + ⊕	B.91	*can be used only in bulkhead mounting housings			
CDD	10 A	108 + ⊕	B.97				
CDSH	10 A	42 + ⊕	B.103				


Complete with:

Hoods
Page [E.71](#)Covers
Page [E.76](#)

JEI®-P series

Housings and hoods – 2 levers – with gasket

size **104.27**


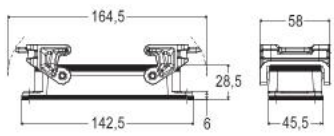

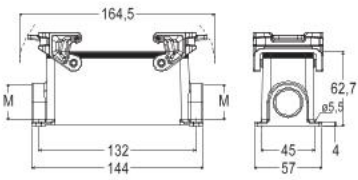

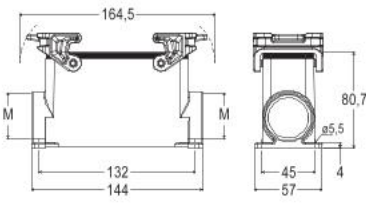

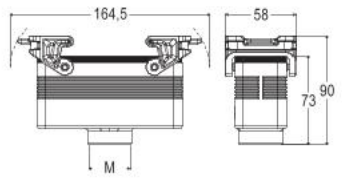

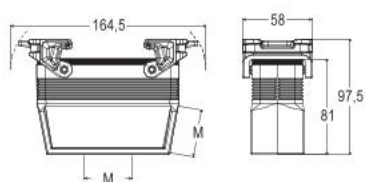
Heavy-Duty Applications 



CE UK CA

EN 60529	IP65
UL 50 / UL 50E	Type 12 / 4 / 4X
Ambient temperature limits	-40 °C ... +125 °C
Mechanical life (cycles)	≥ 500

 (pending CQC)

 ECBT2.E115072 | ECBT8.E115072

Item	Description	Part No.	Entry	Dimension
	Bulkhead mounting housings, 2 levers and gasket	JPI 24		
	Surface mounting housings, 2 levers and gasket	JMPP 24.25 JMPP 24.225	M25 M25 × 2	
	Surface mounting housings, 2 levers and gasket, high construction To be used only with a complete cable gland	JMPAP 24.25 JMPAP 24.225 JMPAP 24.32 JMPAP 24.232 JMPAP 24.40 JMPAP 24.240	M25 M25 × 2 M32 M32 × 2 M40 M40 × 2	
	Hoods, 2 levers and gasket, top entry	Top entry JMPV 24 G32	M32	
	Hoods, 2 levers and gasket, side or top entry, high construction To be used only with a complete cable gland	Side entry Top entry JMPFV 24 G25 JMPFV 24 G32 JMPFO 24 G40 JMPFV 24 G40	M25 M32 M40	

Inserts size 104.27	Poles	Pages	Inserts size 104.27	Poles	Pages	MIXO Modular Inserts	Pages		
CNE	16 A	24 + ⊕	B.41	CSS	16 A	24 + ⊕	3.121	MIXO modules	3.12-93
CCE	16 A	24 + ⊕	B.47	CT / CTSE*	16 A	24 + ⊕	3.129-133	CX 06 T (6-slot sized MIXO frames)	C.93
CSH / JSH S	16 A	24 + ⊕	B.55-57	CT / CTS*	10 A	64 + ⊕	3.139-141		
CSHT	16 A	24 + ⊕	B.68	CMCE / CMSH	16 A	10 + 2 (aux.) + ⊕	3.146-151		
CQE / CQEY	16 A	46 + ⊕	B.75-78	CX	100 A/16 A	8/0 and 6/6 + ⊕	3.156-157		
CQEE	16 A	64 + ⊕	B.79	CX / CXC	80 A/16 A	4/8 + ⊕	3.161-162		
CD	10 A	64 + ⊕	B.91	*can be used only in bulkhead mounting housings					
CDD	10 A	108 + ⊕	B.97					 Hoods Page E.73-77	 Covers Page E.76
CDSH	10 A	42 + ⊕	B.103						

JEI®-P series

Covers – 1 or 2 levers – with gasket

size **44.27 – 104.27**

Heavy-Duty
Applications



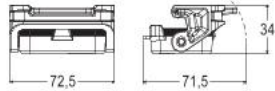


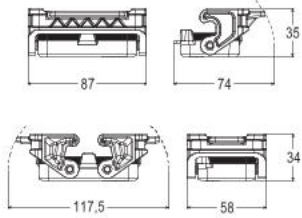


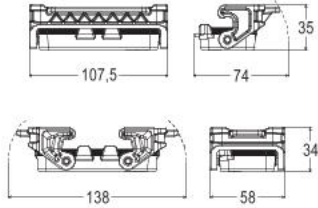


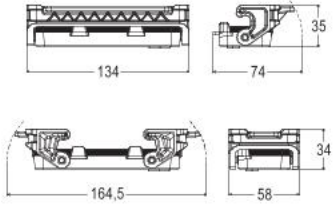


CE UK

EN 60529	IP65
UL 50 / UL 50E	Type 12 / 4 / 4X
Ambient temperature limits	-40 °C ... +125 °C
Mechanical life (cycles)	≥ 500

DNV VERITAS (pending CQC)

CEC US ECBT2.E115072 | ECBT8.E115072

Item	Description	1 lever	2 levers	Dimension
	Covers, 1 lever and gasket, size 44.27 For enclosures with 2 pegs without gasket with loop for hoods 	JPC 06 LG		
	Covers, 1 or 2 levers and gasket, size 57.27 For enclosures with 2 or 4 pegs without gasket with loop for hoods 	JPC 10 LG	JPC 10 G	
	Covers, 1 or 2 levers and gasket, size 77.27 For enclosures with 2 or 4 pegs without gasket with loop for hoods 	JPC 16 LG	JPC 16 G	
	Covers, 1 or 2 levers and gasket, size 104.27 For enclosures with 2 or 4 pegs without gasket with loop for hoods 	JPC 24 LG	JPC 24 G	

Panel cut-out drawings

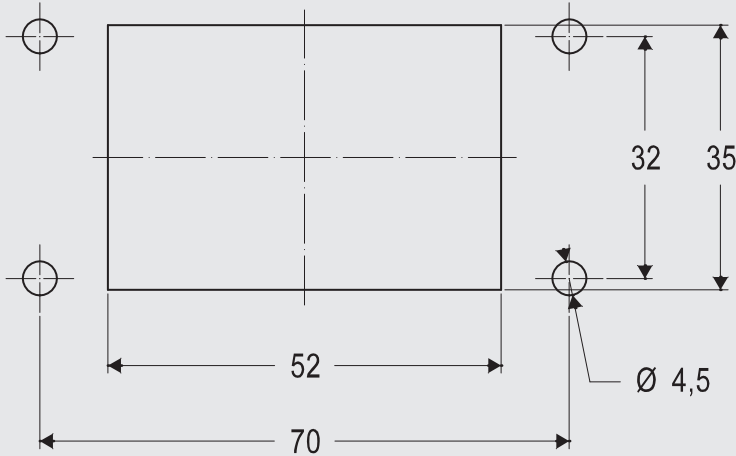
For JEI®-P series bulkhead mounting housings

To guarantee the declared IP degree of protection of the housings reported in this catalogue, according to EN IEC 60529 or to the relevant Type rating per ANSI/UL 50 and 50E (for those products bearing approval to those ratings), the surface of the mounting panel must meet the following requirements (definitions are provided in ISO 4287 standard):

Waviness $Wt \leq 0,2$ mm over a distance of 200 mm (measured on the panel without load)
Roughness $Ra \leq 16$ μ m

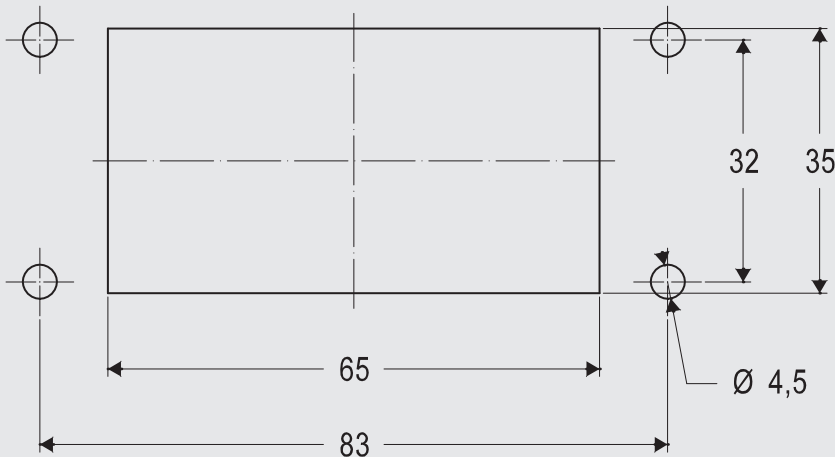
Scale 1:1

Size 44.27



Required screws: 4
Screws size: M4
Recommended torque:
 0,8 – 1,2 Nm / 7.1 – 10.6 lb.in

Size 57.27



Required screws: 4
Screws size: M4
Recommended torque:
 0,8 – 1,2 Nm / 7.1 – 10.6 lb.in

Notes: The values of tightening torque indicated above are just recommended values, that must be related – by the designer of the final application – to the resistance class of the screws (not included), with the assumption that the mounting panel is sufficiently rigid (stiff). If the deflection of the panel, under the effect of tightening the screws, is greater than 0,7 mm over a distance of 100 mm, it is

necessary to use the counter-flanges mentioned in our catalogue or the special flange gaskets available upon request (please contact our Sales Department).

Panel cut-out drawings

For JEI®-P series bulkhead mounting housings

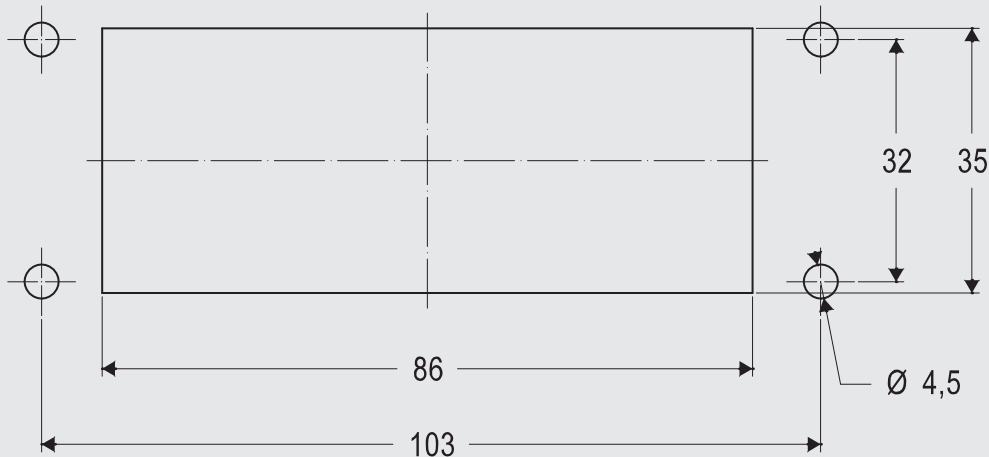
To guarantee the declared IP degree of protection of the housings reported in this catalogue, according to EN IEC 60529 or to the relevant Type rating per ANSI/UL 50 and 50E (for those products bearing approval to those ratings), the surface of the mounting panel must meet the following requirements (definitions are provided in ISO 4287 standard):

Waviness $Wt \leq 0,2$ mm over a distance of 200 mm
(measured on the panel without load)

Roughness $Ra \leq 16$ μ m

Scale 1:1

Size 77.27



Required screws: 4
Screws size: M4
Recommended torque:
0,8 – 1,2 Nm / 7.1 – 10.6 lb.in

Size 104.27



Required screws: 4
Screws size: M4
Recommended torque:
0,8 – 1,2 Nm / 7.1 – 10.6 lb.in

Notes: The values of tightening torque indicated above are just recommended values, that must be related – by the designer of the final application – to the resistance class of the screws (not included), with the assumption that the mounting panel is sufficiently rigid (stiff). If the deflection of the panel, under the effect of tightening the screws, is greater than 0,7 mm over a distance of 100 mm, it is

necessary to use the counter-flanges mentioned in our catalogue or the special flange gaskets available upon request (please contact our Sales Department).



V-TYPE

Extra tough



Standard enclosures with V-TYPE levers

The performance requirements in connection protection are increasingly varied and specialized. To respond to this wide range of needs, ILME has developed several original solutions, including the innovative V-TYPE lever.

This proprietary lever, due to the vertical closing movement, offers an IP66 / **IP67** / IP69 degree of protection (according to EN 60529) when fitted with a complete and coupled connector and used with ILME standard hoods in die-cast aluminium moulded (without adapter).

SUM-UP

- > Made of die cast aluminium alloy
- > Gaskets in anti-aging, oil-resistant, grease-resistant and fuel resistant vinyl nitrile elastomer
- > V-type locking device in stainless-steel
- > Ambient temperature range: -40 °C / +125 °C

❖ Markings and Approvals

- CE and UKA markings, EAC not applicable
- UL certified for USA and Canada for Type 12, 4 and 4X degrees of protection (enclosure type ratings, equivalent to NEMA rating)
- IP66 / IP67 / IP69 degree of protection
- RoHS: compliant



Watch our clip

FOCUS

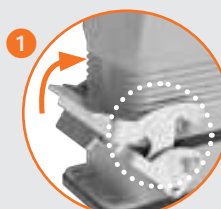
The V-TYPE closing principle consists of a **2-step movement**, thanks to the designed hinged elements pivoted on the housing: **the lever is moved above the housing pegs and then pressed downwards** to engage the locking mechanism.

The tight seal after closure and the simplicity of the movement are the essential attributes that only ILME has managed to combine into a single lever.

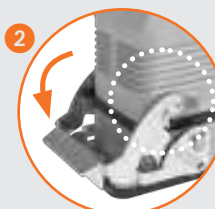
- > High vibration resistance
- > Small overall dimensions
- > Recommended for heavy weight cables or with vertically installed connectors and downwards cable exits

Levers and technology

2-step CLOSING movement ↓




2-step OPENING movement ↑



V-TYPE series – IP67 version

size **44.27**

Housings – 1 lever – with gasket


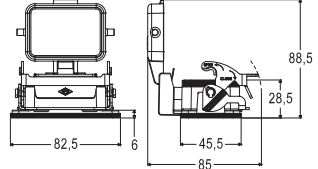

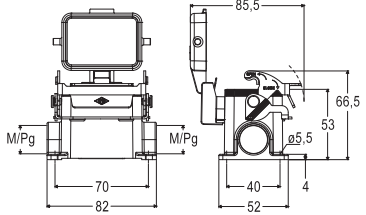

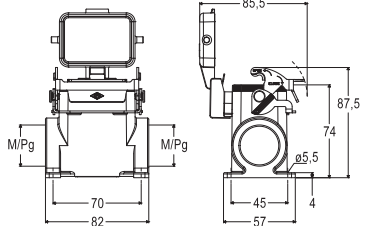
Heavy-Duty Applications 

CE UK CA

EN 60529	IP65 / IP66 / IP67 / IP69
UL 50 / UL 50E	Type 12 / 4 / 4X
Ambient temperature limits	-40 °C ... +125 °C
Mechanical life (cycles)	≥ 500



CAIUS ECBT2.E115072 | ECBT8.E115072

Item	Description	Part No.	With cover	Entry	Dimension
	Bulkhead mounting housings, 1 lever and gasket, with or without metal cover Optional mounting frame C7 .. FL is available to ensure water tightness for bulkhead mounting housing when fitted onto a cabinet panel. (See page G.45)	C7I 06 L	C7I 06 LS		
	Surface mounting housings, 1 lever and gasket, with or without metal cover	M7P 06 L20 M7P 06 L220 C7P 06 L C7P 06 L2	M7P 06 LS20 M7P 06 LS220	M20 M20 x 2 Pg 16 Pg 16 x 2	
	Surface mounting housings, 1 lever and gasket, with or without metal cover, high construction	M7AP 06 L32 M7AP 06 L232 M7AP 06 L40 M7AP 06 L240 C7AP 06 L C7AP 06 L2 C7AP 06 L29 C7AP 06 L229	M7AP 06 LS32 M7AP 06 LS232 M7AP 06 LS40 M7AP 06 LS240	M32 M32 x 2 M40 M40 x 2 Pg 21 Pg 21 x 2 Pg 29 Pg 29 x 2	

V-TYPE – IP67

E

Inserts size 44.27	Poles	Pages	MIXO Modular Inserts	Pages
CNE	16 A 6 + ⊕	B.38	MIXO modules	C.12-93
CCE	16 A 6 + ⊕	B.44	CX 02 T (2-slot sized MIXO frames)	C.95
CSH / JSH S	16 A 6 + ⊕	B.52,58		
CQE / CQEY	16 A 10 + ⊕	B.72,82		
CDD	10 A 24 + ⊕	B.94		
CDSH / CDSH NC	10 A 9 and 6 + ⊕	B.102,108		
CSS	16 A 6 + ⊕	B.118		
CT / CTSE*	16 A 6 + ⊕	B.126,130		

*can be used only in bulkhead mounting housings

Complete with:



Hoods
Page E.49



BIG Hoods
Page E.268



Covers
Page E.52

V-TYPE series – IP67 version

Housings – 2 levers – with gasket

size 57.27

Heavy-Duty Applications

CE UK CA



EN 60529	IP65 / IP66 / IP67 / IP69
UL 50 / UL 50E	Type 12 / 4 / 4X
Ambient temperature limits	-40 °C ... +125 °C
Mechanical life (cycles)	≥ 500

ECBT2.E115072 | ECBT8.E115072

Item	Description	Part No.	Entry	Dimension
	Bulkhead mounting housings, 2 levers and gasket Optional mounting frame C7 .. FL is available to ensure water tightness for bulkhead mounting housing when fitted onto a cabinet panel. (See page G.45)	C7I 10		
	Surface mounting housings, 2 levers and gasket	M7P 10 20 M7P 10 L220 C7P 10 C7P 10.2	M20 M20 x 2 Pg 16 Pg 16 x 2	
	Surface mounting housings, 2 levers and gasket, high construction	M7AP 10.32 M7AP 10.232 M7AP 10.40 M7AP 10.240 C7AP 10.21 C7AP 10.221 C7AP 10.29 C7AP 10.229	M32 M32 x 2 M40 M40 x 2 Pg 21 Pg 21 x 2 Pg 29 Pg 29 x 2	

V-TYPE – IP67

E

Inserts size 57.27	Poles	Pages	Inserts size 57.27	Poles	Pages		
CNE	16 A	10 + ⊕	B.39	CT / CTSE*	16 A	10 + ⊕	B.127,131
CCE	16 A	10 + ⊕	B.45	CMCE / CMSH	16 A	3 + 2 (aux.) + ⊕	B.144,149
CSH / JSH S	16 A	10 + ⊕	B.53,59	CX	40 A/10 A	8/24 + ⊕	B.170-171
CSHT	16 A	10 + ⊕	B.66	*can be used only in bulkhead mounting housings			
CQE / CQEY	16 A	18 + ⊕	B.73,83				
CDD	10 A	42 + ⊕	B.95	MIXO Modular Inserts			
CDSH	10 A	18 + ⊕	B.103	MIXO modules			
CSS	16 A	10 + ⊕	B.119	CX 03 T (3-slot sized MIXO frames)			
			Pages				
			C.12-93				
			C.95				

Complete with:

Hoods
Page E.57,61


BIG Hoods
Page E.269

Covers
Page E.60

V-TYPE series – IP67 version

size **77.27**

Housings – 2 levers – with gasket


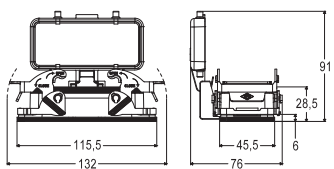

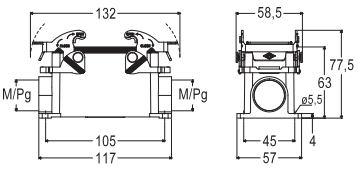

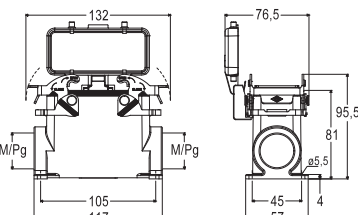
Heavy-Duty Applications 

CE UK CA

EN 60529	IP65 / IP66 / IP67 / IP69
UL 50 / UL 50E	Type 12 / 4 / 4X
Ambient temperature limits	-40 °C ... +125 °C
Mechanical life (cycles)	≥ 500



CAIUS® ECBT2.E115072 | ECBT8.E115072

Item	Description	Part No.	With cover	Entry	Dimension
	Bulkhead mounting housings, 2 levers and gasket, with or without metal cover Optional mounting frame C7 .. FL is available to ensure water tightness for bulkhead mounting housing when fitted onto a cabinet panel. (See page G.45)	C7I 16	C7I 16 S		
	Surface mounting housings, 2 levers and gasket	M7P 16 25 M7P 16 L225 C7P 16 C7P 16.2		M25 M25 x 2 Pg 21 Pg 21 x 2	
	Surface mounting housings, 2 levers and gasket, high construction, with or without metal cover	M7AP 16.32 M7AP 16.232 M7AP 16.40 M7AP 16.240 C7AP 16.21 C7AP 16.221 C7AP 16.29 C7AP 16.229	M7AP 16 S32 M7AP 16 S232	M32 M32 x 2 M40 M40 x 2 Pg 21 Pg 21 x 2 Pg 29 Pg 29 x 2	

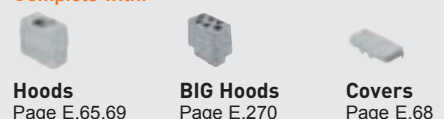
V-TYPE – IP67

E

Inserts size 77.27	Poles	Pages	Inserts size 77.27	Poles	Pages	MIXO Modular Inserts	Pages
CNE	16 + ⊕	B.40	CP / CPY	35 A	6 + ⊕	MIXO modules	C.12-93
CCE	16 A	B.46	CSS	16 A	16 + ⊕	CX 04 T (4-slot sized MIXO frames)	C.95
CSH / JSH S	16 A	B.54,60	CT / CTSE*	16 A	16 + ⊕		
CSHT	16 A	B.67	CT / CTS*	10 A	40 + ⊕		
CQE / CQEY	16 A	B.74,84	CMCE / CMSH	16 A	6 + 2 (aux.) + ⊕		
CQEE	16 A	B.78	CX / CXC	80 A/16 A	4/0, 4/2 + ⊕		
CD	10 A	B.90	CX	40 A/10 A	6/12, 6/36, 9/42 and 12/2 + ⊕		
CDD	10 A	B.94					
CDSH	10 A	B.104					

*can be used only in bulkhead mounting housings

Complete with:



V-TYPE series – IP67 version

Housings – 2 levers – with gasket

size 104.27

Heavy-Duty
Applications


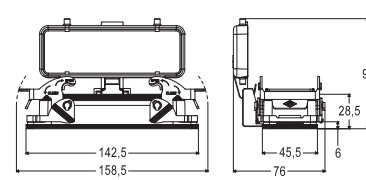

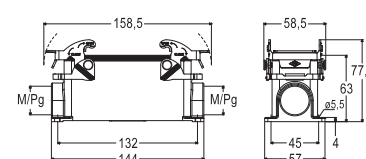

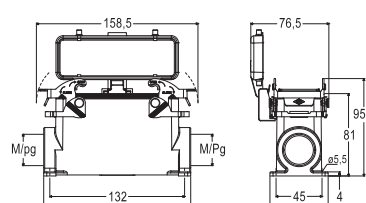


CE UK






EN 60529	IP65 / IP66 / IP67 / IP69
UL 50 / UL 50E	Type 12 / 4 / 4X
Ambient temperature limits	-40 °C ... +125 °C
Mechanical life (cycles)	≥ 500

CEC DNV **ALUS** ECBT2.E115072 | ECBT8.E115072

Item	Description	Part No.	With cover	Entry	Dimension
	Bulkhead mounting housings, 2 levers and gasket, with or without metal cover Optional mounting frame C7 .. FL is available to ensure water tightness for bulkhead mounting housing when fitted onto a cabinet panel. (See page G.45)	C7I 24	C7I 24 S		
	Surface mounting housings, 2 levers and gasket	M7P 24 25 M7P 24 L225 C7P 24 C7P 24.2		M25 M25 x 2 Pg 21 Pg 21 x 2	
	Surface mounting housings, 2 levers and gasket, high construction, with or without metal cover	M7AP 24.32 M7AP 24.232 M7AP 24.40 M7AP 24.240 C7AP 24.21 C7AP 24.221 C7AP 24.29 C7AP 24.229	M7AP 24 S32 M7AP 24 S232	M32 M32 x 2 M40 M40 x 2 Pg 21 Pg 21 x 2 Pg 29 Pg 29 x 2	

V-TYPE – IP67

E

Inserts size 104.27	Poles	Pages	Inserts size 104.27	Poles	Pages	MIXO Modular Inserts	Pages	
CNE	16 A	24 + ☉ B.41	CSS	16 A	24 + ☉ B.121	MIXO modules	C.12-93	
CCE	16 A	24 + ☉ B.47	CT / CTSE*	16 A	24 + ☉ B.129,133	CX 06 T (6-slot sized MIXO frames)	C.95	
CSH / JSH S	16 A	24 + ☉ B.55,61	CT / CTS*	10 A	64 + ☉ B.139,141			
CSHT	16 A	24 + ☉ B.68	CMCE / CMSH	16 A	10 + 2 (aux.) + ☉ B.146,151			
CQE / CQEY	16 A	46 + ☉ B.75,85	CX	100 A/16 A	8/0 and 6/6 + ☉ B.156-157			
CQEE	16 A	64 + ☉ B.79	CX / CXC	80 A/16 A	4/8 + ☉ B.161-162			
CD	10 A	64 + ☉ B.91	*can be used only in bulkhead mounting housings					
CDD	10 A	108 + ☉ B.97				Complete with:		
CDSH	10 A	42 + ☉ B.105					Hoods Page E.73,77	
							BIG Hoods Page E.271	
							Covers Page E.76	


dimensions shown in mm are not binding and may be changed without notice

E.127

V-TYPE series – IP65 / IP66 version

Housings – 1 lever – with gasket

size **44.27**


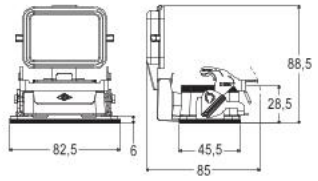

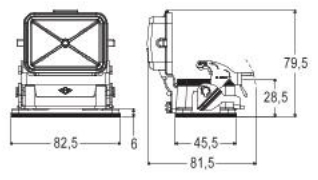

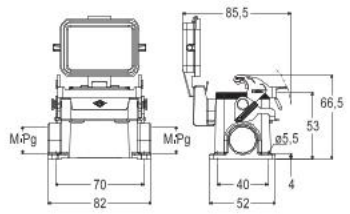

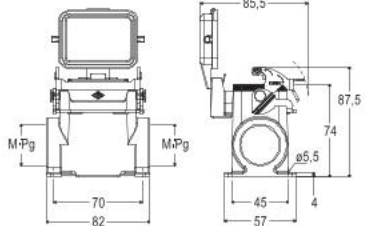

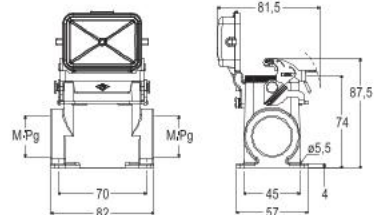
Heavy-Duty Applications 

CE UK

CCC DNV VERITAS

EN 60529	IP65 / IP66 / IP69
UL 50 / UL 50E	Type 12 / 4 / 4X
Ambient temperature limits	-40 °C ... +125 °C
Mechanical life (cycles)	≥ 500

CAIUS ECBT2.E115072 | ECBT8.E115072

Item	Description	Metal cover	Plastic cover	Entry	Dimension
	Bulkhead mounting housings, 1 lever and gasket, with metal or plastic cover Enclosures with plastic cover do not have UL approval	CVI 06 LS	CVI 06 LP		
	Bulkhead mounting housings, 1 lever and gasket, with SIMPLEX self-closing cover Enclosures with plastic cover do not have UL approval		CVI 06 LSP		
	Bulkhead mounting housings, 1 lever and gasket, with metal or plastic cover Enclosures with plastic cover do not have UL approval	MVP 06 LS20 MVP 06 LS220 CVP 06 LS CVP 06 LS2	MVP 06 LP20 MVP 06 LP220 CVP 06 LP CVP 06 LP2	M20 M20 x 2 Pg 16 Pg 16 x 2	
	Bulkhead mounting housings, 1 lever and gasket, with metal or plastic cover, high construction Enclosures with plastic cover do not have UL approval	MVAP 06 LS32 MVAP 06LS232 MVAP 06 LS40 MVAP 06LS240 CVAP 06 LS CVAP 06 LS2 CVAP 06 LS29 CVAP 06LS229	MVAP 06 LP32 MVAP 06LP232 MVAP 06 LP40 MVAP 06LP240 CVAP 06 LP CVAP 06 LP2 CVAP 06 LP29 CVAP 06LP229	M32 M32 x 2 M40 M40 x 2 Pg 21 Pg 21 x 2 Pg 29 Pg 29 x 2	
	Surface mounting housings, 1 lever and gasket, with SIMPLEX self-closing cover, low or high construction Enclosures with plastic cover do not have UL approval	Low construction MVP 06 LSP20 CVP 06 LSP16	High construction MVAP 06LSP25 MVAP 06LSP32 MVAP 06LSP40 CVAP 06LSP21 CVAP 06LSP29	M20 M25 M32 M40 Pg 16 Pg 21 Pg 29	

Inserts size 44.27	Poles	Pages	MIXO Modular Inserts	Pages
CNE	16 A	6 + ⊕	MIXO modules	C.12-93
CCE	16 A	6 + ⊕	CX 02 T (2-slot sized MIXO frames)	C.95
CSH / JSH S	16 A	6 + ⊕		
CQE / CQEY	16 A	10 + ⊕		
CDD	10 A	24 + ⊕		
CDSH / CDSH NC	10 A	9 and 6 + ⊕		
CSS	16 A	6 + ⊕		
CT / CTSE*	16 A	6 + ⊕		

Complete with:



Hoods
Page [E.49](#)



Covers
Page [E.52](#)

*can be used only in bulkhead mounting housings

V-TYPE series – IP65 / IP66 version

size **44.27**


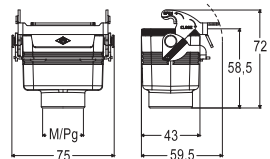

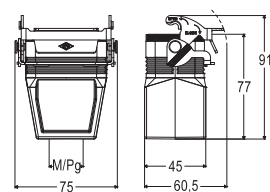
Hoods – 1 lever – with gasket

Heavy-Duty Applications

CE UK


EN 60529	IP65 / IP66 / IP69
UL 50 / UL 50E	Type 12 / 4 / 4X
Ambient temperature limits	-40 °C ... +125 °C
Mechanical life (cycles)	≥ 500

CEC ECBT2.E115072 | ECBT8.E115072

Item	Description	Part No.	Entry	Dimension
	Hoods, 1 lever and gasket, top entry	MVV 06 LG25 CVV 06 LG	M25 Pg 16	
	Hoods, 1 lever and gasket, top entry, high construction To be used only with a complete cable gland	MVFV 06 LG25 MVFV 06 LG32 CVFV 06 LG21 CVFV 06 LG29	M25 M32 Pg 21 Pg 29	

Inserts size 44.27	Poles	Pages	MIXO Modular Inserts	Pages
CNE	16 A 6 + ⊕	B.38	MIXO modules	C.12-93
CCE	16 A 6 + ⊕	B.44	CX 02 T (2-slot sized MIXO frames)	C.95
CSH / JSH S	16 A 6 + ⊕	B.52,58		
CQE / CQEY	16 A 10 + ⊕	B.72,82		
CDD	10 A 24 + ⊕	B.94		
CDSH / CDSH NC	10 A 9 and 6 + ⊕	B.102,108		
CSS	16 A 6 + ⊕	B.118		

Complete with:



Hoods
Page E.49

Covers
Page E.52

V-TYPE series – IP65 / IP66 version

Housings – 1 lever – with gasket

size **57.27**


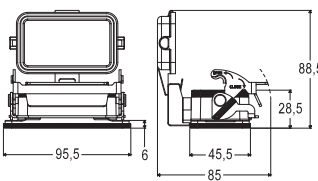

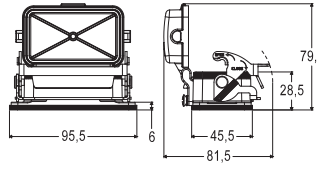

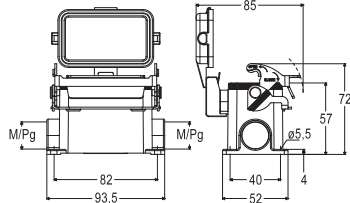

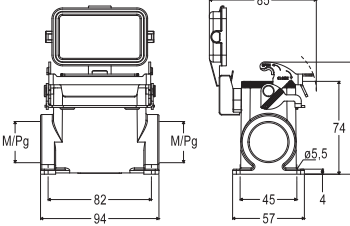

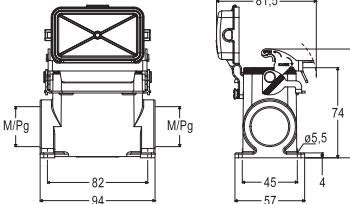
Heavy-Duty Applications 

CE UK CA

EN 60529	IP65 / IP66 / IP69
UL 50 / UL 50E	Type 12 / 4 / 4X
Ambient temperature limits	-40 °C ... +125 °C
Mechanical life (cycles)	≥ 500



CAIUS® ECBT2.E115072 | ECBT8.E115072

Item	Description	Metal cover	Plastic cover	Entry	Dimension
	Bulkhead mounting housings, 1 lever and gasket, with or without metal or plastic cover Enclosures with plastic cover do not have UL approval	CVI 10 LS Without cover CVI 10 L	CVI 10 LP		
	Bulkhead mounting housings, 1 lever and gasket, with SIMPLEX self-closing cover Enclosures with plastic cover do not have UL approval		CVI 10 LSP		
	Bulkhead mounting housings, 1 lever and gasket, with metal or plastic cover Enclosures with plastic cover do not have UL approval	MVP 10 LS20 MVP 10 LS220 CVP 10 LS CVP 10 LS2	MVP 10 LP20 MVP 10 LP220 CVP 10 LP CVP 10 LP2	M20 M20 x 2 Pg 16 Pg 16 x 2	
	Bulkhead mounting housings, 1 lever and gasket, with metal or plastic cover, high construction Enclosures with plastic cover do not have UL approval	MVAP 10 LS32 MVAP 10LS232 MVAP 10 LS40 MVAP 10LS240 CVAP 10 LS CVAP 10 LS2 CVAP 10 LS29 CVAP 10LS229	MVAP 10 LP32 MVAP 10LP232 MVAP 10 LP40 MVAP 10LP240 CVAP 10 LP CVAP 10 LP2 CVAP 10 LP29 CVAP 10LP229	M32 M32 x 2 M40 M40 x 2 Pg 21 Pg 21 x 2 Pg 29 Pg 29 x 2	
	Surface mounting housings, 1 lever and gasket, with SIMPLEX self-closing cover, low or high construction Enclosures with plastic cover do not have UL approval	Low construction MVP 10 LSP20 CVP 10 LSP16	High construction MVAP 10LSP25 MVAP 10LSP32 MVAP 10LSP40 CVAP 10LSP21 CVAP 10LSP29	M20 M25 M32 M40 Pg 16 Pg 21 Pg 29	

Inserts size 57.27	Poles	Pages	Inserts size 57.27	Poles	Pages		
CNE	16 A	10 + ⊕	3.39	CT / CTSE*	16 A	10 + ⊕	3.127-3.131
CCE	16 A	10 + ⊕	3.45	CMCE / CMSH	16 A	3 + 2 (aux.) + ⊕	3.144-3.149
CSH / JSH S	16 A	10 + ⊕	3.53-3.59	CX	40 A/10 A	8/24 + ⊕	3.170-171
CSHT	16 A	10 + ⊕	3.66	*can be used only in bulkhead mounting housings			
CQE / CQEY	16 A	18 + ⊕	3.73-3.83	MIXO Modular Inserts			
CDD	10 A	42 + ⊕	3.95	MIXO modules		C.12-93	
CDSH	10 A	18 + ⊕	3.103	CX 03 T (3-slot sized MIXO frames)		C.95	
CSS	16 A	10 + ⊕	3.119				

Complete with:



Hoods
Page [E.55](#)



Covers
Page [E.60](#)

V-TYPE – IP65 / IP66

E



V-TYPE series – IP65 / IP66 version

size **57.27**

Housings and hoods – 1 or 2 levers – with gasket

Heavy-Duty Applications



EN 60529	IP65 / IP66 / IP69
UL 50 / UL 50E	Type 12 / 4 / 4X
Ambient temperature limits	-40 °C ... +125 °C
Mechanical life (cycles)	≥ 500

ALUS ECBT2.E115072 | ECBT8.E115072

Item	Description	Part No.	Entry	Dimension
	Surface mounting housings, 1 lever and gasket	MVP 10 L20 MVP 10 L220 CVP 10 L CVP 10 L2	M20 M20 x 2 Pg 16 Pg 16 x 2	
	Surface mounting housings, 1 lever and gasket, high construction	MVAP 10 L32 MVAP 10 L232 MVAP 10 L40 MVAP 10 L240 CVAP 10 L CVAP 10 L2 CVAP 10 L29 CVAP 10 L229	M32 M32 x 2 M40 M40 x 2 Pg 21 Pg 21 x 2 Pg 29 Pg 29 x 2	
	Hoods, 1 lever and gasket, top entry, low or high construction High construction hoods to be used only with a complete cable gland	Low construction MVV 10 LG25 CVV 10 LG High construction MVFV 10 LG25 MVFV 10 LG32 CVFV 10 LG21 CVFV 10 LG29	M25 M32 Pg 16 Pg 21 Pg 29	
	Hoods, 2 levers and gasket, top entry, low or high construction High construction hoods to be used only with a complete cable gland	Low construction MVV 10 G25 CVV 10 G High construction MVFV 10 G25 MVFV 10 G32 CVFV 10 G21 CVFV 10 G29	M25 M32 Pg 16 Pg 21 Pg 29	
	Angled bulkhead mounting housings, 1 lever and gasket, with or without cable gland entry Flange gasket for angled bulkhead mounting housings to be purchased separately	With entry MVI 10 LAP32 Flange gasket CR 10 MO Without entry CVI 10 LA	no entry M32	

Inserts size 57.27	Poles	Pages	Inserts size 57.27	Poles	Pages		
CNE	16 A	10 + ⊕	B.39	CMCE / CMSH	16 A	3 + 2 (aux.) + ⊕	B.144 B.149
CCE	16 A	10 + ⊕	B.45	CX	40 A / 10 A	8 / 24 + ⊕	B.170-171
CSH / JSH S	16 A	10 + ⊕	B.53 B.59				
CSHT	16 A	10 + ⊕	B.66				
CQE / CQEY	16 A	18 + ⊕	B.73 B.83				
CDD	10 A	42 + ⊕	B.98				
CDSH	10 A	18 + ⊕	B.103	MIXO Modular Inserts		Pages	
CSS	16 A	10 + ⊕	B.119	MIXO modules		C.12-93	
				CX 03 T (3-slot sized MIXO frames)		C.99	

Complete with:


Hoods
Page [E.55](#) | [E.57](#) | [E.61](#)

Covers
Page [E.60](#)

V-TYPE series – IP65 / IP66 version

Housings – 1 lever – with gasket

size **77.27**


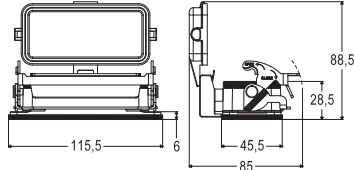

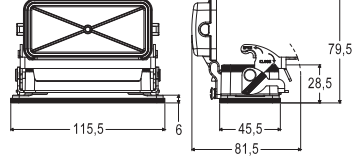

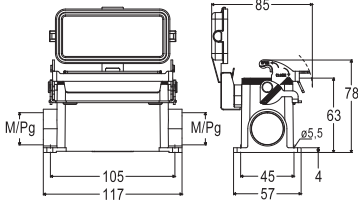

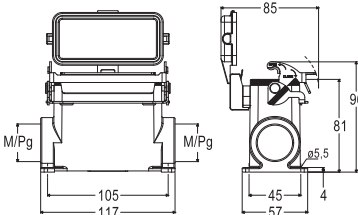

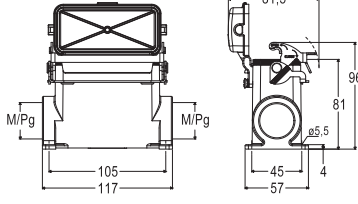
Heavy-Duty Applications 

CE UK

CEC DNV SIFITA

EN 60529	IP65 / IP66 / IP69
UL 50 / UL 50E	Type 12 / 4 / 4X
Ambient temperature limits	-40 °C ... +125 °C
Mechanical life (cycles)	≥ 500

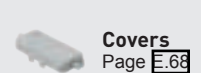
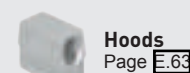
CAUS ECBT2.E115072 | ECBT8.E115072

Item	Description	Metal cover	Plastic cover	Entry	Dimension
	Bulkhead mounting housings, 1 lever and gasket, with or without metal or plastic cover Enclosures with plastic cover do not have UL approval	CVI 16 LS Without cover CVI 16 L	CVI 16 LP		
	Bulkhead mounting housings, 1 lever and gasket, with SIMPLEX self-closing cover Enclosures with plastic cover do not have UL approval		CVI 16 LSP		
	Bulkhead mounting housings, 1 lever and gasket, with metal or plastic cover Enclosures with plastic cover do not have UL approval	MVP 16 LS25 MVP 16 LS225 CVP 16 LS CVP 16 LS2	MVP 16 LP25 MVP 16 LP225 CVP 16 LP CVP 16 LP2	M25 M25 x 2 Pg 21 Pg 21 x 2	
	Bulkhead mounting housings, 1 lever and gasket, with metal or plastic cover, high construction Enclosures with plastic cover do not have UL approval	MVAP 16 LS32 MVAP 16LS232 MVAP 16 LS40 MVAP 16LS240 CVAP 16 LS CVAP 16 LS2 CVAP 16 LS29 CVAP 16LS229	MVAP 16 LP32 MVAP 16LP232 MVAP 16 LP40 MVAP 16LP240 CVAP 16 LP CVAP 16 LP2 CVAP 16 LP29 CVAP 16LP229	M32 M32 x 2 M40 M40 x 2 Pg 21 Pg 21 x 2 Pg 29 Pg 29 x 2	
	Surface mounting housings, 1 lever and gasket, with SIMPLEX self-closing cover, low or high construction Enclosures with plastic cover do not have UL approval	Low construction MVP 16 LSP25 CVP 16 LSP21	High construction MVAP 16LSP25 MVAP 16LSP32 MVAP 16LSP40 CVAP 16LSP21 CVAP 16LSP29	M25 M32 M40 Pg 21 Pg 29	

Inserts size 77.27	Poles	Pages	Inserts size 77.27	Poles	Pages	MIXO Modular Inserts	Pages
CNE 16 A	16 + ⊕	B.40	CP / CPY 35 A	6 + ⊕	B.112 114	MIXO modules	C.12-93
CCE 16 A	16 + ⊕	B.46	CSS 16 A	16 + ⊕	B.120	CX 04 T (4-slot sized MIXO frames)	C.93
CSH / JSH S 16 A	16 + ⊕	B.54 50	CT / CTSE* 16 A	16 + ⊕	B.128 132		
CSHT 16 A	16 + ⊕	B.67	CT / CTS* 10 A	40 + ⊕	B.138 140		
CQE / CQEY 16 A	32 + ⊕	B.74 84	CMCE / CMSH 16 A	6 + 2 (aux.) + ⊕	B.145 150		
CQEE 16 A	40 + ⊕	B.78	CX / CXC 80 A/16 A	4/0, 4/2 + ⊕	B.158-160		
CD 10 A	40 + ⊕	B.90	CX 40 A/10 A	6/12, 6/36, 9/42 and 12/2 + ⊕	B.163-164, 168-169		
CDD 10 A	72 + ⊕	B.94					
CDSH 10 A	27 + ⊕	B.104					

*can be used only in bulkhead mounting housings

Complete with:



V-TYPE series – IP65 / IP66 version

Housings and hoods – 1 or 2 levers – with gasket

size 77.27


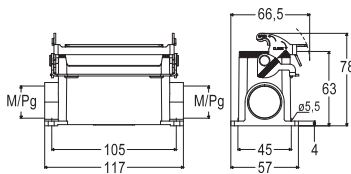

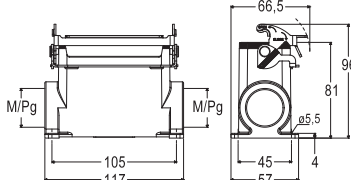

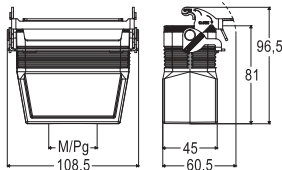

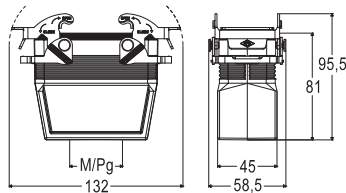
Heavy-Duty Applications 

CE UK



CBUS ECBT2.E115072 | ECBT8.E115072

EN 60529	IP65 / IP66 / IP69
UL 50 / UL 50E	Type 12 / 4 / 4X
Ambient temperature limits	-40 °C ... +125 °C
Mechanical life (cycles)	≥ 500

Item	Description	Part No.	Entry	Dimension
	Surface mounting housings, 1 lever and gasket	MVP 16 L25 MVP 16 L225 CVP 16 L CVP 16 L2	M25 M25 x 2 Pg 21 Pg 21 x 2	
	Surface mounting housings, 1 lever and gasket, high construction	MVAP 16 L32 MVAP 16 L232 MVAP 16 L40 MVAP 16 L240 CVAP 16 L CVAP 16 L2 CVAP 16 L29 CVAP 16 L229	M32 M32 x 2 M40 M40 x 2 Pg 21 Pg 21 x 2 Pg 29 Pg 29 x 2	
	Hoods, 1 lever and gasket, top entry, low or high construction High construction hoods to be used only with a complete cable gland	Low construction MVV 16 LG32 CVV 16 LG	High construction MVFV 16 LG25 MVFV 16 LG32 CVFV 16 LG21 CVFV 16 LG29	M25 M32 Pg 21 Pg 29 
	Hoods, 2 levers and gasket, top entry, low or high construction High construction hoods to be used only with a complete cable gland	Low construction MVV 16 G32 CVV 16 G	High construction MVFV 16 G25 MVFV 16 G32 CVFV 16 G21 CVFV 16 G29	M25 M32 Pg 21 Pg 29 

V-TYPE – IP65 / IP66

E

Inserts size 77.27	Poles	Pages	Inserts size 77.27	Poles	Pages	MIXO Modular Inserts	Pages
CNE	16 A	16 + ⊕ B.40	CP / CPY	35 A	6 + ⊕	MIXO modules	C.12-93
CCE	16 A	16 + ⊕ B.46	CSS	16 A	16 + ⊕	CX 04 T (4-slot sized MIXO frames)	C.95
CSH / JSH S	16 A	16 + ⊕ B.54,60	CMCE / CMSH	16 A	6 + 2 (aux.) + ⊕		
CSHT	16 A	16 + ⊕ B.67	CX / CXC	80 A/16 A	4/0, 4/2 + ⊕		
CQE / CQEY	16 A	32 + ⊕ B.74,84					
CQEE	16 A	40 + ⊕ B.78	CX	40 A/10 A	6/12, 6/36, 9/42 and 12/2 + ⊕		
CD	10 A	40 + ⊕ B.90					
CDD	10 A	72 + ⊕ B.94					
CDSH	10 A	27 + ⊕ B.104					

Complete with:



Hoods
Page E.63,65,69




Covers
Page E.68

V-TYPE series – IP65 / IP66 version

Housings – 1 lever – with gasket

size **104.27**


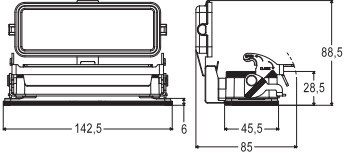

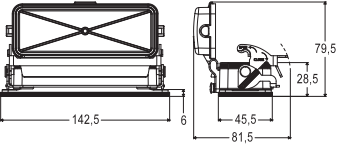

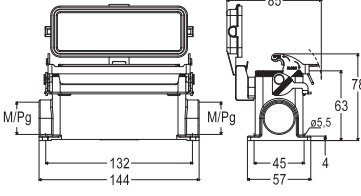

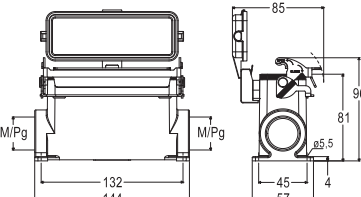

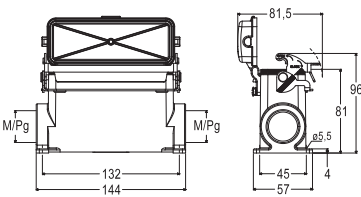
Heavy-Duty Applications 

CE UK CA

CEC DNV SPINA

EN 60529	IP65 / IP66 / IP69
UL 50 / UL 50E	Type 12 / 4 / 4X
Ambient temperature limits	-40 °C ... +125 °C
Mechanical life (cycles)	≥ 500

CAIUS ECBT2.E115072 | ECBT8.E115072

Item	Description	Metal cover	Plastic cover	Entry	Dimension
	Bulkhead mounting housings, 1 lever and gasket, with or without metal or plastic cover	CVI 24 LS	CVI 24 LP		
	Enclosures with plastic cover do not have UL approval	Without cover CVI 24 L			
	Bulkhead mounting housings, 1 lever and gasket, with SIMPLEX self-closing cover		CVI 24 LSP		
	Enclosures with plastic cover do not have UL approval				
	Bulkhead mounting housings, 1 lever and gasket, with metal or plastic cover	MVP 16 LS25 MVP 16 LS225 CVP 16 LS CVP 16 LS2	MVP 16 LP25 MVP 16 LP225 CVP 16 LP CVP 16 LP2	M25 M25 x 2 Pg 21 Pg 21 x 2	
	Enclosures with plastic cover do not have UL approval				
	Bulkhead mounting housings, 1 lever and gasket, with metal or plastic cover, high construction	MVAP 24 LS32 MVAP 24LS232 MVAP 24 LS40 MVAP 24LS240 CVAP 24 LS CVAP 24 LS2 CVAP 24 LS29 CVAP 24LS229	MVAP 24 LP32 MVAP 24LP232 MVAP 24 LP40 MVAP 24LP240 CVAP 24 LP CVAP 24 LP2 CVAP 24 LP29 CVAP 24LP229	M32 M32 x 2 M40 M40 x 2 Pg 21 Pg 21 x 2 Pg 29 Pg 29 x 2	
	Enclosures with plastic cover do not have UL approval				
	Surface mounting housings, 1 lever and gasket, with SIMPLEX self-closing cover, low or high construction	Low construction MVP 24 LSP25	High construction MVAP 24LSP25 MVAP 24LSP32 MVAP 24LSP40 CVAP 24LSP21 CVAP 24LSP29	M25 M32 M40 Pg 21 Pg 29	
	Enclosures with plastic cover do not have UL approval	CVP 24 LSP21			

Inserts size 104.27	Poles	Pages	Inserts size 104.27	Poles	Pages	MIXO Modular Inserts	Pages
CNE 16 A	24 + ⊕	B.41	CSS 16 A	24 + ⊕	B.121	MIXO modules	C.12-93
CCE 16 A	24 + ⊕	B.47	CT / CTSE* 16 A	24 + ⊕	B.129 B.133	CX 06 T (6-slot sized MIXO frames)	C.93
CSH / JSH S 16 A	24 + ⊕	B.55 B.71	CT / CTS* 10 A	64 + ⊕	B.139 B.141		
CSHT 16 A	24 + ⊕	B.68	CMCE / CMSH 16 A	10 + 2 (aux.) + ⊕	B.146 B.151		
CQE / CQEY 16 A	46 + ⊕	B.75 B.83	CX 100 A/16 A	8/0 and 6/6 + ⊕	B.156-157		
CQEE 16 A	64 + ⊕	B.79	CX / CXC 80 A/16 A	4/8 + ⊕	B.161-162		
CD 10 A	64 + ⊕	B.91	*can be used only in bulkhead mounting housings				
CDD 10 A	108 + ⊕	B.97					
CDSH 10 A	42 + ⊕	B.103					

Complete with:



Hoods
Page [E.71](#)




Covers
Page [E.76](#)

V-TYPE series – IP65 / IP66 version

Housings and hoods – 1 or 2 levers – with gasket

size 104.27


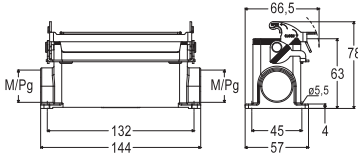

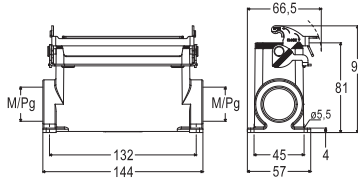

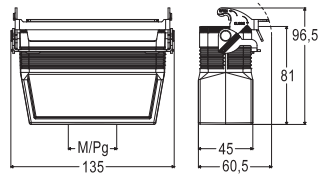

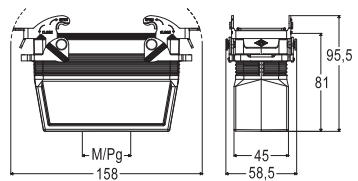
Heavy-Duty
Applications 

CE UK
CA



EN 60529	IP65 / IP66 / IP69
UL 50 / UL 50E	Type 12 / 4 / 4X
Ambient temperature limits	-40 °C ... +125 °C
Mechanical life (cycles)	≥ 500

 ECBT2.E115072 | ECBT8.E115072

Item	Description	Part No.	Entry	Dimension
	Surface mounting housings, 1 lever and gasket	MVP 24 L25 MVP 24 L225 CVP 24 L CVP 24 L2	M25 M25 x 2 Pg 21 Pg 21 x 2	
	Surface mounting housings, 1 lever and gasket, high construction	MVAP 24 L32 MVAP 24 L232 MVAP 24 L40 MVAP 24 L240 CVAP 24 L CVAP 24 L2 CVAP 24 L29 CVAP 24 L229	M32 M32 x 2 M40 M40 x 2 Pg 21 Pg 21 x 2 Pg 29 Pg 29 x 2	
	Hoods, 1 lever and gasket, top entry, low or high construction High construction hoods to be used only with a complete cable gland	Low construction MVV 24 LG32 CVV 24 LG	High construction MVFV 24 LG25 MVFV 24 LG32 CVFV 24 LG21 CVFV 24 LG29	M25 M32 Pg 21 Pg 29 
	Hoods, 2 levers and gasket, top entry, low or high construction High construction hoods to be used only with a complete cable gland	Low construction MVV 24 G32 CVV 24 G	High construction MVFV 24 G25 MVFV 24 G32 CVFV 24 G21 CVFV 24 G29	M25 M32 Pg 21 Pg 29 

V-TYPE – IP65 / IP66

E

Inserts size 104.27	Poles	Pages	Inserts size 104.27	Poles	Pages	MIXO Modular Inserts	Pages
CNE	16 A	24 + ⊕ B.41	CSS	16 A	24 + ⊕ B.121	MIXO modules	C.12-93
CCE	16 A	24 + ⊕ B.47	CMCE / CMSH	16 A	10 + 2 (aux.) + ⊕ B.146,151	CX 06 T (6-slot sized MIXO frames)	C.95
CSH / JSH S	16 A	24 + ⊕ B.55,61	CX	100 A/16 A	8/0 and 6/6 + ⊕ B.156-157		
CSHT	16 A	24 + ⊕ B.68	CX / CXC	80 A/16 A	4/8 + ⊕ B.161-162		
CQE / CQEY	16 A	46 + ⊕ B.75,85					
CQEE	16 A	64 + ⊕ B.79					
CD	10 A	64 + ⊕ B.91					
CDD	10 A	108 + ⊕ B.97					
CDSH	10 A	42 + ⊕ B.105					

Complete with:



Hoods
Page
E.71,73,77



Covers
Page E.76

Panel cut-out drawings

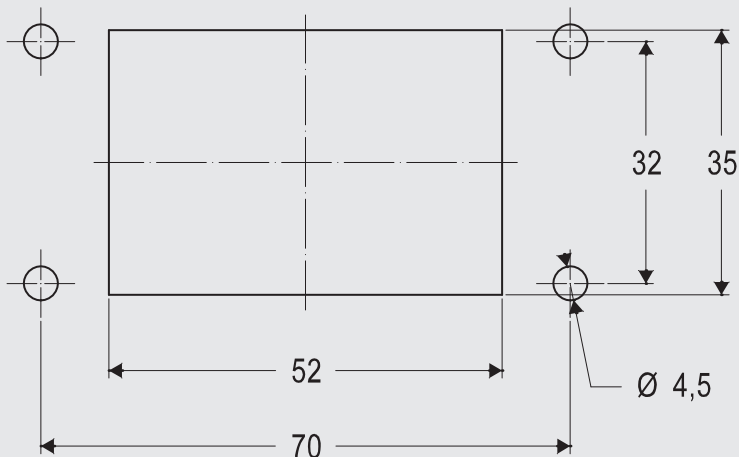
For V-TYPE series bulkhead mounting housings

To guarantee the declared IP degree of protection of the housings reported in this catalogue, according to EN IEC 60529 or to the relevant Type rating per ANSI/UL 50 and 50E (for those products bearing approval to those ratings), the surface of the mounting panel must meet the following requirements (definitions are provided in ISO 4287 standard):

Waviness $W_t \leq 0,2$ mm over a distance of 200 mm (measured on the panel without load)
Roughness $R_a \leq 16$ μ m

Scale 1:1

Size 44.27



Required screws: 4
Screws size: M4
Recommended torque:
 0,8 – 1,2 Nm / 7.1 – 10.6 lb.in

Size 57.27



Required screws: 4
Screws size: M4
Recommended torque:
 0,8 – 1,2 Nm / 7.1 – 10.6 lb.in

Notes: The values of tightening torque indicated above are just recommended values, that must be related – by the designer of the final application – to the resistance class of the screws (not included), with the assumption that the mounting panel is sufficiently rigid (stiff). If the deflection of the panel, under the effect of tightening the screws, is greater than 0,7 mm over a distance of 100 mm, it is necessary to use the counter-flanges mentioned in our catalogue or the special flange gaskets available upon request (please contact our Sales Department).

Accessories:



C7 .. FL
Counterflanges for V-TYPE IP67
bulkhead mounting housings
 Page G.45

Panel cut-out drawings

For V-TYPE series bulkhead mounting housings

To guarantee the declared IP degree of protection of the housings reported in this catalogue, according to EN IEC 60529 or to the relevant Type rating per ANSI/UL 50 and 50E (for those products bearing approval to those ratings), the surface of the mounting panel must meet the following requirements (definitions are provided in ISO 4287 standard):

Waviness $W_t \leq 0,2$ mm over a distance of 200 mm
(measured on the panel without load)

Roughness $R_a \leq 16$ μ m

Scale 1:1

Size 77.27



Required screws: 4
Screws size: M4
Recommended torque:
0,8 – 1,2 Nm / 7.1 – 10.6 lb.in

Size 104.27



Required screws: 4
Screws size: M4
Recommended torque:
0,8 – 1,2 Nm / 7.1 – 10.6 lb.in

Notes: The values of tightening torque indicated above are just recommended values, that must be related – by the designer of the final application – to the resistance class of the screws (not included), with the assumption that the mounting panel is sufficiently rigid (stiff). If the deflection of the panel, under the effect of tightening the screws, is greater than 0,7 mm over a distance of 100 mm, it is necessary to use the counter-flanges mentioned in our catalogue or the special flange gaskets available upon request (please contact our Sales Department).

Accessories:



C7 .. FL
Counterflanges for V-TYPE IP67
bulkhead mounting housings
Page G.45



IP68

High protection series



IP68 CG/MG series

The CG/MG enclosure series for heavy-duty rectangular connectors combines IP68 water tightness, high mechanical sturdiness, and enhanced immunity to electromagnetic disturbances (EMC shielding).

Compared to the standard size series, the larger dimensions of the IP68 enclosure leave more space for the cables while keeping the same panel cutouts.

IP68 means the total protection against dust, and against access to hazardous parts with an access probe of $\varnothing 1,0$ mm (1st Index - IP6x), and protection against the effects of continuous submersion in water (duration ≥ 30 min upon agreement and water depth ≥ 1 m upon agreement) (2nd Index - IPx8).

These enclosures have also successfully passed the tests required for the IPX6 degree of protection (tightness to powerful water jets) and for the IPX9 degree of protection (high pressure and temperature water jets) according to EN IEC 60529. Therefore, their whole "versatile" degree of protection is IP66 / IP68 / IP69.

The table aside shows only the IP68 level of protection.

Please see page J.6 for the complete table of the different levels of protection specified by the IP standard.

❖ Markings and Approvals


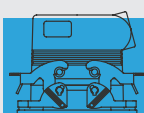
- CE and UKCA markings, EAC not applicable
- UL certified for USA and Canada for Type 12, 4 and 4X degrees of protection (enclosure type ratings, equivalent to NEMA rating)
- IP66 / IP68 / IP69 degree of protection
- RoHS: compliant



Watch our clip

FOCUS

Levers and technology

FIRST Index figure	Degree of protection SOLIDS		SECOND Index figure	Degree of protection WATER	
6		Protected against access to hazardous parts with a wire dust-tight (total protection against dust)	8		Protected against the effects of continuous immersion in water at depth and/or duration upon agreement, more severe than for numeral 7

Description according to IEC 60529

IP68 Enclosures E-Xtreme® series



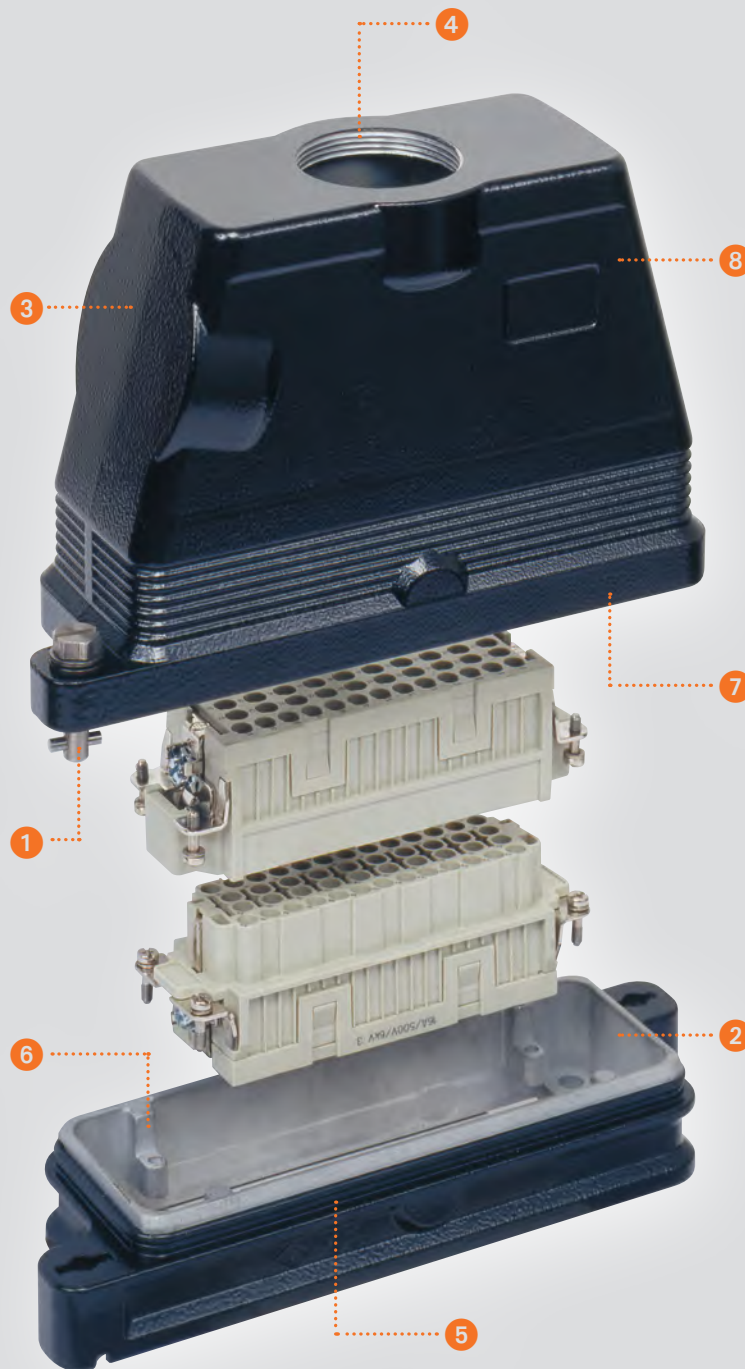
IP68 Enclosures range is also available with E-Xtreme® corrosion-proof treatment to ensure resistance even to very harsh environments (up to 3.000 hours in salt spray test EN ISO 9227:2012).

See pages E.168-169, E.190-193

IP68

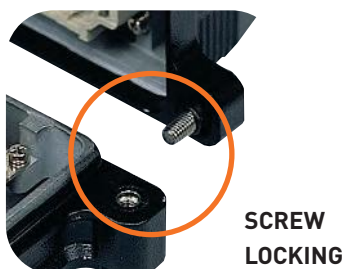
High protection series

TECHNICAL FEATURES



- 1 Locking is available in two solutions: **screw-type** with hexagonal head stainless steel screws or **bayonet-type**.

The slotted hexagonal head screws can be fitted and removed by using either a 1,6 mm thick blade screwdriver or a 10 mm hexagonal key and can be easily accessed even when fitted on enclosures with horizontally exited cables. Tightening torque 2,5 Nm. captive insert fastening screws, with anti-loosening spring washer:



- 2 Corrosion proof foundry grade aluminium alloy enclosures. The following types are available: wall-mounted, flush mounted fixed and free enclosures with free protective cover.
- 3 Epoxy-polyester thermosetting powder coating, colour black RAL 9005, resistant to external agents and impacts.
- 4 Threaded cable entry hole, available in different Pg diameters (types with prefix starting with "C") or metric thread (types with prefix starting with "M") compliant with EN 60423 standard, for cable entry devices compliant with EN IEC 62444 standard (former EN 50262), for vertical or horizontal layout.
- 5 Oil and fuel-resistant NBR seals mounted internally to avoid exposure to sunlight and other ageing factors. When fitted with suitable cable entry devices (not supplied), the enclosures ensure mated connectors' IP66 / IP68 / IP69 degree of protection.
- 6 Fixed, bulkhead-mount enclosure with fastening screws inside the gasket.
- 7 Wider enclosures to give more space for the cabling.
- 8 Hood shielding for electromagnetic compatibility, resistance to vibrations in compliance with EN 61373 railway standard and to pressurised water (IPX9).

IP68 high protection series

Housings, hoods and covers – Screw locking

size **44.27**

Aggressive Environments


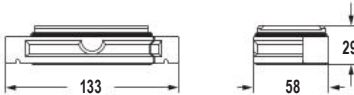

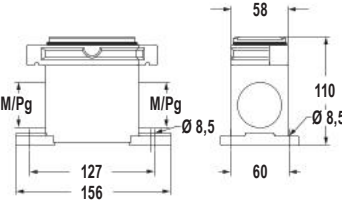

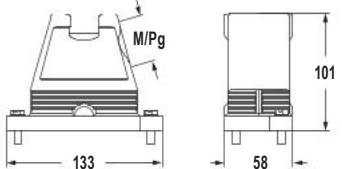

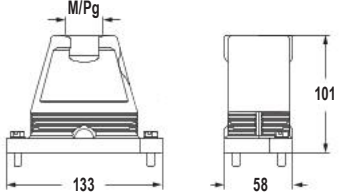


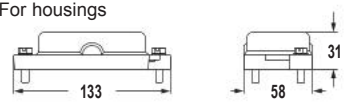
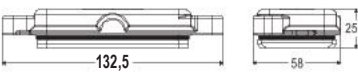


CE UK



EN 60529	IP66 / IP68 / IP69
UL 50 / UL 50E	Type 12 / 4 / 4X
Ambient temperature limits	-40 °C ... +125 °C
Mechanical life (cycles)	≥ 500

CAIUS ECBT2.E115072 | ECBT8.E115072

Item	Description	Part No.	Entry	Dimension
	<p>Bulkhead mounting housings, screw locking</p> <p>Optional mounting frame CG .. FL is available to ensure water tightness for bulkhead mounting housing when fitted onto a cabinet panel. (See page 6.44)</p>	CGI 06		
	<p>Surface mounting housings, screw locking</p>	MGP 06.32 CGP 06.29	M32 Pg 29	
	<p>Hoods, side entry, screw locking</p> <p>To be used only with a complete cable gland</p>	MGO 06.25 MGO 06.32 CGO 06.16 CGO 06.21 CGO 06.29	M25 M32 Pg 16 Pg 21 Pg 29	
	<p>Hoods, top entry, screw locking</p> <p>To be used only with a complete cable gland</p>	MGV 06.25 MGV 06.32 MGV 06.40 CGV 06.16 CGV 06.21 CGV 06.29	M25 M32 M40 Pg 16 Pg 21 Pg 29	
	<p>Covers, screw locking, for housings or for hoods</p> <p>With loop </p>	<p>For housings CGC 06</p> <p>For hoods CGC 06 G</p>		<p>For housings</p>  <p>For hoods</p> 

Inserts size 44.27	Poles	Pages	MIXO Modular Inserts	Pages
CNE	16 A	6 + ⊕	MIXO modules	C.12-93
CCE	16 A	6 + ⊕	CX 02 T (2-slot sized MIXO frames)	C.95
CSH / JSH S	16 A	6 + ⊕		
CQE / CQEY	16 A	10 + ⊕		
CDD	10 A	24 + ⊕		
CDSH / CDSH NC	10 A	9 and 6 + ⊕		
CSS	16 A	6 + ⊕		
CT / CTSE*	16 A	6 + ⊕		

Accessories:

 **CGCP FX**
Dust protection cover
Page [6.47](#)

 **CGCP MB**
Dust protection cover
Page [6.47](#)

*can be used only in bulkhead mounting housings

IP68 high protection series

Housings, hoods and covers – Bayonet locking


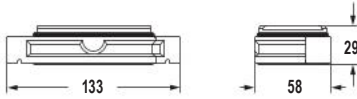

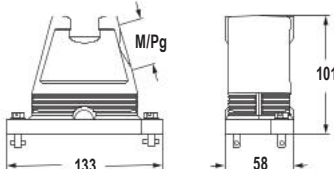

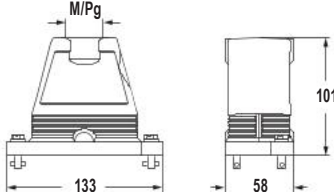



size **44.27**
Aggressive Environments


CE UK



EN 60529	IP66 / IP68 / IP69
UL 50 / UL 50E	Type 12 / 4 / 4X
Ambient temperature limits	-40 °C ... +125 °C
Mechanical life (cycles)	≥ 500

 ECBT2.E115072 | ECBT8.E115072

Item	Description	Part No.	Entry	Dimension
	Bulkhead mounting housings, bayonet locking Optional mounting frame CG .. FL is available to ensure water tightness for bulkhead mounting housing when fitted onto a cabinet panel. (See page E.43)	CGI 06 B		
	Hoods, side entry, bayonet locking To be used only with a complete cable gland	MGO 06.25 B MGO 06.32 B CGO 06.16 B CGO 06.21 B CGO 06.29 B	M25 M32 Pg 16 Pg 21 Pg 29	
	Hoods, top entry, bayonet locking To be used only with a complete cable gland	MGV 06.25 B MGV 06.32 B MGV 06.40 B CGV 06.16 B CGV 06.21 B CGV 06.29 B	M25 M32 M40 Pg 16 Pg 21 Pg 29	
	Covers, bayonet locking, for housings With loop 	CGC 06 B		

Inserts size 44.27	Poles	Pages	MIXO Modular Inserts	Pages
CNE	16 A 6 + ⊕	E.38	MIXO modules	E.12-93
CCE	16 A 6 + ⊕	E.44	CX 02 T (2-slot sized MIXO frames)	E.93
CSH / JSH S	16 A 6 + ⊕	E.52 E.58		
CQE / CQEY	16 A 10 + ⊕	E.72 E.82		
CDD	10 A 24 + ⊕	E.94		
CDSH / CDSH NC	10 A 9 and 6 + ⊕	E.102 E.108		
CSS	16 A 6 + ⊕	E.118		
CT / CTSE*	16 A 6 + ⊕	E.126 E.130		

*can be used only in bulkhead mounting housings

Accessories:

CGCP FX
 Dust protection cover
 Page [E.47](#)

CGCP MB
 Dust protection cover
 Page [E.47](#)

IP68 high protection series

Housings, hoods and covers – Screw locking

size **57.27**


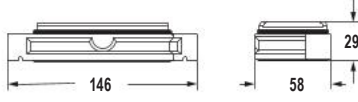

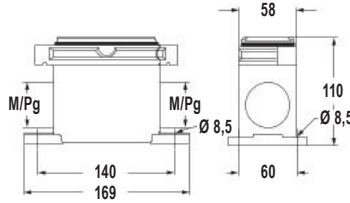

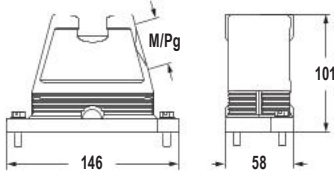

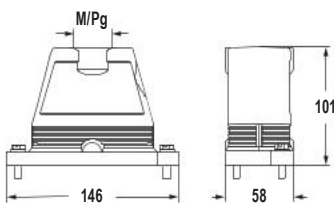
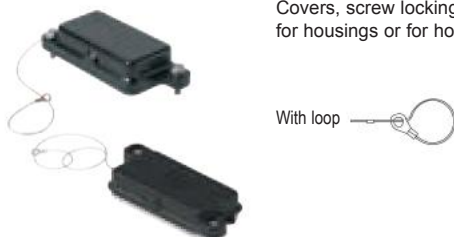

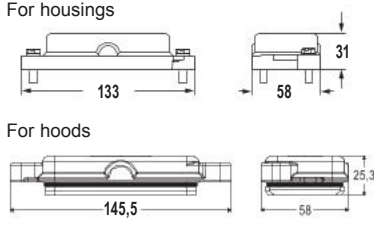
Aggressive Environments 

CE UK

CEC DNV VERITAS

EN 60529	IP66 / IP68 / IP69
UL 50 / UL 50E	Type 12 / 4 / 4X
Ambient temperature limits	-40 °C ... +125 °C
Mechanical life (cycles)	≥ 500

CAIUS ECBT2.E115072 | ECBT8.E115072

Item	Description	Part No.	Entry	Dimension
	Bulkhead mounting housings, screw locking Optional mounting frame CG .. FL is available to ensure water tightness for bulkhead mounting housing when fitted onto a cabinet panel. (See page 6.43)	CGI 10		
	Surface mounting housings, screw locking	MGP 10.32 CGP 10.29	M32 Pg 29	
	Hoods, side entry, screw locking To be used only with a complete cable gland	MGO 10.25 MGO 10.32 CGO 10.16 CGO 10.21 CGO 10.29	M25 M32 Pg 16 Pg 21 Pg 29	
	Hoods, top entry, screw locking To be used only with a complete cable gland	MGV 10.25 MGV 10.32 MGV 10.40 CGV 10.16 CGV 10.21 CGV 10.29	M25 M32 M40 Pg 16 Pg 21 Pg 29	
	Covers, screw locking, for housings or for hoods With loop 	For housings CGC 10 For hoods CGC 10 G		

Inserts size 57.27	Poles	Pages	Inserts size 57.27	Poles	Pages
CNE	16 A	10 + ⊕	CT / CTSE*	16 A	10 + ⊕
CCE	16 A	10 + ⊕	CMCE / CMSH	16 A	3 + 2 (aux.) + ⊕
CSH / JSH S	16 A	10 + ⊕	CX	40 A/10 A	8/24 + ⊕
CSHT	16 A	10 + ⊕	*can be used only in bulkhead mounting housings		
CQE / CQEY	16 A	18 + ⊕	MIXO Modular Inserts		
CDD	10 A	42 + ⊕	MIXO modules		
CDSH	10 A	18 + ⊕	CX 03 T (3-slot sized MIXO frames)		
CSS	16 A	10 + ⊕			

Accessories:

 **CGCP FX**
Dust protection cover
Page [6.47](#)

 **CGCP MB**
Dust protection cover
Page [6.47](#)

IP68 high protection series


Housings, hoods and covers – Bayonet locking


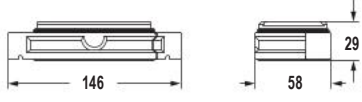

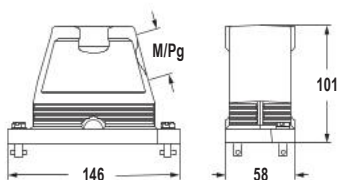

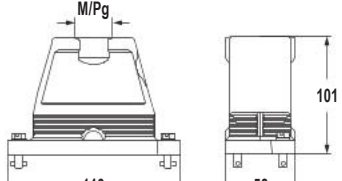


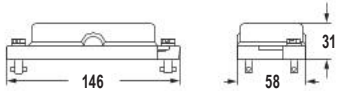
size **57.27**
Aggressive Environments


CE UK



EN 60529	IP66 / IP68 / IP69
UL 50 / UL 50E	Type 12 / 4 / 4X
Ambient temperature limits	-40 °C ... +125 °C
Mechanical life (cycles)	≥ 500

 ECBT2.E115072 | ECBT8.E115072

Item	Description	Part No.	Entry	Dimension
	Bulkhead mounting housings, bayonet locking Optional mounting frame CG .. FL is available to ensure water tightness for bulkhead mounting housing when fitted onto a cabinet panel. (See page E.43)	CGI 10 B		
	Hoods, side entry, bayonet locking To be used only with a complete cable gland	MGO 10.25 B MGO 10.32 B CGO 10.16 B CGO 10.21 B CGO 10.29 B	M25 M32 Pg 16 Pg 21 Pg 29	
	Hoods, top entry, bayonet locking To be used only with a complete cable gland	MGV 10.25 B MGV 10.32 B MGV 10.40 B CGV 10.16 B CGV 10.21 B CGV 10.29 B	M25 M32 M40 Pg 16 Pg 21 Pg 29	
	Covers, bayonet locking, for housings With loop 	CGC 10 B		

Inserts size 57.27	Poles	Pages	Inserts size 57.27	Poles	Pages
CNE	16 A	10 + ⊕ E.39	CT / CTSE*	16 A	10 + ⊕ E.127 E.131
CCE	16 A	10 + ⊕ E.45	CMCE / CMSH	16 A	3 + 2 (aux.) + ⊕ E.144 E.149
CSH / JSH S	16 A	10 + ⊕ E.53 E.59	CX	40 A/10 A	8/24 + ⊕ E.170 E.171
CSHT	16 A	10 + ⊕ E.66	*can be used only in bulkhead mounting housings		
CQE / CQEY	16 A	18 + ⊕ E.73 E.83	MIXO Modular Inserts		
CDD	10 A	42 + ⊕ E.98	MIXO modules		
CDSH	10 A	18 + ⊕ E.103	MIXO 03 T (3-slot sized MIXO frames)		
CSS	16 A	10 + ⊕ E.119	E.12-93 E.93		

Accessories:

CGCP FX
 Dust protection cover
 Page [E.47](#)

CGCP MB
 Dust protection cover
 Page [E.47](#)

IP68 high protection series

Housings, hoods and covers – Screw locking

size **77.27**


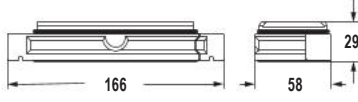

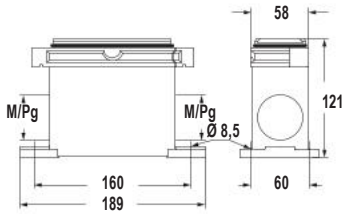

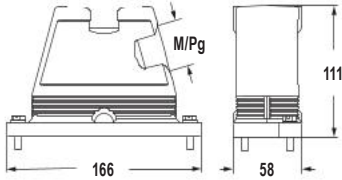

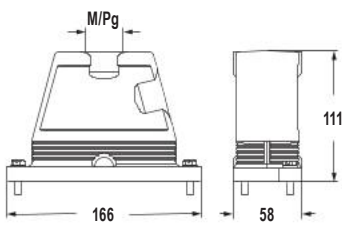


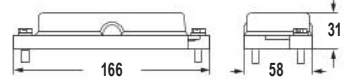
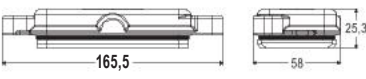
Aggressive Environments 

CE UK CA

CCC DNV VERITAS

EN 60529	IP66 / IP68 / IP69
UL 50 / UL 50E	Type 12 / 4 / 4X
Ambient temperature limits	-40 °C ... +125 °C
Mechanical life (cycles)	≥ 500

ALUS ECBT2.E115072 | ECBT8.E115072

Item	Description	Part No.	Entry	Dimension
	<p>Bulkhead mounting housings, screw locking</p> <p>Optional mounting frame CG .. FL is available to ensure water tightness for bulkhead mounting housing when fitted onto a cabinet panel. (See page G.43)</p>	CGI 16		
	Surface mounting housings, screw locking	MGP 16.40 CGP 16.36	M40 Pg 36	
	<p>Hoods, side entry, screw locking</p> <p>To be used only with a complete cable gland</p>	MGO 16.32 MGO 16.40 MGO 16.50 CGO 16.21 CGO 16.29 CGO 16.36	M32 M40 M50 Pg 21 Pg 29 Pg 36	
	<p>Hoods, top entry, screw locking</p> <p>To be used only with a complete cable gland</p>	MGV 16.25 MGV 16.225 MGV 16.32 MGO 16.40 MGV 16.50 CGV 16.21 CGV 16.221 CGV 16.29 CGV 16.36	M25 M25 x 2 M32 M40 M50 Pg 21 Pg 21 x 2 Pg 29 Pg 36	
	<p>Covers, screw locking, for housings or for hoods</p> <p>With loop </p>	CGC 16	For housings CGC 16 G	<p>For housings: </p> <p>For hoods: </p>

Inserts size 77.27	Poles	Pages	Inserts size 77.27	Poles	Pages	MIXO Modular Inserts	Pages
CNE 16 A	16 + ⊕	B.40	CP / CPY 35 A	6 + ⊕	B.112 B.114	MIXO modules	B.12-93
CCE 16 A	16 + ⊕	B.46	CSS 16 A	16 + ⊕	B.120	CX 04 T (4-slot sized MIXO frames)	B.93
CSH / JSH S 16 A	16 + ⊕	B.54 B.60	CT / CTSE* 16 A	16 + ⊕	B.126 B.132		
CSHT 16 A	16 + ⊕	B.67	CT / CTS* 10 A	40 + ⊕	B.138 B.140		
CQE / CQEY 16 A	32 + ⊕	B.74 B.84	CMCE / CMSH 16 A	6 + 2 (aux.) + ⊕	B.148 B.150		
CQEE 16 A	40 + ⊕	B.78	CX / CXC 80 A/16 A	4/0, 4/2 + ⊕	B.158-160		
CD 10 A	40 + ⊕	B.90	CX 40 A/10 A	6/12, 6/36, 9/42 and 12/2 + ⊕	B.163-164 B.168-169		
CDD 10 A	72 + ⊕	B.94					
CDSH 10 A	27 + ⊕	B.104					

*can be used only in bulkhead mounting housings

Accessories:

 **CGCP FX**
Dust protection cover
Page [G.47](#)

 **CGCP MB**
Dust protection cover
Page [G.47](#)

IP68 high protection series

Housings, hoods and covers – Bayonet locking

size **77.27**

Aggressive Environments

CE UK

CCC DNV VERITAS

EN 60529	IP66 / IP68 / IP69
UL 50 / UL 50E	Type 12 / 4 / 4X
Ambient temperature limits	-40 °C ... +125 °C
Mechanical life (cycles)	≥ 500

CAUS ECBT2.E115072 | ECBT8.E115072

Item	Description	Part No.	Entry	Dimension
	Bulkhead mounting housings, bayonet locking Optional mounting frame CG .. FL is available to ensure water tightness for bulkhead mounting housing when fitted onto a cabinet panel. (See page E.43)	CGI 16 B		
	Hoods, side entry, bayonet locking To be used only with a complete cable gland	MGO 16.32 B MGO 16.40 B MGO 16.50 B CGO 16.21 B CGO 16.29 B CGO 16.36 B	M32 M40 M50 Pg 21 Pg 29 Pg 36	
	Hoods, top entry, bayonet locking To be used only with a complete cable gland	MGV 16.25 B MGV 16.225 B MGV 16.32 B MGV 16.40 B MGV 16.50 B CGV 16.21 B CGV 16.221 B CGV 16.29 B CGV 16.36 B	M25 M25 x 2 M32 M40 M50 Pg 21 Pg 21 x 2 Pg 29 Pg 36	
	Covers, bayonet locking, for housings With loop	CGC 16 B		

IP68

E

Inserts size 77.27	Poles	Pages	Inserts size 77.27	Poles	Pages	MIXO Modular Inserts	Pages
CNE 16 A	16 + ⊕	E.40	CP / CPY 35 A	6 + ⊕	E.112 / E.114	MIXO modules	E.12-93
CCE 16 A	16 + ⊕	E.46	CSS 16 A	16 + ⊕	E.120	CX 04 T (4-slot sized MIXO frames)	E.95
CSH / JSH S 16 A	16 + ⊕	E.54 / E.61	CT / CTSE* 16 A	16 + ⊕	E.128 / E.132		
CSHT 16 A	16 + ⊕	E.67	CT / CTS* 10 A	40 + ⊕	E.138 / E.140		
CQE / CQEY 16 A	32 + ⊕	E.74 / E.84	CMCE / CMSH 16 A	6 + 2 (aux.) + ⊕	E.148 / E.150		
CQEE 16 A	40 + ⊕	E.78	CX / CXC 80 A/16 A	4/0, 4/2 + ⊕	E.158-160		
CD 10 A	40 + ⊕	E.90	CX 40 A/10 A	6/12, 6/36, 9/42 and 12/2 + ⊕	E.163-164 / E.168-169		
CDD 10 A	72 + ⊕	E.94					
CDSH 10 A	27 + ⊕	E.104					

*can be used only in bulkhead mounting housings

Accessories:

CGCP FX
Dust protection cover
Page [E.47](#)

CGCP MB
Dust protection cover
Page [E.47](#)

IP68 high protection series


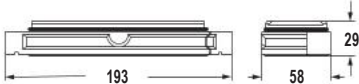

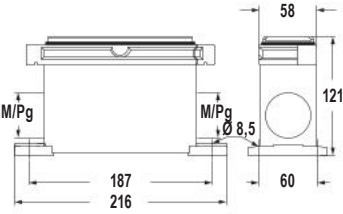

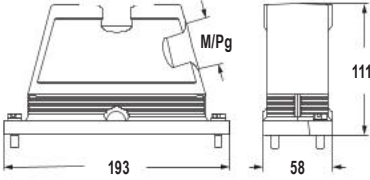

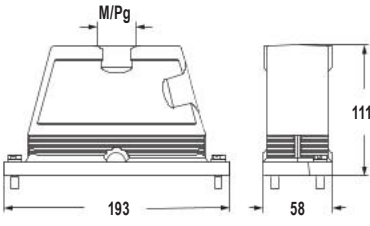


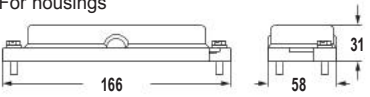
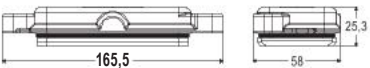
Housings, hoods and covers – Screw locking

size **104.27**



CAIUS ECBT2.E115072 | ECBT8.E115072

EN 60529	IP66 / IP68 / IP69
UL 50 / UL 50E	Type 12 / 4 / 4X
Ambient temperature limits	-40 °C ... +125 °C
Mechanical life (cycles)	≥ 500

Item	Description	Part No.	Entry	Dimension
	Bulkhead mounting housings, screw locking Optional mounting frame CG .. FL is available to ensure water tightness for bulkhead mounting housing when fitted onto a cabinet panel. (See page G.43)	CGI 24		
	Surface mounting housings, screw locking	MGP 24.40 MGP 24.240 CGP 24.36 CGP 24.236	M40 M40 x 2 Pg 36 Pg 36 x 2	
	Hoods, side entry, screw locking To be used only with a complete cable gland	MGO 24.32 MGO 24.40 MGO 24.50 CGO 24.21 CGO 24.29 CGO 24.36	M32 M40 M50 Pg 21 Pg 29 Pg 36	
	Hoods, top entry, screw locking To be used only with a complete cable gland	MGV 24.325 MGV 24.32 MGV 24.232 MGV 24.40 MGV 24.240 MGV 24.50 CGV 24.21 CGV 24.29 CGV 24.229 CGV 24.36	M25 x 3 M32 M32 x 2 M40 M40 x 2 M50 Pg 21 Pg 29 Pg 29 x 2 Pg 36	
	Covers, screw locking, for housings or for hoods With loop 	For housings CGC 24	For hoods CGC 24 G	For housings  For hoods 

Inserts size 104.27	Poles	Pages	Inserts size 104.27	Poles	Pages	MIXO Modular Inserts	Pages	
CNE 16 A	24 + ⊕	B.41	CSS 16 A	24 + ⊕	3.121	MIXO modules	C.12-93	
CCE 16 A	24 + ⊕	B.47	CT / CTSE* 16 A	24 + ⊕	3.129 3.133	CX 06 T (6-slot sized MIXO frames)	C.93	
CSH / JSH S 16 A	24 + ⊕	B.55 B.51	CT / CTS* 10 A	64 + ⊕	3.139 3.141			
CSHT 16 A	24 + ⊕	B.68	CMCE / CMSH 16 A	10 + 2 (aux.) + ⊕	3.146 3.151			
CQE / CQEY 16 A	46 + ⊕	B.75 B.83	CX 100 A/16 A	8/0 and 6/6 + ⊕	3.156-157			
CQEE 16 A	64 + ⊕	B.79	CX / CXC 80 A/16 A	4/8 + ⊕	3.161-162			
CD 10 A	64 + ⊕	B.91	*can be used only in bulkhead mounting housings					
CDD 10 A	108 + ⊕	B.97						
CDSH 10 A	42 + ⊕	B.103						

Accessories:

CGCP FX
Dust protection cover
Page [G.47](#)

CGCP MB
Dust protection cover
Page [G.47](#)

IP68 high protection series


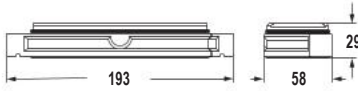

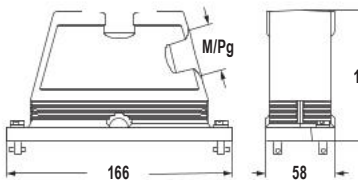

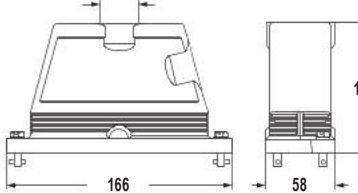


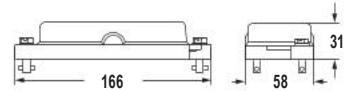
Housings, hoods and covers – Bayonet locking

size **104.27**
Aggressive Environments


EN 60529	IP66 / IP68 / IP69
UL 50 / UL 50E	Type 12 / 4 / 4X
Ambient temperature limits	-40 °C ... +125 °C
Mechanical life (cycles)	≥ 500



 ECBT2.E115072 | ECBT8.E115072

Item	Description	Part No.	Entry	Dimension
	Bulkhead mounting housings, bayonet locking Optional mounting frame CG .. FL is available to ensure water tightness for bulkhead mounting housing when fitted onto a cabinet panel. (See page E.43)	CGI 24 B		
	Hoods, side entry, bayonet locking To be used only with a complete cable gland	MGO 24.32 B MGO 24.40 B MGO 24.50 B CGO 24.21 B CGO 24.29 B CGO 24.36 B	M32 M40 M50 Pg 21 Pg 29 Pg 36	
	Hoods, top entry, bayonet locking To be used only with a complete cable gland	MGV 24.325 B MGV 24.32 B MGV 24.232 B MGV 24.40 B MGV 24.240 B MGV 24.50 B CGV 24.21 B CGV 24.29 B CGV 24.229 B CGV 24.36 B	M25 x 3 M32 M32 x 2 M40 M40 x 2 M50 Pg 21 Pg 29 Pg 29 x 2 Pg 36	
	Covers, bayonet locking, for housings With loop 	CGC 24 B		

Inserts size 104.27	Poles	Pages	Inserts size 104.27	Poles	Pages	MIXO Modular Inserts	Pages
CNE	16 A	24 + ⊕	E.41	CSS	16 A	24 + ⊕	E.121
CCE	16 A	24 + ⊕	E.47	CT / CTSE*	16 A	24 + ⊕	E.129 E.133
CSH / JSH S	16 A	24 + ⊕	E.55 E.61	CT / CTS*	10 A	64 + ⊕	E.133 E.141
CSHT	16 A	24 + ⊕	E.68	CMCE / CMSH	16 A	10 + 2 (aux.) + ⊕	E.146 E.151
CQE / CQEY	16 A	46 + ⊕	E.75 E.83	CX	100 A/16 A	8/0 and 6/6 + ⊕	E.156-157
CQEE	16 A	64 + ⊕	E.79	CX / CXC	80 A/16 A	4/8 + ⊕	E.161-162
CD	10 A	64 + ⊕	E.91	*can be used only in bulkhead mounting housings			
CDD	10 A	108 + ⊕	E.97				
CDSH	10 A	42 + ⊕	E.103				

Accessories:

CGCP FX
 Dust protection cover
 Page [E.47](#)

CGCP MB
 Dust protection cover
 Page [E.47](#)

Panel cut-out drawings

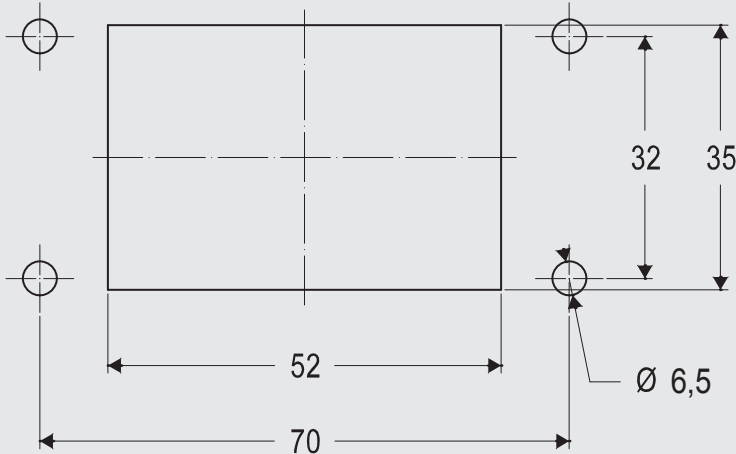
For IP68 series bulkhead mounting housings

To guarantee the declared IP degree of protection of the housings reported in this catalogue, according to EN IEC 60529 or to the relevant Type rating per ANSI/UL 50 and 50E (for those products bearing approval to those ratings), the surface of the mounting panel must meet the following requirements (definitions are provided in ISO 4287 standard):

Waviness Wt ≤ 0,2 mm over a distance of 200 mm (measured on the panel without load)
Roughness Ra ≤ 16 µm

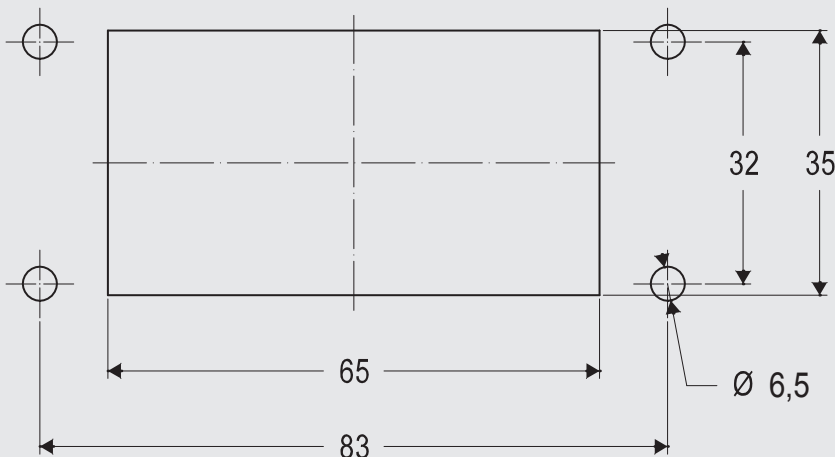
Scale 1:1

Size 44.27



Required screws: 4
Screws size: M6
Recommended torque:
 3,0 – 1,6 Nm / 26.6 – 31.9 lb.in

Size 57.27



Required screws: 4
Screws size: M6
Recommended torque:
 3,0 – 1,6 Nm / 26.6 – 31.9 lb.in

Notes: The values of tightening torque indicated above are just recommended values, that must be related – by the designer of the final application – to the resistance class of the screws (not included), with the assumption that the mounting panel is sufficiently rigid (stiff). If the deflection of the panel, under the effect of tightening the screws, is greater than 0,7 mm over a distance of 100 mm, it is necessary to use the counter-flanges mentioned in our catalogue or the special flange gaskets available upon request (please contact our Sales Department). For the CGI/MGI IP68 enclosures the specific counter-flanges mentioned in the catalogue are always recommended.

Accessories:



CG .. FL
Counterflanges for IP68
bulkhead mounting housings
 Page G.45

Panel cut-out drawings

For IP68 series bulkhead mounting housings

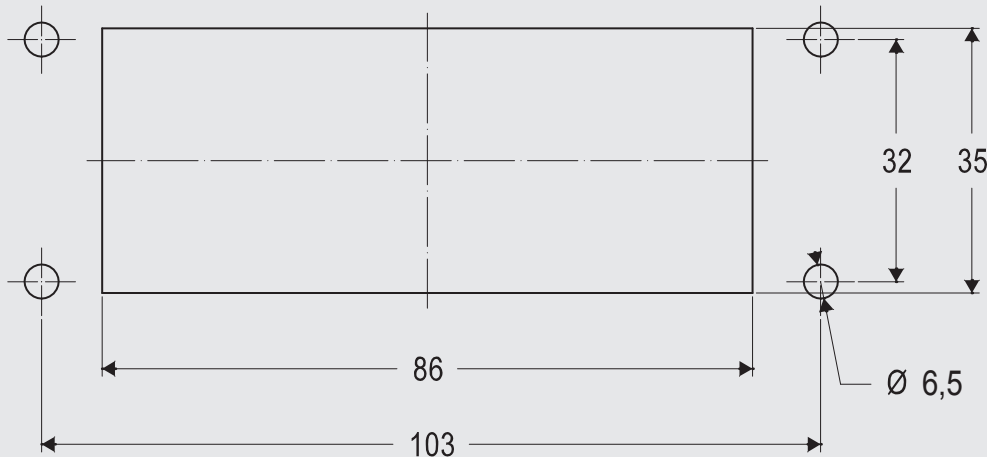
To guarantee the declared IP degree of protection of the housings reported in this catalogue, according to EN IEC 60529 or to the relevant Type rating per ANSI/UL 50 and 50E (for those products bearing approval to those ratings), the surface of the mounting panel must meet the following requirements (definitions are provided in ISO 4287 standard):

Waviness $Wt \leq 0,2$ mm over a distance of 200 mm
(measured on the panel without load)

Roughness $Ra \leq 16$ μ m

Scale 1:1

Size 77.27



Required screws: 4
Screws size: M6
Recommended torque:
3,0 – 1,6 Nm / 26.6 – 31.9 lb.in

Size 104.27



Required screws: 4
Screws size: M6
Recommended torque:
3,0 – 1,6 Nm / 26.6 – 31.9 lb.in

Notes: The values of tightening torque indicated above are just recommended values, that must be related – by the designer of the final application – to the resistance class of the screws (not included), with the assumption that the mounting panel is sufficiently rigid (stiff). If the deflection of the panel, under the effect of tightening the screws, is greater than 0,7 mm over a distance of 100 mm, it is necessary to use the counter-flanges mentioned in our catalogue or the special flange gaskets available upon request (please contact our Sales Department). For the CGI/MGI IP68 enclosures the specific counter-flanges mentioned in the catalogue are always recommended.

Accessories:



CG .. FL
Counterflanges for IP68
bulkhead mounting housings
Page G.45



W-TYPE series for aggressive environments



W-TYPE series

The W-Type enclosure series for aggressive environments is designed for industrial applications with particularly aggressive external agents.

The jet-black RAL 9005 colour identifies the series and, together with a pre-coating chromate conversion treatment RoHS 2 compliant, provides improved corrosion resistance in salt spray tests up to 500 hrs (according to UNI EN ISO 9227).



Watch our clip

SUM-UP

- > Made of die cast aluminium alloy.
- > Thermosetting epoxy powder coating, jet-black RAL 9005.
- > FKM fluoroelastomer gaskets (with improved resistance to chemicals and aging).
- > V-TYPE or C-TYPE locking device with self-extinguishing thermoplastic handles, springs and pins in stainless steel.
- > Hoods with stainless steel riveted pegs.
- > Ambient temperature range: -40 °C / +125 °C.

✔ Markings and Approvals

- CE and UKA markings, EAC not applicable
- UL certified for USA and Canada for Type 12, 4 and 4X degrees of protection (enclosure type ratings, equivalent to NEMA rating)
- IP66 / IP67 / IP69 degree of protection
- RoHS: compliant

FOCUS

Levers and technology

V-TYPE lever version

The V-TYPE closing principle consists of a **2-step movement**, thanks to the designed hinged elements pivoted on the housing: **the lever is moved above the housing pegs and then pressed downwards** to engage the locking mechanism.

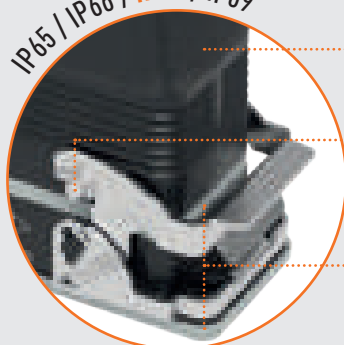
The tight seal after closure and the simplicity of the movement are the essential attributes that only ILME has managed to combine into a single lever.

C-TYPE lever version

The C-TYPE lever is a stainless steel lever with thermoplastic handles, designed to reduce the wear of the pegs on the hoods significantly, thanks to the presence of riveted rolls on a double spring mechanism.

The C-TYPE locking system provides smooth closure, resilience and compensation for any coupling tolerance.

IP65 / IP66 / IP67 / IP69



Thermosetting epoxy powder coating

Hoods with stainless steel riveted pegs

FKM fluoroelastomer gaskets with improved resistance to chemicals and aging

IP65 / IP66 / IP69



W-TYPE series – V-TYPE lever version

size **44.27**


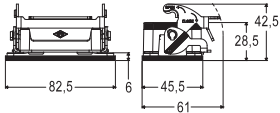

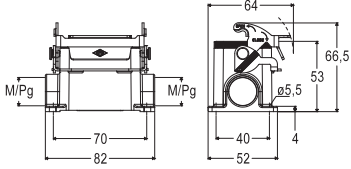

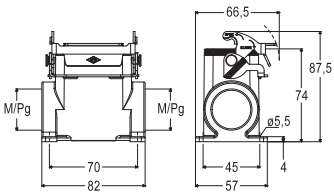
Housings – 1 lever – with gasket



EN 60529	IP65 / IP66 / IP67 / IP69
UL 50 / UL 50E	Type 12 / 4 / 4X
Ambient temperature limits	-40 °C ... +125 °C
Mechanical life (cycles)	≥ 500

DNV GL (pending: CQC)

CEC® ECBT2.E115072 | ECBT8.E115072

Item	Description	Part No.	Entry	Dimension
	<p>Bulkhead mounting housings, 1 lever and gasket, with or without metal cover</p> <p>Optional mounting frame CG .. FL is available to ensure water tightness for bulkhead mounting housing when fitted onto a cabinet panel. (See page G.45)</p>	C7IW 06 L		
	<p>Surface mounting housings, 1 lever and gasket, with or without metal cover</p>	M7PW 06 L32 M7PW 06 L232	M20 M20 x 2	
	<p>Surface mounting housings, 1 lever and gasket, with or without metal cover, high construction</p>	M7APW 06 L32 M7APW 06L232 M7APW 06 L40 M7APW 06L240	M32 M32 x 2 M40 M40 x 2	

W-TYPE

E

Inserts size 44.27	Poles	Pages	MIXO Modular Inserts	Pages
CNE	16 A 6 + ⊕	B.38	MIXO modules	C.12-93
CCE	16 A 6 + ⊕	B.44	CX 02 T (2-slot sized MIXO frames)	C.95
CSH / JSH S	16 A 6 + ⊕	B.52,58		
CQE / CQEY	16 A 10 + ⊕	B.72,82		
CDD	10 A 24 + ⊕	B.94		
CDSH / CDSH NC	10 A 9 and 6 + ⊕	B.102,108		
CSS	16 A 6 + ⊕	B.118		
CT / CTSE*	16 A 6 + ⊕	B.126,130		

*can be used only in bulkhead mounting housings

Accessories:



CHCP 06
Dust protection cover
Page G.46

W-TYPE series


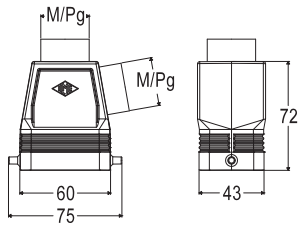

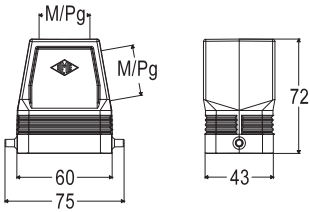

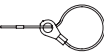
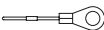
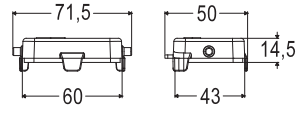
Hoods and covers – 2 pegs – without gasket

size **44.27**
Aggressive Environments

CE UK


EN 60529	IP65 / IP66 / IP69
UL 50 / UL 50E	Type 12 / 4 / 4X
Ambient temperature limits	-40 °C ... +125 °C
Mechanical life (cycles)	≥ 500

ALUS ECBT2.E115072 | ECBT8.E115072

Item	Description	Side entry	Top entry	Entry	Dimension
	Hoods, 2 pegs, without gasket, side or top entry, high construction, with metal adapter	MAOW 06 L32 CAOW 06 L21	MAVW 06 L32 CAVW 06 L21	M32 Pg 21	
	Hoods, 2 pegs, without gasket, side or top entry, high construction To be used only with a complete cable gland	MFOW 06 L32	MFVW 06 L32	M32	
	Covers, 2 pegs, without gasket For enclosures with 1 lever and gasket with loop for hoods  or with eyelet for housings 	With loop CHCW 06 SL	With eyelet CHCW 06 L		

Inserts size 44.27	Poles	Pages	MIXO Modular Inserts	Pages
CNE	16 A 6 + ⊕	B.38	MIXO modules	C.12-93
CCE	16 A 6 + ⊕	B.44	CX 02 T (2-slot sized MIXO frames)	C.95
CSH / JSH S	16 A 6 + ⊕	B.52,58		
CQE / CQEY	16 A 10 + ⊕	B.72,82		
CDD	10 A 24 + ⊕	B.94		
CDSH / CDSH NC	10 A 9 and 6 + ⊕	B.102,108		
CSS	16 A 6 + ⊕	B.118		

Accessories:

CHCP 06
Dust protection cover
Page G.46

W-TYPE series – V-TYPE lever version

size **57.27**


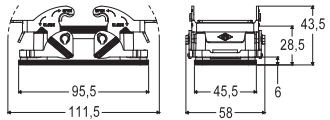

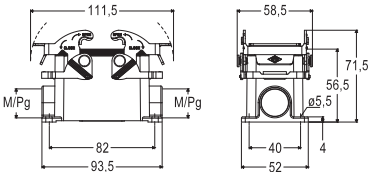

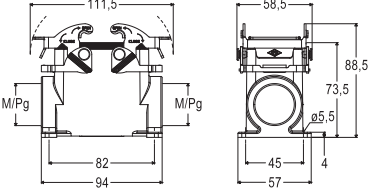
Housings – 2 levers – with gasket



EN 60529	IP65 / IP66 / IP67 / IP69
UL 50 / UL 50E	Type 12 / 4 / 4X
Ambient temperature limits	-40 °C ... +125 °C
Mechanical life (cycles)	≥ 500

DNV (pending: CQC)

CEBUS ECBT2.E115072 | ECBT8.E115072

Item	Description	Part No.	Entry	Dimension
	<p>Bulkhead mounting housings, 2 levers and gasket</p> <p>Optional mounting frame CG .. FL is available to ensure water tightness for bulkhead mounting housing when fitted onto a cabinet panel. (See page G.45)</p>	C7IW 10		
	Surface mounting housings, 2 levers and gasket	M7PW 10.20 M7PW 10.220	M20 M20 x 2	
	Surface mounting housings, 2 levers and gasket, high construction	M7APW 10.32 M7APW 10.232 M7APW 10.40 M7APW 10.240	M32 M32 x 2 M40 M40 x 2	

W-TYPE

E

Inserts size 57.27	Poles	Pages	Inserts size 57.27	Poles	Pages
CNE	16 A	10 + ⊕ B.39	CT / CTSE*	16 A	10 + ⊕ B.127,131
CCE	16 A	10 + ⊕ B.45	CMCE / CMSH	16 A	3 + 2 (aux.) + ⊕ B.144,149
CSH / JSH S	16 A	10 + ⊕ B.53,59	CX	40 A/10 A	8/24 + ⊕ B.170-171
CSHT	16 A	10 + ⊕ B.66	*can be used only in bulkhead mounting housings		
CQE / CQEY	16 A	18 + ⊕ B.73,83	MIXO Modular Inserts		
CDD	10 A	42 + ⊕ B.95	Pages		
CDSH	10 A	18 + ⊕ B.103	MIXO modules C.12-93		
CSS	16 A	10 + ⊕ B.119	CX 03 T (3-slot sized MIXO frames) C.95		

Accessories:



CHCP 10
Dust protection cover
Page G.46

W-TYPE series

Hoods and covers – 4 pegs – without gasket

size **57.27**
Aggressive Environments
CE UK


EN 60529	IP65 / IP66 / IP69
UL 50 / UL 50E	Type 12 / 4 / 4X
Ambient temperature limits	-40 °C ... +125 °C
Mechanical life (cycles)	≥ 500

CAIUS ECBT2.E115072 | ECBT8.E115072

Item	Description	Side entry	Top entry	Entry	Dimension
	Hoods, 4 pegs, without gasket, side or top entry, high construction	MAOW 10.32 CAOW 10.21	MAVW 10.32 CAVW 10.21	M32 Pg 21	
	Hoods, 4 pegs, without gasket, side or top entry, high construction To be used only with a complete cable gland	MFOW 10.32	MFVW 10.32	M32	
	Covers, 4 pegs, without gasket For enclosures with 2 levers and gasket with loop for hoods or with eyelet for housings	With loop CHCW 10 S	With eyelet CHCW 10		

Inserts size 57.27	Poles	Pages	Inserts size 57.27	Poles	Pages		
CNE	16 A	10 + ⊕	B.39	CMCE / CMSH	16 A	3 + 2 (aux.) + ⊕	B.144,149
CCE	16 A	10 + ⊕	B.45	CX	40 A/10 A	8/24 + ⊕	B.170-171
CSH / JSH S	16 A	10 + ⊕	B.53,59				
CSHT	16 A	10 + ⊕	B.66				
CQE / CQEY	16 A	18 + ⊕	B.73,83				
CDD	10 A	42 + ⊕	B.95				
CDSH	10 A	18 + ⊕	B.103				
CSS	16 A	10 + ⊕	B.119				
				MIXO Modular Inserts		Pages	
				MIXO modules		C.12-93	
				CX 03 T (3-slot sized MIXO frames)		C.95	

Accessories:

CHCP 10
 Dust protection cover
 Page G.46

W-TYPE series – V-TYPE lever version

size **77.27**


Housings – 2 levers – with gasket


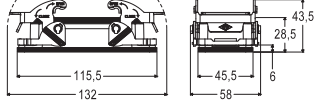

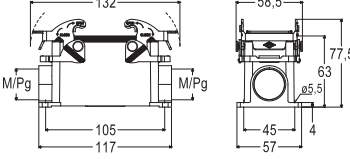

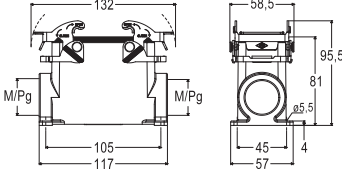
Aggressive Environments 

CE UK

EN 60529	IP65 / IP66 / IP67 / IP69
UL 50 / UL 50E	Type 12 / 4 / 4X
Ambient temperature limits	-40 °C ... +125 °C
Mechanical life (cycles)	≥ 500

 (pending: CQC)

 ECBT2.E115072 | ECBT8.E115072

Item	Description	Part No.	Entry	Dimension
	Bulkhead mounting housings, 2 levers and gasket Optional mounting frame CG .. FL is available to ensure water tightness for bulkhead mounting housing when fitted onto a cabinet panel. (See page G.45)	C7IW 16		
	Surface mounting housings, 2 levers and gasket	M7PW 16.25 M7PW 16.225	M25 M25 x 2	
	Surface mounting housings, 2 levers and gasket, high construction	M7APW 16.32 M7APW 16.232 M7APW 16.40 M7APW 16.240	M32 M32 x 2 M40 M40 x 2	

W-TYPE

E

Inserts size 77.27	Poles	Pages	Inserts size 77.27	Poles	Pages	MIXO Modular Inserts	Pages
CNE	16 + ⊕	B.40	CP / CPY	35 A	6 + ⊕	MIXO modules	C.12-93
CCE	16 A	B.46	CSS	16 A	16 + ⊕	CX 04 T (4-slot sized MIXO frames)	C.95
CSH / JSH S	16 A	B.54,60	CT / CTSE*	16 A	16 + ⊕		
CSHT	16 A	B.67	CT / CTS*	10 A	40 + ⊕		
CQE / CQEY	16 A	B.74,84	CMCE / CMSH	16 A	6 + 2 (aux.) + ⊕		
CQEE	16 A	B.78	CX / CXC	80 A/16 A	4/0, 4/2 + ⊕		
CD	10 A	B.90	CX	40 A/10 A	6/12, 6/36, 9/42 and 12/2 + ⊕		
CDD	10 A	B.94					
CDSH	10 A	B.104					

*can be used only in bulkhead mounting housings

Accessories:

 **CHCP 16**
Dust protection cover
Page G.46

W-TYPE series


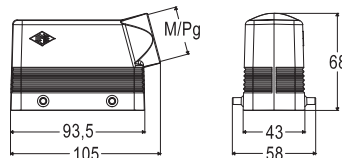

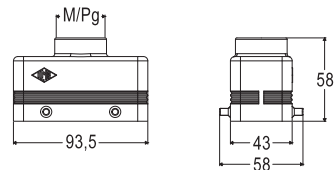

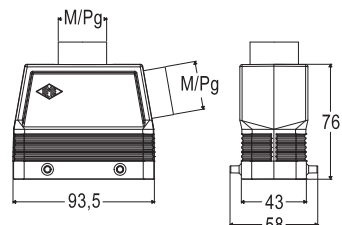

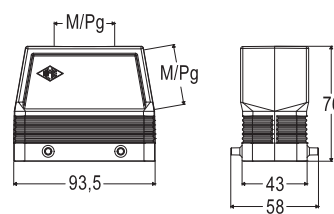


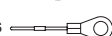
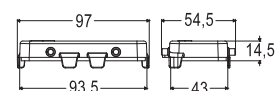
Hoods and covers – 4 pegs – without gasket

size **77.27**
Aggressive Environments

CE UK


EN 60529	IP65 / IP66 / IP69
UL 50 / UL 50E	Type 12 / 4 / 4X
Ambient temperature limits	-40 °C ... +125 °C
Mechanical life (cycles)	≥ 500

CALUS ECBT2.E115072 | ECBT8.E115072

Item	Description	Side entry	Top entry	Entry	Dimension
	Hoods, 4 pegs, without gasket, side entry	MHOW 16.25 MHOW 16.32 CHOW 16		M25 M32 Pg 21	
	Hoods, 4 pegs, without gasket, top entry To be used only with a complete cable gland		MHVW 16.25 MHVW 16.32 CHVW 16	M25 M32 Pg 21	
	Hoods, 4 pegs, without gasket, side or top entry, high construction	MAOW 16.32 MAOW 16.40 CAOW 16.29	MAVW 16.32 MAVW 16.40 CAVW 16.29	M32 M40 Pg 29	
	Hoods, 4 pegs, without gasket, side or top entry, high construction To be used only with a complete cable gland	MFOW 16.32 MFOW 16.40	MFVW 16.32 MFVW 16.40	M32 M40	
	Covers, 4 pegs, without gasket For enclosures with 2 levers and gasket with loop for hoods  or with eyelet for housings 	With loop CHCW 16 S	With eyelet CHCW 16		

W-TYPE

E

Inserts size 77.27	Poles	Pages	Inserts size 77.27	Poles	Pages	MIXO Modular Inserts	Pages
CNE	16 A	16 + ⊕ B.40	CP / CPY	35 A	6 + ⊕	B.112,114	
CCE	16 A	16 + ⊕ B.46	CSS	16 A	16 + ⊕	B.120	C.12-93
CSH / JSH S	16 A	16 + ⊕ B.54,60	CMCE / CMSH	16 A	6 + 2 (aux.) + ⊕	B.145,150	C.95
CSHT	16 A	16 + ⊕ B.67	CX / CXC	80 A/16 A	4/0, 4/2 + ⊕	B.158-160	
CQE / CQEY	16 A	32 + ⊕ B.74,84					
CQEE	16 A	40 + ⊕ B.78	CX	40 A/10 A	6/12, 6/36, 9/42 and 12/2 + ⊕	B.163-164, 168-169	
CD	10 A	40 + ⊕ B.90					
CDD	10 A	72 + ⊕ B.94					
CDSH	10 A	27 + ⊕ B.104					

Accessories:

CHCP 16
Dust protection cover
Page G.46

W-TYPE series – V-TYPE lever version

size **104.27**


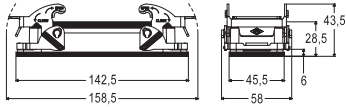

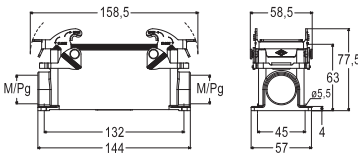

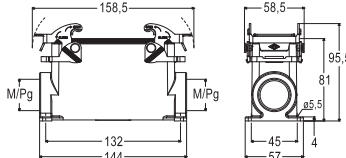
Housings – 2 levers – with gasket



EN 60529	IP65 / IP66 / IP67 / IP69
UL 50 / UL 50E	Type 12 / 4 / 4X
Ambient temperature limits	-40 °C ... +125 °C
Mechanical life (cycles)	≥ 500

DNV GL (pending: CQC)

CEC® ECBT2.E115072 | ECBT8.E115072

Item	Description	Part No.	Entry	Dimension
	Bulkhead mounting housings, 2 levers and gasket Optional mounting frame CG .. FL is available to ensure water tightness for bulkhead mounting housing when fitted onto a cabinet panel. (See page G.45)	C7IW 24		
	Surface mounting housings, 2 levers and gasket	M7PW 24.25 M7PW 24.225	M25 M25 x 2	
	Surface mounting housings, 2 levers and gasket, high construction	M7APW 24.32 M7APW 24.232 M7APW 24.40 M7APW 24.240	M32 M32 x 2 M40 M40 x 2	

W-TYPE

E

Inserts size 104.27	Poles	Pages	Inserts size 104.27	Poles	Pages	MIXO Modular Inserts	Pages
CNE	16 A	24 + ☉	B.41	CSS	16 A	24 + ☉	B.121
CCE	16 A	24 + ☉	B.47	CT / CTSE*	16 A	24 + ☉	B.129,133
CSH / JSH S	16 A	24 + ☉	B.55,61	CT / CTS*	10 A	64 + ☉	B.139,141
CSHT	16 A	24 + ☉	B.68	CMCE / CMSH	16 A	10 + 2 (aux.) + ☉	B.146,151
CQE / CQEY	16 A	46 + ☉	B.75,85	CX	100 A/16 A	8/0 and 6/6 + ☉	B.156-157
CQEE	16 A	64 + ☉	B.79	CX / CXC	80 A/16 A	4/8 + ☉	B.161-162
CD	10 A	64 + ☉	B.91	*can be used only in bulkhead mounting housings			
CDD	10 A	108 + ☉	B.97				
CDSH	10 A	42 + ☉	B.105				

Accessories:

CHCP 24
Dust protection cover
Page G.46



W-TYPE series


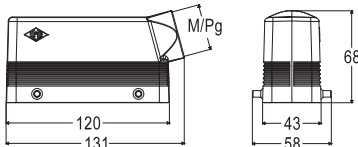

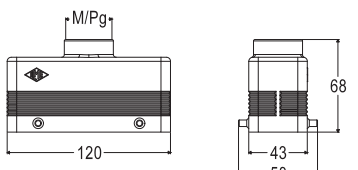

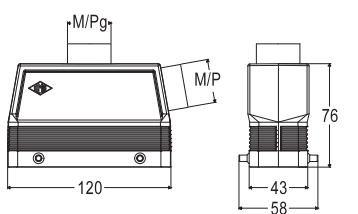

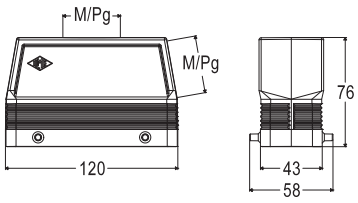


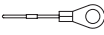
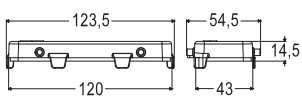
Hoods and covers – 4 pegs – without gasket

size **104.27**
Aggressive Environments

CE UK


EN 60529	IP65 / IP66 / IP69
UL 50 / UL 50E	Type 12 / 4 / 4X
Ambient temperature limits	-40 °C ... +125 °C
Mechanical life (cycles)	≥ 500

CALUS ECBT2.E115072 | ECBT8.E115072

Item	Description	Side entry	Top entry	Entry	Dimension
	Hoods, 4 pegs, without gasket, side entry	MHOW 24.25 MHOW 24.32 CHOW 24		M25 M32 Pg 21	
	Hoods, 4 pegs, without gasket, top entry To be used only with a complete cable gland		MHVW 24.25 MHVW 24.32 CHVW 24	M25 M32 Pg 21	
	Hoods, 4 pegs, without gasket, side or top entry, high construction	MAOW 24.32 MAOW 24.40 CAOW 24.29	MAVW 24.32 MAVW 24.40 CAVW 24.29	M32 M40 Pg 29	
	Hoods, 4 pegs, without gasket, side or top entry, high construction To be used only with a complete cable gland	MFOW 24.32 MFOW 24.40	MFVW 24.32 MFVW 24.40	M32 M40	
	Covers, 4 pegs, without gasket For enclosures with 2 levers and gasket with loop for hoods  or with eyelet for housings 	With loop CHCW 24 S	With eyelet CHCW 24		

Inserts size 104.27	Poles	Pages	Inserts size 104.27	Poles	Pages	MIXO Modular Inserts	Pages
CNE	16 A	24 + ⊕	B.41	CSS	16 A	24 + ⊕	B.121
CCE	16 A	24 + ⊕	B.47	CMCE / CMSH	16 A	10 + 2 (aux.) + ⊕	B.146,151
CSH / JSH S	16 A	24 + ⊕	B.55,61	CX	100 A/16 A	8/0 and 6/6 + ⊕	B.156-157
CSHT	16 A	24 + ⊕	B.68	CX / CXC	80 A/16 A	4/8 + ⊕	B.161-162
CQE / CQEY	16 A	46 + ⊕	B.75,85				
CQEE	16 A	64 + ⊕	B.79				
CD	10 A	64 + ⊕	B.91				
CDD	10 A	108 + ⊕	B.97				
CDSH	10 A	42 + ⊕	B.105				

Accessories:

CHCP 24
Dust protection cover
Page G.46

W-TYPE series – C-TYPE lever version

size **44.27**


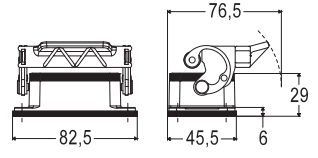

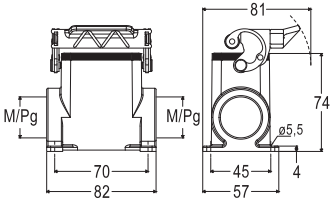

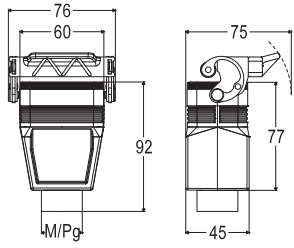

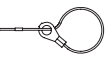
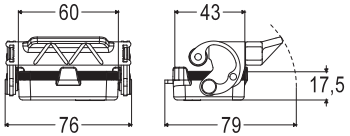
Housings and covers – 1 lever – with gasket



EN 60529	IP65 / IP66 / IP69
UL 50 / UL 50E	Type 12 / 4 / 4X
Ambient temperature limits	-40 °C ... +125 °C
Mechanical life (cycles)	≥ 500



CAUS® ECBT2.E115072 | ECBT8.E115072

Item	Description	Part No.	Entry	Dimension
	Bulkhead mounting housings, 1 lever and gasket	CHIW 06 L		
	Surface mounting housings, 1 lever and gasket, high construction	MAPW 06 L32 CAPW 06 L	M32 Pg 21	
	Hoods, 1 lever and gasket, top entry, high construction, with metal adapter	MAVW 06 LG32 CAVW 06 LG	M32 Pg 21	
	Covers, 1 lever and gasket For enclosures with 2 pegs without gasket with loop for hoods 	CHCW 06 LG		

W-TYPE
E

Inserts size 44.27	Poles	Pages	MIXO Modular Inserts	Pages
CNE	16 A 6 + ⊕	B.38	MIXO modules	C.12-93
CCE	16 A 6 + ⊕	B.44	CX 02 T (2-slot sized MIXO frames)	C.95
CSH / JSH S	16 A 6 + ⊕	B.52,58		
CQE / CQEY	16 A 10 + ⊕	B.72,82		
CDD	10 A 24 + ⊕	B.94		
CDSH / CDSH NC	10 A 9 and 6 + ⊕	B.102,108		
CSS	16 A 6 + ⊕	B.118		
CT / CTSE*	16 A 6 + ⊕	B.126,130		

Complete with:



Hoods
Page E.155



Covers
Page E.155

*can be used only in bulkhead mounting housings

W-TYPE series – C-TYPE lever version

size **57.27**


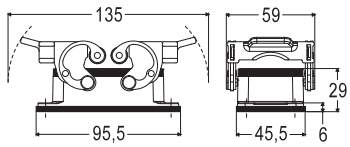

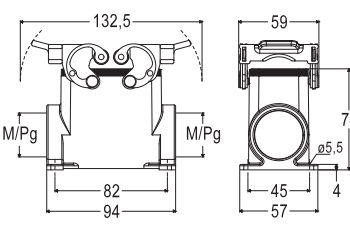

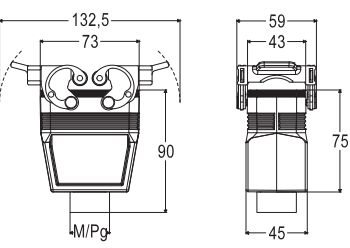

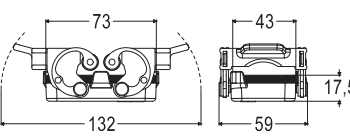
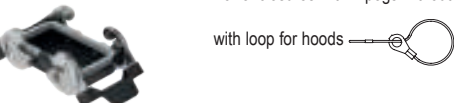
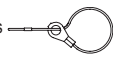
Housings and covers – 2 levers – with gasket

**Aggressive
Environments**

**CE UK
CA**

CEC ECBT2.E115072 | ECBT8.E115072

EN 60529	IP65 / IP66 / IP69
UL 50 / UL 50E	Type 12 / 4 / 4X
Ambient temperature limits	-40 °C ... +125 °C
Mechanical life (cycles)	≥ 500

Item	Description	Part No.	Entry	Dimension
	Bulkhead mounting housings, 2 levers and gasket	CHIW 10		
	Surface mounting housings, 2 levers and gasket, high construction	MAPW 10.32 CAPW 10.21	M32 Pg 21	
	Hoods, 2 levers and gasket, top entry, high construction, with metal adapter	MAVW 10 G32 CAVW 10 G	M32 Pg 21	
	Covers, 2 levers and gasket	CHCW 10 G		
	For enclosures with 4 pegs without gasket with loop for hoods 			

W-TYPE

E

Inserts size 57.27	Poles	Pages	Inserts size 57.27	Poles	Pages		
CNE	16 A	10 + ☉	B.39	CT / CTSE*	16 A	10 + ☉	B.127,131
CCE	16 A	10 + ☉	B.45	CMCE / CMSH	16 A	3 + 2 (aux.) + ☉	B.144,149
CSH / JSH S	16 A	10 + ☉	B.53,59	CX	40 A/10 A	8/24 + ☉	B.170-171
CSHT	16 A	10 + ☉	B.66	*can be used only in bulkhead mounting housings			
CQE / CQEY	16 A	18 + ☉	B.73,83				
CDD	10 A	42 + ☉	B.95				
CDSH	10 A	18 + ☉	B.103				
CSS	16 A	10 + ☉	B.119				
			MIXO Modular Inserts	Pages			
			MIXO modules	C.12-93			
			CX 03 T (3-slot sized MIXO frames)	C.95			

Complete with:


Hoods
Page E.157

Covers
Page E.157

W-TYPE series – C-TYPE lever version

size **77.27**

Housings and covers – 2 levers – with gasket



EN 60529	IP65 / IP66 / IP69
UL 50 / UL 50E	Type 12 / 4 / 4X
Ambient temperature limits	-40 °C ... +125 °C
Mechanical life (cycles)	≥ 500



CEBUS ECBT2.E115072 | ECBT8.E115072

Item	Description	Part No.	Entry	Dimension
	Bulkhead mounting housings, 2 levers and gasket	CHIW 16		
	Surface mounting housings, 2 levers and gasket, high construction	MAPW 16.32 CAPW 16.21	M32 Pg 21	
	Hoods, 2 levers and gasket, top entry, high construction, with metal adapter	MAVW 16 G32 CAVW 16 G29	M32 Pg 29	
	Covers, 2 levers and gasket For enclosures with 4 pegs without gasket with loop for hoods	CHCW 16 G		

W-TYPE

E

Inserts size 77.27	Poles	Pages	Inserts size 77.27	Poles	Pages	MIXO Modular Inserts	Pages
CNE	16 + ⊕	B.40	CP / CPY	35 A	6 + ⊕	MIXO modules	C.12-93
CCE	16 + ⊕	B.46	CSS	16 A	16 + ⊕	CX 04 T (4-slot sized MIXO frames)	C.95
CSH / JSH S	16 + ⊕	B.54,60	CT / CTSE*	16 A	16 + ⊕		
CSHT	16 + ⊕	B.67	CT / CTS*	10 A	40 + ⊕		
CQE / CQEY	16 A	32 + ⊕	CMCE / CMSH	16 A	6 + 2 (aux.) + ⊕		
CQEE	16 A	40 + ⊕	CX / CXC	80 A/16 A	4/0, 4/2 + ⊕		
CD	10 A	40 + ⊕	CX	40 A/10 A	6/12, 6/36, 9/42 and 12/2 + ⊕		
CDD	10 A	72 + ⊕					
CDSH	10 A	27 + ⊕					

*can be used only in bulkhead mounting housings

Complete with:

Hoods
Page E.159

Covers
Page E.159

W-TYPE series – C-TYPE lever version

size **104.27**


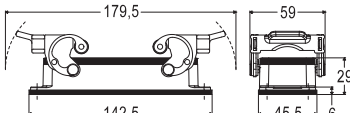

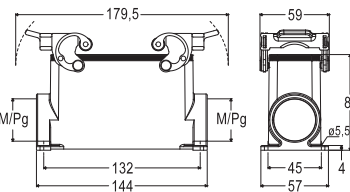

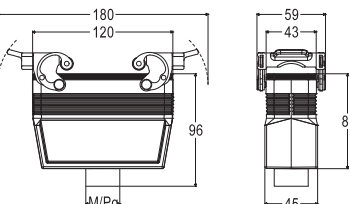

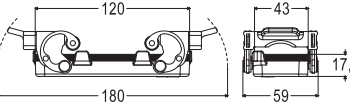

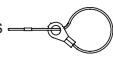
Housings and covers – 2 levers – with gasket

**Aggressive
Environments**

CE UK


EN 60529	IP65 / IP66 / IP69
UL 50 / UL 50E	Type 12 / 4 / 4X
Ambient temperature limits	-40 °C ... +125 °C
Mechanical life (cycles)	≥ 500

ALUS ECBT2.E115072 | ECBT8.E115072

Item	Description	Part No.	Entry	Dimension
	Bulkhead mounting housings, 2 levers and gasket	CHIW 24		
	Surface mounting housings, 2 levers and gasket, high construction	MAPW 24.32 CAPW 24.21	M32 Pg 21	
	Hoods, 2 levers and gasket, top entry, high construction, with metal adapter	MAVW 24 G32 CAVW 24 G	M32 Pg 21	
	Covers, 2 levers and gasket	CHCW 24 G		
	For enclosures with 4 pegs without gasket with loop for hoods 			

W-TYPE

E

Inserts size 104.27	Poles	Pages	Inserts size 104.27	Poles	Pages	MIXO Modular Inserts	Pages
CNE	16 A	24 + ⊕	B.41	CSS	16 A	24 + ⊕	B.121
CCE	16 A	24 + ⊕	B.47	CT / CTSE*	16 A	24 + ⊕	B.129,133
CSH / JSH S	16 A	24 + ⊕	B.55,61	CT / CTS*	10 A	64 + ⊕	B.139,141
CSHT	16 A	24 + ⊕	B.68	CMCE / CMSH	16 A	10 + 2 (aux.) + ⊕	B.146,151
CQE / CQEY	16 A	46 + ⊕	B.75,85	CX	100 A/16 A	8/0 and 6/6 + ⊕	B.156-157
CQEE	16 A	64 + ⊕	B.79	CX / CXC	80 A/16 A	4/8 + ⊕	B.161-162
CD	10 A	64 + ⊕	B.91	*can be used only in bulkhead mounting housings			
CDD	10 A	108 + ⊕	B.97				
CDSH	10 A	42 + ⊕	B.105				

Complete with:

Hoods
Page E.161

Covers
Page E.161

W-TYPE series

Housings, hoods and covers – 2 levers – with gasket

size **77.62**


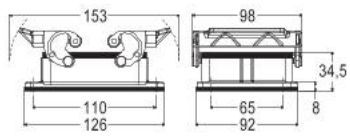

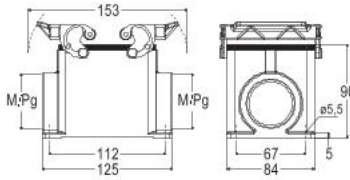

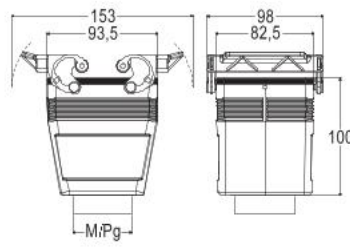


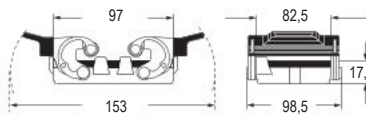
Aggressive Environments 

CE UK CA

CEC DNV VERITAS

EN 60529	IP65 / IP66 / IP69
UL 50 / UL 50E	Type 12 / 4 / 4X
Ambient temperature limits	-40 °C ... +125 °C
Mechanical life (cycles)	≥ 500

CEBUS ECBT2.E115072 | ECBT8.E115072

Item	Description	Part No.	Entry	Dimension
	Bulkhead mounting housings, 2 levers and gasket	CHIW 32		
	Surface mounting housings, 2 levers and gasket	MHPW 32.50 CHPW 32	M50 Pg 29	
	Hoods, 2 levers and gasket, top entry, with metal adapter	MHVW 32 G40 CHVW 32 G	M40 Pg 36	
	Covers, 2 levers and gasket For enclosures with 4 pegs without gasket with loop for hoods 	CHCW 32 G		

W-TYPE

E

Inserts size (77.27) × 2	Poles	Pages	Inserts size (77.27) × 2	Poles	Pages
CNE 16 A	32 + ⊕	3.42	CSS 16 A	32 + ⊕	3.122
CCE 16 A	32 + ⊕	3.43	CTSE* 16 A	32 + ⊕	3.134
CSH / JSH S 16 A	32 + ⊕	3.56 32	CMCE / CMSH 16 A	12 + 4 (aux.) + ⊕	3.147 152
CQE / CQEY 16 A	64 + ⊕	3.76 36	*can be used only in bulkhead mounting housings		
CD 10 A	80 + ⊕	3.92	MIXO Modular Inserts		
CDD 10 A	144 + ⊕	3.98	MIXO modules		
CDSH 10 A	54 + ⊕	3.106	CX 04 T (4-slot sized MIXO frames) × 2		
CP / CPY 35 A	12 + ⊕	3.113 115			

W-TYPE series

size **77.62**

Hoods and covers – 4 pegs – without gasket

Aggressive Environments
CE UK


EN 60529	IP65 / IP66 / IP69
UL 50 / UL 50E	Type 12 / 4 / 4X
Ambient temperature limits	-40 °C ... +125 °C
Mechanical life (cycles)	≥ 500

ALUS ECBT2.E115072 | ECBT8.E115072

Item	Description	Side entry	Top entry	Entry	Dimension
	Hoods, 4 pegs, without gasket, side or top entry, with metal adapter	MHOW 32.40 CHOW 32	MHVW 32.40 CHVW 32	M40 Pg 36	
	Covers, 4 pegs, without gasket	With loop CHCW 32 S	With eyelet CHCW 32		
	For enclosures with 2 levers and gasket				
	with loop for hoods				
	or				
	with eyelet for housings				

Inserts size (77.27) × 2	Poles	Pages	Inserts size (77.27) × 2	Poles	Pages
CNE	16 A	32 + ⊕ B.42	CSS	16 A	32 + ⊕ B.122
CCE	16 A	32 + ⊕ B.48	CMCE / CMSH	16 A	12 + 4 (aux.) + ⊕ B.147,152
CSH / JSH S	16 A	32 + ⊕ B.56,62			
CQE / CQEY	16 A	64 + ⊕ B.76,86			
CD	10 A	80 + ⊕ B.92			
CDD	10 A	144 + ⊕ B.98			
CDSH	10 A	54 + ⊕ B.106			
CP / CPY	35 A	12 + ⊕ B.113,115			
			MIXO Modular Inserts		Pages
			MIXO modules		C.12-93
			CX 04 T (4-slot sized MIXO frames) × 2		C.95

W-TYPE series

Housings – 1 lever – with gasket

size **104.62**


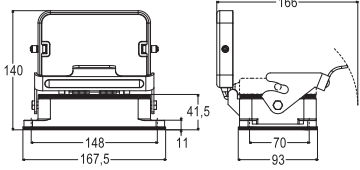

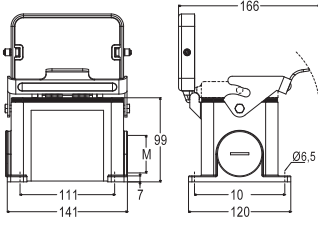
Aggressive Environments 

CE UK CA

EN 60529	IP65 / IP66 / IP69
UL 50 / UL 50E	Type 12 / 4 / 4X
Ambient temperature limits	-40 °C ... +125 °C
Mechanical life (cycles)	≥ 500



ALUS ECBT2.E115072 | ECBT8.E115072

Item	Description	Part No.	Entry	Dimension
	Bulkhead mounting housings, 1 stainless steel rigid lever and gasket, with metal cover	CHIW 48 LS		
	Surface mounting housings, 1 stainless steel rigid lever and gasket, with metal cover	MHPW 48 LS40 CHPW 48 LS	M40 × 2 Pg 36 × 2	

W-TYPE

E

Inserts size (104.27) × 2	Poles	Pages	Inserts size (104.27) × 2	Poles	Pages
CNE 16 A	48 + ⊕	B.43	CTSE* 16 A	48 + ⊕	B.135
CCE 16 A	48 + ⊕	B.49	CMCE / CMSH 16 A	10 + 2 (aux.) + ⊕	B.148,153
CSH / JSH S 16 A	48 + ⊕	B.57,63	*can be used only in bulkhead mounting housings		
CQE / CQEY 16 A	92 + ⊕	B.77,87			
CD 10 A	128 + ⊕	B.93			
CDD 10 A	216 + ⊕	B.99	MIXO Modular Inserts		Pages
CDSH 10 A	84 + ⊕	B.107	MIXO modules		C.12-93
CSS 16 A	48 + ⊕	B.123	CX 06 T (6-slot sized MIXO frames) × 2		C.95

W-TYPE series


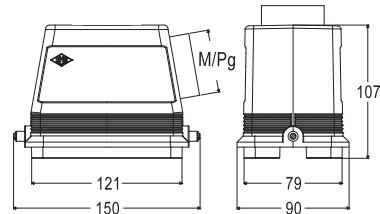

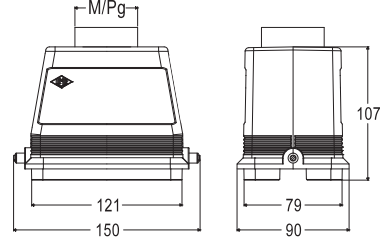

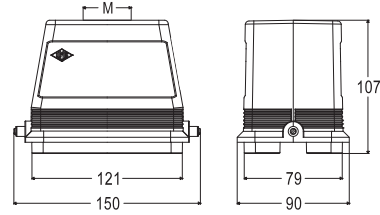
Hoods - 2 pegs - without gasket

size **104.62**
**Aggressive
Environments**

**CE UK
CA**


EN 60529	IP65 / IP66 / IP69
UL 50 / UL 50E	Type 12 / 4 / 4X
Ambient temperature limits	-40 °C ... +125 °C
Mechanical life (cycles)	≥ 500

CAUS ECBT2.E115072 | ECBT8.E115072

Item	Description	Side entry	Top entry	Entry	Dimension
	Hoods, 2 pegs, without gasket, side entry, with metal adapter	MHOW 48 L40 CHOW 48 L		M40 Pg 36	
	Hoods, 2 pegs, without gasket, top entry, with metal adapter		MHVW 48 L40 CHVW 48 L	M40 Pg 36	
	Hoods, 2 pegs, without gasket, top entry		MFVW 48 L63	M63	

W-TYPE

E

Inserts size (104.27) × 2	Poles	Pages	Inserts size (104.27) × 2	Poles	Pages
CNE 16 A	48 + ⊕	B.43	CMCE / CMSH 16 A	10 + 2 (aux.) + ⊕	B.148,153
CCE 16 A	48 + ⊕	B.49			
CSH / JSH S	48 + ⊕	B.57,63			
CQE / CQEY	92 + ⊕	B.77,87			
CD 10 A	128 + ⊕	B.93			
CDD 10 A	216 + ⊕	B.99			
CDSH 10 A	84 + ⊕	B.107			
CSS 16 A	48 + ⊕	B.123			
			MIXO Modular Inserts		Pages
			MIXO modules		C.12-93
			CX 06 T (6-slot sized MIXO frames) × 2		C.95

Panel cut-out drawings

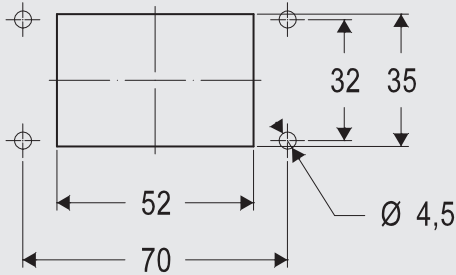
For W-TYPE series bulkhead mounting housings

To guarantee the declared IP degree of protection of the housings reported in this catalogue, according to EN IEC 60529 or to the relevant Type rating per ANSI/UL 50 and 50E (for those products bearing approval to those ratings), the surface of the mounting panel must meet the following requirements (definitions are provided in ISO 4287 standard):

Waviness $Wt \leq 0,2$ mm over a distance of 200 mm
(measured on the panel without load)
Roughness $Ra \leq 16$ μ m

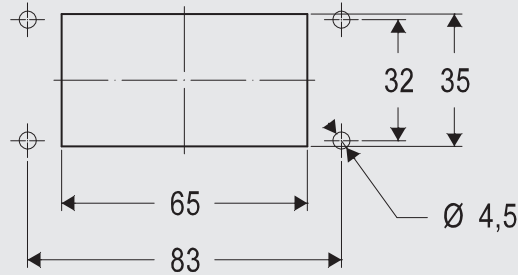
Scale 1:2

Size 44.27



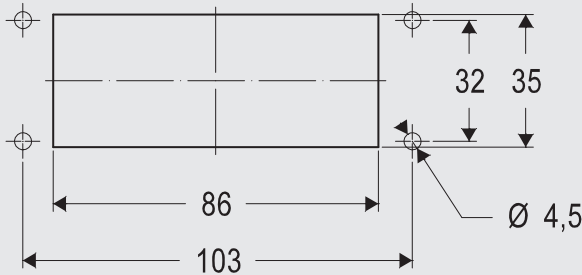
Required screws: 4
Screws size: M4
Recommended torque:
0,8 – 1,2 Nm / 7.1 – 10.6 lb.in

Size 57.27



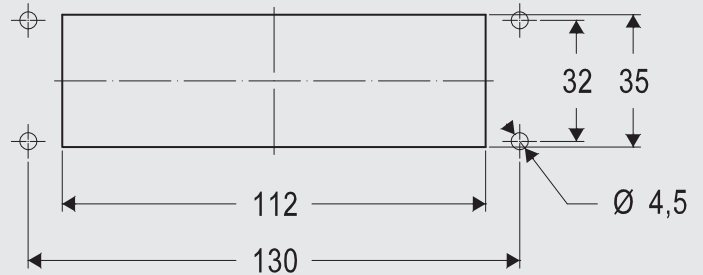
Required screws: 4
Screws size: M4
Recommended torque:
0,8 – 1,2 Nm / 7.1 – 10.6 lb.in

Size 77.27



Required screws: 4
Screws size: M4
Recommended torque:
0,8 – 1,2 Nm / 7.1 – 10.6 lb.in

Size 104.27



Required screws: 4
Screws size: M4
Recommended torque:
0,8 – 1,2 Nm / 7.1 – 10.6 lb.in

Notes: The values of tightening torque indicated above are just recommended values, that must be related – by the designer of the final application – to the resistance class of the screws (not included), with the assumption that the mounting panel is sufficiently rigid (stiff). If the deflection of the panel, under the effect of tightening the screws, is greater than 0,7 mm over a distance of 100 mm, it is necessary to use the counter-flanges mentioned in our catalogue or the special flange gaskets available upon request (please contact our Sales Department).

Accessories:



CG .. FL
Counterflanges for IP68
bulkhead mounting housings
Page G.45

Panel cut-out drawings

For W-TYPE series bulkhead mounting housings

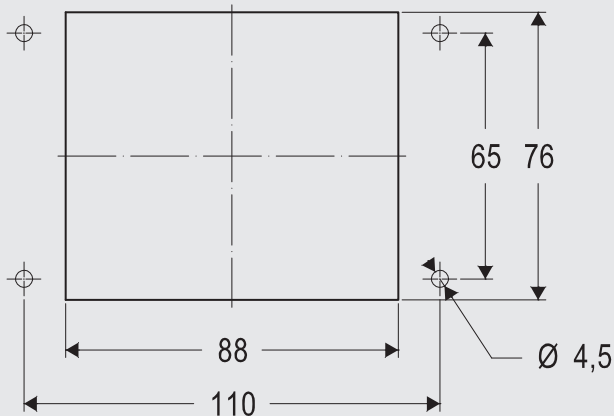
To guarantee the declared IP degree of protection of the housings reported in this catalogue, according to EN IEC 60529 or to the relevant Type rating per ANSI/UL 50 and 50E (for those products bearing approval to those ratings), the surface of the mounting panel must meet the following requirements (definitions are provided in ISO 4287 standard):

Waviness $Wt \leq 0,2$ mm over a distance of 200 mm
(measured on the panel without load)

Roughness $Ra \leq 16$ μ m

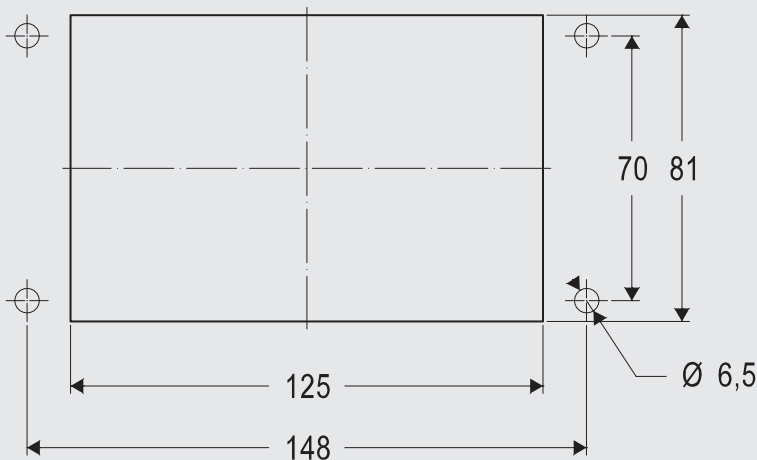
Scale 1:2

Size 77.62



Required screws: 4
Screws size: M4
Recommended torque:
1,2 – 1,8 Nm / 10.6 – 15.9 lb.in

Size 104.62



Required screws: 4
Screws size: M6
Recommended torque:
3,0 – 3,6 Nm / 26.6 – 31.9 lb.in

Notes: The values of tightening torque indicated above are just recommended values, that must be related – by the designer of the final application – to the resistance class of the screws (not included), with the assumption that the mounting panel is sufficiently rigid (stiff). If the deflection of the panel, under the effect of tightening the screws, is greater than 0,7 mm over a distance of 100 mm, it is necessary to use the counter-flanges mentioned in our catalogue or the special flange gaskets available upon request (please contact our Sales Department).

Accessories:



CG .. FL
Counterflanges for IP68
bulkhead mounting housings
Page G.45



E-Xtreme® series

Protection and beyond



E-Xtreme® series enclosures

E-Xtreme® series hoods and housings are intended for highly demanding environments.

The unique patented protective coating applied before the coating guarantees maximum protection against pollution, erosion and long-term exposure to corrosive agents.

SUM-UP

- > Made of die cast aluminium alloy, epoxy powder coated, dark grey RAL 7016.
- > FKM gasket (IP68 series with NBR gasket or silicone gasket upon request).
- > Temperature range:
 - enclosures with V-TYPE lever: -40 °C...+125 °C* (-60 °C...+125 °C* with silicone gasket)
 - enclosures with C-TYPE lever: -40 °C...+125 °C* (-60 °C...+125 °C* with silicone gasket)
 - enclosures with IP-68 locking system: -40 °C...+125 °C* (-60 °C...+125 °C* with silicone gasket)

* (>125 °C up to 180 °C with RY inserts)

✔ Markings and Approvals

- CE and UKA markings, EAC not applicable
- UL certified for USA and Canada for Type 12, 4 and 4X degrees of protection (enclosure type ratings, equivalent to NEMA rating)
- IP66 / IP67 / IP69 degree of protection, IP66 / IP68 / IP69 for IP68 series.
- RoHS: compliant



Watch our clip

TECHNICAL FEATURES

Levers and technology

- V-TYPE lever** IP65 / IP67 / IP69: the V-type closing principle consists of a two-step movement, thanks to the designed hinged elements pivoted on the housing: the lever is moved above the housing pegs and then pressed downwards to engage the locking mechanism.
- C-TYPE lever** IP65 / IP66 / IP69: stainless steel lever with thermoplastic handles, designed to reduce the wear of the pegs on the hoods significantly, thanks to the presence of riveted rolls on a double spring mechanism. The C-TYPE locking system provides smooth closure, resilience, and compensation for any coupling tolerance.
- Corrosion-proof** aluminium with a special coating under the powder painting colour RAL 7016 dark grey.
- FKM**: Fluoroelastomer gasket (with improved resistance to chemicals and aging).
- Hoods with moulded pegs or riveted stainless-steel bolts.

2 000 hrs resistance
in salt spray tests

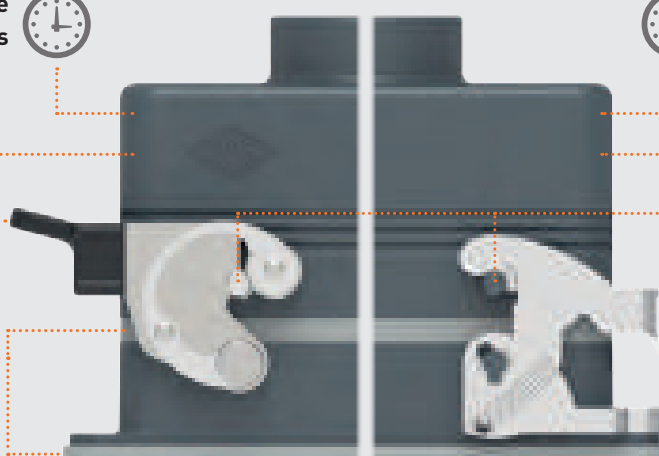


3

2

C-TYPE

4



3 000 hrs resistance
in salt spray tests



3

5

V-TYPE



Icing

Very low
temperaturesSalt
mistImpact
resistantUV
radiationsChemical
resistant

Applicable test standards

EN 61984:2009-06	Connectors - Safety requirements and tests
EN 60529: 1991 + A1: 2000 + A2: 2013	Degrees of protection provided by enclosures (IP code)
EN ISO 9227: 2012	Corrosion tests in artificial atmospheres - Salt spray tests
EN 61373 cat. 1B, 3 axis	Vibration test / Shock test
EN 60068-2-6	10÷500 Hz 0,35mm/5g break point 60, 1 Hz 3 axis
ASTM B117-16	Standard practice for operating salt spray (fog) apparatus
EN 60512 (series)	Connectors for electronic equipment - Tests and measurement
EN 60068-2-68: 1996	Environmental testing - Part 2-68: Tests - Test L: Dust and sand
EN ISO 20567-1: 2005	Paints and varnishes -- Determination of stone-chip resistance of coatings -- Part 1: Multi-impact testing

E-Xtreme® – V-TYPE lever version

Housings – 1 lever – with gasket

size **44.27**

3 000 hrs resistance
in salt-spray tests



Aggressive
Environments




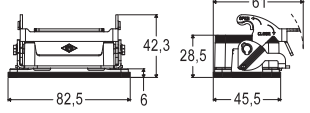


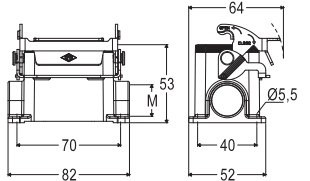


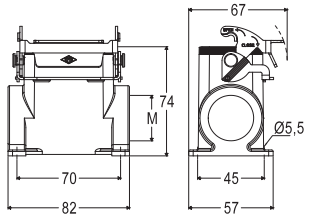
EN 60529	IP66 / IP67 / IP69
UL 50 / UL 50E	Type 12 / 4 / 4X
Ambient temperature limits	-40 °C ... +125 °C*
with silicone gasket (on request)	-60 °C ... +125 °C*
Mechanical life (cycles)	≥ 500

*(>125 °C up to 180 °C with RY inserts)



DNV VERITAS (pending: CQC)

CANUS ECBT2.E115072 | ECBT8.E115072

Item	Description	Part No.	Entry	Dimension
	Bulkhead mounting housings, 1 lever and gasket Optional mounting frame CG .. FL is available to ensure water tightness for bulkhead mounting housing when fitted onto a cabinet panel. (See page G.45)	C7IE 06 L		
	Surface mounting housings, 1 lever and gasket,  2 000 hrs	M7PE 06 L20 M7PE 06 L220	M20 M20 × 2	
	Surface mounting housings, 1 lever and gasket, high construction  2 000 hrs	M7APE 06 L32 M7APE 06L232 M7APE 06 L40 M7APE 06L240	M32 M32 × 2 M40 M40 × 2	

Inserts size 44.27	Poles	Pages	MIXO Modular Inserts	Pages
CNE 16 A	6 + ⊕	B.38	MIXO modules	C.12-93
CCE 16 A	6 + ⊕	B.44	CX 02 T (2-slot sized MIXO frames)	C.95
CSH / JSH S	16 A	6 + ⊕		
CQE / CQEY	16 A	10 + ⊕		
CDD 10 A	24 + ⊕	B.94		
CDSH / CDSH NC	10 A	9 and 6 + ⊕		
CSS 16 A	6 + ⊕	B.118		
CT / CTSE*	16 A	6 + ⊕		

180 °C Inserts size 44.27	Poles	Pages
CNE RY**	16 A	6 + ⊕

** >125 °C up to 180 °C

*can be used only in bulkhead mounting housings

E-Xtreme® – V-TYPE lever version

size **44.27**

Hoods – 2 pegs – without gasket

3 000 hrs resistance
 in salt-spray tests


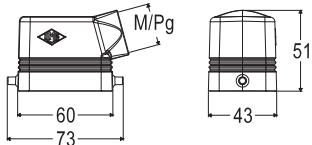

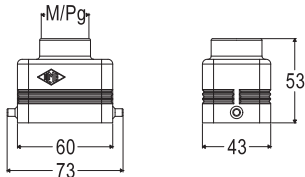

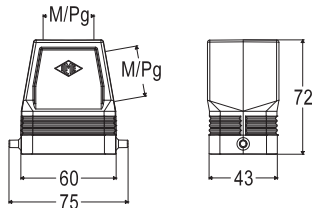
Aggressive
Environments


EN 60529	IP66 / IP67 / IP69
UL 50 / UL 50E	Type 12 / 4 / 4X
Ambient temperature limits	-40 °C ... +125 °C*
with silicone gasket (on request)	-60 °C ... +125 °C*
Mechanical life (cycles)	≥ 500

*(>125 °C up to 180 °C with RY inserts)

CE UK


 C[®]ALUS ECBT2.E115072 | ECBT8.E115072

Item	Description	Side entry	Top entry	Entry	Dimension
	Hoods, 2 pegs, side entry	MHOE 06 L20M MHOE 06 L25M		M20 M25	
	Hoods, 2 pegs, top entry To be used only with a complete cable gland		MHVE 06 L20M MHVE 06 L25M	M20 M25	
	Hoods, 2 pegs, side or top entry, high construction To be used only with a complete cable gland	MFOE 06 L32M MFOE 06 L40M	MFVE 06 L32M MFVE 06 L40M	M32 M40	

E-Xtreme®

E

Inserts size 44.27	Poles	Pages	MIXO Modular Inserts	Pages
CNE 16 A	6 + ⊕	B.38	MIXO modules	C.12-93
CCE 16 A	6 + ⊕	B.44	CX 02 T (2-slot sized MIXO frames)	C.95
CSH / JSH S	6 + ⊕	B.52,58		
CQE / CQEY	10 + ⊕	B.72,82		
CDD 10 A	24 + ⊕	B.94		
CDSH / CDSH NC	10 A	9 and 6 + ⊕	B.102,108	
CSS 16 A	6 + ⊕	B.118		
			180 °C Inserts size 44.27	Poles Pages
			CNE RY**	16 A 6 + ⊕ I.5

** >125 °C up to 180 °C

E-Xtreme® – V-TYPE lever version

Housings – 2 levers – with gasket

size **57.27**

3 000 hrs resistance
in salt-spray tests



Aggressive
Environments




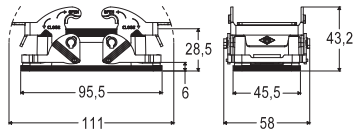


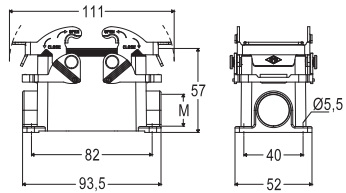


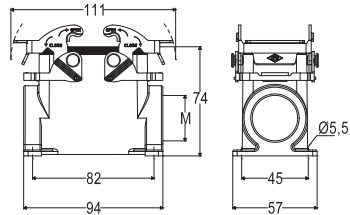
EN 60529	IP66 / IP67 / IP69
UL 50 / UL 50E	Type 12 / 4 / 4X
Ambient temperature limits with silicone gasket (on request)	-40 °C ... +125 °C*
Mechanical life (cycles)	-60 °C ... +125 °C* ≥ 500

*(>125 °C up to 180 °C with RY inserts)



DNV VERITAS (pending: CQC)

CEBUS ECBT2.E115072 | ECBT8.E115072

Item	Description	Part No.	Entry	Dimension
	Bulkhead mounting housings, 2 levers and gasket Optional mounting frame CG .. FL is available to ensure water tightness for bulkhead mounting housing when fitted onto a cabinet panel. (See page G.45)	C7IE 10		
	Surface mounting housings, 2 levers and gasket  2 000 hrs	M7PE 10.20 M7PE 10.220	M20 M20 × 2	
	Surface mounting housings, 2 levers and gasket, high construction  2 000 hrs	M7APE 10.32 M7APE 10.232 M7APE 10.40 M7APE 10.240	M32 M32 × 2 M40 M40 × 2	

Inserts size 57.27	Poles	Pages	Inserts size 57.27	Poles	Pages	180 °C Inserts size 57.27	Poles	Pages			
CNE	16 A	10 + ⊕	B.39	CT / CTSE*	16 A	10 + ⊕	B.127,131	CNE RY**	16 A	10 + ⊕	I.6
CCE	16 A	10 + ⊕	B.45	CMCE / CMSH	16 A	3 + 2 (aux.) + ⊕	B.144,149	** >125 °C up to 180 °C			
CSH / JSH S	16 A	10 + ⊕	B.53,59	CX	40 A/10 A	8/24 + ⊕	B.170-171				
CSHT	16 A	10 + ⊕	B.66	*can be used only in bulkhead mounting housings							
CQE / CQEY	16 A	18 + ⊕	B.73,83								
CDD	10 A	42 + ⊕	B.95	MIXO Modular Inserts							
CDSH	10 A	18 + ⊕	B.103	MIXO modules							
CSS	16 A	10 + ⊕	B.119	CX 03 T (3-slot sized MIXO frames)							
					Pages						
					C.12-93						
					C.95						

E-Xtreme® – V-TYPE lever version

size **57.27**

Hoods – 4 pegs – without gasket

3 000 hrs resistance
 in salt-spray tests


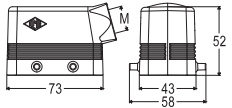

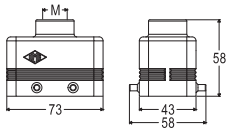

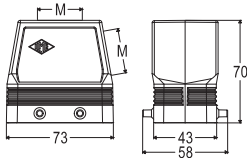
Aggressive Environments


EN 60529	IP66 / IP67 / IP69
UL 50 / UL 50E	Type 12 / 4 / 4X
Ambient temperature limits	-40 °C ... +125 °C*
with silicone gasket (on request)	-60 °C ... +125 °C*
Mechanical life (cycles)	≥ 500

*(>125 °C up to 180 °C with RY inserts)



ECBT2.E115072 | ECBT8.E115072

Item	Description	Side entry	Top entry	Entry	Dimension
	Hoods, 4 pegs, side entry	MHOE 10.20M MHOE 10.25M		M20 M25	
	Hoods, 4 pegs, top entry To be used only with a complete cable gland		MHVE 10.20M MHVE 10.25M	M20 M25	
	Hoods, 4 pegs, side or top entry, high construction To be used only with a complete cable gland	MFOE 10.32M MFOE 10.40M	MFVE 10.32M MFVE 10.40M	M32 M40	

E-Xtreme®

E

Inserts size 57.27	Poles	Pages	Inserts size 57.27	Poles	Pages	180 °C Inserts size 57.27	Poles	Pages			
CNE	16 A	10 + ⊕	B.39	CMCE / CMSH	16 A	3 + 2 (aux.) + ⊕	B.144,149	CNE RY**	16 A	10 + ⊕	I.6
CCE	16 A	10 + ⊕	B.45	CX	40 A/10 A	8/24 + ⊕	B.170-171	** >125 °C up to 180 °C			
CSH / JSH S	16 A	10 + ⊕	B.53,59								
CSHT	16 A	10 + ⊕	B.66								
CQE / CQEY	16 A	18 + ⊕	B.73,83								
CDD	10 A	42 + ⊕	B.95	MIXO Modular Inserts		Pages					
CDSH	10 A	18 + ⊕	B.103	MIXO modules		C.12-93					
CSS	16 A	10 + ⊕	B.119	CX 03 T (3-slot sized MIXO frames)		C.95					

E-Xtreme® – V-TYPE lever version

Housings – 2 levers – with gasket

size **77.27**

3 000 hrs resistance
in salt-spray tests



Aggressive
Environments




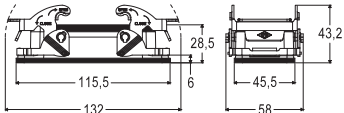

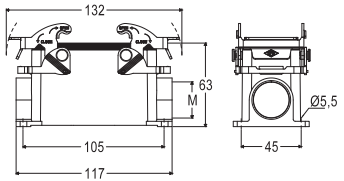

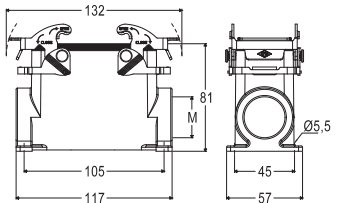
EN 60529	IP66 / IP67 / IP69
UL 50 / UL 50E	Type 12 / 4 / 4X
Ambient temperature limits with silicone gasket (on request)	-40 °C ... +125 °C*
Mechanical life (cycles)	-60 °C ... +125 °C* ≥ 500

*(>125 °C up to 180 °C with RY inserts)



DNV (pending: CQC)

ECBT2.E115072 | ECBT8.E115072

Item	Description	Part No.	Entry	Dimension
	Bulkhead mounting housings, 2 levers and gasket Optional mounting frame CG .. FL is available to ensure water tightness for bulkhead mounting housing when fitted onto a cabinet panel. (See page G.45)	C7IE 16		
	Surface mounting housings, 2 levers and gasket	M7PE 16.25 M7PE 16.225	M25 M25 × 2	
	Surface mounting housings, 2 levers and gasket, high construction	M7APE 16.32 M7APE 16.232 M7APE 16.40 M7APE 16.240	M32 M32 × 2 M40 M40 × 2	

2 000 hrs

2 000 hrs

E-Xtreme®

E

Inserts size 77.27	Poles	Pages	Inserts size 77.27	Poles	Pages	MIXO Modular Inserts	Pages
CNE 16 A	16 + ⊕	B.40	CP / CPY 35 A	6 + ⊕	B.112,114	MIXO modules	C.12-93
CCE 16 A	16 + ⊕	B.46	CSS 16 A	16 + ⊕	B.120	CX 04 T (4-slot sized MIXO frames)	C.95
CSH / JSH S 16 A	16 + ⊕	B.54,60	CT / CTSE* 16 A	16 + ⊕	B.128,132		
CSHT 16 A	16 + ⊕	B.67	CT / CTS* 10 A	40 + ⊕	B.138,140		
CQE / CQEY 16 A	32 + ⊕	B.74,84	CMCE / CMSH 16 A	6 + 2 (aux.) + ⊕	B.145,150		
CQEE 16 A	40 + ⊕	B.78	CX / CXC 80 A/16 A	4/0, 4/2 + ⊕	B.158-160		
CD 10 A	40 + ⊕	B.90	CX 40 A/10 A	6/12, 6/36, 9/42 and 12/2 + ⊕	B.163-164, 168-169		
CDD 10 A	72 + ⊕	B.94					
CDSH 10 A	27 + ⊕	B.104					

*can be used only in bulkhead mounting housings

** >125 °C up to 180 °C

E-Xtreme® – V-TYPE lever version

size **77.27**

Hoods – 4 pegs – without gasket

3 000 hrs resistance
 in salt-spray tests

Aggressive Environments


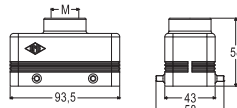


EN 60529	IP66 / IP67 / IP69
UL 50 / UL 50E	Type 12 / 4 / 4X
Ambient temperature limits	-40 °C ... +125 °C*
with silicone gasket (on request)	-60 °C ... +125 °C*
Mechanical life (cycles)	≥ 500

*(>125 °C up to 180 °C with RY inserts)

CE UK



ECBT2.E115072 | ECBT8.E115072

Item	Description	Side entry	Top entry	Entry	Dimension
	Hoods, 4 pegs, side entry	MHOE 16.25M MHOE 16.32M		M25 M32	
	Hoods, 4 pegs, top entry To be used only with a complete cable gland		MHVE 16.25M MHVE 16.32M	M25 M32	
	Hoods, 4 pegs, side or top entry, high construction To be used only with a complete cable gland	MFOE 16.32M MFOE 16.40M	MFVE 16.32M MFVE 16.40M	M32 M40	

E-Xtreme®

E

Inserts size 77.27	Poles	Pages	Inserts size 77.27	Poles	Pages	MIXO Modular Inserts	Pages		
CNE	16 A	16 + ⊕ B.40	CP / CPY	35 A	6 + ⊕	B.112,114	C.12-93		
CCE	16 A	16 + ⊕ B.46	CSS	16 A	16 + ⊕	B.120	CX 04 T (4-slot sized MIXO frames)	C.95	
CSH / JSH S	16 A	16 + ⊕ B.54,60	CMCE / CMSH	16 A	6 + 2 (aux.) + ⊕	B.145,150			
CST	16 A	16 + ⊕ B.67	CX / CXC	80 A/16 A	4/0, 4/2 + ⊕	B.158-160			
CQE / CQEY	16 A	32 + ⊕ B.74,84	CX	40 A/10 A	6/12, 6/36, 9/42 and 12/2 + ⊕	B.163-164, 168-169	180 °C Inserts size 77.27	Poles	Pages
CQEE	16 A	40 + ⊕ B.78					CNE RY**	16 A	16 + ⊕
CD	10 A	40 + ⊕ B.90				CP RY**	35 A	6 + ⊕	I.10
CDD	10 A	72 + ⊕ B.94				CX RY**	80 A	4 + ⊕	I.11
CDSH	10 A	27 + ⊕ B.104				CX RY**	80 A/16 A	4/2 + ⊕	I.12

** >125 °C up to 180 °C

dimensions shown in mm are not binding and may be changed without notice

E.179

E-Xtreme® – V-TYPE lever version

Housings – 2 levers – with gasket

size **104.27**

3 000 hrs resistance
in salt-spray tests



Aggressive
Environments




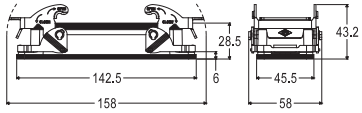

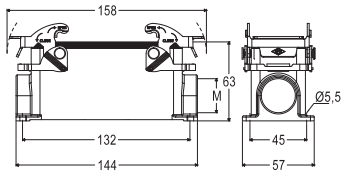


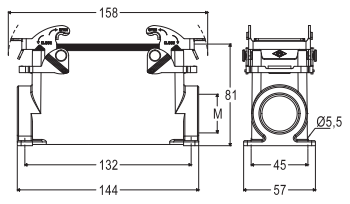

EN 60529	IP66 / IP67 / IP69
UL 50 / UL 50E	Type 12 / 4 / 4X
Ambient temperature limits with silicone gasket (on request)	-40 °C ... +125 °C*
Mechanical life (cycles)	-60 °C ... +125 °C* ≥ 500

*(>125 °C up to 180 °C with RY inserts)

CE UK

DNV VERITAS (pending: CQC)

CAIUS ECBT2.E115072 | ECBT8.E115072

Item	Description	Part No.	Entry	Dimension
	Bulkhead mounting housings, 2 levers and gasket Optional mounting frame CG .. FL is available to ensure water tightness for bulkhead mounting housing when fitted onto a cabinet panel. (See page G.45)	C7IE 24		
	Surface mounting housings, 2 levers and gasket	M7PE 24.25 M7PE 24.225	M25 M25 × 2	
	 2 000 hrs			
	Surface mounting housings, 2 levers and gasket, high construction	M7APE 24.32 M7APE 24.232 M7APE 24.40 M7APE 24.240	M32 M32 × 2 M40 M40 × 2	
	 2 000 hrs			

E-Xtreme®

E

Inserts size 104.27	Poles	Pages	Inserts size 104.27	Poles	Pages	MIXO Modular Inserts	Pages
CNE	16 A	24 + ⊕	B.41	CSS	16 A	24 + ⊕	B.121
CCE	16 A	24 + ⊕	B.47	CT / CTSE*	16 A	24 + ⊕	B.129,133
CSH / JSH S	16 A	24 + ⊕	B.55,61	CT / CTS*	10 A	64 + ⊕	B.139,141
CSHT	16 A	24 + ⊕	B.68	CMCE / CMSH	16 A	10 + 2 (aux.) + ⊕	B.146,151
CQE / CQEY	16 A	46 + ⊕	B.75,85	CX	100 A/16 A	8/0 and 6/6 + ⊕	B.156-157
CQEE	16 A	64 + ⊕	B.79	CX / CXC	80 A/16 A	4/8 + ⊕	B.161-162
CD	10 A	64 + ⊕	B.91	*can be used only in bulkhead mounting housings			
CDD	10 A	108 + ⊕	B.97				
CDSH	10 A	42 + ⊕	B.105				
180 °C Inserts size 104.27							
CNE RY**	16 A	24 + ⊕	I.8				
CX RY**	80 A/16 A	4/2 + ⊕	I.13				

** >125 °C up to 180 °C

E-Xtreme® – V-TYPE lever version

size **104.27**

Hoods – 4 pegs – without gasket

3 000 hrs resistance
 in salt-spray tests

Aggressive Environments


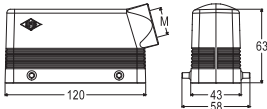

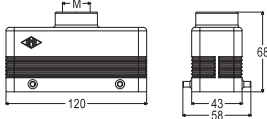

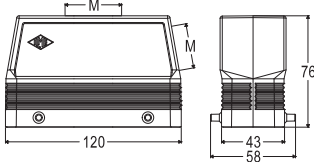

EN 60529	IP66 / IP67 / IP69
UL 50 / UL 50E	Type 12 / 4 / 4X
Ambient temperature limits	-40 °C ... +125 °C*
with silicone gasket (on request)	-60 °C ... +125 °C*
Mechanical life (cycles)	≥ 500

*(>125 °C up to 180 °C with RY inserts)

CE UK



ECBT2.E115072 | ECBT8.E115072

Item	Description	Side entry	Top entry	Entry	Dimension
	Hoods, 4 pegs, side entry	MHOE 24.25M MHOE 24.32M		M25 M32	
	Hoods, 4 pegs, top entry To be used only with a complete cable gland		MHVE 24.25M MHVE 24.32M	M25 M32	
	Hoods, 4 pegs, side or top entry, high construction To be used only with a complete cable gland	MFOE 24.32M MFOE 24.40M	MFVE 24.32M MFVE 24.40M	M32 M40	

E-Xtreme®

E

Inserts size 104.27	Poles	Pages	Inserts size 104.27	Poles	Pages	MIXO Modular Inserts	Pages
CNE	16 A	24 + ⊕ B.41	CSS	16 A	24 + ⊕	B.121	C.12-93
CCE	16 A	24 + ⊕ B.47	CMCE / CMSH	16 A	10 + 2 (aux.) + ⊕	B.146,151	C.95
CSH / JSH S	16 A	24 + ⊕ B.55,61	CX	100 A/16 A	8/0 and 6/6 + ⊕	B.156-157	
CSHT	16 A	24 + ⊕ B.68	CX / CXC	80 A/16 A	4/8 + ⊕	B.161-162	
CQE / CQEY	16 A	46 + ⊕ B.75,85					
CQEE	16 A	64 + ⊕ B.79					
CD	10 A	64 + ⊕ B.91					
CDD	10 A	108 + ⊕ B.97					
CDSH	10 A	42 + ⊕ B.105					
						180 °C Inserts size 104.27	Poles Pages
						CNE RY**	16 A 24 + ⊕ 1.8
						CX RY**	80 A/16 A 4/2 + ⊕ 1.13

** >125 °C up to 180 °C

E-Xtreme® – C-TYPE lever version

Housings, hoods and covers – 1 lever – with gasket

size **44.27**

2 000 hrs resistance
in salt-spray tests



Aggressive
Environments


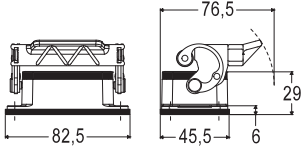

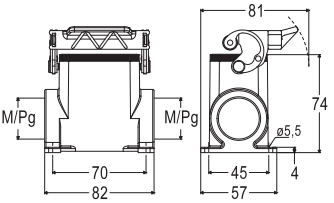

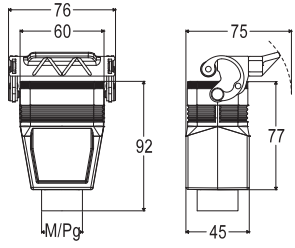


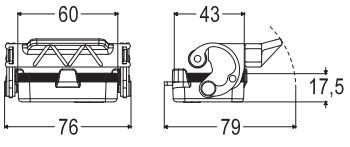


EN 60529	IP65 / IP66 / IP69
UL 50 / UL 50E	Type 12 / 4 / 4X
Ambient temperature limits	-40 °C ... +125 °C
Mechanical life (cycles)	≥ 500

CE UK




CAUS ECBT2.E115072 | ECBT8.E115072

Item	Description	Part No.	Entry	Dimension
	Bulkhead mounting housings, 1 lever and gasket	CHIE 06 L		
	Surface mounting housings, 1 lever and gasket, high construction	MAPE 06 L32	M32	
	Hoods, 1 lever and gasket, top entry, high construction, with metal adapter	MAVE 06 LG32	M32	
	Covers, 1 lever and gasket For enclosures with 2 pegs without gasket with loop for hoods 	CHCE 06 LG		

E-Xtreme®

Inserts size 44.27	Poles	Pages	MIXO Modular Inserts	Pages
CNE 16 A	6 + ⊕	B.38	MIXO modules	C.12-93
CCE 16 A	6 + ⊕	B.44	CX 02 T (2-slot sized MIXO frames)	C.95
CSH / JSH S	16 A	6 + ⊕		
CQE / CQEY	16 A	10 + ⊕		
CDD	10 A	24 + ⊕		
CDSH / CDSH NC	10 A	9 and 6 + ⊕		
CSS	16 A	6 + ⊕		
CT / CTSE*	16 A	6 + ⊕		

Accessories:



CHCP 06
Dust protection cover
Page G.46

*can be used only in bulkhead mounting housings

E-Xtreme® – C-TYPE lever version

size **44.27**


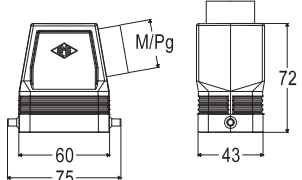

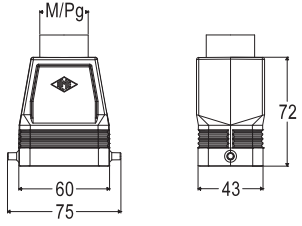



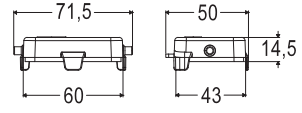
Hoods and covers – 2 pegs – without gasket

2 000 hrs resistance
in salt-spray testsAggressive
Environments

EN 60529	IP65 / IP66 / IP69
UL 50 / UL 50E	Type 12 / 4 / 4X
Ambient temperature limits	-40 °C ... +125 °C
Mechanical life (cycles)	≥ 500

CE UK

C^{AL}US ECBT2.E115072 | ECBT8.E115072

Item	Description	Side entry	Top entry	Entry	Dimension
	Hoods, 2 pegs, side entry, high construction, with metal adapter	MAOE 06 L32		M32	
	Hoods, 2 pegs, top entry, high construction, with metal adapter		MAVE 06 L32	M32	
	Covers, 2 pegs For enclosures with 1 lever and gasket with loop for hoods  or with eyelet for housings 	With loop CHCE 06 SL	With eyelet CHCE 06 L		

E-Xtreme®

E

Inserts size 44.27	Poles	Pages	MIXO Modular Inserts	Pages	
CNE	16 A	6 + ⊕	B.38	MIXO modules	C.12-93
CCE	16 A	6 + ⊕	B.44	CX 02 T (2-slot sized MIXO frames)	C.95
CSH / JSH S	16 A	6 + ⊕	B.52,58		
CQE / CQEY	16 A	10 + ⊕	B.72,82		
CDD	10 A	24 + ⊕	B.94		
CDSH / CDSH NC	10 A	9 and 6 + ⊕	B.102,108		
CSS	16 A	6 + ⊕	B.118		

Accessories:



CHCP 06
Dust protection
cover
Page G.46

E-Xtreme® – C-TYPE lever version

Housings, hoods and covers – 2 levers – with gasket

size **57.27**

2 000 hrs resistance
in salt-spray tests



Aggressive
Environments


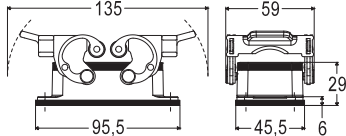

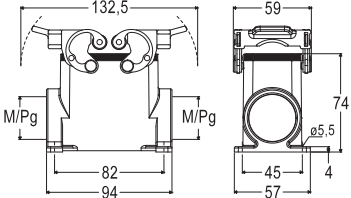

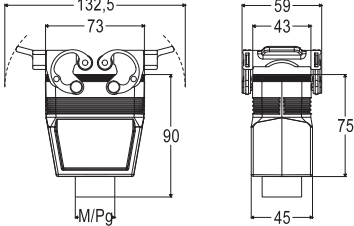
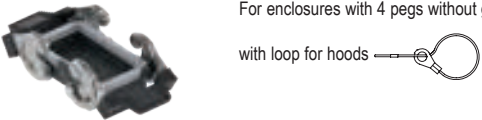
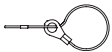
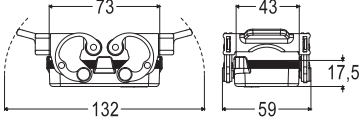


EN 60529	IP65 / IP66 / IP69
UL 50 / UL 50E	Type 12 / 4 / 4X
Ambient temperature limits	-40 °C ... +125 °C
Mechanical life (cycles)	≥ 500



CE UK
CA


ECBT2.E115072 | ECBT8.E115072

Item	Description	Part No.	Entry	Dimension
	Bulkhead mounting housings, 2 levers and gasket	CHIE 10		
	Surface mounting housings, 2 levers and gasket, high construction	MAPE 10.32	M32	
	Hoods, 2 levers and gasket, top entry, high construction, with metal adapter	MAVE 10 G32	M32	
	Covers, 2 levers and gasket For enclosures with 4 pegs without gasket with loop for hoods 	CHCE 10 G		

Inserts size 57.27	Poles	Pages	Inserts size 57.27	Poles	Pages		
CNE	16 A	10 + ☉	B.39	CT / CTSE*	16 A	10 + ☉	B.127,131
CCE	16 A	10 + ☉	B.45	CMCE / CMSH	16 A	3 + 2 (aux.) + ☉	B.144,149
CSH / JSH S	16 A	10 + ☉	B.53,59	CX	40 A/10 A	8/24 + ☉	B.170-171
CSHT	16 A	10 + ☉	B.66	*can be used only in bulkhead mounting housings			
CQE / CQEY	16 A	18 + ☉	B.73,83				
CDD	10 A	42 + ☉	B.95				
CDSH	10 A	18 + ☉	B.103				
CSS	16 A	10 + ☉	B.119				
			MIXO Modular Inserts	Pages			
			MIXO modules	C.12-93			
			CX 03 T (3-slot sized MIXO frames)	C.95			

Accessories:

 **CHCP 10**
Dust protection
cover
Page G.46

 **CR LCK**
Locking
device
Page G.43

E-Xtreme® – C-TYPE lever version

size **57.27**

Hoods and covers – 4 pegs – without gasket


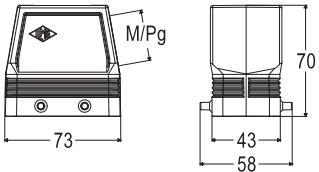

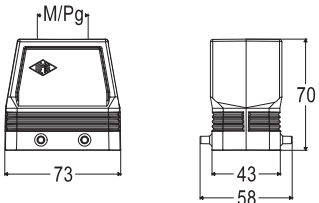

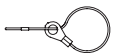
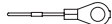
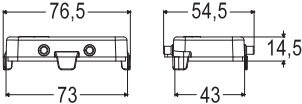
2 000 hrs resistance
 in salt-spray tests

Aggressive
Environments

CE UK
CA

EN 60529	IP65 / IP66 / IP69
UL 50 / UL 50E	Type 12 / 4 / 4X
Ambient temperature limits	-40 °C ... +125 °C
Mechanical life (cycles)	≥ 500


CAIUS ECBT2.E115072 | ECBT8.E115072

Item	Description	Side entry	Top entry	Entry	Dimension
	Hoods, 4 pegs, side entry, high construction To be used only with a complete cable gland	MFOE 10.32		M32	
	Hoods, 4 pegs, top entry, high construction To be used only with a complete cable gland		MFVE 10.32	M32	
	Covers, 4 pegs For enclosures with 2 levers and gasket with loop for hoods  or with eyelet for housings 	With loop CHCE 10 S	With eyelet CHCE 10		

E-Xtreme®

E

Inserts size 57.27	Poles	Pages	Inserts size 57.27	Poles	Pages		
CNE	16 A	10 + ⊕	B.39	CMCE / CMSH	16 A	3 + 2 (aux.) + ⊕	B.144,149
CCE	16 A	10 + ⊕	B.45	CX	40 A/10 A	8/24 + ⊕	B.170-171
CSH / JSH S	16 A	10 + ⊕	B.53,59				
CSHT	16 A	10 + ⊕	B.66				
CQE / CQEY	16 A	18 + ⊕	B.73,83				
CDD	10 A	42 + ⊕	B.95				
CDSH	10 A	18 + ⊕	B.103				
CSS	16 A	10 + ⊕	B.119				
				MIXO Modular Inserts		Pages	
				MIXO modules		C.12-93	
				CX 03 T (3-slot sized MIXO frames)		C.95	

Accessories:

CHCP 10
 Dust protection
 cover
 Page G.46

E-Xtreme® – C-TYPE lever version

Housings, hoods and covers – 2 levers – with gasket

size **77.27**

2 000 hrs resistance
in salt-spray tests




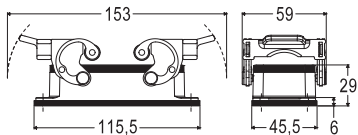

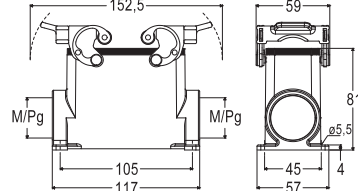

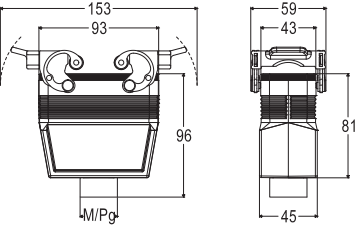

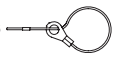
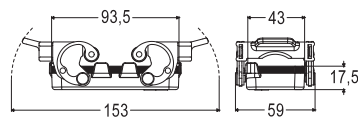
Aggressive
Environments



EN 60529	IP65 / IP66 / IP69
UL 50 / UL 50E	Type 12 / 4 / 4X
Ambient temperature limits	-40 °C ... +125 °C
Mechanical life (cycles)	≥ 500



CAIUS ECBT2.E115072 | ECBT8.E115072


Item	Description	Part No.	Entry	Dimension
	Bulkhead mounting housings, 2 levers and gasket	CHIE 16		
	Surface mounting housings, 2 levers and gasket, high construction	MAPE 16.32	M32	
	Hoods, 2 levers and gasket, top entry, high construction, with metal adapter	MAVE 16 G32	M32	
	Covers, 2 levers and gasket For enclosures with 4 pegs without gasket with loop for hoods 	CHCE 16 G		

E-Xtreme®
E


Inserts size 77.27	Poles	Pages	Inserts size 77.27	Poles	Pages	MIXO Modular Inserts	Pages
CNE	16 + ⊕	B.40	CP / CPY	35 A	6 + ⊕	MIXO modules	C.12-93
CCE	16 A	B.46	CSS	16 A	16 + ⊕	CX 04 T (4-slot sized MIXO frames)	C.95
CSH / JSH S	16 A	B.54,60	CT / CTSE*	16 A	16 + ⊕		
CSHT	16 A	B.67	CT / CTS*	10 A	40 + ⊕		
CQE / CQEY	16 A	B.74,84	CMCE / CMSH	16 A	6 + 2 (aux.) + ⊕		
CQEE	16 A	B.78	CX / CXC	80 A/16 A	4/0, 4/2 + ⊕		
CD	10 A	B.90	CX	40 A/10 A	6/12, 6/36, 9/42 and 12/2 + ⊕		
CDD	10 A	B.94					
CDSH	10 A	B.104					

*can be used only in bulkhead mounting housings

Accessories:



CHCP 16
Dust protection
cover
Page G.46



CR LCK
Locking
device
Page G.43

E-Xtreme® – C-TYPE lever version

size **77.27**

Hoods and covers – 4 pegs – without gasket


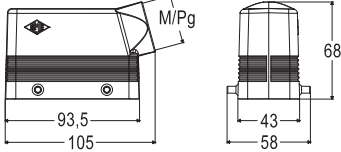

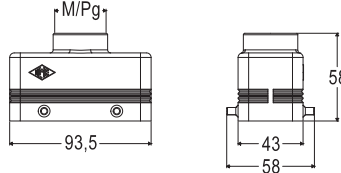

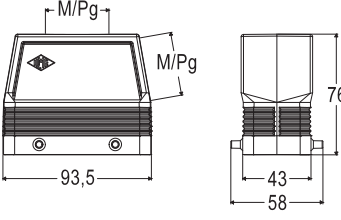

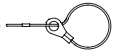
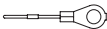
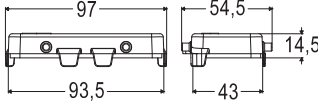
2 000 hrs resistance
in salt-spray tests

Aggressive Environments


EN 60529	IP65 / IP66 / IP69
UL 50 / UL 50E	Type 12 / 4 / 4X
Ambient temperature limits	-40 °C ... +125 °C
Mechanical life (cycles)	≥ 500

CE UK


CALUS ECBT2.E115072 | ECBT8.E115072

Item	Description	Side entry	Top entry	Entry	Dimension
	Hoods, 4 pegs, side entry, high construction	MHOE 16.25 MHOE 16.32		M25 M32	
	Hoods, 4 pegs, top entry, high construction To be used only with a complete cable gland		MHVE 16.25 MHVE 16.32	M25 M32	
	Hoods, 4 pegs, side or top entry, high construction To be used only with a complete cable gland	MFOE 16.32 MFOE 16.40	MFVE 16.32 MFVE 16.40	M32 M40	
	Covers, 4 pegs For enclosures with 2 levers and gasket with loop for hoods  or with eyelet for housings 	With loop CHCE 16 S	With eyelet CHCE 16		

E-Xtreme®

E

Inserts size 77.27	Poles	Pages	Inserts size 77.27	Poles	Pages	MIXO Modular Inserts	Pages
CNE	16 A	16 + ☉ B.40	CP / CPY	35 A	6 + ☉ B.112,114	MIXO modules	C.12-93
CCE	16 A	16 + ☉ B.46	CSS	16 A	16 + ☉ B.120	CX 04 T (4-slot sized MIXO frames)	C.95
CSH / JSH S	16 A	16 + ☉ B.54,60	CMCE / CMSH	16 A	6 + 2 (aux.) + ☉ B.145,150		
CSHT	16 A	16 + ☉ B.67	CX / CXC	80 A/16 A	4/0, 4/2 + ☉ B.158-160		
CQE / CQEY	16 A	32 + ☉ B.74,84	CX	40 A/10 A	6/12, 6/36, 9/42 and 12/2 + ☉ B.163-164, 168-169		
CQEE	16 A	40 + ☉ B.78					
CD	10 A	40 + ☉ B.90					
CDD	10 A	72 + ☉ B.94					
CDSH	10 A	27 + ☉ B.104					

Accessories:


CHCP 16
Dust protection cover
Page G.46

E-Xtreme® – C-TYPE lever version

Housings, hoods and covers – 2 levers – with gasket

size **104.27**

2 000 hrs resistance
in salt-spray tests




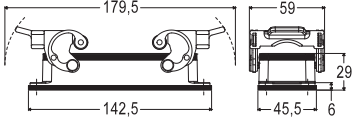

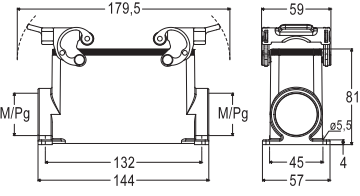

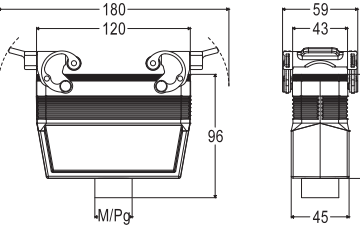

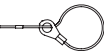
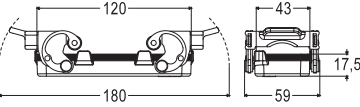
Aggressive
Environments



EN 60529	IP65 / IP66 / IP69
UL 50 / UL 50E	Type 12 / 4 / 4X
Ambient temperature limits	-40 °C ... +125 °C
Mechanical life (cycles)	≥ 500



CEC US ECBT2.E115072 | ECBT8.E115072

Item	Description	Part No.	Entry	Dimension
	Bulkhead mounting housings, 2 levers and gasket	CHIE 24		
	Surface mounting housings, 2 levers and gasket, high construction	MAPE 24.32	M32	
	Hoods, 2 levers and gasket, top entry, high construction, with metal adapter	MAVE 24 G32	M32	
	Covers, 2 levers and gasket For enclosures with 4 pegs without gasket with loop for hoods 	CHCE 24 G		

Inserts size 104.27	Poles	Pages	Inserts size 104.27	Poles	Pages	MIXO Modular Inserts	Pages
CNE	16 A	24 + ☉ B.41	CSS	16 A	24 + ☉ B.121	MIXO modules	C.12-93
CCE	16 A	24 + ☉ B.47	CT / CTSE*	16 A	24 + ☉ B.129,133	CX 06 T (6-slot sized MIXO frames)	C.95
CSH / JSH S	16 A	24 + ☉ B.55,61	CT / CTS*	10 A	64 + ☉ B.139,141		
CSHT	16 A	24 + ☉ B.68	CMCE / CMSH	16 A	10 + 2 (aux.) + ☉ B.146,151		
CQE / CQEY	16 A	46 + ☉ B.75,85	CX	100 A/16 A	8/0 and 6/6 + ☉ B.156-157		
CQEE	16 A	64 + ☉ B.79	CX / CXC	80 A/16 A	4/8 + ☉ B.161-162		
CD	10 A	64 + ☉ B.91	*can be used only in bulkhead mounting housings				
CDD	10 A	108 + ☉ B.97					
CDSH	10 A	42 + ☉ B.105					

Accessories:

CHCP 24
Dust protection
cover
Page G.46

CR LCK
Locking
device
Page G.43

E-Xtreme® – C-TYPE lever version

size **104.27**

Hoods and covers – 4 pegs – without gasket

2 000 hrs resistance
in salt-spray tests




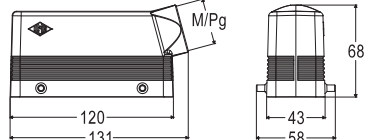

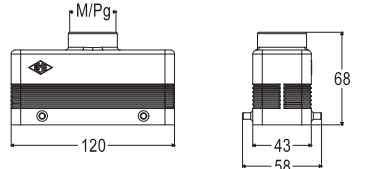

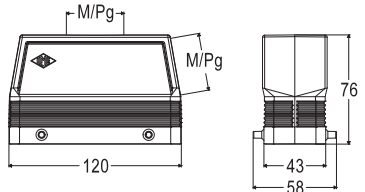



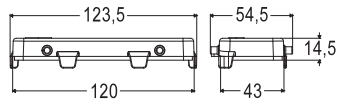
Aggressive
Environments



EN 60529	IP65 / IP66 / IP69
UL 50 / UL 50E	Type 12 / 4 / 4X
Ambient temperature limits	-40 °C ... +125 °C
Mechanical life (cycles)	≥ 500



CE UK
CEC DNV
CULUS ECBT2.E115072 | ECBT8.E115072

Item	Description	Side entry	Top entry	Entry	Dimension
	Hoods, 4 pegs, side entry, high construction	MHOE 24.25 MHOE 24.32		M25 M32	
	Hoods, 4 pegs, top entry, high construction To be used only with a complete cable gland		MHVE 24.25 MHVE 24.32	M25 M32	
	Hoods, 4 pegs, side or top entry, high construction To be used only with a complete cable gland	MFOE 24.32 MFOE 24.40	MFVE 24.32 MFVE 24.40	M32 M40	
	Covers, 4 pegs For enclosures with 2 levers and gasket with loop for hoods  or with eyelet for housings 	With loop CHCE 24 S	With eyelet CHCE 24		

E-Xtreme®

E

Inserts size 104.27	Poles	Pages	Inserts size 104.27	Poles	Pages	MIXO Modular Inserts	Pages
CNE	16 A	24 + ⊕ B.41	CSS	16 A	24 + ⊕ B.121	MIXO modules	C.12-93
CCE	16 A	24 + ⊕ B.47	CMCE / CMSH	16 A	10 + 2 (aux.) + ⊕ B.146,151	CX 06 T (6-slot sized MIXO frames)	C.95
CSH / JSH S	16 A	24 + ⊕ B.55,61	CX	100 A/16 A	8/0 and 6/6 + ⊕ B.156-157		
CSHT	16 A	24 + ⊕ B.68	CX / CXC	80 A/16 A	4/8 + ⊕ B.161-162		
CQE / CQEY	16 A	46 + ⊕ B.75,85					
CQEE	16 A	64 + ⊕ B.79					
CD	10 A	64 + ⊕ B.91					
CDD	10 A	108 + ⊕ B.97					
CDSH	10 A	42 + ⊕ B.105					

Accessories:



CHCP 24
Dust protection
cover
Page G.46

E-Xtreme® – C-TYPE lever version

Housings, hoods and covers – 2 levers – with gasket

size **77.62**

2 000 hrs resistance
in salt-spray tests




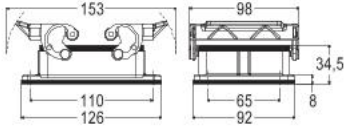

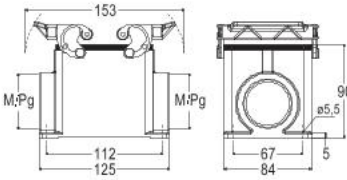

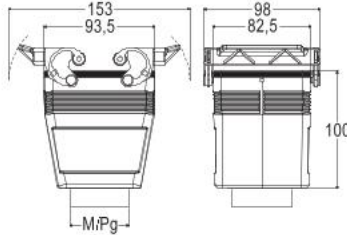


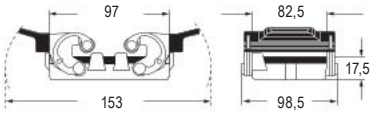
Aggressive
Environments



EN 60529	IP65 / IP66 / IP69
UL 50 / UL 50E	Type 12 / 4 / 4X
Ambient temperature limits	-40 °C ... +125 °C
Mechanical life (cycles)	≥ 500



CEC DNV VERITAS
CRAIUS ECBT2.E115072 | ECBT8.E115072

Item	Description	Part No.	Entry	Dimension
	Bulkhead mounting housings, 2 levers and gasket	CHIE 32		
	Surface mounting housings, 2 levers and gasket	MHPE 32.50	M50	
	Hoods, 2 levers and gasket, top entry, high construction, with metal adapter	MHVE 32 G40	M40	
	Covers, 2 levers and gasket For enclosures with 4 pegs without gasket with loop for hoods 	CHCE 32 G		

Inserts size (77.27) × 2	Poles	Pages	Inserts size (77.27) × 2	Poles	Pages
CNE 16 A	32 + ⊕	3.42	CSS 16 A	32 + ⊕	3.122
CCE 16 A	32 + ⊕	3.48	CTSE* 16 A	32 + ⊕	3.134
CSH / JSH S 16 A	32 + ⊕	3.56 32	CMCE / CMSH 16 A	12 + 4 (aux.) + ⊕	3.147 152
CQE / CQEY 16 A	64 + ⊕	3.76 36	*can be used only in bulkhead mounting housings		
CD 10 A	80 + ⊕	3.92	MIXO Modular Inserts		
CDD 10 A	144 + ⊕	3.98	MIXO modules		
CDSH 10 A	54 + ⊕	3.106	CX 04 T (4-slot sized MIXO frames) × 2		
CP / CPY 35 A	12 + ⊕	3.113 115			

E-Xtreme® – C-TYPE lever version

size **77.62**

Hoods and covers – 4 pegs – without gasket

2 000 hrs resistance
in salt-spray tests

Aggressive Environments


EN 60529	IP65 / IP66 / IP69
UL 50 / UL 50E	Type 12 / 4 / 4X
Ambient temperature limits	-40 °C ... +125 °C
Mechanical life (cycles)	≥ 500

CE UK



ECBT2.E115072 | ECBT8.E115072

Item	Description	Side entry	Top entry	Entry	Dimension
	Hoods, 2 pegs, without gasket, side or top entry, high construction, with metal adapter	MHOE 32.40	MHVE 32.40	M40	
	Covers, 4 pegs, without gasket For enclosures with 2 levers and gasket with loop for hoods or with eyelet for housings	With loop CHCE 32 S	With eyelet CHCE 32		

Inserts size (77.27) × 2	Poles	Pages	Inserts size (77.27) × 2	Poles	Pages		
CNE	16 A	32 + ⊕	B.42	CSS	16 A	32 + ⊕	B.122
CCE	16 A	32 + ⊕	B.48	CMCE / CMSH	16 A	12 + 4 (aux.) + ⊕	B.147,152
CSH / JSH S	16 A	32 + ⊕	B.56,62				
CQE / CQEY	16 A	64 + ⊕	B.76,86				
CD	10 A	80 + ⊕	B.92				
CDD	10 A	144 + ⊕	B.98				
CDSH	10 A	54 + ⊕	B.106				
CP / CPY	35 A	12 + ⊕	B.113,115				
				MIXO Modular Inserts		Pages	
				MIXO modules		C.12-93	
				CX 04 T (4-slot sized MIXO frames) × 2		C.95	

E-Xtreme®

Housings – 1 lever – with gasket

size **104.62**

2 000 hrs resistance
in salt-spray tests



Aggressive
Environments


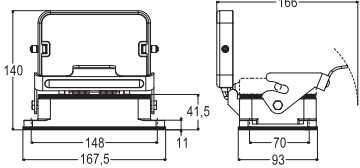

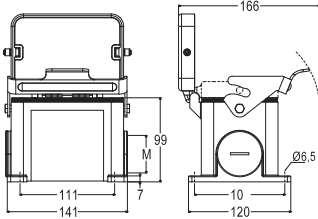


EN 60529	IP65 / IP66 / IP69
UL 50 / UL 50E	Type 12 / 4 / 4X
Ambient temperature limits	-40 °C ... +125 °C
Mechanical life (cycles)	≥ 500

CE UK
CA



CAUS® ECBT2.E115072 | ECBT8.E115072


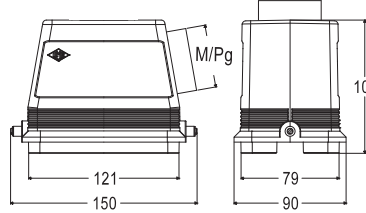

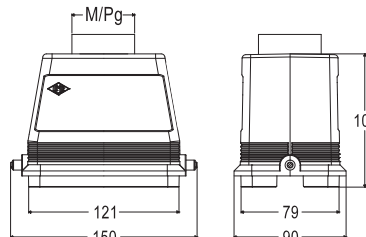

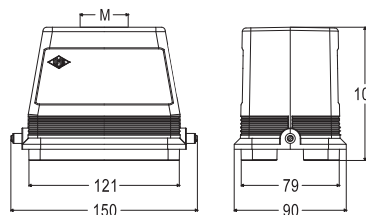
Item	Description	Part No.	Entry	Dimension
	Bulkhead mounting housings, 1 lever and gasket, with metal cover	CHIE 48 LS		
	Surface mounting housings, 1 lever and gasket, with metal cover	MHPE 48 LS40	M40 × 2	

Inserts size (104.27) × 2	Poles	Pages	Inserts size (104.27) × 2	Poles	Pages
CNE 16 A	48 + ⊕	B.43	CTSE* 16 A	48 + ⊕	B.135
CCE 16 A	48 + ⊕	B.49	CMCE / CMSH 16 A	10 + 2 (aux.) + ⊕	B.148,153
CSH / JSH S 16 A	48 + ⊕	B.57,63	*can be used only in bulkhead mounting housings		
CQE / CQEY 16 A	92 + ⊕	B.77,87			
CD 10 A	128 + ⊕	B.93			
CDD 10 A	216 + ⊕	B.99			
CDSH 10 A	84 + ⊕	B.107			
CSS 16 A	48 + ⊕	B.123			
			MIXO Modular Inserts		Pages
			MIXO modules		C.12-93
			CX 06 T (6-slot sized MIXO frames) × 2		C.95

E-Xtreme®**Hoods - 2 pegs - without gasket**size **104.62****2 000 hrs resistance**
in salt-spray tests**Aggressive**
Environments

EN 60529	IP65 / IP66 / IP69
UL 50 / UL 50E	Type 12 / 4 / 4X
Ambient temperature limits	-40 °C ... +125 °C
Mechanical life (cycles)	≥ 500

CE UK
CAC^{RU}US ECBT2.E115072 | ECBT8.E115072

Item	Description	Side entry	Top entry	Entry	Dimension
	Hoods, 2 pegs, without gasket, side entry, with metal adapter	MHOE 48 L40		M40	
	Hoods, 2 pegs, without gasket, top entry, with metal adapter		MHVE 48 L40	M40	
	Hoods, 2 pegs, without gasket, top entry		MFVE 48 L63	M63	

Inserts size (104.27) × 2	Poles	Pages	Inserts size (104.27) × 2	Poles	Pages
CNE 16 A	48 + ⊕	B.43	CMCE / CMSH 16 A	10 + 2 (aux.) + ⊕	B.148,153
CCE 16 A	48 + ⊕	B.49			
CSH / JSH S	48 + ⊕	B.57,63			
CQE / CQEY	92 + ⊕	B.77,87			
CD 10 A	128 + ⊕	B.93			
CDD 10 A	216 + ⊕	B.99			
CDSH 10 A	84 + ⊕	B.107			
CSS 16 A	48 + ⊕	B.123			
			MIXO Modular Inserts		Pages
			MIXO modules		C.12-93
			CX 06 T (6-slot sized MIXO frames) × 2		C.95

E-Xtreme® – IP68 high protection version

size **44.27**

Housings, hoods and covers – Screw locking

3 000 hrs resistance
in salt-spray tests



Aggressive
Environments


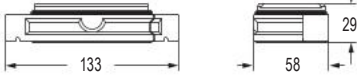

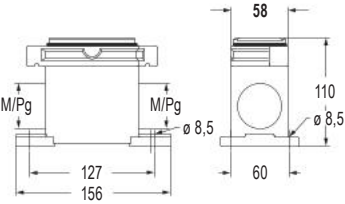

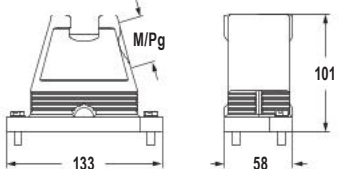

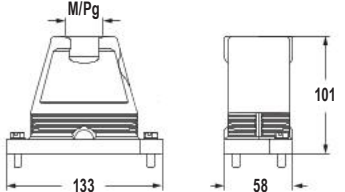





EN 60529	IP66 / IP68 / IP69
UL 50 / UL 50E	Type 12 / 4 / 4X
Ambient temperature limits with silicone gasket (on request)	-40 °C ... +125 °C
Mechanical life (cycles)	-60 °C ... +125 °C* ≥ 500

*(>125 °C up to 180 °C with RY inserts)



CAIUS ECBT2.E115072 | ECBT8.E115072

Item	Description	Part No.	Entry	Dimension
	Bulkhead mounting housings, screw locking Optional mounting frame CG .. FL is available to ensure water tightness for bulkhead mounting housing when fitted onto a cabinet panel. (See page 6.44)	CGIE 06		
	Surface mounting housings, screw locking	MGPE 06.32	M32	
	Hoods, side entry, screw locking	MGOE 06.25 MGOE 06.32	M25 M32	
	Hoods, top entry, screw locking	MGVE 06.25 MGVE 06.32 MGVE 06.40	M25 M32 M40	
	Covers, screw locking, for housings With loop 	CGCE 06		

Inserts size 44.27	Poles	Pages
CNE 16 A	6 + ⊕	3.38
CCE 16 A	6 + ⊕	3.44
CSH / JSH S	6 + ⊕	3.52 36
CQE / CQEY	16 A	3.72 32
CDD 10 A	24 + ⊕	3.94
CDSH / CDSH NC	10 A	3.102 108
CSS 16 A	6 + ⊕	3.116
CT / CTSE*	16 A	3.126 130

MIXO Modular Inserts	Pages
MIXO modules	3.12-93
CX 02 T (2-slot sized MIXO frames)	3.95

180 °C Inserts size 44.27	Poles	Pages
CNE RY**	16 A 6 + ⊕	3.1

** >125 °C up to 180 °C

Accessories:

 **CGCP FX**
Dust protection
cover
Page [6.47](#)

 **CGCP MB**
Dust protection
cover
Page [6.47](#)

*can be used only in bulkhead mounting housings

E-Xtreme® – IP68 high protection version

size **57.27**

Housings, hoods and covers – Screw locking

3 000 hrs resistance
in salt-spray tests


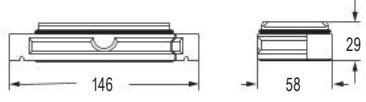

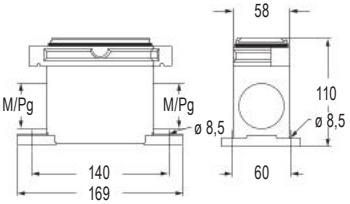

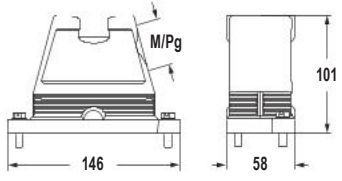

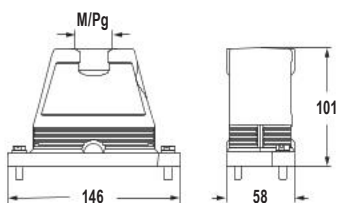



Aggressive Environments


EN 60529	IP66 / IP68 / IP69
UL 50 / UL 50E	Type 12 / 4 / 4X
Ambient temperature limits	-40 °C ... +125 °C
with silicone gasket (on request)	-60 °C ... +125 °C*
Mechanical life (cycles)	≥ 500

*(>125 °C up to 180 °C with RY inserts)



ECBT2.E115072 | ECBT8.E115072

Item	Description	Part No.	Entry	Dimension
	Bulkhead mounting housings, screw locking Optional mounting frame CG .. FL is available to ensure water tightness for bulkhead mounting housing when fitted onto a cabinet panel. (See page E.43)	CGIE 10		
	Surface mounting housings, screw locking	MGPE 10.32	M32	
	Hoods, side entry, screw locking	MGOE 10.25 MGOE 10.32	M25 M32	
	Hoods, top entry, screw locking	MGVE 10.25 MGVE 10.32 MGVE 10.40	M25 M32 M40	
	Covers, screw locking, for housings With loop 	CGCE 10		

Inserts size 57.27	Poles	Pages	Inserts size 57.27	Poles	Pages	180 °C Inserts size 57.27	Poles	Pages	
CNE	16 A	10 + ⊕	CT / CTSE*	16 A	10 + ⊕	CNE RY**	16 A	10 + ⊕	
CCE	16 A	10 + ⊕	CMCE / CMSH	16 A	3 + 2 (aux.) + ⊕				
CSH / JSH S	16 A	10 + ⊕	CX	40 A/10 A	8/24 + ⊕	** >125 °C up to 180 °C			
CSHT	16 A	10 + ⊕	*can be used only in bulkhead mounting housings						
CQE / CQEY	16 A	18 + ⊕	Accessories:						
CDD	10 A	42 + ⊕	MIXO Modular Inserts			CGCP FX	CGCP MB		
CDSH	10 A	18 + ⊕	MIXO modules			Dust protection cover	Dust protection cover		
CSS	16 A	10 + ⊕	CX 03 T (3-slot sized MIXO frames)			Page E.47	Page E.47		

E-Xtreme® – IP68 high protection version

size **77.27**

Housings, hoods and covers – Screw locking

3 000 hrs resistance
in salt-spray tests



Aggressive
Environments


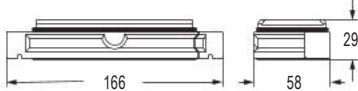

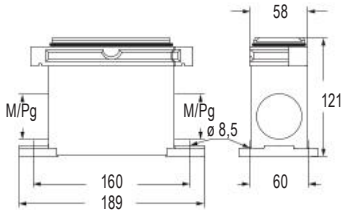

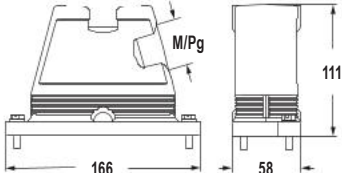

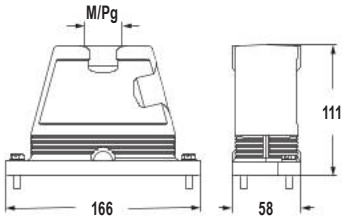


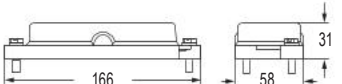


EN 60529	IP66 / IP68 / IP69
UL 50 / UL 50E	Type 12 / 4 / 4X
Ambient temperature limits with silicone gasket (on request)	-40 °C ... +125 °C
Mechanical life (cycles)	-60 °C ... +125 °C* ≥ 500

*(>125 °C up to 180 °C with RY inserts)



CAIUS ECBT2.E115072 | ECBT8.E115072

Item	Description	Part No.	Entry	Dimension
	Bulkhead mounting housings, screw locking Optional mounting frame CG .. FL is available to ensure water tightness for bulkhead mounting housing when fitted onto a cabinet panel. (See page E.43)	CGIE 16		
	Surface mounting housings, screw locking	MGPE 16.40	M40	
	Hoods, side entry, screw locking	MGOE 16.32 MGOE 16.40 MGOE 16.50	M32 M40 M50	
	Hoods, top entry, screw locking	MGVE 16.25 MGVE 16.225 MGVE 16.32 MGVE 16.40 MGVE 16.50	M25 M25 × 2 M32 M40 M50	
	Covers, screw locking, for housings With loop 	CGCE 16		

Inserts size 77.27	Poles	Pages	Inserts size 77.27	Poles	Pages	MIXO Modular Inserts	Pages
CNE	16 A	16 + ⊕	CSS	16 A	16 + ⊕	MIXO modules	E.12-93
CCE	16 A	16 + ⊕	CT / CTSE*	16 A	16 + ⊕	CX 04 T (4-slot sized MIXO frames)	E.93
CSH / JSH S	16 A	16 + ⊕	CT / CTS*	10 A	40 + ⊕		
CSHT	16 A	16 + ⊕	CMCE / CMSH	16 A	6 + 2 (aux.) + ⊕		
CQE / CQEY	16 A	32 + ⊕	CX / CXC	80 A/16 A	4/0, 4/2 + ⊕		
CQEE	16 A	40 + ⊕	CX	40 A/10 A	6/12, 6/36, 9/42 and 12/2 + ⊕		
CD	10 A	40 + ⊕					
CDD	10 A	72 + ⊕					
CDSH	10 A	27 + ⊕					
CP / CPY	35 A	6 + ⊕					

*can be used only in bulkhead mounting housings

Accessories: see page [E.197](#)

180 °C Inserts size 77.27	Poles	Pages
CNE RY**	16 A	16 + ⊕
CP RY**	35 A	6 + ⊕
CX RY**	80 A	4 + ⊕
CX RY**	80 A/16 A	4/2 + ⊕

** >125 °C up to 180 °C

E-Xtreme® – IP68 high protection version

size **104.27**

Housings, hoods and covers – Screw locking

3 000 hrs resistance
in salt-spray testsAggressive
Environments

EN 60529	IP66 / IP68 / IP69
UL 50 / UL 50E	Type 12 / 4 / 4X
Ambient temperature limits	-40 °C ... +125 °C
with silicone gasket (on request)	-60 °C ... +125 °C*
Mechanical life (cycles)	≥ 500


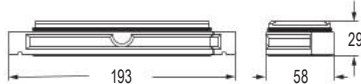

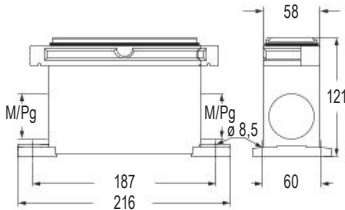

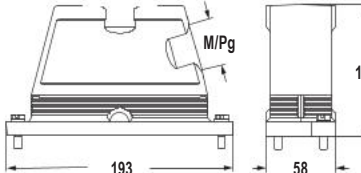

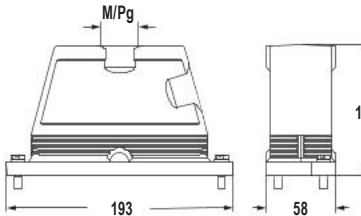


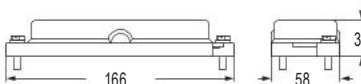
*(>125 °C up to 180 °C with RY inserts)

CE UK



C A U S

ECBT2.E115072 | ECBT8.E115072

Item	Description	Part No.	Entry	Dimension
	Bulkhead mounting housings, screw locking Optional mounting frame CG .. FL is available to ensure water tightness for bulkhead mounting housing when fitted onto a cabinet panel. (See page E.43)	CGIE 24		
	Surface mounting housings, screw locking	MGPE 24.40 MGPE 24.240	M40 M40 × 2	
	Hoods, side entry, screw locking	MGOE 24.32 MGOE 24.40 MGOE 24.50	M32 M40 M50	
	Hoods, top entry, screw locking	MGVE 24.325 MGVE 24.32 MGVE 24.232 MGVE 24.40 MGVE 24.240 MGVE 24.50	M25 × 3 M32 M32 × 2 M40 M40 × 2 M50	
	Covers, screw locking, for housings With loop 	CGCE 24		

Inserts size 104.27	Poles	Pages	Inserts size 104.27	Poles	Pages	180 °C Inserts size 104.27	Poles	Pages
CNE	16 A	24 + ☉ E.41	CT / CTSE*	16 A	24 + ☉ E.129 E.133	CNE RY**	16 A	24 + ☉ E.8
CCE	16 A	24 + ☉ E.47	CT / CTS*	10 A	64 + ☉ E.139 E.141	CX RY**	80 A/16 A	4/2 + ☉ E.13
CSH / JSH S	16 A	24 + ☉ E.55 E.51	CMCE / CMSH	16 A	10 + 2 (aux.) + ☉ E.146 E.151	** >125 °C up to 180 °C		
CSHT	16 A	24 + ☉ E.66	CX	100 A/16 A	8/0 and 6/6 + ☉ E.156 E.157			
CQE / CQEY	16 A	46 + ☉ E.75 E.85	CX / CXC	80 A/16 A	4/8 + ☉ E.161 E.162			
CQEE	16 A	64 + ☉ E.79	*can be used only in bulkhead mounting housings					
CD	10 A	64 + ☉ E.91						
CDD	10 A	108 + ☉ E.97						
CDSH	10 A	42 + ☉ E.105						
CSS	16 A	24 + ☉ E.121						
			MIXO Modular Inserts			Pages		
			MIXO modules			E.12-93		
			CX 06 T (6-slot sized MIXO frames)			E.95		

Accessories:

CGCP FX
Dust protection cover
Page [E.47](#)

CGCP MB
Dust protection cover
Page [E.47](#)

Panel cut-out drawings

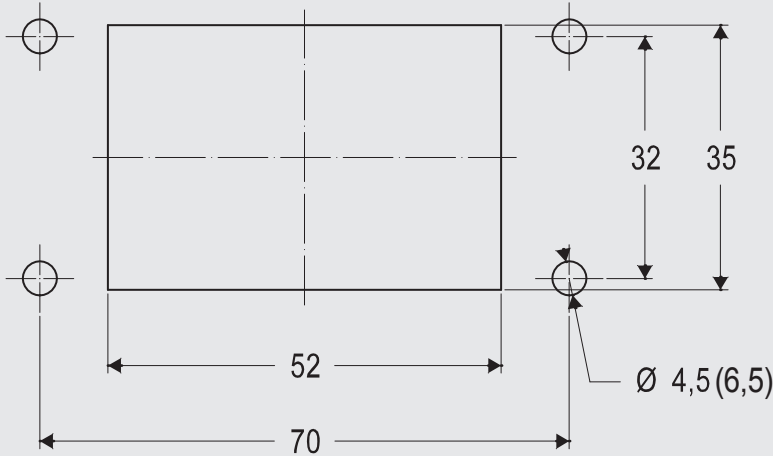
For E-Xtreme® series bulkhead mounting housings

To guarantee the declared IP degree of protection of the housings reported in this catalogue, according to EN IEC 60529 or to the relevant Type rating per ANSI/UL 50 and 50E (for those products bearing approval to those ratings), the surface of the mounting panel must meet the following requirements (definitions are provided in ISO 4287 standard):

Waviness $Wt \leq 0,2$ mm over a distance of 200 mm (measured on the panel without load)
Roughness $Ra \leq 16$ μ m

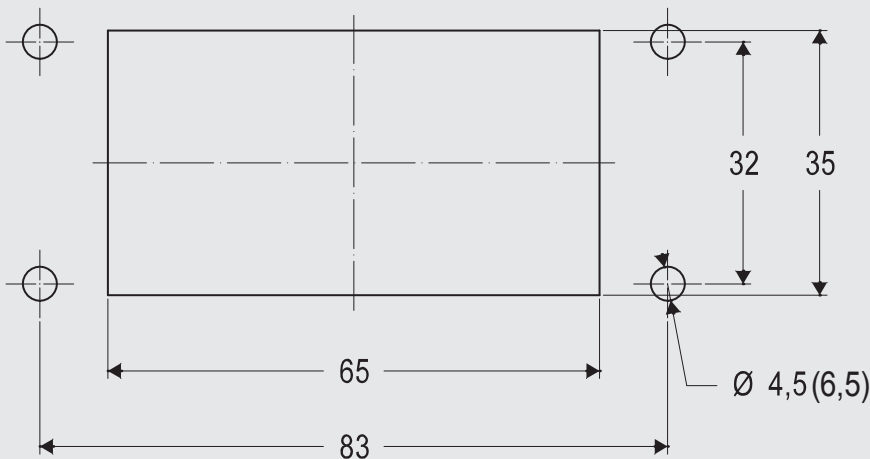
Scale 1:1

Size 44.27



Required screws: 4
Screws size: M4 (M6 for IP68 version)
Recommended torque:
 0,8 – 1,2 Nm / 7.1 – 10.6 lb.in

Size 57.27



Required screws: 4
Screws size: M4 (M6 for IP68 version)
Recommended torque:
 0,8 – 1,2 Nm / 7.1 – 10.6 lb.in

Notes: The values of tightening torque indicated above are just recommended values, that must be related – by the designer of the final application – to the resistance class of the screws (not included), with the assumption that the mounting panel is sufficiently rigid (stiff). If the deflection of the panel, under the effect of tightening the screws, is greater than 0,7 mm over a distance of 100 mm, it is necessary to use the counter-flanges mentioned in our catalogue or the special flange gaskets available upon request (please contact our Sales Department). For the CGI/MGI IP68 enclosures the specific counter-flanges mentioned in the catalogue are always recommended.

Accessories:



CG .. FL
Counterflanges for IP68
bulkhead mounting housings
 Page G.45

Panel cut-out drawings

For E-Xtreme® series bulkhead mounting housings

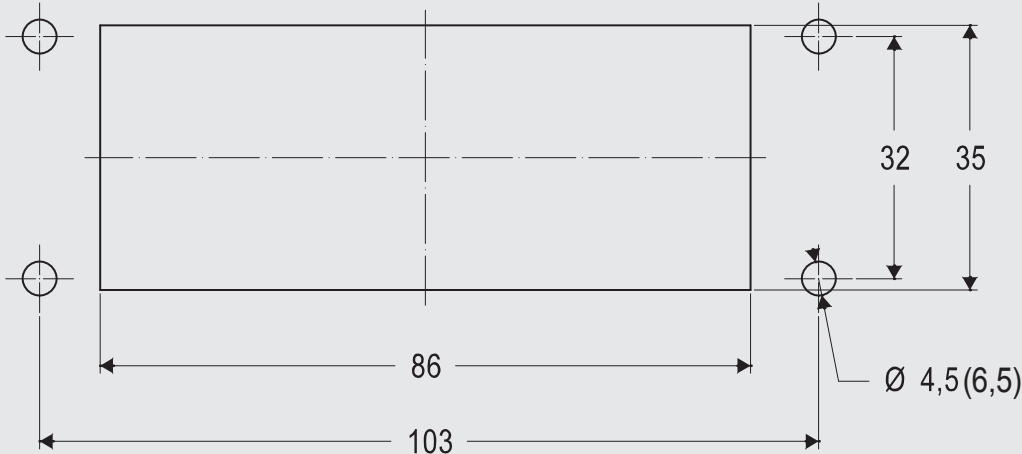
To guarantee the declared IP degree of protection of the housings reported in this catalogue, according to EN IEC 60529 or to the relevant Type rating per ANSI/UL 50 and 50E (for those products bearing approval to those ratings), the surface of the mounting panel must meet the following requirements (definitions are provided in ISO 4287 standard):

Waviness $Wt \leq 0,2$ mm over a distance of 200 mm
(measured on the panel without load)

Roughness $Ra \leq 16$ μ m

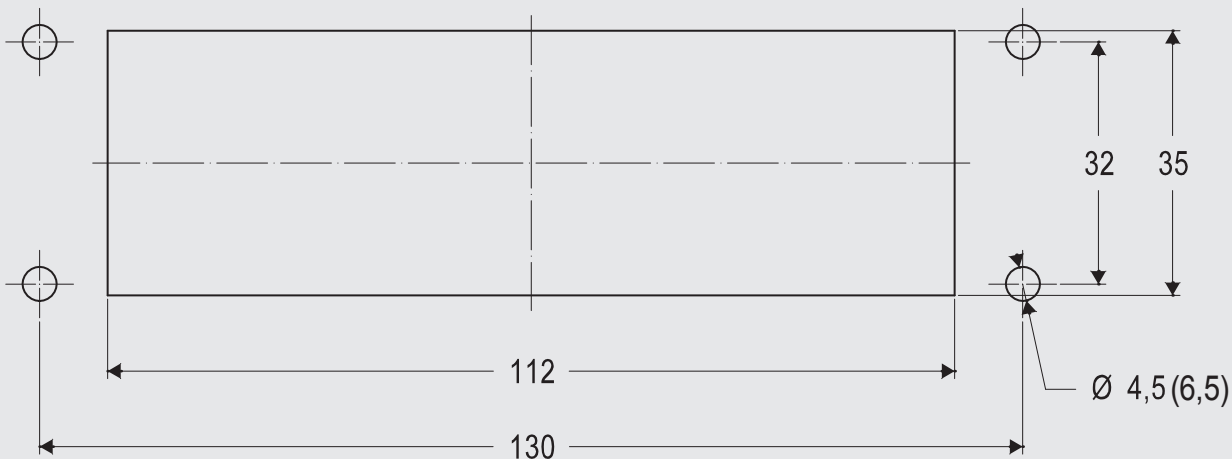
Scale 1:1

Size 77.27



Required screws: 4
Screws size: M4 (M6 for IP68 version)
Recommended torque:
 0,8 – 1,2 Nm / 7.1 – 10.6 lb.in

Size 104.27



Required screws: 4
Screws size: M4 (M6 for IP68 version)
Recommended torque:
 0,8 – 1,2 Nm / 7.1 – 10.6 lb.in

Notes: The values of tightening torque indicated above are just recommended values, that must be related – by the designer of the final application – to the resistance class of the screws (not included), with the assumption that the mounting panel is sufficiently rigid (stiff). If the deflection of the panel, under the effect of tightening the screws, is greater than 0,7 mm over a distance of 100 mm, it is necessary to use the counter-flanges mentioned in our catalogue or the special flange gaskets available upon request (please contact our Sales Department). For the CGI/MGI IP68 enclosures the specific counter-flanges mentioned in the catalogue are always recommended.

Accessories:



CG .. FL
Counterflanges for IP68
bulkhead mounting housings
 Page G.45



EMC enclosures in standard size



EMC connector enclosures and accessories

The EMC series of connector enclosures and accessories has been designed for use in electrical/electronic equipment for machines. Available as bulkhead mounting housings and hood versions in various sizes 44.27, 57.27, 77.27 and

104.27, they not only maintain the robustness and reliability of standard types but also offer increased high-frequency shielding characteristics, setting them apart from other options in the market.

SUM-UP

- > Aluminium die-cast housings available in bulkhead-mounted, surface-mounted versions.
- > Aluminium die-cast hoods with metric cable entries up to M40.
- > IL-BRID locking device in self-extinguishing thermoplastic material and stainless steel core or C-TYPE stainless steel locking levers.
- > EMI/RFI Rubber – Conductive material flange and top gasket.

Markings and Approvals

- CE and UKA markings, EAC not applicable
- UL certified for USA and Canada for Type 12, and 4 degrees of protection (enclosure type ratings, equivalent to NEMA rating)
- IP65 / IP66 / IP69 degree of protection
- RoHS: compliant



Watch our clip

FOCUS

EMC technology

The significant increase in shielding attenuation of the EMC enclosures is primarily achieved by providing a homogeneous and as uniform as possible electrical continuity of earthing to the cable shield in the connection between cable and hood and between hood and housing.

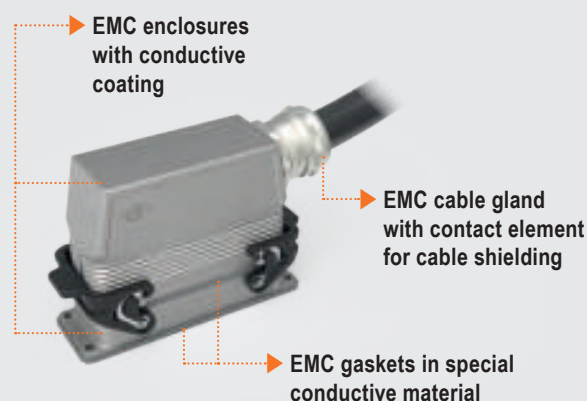
Special conductive gaskets have replaced standard thermoplastic rubber gaskets while the enclosure surfaces are treated to make them highly conductive while maintaining corrosion resistance. For best results, the surface underneath the gasket should be conductive, and EMC cable glands should be used.

The shielding capability of a connector is achieved primarily by providing a homogeneous and uniform electrical continuity between the enclosure components (hood and housing), cable shield and device body.

ILME bulkhead-mounted and surface-mounted housings are supplied with conductive gaskets, guaranteeing optimal shielding and sealing performance.

IMPORTANT NOTE:

For optimal shielding performance of the connectors, it is essential to improve the quality of the cables (which are mainly responsible for radiated interference) and use EMC cable glands, which dramatically increase the efficiency of shielding by creating a very homogeneous and continuous contact between the cable shield and connector enclosure.





EMC

Directives and standards

The concept of **Electromagnetic Compatibility (EMC)** is the reversal in the positive sense of what was until recently known as **Electromagnetic Interference (EMI)**: **we have electromagnetic compatibility** between a device and the environment (including surrounding equipment) when there is no reciprocal electromagnetic interference or when this is within tolerable limits.

In other words, **to obtain electromagnetic compatibility**, measures must be adopted aimed at bringing the electrical or electronic equipment to levels of **emission** and **electromagnetic immunity** against electromagnetic interference such that it continues to function properly without causing disturbance to other equipment present in the surrounding environment.

In the electrical equipment of industrial machines, rectangular multipole connectors with their metallic enclosures are widely used due to their high standards of safety, reliability, mechanical robustness and resistance to corrosion and pollution.

These connectors are passive electromechanical components: they do not generate electromagnetic interference and are not disturbed in their function. Taken by themselves, therefore, they fall outside the scope of Directive 2014/30/EU on electromagnetic compatibility and the CE marking is therefore not required for EMC aspects: it still applies, however, under the Low Voltage Directive 2014/35/EU.

It is rather the devices and industrial equipment mentioned above, in which the connectors are for the most part used (e.g. on-board electric panels) which, taken as a whole, must be CE marked also for EMC aspects, having to meet the essential requirements of the EMC Directive.

For the EMC in **industrial environments** two European standards are in force, not intended for specific equipment, which regulate the **emissions** and **immunity** of devices.

These are therefore generic standards, one for **emissions EN 61000-6-4:2007 + A1:2011** (class. CEI 210-66:2007 + 210-66;V1:2011, equivalent to IEC 61000-4:2006 + A1:2010) and one for **immunity EN 61000-6-2:2005** (class. CEI 210-54:2006, equivalent to IEC 61000-6-2:2005) ¹⁾.

These apply in the absence of provisions in the particular EMC product standards or in the total absence of the latter.

For industrial equipment, when appliances are not intentionally designed to generate radio frequencies ²⁾, the latter case applies (no particular standards). In the European standards for switchgear and controlgear (EN 60947-1) and in those for the electrical equipment of machines

EN 60204-1 emission and immunity limits have been for some time in the process of being issued, as well as their verification, if necessary, with reference to above mentioned EMC standards for industrial environment.

EMC testing should not be performed on individual components, but rather on the entire apparatus, sometimes not without inconsiderable logistical difficulties, due to their size, reproducing as far as possible their operation in real operating conditions.

It is therefore incorrect to assign limits of electromagnetic emission and immunity imposed on the equipment on, for example, electrical connectors used as components of the equipment.

¹⁾ There are two similar standards for the other standardized environment, defined as **residential, commercial and light industrial environment**, respectively **EN 61000-6-3:2007 + A1:2011** (class. CEI 210-65:2007 + CEI 210-61;V1:2011) for emissions (equivalent to IEC 61000-6-3:2006 + A1:2010) and **EN 61000-6-1:2007** (class. CEI 210-64:2007) for immunity (equivalent to IEC 61000-6-1:2006).

²⁾ In which case for such devices, called **ISM (industrial, scientific, medical)** the **-EN 55011:2007** standard for emission of radio interference would apply.

Electromagnetic interference and ILME connectors

Many years ago the entry into force of the first EMC European Directive, with requirement for electrical and electronic equipment to comply with the levels of electromagnetic pollution dictated by the standards, brought renewed interest in all the appropriate steps to mitigate the effects of electromagnetic interference.

Electromagnetic interference can occur in two forms: **conducted or radiated**. With reference to connectors, **conducted interference** transmitted on conductors wired to the connectors, is, for example: harmonics, superimposed on the voltage of the power supply at 50 Hz, caused by withdrawal of biased current or by electromechanical or electronic switches, or radio frequency interference noise which is inductively or capacitively coupled with the cable, overlapping transported signals.

This is characterized by frequency and amplitude (intensity) and can be filtered to some extent, in both in the outgoing (emission) and incoming (immunity) directions, only via in-line passive electrical filters, which the designer of the electrical equipment must foresee since he is the only one with a knowledge of all the terms of the problem ³⁾.

Radiated interference, transmitted in the form of electromagnetic waves, is characterized by the values of amplitude of associated electric (V/m) and magnetic fields and with the frequency or frequency band (rarely is this located on a single frequency, more often it occupies a band). This may come from inside the device: in this case it is necessary to mitigate emissions. Or from the outside, in which case it is necessary to raise immunity.

By test convention, **interference with frequency up to 30 MHz** is considered to be conducted and **irradiated with frequency above 30 MHz up to 1 GHz**.

The sources of electromagnetic interference are classified as **intentional** and **unintentional**.

The first (e.g. radio-telecommunication antennas, mobile phones) use high frequency electromagnetic fields for functional reasons. For the second (e.g. ignition of internal combustion engines, electric arc furnaces) they are a by-product.

In most industrial applications, compared to the overall EMC issues of a device, connectors (inserts + enclosures), taken by themselves, are not the priority concern of the designer.

The enclosures of the low-frequency industrial connectors, taking shape as a barrier to a "shell", are implicitly a "peripheral" aspect: the designer of electrical equipment / electronics will take care first of all the "core" of the EMC problem, that of the active components inside of their systems, by limiting the emissions and enhance immunity.

In fact, to have significant problems due to radiation through the opening constituted by a connector enclosure on a control panel, there must be a particularly "efficient" radiofrequency source inside the panel.

Essentially, significant design errors must have been committed regarding the EMC of the entire equipment.

In certain cases the coupling of connectors may constitute the weak link in the chain, for example where it is not possible for functional reasons to further reduce interference of the electronics inside the control panel. In these cases one must rely on the efficiency of the shield. Even if the equipment manufacturer uses shielded fabrication and high quality shielded cables, continuity and homogeneity of such shielding could be significantly degraded precisely in the passage between free connector and panel.

In dealing with electromagnetic compatibility of electrical equipment of an industrial machine, a second aspect to be addressed as a priority is the presence of large quantities of interface cabling.

In these cases, the significant attenuation of the shield necessary for the cables must not be jeopardised by the connector enclosures due to imperfect earthing of the cable shield.

It should nevertheless be pointed out that increasing shielding may not be sufficient to solve possible problems and should be considered as a complementary choice.

³⁾ For example, for trapezoidal D-Sub type connectors for digital data transmission, there are connectors on the market which incorporate "general purpose" filters for any conducted interference.

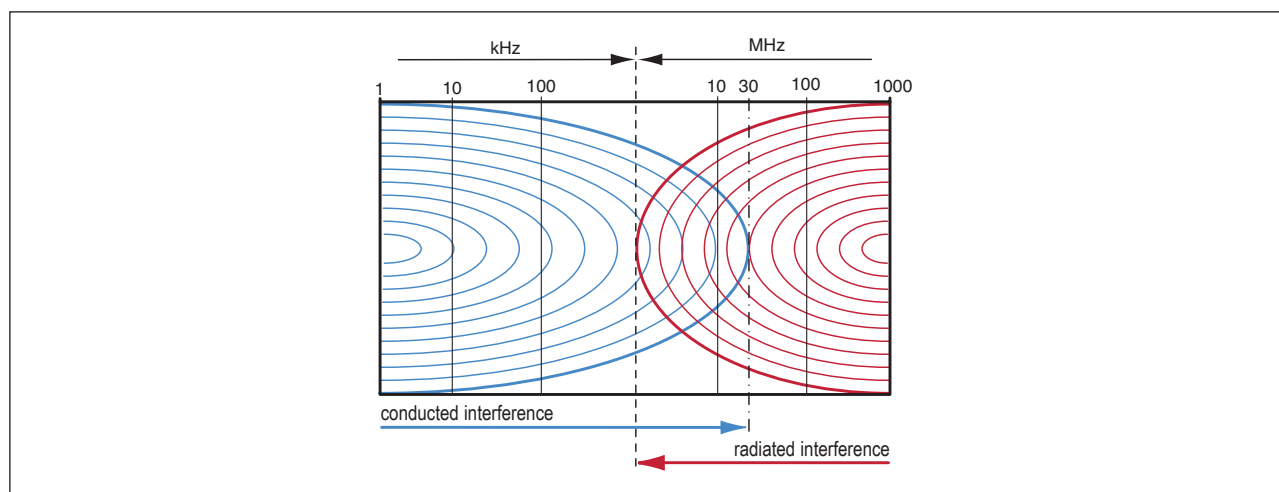


Figure 1



Electromagnetic shielding of connectors: fundamental principles

To consider the electromagnetic compatibility aspects of an electrical/electronic device in the final verification rather than in the design phase almost always leads to a substantial increase in overall development time and costs.

The designer who deals with electromagnetic compatibility issues should use the same rules and the same precautions regardless of whether the equipment is subsequently shielded.

Numerous products meet electromagnetic compatibility standards without the use of shielding. However, when all other limiting interventions are impossible or uneconomical, recourse to increased efficiency of the electromagnetic shield is the only answer.

An **electromagnetic shield** is a barrier to the transmission of electromagnetic fields.

To generalise the concept to include conducted emissions, a filter can be considered as a shield. We will restrict ourselves here to considering a shield as a barrier to radiated emissions.

The metallic containers which completely enclose an electrical/electronic device or a part thereof **constitute an electromagnetic shield**, with the task of preventing the emissions of electrical/electronic devices or a part thereof to radiate outside the equipment container itself.

A cable connected to a device is part of the same for the purposes of electromagnetic compatibility.

A flexible multicore cable is shielded by surrounding the insulated conductors with a conductive metal mesh.

An electromagnetic shield is characterized by a parameter which measures its efficiency.

The shielding attenuation is the ratio between the radiated power generated inside a device and the residual radiated power outside the unit. The attenuation introduced by a shield can be measured by comparing the absence and presence of the shield.

Shielding attenuation is measured in dB (decibel). 20 dB is equivalent to an order of magnitude, i.e. attenuation of a factor of 10, 40 dB = attenuation of a factor of 100, etc.

To obtain large shielding attenuation values (e.g. 100 dB) the shield must completely enclose the electronic device and not have any means of access from the outside, such as openings, joints, cracks or cables. Any means of access through a shield, if not properly treated, can drastically reduce the efficiency of the shield.

The passage of a cable through a shield must be properly considered. One common method is to place filters on the cable at which it crosses the shield. Another is to use shielded cables, with their shields connected for the entire perimeter to the equipment shield.

To reduce radiated emissions of a cable, the cable shield must be connected to a point with zero potential (an ideal ground therefore, not the "signal" ground of an electronic circuit). To achieve electromagnetic shielding conductive materials (metals) are used.

Shielding attenuation depends mainly on the electrical conductivity of the material and the thickness of the shield.

Rectangular or square connectors – special case – intrinsically anisotropic, are more difficult to shield and less predictable in behaviour than circular connectors (isotropic geometry) used, not by accident, with coaxial terminations for RF applications.

Connector enclosures are typically made of aluminium die cast alloy, an excellent metal for shielding electric fields because it is an excellent conductor. It is also better than steel in shielding phenomena of an impulsive nature (typical example is electrostatic discharge) which cause interference in the high frequency spectrum and is among the most insidious and dangerous.

It is important to ensure electrical continuity along the boundary of the enclosure, not only to ensure high shielding attenuation but also to avoid accumulation of static electricity.

It is important not to "economically" tip the balance of a screening system which is only as effective as its weakest component.

A good shielded cable has a shield attenuation greater than that attributable to the connector, but only for very small lengths of cable (e.g. one metre). When the length of the shielded cable increases, shield attenuation is significantly reduced.

This indicates that it is much more important to improve the shield quality of cables, which are mainly responsible for radiated interference emissions and in an electrical system are often present in considerable quantity, before that of the connector.

What dramatically increases the efficiency of shielding is the quality of its connection to the conductor: EMC cable glands create a very homogeneous and continuous contact between the cable shield and connector enclosure.

Experimental tests

Tests for measurement of the shielding of ILME special EMC enclosures for multipole rectangular connectors for industrial use were conducted at the CESI EMC Laboratory in Milan, national notified body for certification under the EMC Directive.

Shielding attenuation of a component is defined as the ratio of the power radiated within the component and the maximum interference power outside the component in the room (**VG 95214-11**).

For a connector it can be expressed, in analogy with cables, as a function of transfer impedance, which is the ratio between the voltage induced in the shield and the current flowing outside the same. The transfer impedance measurement is a widely used and accepted method to determine shielding attenuation of coaxial cables and connectors.

Only recently, due to the increase in digital data transmission speeds and the increase in frequencies of transmitted signals, the issue of identifying efficient and repeatable methods for measuring shielding efficiency, also for connectors traditionally considered low frequency, has been addressed at a regulatory level.

An experimental method for determining surface transfer impedance of coupled low frequency connectors is still being studied by IEC.

The method chosen by ILME for verification of its system of EMC enclosures and accessories is the **line injection method** based on German military standards **VG 95214-10** and **VG 95214-11**.

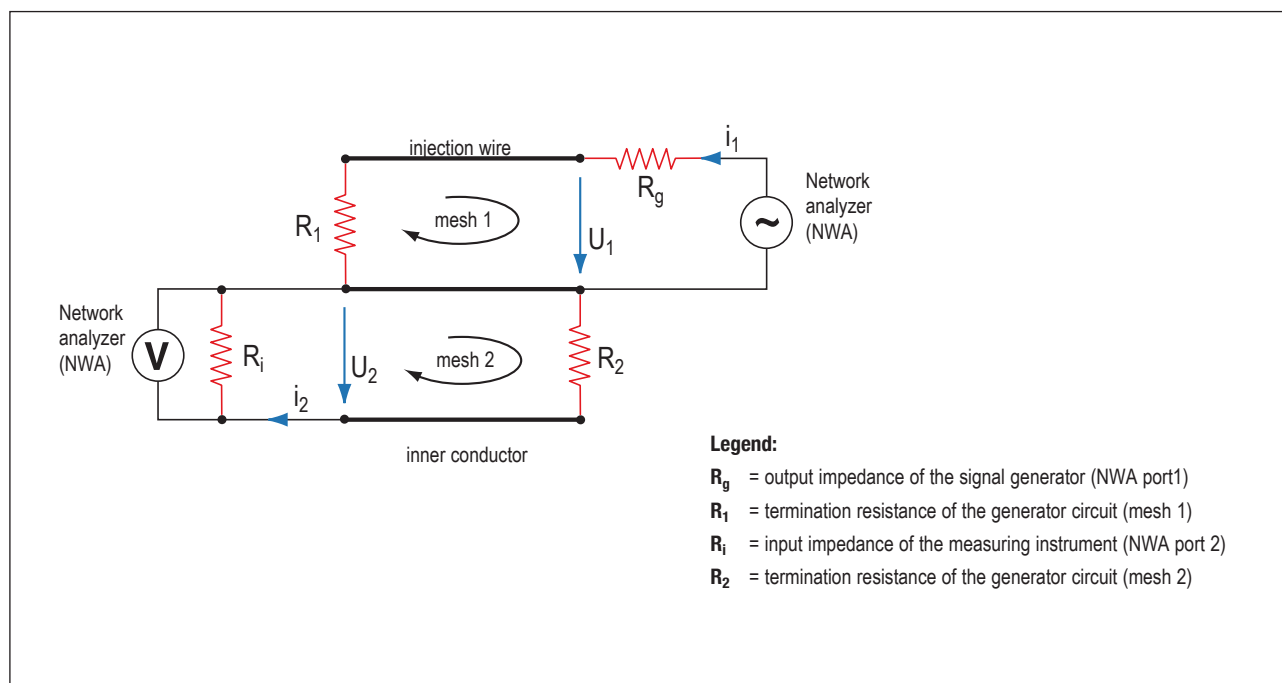


Figure 2



Electromagnetic shielding of connectors: fundamental principles

A signal with a frequency of 0,1 MHz to 1000 MHz generated by port 1 of the measuring device (a network analyzer with 75 Ω output impedance) circulates in the mesh 1 consisting of an insulated conductor (injection wire) resting on the surface of two coupled enclosures (shield), terminating on a calibrated (and shielded) resistance of 75 Ω .

As a result of the current i_1 injected in the mesh 1, an induced voltage U_2 is generated in the mesh 2, consisting of an inner pick-up conductor connected to two contacts at the center of the connector inserts, terminated on another calibrated resistance of 75 Ω (shielded),

in turn earthed on the coupled enclosures which act as a shield.

The voltage is measured on port 2 of the measuring device for S parameters (scattering parameters). The network analyzer sees the device under test as a filter and calculates the measurement providing a graph illustrating the **shielding attenuation** (measured in dB) as a function of frequency in MHz.

The tests were performed on:

- coupled standard enclosures (Figure 3)
- coupled EMC enclosures (Figure 4)

Figure 3 - Standard enclosure diagram

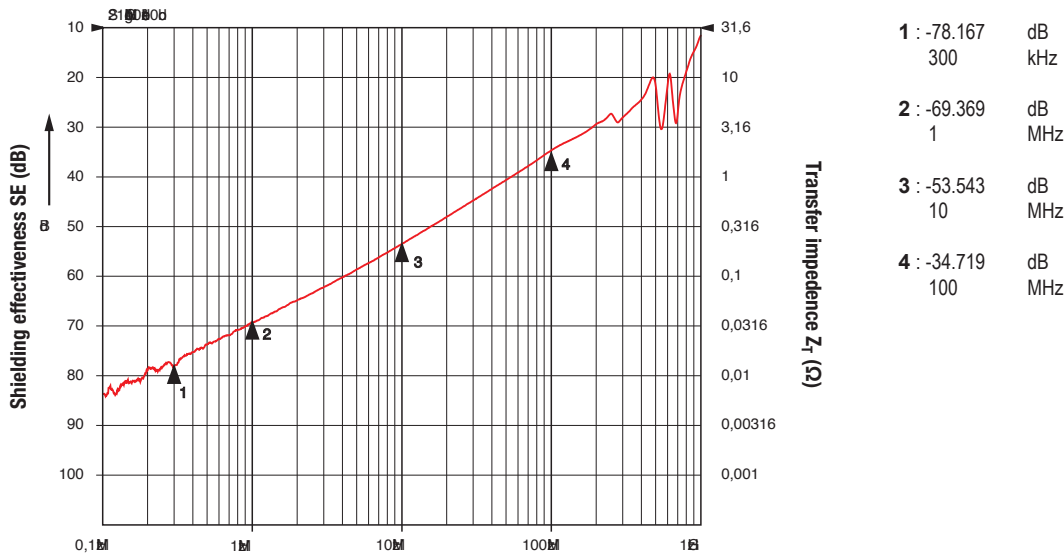
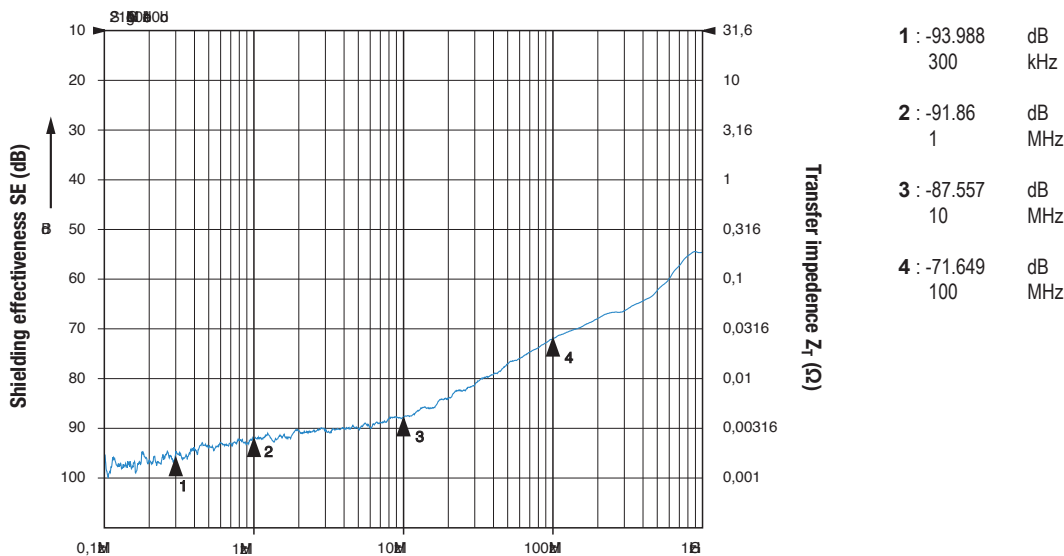


Figure 4 - EMC enclosure diagram

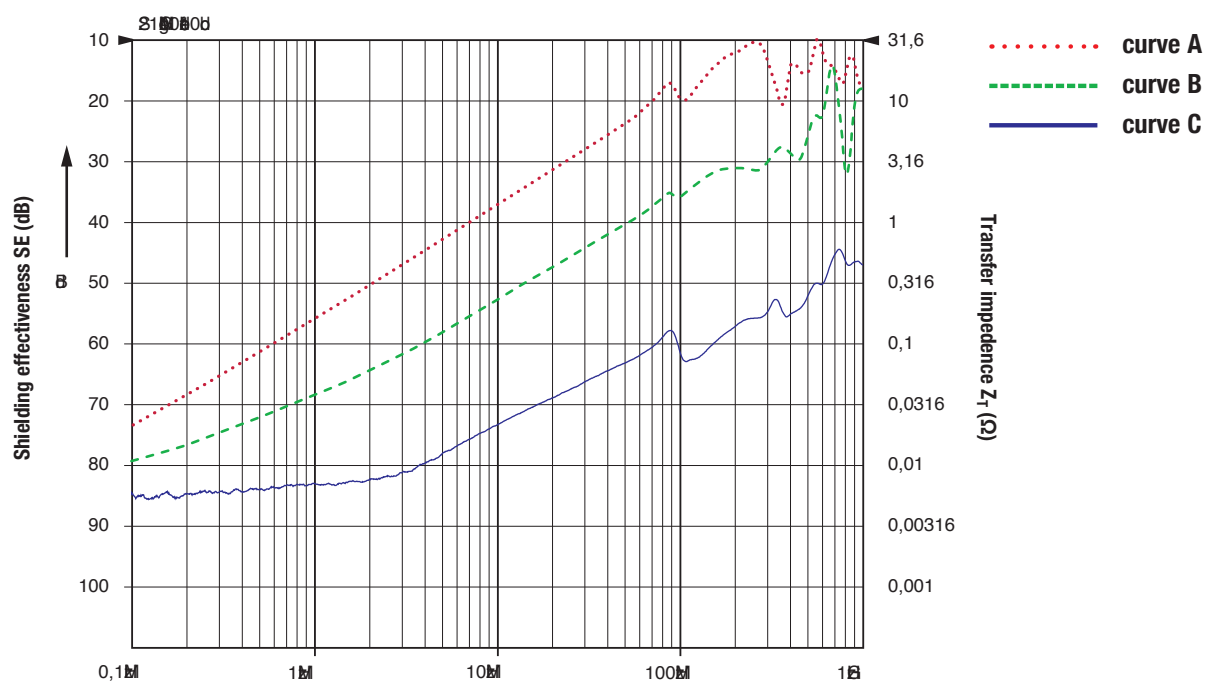


To highlight the influence of the cable gland the shielding attenuation measurements were repeated on:

- coupled standard enclosures with standard cable gland and cable shield earthed to the earth terminal of the connector. **See curve A**
- coupled standard enclosures with EMC cable gland and cable shield earthed to the cable gland. **See curve B**
- coupled EMC enclosures with EMC cable gland and cable shield earthed to the cable gland. **See curve C**

The results are summarized in the diagrams of Figure 5.

Figure 5 - Overview diagrams



NOTE

For the relationship between Shielding effectiveness SE and Transfer impedance (Ω) see also IEC 60512-23-3: $SE = 40 - 20_{\log} 10Z_T$ (dB).

Conclusions

The measurements suggest the following considerations:

- standard enclosures already provide good levels of shielding attenuation;
- when used with EMC cable glands, standard enclosures clearly increase their shielding attenuation;
- EMC enclosures, with better shielding attenuation values, provide further improvements..

EMC series – IL-BRID lever version

Housings and covers – 1 lever – with gasket

size **44.27**

Specialized Applications


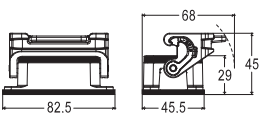

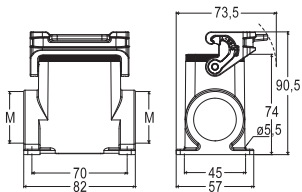


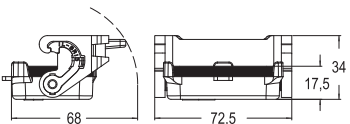


CE UK CA

EN 60529	IP65 / IP66 / IP69
UL 50 / UL 50E	Type 12 / 4
Ambient temperature limits	-40 °C ... +125 °C
Mechanical life (cycles)	≥ 500

(pending: CQC, DNV and BV)

(pending: cURus)

Item	Description	Part No.	Entry	Dimension
	Bulkhead mounting housings, 1 lever and gasket	CLIS 06 L		
	Surface mounting housings, 1 lever and gasket, high construction	MLAPS 06 L25 MLAPS 06 L32	M25 M32	
	Covers, 1 lever and gasket For enclosures with 2 pegs without gasket with loop for hoods 	CLCS 06 LG		

EMC
E

Inserts size 44.27	Poles	Pages	MIXO Modular Inserts	Pages
CNE	16 A 6 + ⊕	B.38	MIXO modules	C.12-93
CCE	16 A 6 + ⊕	B.44	CX 02 T (2-slot sized MIXO frames)	C.95
CSH / JSH S	16 A 6 + ⊕	B.52,58		
CQE / CQEY	16 A 10 + ⊕	B.72,82		
CDD	10 A 24 + ⊕	B.94		
CDSH / CDSH NC	10 A 9 and 6 + ⊕	B.102,108		
CSS	16 A 6 + ⊕	B.118		
CT / CTSE*	16 A 6 + ⊕	B.126,130		

*can be used only in bulkhead mounting housings

Accessories:



CHCP 06
Dust protection cover
Page G.46

EMC series

size **44.27**

Hoods and covers – 2 pegs – without gasket


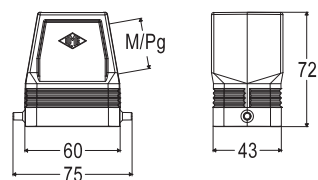

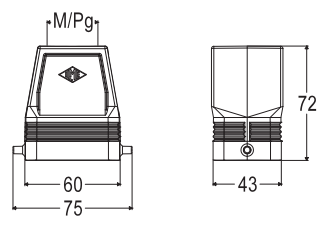

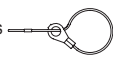

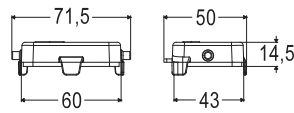
Specialized Applications 

CE UK



EN 60529	IP65 / IP66 / IP69
UL 50 / UL 50E	Type 12 / 4
Ambient temperature limits	-40 °C ... +125 °C
Mechanical life (cycles)	≥ 500

C[®]ALUS ECBT2.E115072 | ECBT8.E115072

Item	Description	Side entry	Top entry	Entry	Dimension
	Hoods, 2 pegs, without gasket, side entry, high construction To be used only with a complete cable gland	MFOS 06 L32 CFOS 06 L21		M32 Pg 21	
	Hoods, 2 pegs, without gasket, top entry, high construction To be used only with a complete cable gland		MFVS 06 L32 CFVS 06 L21	M32 Pg 21	
	Covers, 2 pegs, without gasket For enclosures with 1 lever and gasket with loop for hoods  or with eyelet for housings 	With loop CHCS 06 SL	With eyelet CHCS 06 L		

Inserts size 44.27	Poles	Pages	MIXO Modular Inserts	Pages
CNE	16 A 6 + ⊕	B.38	MIXO modules	C.12-93
CCE	16 A 6 + ⊕	B.44	CX 02 T (2-slot sized MIXO frames)	C.95
CSH / JSH S	16 A 6 + ⊕	B.52,58		
CQE / CQEY	16 A 10 + ⊕	B.72,82		
CDD	10 A 24 + ⊕	B.94		
CDSH / CDSH NC	10 A 9 and 6 + ⊕	B.102,108		
CSS	16 A 6 + ⊕	B.118		

Accessories:



CHCP 06
Dust protection cover
Page G.46

EMC series – IL-BRID lever version

Housings and covers – 2 levers – with gasket

size **57.27**

Specialized Applications


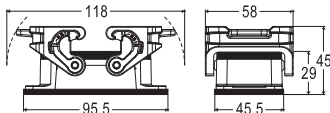

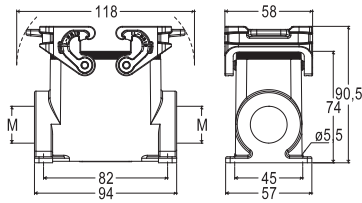

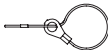
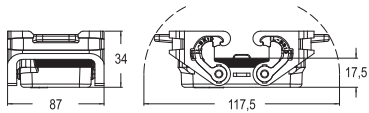


CE UK CA

(pending: CQC, DNV and BV)

(pending: cURus)

EN 60529	IP65 / IP66 / IP69
UL 50 / UL 50E	Type 12 / 4
Ambient temperature limits	-40 °C ... +125 °C
Mechanical life (cycles)	≥ 500

Item	Description	Part No.	Entry	Dimension
	Bulkhead mounting housings, 2 levers and gasket	CLIS 10		
	Surface mounting housings, 2 levers and gasket, high construction	MLAPS 10.25 MLAPS 10.32	M25 M32	
	Covers, 2 levers and gasket For enclosures with 4 pegs without gasket with loop for hoods 	CLCS 10 G		

EMC

E

Inserts size 57.27	Poles	Pages	Inserts size 57.27	Poles	Pages
CNE	16 A	10 + ☉	CT / CTSE*	16 A	10 + ☉
CCE	16 A	10 + ☉	CMCE / CMSH	16 A	3 + 2 (aux.) + ☉
CSH / JSH S	16 A	10 + ☉	CX	40 A/10 A	8/24 + ☉
CSHT	16 A	10 + ☉	*can be used only in bulkhead mounting housings		
CQE / CQEY	16 A	18 + ☉	MIXO Modular Inserts		
CDD	10 A	42 + ☉	Pages		
CDSH	10 A	18 + ☉	MIXO modules	C.12-93	
CSS	16 A	10 + ☉	CX 03 T (3-slot sized MIXO frames)	C.95	

Accessories:



CHCP 10
Dust protection cover
Page G.46

EMC series

Hoods and covers – 4 pegs – without gasket


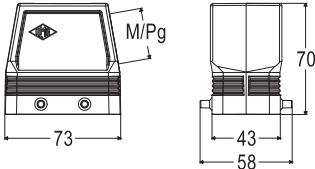

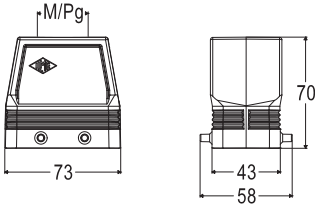


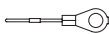
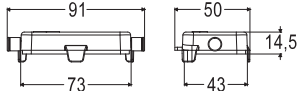
size **57.27**Specialized
Applications

CE UK



EN 60529	IP65 / IP66 / IP69
UL 50 / UL 50E	Type 12 / 4
Ambient temperature limits	-40 °C ... +125 °C
Mechanical life (cycles)	≥ 500

C A U S E C B T 2 . E 1 1 5 0 7 2 | E C B T 8 . E 1 1 5 0 7 2

Item	Description	Side entry	Top entry	Entry	Dimension
	Hoods, 4 pegs, without gasket, side entry, high construction To be used only with a complete cable gland	MFOS 10.32 CFOS 10.21		M32 Pg 21	
	Hoods, 4 pegs, without gasket, top entry, high construction To be used only with a complete cable gland		MFVS 10.32 CFVS 10.21	M32 Pg 21	
	Covers, 2 pegs, without gasket For enclosures with 2 levers and gasket with loop for hoods  or with eyelet for housings 	With loop CHCS 10 S	With eyelet CHCS 10		

Inserts size 57.27	Poles	Pages	Inserts size 57.27	Poles	Pages		
CNE	16 A	10 + ☉	B.39	CMCE / CMSH	16 A	3 + 2 (aux.) + ☉	B.144,149
CCE	16 A	10 + ☉	B.45	CX	40 A/10 A	8/24 + ☉	B.170-171
CSH / JSH S	16 A	10 + ☉	B.53,59				
CSHT	16 A	10 + ☉	B.66				
CQE / CQEY	16 A	18 + ☉	B.73,83				
CDD	10 A	42 + ☉	B.95	MIXO Modular Inserts		Pages	
CDSH	10 A	18 + ☉	B.103	MIXO modules		C.12-93	
CSS	16 A	10 + ☉	B.119	CX 03 T (3-slot sized MIXO frames)		C.95	

Accessories:



CHCP 10
Dust protection
cover
Page G.46

EMC series – IL-BRID lever version

Housings and covers – 2 levers – with gasket

size **77.27**

Specialized Applications


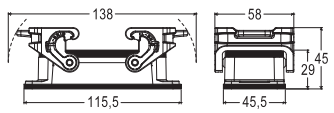

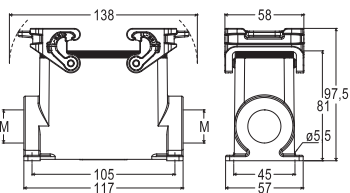

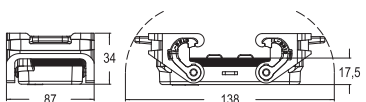
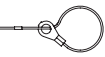


CE UK CA

EN 60529	IP65 / IP66 / IP69
UL 50 / UL 50E	Type 12 / 4
Ambient temperature limits	-40 °C ... +125 °C
Mechanical life (cycles)	≥ 500

(pending: CQC, DNV and BV)

(pending: cURus)

Item	Description	Part No.	Entry	Dimension
	Bulkhead mounting housings, 2 levers and gasket	CLIS 16		
	Surface mounting housings, 2 levers and gasket, high construction	MLAPS 16.32 MLAPS 16.40	M32 M40	
	Covers, 2 levers and gasket	CLCS 16 G		
	For enclosures with 4 pegs without gasket with loop for hoods 			

EMC

E

Inserts size 77.27	Poles	Pages	Inserts size 77.27	Poles	Pages	MIXO Modular Inserts	Pages
CNE	16 + ⊕	B.40	CP / CPY	35 A	6 + ⊕	MIXO modules	C.12-93
CCE	16 A	B.46	CSS	16 A	16 + ⊕	CX 04 T (4-slot sized MIXO frames)	C.95
CSH / JSH S	16 A	B.54,60	CT / CTSE*	16 A	16 + ⊕		
CSHT	16 A	B.67	CT / CTS*	10 A	40 + ⊕		
CQE / CQEY	16 A	B.74,84	CMCE / CMSH	16 A	6 + 2 (aux.) + ⊕		
CQEE	16 A	B.78	CX / CXC	80 A/16 A	4/0, 4/2 + ⊕		
CD	10 A	B.90	CX	40 A/10 A	6/12, 6/36, 9/42 and 12/2 + ⊕		
CDD	10 A	B.94					
CDSH	10 A	B.104					

*can be used only in bulkhead mounting housings

Accessories:



CHCP 16
Dust protection cover
Page G.46

EMC series


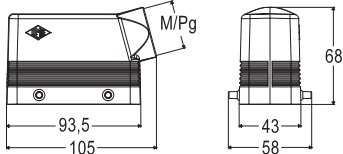

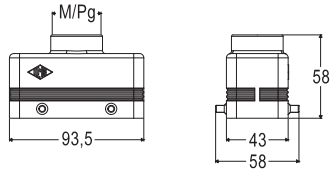

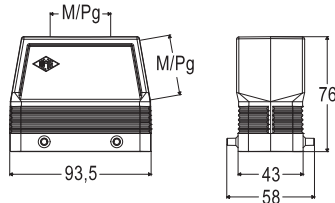


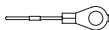
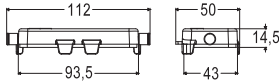
Hoods and covers – 4 pegs – without gasket

size **77.27**Specialized Applications 

CE UK

EN 60529	IP65 / IP66 / IP69
UL 50 / UL 50E	Type 12 / 4
Ambient temperature limits	-40 °C ... +125 °C
Mechanical life (cycles)	≥ 500


 ECBT2.E115072 | ECBT8.E115072

Item	Description	Side entry	Top entry	Entry	Dimension
	Hoods, 4 pegs, without gasket, side entry	MHOS 16.25 MHOS 16.32 CHOS 16		M25 M32 Pg 21	
	Hoods, 4 pegs, without gasket, top entry To be used only with a complete cable gland		MHVS 16.25 MHVS 16.32 CHVS 16	M25 M32 Pg 21	
	Hoods, 4 pegs, without gasket, side or top entry, high construction To be used only with a complete cable gland	MFOS 16.32 MFOS 16.40 CFOS 16.29	MFVS 16.32 MFVS 16.40 CFVS 16.29	M32 M40 Pg 29	
	Covers, 2 pegs, without gasket For enclosures with 2 levers and gasket with loop for hoods  or with eyelet for housings 	With loop CHCS 16 S	With eyelet CHCS 16		

Inserts size 77.27	Poles	Pages	Inserts size 77.27	Poles	Pages	MIXO Modular Inserts	Pages
CNE	16 A	16 + ⊕ B.40	CP / CPY	35 A	6 + ⊕	MIXO modules	C.12-93
CCE	16 A	16 + ⊕ B.46	CSS	16 A	16 + ⊕	CX 04 T (4-slot sized MIXO frames)	C.95
CSH / JSH S	16 A	16 + ⊕ B.54,60	CMCE / CMSH	16 A	6 + 2 (aux.) + ⊕		
CSHT	16 A	16 + ⊕ B.67	CX / CXC	80 A/16 A	4/0, 4/2 + ⊕		
CQE / CQEY	16 A	32 + ⊕ B.74,84	CX	40 A/10 A	6/12, 6/36, 9/42 and 12/2 + ⊕		
CQEE	16 A	40 + ⊕ B.78					
CD	10 A	40 + ⊕ B.90					
CDD	10 A	72 + ⊕ B.94					
CDSH	10 A	27 + ⊕ B.104					

Accessories:



CHCP 16
Dust protection cover
Page G.46

EMC series – IL-BRID lever version

Housings and covers – 2 levers – with gasket

size **104.27**

Specialized Applications


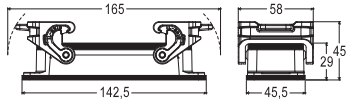

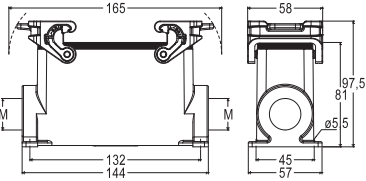

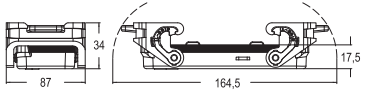
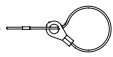


CE UK CA

(pending: CQC, DNV and BV)

(pending: cURus)

EN 60529	IP65 / IP66 / IP69
UL 50 / UL 50E	Type 12 / 4
Ambient temperature limits	-40 °C ... +125 °C
Mechanical life (cycles)	≥ 500

Item	Description	Part No.	Entry	Dimension
	Bulkhead mounting housings, 2 levers and gasket	CLIS 24		
	Surface mounting housings, 2 levers and gasket, high construction	MLAPS 24.32 MLAPS 24.40	M32 M40	
	Covers, 2 levers and gasket	CLCS 24 G		
	For enclosures with 4 pegs without gasket with loop for hoods 			

EMC

E

Inserts size 104.27	Poles	Pages	Inserts size 104.27	Poles	Pages	MIXO Modular Inserts	Pages
CNE	16 A	24 + ⊕	B.41	CSS	16 A	24 + ⊕	B.121
CCE	16 A	24 + ⊕	B.47	CT / CTSE*	16 A	24 + ⊕	B.129,133
CSH / JSH S	16 A	24 + ⊕	B.55,61	CT / CTS*	10 A	64 + ⊕	B.139,141
CSHT	16 A	24 + ⊕	B.68	CMCE / CMSH	16 A	10 + 2 (aux.) + ⊕	B.146,151
CQE / CQEY	16 A	46 + ⊕	B.75,85	CX	100 A/16 A	8/0 and 6/6 + ⊕	B.156-157
CQEE	16 A	64 + ⊕	B.79	CX / CXC	80 A/16 A	4/8 + ⊕	B.161-162
CD	10 A	64 + ⊕	B.91	*can be used only in bulkhead mounting housings			
CDD	10 A	108 + ⊕	B.97				
CDSH	10 A	42 + ⊕	B.105				

Accessories:

CHCP 24
Dust protection cover
Page G.46




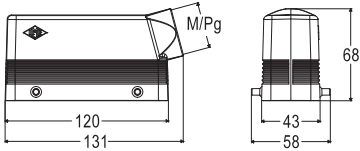

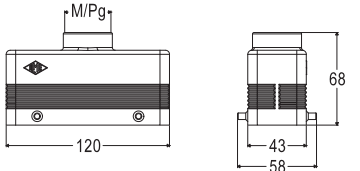

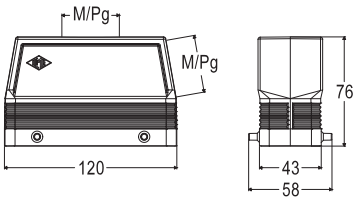

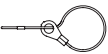
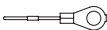
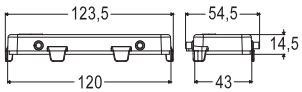
EMC series

Hoods and covers – 4 pegs – without gasket

size **104.27**Specialized Applications 

EN 60529	IP65 / IP66 / IP69
UL 50 / UL 50E	Type 12 / 4
Ambient temperature limits	-40 °C ... +125 °C
Mechanical life (cycles)	≥ 500


 ECBT2.E115072 | ECBT8.E115072

Item	Description	Side entry	Top entry	Entry	Dimension
	Hoods, 4 pegs, without gasket, side entry	MHOS 24.25 MHOS 24.32 CHOS 24		M25 M32 Pg 21	
	Hoods, 4 pegs, without gasket, top entry To be used only with a complete cable gland		MHVS 24.25 MHVS 24.32 CHVS 24	M25 M32 Pg 21	
	Hoods, 4 pegs, without gasket, side or top entry, high construction To be used only with a complete cable gland	MFOS 24.32 MFOS 24.40 CFOS 24.29	MFVS 24.32 MFVS 24.40 CFVS 24.29	M32 M40 Pg 29	
	Covers, 4 pegs, without gasket For enclosures with 2 levers and gasket with loop for hoods  or with eyelet for housings 	With loop CHCS 24 S	With eyelet CHCS 24		

Inserts size 104.27	Poles	Pages	Inserts size 104.27	Poles	Pages	MIXO Modular Inserts	Pages
CNE	16 A	24 + ⊕	B.41	CSS	16 A	24 + ⊕	B.121
CCE	16 A	24 + ⊕	B.47	CMCE / CMSH	16 A	10 + 2 (aux.) + ⊕	B.146,151
CSH / JSH S	16 A	24 + ⊕	B.55,61	CX	100 A/16 A	8/0 and 6/6 + ⊕	B.156-157
CSHT	16 A	24 + ⊕	B.68	CX / CXC	80 A/16 A	4/8 + ⊕	B.161-162
CQE / CQEY	16 A	46 + ⊕	B.75,85				
CQEE	16 A	64 + ⊕	B.79				
CD	10 A	64 + ⊕	B.91				
CDD	10 A	108 + ⊕	B.97				
CDSH	10 A	42 + ⊕	B.105				

Accessories:




CHCP 24
Dust protection cover
Page G.46

EMC series – C-TYPE lever version

Housings and covers – 1 lever – with gasket


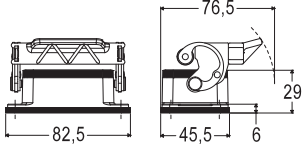

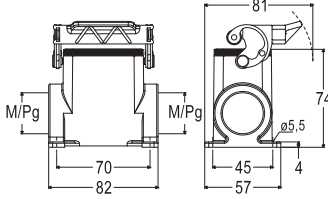


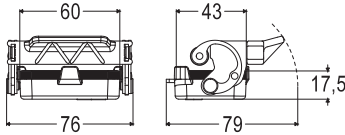
size **44.27**

Specialized Applications 

EN 60529	IP65 / IP66 / IP69
UL 50 / UL 50E	Type 12 / 4
Ambient temperature limits	-40 °C ... +125 °C
Mechanical life (cycles)	≥ 500



CAIUS ECBT2.E115072 | ECBT8.E115072

Item	Description	Part No.	Entry	Dimension
	Bulkhead mounting housings, 1 lever and gasket	CHIS 06 L		
	Surface mounting housings, 1 lever and gasket, high construction	MAPS 06 L32 CAPS 06 L	M32 Pg 21	
	Covers, 1 lever and gasket For enclosures with 2 pegs without gasket with loop for hoods 	CHCS 06 LG		

EMC
E

Inserts size 44.27	Poles	Pages	MIXO Modular Inserts	Pages
CNE	16 A 6 + ⊕	B.38	MIXO modules	C.12-93
CCE	16 A 6 + ⊕	B.44	CX 02 T (2-slot sized MIXO frames)	C.95
CSH / JSH S	16 A 6 + ⊕	B.52,58		
CQE / CQEY	16 A 10 + ⊕	B.72,82		
CDD	10 A 24 + ⊕	B.94		
CDSH / CDSH NC	10 A 9 and 6 + ⊕	B.102,108		
CSS	16 A 6 + ⊕	B.118		
CT / CTSE*	16 A 6 + ⊕	B.126,130		

*can be used only in bulkhead mounting housings

Complete with:  **Hoods**
Page E.209

Accessories:  **CHCP 06**
Dust protection cover
Page G.46

EMC series – C-TYPE lever version

size **57.27**

Housings and covers – 2 levers – with gasket

Specialized Applications

CE UK CA



EN 60529	IP65 / IP66 / IP69
UL 50 / UL 50E	Type 12 / 4
Ambient temperature limits	-40 °C ... +125 °C
Mechanical life (cycles)	≥ 500

ECBT2.E115072 | ECBT8.E115072

Item	Description	Part No.	Entry	Dimension
	Bulkhead mounting housings, 2 levers and gasket	CHIS 10		
	Surface mounting housings, 2 levers and gasket, high construction	MAPS 10.32 CAPS 10.21	M32 Pg 21	
	Covers, 2 levers and gasket For enclosures with 4 pegs without gasket with loop for hoods	CHCS 10 G		

Inserts size 57.27	Poles	Pages	Inserts size 57.27	Poles	Pages		
CNE	16 A	10 + ⊕	B.39	CT / CTSE*	16 A	10 + ⊕	B.127,131
CCE	16 A	10 + ⊕	B.45	CMCE / CMSH	16 A	3 + 2 (aux.) + ⊕	B.144,149
CSH / JSH S	16 A	10 + ⊕	B.53,59	CX	40 A/10 A	8/24 + ⊕	B.170-171
CSHT	16 A	10 + ⊕	B.66	*can be used only in bulkhead mounting housings			
CQE / CQEY	16 A	18 + ⊕	B.73,83				
CDD	10 A	42 + ⊕	B.95				
CDSH	10 A	18 + ⊕	B.103				
CSS	16 A	10 + ⊕	B.119				
			MIXO Modular Inserts	Pages			
			MIXO modules	C.12-93			
			CX 03 T (3-slot sized MIXO frames)	C.95			

Complete with:


Hoods
Page E.211

Accessories:


CHCP 10
Dust protection
cover
Page G.46

EMC series – C-TYPE lever version

Housings and covers – 2 levers – with gasket

size **77.27**


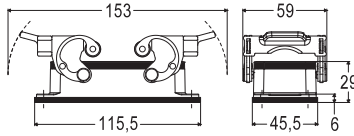

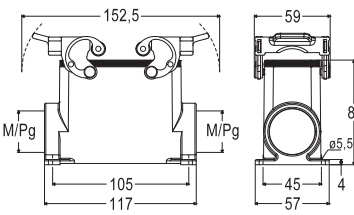

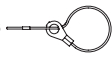
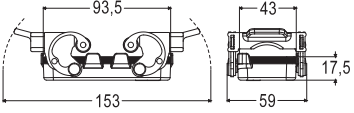
Specialized Applications



EN 60529	IP65 / IP66 / IP69
UL 50 / UL 50E	Type 12 / 4
Ambient temperature limits	-40 °C ... +125 °C
Mechanical life (cycles)	≥ 500



CEBUS ECBT2.E115072 | ECBT8.E115072

Item	Description	Part No.	Entry	Dimension
	Bulkhead mounting housings, 2 levers and gasket	CHIS 16		
	Surface mounting housings, 2 levers and gasket, high construction	MAPS 16.32 CAPS 16.21	M32 Pg 21	
	Covers, 2 levers and gasket For enclosures with 4 pegs without gasket with loop for hoods 	CHCS 16 G		

EMC
E

Inserts size 77.27	Poles	Pages	Inserts size 77.27	Poles	Pages	MIXO Modular Inserts	Pages
CNE	16 + ⊕	B.40	CP / CPY	35 A	6 + ⊕	MIXO modules	C.12-93
CCE	16 A	B.46	CSS	16 A	16 + ⊕	CX 04 T (4-slot sized MIXO frames)	C.95
CSH / JSH S	16 A	B.54,60	CT / CTSE*	16 A	16 + ⊕		
CSHT	16 A	B.67	CT / CTS*	10 A	40 + ⊕		
CQE / CQEY	16 A	B.74,84	CMCE / CMSH	16 A	6 + 2 (aux.) + ⊕		
CQEE	16 A	B.78	CX / CXC	80 A/16 A	4/0, 4/2 + ⊕		
CD	10 A	B.90	CX	40 A/10 A	6/12, 6/36, 9/42 and 12/2 + ⊕		
CDD	10 A	B.94					
CDSH	10 A	B.104					

*can be used only in bulkhead mounting housings

Complete with:



Hoods
Page E.213

Accessories:



CHCP 16
Dust protection cover
Page G.46

EMC series – C-TYPE lever version


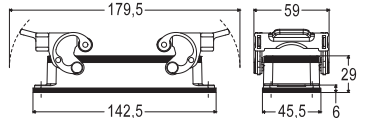

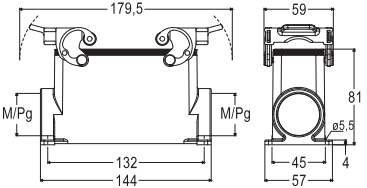


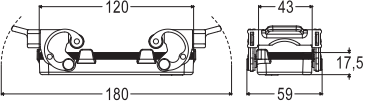
size **104.27**

Housings and covers – 2 levers – with gasket

Specialized Applications
CE UK


EN 60529	IP65 / IP66 / IP69
UL 50 / UL 50E	Type 12 / 4
Ambient temperature limits	-40 °C ... +125 °C
Mechanical life (cycles)	≥ 500

ALUS ECBT2.E115072 | ECBT8.E115072

Item	Description	Part No.	Entry	Dimension
	Bulkhead mounting housings, 2 levers and gasket	CHIS 24		
	Surface mounting housings, 2 levers and gasket, high construction	MAPS 24.32 CAPS 24.21	M32 Pg 21	
	Covers, 2 levers and gasket For enclosures with 4 pegs without gasket with loop for hoods 	CHCS 24 G		

Inserts size 104.27	Poles	Pages	Inserts size 104.27	Poles	Pages	MIXO Modular Inserts	Pages		
CNE	16 A	24 + ☉	B.41	CSS	16 A	24 + ☉	B.121	MIXO modules	C.12-93
CCE	16 A	24 + ☉	B.47	CT / CTSE*	16 A	24 + ☉	B.129,133	CX 06 T (6-slot sized MIXO frames)	C.95
CSH / JSH S	16 A	24 + ☉	B.55,61	CT / CTS*	10 A	64 + ☉	B.139,141		
CSHT	16 A	24 + ☉	B.68	CMCE / CMSH	16 A	10 + 2 (aux.) + ☉	B.146,151		
CQE / CQEY	16 A	46 + ☉	B.75,85	CX	100 A/16 A	8/0 and 6/6 + ☉	B.156-157		
CQEE	16 A	64 + ☉	B.79	CX / CXC	80 A/16 A	4/8 + ☉	B.161-162		
CD	10 A	64 + ☉	B.91	*can be used only in bulkhead mounting housings					
CDD	10 A	108 + ☉	B.97						
CDSH	10 A	42 + ☉	B.105						

Complete with:


Hoods
Page E.215

Accessories:


CHCP 24
Dust protection
cover
Page G.46

Panel cut-out drawings

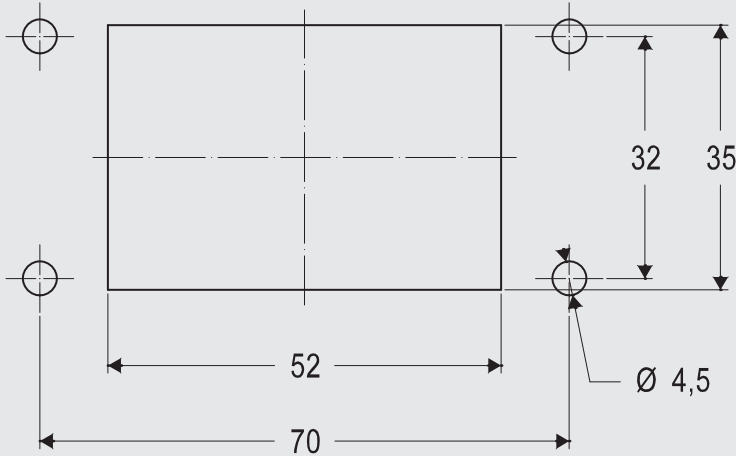
For EMC series bulkhead mounting housings

To guarantee the declared IP degree of protection of the housings reported in this catalogue, according to EN IEC 60529 or to the relevant Type rating per ANSI/UL 50 and 50E (for those products bearing approval to those ratings), the surface of the mounting panel must meet the following requirements (definitions are provided in ISO 4287 standard):

Waviness $Wt \leq 0,2$ mm over a distance of 200 mm (measured on the panel without load)
Roughness $Ra \leq 16$ μ m

Scale 1:1

Size 44.27



Required screws: 4
Screws size: M4
Recommended torque:
 0,8 – 1,2 Nm / 7.1 – 10.6 lb.in

Size 57.27



Required screws: 4
Screws size: M4
Recommended torque:
 0,8 – 1,2 Nm / 7.1 – 10.6 lb.in

Notes: The values of tightening torque indicated above are just recommended values, that must be related – by the designer of the final application – to the resistance class of the screws (not included), with the assumption that the mounting panel is sufficiently rigid (stiff). If the deflection of the panel, under the effect of tightening the screws, is greater than 0,7 mm over a distance of 100 mm, it is

necessary to use the counter-flanges mentioned in our catalogue or the special flange gaskets available upon request (please contact our Sales Department).

Panel cut-out drawings

For EMC series bulkhead mounting housings

To guarantee the declared IP degree of protection of the housings reported in this catalogue, according to EN IEC 60529 or to the relevant Type rating per ANSI/UL 50 and 50E (for those products bearing approval to those ratings), the surface of the mounting panel must meet the following requirements (definitions are provided in ISO 4287 standard):

Waviness $Wt \leq 0,2$ mm over a distance of 200 mm
(measured on the panel without load)

Roughness $Ra \leq 16$ μ m

Scale 1:1

Size 77.27



Required screws: 4
Screws size: M4
Recommended torque:
0,8 – 1,2 Nm / 7.1 – 10.6 lb.in

Size 104.27



Required screws: 4
Screws size: M4
Recommended torque:
0,8 – 1,2 Nm / 7.1 – 10.6 lb.in

Notes: The values of tightening torque indicated above are just recommended values, that must be related – by the designer of the final application – to the resistance class of the screws (not included), with the assumption that the mounting panel is sufficiently rigid (stiff). If the deflection of the panel, under the effect of tightening the screws, is greater than 0,7 mm over a distance of 100 mm, it is

necessary to use the counter-flanges mentioned in our catalogue or the special flange gaskets available upon request (please contact our Sales Department).



T-TYPE enclosures for Heavy-Duty Applications

T-TYPE/W enclosures for Aggressive Environments



T-TYPE and T-TYPE/W series

Alongside the wide range of traditional metallic enclosures for multipole connectors, ILME first “pioneered” a series of enclosures in self-extinguishing thermoplastic material in the standard sizes 44.27, 57.27, 77.27, and 104.27.

The series design results in significant structural solidity and mechanical robustness, offering a technical, cost-effective solution for protecting connector inserts.

❖ Markings and Approvals

- CE and UK markings, EAC not applicable
- UL certified for USA and Canada for degrees of protection (enclosure type ratings, equivalent to NEMA rating):

T-TYPE Standard: Type 12.

T-TYPE/W: Type 12 – Type 4 / 4X Indoor Use Only.

- IP65 / IP66 / IP69 degree of protection
- RoHS: compliant



Watch our clip

SUM-UP

T-TYPE series

HEAVY-DUTY APPLICATIONS

- > Enclosures in thermoplastic material, dark grey RAL 7012 colour, with high thicknesses providing structural solidity and durability
- > Built-in polyurethane gaskets
- > Locking levers in thermoplastic material colour grey RAL 7001
- > M25, M32 and M40 threaded cable entries
- > IP65 degree of protection according to EN 60529
- > UL TYPE 12 degree of protection according to ANSI/UL50
- > Each enclosure carries its own part number, thread/size, conformity markings and UL type rating
- > Ambient temperature range: -40 °C / +90 °C

T-TYPE/W series

AGGRESSIVE ENVIRONMENTS

- > Enclosures in thermoplastic material, dark grey RAL 7012 colour, with high thicknesses providing structural solidity and durability
- > Built-in FKM fluoroelastomer sealing gaskets
- > Locking levers in thermoplastic material colour grey RAL 7001
- > M25, M32 and M40 threaded cable entries
- > IP65 / IP66 / IP69 degree of protection according to EN 60529
- > UL TYPE 12 – TYPE 4 / 4X Indoor Use Only degree of protection according to ANSI/UL50
- > Each enclosure carries its own part number, thread size and conformity markings and UL type rating
- > Ambient temperature range: -40 °C / +90 °C

FOCUS

T-TYPE/W sealing gaskets

The characterizing element of the T-TYPE and T-TYPE/W series is the **different sealing gasket material**, while hoods and covers without sealing gaskets are the same.



Polyurethane
sealing gaskets

T-TYPE series



FKM
sealing gaskets

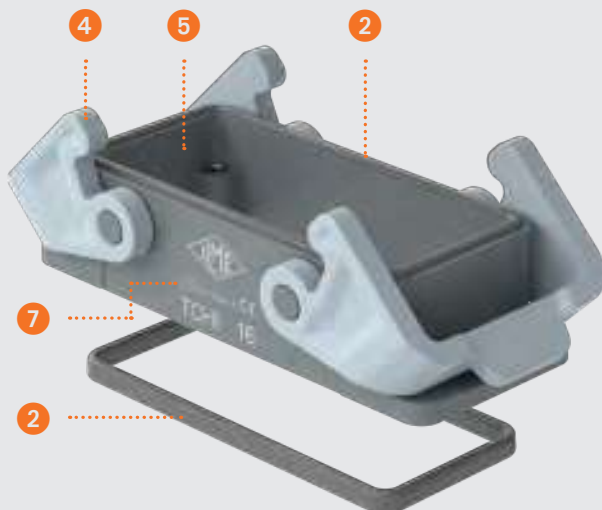
T-TYPE/W series



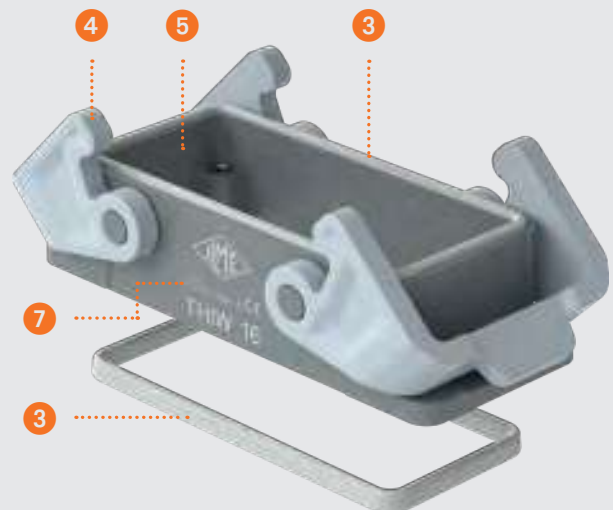
T-TYPE enclosures for Standard Heavy Duty Applications

T-TYPE/W enclosures for Aggressive Environments

TECHNICAL FEATURES



T-TYPE series
HEAVY-DUTY APPLICATIONS



T-TYPE/W series
AGGRESSIVE ENVIRONMENTS

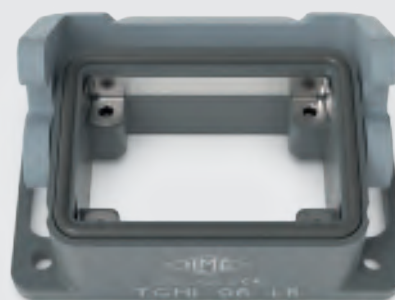
- 1 **Construction:** Structurally solid and mechanically robust, built using BC-MUL® moulding technique together with the use of MIL.BOX® UL 94V-2 material. T-TYPE series is particularly resistant to the main pollutants present in industrial environments.
 - 2 **T-TYPE Standard gaskets:** T-TYPE sealing gaskets are produced in **Polyurethane**, using the FIPFG technology (Formed-In-Place-Foam Gasket). They are designed to be incorporated on the bottom of bulkhead mounting housings, avoiding loose parts for easier connector installation.
 - 3 **T-TYPE/W gaskets:** Sealing gaskets for T-TYPE/W are produced in oil-resistant **FKM (Fluorelastomer)**.
 - 4 **Levers:** The locking levers have been produced in self-extinguishing thermoplastic material, grey RAL 7001 colour. Improved ergonomics and handling.
 - 5 **Dimensions:** The internal dimensions allow mounting of all connector inserts in their relevant sizes. The external dimensions of the bulkhead mounting housings are similar to those of the corresponding metallic enclosures (standard panel cut-outs and fixing holes).
- Hoods offer an inner cabling space similar to the “high” construction models of the corresponding metal enclosures. Other characteristics comply with the applicable safety standard for electrical connectors, IEC/ EN 61984.
- 6 **Cable entries:** The housing and hood cable entries are available with metric thread, respectively:
 - **M25 or M32** for smaller sizes 44.27 and 57.27
 - **M32 or M40** for larger sizes 77.27 and 104.27
 - 7 **Markings:** Each enclosure carries its own part number and conformity markings.
 - 8 **Hoods:** As the characterizing element of the T-TYPE/W series is the different sealing gasket material, hoods and covers without sealing gaskets for this series are the same of T-TYPE Standard.

ACCESSORIES

PE Jumpers

For T-TYPE standard and T-TYPE /W, enclosure versions with pre-installed PE jumpers (also known as “bridges,” hence the suffix B to identify such variants) are available upon request.

Example: TCHI 06 LB is the enclosure version with pre-installed PE jumpers of the standard TCHI 06 L.




T-TYPE series – Insulating

size **44.27**

T-TYPE Housings and hoods for Heavy-Duty Applications
 T-TYPE/W Housings and hoods for Aggressive Environments

Aggressive Environments 


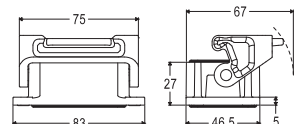

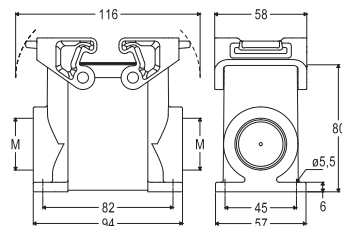

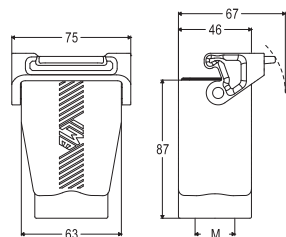
Heavy-Duty Applications 

EN 60529	T-TYPE: IP65 T-TYPE/W: IP65 / IP66 / IP69
UL 50 / UL 50E	T-TYPE: Type 12 T-TYPE/W: Type 12 – Type 4 / 4X Indoor Use Only
Ambient temperature limits	-40 °C ... +90 °C
Mechanical life (cycles)	≥ 500

CE UK

 (pending: CQC)

 ECBT2.E115072 | ECBT8.E115072


Item	Description	T-TYPE	T-TYPE/W	Entry	Dimension
	Bulkhead mounting housings, 1 lever and gasket - PUR gasket for T-TYPE - FKM gasket for T-TYPE/W	TCHI 06 L	THIW 06 L		
	Surface mounting housings, 1 lever and gasket, high construction - PUR gasket for T-TYPE - FKM gasket for T-TYPE/W Supplied with an open threaded entry and diametrically opposite a closed threaded entry which can be opened by the user if required (with suitable tool).	TMAP 06 L25 TMAP 06 L32	TAPW 06 L25 TAPW 06 L32	M25 M32	
	Hoods, 1 lever and gasket, top entry, high construction - PUR gasket for T-TYPE - FKM gasket for T-TYPE/W	TMAV 06 LG25 TMAV 06 LG32	TAVW 06 LG25 TAVW 06 LG32	M25 M32	

T-TYPE and T-TYPE/W

E

Inserts size 44.27	Poles	Pages	MIXO Modular Inserts	Pages	
CNE	16 A	6 + ⊕	B.38	MIXO modules	C.12-93
CCE	16 A	6 + ⊕	B.44	CX 02 T (2-slot sized MIXO frames)	C.95
CSH / JSH S	16 A	6 + ⊕	B.52,58		
CQE / CQEY	16 A	10 + ⊕	B.72,82		
CDD	10 A	24 + ⊕	B.94		
CDSH / CDSH NC	10 A	9 and 6 + ⊕	B.102,108		
CSS	16 A	6 + ⊕	B.118		

Accessories:

 **CR BPE**
PE jumpers
Page E.236

T-TYPE series – Insulating

Hoods – 2 pegs

size 44.27

Aggressive
Environments




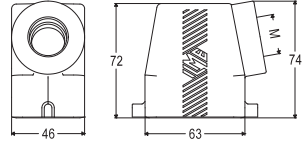

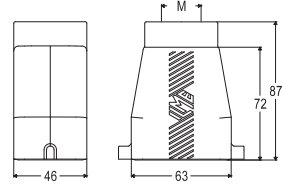
Heavy-Duty
Applications



EN 60529	IP65
UL 50 / UL 50E	Type 12
Ambient temperature limits	-40 °C ... +90 °C
Mechanical life (cycles)	≥ 500



CE UK CA
CEC DNV
CIRUS ECBT2.E115072 | ECBT8.E115072

Item	Description	Part No.	Entry	Dimension
	Hoods, 2 pegs, side entry, high construction, without gasket	TMAO 06 L25 TMAO 06 L32	M25 M32	
	Hoods, 2 pegs, top entry, high construction, without gasket	TMAV 06 L25 TMAV 06 L32	M25 M32	

Inserts size 44.27	Poles	Pages	MIXO Modular Inserts	Pages
CNE	16 A 6 + ⊕	B.38	MIXO modules	C.12-93
CCE	16 A 6 + ⊕	B.44	CX 02 T (2-slot sized MIXO frames)	C.95
CSH / JSH S	16 A 6 + ⊕	B.52,58		
CQE / CQEY	16 A 10 + ⊕	B.72,82		
CDD	10 A 24 + ⊕	B.94		
CDSH / CDSH NC	10 A 9 and 6 + ⊕	B.102,108		
CSS	16 A 6 + ⊕	B.118		

Accessories:



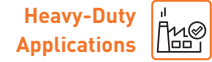
CR BPE
PE jumpers

Page E.236

T-TYPE series – Insulating

size **57.27**

T-TYPE Housings and hoods for Heavy-Duty Applications
 T-TYPE/W Housings and hoods for Aggressive Environments


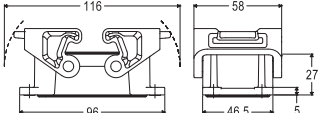

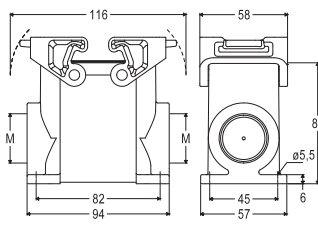

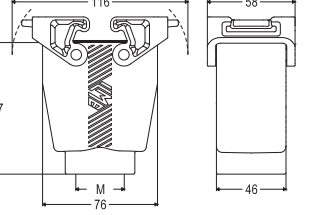


EN 60529	T-TYPE: IP65 T-TYPE/W: IP65 / IP66 / IP69
UL 50 / UL 50E	T-TYPE: Type 12 T-TYPE/W: Type 12 – Type 4 / 4X Indoor Use Only
Ambient temperature limits	-40 °C ... +90 °C
Mechanical life (cycles)	≥ 500



DNV VERITAS (pending: CQC)

CEC® ECBT2.E115072 | ECBT8.E115072

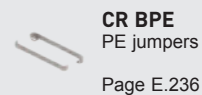
Item	Description	T-TYPE	T-TYPE/W	Entry	Dimension
	Bulkhead mounting housings, 2 levers and gasket - PUR gasket for T-TYPE - FKM gasket for T-TYPE/W	TCHI 10	THIW 10		
	Surface mounting housings, 2 levers and gasket, high construction - PUR gasket for T-TYPE - FKM gasket for T-TYPE/W Supplied with an open threaded entry and diametrically opposite a closed threaded entry which can be opened by the user if required (with suitable tool).	TMAP 10.25 TMAP 10.32	TAPW 10.25 TAPW 10.32	M25 M32	
	Hoods, 2 levers and gasket, top entry, high construction - PUR gasket for T-TYPE - FKM gasket for T-TYPE/W	TMAV 10 G25 TMAV 10 G32	TAVW 10 G25 TAVW 10 G32	M25 M32	

T-TYPE and T-TYPE/W

E

Inserts size 57.27	Poles	Pages	Inserts size 57.27	Poles	Pages		
CNE	16 A	10 + ☉	B.39	CMCE / CMSH	16 A	3 + 2 (aux.) + ☉	B.144,149
CCE	16 A	10 + ☉	B.45	CX	40 A/10 A	8/24 + ☉	B.170-171
CSH / JSH S	16 A	10 + ☉	B.53,59				
CSHT	16 A	10 + ☉	B.66				
CQE / CQEY	16 A	18 + ☉	B.73,83				
CDD	10 A	42 + ☉	B.95				
CDSH	10 A	18 + ☉	B.103				
CSS	16 A	10 + ☉	B.119				
				MIXO Modular Inserts		Pages	
				MIXO modules		C.12-93	
				CX 03 T (3-slot sized MIXO frames)		C.95	

Accessories:



T-TYPE series – Insulating

Hoods – 4 pegs

size 57.27

Aggressive
Environments



Heavy-Duty
Applications



EN 60529	IP65
UL 50 / UL 50E	Type 12
Ambient temperature limits	-40 °C ... +90 °C
Mechanical life (cycles)	≥ 500

CE UK
CA



CEC DNV
 ECBT2.E115072 | ECBT8.E115072

Item	Description	Part No.	Entry	Dimension
	Hoods, 4 pegs, side entry, high construction, without gasket	TMAO 10.25 TMAO 10.32	M25 M32	
	Hoods, 4 pegs, top entry, high construction, without gasket	TMAV 10.25 TMAV 10.32	M25 M32	

Inserts size 57.27	Poles	Pages	Inserts size 57.27	Poles	Pages
CNE	16 A	10 + ☉ B.39	CMCE / CMSH	16 A	3 + 2 (aux.) + ☉ B.144,149
CCE	16 A	10 + ☉ B.45	CX	40 A/10 A	8/24 + ☉ B.170-171
CSH / JSH S	16 A	10 + ☉ B.53,59			
CSHT	16 A	10 + ☉ B.66			
CQE / CQEY	16 A	18 + ☉ B.73,83			
CDD	10 A	42 + ☉ B.95			
CDSH	10 A	18 + ☉ B.103			
CSS	16 A	10 + ☉ B.119			
			MIXO Modular Inserts		Pages
			MIXO modules		C.12-93
			CX 03 T (3-slot sized MIXO frames)		C.95

Accessories:



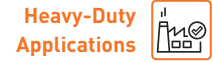
CR BPE
PE jumpers

Page E.236

T-TYPE series – Insulating

size **77.27**

T-TYPE Housings and hoods for Heavy-Duty Applications
 T-TYPE/W Housings and hoods for Aggressive Environments


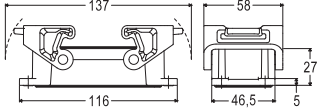

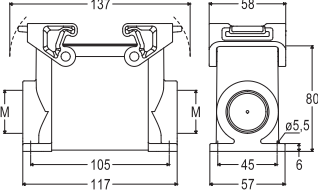

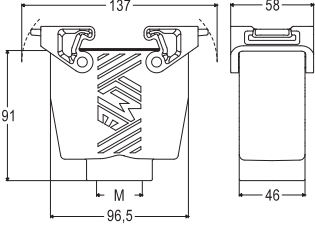


EN 60529	T-TYPE: IP65 T-TYPE/W: IP65 / IP66 / IP69
UL 50 / UL 50E	T-TYPE: Type 12 T-TYPE/W: Type 12 – Type 4 / 4X Indoor Use Only
Ambient temperature limits	-40 °C ... +90 °C
Mechanical life (cycles)	≥ 500



DNV VERITAS (pending: CQC)

CAUS ECBT2.E115072 | ECBT8.E115072

Item	Description	T-TYPE	T-TYPE/W	Entry	Dimension
	Bulkhead mounting housings, 2 levers and gasket - PUR gasket for T-TYPE - FKM gasket for T-TYPE/W	TCHI 16	THIW 16		
	Surface mounting housings, 2 levers and gasket, high construction - PUR gasket for T-TYPE - FKM gasket for T-TYPE/W Supplied with an open threaded entry and diametrically opposite a closed threaded entry which can be opened by the user if required (with suitable tool).	TMAP 16.32 TMAP 16.40	TAPW 16.32 TAPW 16.40	M32 M40	
	Hoods, 2 levers and gasket, top entry, high construction - PUR gasket for T-TYPE - FKM gasket for T-TYPE/W	TMAV 16 G32 TMAV 16 G40	TAVW 16 G32 TAVW 16 G40	M32 M40	

T-TYPE and T-TYPE/W

E

Inserts size 77.27	Poles	Pages	Inserts size 77.27	Poles	Pages	MIXO Modular Inserts	Pages
CNE	16 A	16 + ☉ B.40	CP / CPY	35 A	6 + ☉ B.112,114	MIXO modules	C.12-93
CCE	16 A	16 + ☉ B.46	CSS	16 A	16 + ☉ B.120	CX 04 T (4-slot sized MIXO frames)	C.95
CSH / JSH S	16 A	16 + ☉ B.54,60	CMCE / CMSH	16 A	6 + 2 (aux.) + ☉ B.145,150		
CSHT	16 A	16 + ☉ B.67	CX / CXC	80 A/16 A	4/0, 4/2 + ☉ B.158-160		
CQE / CQEY	16 A	32 + ☉ B.74,84	CX	40 A/10 A	6/12, 6/36, 9/42 and 12/2 + ☉ B.163-164, 168-169		
CQEE	16 A	40 + ☉ B.78					
CD	10 A	40 + ☉ B.90					
CDD	10 A	72 + ☉ B.94					
CDSH	10 A	27 + ☉ B.104					

Accessories:



CR BPE
PE jumpers

Page E.236

T-TYPE series – Insulating

Hoods – 4 pegs

size 77.27


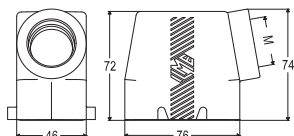

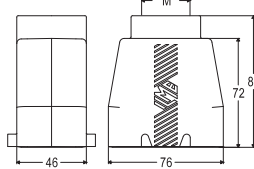
**Aggressive
Environments**

**Heavy-Duty
Applications**



EN 60529	IP65
UL 50 / UL 50E	Type 12
Ambient temperature limits	-40 °C ... +90 °C
Mechanical life (cycles)	≥ 500


RUUS

ECBT2.E115072 | ECBT8.E115072

Item	Description	Part No.	Entry	Dimension
	Hoods, 4 pegs, side entry, high construction, without gasket	TMAO 16.32 TMAO 16.40	M32 M40	
	Hoods, 4 pegs, top entry, high construction, without gasket	TMAV 16.32 TMAV 16.40	M32 M40	

Inserts size 77.27	Poles	Pages	Inserts size 77.27	Poles	Pages	MIXO Modular Inserts	Pages
CNE	16 A	16 + ☉ B.40	CP / CPY	35 A	6 + ☉ B.112,114	MIXO modules	C.12-93
CCE	16 A	16 + ☉ B.46	CSS	16 A	16 + ☉ B.120	CX 04 T (4-slot sized MIXO frames)	C.95
CSH / JSH S	16 A	16 + ☉ B.54,60	CMCE / CMSH	16 A	6 + 2 (aux.) + ☉ B.145,150		
CSHT	16 A	16 + ☉ B.67	CX / CXC	80 A/16 A	4/0, 4/2 + ☉ B.158-160		
CQE / CQEY	16 A	32 + ☉ B.74,84	CX	40 A/10 A	6/12, 6/36, 9/42 and 12/2 + ☉ B.163-164, 168-169		
CQEE	16 A	40 + ☉ B.78					
CD	10 A	40 + ☉ B.90					
CDD	10 A	72 + ☉ B.94					
CDSH	10 A	27 + ☉ B.104					

Accessories:



CR BPE
PE jumpers
Page E.236

T-TYPE series – Insulating

size **104.27**

T-TYPE Housings and hoods for Heavy-Duty Applications
 T-TYPE/W Housings and hoods for Aggressive Environments


Aggressive Environments 


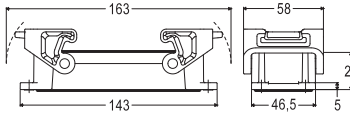

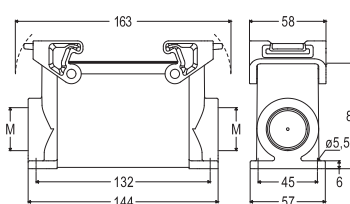

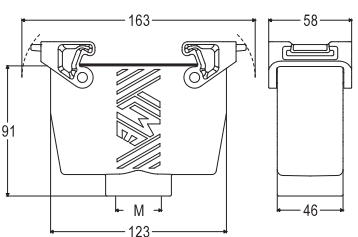
Heavy-Duty Applications 

EN 60529	T-TYPE: IP65 T-TYPE/W: IP65 / IP66 / IP69
UL 50 / UL 50E	T-TYPE: Type 12 T-TYPE/W: Type 12 – Type 4 / 4X Indoor Use Only
Ambient temperature limits	-40 °C ... +90 °C
Mechanical life (cycles)	≥ 500

CE UK

 (pending: CQC)

 ECBT2.E115072 | ECBT8.E115072


Item	Description	T-TYPE	T-TYPE/W	Entry	Dimension
	Bulkhead mounting housings, 2 levers and gasket - PUR gasket for T-TYPE - FKM gasket for T-TYPE/W	TCHI 24	THIW 24		
	Surface mounting housings, 2 levers and gasket, high construction - PUR gasket for T-TYPE - FKM gasket for T-TYPE/W Supplied with an open threaded entry and diametrically opposite a closed threaded entry which can be opened by the user if required (with suitable tool).	TMAP 24.32 TMAP 24.40	TAPW 24.32 TAPW 24.40	M32 M40	
	Hoods, 2 levers and gasket, top entry, high construction - PUR gasket for T-TYPE - FKM gasket for T-TYPE/W	TMAV 24 G32 TMAV 24 G40	TAVW 24 G32 TAVW 24 G40	M32 M40	

T-TYPE and T-TYPE/W

E

Inserts size 104.27	Poles	Pages	Inserts size 104.27	Poles	Pages	MIXO Modular Inserts	Pages
CNE	16 A	24 + ⊕	B.41	CSS	16 A	24 + ⊕	B.121
CCE	16 A	24 + ⊕	B.47	CMCE / CMSH	16 A	10 + 2 (aux.) + ⊕	B.146,151
CSH / JSH S	16 A	24 + ⊕	B.55,61	CX	100 A/16 A	8/0 and 6/6 + ⊕	B.156-157
CSHT	16 A	24 + ⊕	B.68	CX / CXC	80 A/16 A	4/8 + ⊕	B.161-162
CQE / CQEY	16 A	46 + ⊕	B.75,85				
CQEE	16 A	64 + ⊕	B.79				
CD	10 A	64 + ⊕	B.91				
CDD	10 A	108 + ⊕	B.97				
CDSH	10 A	42 + ⊕	B.105				

Accessories:

 **CR BPE**
PE jumpers
Page E.236

T-TYPE series – Insulating

Hoods – 4 pegs

size 104.27

Aggressive
Environments



Heavy-Duty
Applications


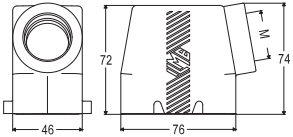

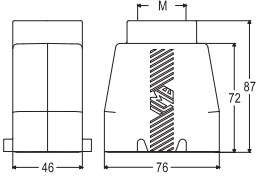


EN 60529	IP65
UL 50 / UL 50E	Type 12
Ambient temperature limits	-40 °C ... +90 °C
Mechanical life (cycles)	≥ 500

CE UK
CA



CEC DNV
C/ALUS ECBT2.E115072 | ECBT8.E115072

Item	Description	Part No.	Entry	Dimension
	Hoods, 4 pegs, side entry, high construction, without gasket	TMAO 24.32 TMAO 24.40	M32 M40	
	Hoods, 4 pegs, top entry, high construction, without gasket	TMAV 24.32 TMAV 24.40	M32 M40	

Inserts size 104.27	Poles	Pages	Inserts size 104.27	Poles	Pages	MIXO Modular Inserts	Pages
CNE	16 A	24 + ☉ B.41	CSS	16 A	24 + ☉ B.121	MIXO modules	C.12-93
CCE	16 A	24 + ☉ B.47	CMCE / CMSH	16 A	10 + 2 (aux.) + ☉ B.146,151	CX 06 T (6-slot sized MIXO frames)	C.95
CSH / JSH S	16 A	24 + ☉ B.55,61	CX	100 A/16 A	8/0 and 6/6 + ☉ B.156-157		
CSHT	16 A	24 + ☉ B.68	CX / CXC	80 A/16 A	4/8 + ☉ B.161-162		
CQE / CQEY	16 A	46 + ☉ B.75,85					
CQEE	16 A	64 + ☉ B.79					
CD	10 A	64 + ☉ B.91					
CDD	10 A	108 + ☉ B.97					
CDSH	10 A	42 + ☉ B.105					

Accessories:




CR BPE
PE jumpers
Page E.236

T-TYPE series – Insulating

size **44.27 – 104.27**

T-TYPE Covers for Heavy-Duty Applications
T-TYPE/W Covers for Aggressive Environments

Aggressive Environments 


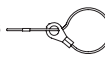
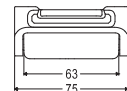

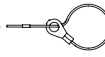
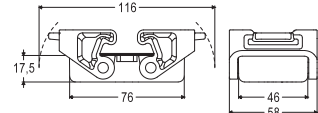


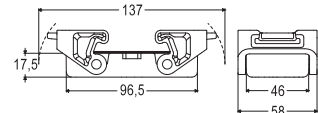

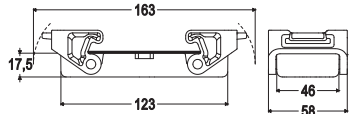
Heavy-Duty Applications 

EN 60529	T-TYPE: IP65 T-TYPE/W: IP65 / IP66 / IP69
UL 50 / UL 50E	T-TYPE: Type 12 T-TYPE/W: Type 12 – Type 4 / 4X Indoor Use Only
Ambient temperature limits	-40 °C ... +90 °C
Mechanical life (cycles)	≥ 500

CE UK CA

 (pending: CQC)

 ECBT2.E115072 | ECBT8.E115072

Item	Description	T-TYPE	T-TYPE/W	Entry	Dimension
	Covers, 1 lever and gasket - PUR gasket for T-TYPE - FKM gasket for T-TYPE/W For enclosures with 2 pegs without gasket with loop for hoods 	TCHC 06 LG	THCW 06 LG		
	Covers, 2 levers and gasket - PUR gasket for T-TYPE - FKM gasket for T-TYPE/W For enclosures with 4 pegs without gasket with loop for hoods 	TCHC 10 G	THCW 10 G		
	Covers, 2 levers and gasket - PUR gasket for T-TYPE - FKM gasket for T-TYPE/W For enclosures with 4 pegs without gasket with loop for hoods 	TCHC 16 G	THCW 16 G		
	Covers, 2 levers and gasket - PUR gasket for T-TYPE - FKM gasket for T-TYPE/W For enclosures with 4 pegs without gasket with loop for hoods 	TCHC 24 G	THCW 24 G		

T-TYPE and T-TYPE/W

E

T-TYPE series – Insulating

Covers – 2 or 4 pegs

size **44.27 – 104.27**

Aggressive
Environments



Heavy-Duty
Applications



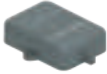


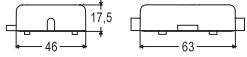



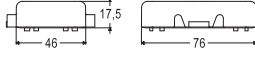
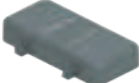
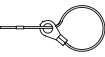

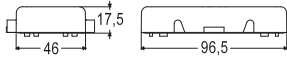
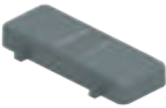

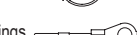
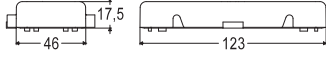
EN 60529	IP65
UL 50 / UL 50E	Type 12
Ambient temperature limits	-40 °C ... +90 °C
Mechanical life (cycles)	≥ 500



CE UK
CA




ECBT2.E115072 | ECBT8.E115072

Item	Description	With loop	With eyelet	Entry	Dimension
	Covers, 2 pegs, without gasket For enclosures with 1 lever and gasket with loop for hoods  or with eyelet for housings 	TCHC 06 SL	TCHC 06 L		
	Covers, 4 pegs, without gasket For enclosures with 2 levers and gasket with loop for hoods  or with eyelet for housings 	TCHC 10 S	TCHC 10		
	Covers, 4 pegs, without gasket For enclosures with 2 levers and gasket with loop for hoods  or with eyelet for housings 	TCHC 16 S	TCHC 16		
	Covers, 4 pegs, without gasket For enclosures with 2 levers and gasket with loop for hoods  or with eyelet for housings 	TCHC 24 S	TCHC 24		

T-TYPE series – Insulating Accessories

size **44.27 – 104.27**



Aggressive Environments 

Heavy-Duty Applications 

CE UK CA

DNV  

CAIUS[®] ECBT2.E115072 | ECBT8.E115072

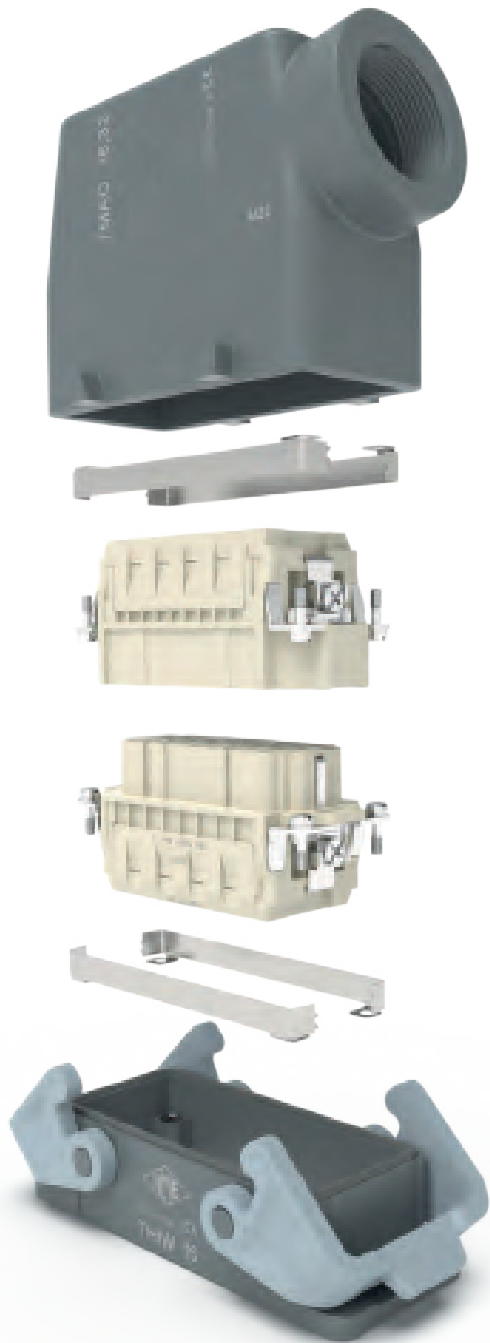
Item	Description	Size	Part No.	Dimension
	<p>PE jumpers in galvanized brass, to be optionally used with T-TYPE enclosures series</p> <p>CR...BPE accessories PE jumpers could be mounted under the connector inserts to guarantee proper PE connection.</p> <p>The jumpers are not usable individually. It is necessary to use <u>both</u> supplied jumpers (in the same housing or hood) in order to ensure the proper inserts alignment.</p>	44.27	CR 06 BPE	
		57.27	CR 10 BPE	
		77.27	CR 16 BPE	
		104.27	CR 24 BPE	

T-TYPE and T-TYPE/W

E

Materials

Pe jumpers galvanized brass



Panel cut-out drawings

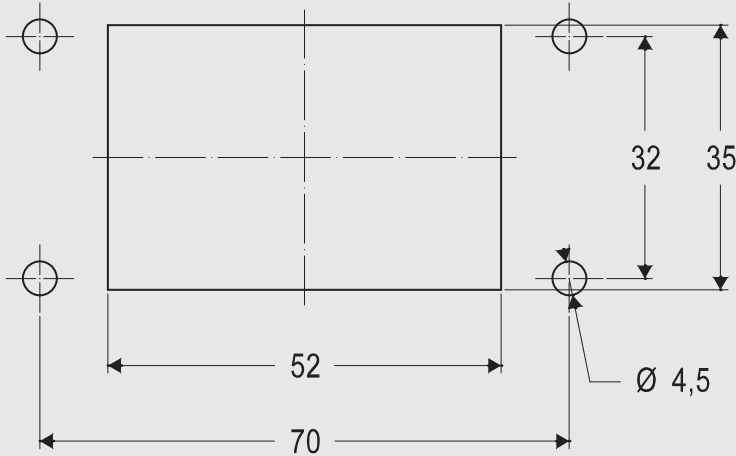
For T-TYPE series bulkhead mounting housings

To guarantee the declared IP degree of protection of the housings reported in this catalogue, according to EN IEC 60529 or to the relevant Type rating per ANSI/UL 50 and 50E (for those products bearing approval to those ratings), the surface of the mounting panel must meet the following requirements (definitions are provided in ISO 4287 standard):

- Waviness** $Wt \leq 0,2$ mm over a distance of 200 mm (measured on the panel without load)
- Roughness** $Ra \leq 16$ μ m

Scale 1:1

Size 44.27



Required screws: 4
Screws size: M4
Recommended torque:
 0,8 – 1,2 Nm / 7.1 – 10.6 lb.in

Size 57.27



Required screws: 4
Screws size: M4
Recommended torque:
 0,8 – 1,2 Nm / 7.1 – 10.6 lb.in

Notes: The values of tightening torque indicated above are just recommended values, that must be related – by the designer of the final application – to the resistance class of the screws (not included), with the assumption that the mounting panel is sufficiently rigid (stiff). If the deflection of the panel, under the effect of tightening the screws, is greater than 0,7 mm over a distance of 100 mm, it is

necessary to use the counter-flanges mentioned in our catalogue or the special flange gaskets available upon request (please contact our Sales Department).

Panel cut-out drawings

For T-TYPE series bulkhead mounting housings

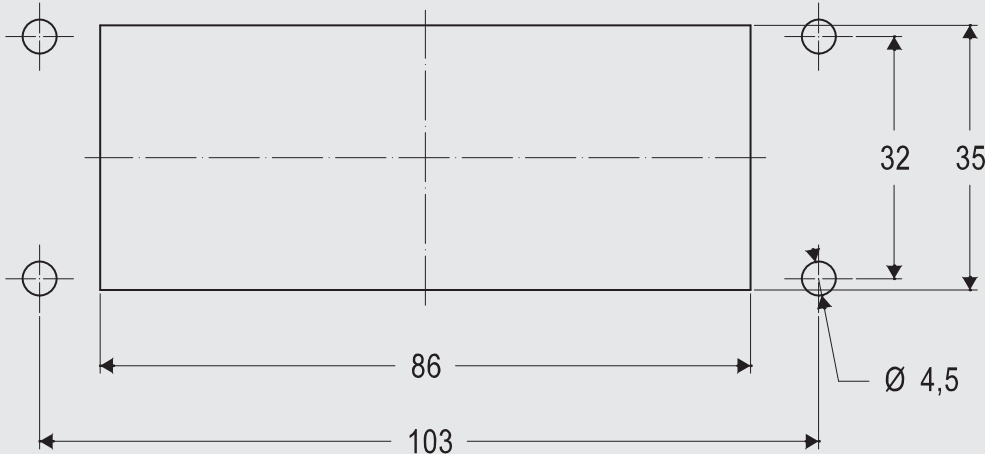
To guarantee the declared IP degree of protection of the housings reported in this catalogue, according to EN IEC 60529 or to the relevant Type rating per ANSI/UL 50 and 50E (for those products bearing approval to those ratings), the surface of the mounting panel must meet the following requirements (definitions are provided in ISO 4287 standard):

Waviness $W_t \leq 0,2$ mm over a distance of 200 mm
(measured on the panel without load)

Roughness $R_a \leq 16$ μm

Scale 1:1

Size 77.27



Required screws: 4
Screws size: M4
Recommended torque:
0,8 – 1,2 Nm / 7.1 – 10.6 lb.in

Size 104.27



Required screws: 4
Screws size: M4
Recommended torque:
0,8 – 1,2 Nm / 7.1 – 10.6 lb.in

Notes: The values of tightening torque indicated above are just recommended values, that must be related – by the designer of the final application – to the resistance class of the screws (not included), with the assumption that the mounting panel is sufficiently rigid (stiff). If the deflection of the panel, under the effect of tightening the screws, is greater than 0,7 mm over a distance of 100 mm, it is

necessary to use the counter-flanges mentioned in our catalogue or the special flange gaskets available upon request (please contact our Sales Department).



T-TYPE/H and T-TYPE/C HYGIENIC series



T-TYPE/H and T-TYPE/C

Enclosures for food and beverage requirements

The Hygienic multi-pole connector enclosures version (series T-TYPE/H and T-TYPE/C) has been designed for installation on food industry machines and equipment.

Based upon the standard T-TYPE enclosure series, materials have been selected to comply with the requirements laid down by chapter 2.1 of Machinery Directive 2006/42/EC for accidental contact with food products and compatible with the cleaning and sanitising agents typically used in the food industry.

Based on the requirements outlined in EHEDG Guideline n. 32 "Materials of construction for food equipment in contact with food" (EHEDG = European Hygienic Engineering & Design Group), the closing levers and sealing gaskets are made of metal-detectable thermoplastic blue-coloured material to quickly identify accidental contaminations in food products and facilitate the visual identification of their complete cleanliness.



Watch our clip

❖ Markings and Approvals

- CE and UKCA markings, EAC not applicable
- UL certified for USA and Canada for Type 12 – Type 4 / 4X Indoor Use Only degrees of protection (enclosure type ratings, equivalent to NEMA rating)
- IP65 / IP66 / IP69 degree of protection.
- RoHS: compliant



ECOLAB
PROTECTING WHAT'S VITAL™

SUM-UP

T-TYPE/H series

PRODUCTION LINES APPLICATIONS

- > Enclosures in thermoplastic material, dark grey RAL 7012 colour, with high thicknesses providing structural solidity and durability
- > Sealing gaskets made by HNBR rubber formulated in accordance with FDA Guideline 21 CFR §177.2600
- > Locking levers in metal detectable thermoplastic material, blue colour
- > M25, M32 and M40 threaded cable entries
- > IP65 / IP66 / IP69 degree of protection according to EN 60529
- > Each enclosure carries its own part number, thread/size and conformity markings
- > Ambient temperature range: -40 °C / +70 °C



T-TYPE/C series

LOW TEMPERATURE APPLICATIONS

- > Enclosures in thermoplastic material, dark grey RAL 7012
- > The Hygienic T-TYPE/C series enclosures have been specifically designed for food and beverage ambient temperature as low as -50 °C (range: -50 °C / +70 °C)
- > Enclosures in thermoplastic material, dark grey RAL 7012 colour, with high thicknesses providing structural solidity and durability
- > IP65 / IP66 / IP69 degree of protection according to EN 60529
- > This version differs from the Hygienic T-TYPE/H one for the sealing gaskets made by in accordance with FDA Guideline 21 CFR §177.2600
- > ILME T-TYPE/C series enclosure materials have been selected according to EU n. 10/2011 regulation requirements and each component has been tested according to EU regulation n. 10/2011 and EC regulation n. 1935/2004

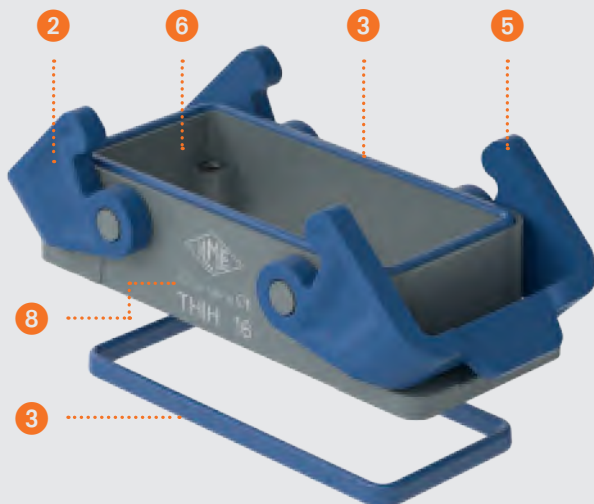


NOTE:

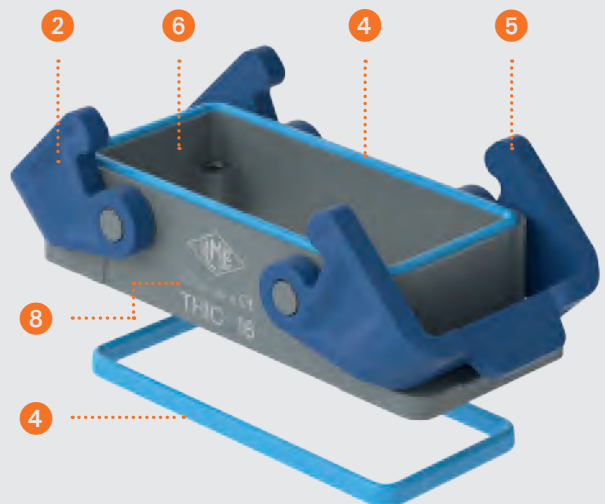
As the characterizing elements of the Hygienic series are the different sealing gasket material and the different locking lever, hoods and covers without sealing gaskets and locking levers are the same of series T-TYPE Standard. See page E.228.

T-TYPE/H and T-TYPE/C HYGIENIC series

TECHNICAL FEATURES



T-TYPE/H series
PRODUCTION LINES APPLICATIONS



T-TYPE/C series
LOW TEMPERATURE APPLICATIONS

- 1 **Construction:** Structurally solid and mechanically robust, built using BC-MUL® moulding technique together with the use of MIL.BOX® UL 94V-2 material. T-TYPE series is particularly resistant to the main pollutants present in industrial environments.
- 2 **Hygienic Design:** Smooth designed surfaces for levers and enclosure bodies to prevent the dirt retaining.
- 3 **T-TYPE/H gaskets:** Gaskets for T-TYPE/H have been produced in **HNBR rubber** and have been incorporated in the base flange on bulkhead mounting housings for easier installation formulated in accordance with FDA Guideline 21 CFR §177.2600.
- 4 **T-TYPE/C gaskets:** Gaskets for T-TYPE/C have been produced in **SILICONE rubber** and have been incorporated in the base flange on bulkhead mounting housings for easier installation formulated in accordance with FDA Guideline 21 CFR §177.2600.
- 5 **Levers:** The locking levers have been produced in self-extinguishing metal detectable thermoplastic material, blue colour. In accordance with the requirements set forth in EHEDG Guideline n. 32 “Materials of construction for food equipment in contact with food” (EHEDG = European Hygienic Engineering & Design Group), the closing levers and sealing gaskets are coloured blue to easily identify any accidental contaminations in food products and to facilitate the visual identification of their complete cleanliness.
- 6 **Dimensions:** The internal dimensions allow mounting of all connector inserts in their relevant sizes. The external dimensions of the bulkhead mounting housings are similar to those of the corresponding metallic enclosures (standard panel cut-outs and fixing holes). Hoods offer an inner cabling space similar to the “high” construction models of the corresponding metal enclosures. Other characteristics comply with the applicable safety standard for electrical connectors, IEC/EN 61984.
- 7 **Cable entries:** The housing and hood cable entries are available with metric thread, respectively:
 - **M25 or M32** for smaller sizes 44.27 and 57.27
 - **M32 or M40** for larger sizes 77.27 and 104.27
- 8 **Markings:** Each enclosure carries its own part number and conformity markings.
- 9 **Housings:** As the characterizing elements of the Hygienic series are the different sealing gasket material and the different locking lever, hoods and covers without sealing gaskets and locking levers are the same of series T-TYPE Standard.

ACCESSORIES

Planarity gaskets for T-TYPE Hygienic mounting housings

Suitable for closing the gap underneath wall-mounting housings of all sizes 44.27, 57.27, 77.27 and 104.27 of the T-TYPE HYGIENIC (both /H and /C for cold applications).

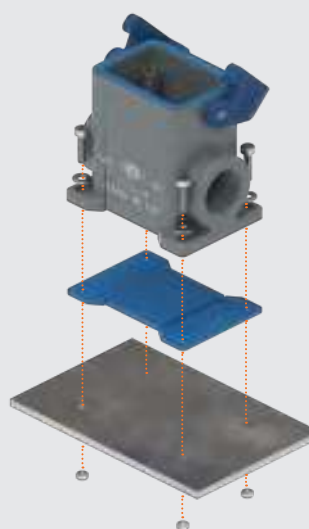
Re-establish planarity of the bottom (base) of these housings, thus avoiding the potential “nesting” of hazardous dirt in a gap that would otherwise be difficult to fully clean with washing in HYGIENIC applications. Made with food grade silicone rubber, blue coloured.



PE Jumpers

For T-TYPE/H and T-TYPE/C, enclosure versions with pre-installed PE jumpers (also known as “bridges,” hence the suffix B to identify such variants) are available upon request.


Example: THIH 06 LB is the enclosure version with pre-installed PE jumpers of the standard THIH 06 L.



T-TYPE Hygienic series – Food and Beverage

size **44.27**

T-TYPE/H Housings and hoods for production lines
T-TYPE/C Housings and hoods for low-temperatures


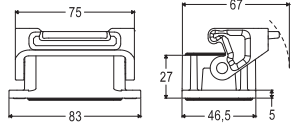

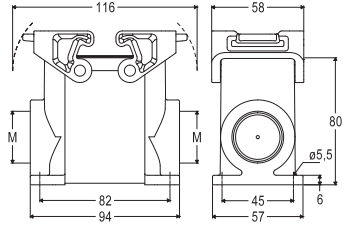

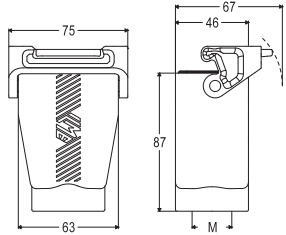
Specialized Applications 

EN 60529	IP65 / IP66 / IP69
UL 50 / UL 50E	Type 12 – Type 4 / 4X Indoor Use Only
Ambient temperature limits	T-TYPE/H: -40 °C ... +70 °C T-TYPE/C: -50 °C ... +70 °C
Mechanical life (cycles)	≥ 500

CE UK

 (pending: CQC)

 ECBT2.E115072 | ECBT8.E115072

Item	Description	T-TYPE/H	T-TYPE/C	Entry	Dimension
	Bulkhead mounting housings, 1 lever - HNBR gasket for T-TYPE/H - SILICONE gasket for T-TYPE/C	THIH 06 L	THIC 06 L		
	Surface mounting housings, 1 lever, high construction - HNBR gasket for T-TYPE/H - SILICONE gasket for T-TYPE/C Supplied with an open threaded entry and diametrically opposite a closed threaded entry which can be opened by the user if required (with suitable tool).	TAPH 06 L25 TAPH 06 L32	TAPC 06 L25 TAPC 06 L32	M25 M32	
	Hoods, 1 lever and gasket, top entry, high construction - HNBR gasket for T-TYPE/H - SILICONE gasket for T-TYPE/C	TAVH 06 LG25 TAVH 06 LG32	TAVC 06 LG25 TAVC 06 LG32	M25 M32	

T-TYPE/H and T-TYPE/C

E

Inserts size 44.27	Poles	Pages	MIXO Modular Inserts	Pages
CNE	16 A	6 + ⊕	B.38	C.12-93
CCE	16 A	6 + ⊕	B.44	C.95
CSH / JSH S	16 A	6 + ⊕	B.52,58	
CQE / CQEY	16 A	10 + ⊕	B.72,82	
CDD	10 A	24 + ⊕	B.94	
CDSH / CDSH NC	10 A	9 and 6 + ⊕	B.102,108	
CSS	16 A	6 + ⊕	B.118	

Complete with:



Hoods
Page E.227



Covers
Page E.235



PE jumpers
(Optional)
Page E.249

T-TYPE Hygienic series – Food and Beverage

size **57.27**

T-TYPE/H Housings and hoods for production lines

T-TYPE/C Housings and hoods for low-temperatures


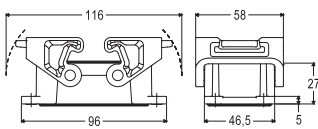

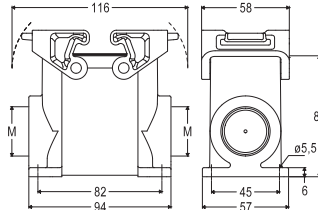

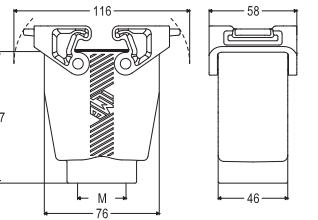
Specialized
Applications

CE UK

EN 60529	IP65 / IP66 / IP69
UL 50 / UL 50E	Type 12 – Type 4 / 4X Indoor Use Only
Ambient temperature limits	T-TYPE/H: -40 °C ... +70 °C T-TYPE/C: -50 °C ... +70 °C
Mechanical life (cycles)	≥ 500

(pending: CQC)

ECBT2.E115072 | ECBT8.E115072

Item	Description	T-TYPE/H	T-TYPE/C	Entry	Dimension
	Bulkhead mounting housings, 2 levers - HNBR gasket for T-TYPE/H - SILICONE gasket for T-TYPE/C	THIH 10	THIC 10		
	Surface mounting housings, 2 levers, high construction - HNBR gasket for T-TYPE/H - SILICONE gasket for T-TYPE/C Supplied with an open threaded entry and diametrically opposite a closed threaded entry which can be opened by the user if required (with suitable tool).	TAPH 10.25 TAPH 10.32	TAPC 10.25 TAPC 10.32	M25 M32	
	Hoods, 2 levers and gasket, top entry, high construction - HNBR gasket for T-TYPE/H - SILICONE gasket for T-TYPE/C	TAVH 10 G25 TAVH 10 G32	TAVC 10 G25 TAVC 10 G32	M25 M32	

T-TYPE/H and T-TYPE/C

E

Inserts size 57.27	Poles	Pages	Inserts size 57.27	Poles	Pages		
CNE	16 A	10 + ☉	B.39	CMCE / CMSH	16 A	3 + 2 (aux.) + ☉	B.144,149
CCE	16 A	10 + ☉	B.45	CX	40 A/10 A	8/24 + ☉	B.170-171
CSH / JSH S	16 A	10 + ☉	B.53,59				
CSHT	16 A	10 + ☉	B.66				
CQE / CQEY	16 A	18 + ☉	B.73,83				
CDD	10 A	42 + ☉	B.95	MIXO Modular Inserts		Pages	
CDSH	10 A	18 + ☉	B.103	MIXO modules		C.12-93	
CSS	16 A	10 + ☉	B.119	CX 03 T (3-slot sized MIXO frames)		C.95	

Complete with:


Hoods
Page E.229


Covers
Page E.235

PE jumpers
(Optional)
Page E.249

T-TYPE Hygienic series – Food and Beverage

size **77.27**


T-TYPE/H Housings and hoods for production lines
T-TYPE/C Housings and hoods for low-temperatures


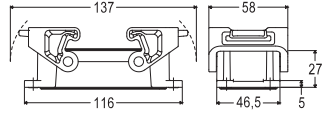

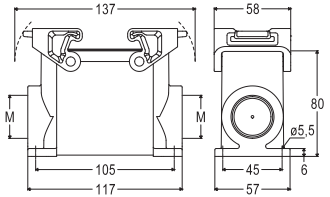

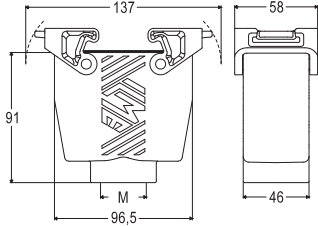
Specialized Applications 

EN 60529	IP65 / IP66 / IP69
UL 50 / UL 50E	Type 12 – Type 4 / 4X Indoor Use Only
Ambient temperature limits	T-TYPE/H: -40 °C ... +70 °C T-TYPE/C: -50 °C ... +70 °C
Mechanical life (cycles)	≥ 500

CE UK

 (pending: CQC)

 ECBT2.E115072 | ECBT8.E115072

Item	Description	T-TYPE/H	T-TYPE/C	Entry	Dimension
	Bulkhead mounting housings, 2 levers - HNBR gasket for T-TYPE/H - SILICONE gasket for T-TYPE/C	THIH 16	THIC 16		
	Surface mounting housings, 2 levers, high construction - HNBR gasket for T-TYPE/H - SILICONE gasket for T-TYPE/C Supplied with an open threaded entry and diametrically opposite a closed threaded entry which can be opened by the user if required (with suitable tool).	TAPH 16.32 TAPH 16.40	TAPC 16.32 TAPC 16.40	M32 M40	
	Hoods, 2 levers and gasket, top entry, high construction - HNBR gasket for T-TYPE/H - SILICONE gasket for T-TYPE/C	TAVH 16 G32 TAVH 16 G40	TAVC 16 G32 TAVC 16 G40	M32 M40	

T-TYPE/H and T-TYPE/C

E

Inserts size 77.27	Poles	Pages	Inserts size 77.27	Poles	Pages	MIXO Modular Inserts	Pages
CNE	16 A	16 + ☉ B.40	CP / CPY	35 A	6 + ☉ B.112,114	MIXO modules	C.12-93
CCE	16 A	16 + ☉ B.46	CSS	16 A	16 + ☉ B.120	CX 04 T (4-slot sized MIXO frames)	C.95
CSH / JSH S	16 A	16 + ☉ B.54,60	CMCE / CMSH	16 A	6 + 2 (aux.) + ☉ B.145,150		
CSHT	16 A	16 + ☉ B.67	CX / CXC	80 A/16 A	4/0, 4/2 + ☉ B.158-160		
CQE / CQEY	16 A	32 + ☉ B.74,84	CX	40 A/10 A	6/12, 6/36, 9/42 and 12/2 + ☉ B.163-164, 168-169		
CQEE	16 A	40 + ☉ B.78					
CD	10 A	40 + ☉ B.90					
CDD	10 A	72 + ☉ B.94					
CDSH	10 A	27 + ☉ B.104					

Complete with:



Hoods
Page E.231



Covers
Page E.235



PE jumpers
(Optional)
Page E.249

T-TYPE Hygienic series – Food and Beverage

size **104.27**

T-TYPE/H Housings and hoods for production lines

T-TYPE/C Housings and hoods for low-temperatures

Specialized
Applications

EN 60529	IP65 / IP66 / IP69
UL 50 / UL 50E	Type 12 – Type 4 / 4X Indoor Use Only
Ambient temperature limits	T-TYPE/H: -40 °C ... +70 °C T-TYPE/C: -50 °C ... +70 °C
Mechanical life (cycles)	≥ 500

CE UK

(pending: CQC)

ECBT2.E115072 | ECBT8.E115072

Item	Description	T-TYPE/H	T-TYPE/C	Entry	Dimension
	Bulkhead mounting housings, 2 levers - HNBR gasket for T-TYPE/H - SILICONE gasket for T-TYPE/C	THIH 24	THIC 24		
	Surface mounting housings, 2 levers, high construction - HNBR gasket for T-TYPE/H - SILICONE gasket for T-TYPE/C Supplied with an open threaded entry and diametrically opposite a closed threaded entry which can be opened by the user if required (with suitable tool).	TAPH 24.32 TAPH 24.40	TAPC 24.32 TAPC 24.40	M32 M40	
	Hoods, 2 levers and gasket, top entry, high construction - HNBR gasket for T-TYPE/H - SILICONE gasket for T-TYPE/C	TAVH 24 G32 TAVH 24 G40	TAVC 24 G32 TAVC 24 G40	M32 M40	

T-TYPE/H and T-TYPE/C

E

Inserts size 104.27	Poles	Pages	Inserts size 104.27	Poles	Pages	MIXO Modular Inserts	Pages		
CNE	16 A	24 + ☉	B.41	CSS	16 A	24 + ☉	B.121	MIXO modules	C.12-93
CCE	16 A	24 + ☉	B.47	CMCE / CMSH	16 A	10 + 2 (aux.) + ☉	B.146,151	CX 06 T (6-slot sized MIXO frames)	C.95
CSH / JSH S	16 A	24 + ☉	B.55,61	CX	100 A/16 A	8/0 and 6/6 + ☉	B.156-157		
CSHT	16 A	24 + ☉	B.68	CX / CXC	80 A/16 A	4/8 + ☉	B.161-162		
CQE / CQEY	16 A	46 + ☉	B.75,85					Complete with:	
CQEE	16 A	64 + ☉	B.79					Hoods	Page E.233
CD	10 A	64 + ☉	B.91					Covers	Page E.235
CDD	10 A	108 + ☉	B.97					PE jumpers	(Optional) Page E.249
CDSH	10 A	42 + ☉	B.105						

dimensions shown in mm are not binding and may be changed without notice

E.247

T-TYPE Hygienic series – Food and Beverage

size **44.27 – 104.27**


T-TYPE/H Covers for production lines
T-TYPE/C Covers for low-temperatures


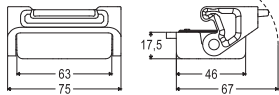
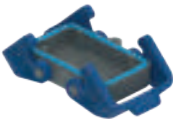

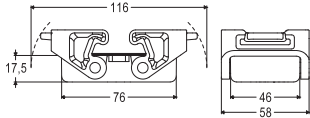


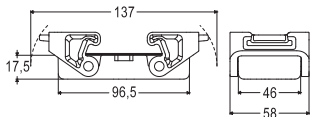


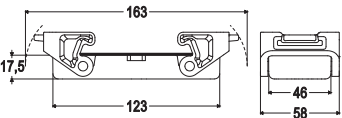
Specialized Applications 

EN 60529	IP65 / IP66 / IP69
UL 50 / UL 50E	Type 12 – Type 4 / 4X Indoor Use Only
Ambient temperature limits	T-TYPE/H: -40 °C ... +70 °C T-TYPE/C: -50 °C ... +70 °C
Mechanical life (cycles)	≥ 500

CE UK CA

 (pending: CQC)

 ECBT2.E115072 | ECBT8.E115072

Item	Description	T-TYPE/H	T-TYPE/C	Size	Dimension
	Covers, 1 lever and gasket - HNBR gasket for T-TYPE/H - SILICONE gasket for T-TYPE/C For enclosures with 2 pegs without gasket with loop for hoods 	THCH 06 LG	THCC 06 LG	44.27	
	Covers, 2 levers and gasket - HNBR gasket for T-TYPE/H - SILICONE gasket for T-TYPE/C For enclosures with 4 pegs without gasket with loop for hoods 	THCH 10 G	THCC 10 G	57.27	
	Covers, 2 levers and gasket - HNBR gasket for T-TYPE/H - SILICONE gasket for T-TYPE/C For enclosures with 4 pegs without gasket with loop for hoods 	THCH 16 G	THCC 16 G	77.27	
	Covers, 2 levers and gasket - HNBR gasket for T-TYPE/H - SILICONE gasket for T-TYPE/C For enclosures with 4 pegs without gasket with loop for hoods 	THCH 24 G	THCC 24 G	104.27	

T-TYPE/H and T-TYPE/C

E

Complete with:



Hoods
Page E.227,229,231,233

T-TYPE Hygienic series – Food and Beverage


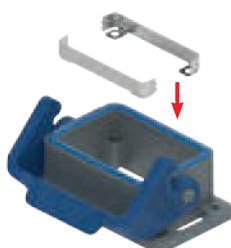




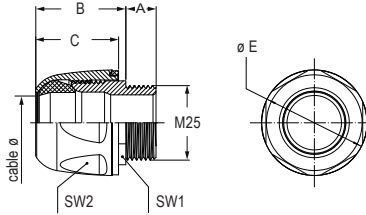




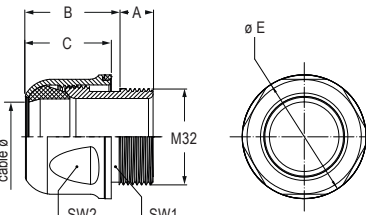

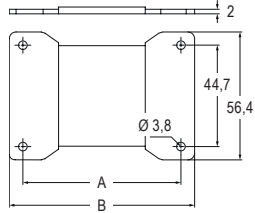
size 44.27 – 104.27

Accessories

Specialized
Applications

CE UK

cRU[®] US ECBT2.E115072 | ECBT8.E115072

Item	Description	Size	Part No.	Entry	Dimension
	PE jumpers in galvanized brass, to be optionally used with T-TYPE enclosures series CR...BPE accessories PE jumpers could be mounted under the connector inserts to guarantee proper PE connection. The jumpers are not usable individually. It is necessary to use both supplied jumpers (in the same housing or hood) in order to ensure the proper inserts alignment.	44.27 57.27 77.27 104.27	CR 06 BPE CR 10 BPE CR 16 BPE CR 24 BPE		
	Hygienic cable glands M25X1,5 for T-TYPE/H and T-TYPE/C enclosures - IP68, IP69 degree of protection - Ambient temperature limit: -20 °C ... +85 °C - ECOLAB and EHEDG compliant cRU [®] US    certified	ø 12,0-15,0 ø 15,0-18,0	AH M25IF AH M25IFL	M25 M25	 Part No. A B C SW1 SW2 ø E cable ø AH M25IF 10 30 27 24 38 34,9 12-15 AH M25IFL 10 30 27 24 38 34,9 15-18
	Hygienic cable glands M32X1,5 for T-TYPE/H and T-TYPE/C enclosures - IP68, IP69 degree of protection - Ambient temperature limit: -20 °C ... +85 °C - ECOLAB and EHEDG compliant cRU [®] US    certified	ø 18,0-21,0 ø 20,0-23,0	AH M32IF AH M32IFL	M32 M32	 Part No. A B C SW1 SW2 ø E cable ø AH M32IF 11 32 28 30 38 40,9 18-21 AH M32IFL 11 32 28 30 38 40,9 20-23
	Planarity gasket for T-TYPE HYGIENIC surface mounting housings	44.27 57.27 77.27 104.27	CR 06 GTPC CR 10 GTPC CR 16 GTPC CR 24 GTPC		 Part No. polarity A (mm) B (mm) CR 06 GTPC 06 69,7 81,7 CR 10 GTPC 10 81,7 93,9 CR 16 GTPC 16 104,7 116,7 CR 24 GTPC 24 131,7 143,6

Materials

Cable glands	thermoplastic
Pe jumpers	galvanized brass
Planarity gasket	food grade silicone

Colours

Cable glands	white, blue, RAL 5005
Planarity gasket	blue, RAL 5005

Panel cut-out drawings

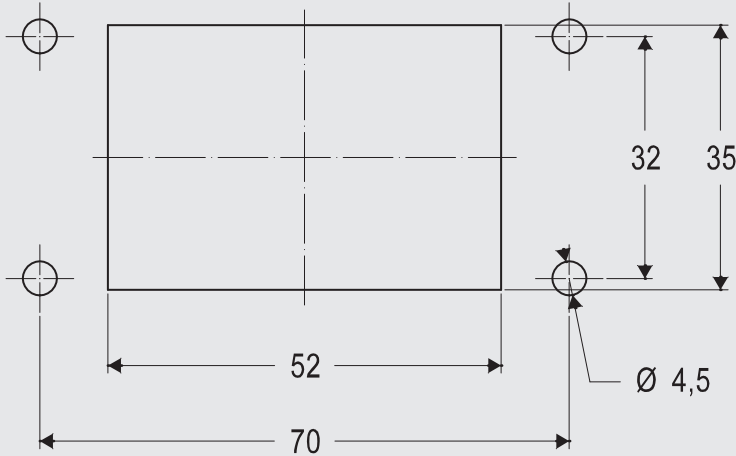
For T-TYPE Hygienic series bulkhead mounting housings

To guarantee the declared IP degree of protection of the housings reported in this catalogue, according to EN IEC 60529 or to the relevant Type rating per ANSI/UL 50 and 50E (for those products bearing approval to those ratings), the surface of the mounting panel must meet the following requirements (definitions are provided in ISO 4287 standard):

- Waviness** Wt ≤ 0,2 mm over a distance of 200 mm (measured on the panel without load)
- Roughness** Ra ≤ 16 µm

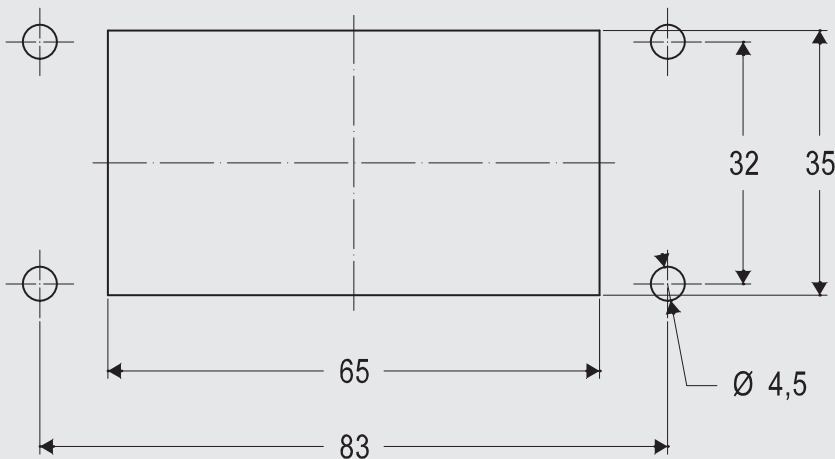
Scale 1:1

Size 44.27



Required screws: 4
Screws size: M4
Recommended torque:
 0,8 – 1,2 Nm / 7.1 – 10.6 lb.in

Size 57.27



Required screws: 4
Screws size: M4
Recommended torque:
 0,8 – 1,2 Nm / 7.1 – 10.6 lb.in

Notes: The values of tightening torque indicated above are just recommended values, that must be related – by the designer of the final application – to the resistance class of the screws (not included), with the assumption that the mounting panel is sufficiently rigid (stiff). If the deflection of the panel, under the effect of tightening the screws, is greater than 0,7 mm over a distance of 100 mm, it is

necessary to use the counter-flanges mentioned in our catalogue or the special flange gaskets available upon request (please contact our Sales Department).

Panel cut-out drawings

For T-TYPE Hygienic series bulkhead mounting housings

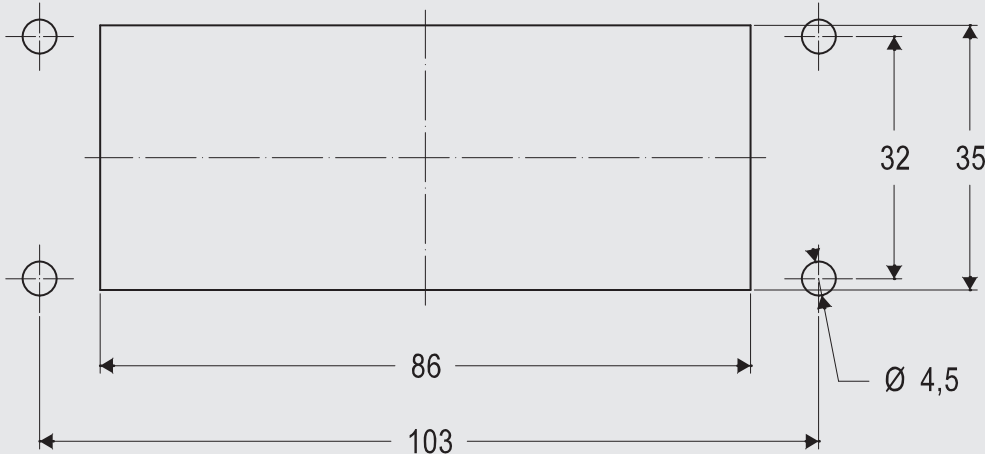
To guarantee the declared IP degree of protection of the housings reported in this catalogue, according to EN IEC 60529 or to the relevant Type rating per ANSI/UL 50 and 50E (for those products bearing approval to those ratings), the surface of the mounting panel must meet the following requirements (definitions are provided in ISO 4287 standard):

Waviness $Wt \leq 0,2$ mm over a distance of 200 mm
(measured on the panel without load)

Roughness $Ra \leq 16$ μm

Scale 1:1

Size 77.27



Required screws: 4
Screws size: M4
Recommended torque:
0,8 – 1,2 Nm / 7.1 – 10.6 lb.in

Size 104.27



Required screws: 4
Screws size: M4
Recommended torque:
0,8 – 1,2 Nm / 7.1 – 10.6 lb.in

Notes: The values of tightening torque indicated above are just recommended values, that must be related – by the designer of the final application – to the resistance class of the screws (not included), with the assumption that the mounting panel is sufficiently rigid (stiff). If the deflection of the panel, under the effect of tightening the screws, is greater than 0,7 mm over a distance of 100 mm, it is

necessary to use the counter-flanges mentioned in our catalogue or the special flange gaskets available upon request (please contact our Sales Department).



CENTRAL LEVER series

Easy access for robotics



The series is specifically designed for industrial applications with limited installation space. Central Lever enclosures can be installed, placed side-by-side, and opened with a single movement.

SUM-UP

- > Made of die cast aluminium alloy, epoxy-polyester thermosetting powder coating grey RAL 7040.
- > Gaskets in anti-aging, oil-resistant, grease-resistant and fuel resistant vinyl nitrile elastomer.
- > Stainless steel locking device.
- > Ambient temperature range: -40 °C / +125 °C.
- > Stainless steel locking pegs with rollers, to reduce wear.

✔ Markings and Approvals

- CE and UKA markings, EAC not applicable
- UL certified for USA and Canada for Type 12, 4 and 4X degrees of protection (enclosure type ratings, equivalent to NEMA rating)
- IP65 degree of protection.
- RoHS: compliant



FOCUS

The shape of the lever reduces the effort required to uncouple the inserts by acting on the rolling pegs in a pre-opening phase.

Levers and technology



ACCESSORIES

Central Lever Locking Devices

A stainless steel locking device can be easily placed on the side of a 104.27 central lever hood to lock the lever's opening movement in place, avoiding any unwanted and potentially hazardous accidental opening.



▶ CR YLK24




▶ CR YLK24 SL

Central lever series

Housings and hoods with 2 pegs for central levers


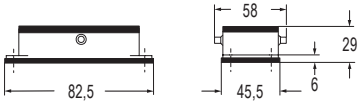

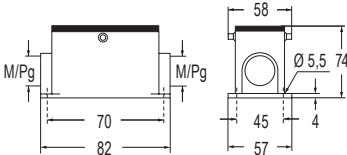

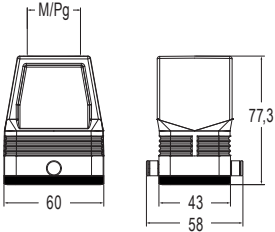
size **44.27**

Heavy-Duty Applications 

EN 60529	IP65
UL 50 / UL 50E	Type 12 / 4 / 4X
Ambient temperature limits	-40 °C ... +125 °C
Mechanical life (cycles)	≥ 500



CALUS ECBT2.E115072 | ECBT8.E115072

Item	Description	Part No.	Entry	Dimension
	Bulkhead mounting housings, 2 pegs and gasket	CHI 06 YC		
	Surface mounting housings, 2 pegs and gasket, high construction, 2 entries	MAP 06 YC232 CAP 06 YC229	M32 × 2 Pg 29 × 2	
	Hoods, top entry, 2 pegs and gasket, high construction To be used only with a complete cable gland	MFV 06 GYC25 MFV 06 GYC32 MFV 06 GYC40 CFV 06 GYC21 CFV 06 GYC29	M25 M32 M40 Pg 21 Pg 29	

CENTRAL LEVER


E

Inserts size 44.27	Poles	Pages	MIXO Modular Inserts	Pages
CNE	16 A 6 + ⊕	B.38	MIXO modules	C.12-93
CCE	16 A 6 + ⊕	B.44	CX 02 T (2-slot sized MIXO frames)	C.95
CSH / JSH S	16 A 6 + ⊕	B.52,58		
CQE / CQEY	16 A 10 + ⊕	B.72,82		
CDD	10 A 24 + ⊕	B.94		
CDSH / CDSH NC	10 A 9 and 6 + ⊕	B.102,108		
CSS	16 A 6 + ⊕	B.118		
CT / CTSE*	16 A 6 + ⊕	B.126,130		

*can be used only in bulkhead mounting housings


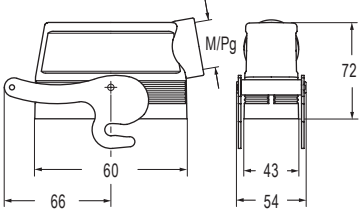

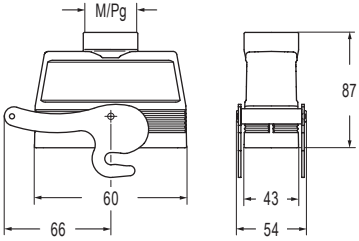
Central lever series

Hoods with central lever

size **44.27**
Heavy-Duty Applications

CE UK


EN 60529	IP65
UL 50 / UL 50E	Type 12 / 4 / 4X
Ambient temperature limits	-40 °C ... +125 °C
Mechanical life (cycles)	≥ 500

CAIUS ECBT2.E115072 | ECBT8.E115072


Item	Description	Part No.	Entry	Dimension
	Hoods, side entry, 1 central lever, without gasket	MAO 06 YX25 MAO 06 YX32 CAO 06 YX21 CAO 06 YX29	M25 M32 Pg 21 Pg 29	
	Hoods, top entry, 1 central lever, without gasket	MAV 06 YX25 MAV 06 YX32 CAV 06 YX21 CAV 06 YX29	M25 M32 Pg 21 Pg 29	

Inserts size 44.27	Poles	Pages	MIXO Modular Inserts	Pages
CNE	16 A 6 + ⊕	B.38	MIXO modules	C.12-93
CCE	16 A 6 + ⊕	B.44	CX 02 T (2-slot sized MIXO frames)	C.95
CSH / JSH S	16 A 6 + ⊕	B.52,58		
CQE / CQEY	16 A 10 + ⊕	B.72,82		
CDD	10 A 24 + ⊕	B.94		
CDSH / CDSH NC	10 A 9 and 6 + ⊕	B.102,108		
CSS	16 A 6 + ⊕	B.118		

Central lever series

Housings and hoods with 2 pegs for central levers

size **57.27**


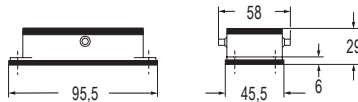

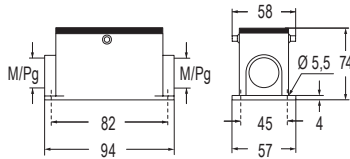

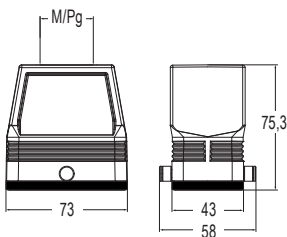
Heavy-Duty Applications 

CE UK CA

CEC DNV SIFITA

EN 60529	IP65
UL 50 / UL 50E	Type 12 / 4 / 4X
Ambient temperature limits	-40 °C ... +125 °C
Mechanical life (cycles)	≥ 500

CAIUS ECBT2.E115072 | ECBT8.E115072

Item	Description	Part No.	Entry	Dimension
	Bulkhead mounting housings, 2 pegs and gasket	CHI 10 YC		
	Surface mounting housings, 2 pegs and gasket, high construction, 2 entries	MAP 10 YC232 CAP 10 YC229	M32 × 2 Pg 29 × 2	
	Hoods, top entry, 2 pegs and gasket, high construction To be used only with a complete cable gland	MFV 10 GYC25 MFV 10 GYC32 MFV 10 GYC40 CFV 10 GYC21 CFV 10 GYC29	M25 M32 M40 Pg 21 Pg 29	

CENTRAL LEVER

E

Inserts size 57.27	Poles	Pages	Inserts size 57.27	Poles	Pages
CNE	16 A	10 + ☉ B.39	CT / CTSE*	16 A	10 + ☉ B.127,131
CCE	16 A	10 + ☉ B.45	CMCE / CMSH	16 A	3 + 2 (aux.) + ☉ B.144,149
CSH / JSH S	16 A	10 + ☉ B.53,59	CX	40 A/10 A	8/24 + ☉ B.170-171
CSHT	16 A	10 + ☉ B.66	*can be used only in bulkhead mounting housings		
CQE / CQEY	16 A	18 + ☉ B.73,83			
CDD	10 A	42 + ☉ B.95	MIXO Modular Inserts		
CDSH	10 A	18 + ☉ B.103	MIXO modules		
CSS	16 A	10 + ☉ B.119	CX 03 T (3-slot sized MIXO frames)		
					Pages
					C.12-93
					C.95


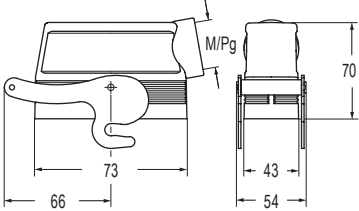

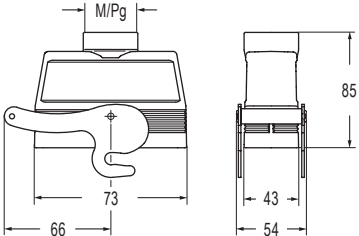
Central lever series

Hoods with central lever

size **57.27**
Heavy-Duty Applications
CE UK


EN 60529	IP65
UL 50 / UL 50E	Type 12 / 4 / 4X
Ambient temperature limits	-40 °C ... +125 °C
Mechanical life (cycles)	≥ 500

CAVUS ECBT2.E115072 | ECBT8.E115072


Item	Description	Part No.	Entry	Dimension
	Hoods, side entry, 1 central lever, without gasket	MAO 10 YX32 MAO 10 YX40 CAO 10 YX21 CAO 10 YX29	M32 M40 Pg 21 Pg 29	
	Hoods, top entry, 1 central lever, without gasket	MAV 10 YX32 MAV 10 YX40 CAV 10 YX21 CAV 10 YX29	M32 M40 Pg 21 Pg 29	

Inserts size 57.27	Poles	Pages	Inserts size 57.27	Poles	Pages		
CNE	16 A	10 + ☉	B.39	CMCE / CMSH	16 A	3 + 2 (aux.) + ☉	B.144,149
CCE	16 A	10 + ☉	B.45	CX	40 A/10 A	8/24 + ☉	B.170-171
CSH / JSH S	16 A	10 + ☉	B.53,59				
CSHT	16 A	10 + ☉	B.66				
CQE / CQEY	16 A	18 + ☉	B.73,83				
CDD	10 A	42 + ☉	B.95				
CDSH	10 A	18 + ☉	B.103				
CSS	16 A	10 + ☉	B.119				
				MIXO Modular Inserts		Pages	
				MIXO modules		C.12-93	
				CX 03 T (3-slot sized MIXO frames)		C.95	

Central lever series

Housings and hoods with 2 pegs for central levers


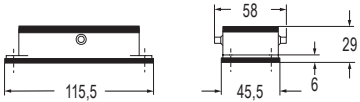

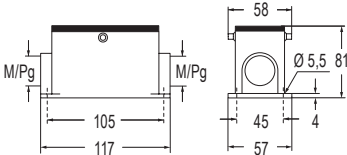

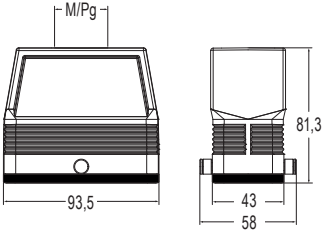
size **77.27**

Heavy-Duty Applications 

EN 60529	IP65
UL 50 / UL 50E	Type 12 / 4 / 4X
Ambient temperature limits	-40 °C ... +125 °C
Mechanical life (cycles)	≥ 500



CAIUS ECBT2.E115072 | ECBT8.E115072

Item	Description	Part No.	Entry	Dimension
	Bulkhead mounting housings, 2 pegs and gasket	CHI 16 YC		
	Surface mounting housings, 2 pegs and gasket, high construction, 2 entries	MAP 16 YC232 CAP 16 YC229	M32 × 2 Pg 29 × 2	
	Hoods, top entry, 2 pegs and gasket, high construction To be used only with a complete cable gland	MFV 16 GYC25 MFV 16 GYC32 MFV 16 GYC40 CFV 16 GYC21 CFV 16 GYC29	M25 M32 M40 Pg 21 Pg 29	

CENTRAL LEVER

E

Inserts size 77.27	Poles	Pages	Inserts size 77.27	Poles	Pages	MIXO Modular Inserts	Pages
CNE	16 A	16 + ☉ B.40	CP / CPY	35 A	6 + ☉ B.112,114	MIXO modules	C.12-93
CCE	16 A	16 + ☉ B.46	CSS	16 A	16 + ☉ B.120	CX 04 T (4-slot sized MIXO frames)	C.95
CSH / JSH S	16 A	16 + ☉ B.54,60	CT / CTSE*	16 A	16 + ☉ B.128,132		
CSHT	16 A	16 + ☉ B.67	CT / CTS*	10 A	40 + ☉ B.138,140		
CQE / CQEY	16 A	32 + ☉ B.74,84	CMCE / CMSH	16 A	6 + 2 (aux.) + ☉ B.145,150		
CQEE	16 A	40 + ☉ B.78	CX / CXC	80 A/16 A	4/0, 4/2 + ☉ B.158-160		
CD	10 A	40 + ☉ B.90	CX	40 A/10 A	6/12, 6/36, 9/42 and 12/2 + ☉ B.163-164, 168-169		
CDD	10 A	72 + ☉ B.94					
CDSH	10 A	27 + ☉ B.104					

*can be used only in bulkhead mounting housings

Central lever series

Hoods with central lever


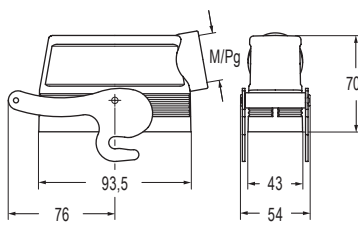

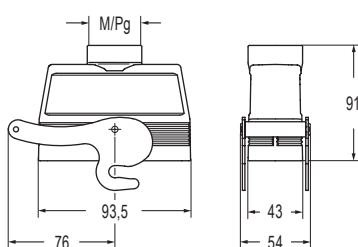
size **77.27**
Heavy-Duty Applications





EN 60529	IP65
UL 50 / UL 50E	Type 12 / 4 / 4X
Ambient temperature limits	-40 °C ... +125 °C
Mechanical life (cycles)	≥ 500

 ECBT2.E115072 | ECBT8.E115072


Item	Description	Part No.	Entry	Dimension
	Hoods, side entry, 1 central lever, without gasket	MAO 16 YX32 MAO 16 YX40 CAO 16 YX21 CAO 16 YX29	M32 M40 Pg 21 Pg 29	
	Hoods, top entry, 1 central lever, without gasket	MAV 16 YX32 MAV 16 YX40 CAV 16 YX21 CAV 16 YX29	M32 M40 Pg 21 Pg 29	

Inserts size 77.27	Poles	Pages	Inserts size 77.27	Poles	Pages	MIXO Modular Inserts	Pages	
CNE	16 A	16 + ☉ B.40	CP / CPY	35 A	6 + ☉	B.112,114	C.12-93	
CCE	16 A	16 + ☉ B.46	CSS	16 A	16 + ☉	B.120	CX 04 T (4-slot sized MIXO frames)	C.95
CSH / JSH S	16 A	16 + ☉ B.54,60	CMCE / CMSH	16 A	6 + 2 (aux.) + ☉	B.145,150		
CSHT	16 A	16 + ☉ B.67	CX / CXC	80 A/16 A	4/0, 4/2 + ☉	B.158-160		
CQE / CQEY	16 A	32 + ☉ B.74,84	CX	40 A/10 A	6/12, 6/36, 9/42 and 12/2 + ☉	B.163-164, 168-169		
CQEE	16 A	40 + ☉ B.78						
CD	10 A	40 + ☉ B.90						
CDD	10 A	72 + ☉ B.94						
CDSH	10 A	27 + ☉ B.104						

Central lever series

Housings and hoods with 2 pegs for central levers

size **104.27**


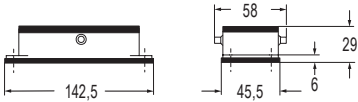

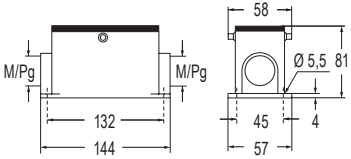

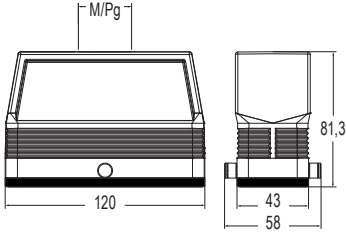
Heavy-Duty Applications 

CE UK CA

CEC DNV PRIMA

EN 60529	IP65
UL 50 / UL 50E	Type 12 / 4 / 4X
Ambient temperature limits	-40 °C ... +125 °C
Mechanical life (cycles)	≥ 500

CAUS ECBT2.E115072 | ECBT8.E115072

Item	Description	Part No.	Entry	Dimension
	Bulkhead mounting housings, 2 pegs and gasket	CHI 24 YC		
	Surface mounting housings, 2 pegs and gasket, high construction, 2 entries	MAP 24 YC232 CAP 24 YC229	M32 × 2 Pg 29 × 2	
	Hoods, top entry, 2 pegs and gasket, high construction To be used only with a complete cable gland	MFV 24 GYC25 MFV 24 GYC32 MFV 24 GYC40 CFV 24 GYC21 CFV 24 GYC29	M25 M32 M40 Pg 21 Pg 29	


CENTRAL LEVER

E

Inserts size 104.27	Poles	Pages	Inserts size 104.27	Poles	Pages	MIXO Modular Inserts	Pages	
CNE	16 A	24 + ☉ B.41	CSS	16 A	24 + ☉	B.121		
CCE	16 A	24 + ☉ B.47	CT / CTSE*	16 A	24 + ☉	B.129,133	C.12-93	
CSH / JSH S	16 A	24 + ☉ B.55,61	CT / CTS*	10 A	64 + ☉	B.139,141	CX 06 T (6-slot sized MIXO frames)	
CSHT	16 A	24 + ☉ B.68	CMCE / CMSH	16 A	10 + 2 (aux.) + ☉	B.146,151		
CQE / CQEY	16 A	46 + ☉ B.75,85	CX	100 A/16 A	8/0 and 6/6 + ☉	B.156-157		
CQEE	16 A	64 + ☉ B.79	CX / CXC	80 A/16 A	4/8 + ☉	B.161-162		
CD	10 A	64 + ☉ B.91	*can be used only in bulkhead mounting housings					
CDD	10 A	108 + ☉ B.97						
CDSH	10 A	42 + ☉ B.105						





Central lever series

Hoods with central lever

size **104.27**
Heavy-Duty Applications

CE UK


EN 60529	IP65
UL 50 / UL 50E	Type 12 / 4 / 4X
Ambient temperature limits	-40 °C ... +125 °C
Mechanical life (cycles)	≥ 500

ALUS ECBT2.E115072 | ECBT8.E115072

Item	Description	Part No.	Entry	Dimension
	Hoods, side entry, 1 central lever, without gasket	MAO 24 YX32 MAO 24 YX40 CAO 24 YX21 CAO 24 YX29	M32 M40 Pg 21 Pg 29	
	Hoods, top entry, 1 central lever, without gasket	MAV 24 YX32 MAV 24 YX40 CAV 24 YX21 CAV 24 YX29	M32 M40 Pg 21 Pg 29	
	Inclined hoods, side entry, 1 central lever, without gasket To be used only with a complete cable gland	MIO 24 YX40 MIO 24 YX50 CIO 24 YX36	M40 M50 Pg 36	
	Inclined hoods, top entry, 1 central lever, without gasket To be used only with a complete cable gland	MIV 24 YX40 MIV 24 YX50 CIV 24 YX36	M40 M50 Pg 36	

CENTRAL LEVER

E

Inserts size 104.27	Poles	Pages	Inserts size 104.27	Poles	Pages	MIXO Modular Inserts	Pages
CNE	16 A	24 + ⊕ B.41	CSS	16 A	24 + ⊕ B.121	MIXO modules	C.12-93
CCE	16 A	24 + ⊕ B.47	CMCE / CMSH	16 A	10 + 2 (aux.) + ⊕ B.146,151	CX 06 T (6-slot sized MIXO frames)	C.95
CSH / JSH S	16 A	24 + ⊕ B.55,61	CX	100 A/16 A	8/0 and 6/6 + ⊕ B.156-157		
CSHT	16 A	24 + ⊕ B.68	CX / CXC	80 A/16 A	4/8 + ⊕ B.161-162		
CQE / CQEY	16 A	46 + ⊕ B.75,85					
CQEE	16 A	64 + ⊕ B.79					
CD	10 A	64 + ⊕ B.91					
CDD	10 A	108 + ⊕ B.97					
CDSH	10 A	42 + ⊕ B.105					

Accessories:

CR YLK24
Locking device
Page G.44

CR YLK24 SL
Locking device
Page G.44

Panel cut-out drawings

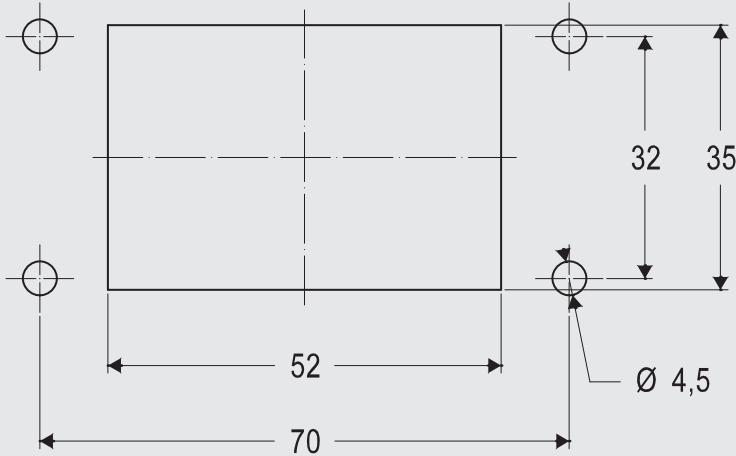
For Central lever series bulkhead mounting housings

To guarantee the declared IP degree of protection of the housings reported in this catalogue, according to EN IEC 60529 or to the relevant Type rating per ANSI/UL 50 and 50E (for those products bearing approval to those ratings), the surface of the mounting panel must meet the following requirements (definitions are provided in ISO 4287 standard):

Waviness $Wt \leq 0,2$ mm over a distance of 200 mm (measured on the panel without load)
Roughness $Ra \leq 16$ μ m

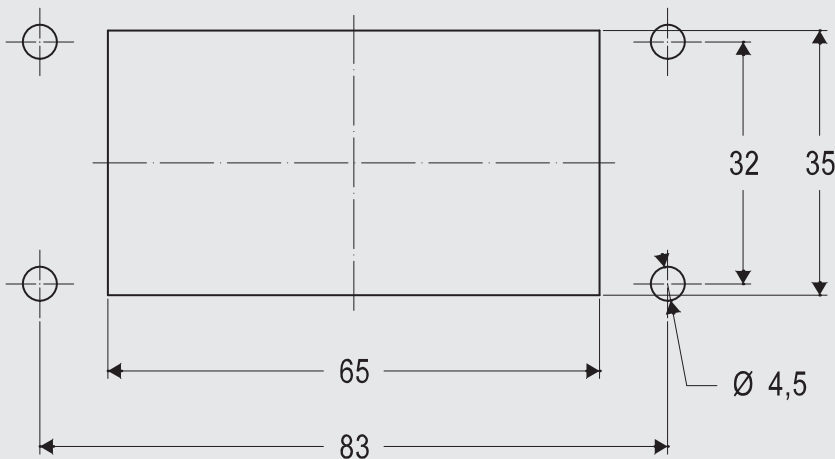
Scale 1:1

Size 44.27



Required screws: 4
Screws size: M4
Recommended torque:
 0,8 – 1,2 Nm / 7.1 – 10.6 lb.in

Size 57.27



Required screws: 4
Screws size: M4
Recommended torque:
 0,8 – 1,2 Nm / 7.1 – 10.6 lb.in

Notes: The values of tightening torque indicated above are just recommended values, that must be related – by the designer of the final application – to the resistance class of the screws (not included), with the assumption that the mounting panel is sufficiently rigid (stiff). If the deflection of the panel, under the effect of tightening the screws, is greater than 0,7 mm over a distance of 100 mm, it is

necessary to use the counter-flanges mentioned in our catalogue or the special flange gaskets available upon request (please contact our Sales Department).

Panel cut-out drawings

For Central lever series bulkhead mounting housings

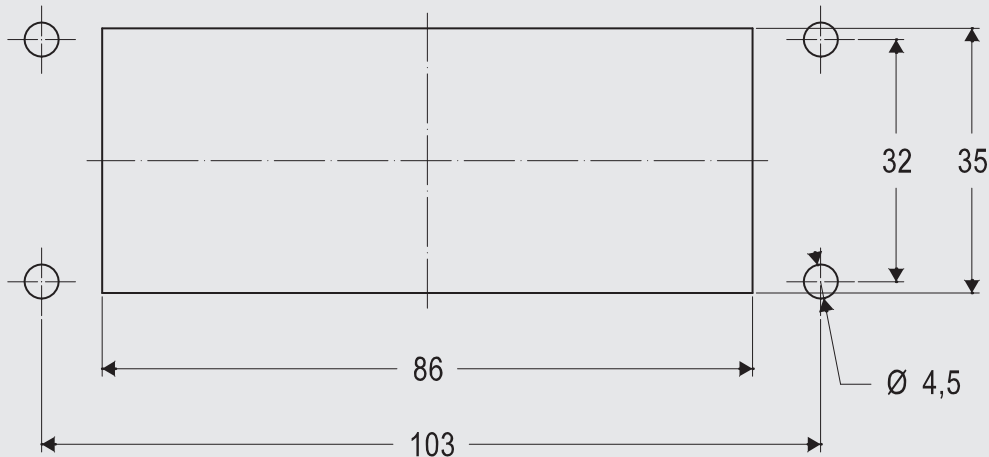
To guarantee the declared IP degree of protection of the housings reported in this catalogue, according to EN IEC 60529 or to the relevant Type rating per ANSI/UL 50 and 50E (for those products bearing approval to those ratings), the surface of the mounting panel must meet the following requirements (definitions are provided in ISO 4287 standard):

Waviness $Wt \leq 0,2$ mm over a distance of 200 mm
(measured on the panel without load)

Roughness $Ra \leq 16$ μm

Scale 1:1

Size 77.27



Required screws: 4
Screws size: M4
Recommended torque:
0,8 – 1,2 Nm / 7.1 – 10.6 lb.in

Size 104.27



Required screws: 4
Screws size: M4
Recommended torque:
0,8 – 1,2 Nm / 7.1 – 10.6 lb.in

Notes: The values of tightening torque indicated above are just recommended values, that must be related – by the designer of the final application – to the resistance class of the screws (not included), with the assumption that the mounting panel is sufficiently rigid (stiff). If the deflection of the panel, under the effect of tightening the screws, is greater than 0,7 mm over a distance of 100 mm, it is

necessary to use the counter-flanges mentioned in our catalogue or the special flange gaskets available upon request (please contact our Sales Department).



BIG series

The space you have always needed



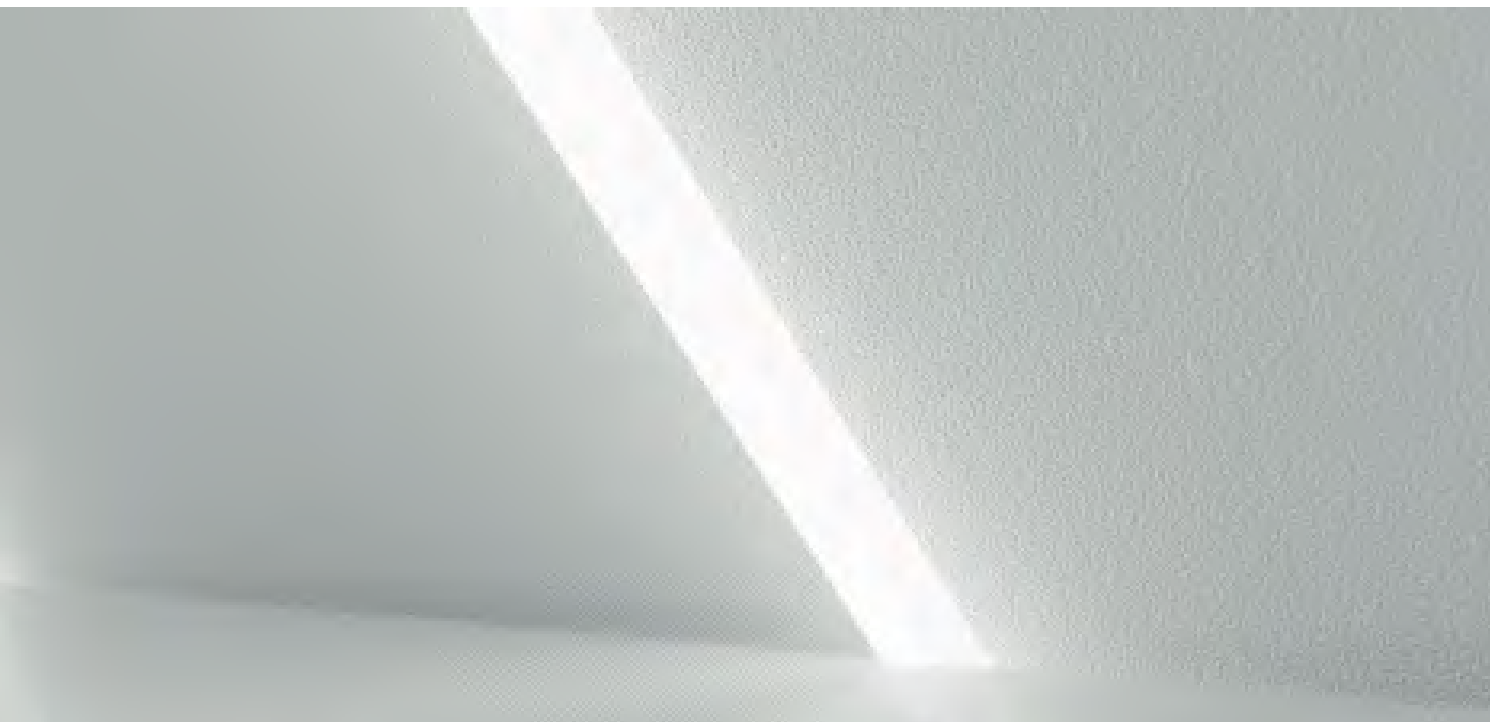
BIG series

BIG series introduces a significant change in the hood design and has been specifically developed to meet the wiring market's requirements in terms of conductor dimension and installation space.

The enclosures integrate the existing inserts range and are ideal for structured and complex wiring installations (e.g., power contacts with large wire cross-sections, pneumatic contacts and large wire bundles).



Watch our clip



SUM-UP

- > The BIG enclosures are made in die-cast aluminum alloy and are fitted with cast pegs with a reinforced design, painted with epoxy-polyester powder paint.
- > The sealing gasket in anti-aging NBR elastomer, resistant to oils and fuels, is positioned internally to guarantee a greater protection from light and atmospheric agents.
- > BIG enclosures guarantee an IP67 protection rating (EN 60529) after the connector has been coupled with V-TYPE series - IP67 version housings, and completed with appropriate cable glands; they are manufactured in compliance with standard IEC/EN 61984.
- > Ambient temperature range -40 °C / +125 °C.
- > Versions for aggressive environments (W-TYPE series) are also available upon request.

❖ Markings and Approvals

- CE and UK markings, EAC not applicable
- UL certified for USA and Canada for Type 12, 4 and 4X degrees of protection (enclosure type ratings, equivalent to NEMA rating)
- IP65 / IP66 / IP69 degree of protection
- IP65 / IP66 / IP67 / IP69 degree of protection when coupled with V-TYPE series - IP67 version housings
- RoHS: compliant

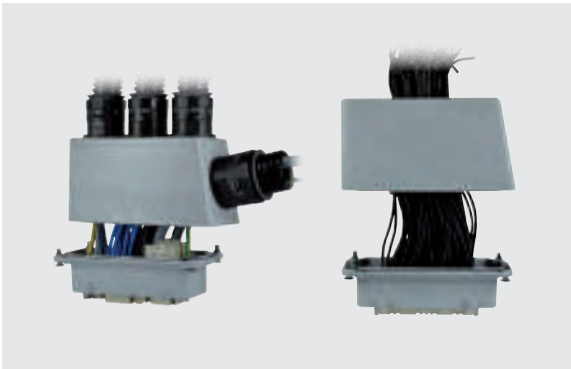


BIG series

The space you have always needed

The large dimensions of these innovative enclosures have been chosen to offer customers an adequate space to store conductors. **The width of the enclosures is greater than that of previous versions:** 66 mm compared to the 43 mm for standard enclosures.

The height of BIG enclosures has also been increased to 100 mm for sizes 44.27 and 57.27 (standard versions for high models: 70 and 72 mm), and to 110 mm for sizes 77.27 and 104.27 (standard versions for high models: 76 mm).



Ease of use

The cable compartment is fully accessible during assembly, offering three times the space compared to standard enclosures. The two separate halves of the hood simplify the installation of the insert.

Simplified installation

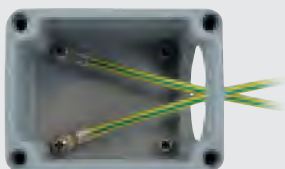
Installation operations for the hoods are simple and fast. No special accessories, tools or expensive additional operations are required. The lower half of the enclosure must be fixed to the upper half using the four screws supplied. It is possible to prevent the fixing screws from coming loose by fitting on each screw the O-ring seal provided with the enclosures.

Options for the connection of control and signalling devices

The thickness of each hood is enough to host multiple threaded cable entries. BIG enclosures enable the connection of push buttons, selectors, switches, and signalling lamps after the necessary holes have been prepared.

Compartment for electronic boards

It is possible to install electronic boards in the upper section of enclosures with side entry. In this case, it is, however, necessary to order CR MBS screws separately to fix the board in place.



Greater protection

It is also possible to fix one earthing terminal in the upper half of the enclosure to protect indirect contacts. In this case, it is however necessary to order separate earthing terminal CR MBT, consisting of fixing screws and a wire terminal for 6 mm² conductors.

WARNING

Due to the **considerable weight** of BIG hoods, when fitted with inserts, conductors and cable glands, we recommend to use them in combination with housings fitted with V-TYPE closing levers (C7/M7/CV/MV).

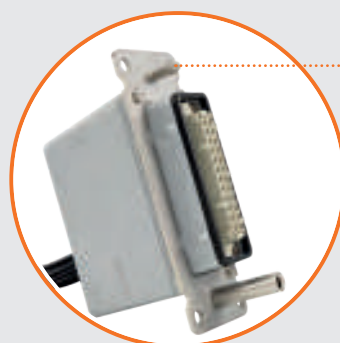
If used in combination with enclosures series CLASS, it is advisable to appropriately anchor the cables in order to prevent their weight from being applied to the closing levers.

FOCUS

BIG Hoods with integrated self-centring floating frame

These special variants of the series BIG connector enclosures (a series which is proprietary ILME design) consist of two hoods, one with edge gasket, the other without, both equipped with dedicated variant of robust stainless steel special self-centring floating frame.

They are designed to allow electrical (power and signal) connection between two pieces of equipment (both fixed, one foreseen for frequent swap), guided by a dedicated special self-centring floating frame.



▶ BIG special hoods with integrated special self-centring floating frame allow guided, frequent swaps avoiding damages and ingress of contaminants

BIG series – Multiple cable entries

size **44.27**

Hoods with 2 pegs

Heavy-Duty Applications



EN 60529	IP65 / IP66 / IP69
When coupled with V-TYPE series - IP67 version	IP65 / IP66 / IP67 / IP69
UL 50 / UL 50E	Type 12 / 4 / 4X
Ambient temperature limits	-40 °C ... +125 °C
Mechanical life (cycles)	≥ 500

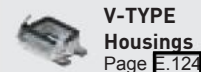


ALUS ECBT2.E115072 | ECBT8.E115072

Item	Description	Part No.	Entry	Dimension	
	Hoods with 2 pegs, side and/or top entry, without gasket To be used only with a complete cable gland	Side entry MBO 06 L40 MBO 06 L50	Top entry MBV 06 L40 MBV 06 L50		
		Side and Top entries MBVO 06 L240			M40 M50 M40 × 2
		Without entry CBC 06 L			M40 × 2
	Hoods with 2 pegs, designed to be drilled, without gasket	CBC 06 L			
	Hoods with 2 pegs, 2 x top entries, without gasket To be used only with a complete cable gland	MBV 06 L225	M25 × 2	<p>MBV 06 L225</p>	
	Hoods with 2 pegs, 3 x top entries, without gasket To be used only with a complete cable gland	MBV 06 L320	M20 × 3	<p>MBV 06 L320</p>	

Inserts size 44.27	Poles	Pages	MIXO Modular Inserts	Pages
CNE	16 A	6 + ⊕	MIXO modules	C.12-93
CCE	16 A	6 + ⊕	CX 02 T (2-slot sized MIXO frames)	C.95
CSH / JSH S	16 A	6 + ⊕		
CQE / CQEY	16 A	10 + ⊕		
CDD	10 A	24 + ⊕		
CDSH / CDSH NC	10 A	9 and 6 + ⊕		
CSS	16 A	6 + ⊕		

Complete with:



BIG
E

BIG series – Multiple cable entries

size **57.27**


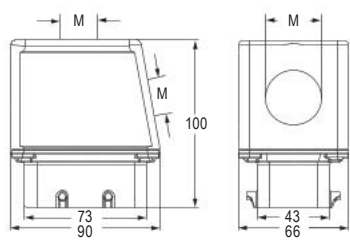

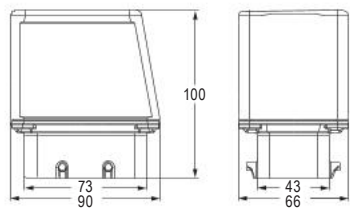



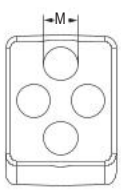
Hoods with 4 pegs

Heavy-Duty Applications


EN 60529	IP65 / IP66 / IP69
When coupled with V-TYPE series - IP67 version	IP65 / IP66 / IP67 / IP69
UL 50 / UL 50E	Type 12 / 4 / 4X
Ambient temperature limits	-40 °C ... +125 °C
Mechanical life (cycles)	≥ 500

CE UK


 ECBT2.E115072 | ECBT8.E115072

Item	Description	Part No.	Entry	Dimension	
	Hoods with 4 pegs, side and/or top entry, without gasket To be used only with a complete cable gland	Side entry	Top entry		
		MBO 10.40 MBO 10.50	MBV 10.40 MBV 10.50		M40 M50
		Side and Top entries			M40 × 2
		MBVO 10.240			
	Hoods with 4 pegs, designed to be drilled, without gasket	Without entry			
		CBC 10			
	Hoods with 4 pegs, 2 x top entries, without gasket To be used only with a complete cable gland		MBV 10.225	M25 × 2	
					
				MBV 10.225	
	Hoods with 4 pegs, 4 x top entries, without gasket To be used only with a complete cable gland		MBV 10.420	M20 × 4	
					
				MBV 10.420	

Inserts size 57.27	Poles	Pages	Inserts size 57.27	Poles	Pages		
CNE	16 A	10 + ☉	B.39	CMCE / CMSH	16 A	3 + 2 (aux.) + ☉	B.144-149
CCE	16 A	10 + ☉	B.45	CX	40 A/10 A	8/24 + ☉	B.170-171
CSH / JSH S	16 A	10 + ☉	B.53-59				
CSHT	16 A	10 + ☉	B.66				
CQE / CQEY	16 A	18 + ☉	B.73-83				
CDD	10 A	42 + ☉	B.98	MIXO Modular Inserts		Pages	
CDSH	10 A	18 + ☉	B.103	MIXO modules		C.12-93	
CSS	16 A	10 + ☉	B.119	CX 03 T (3-slot sized MIXO frames)		C.98	


Complete with:


V-TYPE Housings
 Page [E.125](#)

BIG series – Multiple cable entries

size **77.27**

Hoods with 4 pegs


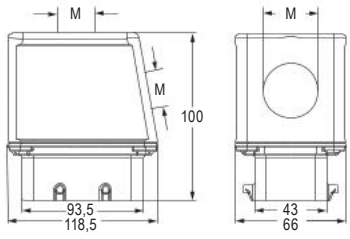

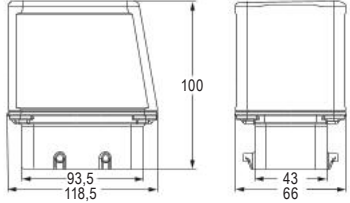

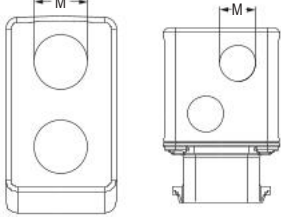

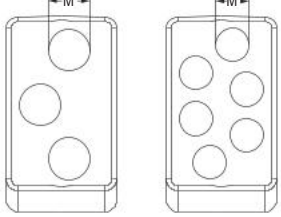
Heavy-Duty Applications 

EN 60529	IP65 / IP66 / IP69
When coupled with V-TYPE series - IP67 version	IP65 / IP66 / IP67 / IP69
UL 50 / UL 50E	Type 12 / 4 / 4X
Ambient temperature limits	-40 °C ... +125 °C
Mechanical life (cycles)	≥ 500

CE UK CA




ALUS ECBT2.E115072 | ECBT8.E115072

Item	Description	Part No.	Entry	Dimension	
	Hoods with 4 pegs, side and/or top entry, without gasket To be used only with a complete cable gland	Side entry MBO 16.40 MBO 16.50	Top entry MBV 16.40 MBV 16.50		
		Side and Top entries MBVO 16.240			M40 M50 M40 × 2
		Without entry CBC 16			
	Hoods with 4 pegs, designed to be drilled, without gasket	Without entry CBC 16			
	Hoods with 4 pegs, 2 x top or side entries, without gasket To be used only with a complete cable gland	Side entry MBO 16.225	Top entry MBV 16.232		
					M25 × 2 M32 × 2
	Hoods with 4 pegs, multiple top entries, without gasket To be used only with a complete cable gland		MBV 16.325 MBV 16.620		
			M25 × 3 M20 × 6		MBV 16.325 MBV 16.620

BIG
E

Inserts size 77.27	Poles	Pages	Inserts size 77.27	Poles	Pages	MIXO Modular Inserts	Pages
CNE	16 A	16 + ⊕	CP / CPY	35 A	6 + ⊕	MIXO modules	3.112-114
CCE	16 A	16 + ⊕	CSS	16 A	16 + ⊕	CX 04 T (4-slot sized MIXO frames)	3.120
CSH / JSH S	16 A	16 + ⊕	CMCE / CMSH	16 A	6 + 2 (aux.) + ⊕		3.145-150
CSHT	16 A	16 + ⊕	CX / CXC	80 A/16 A	4/0, 4/2 + ⊕		3.158-160
CQE / CQEY	16 A	32 + ⊕	CX	40 A/10 A	6/12, 6/36, 9/42 and 12/2 + ⊕		3.163-164, 168-169
CQEE	16 A	40 + ⊕					
CD	10 A	40 + ⊕					
CDD	10 A	72 + ⊕					
CDSH	10 A	27 + ⊕					

Complete with:



V-TYPE Housings
Page [E.126](#)

BIG series – Multiple cable entries

size **104.27**

Hoods with 4 pegs

**Heavy-Duty
Applications**


EN 60529	IP65 / IP66 / IP69
When coupled with V-TYPE series - IP67 version	IP65 / IP66 / IP67 / IP69
UL 50 / UL 50E	Type 12 / 4 / 4X
Ambient temperature limits	-40 °C ... +125 °C
Mechanical life (cycles)	≥ 500



ECBT2.E115072 | ECBT8.E115072

Item	Description	Part No.	Entry	Dimension	
	Hoods with 4 pegs, side and/or top entry, without gasket To be used only with a complete cable gland	Side entry	Top entry		
		MBO 24.40 MBO 24.50	MBV 24.40 MBV 24.50		M40 M50
		Side and Top entries	MBVO 24.250		M50 × 2
	Hoods with 4 pegs, designed to be drilled, without gasket	Without entry			
	Hoods with 4 pegs, 2 x top or side entries, without gasket To be used only with a complete cable gland	Side entry	Top entry		
		MBO 24.225	MBV 24.240		M25 × 2 M40 × 2
	Hoods with 4 pegs, multiple top entries, without gasket To be used only with a complete cable gland				
		MBV 24.332 MBV 24.425 MBV 24.720		M32 × 3 M25 × 4 M20 × 7	

Inserts size 104.27	Poles	Pages	Inserts size 104.27	Poles	Pages	MIXO Modular Inserts	Pages
CNE	16 A	24 + ⊕	CSS	16 A	24 + ⊕	MIXO modules	3.12-93
CCE	16 A	24 + ⊕	CMCE / CMSH	16 A	10 + 2 (aux.) + ⊕	CX 06 T (6-slot sized MIXO frames)	3.93
CSH / JSH S	16 A	24 + ⊕	CX	100 A/16 A	8/0 and 6/6 + ⊕		3.156-157
CSHT	16 A	24 + ⊕	CX / CXC	80 A/16 A	4/8 + ⊕		3.161-162
CQE / CQEY	16 A	46 + ⊕					
CQEE	16 A	64 + ⊕					
CD	10 A	64 + ⊕					
CDD	10 A	108 + ⊕					
CDSH	10 A	42 + ⊕					

Complete with:

**V-TYPE
Housings**
Page [E.127](#)

BIG series – Multiple cable entries

Hoods with integrated special self-centring floating frame

size **44.27**

Heavy-Duty Applications

EN 60529	IP66 / IP67 / IP69
UL 50 / UL 50E	Type 12 / 4 / 4X
Ambient temperature limits	-40 °C ... +125 °C
Mechanical life (cycles)	
- with standard inserts	≥ 500
- with HNM inserts	≥ 10 000

CE UK

(pending: CQC, DNV and BV)

(pending: cURus)

Item	Description	Part No.	Entry	Dimension
------	-------------	----------	-------	-----------

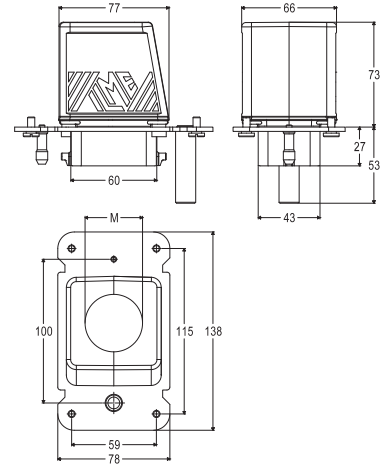


Hoods with 2 pegs, top entry, without gasket, with integrated special self-centring floating frame

[MBV 06.40D](#)

M40

To be used only with a complete cable gland



! CAUTION:

Due to the absence of locking means, the IP66 / IP67 / IP69 achievable degree of protection is demanded to the end-use application:

- 1) Suitable pressure, in order to uniformly compress the sealing gasket and keep the connector coupling tight is required: this condition is satisfied when the self-centring guide pins and contact tubes reach their end-of-run and are kept constantly in this position;
- 2) Suitably rated cable entry devices (e.g. cable glands) are required to maintain the desired IP degree of protection.

Protection against undue opening under load (connectors without breaking capacity) and closing under voltage is demanded to the end-use application, e.g. by suitable detection of such conditions.

Inserts size 44.27	Poles	Pages	MIXO Modular Inserts	Pages	
CNE	16 A	6 + ⊕	B.38	MIXO modules	C.12-93
CCE	16 A	6 + ⊕	B.44	CX 02 T (2-slot sized MIXO frames)	C.95
CSH / JSH S	16 A	6 + ⊕	B.52,58		
CQE / CQEY	16 A	10 + ⊕	B.72,82		
CDD	10 A	24 + ⊕	B.94		
CDSH / CDSH NC	10 A	9 and 6 + ⊕	B.102,108		
CSS	16 A	6 + ⊕	B.118		

BIG series – Multiple cable entries


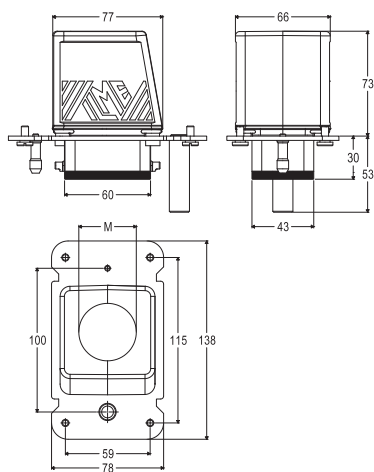
Hoods with integrated special self-centring floating frame

size **44.27**
Heavy-Duty Applications

EN 60529	IP66 / IP67 / IP69
UL 50 / UL 50E	Type 12 / 4 / 4X
Ambient temperature limits	-40 °C ... +125 °C
Mechanical life (cycles)	
- with standard inserts	≥ 500
- with HNM inserts	≥ 10 000

(pending: CQC, DNV and BV)

(pending: cURus)


Item	Description	Part No.	Entry	Dimension
	<p>Hoods with 2 pegs, top entry, with gasket, with integrated special self-centring floating frame</p> <p>To be used only with a complete cable gland</p> <p>! CAUTION: Due to the absence of locking means, the IP66 / IP67 / IP69 achievable degree of protection is demanded to the end-use application:</p> <p>1) Suitable pressure, in order to uniformly compress the sealing gasket and keep the connector coupling tight is required: this condition is satisfied when the self-centring guide pins and contact tubes reach their end-of-run and are kept constantly in this position;</p> <p>2) Suitably rated cable entry devices (e.g. cable glands) are required to maintain the desired IP degree of protection.</p> <p>Protection against undue opening under load (connectors without breaking capacity) and closing under voltage is demanded to the end-use application, e.g. by suitable detection of such conditions.</p>	MBV 06.40DG	M40	

Inserts size 44.27	Poles	Pages	MIXO Modular Inserts	Pages
CNE	16 A	6 + ⊕	B.38	
CCE	16 A	6 + ⊕	B.44	C.12-93
CSH / JSH S	16 A	6 + ⊕	B.52,58	
CQE / CQEY	16 A	10 + ⊕	B.72,82	
CDD	10 A	24 + ⊕	B.94	
CDSH / CDSH NC	10 A	9 and 6 + ⊕	B.102,108	
CSS	16 A	6 + ⊕	B.118	
			CX 02 T (2-slot sized MIXO frames)	C.95

BIG series – Multiple cable entries

Hoods with integrated special self-centring floating frame

size **57.27**


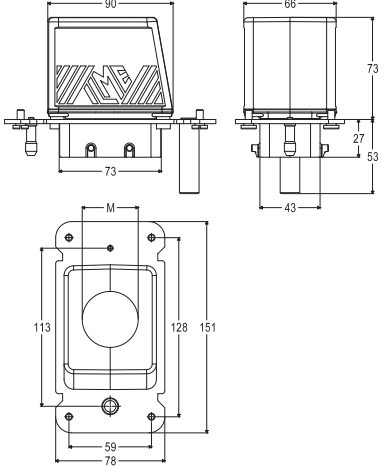
Heavy-Duty Applications 

EN 60529	IP66 / IP67 / IP69
UL 50 / UL 50E	Type 12 / 4 / 4X
Ambient temperature limits	-40 °C ... +125 °C
Mechanical life (cycles)	
- with standard inserts	≥ 500
- with HNM inserts	≥ 10 000

CE UK CA

(pending: CQC, DNV and BV)

(pending: cURus)

Item	Description	Part No.	Entry	Dimension
	<p>Hoods with 4 pegs, top entry, without gasket, with integrated special self-centring floating frame</p> <p>To be used only with a complete cable gland</p> <p>! CAUTION: Due to the absence of locking means, the IP66 / IP67 / IP69 achievable degree of protection is demanded to the end-use application:</p> <p>1) Suitable pressure, in order to uniformly compress the sealing gasket and keep the connector coupling tight is required: this condition is satisfied when the self-centring guide pins and contact tubes reach their end-of-run and are kept constantly in this position;</p> <p>2) Suitably rated cable entry devices (e.g. cable glands) are required to maintain the desired IP degree of protection.</p> <p>Protection against undue opening under load (connectors without breaking capacity) and closing under voltage is demanded to the end-use application, e.g. by suitable detection of such conditions.</p>	MBV 10.40D	M40	

BIG
E

Inserts size 57.27	Poles	Pages	Inserts size 57.27	Poles	Pages		
CNE	16 A	10 + ⊕	B.39	CMCE / CMSH	16 A	3 + 2 (aux.) + ⊕	B.144,149
CCE	16 A	10 + ⊕	B.45	CX	40 A/10 A	8/24 + ⊕	B.170-171
CSH / JSH S	16 A	10 + ⊕	B.53,59				
CSHT	16 A	10 + ⊕	B.66				
CQE / CQEY	16 A	18 + ⊕	B.73,83				
CDD	10 A	42 + ⊕	B.95	MIXO Modular Inserts		Pages	
CDSH	10 A	18 + ⊕	B.103	MIXO modules		C.12-93	
CSS	16 A	10 + ⊕	B.119	CX 03 T (3-slot sized MIXO frames)		C.95	

BIG series – Multiple cable entries

Hoods with integrated special self-centring floating frame


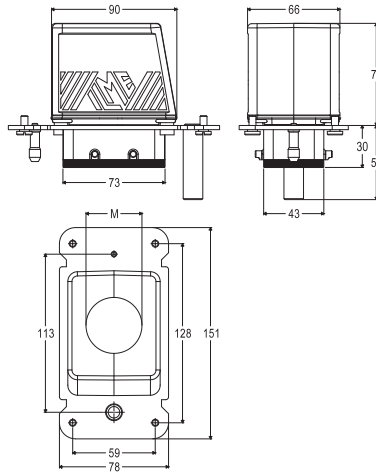
size **57.27**
**Heavy-Duty
Applications**


EN 60529	IP66 / IP67 / IP69
UL 50 / UL 50E	Type 12 / 4 / 4X
Ambient temperature limits	-40 °C ... +125 °C
Mechanical life (cycles)	
- with standard inserts	≥ 500
- with HNM inserts	≥ 10 000

CE UK

(pending: CQC, DNV and BV)

(pending: cURus)


Item	Description	Part No.	Entry	Dimension
	<p>Hoods with 4 pegs, top entry, with gasket, with integrated special self-centring floating frame</p> <p>To be used only with a complete cable gland</p> <p>! CAUTION: Due to the absence of locking means, the IP66 / IP67 / IP69 achievable degree of protection is demanded to the end-use application:</p> <p>1) Suitable pressure, in order to uniformly compress the sealing gasket and keep the connector coupling tight is required: this condition is satisfied when the self-centring guide pins and contact tubes reach their end-of-run and are kept constantly in this position;</p> <p>2) Suitably rated cable entry devices (e.g. cable glands) are required to maintain the desired IP degree of protection.</p> <p>Protection against undue opening under load (connectors without breaking capacity) and closing under voltage is demanded to the end-use application, e.g. by suitable detection of such conditions.</p>	MBV 10.40DG	M40	

Inserts size 57.27	Poles	Pages	Inserts size 57.27	Poles	Pages		
CNE	16 A	10 + ⊕	B.39	CMCE / CMSH	16 A	3 + 2 (aux.) + ⊕	B.144,149
CCE	16 A	10 + ⊕	B.45	CX	40 A/10 A	8/24 + ⊕	B.170-171
CSH / JSH S	16 A	10 + ⊕	B.53,59				
CSHT	16 A	10 + ⊕	B.66				
CQE / CQEY	16 A	18 + ⊕	B.73,83				
CDD	10 A	42 + ⊕	B.95				
CDSH	10 A	18 + ⊕	B.103				
CSS	16 A	10 + ⊕	B.119				
				MIXO Modular Inserts		Pages	
				MIXO modules		C.12-93	
				CX 03 T (3-slot sized MIXO frames)		C.95	

BIG series – Multiple cable entries

Hoods with integrated special self-centring floating frame

size **77.27**


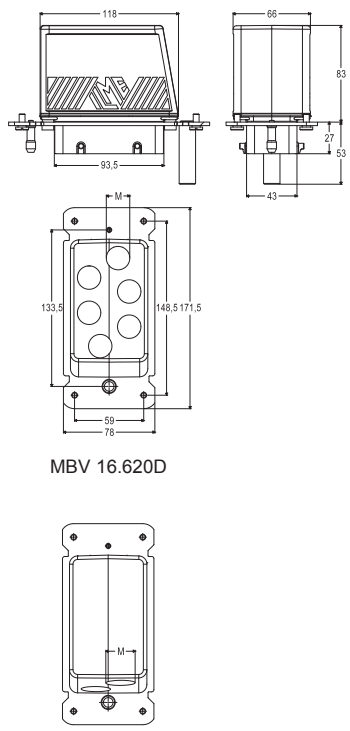
Heavy-Duty Applications 

EN 60529	IP66 / IP67 / IP69
UL 50 / UL 50E	Type 12 / 4 / 4X
Ambient temperature limits	-40 °C ... +125 °C
Mechanical life (cycles)	
- with standard inserts	≥ 500
- with HNM inserts	≥ 10 000

CE UK CA

(pending: CQC, DNV and BV)

(pending: cURus)

Item	Description	Side entry	Top entry	Entry	Dimension
	<p>Hoods with 4 pegs, multiple side or top entries, without gasket, with integrated special self-centring floating frame</p> <p>To be used only with a complete cable gland</p> <p>! CAUTION: Due to the absence of locking means, the IP66 / IP67 / IP69 achievable degree of protection is demanded to the end-use application:</p> <p>1) Suitable pressure, in order to uniformly compress the sealing gasket and keep the connector coupling tight is required: this condition is satisfied when the self-centring guide pins and contact tubes reach their end-of-run and are kept constantly in this position;</p> <p>2) Suitably rated cable entry devices (e.g. cable glands) are required to maintain the desired IP degree of protection.</p> <p>Protection against undue opening under load (connectors without breaking capacity) and closing under voltage is demanded to the end-use application, e.g. by suitable detection of such conditions.</p>	MBO 16.225D	MBV 16.620D	M20 × 6 M25 × 2	 <p>MBV 16.620D</p> <p>MBO 16.225D</p>

BIG
E

Inserts size 77.27	Poles	Pages	Inserts size 77.27	Poles	Pages	MIXO Modular Inserts	Pages
CNE	16 A	16 + ☉ B.40	CP / CPY	35 A	6 + ☉ B.112,114	MIXO modules	C.12-93
CCE	16 A	16 + ☉ B.46	CSS	16 A	16 + ☉ B.120	CX 04 T (4-slot sized MIXO frames)	C.95
CSH / JSH S	16 A	16 + ☉ B.54,60	CMCE / CMSH	16 A	6 + 2 (aux.) + ☉ B.145,150		
CSHT	16 A	16 + ☉ B.67	CX / CXC	80 A/16 A	4/0, 4/2 + ☉ B.158-160		
CQE / CQEY	16 A	32 + ☉ B.74,84	CX	40 A/10 A	6/12, 6/36, 9/42 and 12/2 + ☉ B.163-164, 168-169		
CQEE	16 A	40 + ☉ B.78					
CD	10 A	40 + ☉ B.90					
CDD	10 A	72 + ☉ B.94					
CDSH	10 A	27 + ☉ B.104					

BIG series – Multiple cable entries


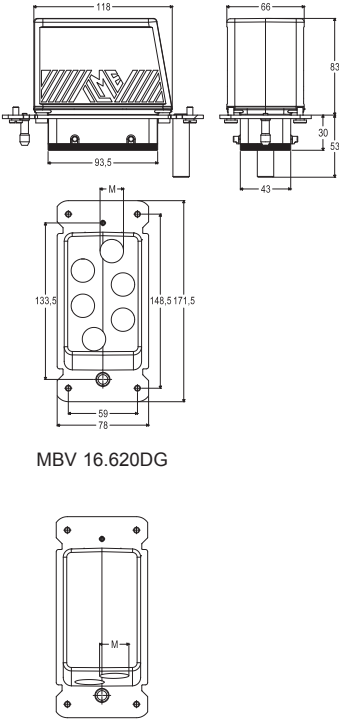
Hoods with integrated special self-centring floating frame

size **77.27**
Heavy-Duty Applications

EN 60529	IP66 / IP67 / IP69
UL 50 / UL 50E	Type 12 / 4 / 4X
Ambient temperature limits	-40 °C ... +125 °C
Mechanical life (cycles)	
- with standard inserts	≥ 500
- with HNM inserts	≥ 10 000

(pending: CQC, DNV and BV)

(pending: cURus)


Item	Description	Side entry	Top entry	Entry	Dimension
	<p>Hoods with 4 pegs, multiple side or top entries, with gasket, with integrated special self-centring floating frame</p> <p>To be used only with a complete cable gland</p> <p>! CAUTION: Due to the absence of locking means, the IP66 / IP67 / IP69 achievable degree of protection is demanded to the end-use application:</p> <p>1) Suitable pressure, in order to uniformly compress the sealing gasket and keep the connector coupling tight is required: this condition is satisfied when the self-centring guide pins and contact tubes reach their end-of-run and are kept constantly in this position;</p> <p>2) Suitably rated cable entry devices (e.g. cable glands) are required to maintain the desired IP degree of protection.</p> <p>Protection against undue opening under load (connectors without breaking capacity) and closing under voltage is demanded to the end-use application, e.g. by suitable detection of such conditions.</p>	MBO 16.225DG	MBV 16.620DG	M20 × 6 M25 × 2	 <p>MBV 16.620DG</p> <p>MBO 16.225DG</p>

Inserts size 77.27	Poles	Pages	Inserts size 77.27	Poles	Pages	MIXO Modular Inserts	Pages		
CNE	16 A	16 + ⊕	B.40	CP / CPY	35 A	6 + ⊕	B.112,114	MIXO modules	C.12-93
CCE	16 A	16 + ⊕	B.46	CSS	16 A	16 + ⊕	B.120	CX 04 T (4-slot sized MIXO frames)	C.95
CSH / JSH S	16 A	16 + ⊕	B.54,60	CMCE / CMSH	16 A	6 + 2 (aux.) + ⊕	B.145,150		
CSHT	16 A	16 + ⊕	B.67	CX / CXC	80 A/16 A	4/0, 4/2 + ⊕	B.158-160		
CQE / CQEY	16 A	32 + ⊕	B.74,84	CX	40 A/10 A	6/12, 6/36, 9/42 and 12/2 + ⊕	B.163-164, 168-169		
CQEE	16 A	40 + ⊕	B.78						
CD	10 A	40 + ⊕	B.90						
CDD	10 A	72 + ⊕	B.94						
CDSH	10 A	27 + ⊕	B.104						

BIG series – Multiple cable entries

Hoods with integrated special self-centring floating frame

size **104.27**


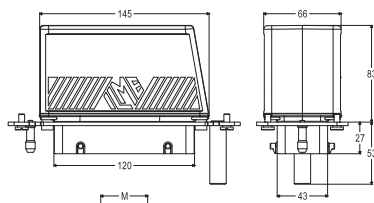
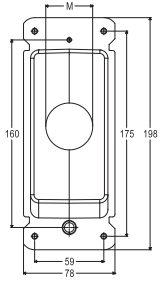
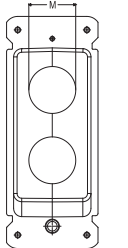
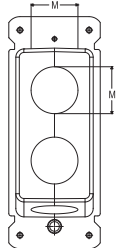
Heavy-Duty Applications 

EN 60529	IP66 / IP67 / IP69
UL 50 / UL 50E	Type 12 / 4 / 4X
Ambient temperature limits	-40 °C ... +125 °C
Mechanical life (cycles)	
- with standard inserts	≥ 500
- with HNM inserts	≥ 10 000

CE UK

 (pending: CQC)

 ECBT2.E115072 | ECBT8.E115072

Item	Description	Side entry	Top entry	Entry	Dimension
	Hoods with 4 pegs, multiple side or top entries, without gasket, with integrated special self-centring floating frame		MBV 24.40D MBV 24.240D	M40 M40 × 2	
	CQC, DNV, BV and cURus pending only for MBVO 24.440D	Side and Top entries	MBVO 24.440D	M40 × 4	
	To be used only with a complete cable gland				
	! CAUTION: Due to the absence of locking means, the IP66 / IP67 / IP69 achievable degree of protection is demanded to the end-use application:				
	1) Suitable pressure, in order to uniformly compress the sealing gasket and keep the connector coupling tight is required: this condition is satisfied when the self-centring guide pins and contact tubes reach their end-of-run and are kept constantly in this position;				
	2) Suitably rated cable entry devices (e.g. cable glands) are required to maintain the desired IP degree of protection.				
	Protection against undue opening under load (connectors without breaking capacity) and closing under voltage is demanded to the end-use application, e.g. by suitable detection of such conditions.				 MBV 24.240D
					 MBVO 24.440D

Inserts size 104.27	Poles	Pages	Inserts size 104.27	Poles	Pages	MIXO Modular Inserts	Pages
CNE	16 A	24 + ⊕	B.41	CSS	16 A	24 + ⊕	B.121
CCE	16 A	24 + ⊕	B.47	CMCE / CMSH	16 A	10 + 2 (aux.) + ⊕	B.146,151
CSH / JSH S	16 A	24 + ⊕	B.55,61	CX	100 A/16 A	8/0 and 6/6 + ⊕	B.156-157
CSHT	16 A	24 + ⊕	B.68	CX / CXC	80 A/16 A	4/8 + ⊕	B.161-162
CQE / CQEY	16 A	46 + ⊕	B.75,85				
CQEE	16 A	64 + ⊕	B.79				
CD	10 A	64 + ⊕	B.91				
CDD	10 A	108 + ⊕	B.97				
CDSH	10 A	42 + ⊕	B.105				

BIG series – Multiple cable entries

Hoods with integrated special self-centring floating frame

size **104.27**Heavy-Duty
Applications

EN 60529	IP66 / IP67 / IP69
UL 50 / UL 50E	Type 12 / 4 / 4X
Ambient temperature limits	-40 °C ... +125 °C
Mechanical life (cycles)	
- with standard inserts	≥ 500
- with HNM inserts	≥ 10 000

CE UK

(pending: CQC)

ECBT2.E115072 | ECBT8.E115072

Item	Description	Side entry	Top entry	Entry	Dimension
	Hoods with 4 pegs, multiple side or top entries, with gasket, with integrated special self-centring floating frame CQC, DNV, BV and cURus pending only for MBVO24.440DG To be used only with a complete cable gland ! CAUTION: Due to the absence of locking means, the IP66 / IP67 / IP69 achievable degree of protection is demanded to the end-use application: 1) Suitable pressure, in order to uniformly compress the sealing gasket and keep the connector coupling tight is required: this condition is satisfied when the self-centring guide pins and contact tubes reach their end-of-run and are kept constantly in this position; 2) Suitably rated cable entry devices (e.g. cable glands) are required to maintain the desired IP degree of protection. Protection against undue opening under load (connectors without breaking capacity) and closing under voltage is demanded to the end-use application, e.g. by suitable detection of such conditions.	Side and Top entries MBV24.440DG	MBV 24.40DG MBV 24.240DG	M40 M40 × 2	
				M40 × 4	

MBV 24.40DG

MBV 24.240DG

MBVO24.440DG

Inserts size 104.27	Poles	Pages	Inserts size 104.27	Poles	Pages	MIXO Modular Inserts	Pages
CNE	16 A	24 + ☉	B.41	CSS	16 A	24 + ☉	B.121
CCE	16 A	24 + ☉	B.47	CMCE / CMSH	16 A	10 + 2 (aux.) + ☉	B.146,151
CSH / JSH S	16 A	24 + ☉	B.55,61	CX	100 A/16 A	8/0 and 6/6 + ☉	B.156-157
CSHT	16 A	24 + ☉	B.68	CX / CXC	80 A/16 A	4/8 + ☉	B.161-162
CQE / CQEY	16 A	46 + ☉	B.75,85				
CQEE	16 A	64 + ☉	B.79				
CD	10 A	64 + ☉	B.91				
CDD	10 A	108 + ☉	B.97				
CDSH	10 A	42 + ☉	B.105				
						MIXO 06 T (6-slot sized MIXO frames)	C.95

Panel cut-out drawings

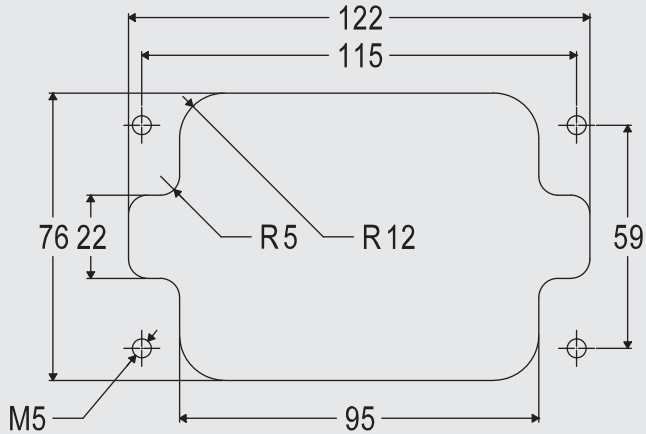
For BIG series hoods with integrated special self-centring floating frame

To guarantee the declared IP degree of protection of the housings reported in this catalogue, according to EN IEC 60529 or to the relevant Type rating per ANSI/UL 50 and 50E (for those products bearing approval to those ratings), the surface of the mounting panel must meet the following requirements (definitions are provided in ISO 4287 standard):

Waviness $Wt \leq 0,2$ mm over a distance of 200 mm (measured on the panel without load)
Roughness $Ra \leq 16$ μ m

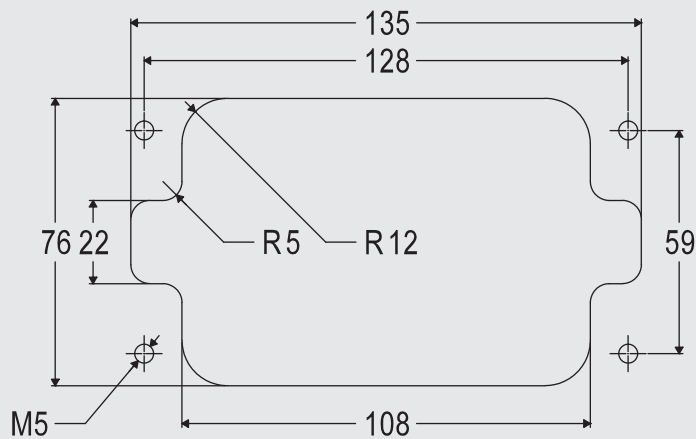
Scale 1:2

Size 44.27



Required screws: 4
Screws size: M5
Recommended torque:
 2,0 – 2,5 Nm / 17.7 – 22.1 lb.in

Size 57.27



Required screws: 4
Screws size: M5
Recommended torque:
 2,0 – 2,5 Nm / 17.7 – 22.1 lb.in

Notes: The values of tightening torque indicated above are just recommended values, that must be related – by the designer of the final application – to the resistance class of the screws (not included), with the assumption that the mounting panel is sufficiently rigid (stiff). If the deflection of the panel, under the effect of tightening the screws, is greater than 0,7 mm over a distance of 100 mm, it is

necessary to use the counter-flanges mentioned in our catalogue or the special flange gaskets available upon request (please contact our Sales Department).

Panel cut-out drawings

For BIG series hoods with integrated special self-centring floating frame

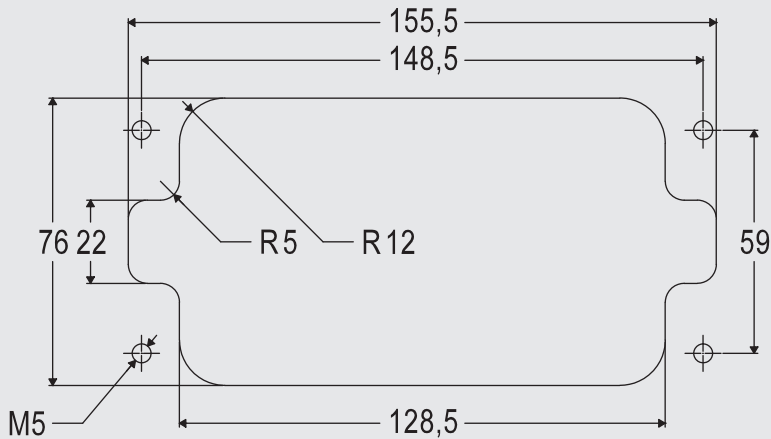
To guarantee the declared IP degree of protection of the housings reported in this catalogue, according to EN IEC 60529 or to the relevant Type rating per ANSI/UL 50 and 50E (for those products bearing approval to those ratings), the surface of the mounting panel must meet the following requirements (definitions are provided in ISO 4287 standard):

Waviness $Wt \leq 0,2$ mm over a distance of 200 mm
(measured on the panel without load)

Roughness $Ra \leq 16$ μm

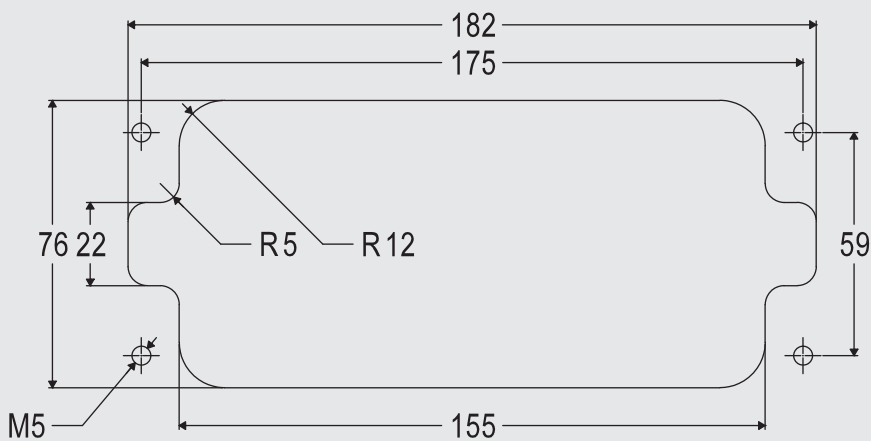
Scale 1:2

Size 77.27



Required screws: 4
Screws size: M5
Recommended torque:
 2,0 – 2,5 Nm / 17.7 – 22.1 lb.in

Size 104.27



Required screws: 4
Screws size: M5
Recommended torque:
 2,0 – 2,5 Nm / 17.7 – 22.1 lb.in

Notes: The values of tightening torque indicated above are just recommended values, that must be related – by the designer of the final application – to the resistance class of the screws (not included), with the assumption that the mounting panel is sufficiently rigid (stiff). If the deflection of the panel, under the effect of tightening the screws, is greater than 0,7 mm over a distance of 100 mm, it is

necessary to use the counter-flanges mentioned in our catalogue or the special flange gaskets available upon request (please contact our Sales Department).



COB series

Functionality counts



COB System

The COB system of panel supports makes it possible to use multipole connectors within electric panels without the traditional metallic enclosures as protection is assured by the electric panel itself or other container.

WARNING

Connectors must not be connected and disconnected under load or when live.

The COB system satisfies the most varied installation needs thanks to the interchangeability of the connector inserts. The inserts can be installed as per Table 1. at page E.285.

In addition, the **COB...BC** supports may house the ILME **CR..AD1** and **CR..AD2** series plates for the D-SUB inserts (miniature-connectors).

The COB system is approved by **UL** as support for multipole connectors (UL ECBT2 and ECBT8 file E115072), as well as by **DNV** and **Bureau Veritas** maritime applications on board ships.

SUM-UP

- > Reduction in cost and space with respect to metallic enclosures plus traditional terminal blocks enabling “modular” wiring inside panels, very handy in case of maintenance: fast replacement of devices and entire sections leading to shorter downtime.
- > Possibility of pre-wiring and testing of the connectors at bench, fastening the commissioning of the installation on site.
- > Easy wiring inspection and tests with coupled connectors, thanks to rear access to the inserts by the overturning (connector hinged and locked on the base support).
- > Fast mounting in panels thanks to the snap fastening device on the DIN EN 60715 rails.
- > Sturdy support structure, specific to the size of each insert, it does not require any preparation.
- > Broad passage for housing of conductor cables.
- > Mobile parts prearranged for the clamping of bundles of conductors of multi-core cables, to prevent contact with the connector contacts.



Watch our clip



Functional characteristics

- > The system may be assembled on panels with window snap fastening device; on DIN EN 60715 rails, both lengthways and crossways to the support; on fixed panels using screws.
- > Reduction in cost and space with respect to metallic enclosures and traditional terminal boards.
- > Possibility of rewiring at the connector bench with connected devices.
- > Easy wiring inspection and tests with coupled connectors, thanks to rear access to the inserts via the turnover device.
- > Fast mounting in panels thanks to the snap fastening device on the DIN EN 60715 rails.
- > Sturdy support structure, specific to the size of each insert and does not require any preparation.
- > Broad passage for housing of conductor cables.
- > Mobile parts prearranged for the clamping of bundles of conductors of multipolar cables to prevent contact with the connector contacts.
- > IP20 degree of protection.

Material characteristics

- > Self-extinguishing thermoplastic insulating materials, UL certified (COB supports, locking levers, hoods), compatible with the -40 °C / +125 °C operating temperature range of connector inserts.

❖ Markings and Approvals

- CE and UKA markings, EAC not applicable
- IP20
- RoHS: compliant

COB series

Functionality counts

PRODUCTS DETAILS

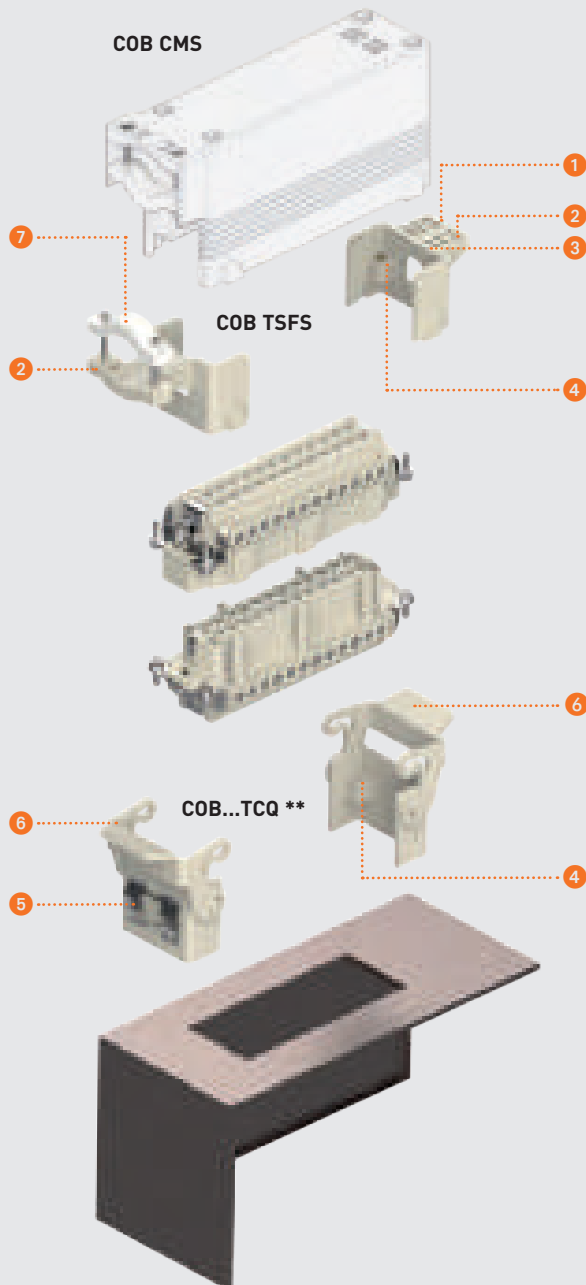


Figure 1
COB TCQ + COB TSFS
 (COB CMS, alternative)

- Snap fastening in ** window, panels or control panels.

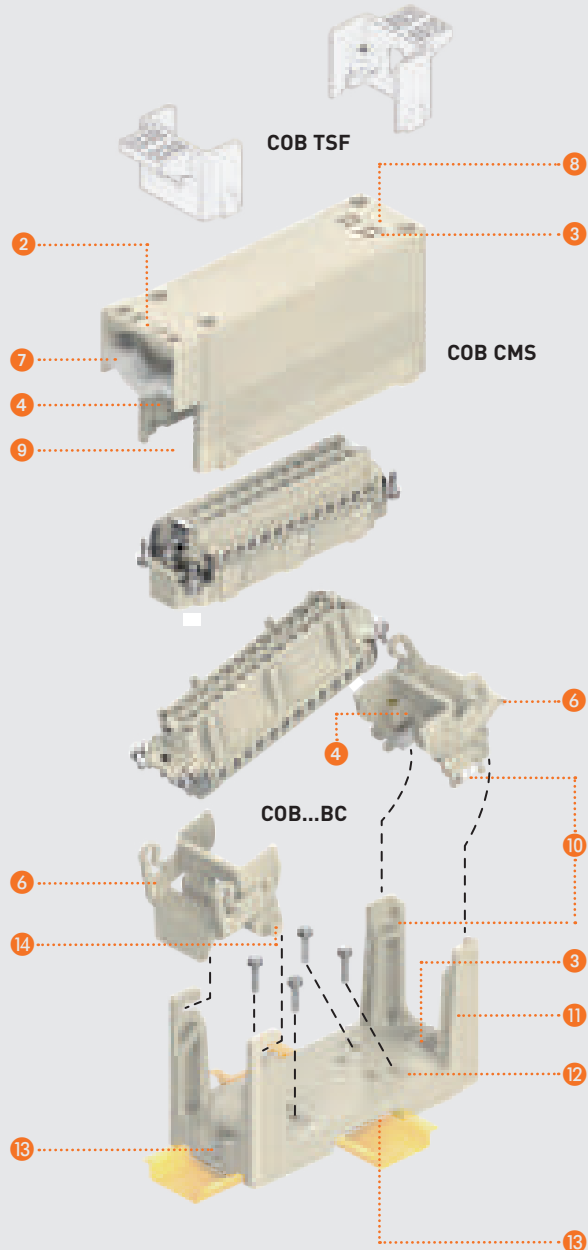


Figure 2
COB..BC + COB..CMS
 (COB TSF, alternative)

- Snap fastening on DIN EN 60715 rails both lengthways and crossways to the support
 - Installation in panels or control panels, with fixed fastening with screws.

The **COB** system may be assembled in the three following ways:

- > **On panels** with window snap fastening device (**Figure 1**).
- > **On DIN EN 60715 rails**, both lengthways and crossways to the support (**Figure 2**).
- > **On fixed panels** using screws (**Figure 2**).

- 1 **COB, TSF** or **COB TSFS** insert support blocks (with cable clamp) for mobile mounting, in self-extinguishing thermoplastic material.
- 2 Passage for cable support bands (from 2,2 to 4,8 mm).
- 3 Locations for insertion of identification tags (size 9 x 20 mm).
- 4 Threaded metallic inserts for screws to fix the connectors and possibility of coded connection with the use of specific pins (ILME part: CR 20, CRM, CRF, CR 20 CX, CRM CX and CRF CX) when identical connectors are used.
- 5 **COB TCQ** insert carrier block for window mounting in self-extinguishing thermoplastic material, with spring snap fastening.
- 6 Locking device with levers in self-extinguishing thermoplastic material for insert coupling.
- 7 Sturdy cable clamp for clamping multipolar cables with a diameter of up to 25 mm or bundles of unipolar conductors.
- 8 **COB CMS** enclosure for mobile mounting, in self-extinguishing thermoplastic material, IP20 degree of protection.
- 9 Free passage for mounting wired insert with conductor cables.
- 10 Releasable block (latch actuated by pushbutton) [in **COB..BC** kit] in self-extinguishing thermoplastic material, with quick release device for insert turnover, wiring operations, verifications and maintenance
- 11 **COB..BC** panel support for bulkhead mounting in self-extinguishing thermoplastic material, sturdy block support structure, with broad passage for housing of conductor cables.
- 12 Holes for fixed fastening with screws without DIN EN 60715 rails.
- 13 Snap fastening on DIN EN 60715 rails, both lengthways and crossways to the support.
- 14 Rollover pins that can be released and allow the use of pre-wired inserts.

Table 1

Supports for connector inserts

types	COB TCQ			
fixed	COB 06 BC	COB 10 BC	COB 16 BC	COB 24 BC
types	COB TSF and COB TSFS			
mobile	COB 06 CMS	COB 10 CMS	COB 16 CMS	COB 24 CMS

Insert size

			49.16*	
			66.16*	
	44.27	57.27	77.27	104.27

Insert series and polarity + ⊖

CX CXC		8/24	4/0, 4/2, 12/2, 9/42, 6/12, 6/36	8/0, 6/6, 4/8
CP – CPY			6	
CQE – CQEY CQEE	10	18	32	46
CNE – CCE CSH – JSH..S	6	10	16	24
CSHT		10	16	24
CDA – CDC CSAH			10*, 16*	
CMCE CMSH		3 + 2	6 + 2	10 + 2
CD – CDY	24	40	15*, 25*, 64	
CDD		42	38*, 72	108
CDSH	9	18	27	42
CDSH NC	6			
MIXO	2 slots	3 slots	4 slots	6 slots

* for mounting via adapter plates, see page E.290.

COB series – System for switch cabinet

Panel supports for multipole connectors

size **44.27 – 104.27**

Specialized Applications



EN 60529	IP20
Ambient temperature limits	-40 °C ... +125 °C
Mechanical life (cycles)	≥ 500



CAIUS[®] ECBT2.E115072 | ECBT8.E115072

Item	Description	Part No.	Dimension
------	-------------	----------	-----------

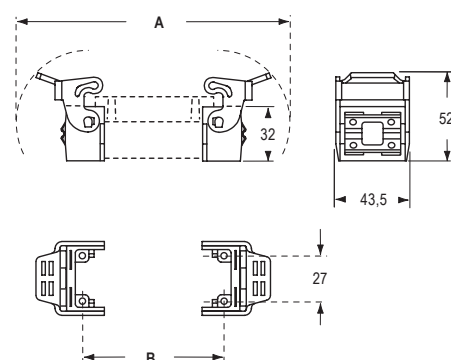


Connector carrier for faceplate mounting in window, snap fastening

[COB TCQ](#)

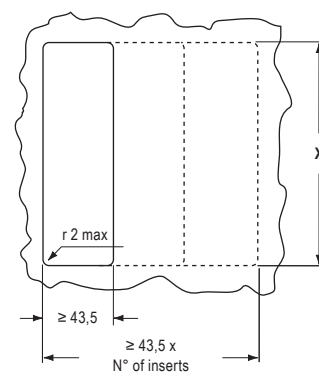
- kit with 2 elements, for coupling of inserts with screw fixing centre distance (short side = 27 mm)

Note:
It is the responsibility of the installer to verify the continuity of the PE protective earth circuit Ⓢ between the two halves of the connector.



Inserts size	A	B
44.27	120	44
57.27	133	57
77.27	153,5	77,5
104.27	180	104

Panel cut-out **COB TCQ**
window size on plate thickness 1,3-3 mm



Inserts coupling size	X _{±0,5}
44.27	44
57.27	57
77.27	77,5
104.27	104

COB

E

Inserts size 44.27 – 104.27	Poles	Pages	Inserts size 44.27 – 104.27	Poles	Pages
CNE 16 A	6 to 24 + Ⓢ	B.38-41	CSS 16 A	6 to 24 + Ⓢ	B.118-121
CCE 16 A	6 to 24 + Ⓢ	B.44-47	CMCE / CMSH 16 A	3 + 2 (aux.), 6 + 2 (aux.), 10 + 2 (aux.) + Ⓢ	B.144-146, 149-151
CSH / JSH S 16 A	6 to 24 + Ⓢ	B.52-55,58-61	CX / CXC	combined inserts	B.156-171
CSHT 16 A	10 to 24 + Ⓢ	B.66-68			
CQE / CQEY 16 A	10 to 46 + Ⓢ	B.72-75,82-85			
CQEE 16 A	40 to 64 + Ⓢ	B.78-79			
CD 10 A	40 to 64 + Ⓢ	B.90-91			
CDD 10 A	24 to 108 + Ⓢ	B.94-97			
CDSH / CDSH NC 10 A	9 to 42 + Ⓢ	B.102-105,108			
CP / CPY 35 A	6 + Ⓢ	B.112,114			

MIXO Modular Inserts	Pages
MIXO modules	C.12-93
CX T (2 to 6-slot sized MIXO frames)	C.95

Accessories:



CR .. BPE
PE jumpers
Page E.292



COB L
Levers
Page E.292

COB series – System for switch cabinet

Panel supports for multipole connectors

size 44.27 – 104.27


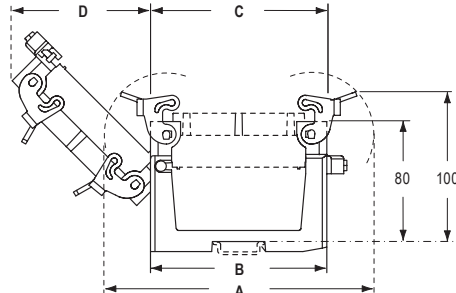
Specialized
Applications

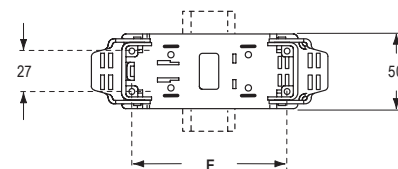


EN 60529	IP20
Ambient temperature limits	-40 °C ... +125 °C
Mechanical life (cycles)	≥ 500

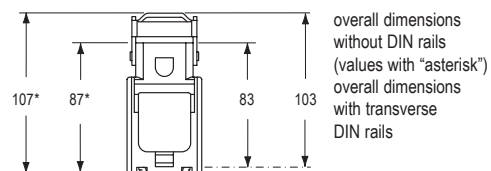


CAIUS® ECBT2.E115072 | ECBT8.E115072

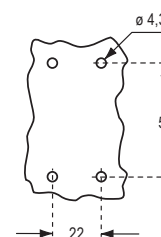
Item	Description	Inserts size	Part No.	Dimension
	Connector carrier baseplate for mounting on DIN EN 60715 rail or fixed mounting using screws - kit comprising frame and mobile blocks, for insert coupling Note: It is the responsibility of the installer to verify the continuity of the PE protective earth circuit ⊕ between the two halves of the connector.	44.27	COB 06 BC	
		57.27	COB 10 BC	
		77.27	COB 16 BC	
		104.27	COB 24 BC	



Part No.	A	B	C	D	E
44.27	120	91,5	58	50	44
57.27	133	91,5	71	59,5	57
77.27	153,5	91,5	91,5	74	77,5
104.27	180	118	118	93	104



Panel cut-out **COB BC**



Inserts size 44.27 – 104.27	Poles	Pages	Inserts size 44.27 – 104.27	Poles	Pages
CNE	16 A	6 to 24 + ⊕ B.38-41	CSS	16 A	6 to 24 + ⊕ B.118-121
CCE	16 A	6 to 24 + ⊕ B.44-47	CMCE / CMSH	16 A	3 + 2 (aux.), 6 + 2 (aux.), 10 + 2 (aux.) + ⊕ B.144-146, 149-151
CSH / JSH S	16 A	6 to 24 + ⊕ B.52-55,58-61	CX / CXC	combined inserts	B.156-171
CSHT	16 A	10 to 24 + ⊕ B.66-68			
CQE / CQEY	16 A	10 to 46 + ⊕ B.72-75,82-85			
CQEE	16 A	40 to 64 + ⊕ B.78-79			
CD	10 A	40 to 64 + ⊕ B.90-91			
CDD	10 A	24 to 108 + ⊕ B.94-97			
CDSH / CDSH NC	10 A	9 to 42 + ⊕ B.102-105,108			
CP / CPY	35 A	6 + ⊕ B.112,114			

MIXO Modular Inserts	Pages
MIXO modules	C.12-93
CX T (2 to 6-slot sized MIXO frames)	C.95

Accessories:



CR..BPE
PE jumpers
Page E.292



COB L
Levers
Page E.292

COB series – System for switch cabinet

Panel supports for multipole connectors

size **44.27 – 104.27**


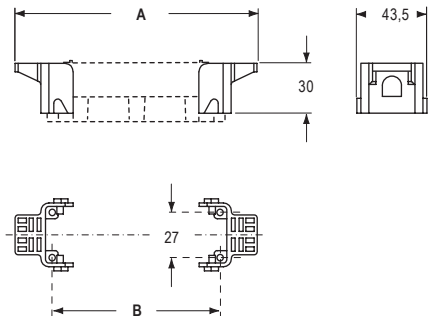
Specialized Applications


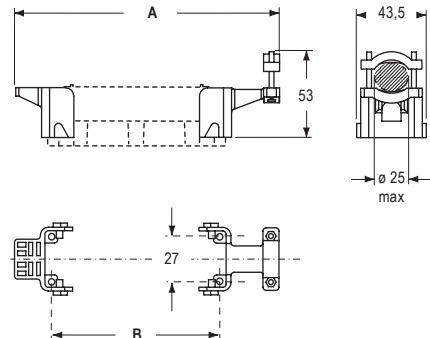


EN 60529	IP20
Ambient temperature limits	-40 °C ... +125 °C
Mechanical life (cycles)	≥ 500



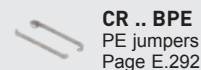
CAIUS[®] ECBT2.E115072 | ECBT8.E115072

Item	Description	Part No.	Entry	Dimension															
	Insert carrier blocks for mobile mounting with handle for cable support bands - kit with 2 elements, for coupling of inserts with screw fixing centre distance (short side = 27 mm)	COB TSF																	
	Note: It is the responsibility of the installer to verify the continuity of the PE protective earth circuit ⊕ between the two halves of the connector.																		
<table border="1"> <thead> <tr> <th>Inserts size</th> <th>A</th> <th>B</th> </tr> </thead> <tbody> <tr> <td>44.27</td> <td>90</td> <td>44</td> </tr> <tr> <td>57.27</td> <td>103</td> <td>57</td> </tr> <tr> <td>77.27</td> <td>123,5</td> <td>77,5</td> </tr> <tr> <td>104.27</td> <td>150</td> <td>104</td> </tr> </tbody> </table>					Inserts size	A	B	44.27	90	44	57.27	103	57	77.27	123,5	77,5	104.27	150	104
Inserts size	A	B																	
44.27	90	44																	
57.27	103	57																	
77.27	123,5	77,5																	
104.27	150	104																	

	Insert carrier blocks for mobile mounting with handle for cable support or cable clamp bands - kit with 2 elements, for coupling of inserts with screw fixing centre distance (short side = 27 mm)	COB TSFS																	
	Note: It is the responsibility of the installer to verify the continuity of the PE protective earth circuit ⊕ between the two halves of the connector.																		
<table border="1"> <thead> <tr> <th>Inserts size</th> <th>A</th> <th>B</th> </tr> </thead> <tbody> <tr> <td>44.27</td> <td>104</td> <td>44</td> </tr> <tr> <td>57.27</td> <td>117</td> <td>57</td> </tr> <tr> <td>77.27</td> <td>137,5</td> <td>77,5</td> </tr> <tr> <td>104.27</td> <td>164</td> <td>104</td> </tr> </tbody> </table>					Inserts size	A	B	44.27	104	44	57.27	117	57	77.27	137,5	77,5	104.27	164	104
Inserts size	A	B																	
44.27	104	44																	
57.27	117	57																	
77.27	137,5	77,5																	
104.27	164	104																	

Inserts size 44.27 – 104.27	Poles	Pages	Inserts size 44.27 – 104.27	Poles	Pages
CNE 16 A	6 to 24 + ⊕	B.38-41	CSS 16 A	6 to 24 + ⊕	B.118-121
CCE 16 A	6 to 24 + ⊕	B.44-47	CMCE / CMSH 16 A	3 + 2 (aux.),	B.144-146, 149-151
CSH / JSH S 16 A	6 to 24 + ⊕	B.52-55,58-61		6 + 2 (aux.),	
CSHT 16 A	10 to 24 + ⊕	B.66-68		10 + 2 (aux.) + ⊕	
CQE / CQEY 16 A	10 to 46 + ⊕	B.72-75,82-85	CX / CXC	combined inserts	B.156-171
CQEE 16 A	40 to 64 + ⊕	B.78-79	MIXO Modular Inserts		
CD 10 A	40 to 64 + ⊕	B.90-91	MIXO modules		C.12-93
CDD 10 A	24 to 108 + ⊕	B.94-97	CX T (2 to 6-slot sized MIXO frames)		C.95
CDSH / CDSH NC 10 A	9 to 42 + ⊕	B.102-105,108			
CP / CPY 35 A	6 + ⊕	B.112,114			

Accessories:



CR .. BPE
PE jumpers
Page E.292

COB series – System for switch cabinet

Panel supports for multipole connectors

size **49.16** and **66.16**


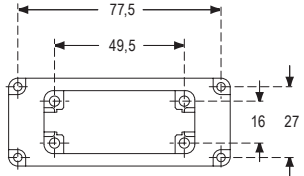

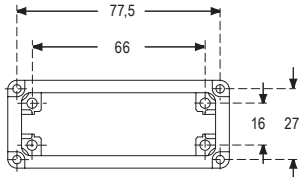
Specialized Applications



EN 60529	IP20
Ambient temperature limits	-40 °C ... +125 °C
Mechanical life (cycles)	≥ 500



CAIUS[®] ECBT2.E115072 | ECBT8.E115072

Item	Description	Part No.	Dimension
	<p>Adapter plates for insert mounting size 49.16</p> <p>Allows the mounting of inserts size 49.16 on the following COB series articles: COB TCQ, COB 16 BC, COB TSF, COB TSFS, COB 16 CMS</p> <p>Note: It is the responsibility of the installer to verify the continuity of the PE protective earth circuit ⊕ between the two halves of the connector.</p>	CR 15/16	
	<p>Adapter plates for insert mounting size 66.16</p> <p>Allows the mounting of inserts size 66.16 on the following COB series articles: COB TCQ, COB 16 BC, COB TSF, COB TSFS, COB 16 CMS</p> <p>Note: It is the responsibility of the installer to verify the continuity of the PE protective earth circuit ⊕ between the two halves of the connector.</p>	CR 25/16	

COB

E

Inserts size 49.16			Inserts size 66.16		
	Poles	Pages		Poles	Pages
CDA	16 A	10 + ⊕ B.16	CDA	16 A	16 + ⊕ B.17
CDC	16 A	10 + ⊕ B.19	CDC	16 A	16 + ⊕ B.20
CSAH	16 A	10 + ⊕ B.24	CSAH	16 A	16 + ⊕ B.25
CD	10 A	15 + ⊕ B.30	CD	10 A	25 + ⊕ B.31
			CDD	10 A	38 + ⊕ B.33

COB series – System for switch cabinet

size **21.21**

Panel supports for multipole connectors

Specialized
Applications

EN 60529	IP20
Ambient temperature limits	-40 °C ... +125 °C
Mechanical life (cycles)	≥ 500



CAIUS ECBT2.E115072 | ECBT8.E115072

Item	Description	Part No.	Dimension
------	-------------	----------	-----------



Connector carrier baseplate for mounting on DIN EN 60715 rail or fixed mounting using screws, for inserts coupling with inserts size 21.21

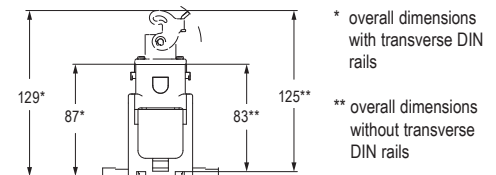
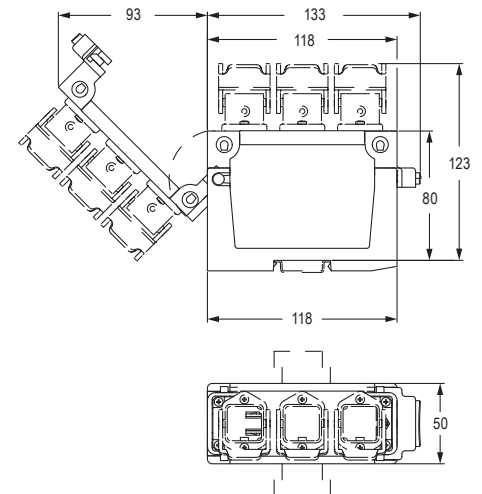
- kit comprising frame and mobile blocks, for insert coupling

Allows the mounting of up to 3 × 21.21 sized connector inserts, each one installed in relevant housings (either insulating type CK or metal type CKA with the preferred choice of locking lever, to be purchased separately) and fixed to the adapter plate by two self-tapping screws (6 in total, not provided).

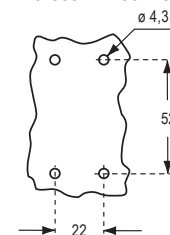
Note:

It is the responsibility of the installer to verify the continuity of the PE protective earth circuit ⊕ between the two halves of the connector.

[COB 03/3 BC](#)



Panel cut-out **COB 03/3 BC** for direct fixed mounting without DIN 60715 rails



COB

E



COB series


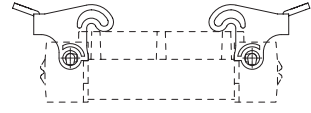
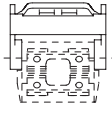
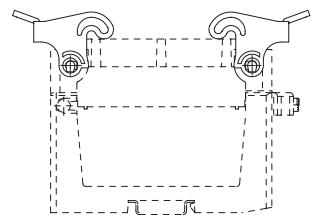
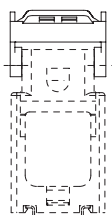
Accessories

size **44.27 – 104.27**

Specialized Applications

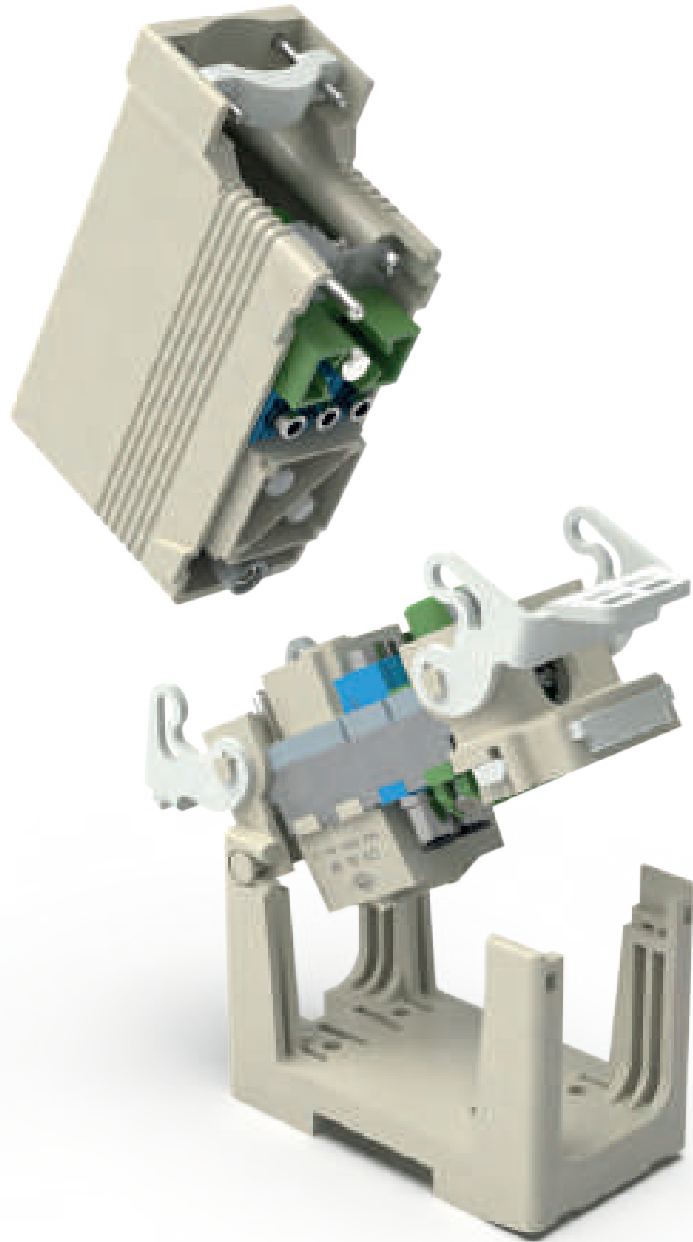


Item	Description	Insert size	Part No.	Dimension
	<p>PE jumpers in galvanized brass, to be optionally used with COB enclosures series</p> <p>CR...BPE accessories PE jumpers could be mounted under the connector inserts to guarantee proper PE connection.</p> <p>The jumpers are not usable individually. It is necessary to use <u>both</u> supplied jumpers (in the same housing or hood) in order to ensure the proper inserts alignment.</p> <p>Note: It is the responsibility of the installer to verify the continuity of the PE protective earth circuit Ⓢ between the two halves of the connector.</p>	44.27	CR 06 BPE	
		57.27	CR 10 BPE	
		77.27	CR 16 BPE	
		104.27	CR 24 BPE	

	<p>levers for coupling with metallic enclosures</p> <p>- kit with 2 elements, to be mounted instead of the standard levers to be coupled with: COB TCQ and COB...BC</p> <p>Allows the mounting of aluminium hoods with 4 pegs, size 57.27, 77.27 and 104.27</p>	<p>COB L</p>		
				

COB

E



E



LS-TYPE

On Stage



LS-TYPE Enclosures

The LS-TYPE enclosures are the ideal solution for the entertainment industry (lighting system power supply and related mixer and dimmer panels), including theatre stages, film sets, radio and TV studios, discos, trade fair booths, concert halls and night public events, indoors and outdoors.

All parts are in elegant RAL 9005 black, suitable for situations and locations where they should not be visible in the dark.

SUM-UP

- > Made of die cast aluminium alloy, powder-coated, jet black RAL 9005.
- > Gaskets in anti-aging, oil-resistant, grease-resistant and fuel resistant vinyl nitrile elastomer.
- > JEP-P locking device in self-extinguishing thermoplastic material.
- > Ambient temperature range: -40 °C / +125 °C.

≡ Markings and Approvals

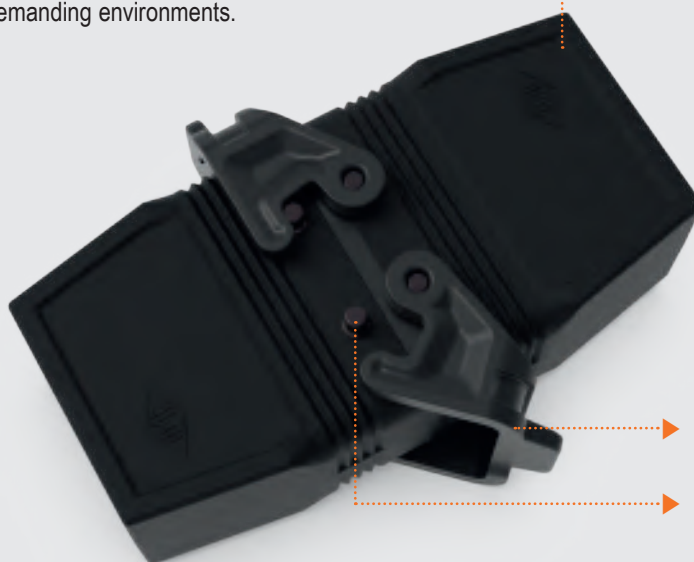
- CE and UK markings, EAC not applicable
- UL certified for USA and Canada for Type 12, 4 and 4X degrees of protection (enclosure type ratings, equivalent to NEMA rating)
- IP65 degree of protection
- RoHS: compliant

FOCUS

Locking lever in self-extinguishing thermoplastic material

Single-block locking lever in self-extinguishing thermoplastic material with enhanced ergonomics and reduced dimension, ideal for basic requirements and less demanding environments.

▶ Elegant RAL 9005 jet black coating, suitable for situations and locations where enclosures should not be visible in the dark.



▶ Thermoplastic lever

▶ Burnished pegs for a total black look

LS-TYPE series – Light and Sound

Housings, hoods and covers – 1 lever – with gasket


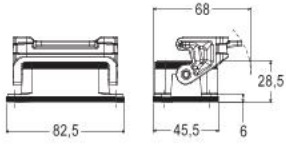

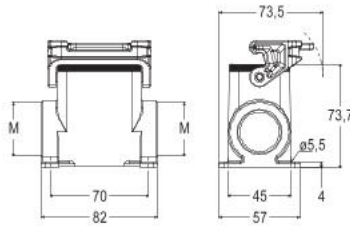

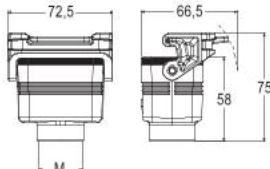

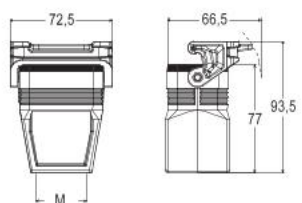


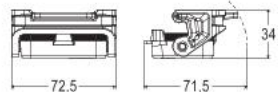
size **44.27**

Specialized Applications 

EN 60529	IP65
UL 50 / UL 50E	Type 12 / 4 / 4X
Ambient temperature limits	-40 °C ... +90 °C
Mechanical life (cycles)	≥ 500



ALUS ECBT2.E115072 | ECBT8.E115072

Item	Description	Part No.	Entry	Dimension
	Bulkhead mounting housings, 1 lever and gasket	CHIN 06 L		
	Surface mounting housings, 1 lever and gasket, high construction	MAPN 06 L32	M32	
	Hoods, 1 lever and gasket, top entry	MHVN 06 LG25	M25	
	Hoods, 1 lever and gasket, top entry, high construction To be used only with a complete cable gland	MFVN 06 LG25	M25	
	Covers, 1 lever and gasket For enclosures with 2 pegs without gasket with loop for hoods 	CHCN 06 LG		


LS-TYPE
E

Inserts size 44.27	Poles	Pages	MIXO Modular Inserts	Pages
CNE 16 A	6 + ⊕	3.38	MIXO modules	C.12-93
CCE 16 A	6 + ⊕	3.44	CX 02 T (2-slot sized MIXO frames)	C.95
CSH / JSH S	16 A	3.52		
CQE / CQEY	16 A	3.72		
CDD	10 A	3.94		
CDSH / CDSH NC	10 A	3.102		108
CSS	16 A	3.116		
CT / CTSE*	16 A	3.126		130

*can be used only in bulkhead mounting housings

LS-TYPE series – Light and Sound

Housings, hoods and covers – 2 pegs – without gasket


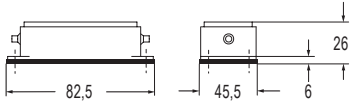

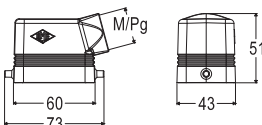

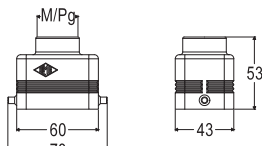

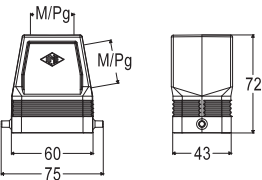

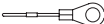
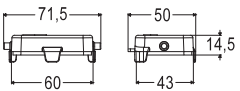
size **44.27**Specialized Applications 

CE UK



EN 60529	IP65
UL 50 / UL 50E	Type 12 / 4 / 4X
Ambient temperature limits	-40 °C ... +90 °C
Mechanical life (cycles)	≥ 500

 ECBT2.E115072 | ECBT8.E115072

Item	Description	Part No.	Entry	Dimension
	Bulkhead mounting housings, 2 pegs, without gasket	CHIN 06 LCH		
	Hoods, side entry, 2 pegs, without gasket	Side entry MHON 06 L25	M25	
	Hoods, top entry, 2 pegs, without gasket	Top entry MHVN 06 L25	M25	
	Hoods, side or top entry, 2 pegs, high construction, without gasket To be used only with a complete cable gland	Side entry MFON 06 L25 Top entry MFVN 06 L25	M25	
	Covers, 2 pegs, without gasket For enclosures with 1 lever and gasket with eyelet for housings 	CHCN 06 L		

Inserts size 44.27	Poles	Pages	MIXO Modular Inserts	Pages	
CNE	16 A	6 + ⊕	B.38	MIXO modules	C.12-93
CCE	16 A	6 + ⊕	B.44	CX 02 T (2-slot sized MIXO frames)	C.95
CSH / JSH S	16 A	6 + ⊕	B.52,58		
CQE / CQEY	16 A	10 + ⊕	B.72,82		
CDD	10 A	24 + ⊕	B.94		
CDSH / CDSH NC	10 A	9 and 6 + ⊕	B.102,108		
CSS	16 A	6 + ⊕	B.118		
CT / CTSE*	16 A	6 + ⊕	B.126,130		


*can be used only in bulkhead mounting housings

dimensions shown in mm are not binding and may be changed without notice

LS-TYPE series – Light and Sound

Housings, hoods and covers – 2 levers – with gasket


size **57.27**



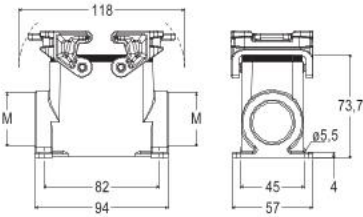

Specialized Applications 

CE UK CA

CEC DNV VERITAS

EN 60529	IP65
UL 50 / UL 50E	Type 12 / 4 / 4X
Ambient temperature limits	-40 °C ... +90 °C
Mechanical life (cycles)	≥ 500

 ECBT2.E115072 | ECBT8.E115072

Item	Description	Part No.	Entry	Dimension
	Bulkhead mounting housings, 2 levers and gasket	CHIN 10		
	Surface mounting housings, 2 levers and gasket, high construction	MAPN 10.32	M32	
	Hoods, 2 levers and gasket, top entry	MHVN 10 G25	M25	
	Hoods, 2 levers and gasket, top entry, high construction To be used only with a complete cable gland	MFVN 10 G220 MFVN 10 G32	M20 x 2 M32	
	Covers, 2 levers and gasket For enclosures with 4 pegs without gasket with loop for hoods 	CHCN 10 G		

Inserts size 57.27	Poles	Pages	Inserts size 57.27	Poles	Pages
CNE	16 A	10 + ☉	CT / CTSE*	16 A	10 + ☉
CCE	16 A	10 + ☉	CMCE / CMSH	16 A	3 + 2 (aux.) + ☉
CSH / JSH S	16 A	10 + ☉	CX	40 A/10 A	8/24 + ☉
CSHT	16 A	10 + ☉	*can be used only in bulkhead mounting housings		
CQE / CQEY	16 A	18 + ☉	MIXO Modular Inserts		
CDD	10 A	42 + ☉	MIXO modules		
CDSH	10 A	18 + ☉	CX 03 T (3-slot sized MIXO frames)		
CSS	16 A	10 + ☉			

LS-TYPE series – Light and Sound

Housings, hoods and covers – 4 pegs – without gasket

size **57.27**

Specialized Applications



CE UK



EN 60529	IP65
UL 50 / UL 50E	Type 12 / 4 / 4X
Ambient temperature limits	-40 °C ... +90 °C
Mechanical life (cycles)	≥ 500

ECBT2.E115072 | ECBT8.E115072


Item	Description	Part No.	Entry	Dimension
	Bulkhead mounting housings, 4 pegs, without gasket	CHIN 10 CH		
	Hoods, side entry, 4 pegs, without gasket	Side entry MHON 10.25	M25	
	Hoods, top entry, 4 pegs, without gasket	Top entry MHVN 10.25	M25	
	Hoods, side or top entry, 4 pegs, high construction, without gasket To be used only with a complete cable gland	Side entry MFON 10.32 Top entry MFVN 10.32	M32	
	Covers, 4 pegs, without gasket For enclosures with 2 levers and gasket with eyelet for housings 	CHCN 10		

Inserts size 57.27	Poles	Pages	Inserts size 57.27	Poles	Pages		
CNE	16 A	10 + ⊕	B.39	CT / CTSE*	16 A	10 + ⊕	B.127,131
CCE	16 A	10 + ⊕	B.45	CMCE / CMSH	16 A	3 + 2 (aux.) + ⊕	B.144,149
CSH / JSH S	16 A	10 + ⊕	B.53,59	CX	40 A/10 A	8/24 + ⊕	B.170-171
CSHT	16 A	10 + ⊕	B.66	*can be used only in bulkhead mounting housings			
CQE / CQEY	16 A	18 + ⊕	B.73,83				
CDD	10 A	42 + ⊕	B.95	MIXO Modular Inserts			
CDSH	10 A	18 + ⊕	B.103	MIXO modules			
CSS	16 A	10 + ⊕	B.119	CX 03 T (3-slot sized MIXO frames)			
			Pages				
			C.12-93				
			C.95				

LS-TYPE series – Light and Sound

Housings, hoods and covers – 2 levers – with gasket


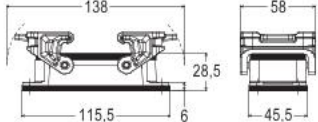

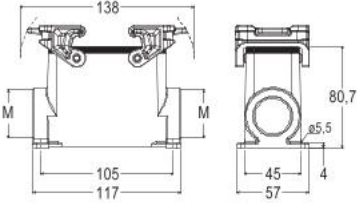

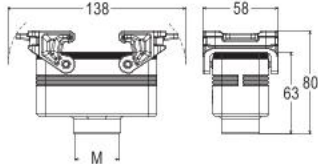

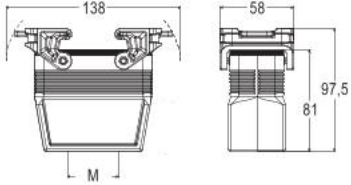


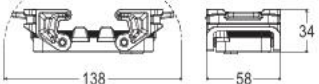
size **77.27**

Specialized Applications 

EN 60529	IP65
UL 50 / UL 50E	Type 12 / 4 / 4X
Ambient temperature limits	-40 °C ... +90 °C
Mechanical life (cycles)	≥ 500



ALUS ECBT2.E115072 | ECBT8.E115072

Item	Description	Part No.	Entry	Dimension
	Bulkhead mounting housings, 2 levers and gasket	CHIN 16		
	Surface mounting housings, 2 levers and gasket, high construction	MAPN 16.32	M32	
	Hoods, 2 levers and gasket, top entry	MHVN 16 G32	M32	
	Hoods, 2 levers and gasket, top entry, high construction To be used only with a complete cable gland	MFVN 16 G225 MFVN 16 G32	M25 x 2 M32	
	Covers, 2 levers and gasket For enclosures with 4 pegs without gasket with loop for hoods 	CHCN 16 G		

Inserts size 77.27	Poles	Pages	Inserts size 77.27	Poles	Pages	MIXO Modular Inserts	Pages
CNE	16 A	16 + ⊕	CP / CPY	35 A	6 + ⊕	MIXO modules	C.12-93
CCE	16 A	16 + ⊕	CSS	16 A	16 + ⊕	CX 04 T (4-slot sized MIXO frames)	C.93
CSH / JSH S	16 A	16 + ⊕	CT / CTSE*	16 A	16 + ⊕		
CSHT	16 A	16 + ⊕	CT / CTS*	10 A	40 + ⊕		
CQE / CQEY	16 A	32 + ⊕	CMCE / CMSH	16 A	6 + 2 (aux.) + ⊕		
CQEE	16 A	40 + ⊕	CX / CXC	80 A/16 A	4/0, 4/2 + ⊕		
CD	10 A	40 + ⊕	CX	40 A/10 A	6/12, 6/36, 9/42 and 12/2 + ⊕		
CDD	10 A	72 + ⊕					
CDSH	10 A	27 + ⊕					

*can be used only in bulkhead mounting housings

LS-TYPE series – Light and Sound

Housings, hoods and covers – 4 pegs – without gasket


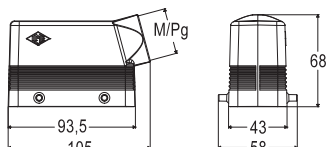
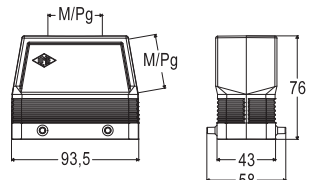
size **77.27**Specialized
Applications

CE UK



EN 60529	IP65
UL 50 / UL 50E	Type 12 / 4 / 4X
Ambient temperature limits	-40 °C ... +90 °C
Mechanical life (cycles)	≥ 500

ECBT2.E115072 | ECBT8.E115072

Item	Description	Part No.	Entry	Dimension
	Bulkhead mounting housings, 4 pegs, without gasket	CHIN 16 CH		
	Hoods, side entry, 4 pegs, without gasket	Side entry MHON 16.32	M32	
	Hoods, top entry, 4 pegs, without gasket	Top entry MHVN 16.32	M32	
	Hoods, side or top entry, 4 pegs, high construction, without gasket To be used only with a complete cable gland	Side entry MFON 16.32 Top entry MFVN 16.32	M32	
	Covers, 4 pegs, without gasket For enclosures with 2 levers and gasket with eyelet for housings 	CHCN 16		

LS-TYPE

E

Inserts size 77.27	Poles	Pages	Inserts size 77.27	Poles	Pages	MIXO Modular Inserts	Pages
CNE	16 A	16 + ⊕ B.40	CP / CPY	35 A	6 + ⊕	B.112,114	
CCE	16 A	16 + ⊕ B.46	CSS	16 A	16 + ⊕	B.120	C.12-93
CSH / JSH S	16 A	16 + ⊕ B.54,60	CT / CTSE*	16 A	16 + ⊕	B.128,132	C.95
CSHT	16 A	16 + ⊕ B.67	CT / CTS*	10 A	40 + ⊕	B.138,140	
CQE / CQEY	16 A	32 + ⊕ B.74,84	CMCE / CMSH	16 A	6 + 2 (aux.) + ⊕	B.145,150	
CQEE	16 A	40 + ⊕ B.78	CX / CXC	80 A/16 A	4/0, 4/2 + ⊕	B.158-160	
CD	10 A	40 + ⊕ B.90	CX	40 A/10 A	6/12, 6/36, 9/42 and 12/2 + ⊕	B.163-164, 168-169	
CDD	10 A	72 + ⊕ B.94					
CDSH	10 A	27 + ⊕ B.104	*can be used only in bulkhead mounting housings				


dimensions shown in mm are not binding and may be changed without notice

E.301

LS-TYPE series – Light and Sound

Housings, hoods and covers – 2 levers – with gasket

size **104.27**


Specialized Applications 

CE UK CA

CEC DNV VERITAS

EN 60529	IP65
UL 50 / UL 50E	Type 12 / 4 / 4X
Ambient temperature limits	-40 °C ... +90 °C
Mechanical life (cycles)	≥ 500


ALUS ECBT2.E115072 | ECBT8.E115072

Item	Description	Part No.	Entry	Dimension
	Bulkhead mounting housings, 2 levers and gasket	CHIN 24		
	Surface mounting housings, 2 levers and gasket, high construction	MAPN 24.32	M32	
	Hoods, 2 levers and gasket, top entry	MHVN 24 G32	M32	
	Hoods, 2 levers and gasket, top entry, high construction To be used only with a complete cable gland	MFVN 24 G32 MFVN 24 G232	M32 M32 x 2	
	Covers, 2 levers and gasket For enclosures with 4 pegs without gasket with loop for hoods 	CHCN 24 G		

Inserts size 104.27	Poles	Pages	Inserts size 104.27	Poles	Pages	MIXO Modular Inserts	Pages
CNE	16 A	24 + ⊕	3.41	CSS	16 A	24 + ⊕	3.12
CCE	16 A	24 + ⊕	3.47	CT / CTSE*	16 A	24 + ⊕	3.129-133
CSH / JSH S	16 A	24 + ⊕	3.55-57	CT / CTS*	10 A	64 + ⊕	3.139-141
CSHT	16 A	24 + ⊕	3.68	CMCE / CMSH	16 A	10 + 2 (aux.) + ⊕	3.146-151
CQE / CQEY	16 A	46 + ⊕	3.75-38	CX	100 A/16 A	8/0 and 6/6 + ⊕	3.156-157
CQEE	16 A	64 + ⊕	3.79	CX / CXC	80 A/16 A	4/8 + ⊕	3.161-162
CD	10 A	64 + ⊕	3.91	*can be used only in bulkhead mounting housings			
CDD	10 A	108 + ⊕	3.97				
CDSH	10 A	42 + ⊕	3.103				
						MIXO modules	3.12-93
						CX 06 T (6-slot sized MIXO frames)	3.93

LS-TYPE series – Light and Sound

Housings, hoods and covers – 4 pegs – without gasket

size **104.27**Specialized Applications 

CE UK



EN 60529	IP65
UL 50 / UL 50E	Type 12 / 4 / 4X
Ambient temperature limits	-40 °C ... +90 °C
Mechanical life (cycles)	≥ 500

 ECBT2.E115072 | ECBT8.E115072

Item	Description	Part No.	Entry	Dimension
	Bulkhead mounting housings, 4 pegs, without gasket	CHIN 24 CH		
	Hoods, side entry, 4 pegs, without gasket	Side entry MHON 24.32	M32	
	Hoods, top entry, 4 pegs, without gasket	Top entry MHVN 24.32	M32	
	Hoods, side or top entry, 4 pegs, high construction, without gasket To be used only with a complete cable gland	Side entry MFON 24.32 Top entry MFVN 24.32	M32	
	Covers, 4 pegs, without gasket For enclosures with 2 levers and gasket with eyelet for housings 	CHCN 24		

Inserts size 104.27	Poles	Pages	Inserts size 104.27	Poles	Pages	MIXO Modular Inserts	Pages
CNE	16 A	24 + ⊕	B.41	CSS	16 A	24 + ⊕	B.121
CCE	16 A	24 + ⊕	B.47	CT / CTSE*	16 A	24 + ⊕	B.129,133
CSH / JSH S	16 A	24 + ⊕	B.55,61	CT / CTS*	10 A	64 + ⊕	B.139,141
CSHT	16 A	24 + ⊕	B.68	CMCE / CMSH	16 A	10 + 2 (aux.) + ⊕	B.146,151
CQE / CQEY	16 A	46 + ⊕	B.75,85	CX	100 A/16 A	8/0 and 6/6 + ⊕	B.156-157
CQEE	16 A	64 + ⊕	B.79	CX / CXC	80 A/16 A	4/8 + ⊕	B.161-162
CD	10 A	64 + ⊕	B.91	*can be used only in bulkhead mounting housings			
CDD	10 A	108 + ⊕	B.97				
CDSH	10 A	42 + ⊕	B.105				

Panel cut-out drawings

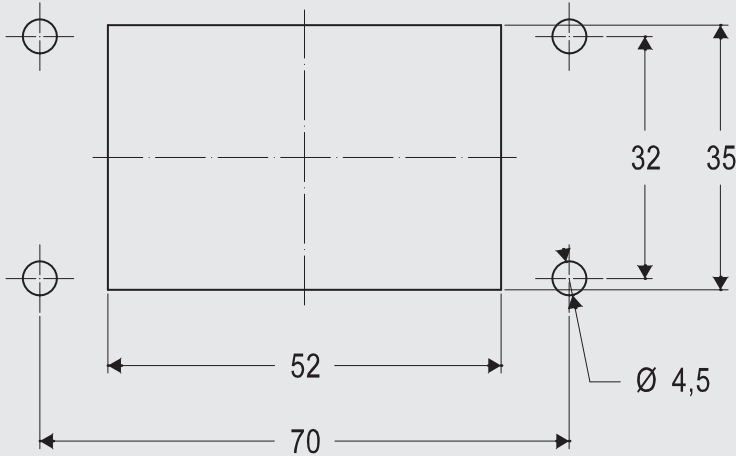
For LS-TYPE series bulkhead mounting housings

To guarantee the declared IP degree of protection of the housings reported in this catalogue, according to EN IEC 60529 or to the relevant Type rating per ANSI/UL 50 and 50E (for those products bearing approval to those ratings), the surface of the mounting panel must meet the following requirements (definitions are provided in ISO 4287 standard):

Waviness $Wt \leq 0,2$ mm over a distance of 200 mm (measured on the panel without load)
Roughness $Ra \leq 16$ μ m

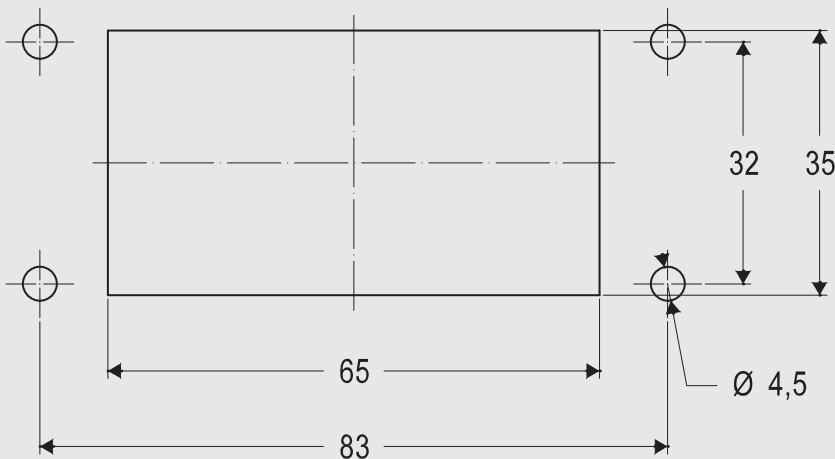
Scale 1:1

Size 44.27



Required screws: 4
Screws size: M4
Recommended size:
 0,8 – 1,2 Nm / 7.1 – 10.6 lb.in

Size 57.27



Required screws: 4
Screws size: M4
Recommended size:
 0,8 – 1,2 Nm / 7.1 – 10.6 lb.in

Notes: The values of tightening torque indicated above are just recommended values, that must be related – by the designer of the final application – to the resistance class of the screws (not included), with the assumption that the mounting panel is sufficiently rigid (stiff). If the deflection of the panel, under the effect of tightening the screws, is greater than 0,7 mm over a distance of 100 mm, it is

necessary to use the counter-flanges mentioned in our catalogue or the special flange gaskets available upon request (please contact our Sales Department).

Panel cut-out drawings

For LS-TYPE series bulkhead mounting housings

To guarantee the declared IP degree of protection of the housings reported in this catalogue, according to EN IEC 60529 or to the relevant Type rating per ANSI/UL 50 and 50E (for those products bearing approval to those ratings), the surface of the mounting panel must meet the following requirements (definitions are provided in ISO 4287 standard):

Waviness $Wt \leq 0,2$ mm over a distance of 200 mm
(measured on the panel without load)

Roughness $Ra \leq 16$ μ m

Scale 1:1

Size 77.27



Required screws: 4
Screws size: M4
Recommended size:
0,8 – 1,2 Nm / 7.1 – 10.6 lb.in

Size 104.27



Required screws: 4
Screws size: M4
Recommended size:
0,8 – 1,2 Nm / 7.1 – 10.6 lb.in

Notes: The values of tightening torque indicated above are just recommended values, that must be related – by the designer of the final application – to the resistance class of the screws (not included), with the assumption that the mounting panel is sufficiently rigid (stiff). If the deflection of the panel, under the effect of tightening the screws, is greater than 0,7 mm over a distance of 100 mm, it is











necessary to use the counter-flanges mentioned in our catalogue or the special flange gaskets available upon request (please contact our Sales Department).

GENERAL CATALOGUE

Crimp contacts

See Tools from page F.23

Contents

Contacts	The crimping concept	F.2
Machined series	C30	
	- 300 A silver plated	F.6
	CY	
	- 200 A silver plated	F.7
	CG	
	- 100 A silver plated	F.8
	CX7 / RX7 HNM	
	- 80 A / 70 A silver / HNM gold plated	F.9
	CX / RX HNM	
	- 40 A silver / HNM gold plated	F.10
	CC / RC HNM	
	- 16 A silver / gold / HNM gold plated	F.11
	- 16 A tin plated	F.12
	- 16 A high thickness and basic	F.13
	CD / RD HNM	
	- 10 A silver / gold / HNM gold plated	F.14
	- 10 A tin plated	F.15
	- 10 A high thickness and basic	F.16
	CI / RI HNM	
	- 5 A silver / gold / HNM gold plated	F.17
	- 5 A high thickness and basic	F.17
Stamped series	SD / SI	
	- 10 A silver plated	F.18
	- 5 A selective gold plated	F.19
Special Contacts	Thermocouples Type J (Fe-CuNi)	F.20
	POF Fibre Optic	F.21

THE CRIMPING CONCEPT

The crimped connection is an irreversible, non-reusable connection between one or two conductors and a crimp contact. It is obtained by compression deformation (cold forming) and consequent reshaping of the contact crimping stem, or crimp barrel. A good crimped connection is provided by a suitable combination between the crimping dies, the contact crimp barrel (hence the crimp contact), and the cross-sectional area of the conductor.

These considerations refer to crimped connections made with flexible copper conductors of class 5 (flexible) or 6 (more flexible than class 5) according to EN IEC 60228 standard.

Solid copper conductors (class 1) or conductors made by other materials (aluminium, iron, etc.) often require special precautions for both crimp contacts and crimping tools, to be agreed upon with the manufacturer.

The main technical advantages provided by crimped connections over soldered connections are:

- Independence from temperature, being this a "cold" process, performed without using heat and not requiring further materials.
- Elimination of the contact uncertainties due to cold solders.
- No degradation of the elastic characteristics of the female contacts (a problem that arises with soldering temperatures).
- No health risks connected with the use of heavy metals or fumes generated from the soldering process.
- Preservation of the conductor's flexibility immediately beyond connection.
- No conductors with burned, discoloured or overheated insulating material.
- Excellent reproducibility of the performances of the electrical and mechanical connections.
- Easier production controls.

Other advantages obtained by crimping connections over screw-type connections are:

- Lower voltage drop across the connection.
- High stability in time even in the presence of vibrations.
- High durability in presence of corrosion (gas-tightness).
- Individual insertion of the contacts in the connector (it is possible to eliminate unnecessary contacts).
- Less time required for connection.
- Possibility of pre-production of the terminated conductors with crimp contacts.
- Easy replacement of individual contacts during maintenance.
- Possibility of selectively isolating the circuits during maintenance via the extraction of the contacts from the connector.

The crimped connections for wire sections up to 10 mm² are covered by the EN 60352-2:2006 European standard equivalent to the IEC 60352-2 Issue 2 (2006-02) international standard.

The **EN 60352-2** standard also includes a practical guidance, which lists the following main points.

The quality of a crimped connection is mainly affected by the quality of the materials used and by the condition of the surfaces both of the crimp contact (in particular the crimp barrel) and of the conductor.

To ensure a good quality crimped connection, an essential parameter is the mechanical retention of the conductor in the contact.

The standard makes a distinction between the closed crimp barrel, inherently stronger, and the open crimp barrel. ILME crimp contacts are closed crimp barrel contacts, with inspection hole which ensure a higher mechanical performance compared to the open barrel crimp contacts, such as better mechanical robustness and stability during operation. They have been high speed precision-machined, thus ensuring a better electrical performance (better conductivity).

In 2002 the Amendment 2 of the previous IEC standard had controversially unified the minimum tensile strength for open crimp barrel contacts (curve B of former Figure 5) and closed crimp barrel contacts (curve A of former

Figure 5) making them both equal to the lower values (those of curve B), which can be achieved by open barrel crimp contacts. This change has determined an arguable relaxation of the suitability requirements both for closed crimp barrel, typically larger, machine turned and for crimping tools specially made for these contacts. Several industries continue to prefer the higher performance ensured by closed crimp barrel contacts, the only ones able to ensure the higher resistance to tensile stress values believed to be essential for the most demanding industrial applications.

Therefore, ILME continues to refer to curve A of Figure 5 illustrated in the EN 60352-2:1994 standard: ILME closed crimp barrel contacts, used with flexible copper wires, featuring a cross-sectional area included in the ranges shown and correctly crimped with the recommended tools, ensure tensile breaking resistant connections at least equal to the values shown in the table below (for reference, the corresponding R_t/S unified tensile stress load value is also shown [N/mm]). See Table 1 below.

Section S		Resistance to traction R _t (N)	R _t /S (N/mm ²)
AWG	mm ²		
26	0,12	18	150
–	0,14	21	150
24	0,22	33	150
–	0,25	37,5	150
22	0,32	48	150
–	0,37	55,5	150
20	(0,6)	75	150
–	0,75	112,5	150
18	(0,82)	125	150
–	1	150	150
16	(1,3)	195	150
–	1,5	220	147
14	(2,1)	300	143
–	2,5	325	130
12	(3,3)	430	130
–	4	500	125
10	(5,3)	635	120
–	6	650	108
7	10	1 000	100
6	(13,3)	1 330	100
–	16	1 600	100
4	(21,2)	1 700	80
–	25	2 000	80
3	(26,7)	2 140	80
–	35	2 800	80
2	(33,6)	2 690	80
–	50	3 000	60
1/0	(53,5)	3 210	60
2/0	(67,4)	4 040	60
–	70	4 200	60
3/0	(85)	5 100	60
–	95	5 700	60
4/0	(107)	6 420	60
–	120	7 200	60
250	(127)	7 620	60
–	150	9 000	60
300	(156)	9 360	60
350	(177)	10 620	60
–	185	11 100	60
400	(203)	12 180	60
–	240	14 400	60

Table 1.

The basic criterion used for the tensile strength values required by EN 60352-2 standard is that such resistance is at least equal to 60% of the per unit breaking load of the same annealed copper conductor. This applies to conductor cross-sectional areas up to about 1,5 mm²; above this cross-section, the ratio is slightly lower, as retention is also affected by friction, which increases linearly with the housing diameter, whilst the cross-section increases by the square.

IEC/EN 60352-2 standard, which historically targeted the electronics industry, restricts its requirements to crimp connections for conductors with a maximum cross-sectional area of 10 mm². For cross-sectional areas higher than 10 mm², up to 70 mm² the reference standard has been the NF F 61-030:1989 French standard until its withdrawal in favour of EN 50467:2011, which relates to electrical connectors on board railway rolling stock.

For large size crimp contacts, such as those manufactured by ILME, a possible reference is provided by EN 50343:2014, Railway applications – Rolling stock – Rules for installation of cabling, later converted into IEC 62995:2018, that in Annex G (informative) provides tensile test values based on IEC 61238-1-1:2018, Compression and mechanical connectors for power cables – Part 1-1: Test methods and requirements for compression and mechanical connectors for power cables for rated voltages up to 1 kV (Um = 1,2 kV) tested on non-insulated conductors. This is the basis for a forthcoming standardization project for large size crimped connection currently under development in IEC SC 48B.






Crimp contacts identification

MIXO 300 A max contacts

Conductor section		Identification
mm ²	AWG	slot Ø (mm)
16	6	5,5
25	4	7,0
35	2	8,2
50	1	10
70	2/0	11,5
95	3/0	13,5
120	4/0	15,5

☑ Contacts supplied in silver plated version only

MIXO 200 A max contacts

Conductor section		Identification	Groove Identification
mm ²	AWG	slot Ø (mm)	
16	6	6,1	
25	4	7,0	
35	2	8,2	
50	1	9,8	
70	2/0	11,8	

☑ Contacts supplied in silver plated version only

MIXO 70 A (80 A) / 100 A max contacts









Conductor section		Identification
mm ²	AWG	slot Ø (mm)
6	10	3,5
8 – 10	8 – 7	4,3
16	6 – 5	5,5
16 (XF)	6 – 5	6,1
25	4 – 3	7,0
35	2	7,9 / 8,2

40 A max contacts

Conductor section		Identification
(mm ²)	AWG	slot Ø (mm)
1,5	16	1,75
2,5	14	2,25
4	12	2,85
6	10	3,5
10	8	4,3







☑ MIXO above contacts are supplied in the silver plated version only

16 A max contacts

Conductor section		Groove Identification
mm ²	AWG	
0,14 - 0,37	26 - 22	
0,5	20	
0,75	18	
1	18	
1,5	16	
2,5	14	
3	12	
4	12	





☑ Contacts supplied in both silver /gold plated versions. Male contacts can also be supplied in the "advanced" version and iron/constantan contacts for thermocouples J type.

10 A max contacts

Conductor section		Number Identification
mm ²	AWG	
0,14 - 0,37	26 - 22	
0,5	20	
0,75	18	
1	18	
1,5	16	
2,5	14	

☑ Contacts supplied in both silver/gold plated versions

4 A / 5 A / 6,5 A max contacts

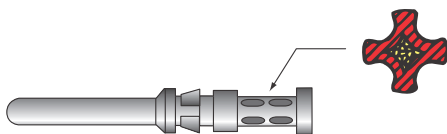
Conductor section		Identification	Groove Identification
mm ²	AWG		
0,08 - 0,21	28 - 24	0,64 mm	
0,13 - 0,33	26 - 22	0,90 mm	
0,33 - 0,52	22 - 20	1,12 mm	
0,52 - 0,75	20 - 18	1,3 mm	

SELECTING THE CRIMPING TOOL AND RELEVANT CONTROLS

When you have selected quality crimp contacts and conductors, the next and most important step is to select the correct crimp tool. The practical guidance of standard EN 60352-2 provides the following recommendations on the subject, listing some of the ideal requirements for crimping tools, some optional characteristics, but, above all, it provides a preview of the indispensable controls:

- a) The crimping tools and the contacts used shall be supplied by the same manufacturer, otherwise the user shall assume all responsibility for the quality and reliability of the crimp connections.
- b) The crimping tools must function correctly and provide a correct crimp without damage to the pin or the component to crimp.
- c) In order to obtain a reliable crimp connection, a crimping device with a mechanism that controls the entire crimping cycle shall be used. At the end of the crimping cycle the handles and the ratchet must return to the open position.
- d) In all cases the crimping operation shall be made in one single phase, with no further interventions.
- e) The removable parts of the tool such as the crimping dies and the locators must be designed in such a way as to make it possible to be inserted within the tool only in the correct manner.
- f) The tools must be supplied with the appropriate means for a correct positioning of the pins to be crimped and of the conductors during crimping.
- g) The tools must be designed in such a way so that only the necessary adjustments may be made.
- h) The action of the tool must be such that both the pin to be crimped and the fixture of the isolation (when present) are respectively crimped or compressed with a single action.
- i) The design of the tool must ensure that the dies for a particular tool may be interchangeable within tools of the same type. If they are not interchangeable, the identification of tools for which they are suitable must be marked on the dies.
- j) The tools may be designed so as to produce a marking or coding of the die on the pin to be crimped so that the crimping may be checked for verification of the correct die.
- k) The design of the tool must allow the verification of the dies with gauges to measure wear. The gauge verification method must be that specified by the manufacturer of the tools.

With suitable flexible copper conductors, the crimping tool proposed by ILME gives 8-indent crimping (see figure) in conformity with standard EN 60352-2. Periodic control of the wear of the crimping dies can be carried out with the appropriate "go – no go" gauges (to be purchased separately). For extra operational details, consult the following pages on tools, and the relevant instruction sheets and/or use and maintenance manuals.



The manual and automatic crimping tools selected by ILME are carefully designed to ensure symmetrical deformation of the crimping area of the contact and wire, by means of their own, internal high pressure forming parts. The positioner ensures that the wire and crimp contact meet in the appropriate part of the tool. Sprung mechanisms built into the tools ensure that the contacts are not inserted in the tool before the indenters are fully open, and that the tool does not open before the crimping process has been completed.

The **CIPZ D** (for 5A crimp contacts), **CCPZ MIL** (for 10A and 16A crimp contacts) and **CXPZ D** (for 40A crimp contacts) manual crimping tools are suitable for use when compressed air sources are unavailable, for low or medium-low workloads.

The **CCPZ RN** (for 10A, 16A and 40A crimp contacts) manual crimping tool is also suitable for low or medium-low workloads.

All the above tools provide 8-indent crimping.

The **CCPZ TP** (for 10A and 16A crimp contacts) and **CXPZ TP** (for 40A crimp contacts) manual crimping tools are also suitable for low or medium-low workloads and provide a "square shaped" crimping cross-section. Crimped connections produced by these tools are in compliance with the requirements of EN 60352-2.

The **CCPZP** pneumatic crimping bench tool without automatic positioner (for 10A and 16A crimp contacts) is suitable for use in the workshop (where compressed air is available) for high or medium-high workloads. Using the same manual crimping tool turrets, it is possible to change rapidly from crimping on male contacts to crimping on female contacts of the same series (10A and 16A).

The **CCPZPA** pneumatic crimping bench tool with automatic positioner (for 10A and 16A crimp contacts) is suitable for workshop jobs (where compressed air is available) for medium-high or high workloads. It is recommended in particular for crimping high quantities of contacts that are the same type or have the same section, thus saving a significant amount of time thanks to automatic operation and reduced operator fatigue. Where the type or kind of contact must be changed frequently, it is preferred to use the version without automatic positioner.

The **CXPZP D** pneumatic crimping bench tool without automatic positioner (for 40A crimp contacts) is suitable for use in the workshop (where compressed air is available) for high or medium-high workloads. By using the same positioners as those of manual crimper CXPZ D, the size of a contact can be rapidly changed with one of the same type.

The semiautomatic stripping-crimping machine, type **ZFU-CD**, is suitable to be used in workshops (where an electrical or pneumatic power supply is available) and for heavy workloads. It enables to produce large amounts of crimped connections in less time because of the possibility of simultaneously carrying out stripping and crimping operations. The contact and tool replacement operations, which are minimized because of the pre-set programs that can be stored and customized by the user, require the production to be programmed to reduce downtime. When a sequential processing is required despite the economic advantages offered by the above-described solution, it is preferable to use pneumatic bench pliers without the above-described positioner or one of the manual pliers.

In any case, the quality of the results from the crimping tools, combined with the ILME crimp contacts, is identical and at the highest market levels, exceeding the requirements of the standard EN 60352-2.

Although the crimping appliances and tools suggested here include a set of control automatisms and mechanisms, which prevent the chief misunderstandings and errors, the operator is advised to always take care not to work in inappropriate conditions.

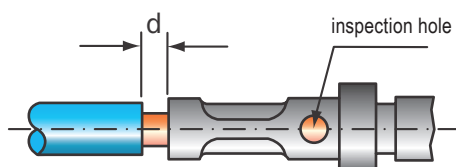
THE CRIMPING OPERATION

The practical guide in standard EN 60352-2 supplies further general information regarding crimp contacts for multipole connectors.

1. Insertion of the conductor in the crimp contacts

The conductor must be correctly positioned in the pin to be crimped. The crimping indentations must be correctly positioned on the foot to be crimped. There must be sufficient space, in conformity with the manufacturer's instructions, between the end of the insulating material of the conductor and the pin to be crimped ("d"). As a general rule, the stripping length is equal to the pin insertion depth + 1 mm (for sections up to 1 mm²) and + 2 mm (for sections from 1 to 10 mm²)*. When using closed crimp pins with an inspection hole, the crimp conductor must be visible through the inspection holes.

* Keeping the conductor strands visible above the contact collar enables you to check correct, i.e. make sure no strands have been cut. This also ensures a certain flexibility for the connection, by not transmitting to the contact any flexure stresses caused by installation. However, in practice, some operators give priority to insulation, by reducing to zero the gap between cable insulation and the contact collar.



2. Insertion of crimped contacts in the connector insert

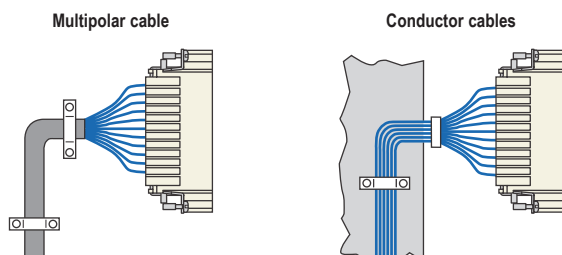
It is recommended that the crimped contacts be perfectly straight and inserted within the contact slots in a single operation and without excessive force until a clicking sound is heard. The correct retention of the contact should be verified with a light pulling of the wire. Non alignment of the crimped contacts must be avoided because this could cause possible loosening of the retention springs and consequently jeopardise the retention of the contact in the insert. For small section conductors ($\leq 0,35$ mm²) or for specific application, the use of the insertion tool specified by the manufacturer is recommended.

3. Removal of inserted contacts

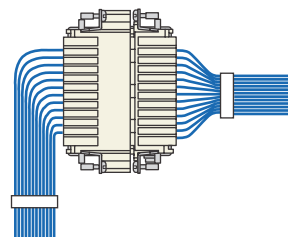
In the case of incorrect insertion or wiring substitution, inserted contacts may only be removed using the removal tools specified by the manufacturer.

4. Mounting and flexure of multi-wired bundles or multipolar cables with crimp contacts

Bundles of conductors or multipolar cables with crimp contacts for multipole connectors must not cause stress to the inserted contacts with their weight as this would cause the contacts to bend over to the coupling area of the connectors and consequently damage them. The connectors must therefore be provided with cable clamps or the conductor bundles or multipolar cables must be mounted as described in the figures below.



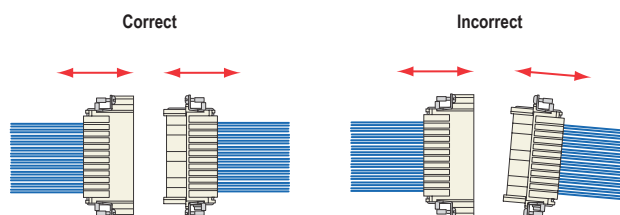
If the conductor bundles or the multipolar cables have to be immediately folded over on the back of the connector insert, it is recommended not to use any mechanical force in the axial direction with respect to the coupled contacts. The figure shows a correct bending and clamping of the multiwire bundles using the crimp contacts.



5. Coupling and uncoupling of multipolar connectors with crimp contacts

In order to prevent stress on the crimp contacts, the connectors must be coupled and uncoupled in the axial direction with respect to the contacts, without touching the conductor bundles or cables.


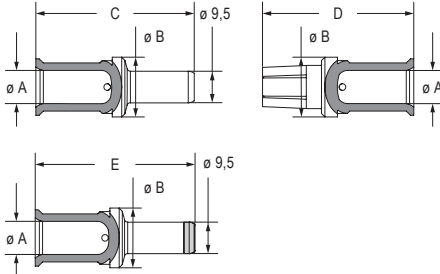

Standard DIN 43652 (incorporated into specification EN 175301-801) that applies to the ILME inserts of the CD series (this recommendation is also valid for the CDD series) prescribes a maximum deflection from the axis of $\pm 5^\circ$ on the greater side and $\pm 2^\circ$ on the smaller side.



To keep the play within this limit, especially during the uncoupling phase, guide pins CRM and CRF may be used.

Contact resistance	≤ 0,2 mΩ
Mechanical life (cycles)	≥ 500

(pending: cURus)

Item	Description	Part No.	Part No.	Dimension																																																								
	300 A crimp contacts	Male	Female																																																									
	section (mm ²)	section (AWG)																																																										
	16	6	C30MA 16		C30FA 16																																																							
	25	4	C30MA 25		C30FA 25																																																							
	35	2	C30MA 35		C30FA 35																																																							
	50	1	C30MA 50		C30FA 50																																																							
	70	2/0	C30MA 70		C30FA 70																																																							
	95	3/0	C30MA 95		C30FA 95																																																							
	120	4/0	C30MA 120		C30FA 120																																																							
		300 A finger-proof crimp contacts																																																										
		section (mm ²)	section (AWG)																																																									
		16	6		C30MA 16 P																																																							
		25	4		C30MA 25 P																																																							
35		2	C30MA 35 P																																																									
50		1	C30MA 50 P																																																									
70		2/0	C30MA 70 P																																																									
95	3/0	C30MA 95 P																																																										
120	4/0	C30MA 120 P																																																										
<p>Wiring information, C30 contacts</p> <table border="1"> <thead> <tr> <th>conductor section (mm²)</th> <th>conductor slot ø A (mm)</th> <th>ø B (mm)</th> <th>C (mm)</th> <th>D (mm)</th> <th>E (mm)</th> <th>conductor stripping length (mm)</th> </tr> </thead> <tbody> <tr> <td>16</td> <td>5,5</td> <td>18</td> <td>41,2</td> <td>39,1</td> <td>42,7</td> <td>19</td> </tr> <tr> <td>25</td> <td>7</td> <td>18</td> <td>41,2</td> <td>39,1</td> <td>42,7</td> <td>19</td> </tr> <tr> <td>35</td> <td>8,2</td> <td>18</td> <td>42,2</td> <td>40,1</td> <td>43,7</td> <td>20</td> </tr> <tr> <td>50</td> <td>10</td> <td>18</td> <td>47,7</td> <td>45,6</td> <td>49,2</td> <td>22,5</td> </tr> <tr> <td>70</td> <td>11,5</td> <td>18</td> <td>47,7</td> <td>45,6</td> <td>49,2</td> <td>22,5</td> </tr> <tr> <td>95</td> <td>13,5</td> <td>21</td> <td>47,7</td> <td>45,6</td> <td>49,2</td> <td>22,5</td> </tr> <tr> <td>120</td> <td>15,5</td> <td>21</td> <td>47,7</td> <td>45,6</td> <td>49,2</td> <td>22,5</td> </tr> </tbody> </table>					conductor section (mm ²)	conductor slot ø A (mm)	ø B (mm)	C (mm)	D (mm)	E (mm)	conductor stripping length (mm)	16	5,5	18	41,2	39,1	42,7	19	25	7	18	41,2	39,1	42,7	19	35	8,2	18	42,2	40,1	43,7	20	50	10	18	47,7	45,6	49,2	22,5	70	11,5	18	47,7	45,6	49,2	22,5	95	13,5	21	47,7	45,6	49,2	22,5	120	15,5	21	47,7	45,6	49,2	22,5
conductor section (mm ²)	conductor slot ø A (mm)	ø B (mm)	C (mm)	D (mm)	E (mm)	conductor stripping length (mm)																																																						
16	5,5	18	41,2	39,1	42,7	19																																																						
25	7	18	41,2	39,1	42,7	19																																																						
35	8,2	18	42,2	40,1	43,7	20																																																						
50	10	18	47,7	45,6	49,2	22,5																																																						
70	11,5	18	47,7	45,6	49,2	22,5																																																						
95	13,5	21	47,7	45,6	49,2	22,5																																																						
120	15,5	21	47,7	45,6	49,2	22,5																																																						

It is recommended to use the crimping tools homologated by ILME (please see page F.23)

Materials	
Contacts	copper alloy, silver ● plated

Inserts	Pages
MIXO modules 300 A	C.12-13

Contact resistance	$\leq 0,2 \text{ m}\Omega$
Mechanical life (cycles)	≥ 500



ECBT2.E115072 | ECBT8.E115072

Item	Description	Part No.	Part No.	Dimension	
	200 A crimp contacts	Male	Female		
	section (mm ²)	section (AWG)			
	16	6	CYMA 16		CYFA 16
	25	4	CYMA 25		CYFA 25
	35	2	CYMA 35		CYFA 35
	50	1	CYMA 50		CYFA 50
70	2/0	CYMA 70	CYFA 70		

silver

Wiring information, CY contacts

conductor section $\varnothing A$ (mm ²)	conductor slot (mm)	stripping length (mm)
16	6,1	15
25	7,0	15
35	8,2	15
50	9,8	15
70	11,8	15

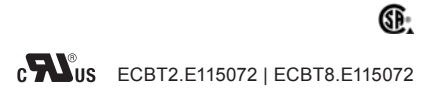
It is recommended to use the crimping tools homologated by ILME (please see page F.23)

Materials

Contacts	copper alloy, silver ● plated
----------	-------------------------------

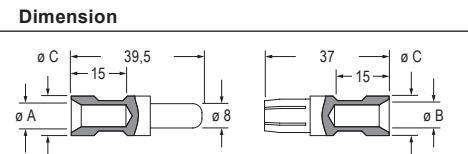
Inserts	Pages
MIXO modules	200 A C.16-17

Contact resistance	$\leq 0,3 \text{ m}\Omega$
Mechanical life (cycles)	≥ 500



Item	Description	Part No.	Part No.
	100 A crimp contacts	Male	Female
	section (mm ²)		
	section (AWG)		
	8-10	CGMA 10	CGFA 10
	16	CGMA 16	CGFA 16
25	CGMA 25	CGFA 25	
35	CGMA 35	CGFA 35	

silver


Wiring information, CG contacts

conductor section (mm ²)	conductor slot ø A (mm)	conductor slot ø B (mm)	conductor slot ø C (mm)	stripping length (mm)
8-10	4,3	4,3	13	15
16	5,5	5,5	13	15
25	7,0	7,0	13	15
35	7,9	8,2	12,5	15

It is recommended to use the crimping tools homologated by ILME (please see page F.23)

Materials

Contacts	copper alloy, silver ● plated
----------	-------------------------------

Inserts		Pages
CX 8/0	100 A	B.156
CX 6/6	100 A/16 A	B.157
MIXO modules	100 A	C.20-21,26

CX7 – RX7 HNM (High Number of Matings)

70 A crimp contacts

Contact resistance	≤ 0,5 mΩ
Mechanical life (cycles)	≥ 500
- CX7 series	≥ 10 000
- RX7 HNM series	≥ 10 000

(except of RX7 HNM contacts)

ECBT2.E115072 | ECBT8.E115072

Item	Description	Part No.	Part No.	Dimension	
	70 A crimp contacts	Male	Female		
	section (mm ²)	section (AWG)			
	6	10	silver CX7MA 6.0		CX7FA 6.0
	10	8-7	CX7MA 10		CX7FA 10
	16	6-5	CX7MA 16		CX7FA 16
	16 (XF)	6-5	CX7MA 16 XF		CX7FA 16 XF
	25	4-3	CX7MA 25		CX7FA 25
	70 A finger-proof crimp contacts				
	section (mm ²)	section (AWG)			
	6	10	silver CX7MA 6.0 P		
	10	8-7	CX7MA 10 P		
	16	6-5	CX7MA 16 P		
	16 (XF)	6-5	CX7MA 16 XFP		
25	4-3	CX7MA 25 P			

Wiring information, CX7 and CX7 P contacts

conductor section (mm ²)	conductor slot ø A (mm)	length B (mm)	length C (mm)	length D (mm)
6	3,5	36,0	33,0	36,6
10	4,3	35,2	32,2	35,8
16	5,5	35,2	32,2	35,8
16 (XF)	6,1	35,2	32,2	35,8
25	7,0	35,2	32,2	35,8

It is recommended to use the crimping tools homologated by ILME (please see page F.23)

Item	Description	Part No.	Part No.	Dimension	
	70 A HNM crimp contacts	Male	Female		
	section (mm ²)	section (AWG)			
	6	10	gold RX7M2D 6.0		RX7F2D 6.0
	10	8-7	RX7M2D 10		RX7F2D 10
	16	6-5	RX7M2D 16		RX7F2D 16
	16 (XF)	6-5	RX7M2D 16 XF		RX7F2D 16 XF
	25	4-3	RX7M2D 25		RX7F2D 25
	70 A HNM finger-proof crimp contacts				
	section (mm ²)	section (AWG)			
	6	10	gold RX7M2D 6.0 P		
	10	8-7	RX7M2D 10 P		
	16	6-5	RX7M2D 16 P		
	16 (XF)	6-5	RX7M2D 16XFP		
25	4-3	RX7M2D 25 P			

Wiring information, RX7 and RX7 P contacts

conductor section (mm ²)	conductor slot ø A (mm)	length B (mm)	length C (mm)	length D (mm)
6	3,5	36,0	33,0	36,6
10	4,3	35,2	32,2	35,8
16	5,5	35,2	32,2	35,8
16 (XF)	6,1	35,2	32,2	35,8
25	7,0	35,2	32,2	35,8

It is recommended to use the crimping tools homologated by ILME (please see page F.23)

Materials

Contacts	
- CX7 series	copper alloy, silver ● plated
- RX7 HNM series	copper alloy, gold ● plated (HNM version)



Watch our clip

Inserts	Pages	
CXC 4/2	80 A/16 A	B.160
CXC 4/8	80 A/16 A	B.162
MIXO modules	70 A	C.22

HNM Inserts	Pages	
RXC 4/2	80 A/16 A	H.30
RXC 4/8	80 A/16 A	H.31
HNM MIXO modules	70 A	H.38

CX – RX HNM (High Number of Matings)

40 A crimp contacts

Contact resistance	≤ 0,3 mΩ
Mechanical life (cycles)	
- CX series	≥ 500
- RX HNM series	≥ 10 000

(except of RX HNM contacts)

ECBT2.E115072 | ECBT8.E115072

Item	Description	Part No.	Part No.	Dimension	
	40 A crimp contacts	Male	Female		
	section (mm ²)	section (AWG)			
	1,5	16	CXMA 1.5		CXFA 1.5
	2,5	14	CXMA 2.5		CXFA 2.5
	4	12	CXMA 4.0		CXFA 4.0
	6	10	CXMA 6.0		CXFA 6.0
	10	8	CXMA 10	CXFA 10	

silver

Wiring information, CX contacts

conductor section (mm ²)	conductor slot ø A (mm)	stripping length B (mm)
1,5	1,8	9
2,5	2,2	9
4	2,85	9,6
6	3,5	9,6
10	4,3	15

It is recommended to use the crimping tools homologated by ILME (please see page F.23)

Item	Description	Part No.	Part No.	Dimension	
	40 A HNM crimp contacts	Male	Female		
	section (mm ²)	section (AWG)			
	1,5	16	RXM2D 1.5		RXF2D 1.5
	2,5	14	RXM2D 2.5		RXF2D 2.5
	4	12	RXM2D 4.0		RXF2D 4.0
	6	10	RXM2D 6.0		RXF2D 6.0
	10	8	RXM2D 10	RXF2D 10	

gold

Wiring information, RX contacts

conductor section (mm ²)	conductor slot ø A (mm)	stripping length B (mm)
1,5	1,8	9
2,5	2,2	9
4	2,85	9,6
6	3,5	9,6
10	4,3	15

It is recommended to use the crimping tools homologated by ILME (please see page F.23)

Materials

Contacts	
- CX series	copper alloy, silver ● plated
- RX HNM series	copper alloy, gold ● plated (HNM version)

Inserts		Pages
CQ4 02 H / CQ4 02 / CQ4 03	40 A	A.4-6
CQ4 03/2	40 A/10 A	A.7
CQ 04/2E / CQ 04/2 / CQ 04/2B	40 A/10 A	B.6-8
CX 12/2	40 A/10 A	B.163
CX 6/12	40 A/10 A	B.164
CX 9/42	40 A/10 A	B.168
CX 6/36	40 A/10 A	B.169
MIXO modules	40 A	C.31,33,35-37,52

HNM Inserts		Pages
CQ4 03	40 A	H.6
RX 12/2	40 A/10 A	H.32
HNM MIXO modules	40 A	H.39-43

CC – RC HNM (High Number of Matings)

16 A crimp contacts

Contact resistance	≤ 1 mΩ
Mechanical life (cycles)	≥ 500
- CC series	≥ 10 000
- RC series	≥ 10 000

(except of RC HNM contacts)

ECBT2.E115072 | ECBT8.E115072

Item	Description	Part No.	Part No.	Dimension
	16 A advanced opening contacts section (mm ²) section (AWG) 0,5 20 0,75 18 1 18 1,5 16 2,5 14	Male CC 0.5 AN CC 0.7 AN CC 1.0 AN CC 1.5 AN CC 2.5 AN	Female	
	16 A crimp contacts section (mm ²) section (AWG) 0,14-0,37 26-22 0,5 20 0,75 18 1 18 1,5 16 2,5 14 3 12 4 12	CCMA 0.3 CCMA 0.5 CCMA 0.7 CCMA 1.0 CCMA 1.5 CCMA 2.5 CCMA 3.0 CCMA 4.0	CCFA 0.3 CCFA 0.5 CCFA 0.7 CCFA 1.0 CCFA 1.5 CCFA 2.5 CCFA 3.0 CCFA 4.0	
	16 A HNM crimp contacts section (mm ²) section (AWG) 0,14-0,37 26-22 0,5 20 0,75 18 1 18 1,5 16 2,5 14 3 12 4 12	CCMD 0.3 CCMD 0.5 CCMD 0.7 CCMD 1.0 CCMD 1.5 CCMD 2.5 CCMD 3.0 CCMD 4.0	CCFD 0.3 CCFD 0.5 CCFD 0.7 CCFD 1.0 CCFD 1.5 CCFD 2.5 CCFD 3.0 CCFD 4.0	
	16 A HNM crimp contacts section (mm ²) section (AWG) 0,14-0,37 26-22 0,5 20 0,75 18 1 18 1,5 16 2,5 14 3 12 4 12	RCM2D 0.3 RCM2D 0.5 RCM2D 0.7 RCM2D 1.0 RCM2D 1.5 RCM2D 2.5 RCM2D 3.0 RCM2D 4.0	RCF2D 0.3 RCF2D 0.5 RCF2D 0.7 RCF2D 1.0 RCF2D 1.5 RCF2D 2.5 RCF2D 3.0 RCF2D 4.0	

Wiring information, CC contacts

conductor section (mm ²)	conductor slot ø A (mm)	stripping length (mm)
0,14-0,37	0,9	7,5
0,5	1,1	7,5
0,75	1,3	7,5
1,0	1,45	7,5
1,5	1,8	7,5
2,5	2,2	7,5
3,0	2,55	7,5
4,0	2,85	7,5

It is recommended to use the crimping tools homologated by ILME (please see page F.23)

Wiring information, RC contacts

conductor section (mm ²)	conductor slot ø A (mm)	stripping length (mm)
0,14-0,37	0,9	7,5
0,5	1,1	7,5
0,75	1,3	7,5
1,0	1,45	7,5
1,5	1,8	7,5
2,5	2,2	7,5
3,0	2,55	7,5
4,0	2,85	7,5

It is recommended to use the crimping tools homologated by ILME (please see page F.23)

Materials

Contacts	
- CC series	copper alloy, silver ● and gold ● plated
- RC series	copper alloy, gold ● plated (HNM version)

Inserts	Pages
CQ 05	16 A A.8
CQ 08E / CQ 08	16 A B.9,11
CDC	16 A B.19-21
CCE	16 A B.44-49
CQE	16 A B.72-77
CQEE	16 A B.78-79
CMCE	16 A B.144-148
CX 6/6*	100 A/16 A B.157
CXC 4/2*	80 A/16 A B.160
CXC 4/8*	80 A/16 A B.162
CX 8/24	16 A/10 A B.170-171
MIXO modules	16 A C.39-41,43,53-54

HNM Inserts	Pages
RQ 05	16 A H.7
RCE	16 A H.10-13
RQEE	16 A H.18-19
RXC 4/2*	80 A/16 A H.30
RXC 4/8*	80 A/16 A H.31
HNM MIXO modules	16 A H.44-47

* The insert polarities that require the contacts shown on this page as auxiliaries are highlighted in **bold**.

Contact resistance	≤ 1 mΩ
Mechanical life (cycles)	≥ 200

ECBT2.E115072 | ECBT8.E115072

Item	Description	Part No.	Part No.	Dimension	
	16 A crimp contacts	Male	Female		
	section (mm ²)	section (AWG)			
	0,14-0,37	26-22	CCMS 0.3		CCFS 0.3
	0,5	20	CCMS 0.5		CCFS 0.5
	0,75	18	CCMS 0.7		CCFS 0.7
	1	18	CCMS 1.0		CCFS 1.0
	1,5	16	CCMS 1.5		CCFS 1.5
	2,5	14	CCMS 2.5		CCFS 2.5
	3	12	CCMS 3.0		CCFS 3.0
	4	12	CCMS 4.0		CCFS 4.0

Wiring information, CC S contacts

conductor section (mm ²)	conductor slot ø A (mm)	stripping length (mm)
0,14-0,37	0,9	7,5
0,5	1,1	7,5
0,75	1,3	7,5
1,0	1,45	7,5
1,5	1,8	7,5
2,5	2,2	7,5
3,0	2,55	7,5
4,0	2,85	7,5

It is recommended to use the crimping tools homologated by ILME (please see page F.23)

Materials

Contacts	copper alloy, tin ● plated
----------	----------------------------

Inserts		Pages
CQ 05	16 A	A.8
CQ 08E / CQ 08	16 A	B.9,11
CDC	16 A	B.19-21
CCE	16 A	B.44-49
CQE	16 A	B.72-77
CQEE	16 A	B.78-79
CMCE	16 A	B.144-148
CX 6/6*	100 A/ 16 A	B.157
CXC 4/2*	80 A/ 16 A	B.160
CXC 4/8*	80 A/ 16 A	B.162
CX 8/24	16 A/10 A	B.170-171
MIXO modules	16 A	C.39-41,43,53-54

* The insert polarities that require the contacts shown on this page as auxiliaries are highlighted in **bold**.

CC

16 A high thickness and basic crimp contacts

Contact resistance	≤ 1 mΩ
Corrosion resistance according to:	EN 60068
Mechanical life (cycles)	≥ 500

ECBT2.E115072 | ECBT8.E115072

Item	Description	Part No.	Part No.	Dimension	
	high thickness 16 A crimp contacts	Male	Female		
	section (mm ²)	section (AWG)			
	0,14-0,37	26-22	CCM2D 0.3		CCF2D 0.3
	0,5	20	CCM2D 0.5		CCF2D 0.5
	0,75	18	CCM2D 0.7		CCF2D 0.7
	1	18	CCM2D 1.0		CCF2D 1.0
	1,5	16	CCM2D 1.5		CCF2D 1.5
	2,5	14	CCM2D 2.5		CCF2D 2.5
	3	12	CCM2D 3.0		CCF2D 3.0
	4	12	CCM2D 4.0		CCF2D 4.0

Wiring information, CC 2D contacts

conductor section (mm ²)	conductor slot ø A (mm)	stripping length (mm)
0,14-0,37	0,9	7,5
0,5	1,1	7,5
0,75	1,3	7,5
1,0	1,45	7,5
1,5	1,8	7,5
2,5	2,2	7,5
3,0	2,55	7,5
4,0	2,85	7,5

It is recommended to use the crimping tools homologated by ILME (please see page F.23)

Item	Description	Part No.	Part No.	Dimension	
	basic 16 A crimp contacts	Male	Female		
	section (mm ²)	section (AWG)			
	0,14-0,37	26-22	CCMJJD 0.3		CCFJD 0.3
	0,5	20	CCMJJD 0.5		CCFJD 0.5
	0,75	18	CCMJJD 0.7		CCFJD 0.7
	1	18	CCMJJD 1.0		CCFJD 1.0
	1,5	16	CCMJJD 1.5		CCFJD 1.5
	2,5	14	CCMJJD 2.5		CCFJD 2.5
	3	12	CCMJJD 3.0		CCFJD 3.0
	4	12	CCMJJD 4.0		CCFJD 4.0

Wiring information, CC JD contacts

conductor section (mm ²)	conductor slot ø A (mm)	stripping length (mm)
0,14-0,37	0,9	7,5
0,5	1,1	7,5
0,75	1,3	7,5
1,0	1,45	7,5
1,5	1,8	7,5
2,5	2,2	7,5
3,0	2,55	7,5
4,0	2,85	7,5

It is recommended to use the crimping tools homologated by ILME (please see page F.23)

Materials

Contacts	copper alloy, gold plated
----------	----------------------------

Inserts	Pages
CQ 05	16 A A.8
CQ 08E / CQ 08	16 A B.9,11
CDC	16 A B.19-21
CCE	16 A B.44-49
CQE	16 A B.72-77
CQEE	16 A B.78-79
CMCE	16 A B.144-148
CX 6/6*	100 A/ 16 A B.157
CXC 4/2*	80 A/ 16 A B.160
CXC 4/8*	80 A/ 16 A B.162
CX 8/24	16 A/10 A B.170-171
MIXO modules	16 A C.39-41,43,53-54

* The insert polarities that require the contacts shown on this page as auxiliaries are highlighted in **bold**.


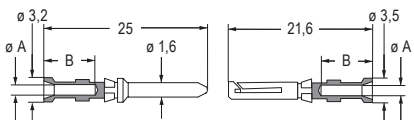

CD – RD HNM (High Number of Matings)

10 A crimp contacts

Contact resistance	≤ 3 mΩ
Mechanical life (cycles)	
- CD series	≥ 500
- RD HNM series	≥ 10 000

 (except of RD HNM contacts)


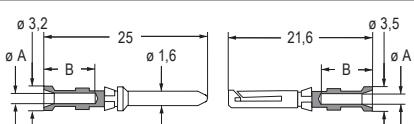
 ECBT2.E115072 | ECBT8.E115072

Item	Description	Part No.	Part No.	Dimension	
	10 A crimp contacts	Male	Female		
	section (mm ²)	section (AWG)			
	0,14-0,37	26-22	silver		
	0,5	20	CDMA 0.3		CDFA 0.3
	0,75	18	CDMA 0.5		CDFA 0.5
	1	18	CDMA 0.7		CDFA 0.7
	1,5	16	CDMA 1.0		CDFA 1.0
	2,5	14	CDMA 1.5		CDFA 1.5
			CDMA 2.5		CDFA 2.5
		0,14-0,37	26-22		gold
0,5		20	CDMD 0.3	CDFD 0.3	
0,75		18	CDMD 0.5	CDFD 0.5	
1		18	CDMD 0.7	CDFD 0.7	
1,5		16	CDMD 1.0	CDFD 1.0	
2,5		14	CDMD 1.5	CDFD 1.5	
			CDMD 2.5	CDFD 2.5	

Wiring information, CD contacts

conductor section (mm ²)	conductor slot ø A (mm)	stripping length B (mm)
0,14-0,37	0,9	8
0,5	1,1	8
0,75	1,3	8
1,0	1,45	8
1,5	1,8	8
2,5	2,2	6

It is recommended to use the crimping tools homologated by ILME (please see page F.23)

Item	Description	Part No.	Part No.	Dimension	
	10 A HNM crimp contacts	Male	Female		
	section (mm ²)	section (AWG)			
	0,14-0,37	26-22	gold		
	0,5	20	RDM2D 0.3		RDF2D 0.3
	0,75	18	RDM2D 0.5		RDF2D 0.5
	1	18	RDM2D 0.7		RDF2D 0.7
	1,5	16	RDM2D 1.0		RDF2D 1.0
	2,5	14	RDM2D 1.5		RDF2D 1.5
			RDM2D 2.5		RDF2D 2.5

Wiring information, RD contacts

conductor section (mm ²)	conductor slot ø A (mm)	stripping length B (mm)
0,14-0,37	0,9	8
0,5	1,1	8
0,75	1,3	8
1,0	1,45	8
1,5	1,8	8
2,5	2,2	6

It is recommended to use the crimping tools homologated by ILME (please see page F.23)

Materials

Contacts	
- CD series	copper alloy, silver ● and gold ● plated
- RD HNM series	copper alloy, gold ● plated (HNM version)

Inserts	Pages
CQ4 03/2*	40 A/10 A A.7
CQ 07 / CQ 12	10 A A.10-11
CD 07 / CD 08	10 A A.22, 24
CX 1/2 BD*	10 A A.37
CQ 04/2E*	40 A/10 A B.6
CQ 04/2* / CQ 04/2B*	40 A/10 A B.7-8
CQ 17	10 A B.12
CD	10 A B.30-32
CDD	10 A B.33-34
CD	10 A B.90-93
CDD	10 A B.94-99
CX 12/2*	40 A/10 A B.163
CX 6/12*	40 A/10 A B.164
CX 9/42*	40 A/10 A B.168
CX 6/36*	40 A/10 A B.169
CX 8/24*	16 A/10 A B.170-171
MIXO modules	10 A C.46,48-49,58,64,74-75

HNM Inserts	Pages
CD 08	10 A H.9
RD	10 A H.20-21
RDD	10 A H.22-25
RX 12/2*	40 A/10 A H.32
HNM MIXO modules	10 A H.48-50,53

* The insert polarities that require the contacts shown on this page as auxiliaries are highlighted in **bold**.

CD

10 A tin plated crimp contacts

Contact resistance	≤ 3 mΩ
Mechanical life (cycles)	≥ 200

ECBT2.E115072 | ECBT8.E115072

Item	Description	Part No.		Dimension
		Male	Female	
	10 A crimp contacts			
	section (mm ²)	section (AWG)		
	0,14-0,37	26-22		
	0,5	20		
	0,75	18		
	1	18		
	1,5	16		
	2,5	14		
		CDMS 0.3 CDMS 0.5 CDMS 0.7 CDMS 1.0 CDMS 1.5 CDMS 2.5	CDFS 0.3 CDFS 0.5 CDFS 0.7 CDFS 1.0 CDFS 1.5 CDFS 2.5	

Wiring information, CD S contacts

conductor section (mm ²)	conductor slot ϕ A (mm)	stripping length B (mm)
0,14-0,37	0,9	8
0,5	1,1	8
0,75	1,3	8
1,0	1,45	8
1,5	1,8	8
2,5	2,2	6

It is recommended to use the crimping tools homologated by ILME (please see page F.23)

Materials

Contacts	copper alloy, tin ● plated
----------	----------------------------

Inserts		Pages
CQ4 03/2*	40 A/ 10 A	A.7
CQ 07 / CQ 12	10 A	A.10-11
CD 07 / CD 08	10 A	A.22, 24
CX 1/2 BD*	10 A	A.37
CQ 04/2E*	40 A/ 10 A	B.6
CQ 04/2* / CQ 04/2B*	40 A/ 10 A	B.7-8
CQ 17	10 A	B.12
CD	10 A	B.30-32
CDD	10 A	B.33-34
CD	10 A	B.90-93
CDD	10 A	B.94-99
CX 12/2*	40 A/ 10 A	B.163
CX 6/12*	40 A/ 10 A	B.164
CX 9/42*	40 A/ 10 A	B.168
CX 6/36*	40 A/ 10 A	B.169
CX 8/24*	16 A/ 10 A	B.170-171
MIXO modules	10 A	C.46,48-49,58,64,74-75

* The insert polarities that require the contacts shown on this page as auxiliaries are highlighted in **bold**.

Contact resistance	≤ 3 mΩ
Corrosion resistance according to:	EN 60068
Mechanical life (cycles)	≥ 500

ECBT2.E115072 | ECBT8.E115072

Item	Description	Part No.	Part No.	Dimension		
	high thickness 10 A crimp contacts	Male	Female			
	section (mm ²)	section (AWG)				
	0,14-0,37	26-22			CDM2D 0.3	CDF2D 0.3
	0,5	20			CDM2D 0.5	CDF2D 0.5
	0,75	18			CDM2D 0.7	CDF2D 0.7
	1	18			CDM2D 1.0	CDF2D 1.0
	1,5	16			CDM2D 1.5	CDF2D 1.5
2,5	14	CDM2D 2.5		CDF2D 2.5		
Wiring information, CD 2D contacts						
conductor section (mm ²)	conductor slot (mm)	slot ø A (mm)	stripping length B (mm)			
0,14-0,37	0,9	8				
0,5	1,1	8				
0,75	1,3	8				
1,0	1,45	8				
1,5	1,8	8				
2,5	2,2	6				

It is recommended to use the crimping tools homologated by ILME (please see page F.23)

Item	Description	Part No.	Part No.	Dimension		
	basic 10 A crimp contacts	Male	Female			
	section (mm ²)	section (AWG)				
	0,14-0,37	26-22			CDMJJD 0.3	CDFJD 0.3
	0,5	20			CDMJJD 0.5	CDFJD 0.5
	0,75	18			CDMJJD 0.7	CDFJD 0.7
	1	18			CDMJJD 1.0	CDFJD 1.0
	1,5	16			CDMJJD 1.5	CDFJD 1.5
2,5	14	CDMJJD 2.5		CDFJD 2.5		
Wiring information, CD JD contacts						
conductor section (mm ²)	conductor slot (mm)	slot ø A (mm)	stripping length B (mm)			
0,14-0,37	0,9	8				
0,5	1,1	8				
0,75	1,3	8				
1,0	1,45	8				
1,5	1,8	8				
2,5	2,2	6				

It is recommended to use the crimping tools homologated by ILME (please see page F.23)

Materials

Contacts	copper alloy, gold plated
----------	----------------------------

Inserts

Inserts		Pages
CQ4 03/2*	40 A/ 10 A	A.7
CQ 07 / CQ 12	10 A	A.10-11
CD 07 / CD 08	10 A	A.22, 24
CX 1/2 BD*	10 A	A.37
CQ 04/2E*	40 A/ 10 A	B.6
CQ 04/2* / CQ 04/2B*	40 A/ 10 A	B.7-8
CQ 17	10 A	B.12
CD	10 A	B.30-32
CDD	10 A	B.33-34
CD	10 A	B.90-93
CDD	10 A	B.94-99
CX 12/2*	40 A/ 10 A	B.163
CX 6/12*	40 A/ 10 A	B.164
CX 9/42*	40 A/ 10 A	B.168
CX 6/36*	40 A/ 10 A	B.169
CX 8/24*	16 A/ 10 A	B.170-171
MIXO modules	10 A	C.46,48-49,58,64,74-75

* The insert polarities that require the contacts shown on this page as auxiliaries are highlighted in **bold**.

CI – RI HNM (High Number of Matings)

5 A crimp contacts

Contact resistance	≤ 4 mΩ
Mechanical life (cycles)	≥ 500
- CI series	≥ 10 000
- RI HNM series	≥ 10 000

(except of RI HNM contacts and contacts size 0.7)

ECBT2.E115072 | ECBT8.E115072

Item	Description	Part No.	Part No.	Dimension	
	5 A crimp contacts	Male	Female		
	section (mm ²)	section (AWG)			
	0,08-0,21	28-24	CIMA 0.2		CIFA 0.2
	0,13-0,33	26-22	CIMA 0.3		CIFA 0.3
	0,33-0,52	22-20	CIMA 0.5		CIFA 0.5
	0,52-0,75	20-18	CIMA 0.7	CIFA 0.7	

Item	Description	Part No.	Part No.	Dimension	
	5 A crimp contacts	Male	Female		
	section (mm ²)	section (AWG)			
	0,08-0,21	28-24	CIMD 0.2		CIFD 0.2
	0,13-0,33	26-22	CIMD 0.3		CIFD 0.3
	0,33-0,52	22-20	CIMD 0.5		CIFD 0.5
	0,52-0,75	20-18	CIMD 0.7	CIFD 0.7	

Wiring information, CI contacts

conductor section (mm ²)	conductor slot ø A (mm)	stripping length (mm)
0,08-0,21	0,64	4
0,13-0,33	0,9	4
0,33-0,52	1,12	4
0,52-0,75	1,3	4

It is recommended to use the crimping tools homologated by ILME (please see page F.23)

Item	Description	Part No.	Part No.	Dimension	
	5 A HNM crimp contacts	Male	Female		
	section (mm ²)	section (AWG)			
	0,08-0,21	28-24	RIMD 0.2		RIFD 0.2
	0,13-0,33	26-22	RIMD 0.3		RIFD 0.3
	0,33-0,52	22-20	RIMD 0.5		RIFD 0.5
	0,52-0,75	20-18	RIMD 0.7	RIFD 0.7	

Wiring information, RI contacts

conductor section (mm ²)	conductor slot ø A (mm)	stripping length (mm)
0,08-0,21	0,64	4
0,13-0,33	0,9	4
0,33-0,52	1,12	4
0,52-0,75	1,3	4

It is recommended to use the crimping tools homologated by ILME (please see page F.23)

Item	Description	Part No.	Part No.	Dimension	
	high thickness 5 A crimp contacts	Male	Female		
	section (mm ²)	section (AWG)			
	0,08-0,21	28-24	CIM2D 0.2		CIF2D 0.2
	0,13-0,33	26-22	CIM2D 0.3		CIF2D 0.3
	0,33-0,52	22-20	CIM2D 0.5		CIF2D 0.5
	0,52-0,75	20-18	CIM2D 0.7	CIF2D 0.7	

Wiring information, CI contacts

conductor section (mm ²)	conductor slot ø A (mm)	stripping length (mm)
0,08-0,21	0,64	4
0,13-0,33	0,9	4
0,33-0,52	1,12	4
0,52-0,75	1,3	4

It is recommended to use the crimping tools homologated by ILME (please see page F.23)

Item	Description	Part No.	Part No.	Dimension	
	basic 5 A crimp contacts	Male	Female		
	section (mm ²)	section (AWG)			
	0,08-0,21	28-24	CIMJD 0.2		CIFJD 0.2
	0,13-0,33	26-22	CIMJD 0.3		CIFJD 0.3
	0,33-0,52	22-20	CIMJD 0.5		CIFJD 0.5
	0,52-0,75	20-18	CIMJD 0.7	CIFJD 0.7	

Materials


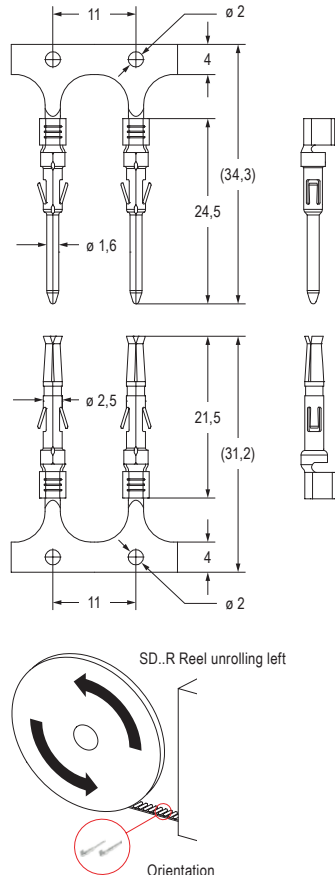
Contacts	
- CI series	copper alloy, silver ● and gold ● plated
- RI HNM series	copper alloy, gold ● plated (HNM version)

Inserts	Pages
CQ 21	6,5 A A.12
MIXO modules	5 A and 4 A C.50-51,59-60,65,79

HNM Inserts	Pages
CQ 21	6,5 A H.8
HNM MIXO modules	5 A and 4 A H.51-52,54-55

Contact resistance	≤ 10 mΩ
Mechanical life (cycles)	≥ 500

(pending: cURus)

Item	Description	Part No.	Part No.	Dimension
	10 A crimp contacts (loose parts) 1 packaging unit: 200 pcs. section (mm ²) section (AWG) 0,37-1 24-18 1,5-2,5 16-14	Male silver SDMA 1.0 SDMA 2.5	Female SDFA 1.0 SDFA 2.5	
	10 A crimp contacts (reel package) 1 packaging unit: 5.000 pcs. section (mm ²) section (AWG) 0,37-1 24-18 1,5-2,5 16-14	Male silver SDMA 1.0R SDMA 2.5R	Female SDFA 1.0R SDFA 2.5R	
	<u>Loose parts</u> recommended crimping tool: SIPZ W <u>Reel package</u> recommended crimping tool: suitable for stripping / crimping automated machines to be used with 5 000 pieces reels, see pages F.52 for 10 A crimp contacts.			

Materials	
Contacts	copper alloy, silver ● plated

Inserts		Pages
CQ4 03/2*	40 A/ 10 A	A.7
CQ 07 / CQ 12	10 A	A.10-11
CD 07 / CD 08	10 A	A.22, 24
CX 1/2 BD*	10 A	A.37
CQ 04/2E*	40 A/ 10 A	B.6
CQ 04/2* / CQ 04/2B*	40 A/ 10 A	B.7-8
CQ 17	10 A	B.12
CD	10 A	B.30-32
CDD	10 A	B.33-34
CD	10 A	B.90-93
CDD	10 A	B.94-99
CX 12/2*	40 A/ 10 A	B.163
CX 6/12*	40 A/ 10 A	B.164
CX 9/42*	40 A/ 10 A	B.168
CX 6/36*	40 A/ 10 A	B.169
CX 8/24*	16 A/ 10 A	B.170-171
MIXO modules	10 A	C.46,48-49,58,64,74-75


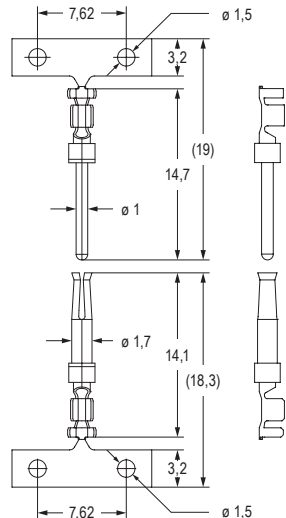
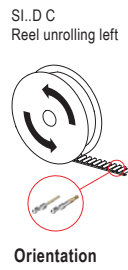
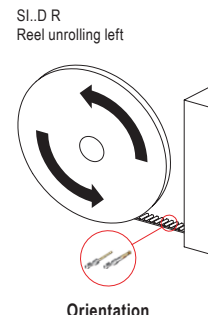
* The insert polarities that require the contacts shown on this page as auxiliaries are highlighted in **bold**.



5 A stamped crimp contacts

Contact resistance	≤ 10 mΩ
Mechanical life (cycles)	
- SI..1D	≥ 500
- SI..2D	≥ 250
- SI..3D	≥ 50

CALUS ECBT2.E115072 | ECBT8.E115072

Item	Description	Part No.	Part No.	Dimension	
	5 A crimp contacts (loose parts) 1 packaging unit: 200 pcs.	Male	Female		
	section (mm ²) section (AWG)				
	0,08-0,21 28-24	pl SIM1D 0.2	SIF1D 0.2		
	0,08-0,21 28-24	SIM2D 0.2	SIF2D 0.2		
	0,08-0,21 28-24	SIM3D 0.2	SIF3D 0.2		
	0,21-0,52 24-20	pl SIM1D 0.5	SIF1D 0.5		
	0,21-0,52 24-20	SIM2D 0.5	SIF2D 0.5		
	0,21-0,52 24-20	SIM3D 0.5	SIF3D 0.5		
	5 A crimp contacts (coil package) 1 packaging unit: 500 pcs.	section (mm ²) section (AWG)			
	0,08-0,21 28-24	pl SIM1D 0.2C	SIF1D 0.2C		
	0,08-0,21 28-24	SIM2D 0.2C	SIF2D 0.2C		
	0,08-0,21 28-24	SIM3D 0.2C	SIF3D 0.2C		
	0,21-0,52 24-20	pl SIM1D 0.5C	SIF1D 0.5C		
	0,21-0,52 24-20	SIM2D 0.5C	SIF2D 0.5C		
	0,21-0,52 24-20	SIM3D 0.5C	SIF3D 0.5C		
5 A crimp contacts (reel package) 1 packaging unit: 10.000 pcs.	section (mm ²) section (AWG)				
0,08-0,21 28-24	pl SIM1D 0.2R	SIF1D 0.2R			
0,08-0,21 28-24	SIM2D 0.2R	SIF2D 0.2R			
0,08-0,21 28-24	SIM3D 0.2R	SIF3D 0.2R			
0,21-0,52 24-20	gold SIM1D 0.5R	SIF1D 0.5R			
0,21-0,52 24-20	SIM2D 0.5R	SIF2D 0.5R			
0,21-0,52 24-20	SIM3D 0.5R	SIF3D 0.5R			
<p>SIM1D/SIF1D and SIM3D/SIF3D crimp contacts are available on request</p> <p>Loose parts recommended crimping tool: SIPZ W Coil package recommended crimping tool: SIPZC W Reel package recommended crimping tool: suitable for stripping / crimping automated machines to be used with 10 000 pieces reels, see pages F.53 for 5 A crimp contacts.</p>					
				 	


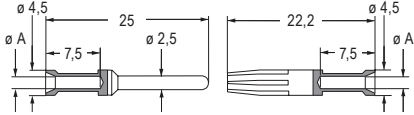
Materials	
Contacts	copper alloy, selective gold ● plated

Inserts		Pages
CQ 21	6,5 A	A.12
MIXO modules	5 A and 4 A	C.50-51,59-60,65,79

CC..C – CC..F

constantan and iron crimp contacts


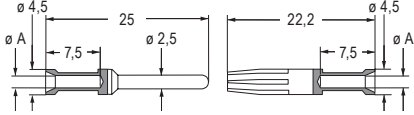
Contact resistance	≤ 1 Ω
Type J thermocouples compliant with:	EN 60584-1
Mechanical life (cycles)	≥ 500

Item	Description	Part No.	Part No.	Dimension
	constantan 16 A crimp contacts section (mm ²) section (AWG) 0,3 22 0,5 20	Male constantan CCMC 0.3 CCMC 0.5	Female CCFC 0.3 CCFC 0.5	

Wiring information, CC C contacts

conductor section (mm ²)	conductor slot ø A (mm)	stripping length (mm)
0,3	1,1	7,5
0,5	1,1	7,5

It is recommended to use the crimping tools homologated by ILME (please see page F.23)

	iron 16 A crimp contacts section (mm ²) section (AWG) 0,3 22 0,5 20	Male iron CCMF 0.3 CCMF 0.5	Female CCFF 0.3 CCFF 0.5	
--	--	---	---	--

Wiring information, CC F contacts

conductor section (mm ²)	conductor slot ø A (mm)	stripping length (mm)
0,14-0,37	1,1	7,5
0,5	1,1	7,5

It is recommended to use the crimping tools homologated by ILME (please see page F.23)

Materials

Contacts	
- CC...C	constantan ● (CuNi)
- CC...F	iron ● (Fe)

A mixed combination of iron, constantan and silver/gold plated can be fitted in the same insert

CRIMP CONTACTS

F


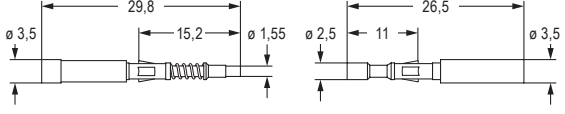
Inserts		Pages
CQ 05	16 A	A.8
CQ 08E / CQ 08	16 A	B.9,11
CDC	16 A	B.19-21
CCE	16 A	B.44-49
CQE	16 A	B.72-77
CQEE	16 A	B.78-79
CMCE	16 A	B.144-148
CX 6/6*	100 A/ 16 A	B.157
CXC 4/2*	80 A/ 16 A	B.160
CXC 4/8*	80 A/ 16 A	B.162
CX 8/24	16 A/10 A	B.170-171
MIXO modules	16 A	C.39-41,43,53-54

* The insert polarities that require the contacts shown on this page as auxiliaries are highlighted in **bold**.

CL

POF crimp contacts

Ambient temperature limit	-40 °C ... +85 °C
Mechanical life (cycles)	≥ 500

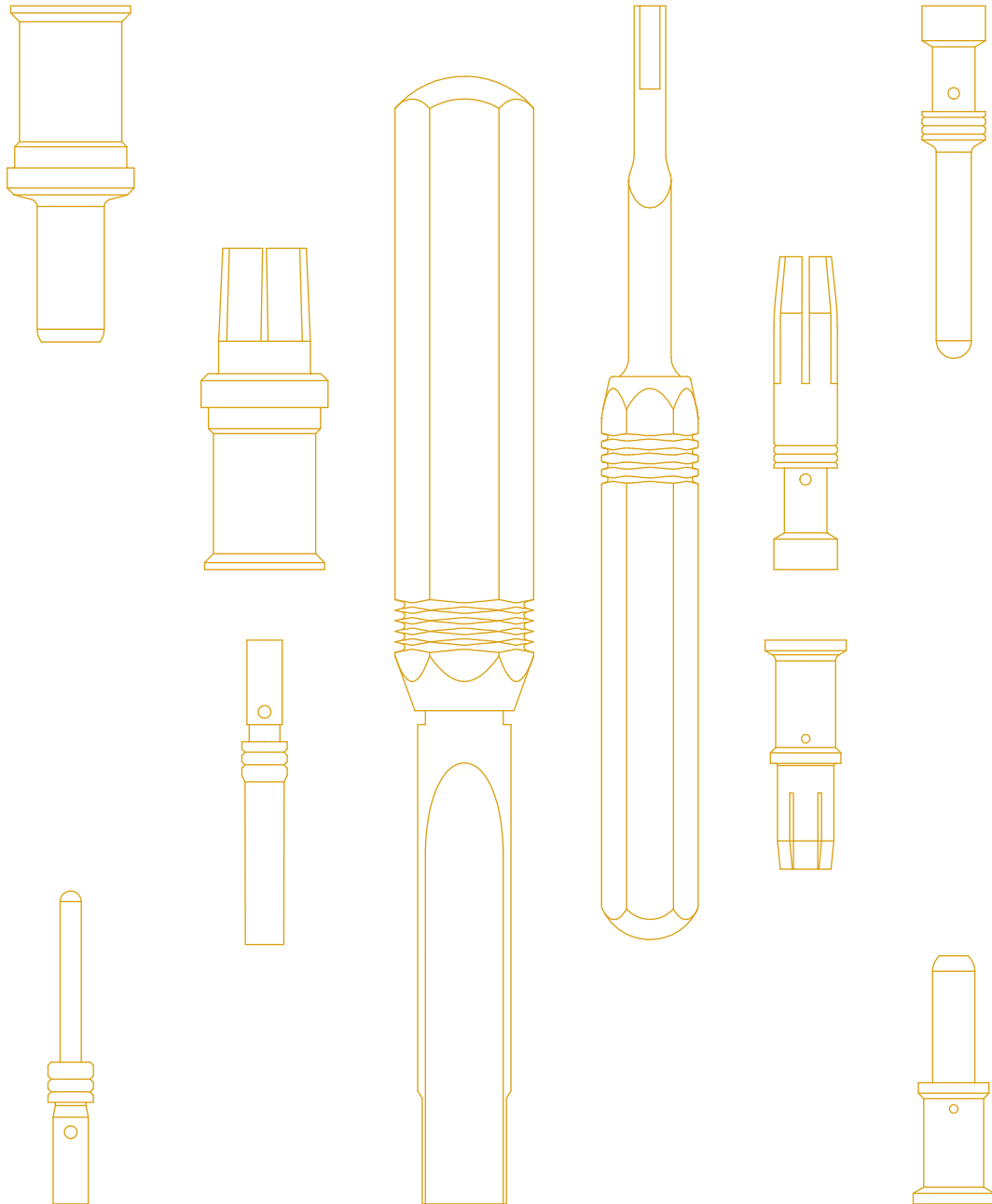
Item	Description	Part No.	Dimension
	<p>Male crimp contacts for POF Female crimp contacts for POF</p> <p>Max external diameter: 2,2 mm Polymer fibre diameter: min. 1 mm</p> <p>Conductor stripping length (male): 19 mm min. Conductor stripping length (female): 14 mm min.</p> <p>It is recommended to use the crimping tools homologated by ILME (please see page F.23)</p> <p>It is recommended to use coding pins CRM CX / CRF CX</p>	<p>CLM DD CLF DD</p>	



Tutorial

Inserts		Pages
CQ 07 / CQ 12	10 A	A.10-11
CQ 17	10 A	B.12
CDD	10 A	B.33-34
CDD	10 A	B.94-99
CX 12/2*	40 A/ 10 A	B.163
CX 6/36*	40 A/ 10 A	B.169
CX 8/24*	16 A/ 10 A	B.170-171
MIXO modules	10 A	C.46,48

* The insert polarities that require the contacts shown on this page as auxiliaries are highlighted in **bold**.



GENERAL CATALOGUE

Tools

See Crimp contacts from page F.1

Contents




Tools			
Crimp			
	Hex profile		
	- C13PZ C	300 A	F.24
	- C13PZE C	300 A	F.25
	- CPPZ C	200 A / 100 A / 70 A	F.26-27
	- CPPZE C / CPPZEH C	200 A / 100 A / 70 A	F.28-29
<hr/>			
	MIL profile		
	- CXPZ D	40 A	F.30-31
	- CXPZP D	40 A	F.32-33
	- CCPZ MIL	16 A / 10 A	F.34-35
	- CCPZP / CCPZA	16 A / 10 A	F.36-39
	- CCPZ RN	40 A / 16 A / 10 A	F.40-41
	- CCPZE RN / CCPZP RN	40 A / 16 A / 10 A	F.42-43
	- CIPZ D	5 A	F.44-45
	- CIPZP D	5 A	F.46
<hr/>			
	Square profile		
	- CXPZ TP	40 A	F.47
	- CCPZ TP	16 A / 10 A	F.47
<hr/>			
	Stamped contacts		
	- SDPZ TP	10 A	F.48
	- SIPZ W / SIPZC W	5 A	F.49
<hr/>			
	Automatic machines		
	- ZFU-CD	16 A / 10 A	F.50-51
	- SDPZP Z	10 A	F.52
	- SIPZP Z	5 A	F.53
<hr/>			
Other tools	Removal tools		F.54-61
	Punching tools		F.62-63
	<hr/>		
Data connectors tools	- CJPZ Y	RJ45 CAT 5	F.64
	- CJPZ T	RJ45 CAT 6A	F.65
	- CJPW K	for MIXO CX 08 J6I	F.66
	- COPZ	Coaxial RF contacts	F.67
	- CLPZ R	POF Fibre Optic	F.68-71

C13PZ C

for 300 A crimp contacts

Hex profile



Item	Description	Part No.	Technical informations:
	Manual hydraulic crimping tool for 300 A C30 series contacts mod. CEMBRE HT 131-C	C13PZ C	<ul style="list-style-type: none"> - Crimping force 130 kN - Rated operating pressure: 700 bar - Dimensions: 473 × 144 mm - Weight: 5,5 kg - Operating temperature: -15 °C to +50 °C
	Crimping dies according to DIN 46235 for 300 A C30 contacts with 16 mm ² (AWG 6) wire cross-section with 25 mm ² (AWG 4) wire cross-section with 35 mm ² (AWG 2) wire cross-section with 50 mm ² (AWG 1) wire cross-section with 70 mm ² (AWG 2/0) wire cross-section with 95 mm ² (AWG 3/0) wire cross-section with 120 mm ² (AWG 4/0) wire cross-section	C13D 16 C C13D 25 C C13D 35 C C13D 50 C C13D 70 C C13D 95 C C13D 120 C	

Tool information

Part No.	Cembre part No.	Pressing width (mm)	Punching identification	Contacts	Wire cross-section	
					mm ²	AWG
C13D 16 C	MK8-C	10	K8	C30MA 16, C30MA 16 P, C30FA 16	16	6
C13D 25 C	MK10-C	10	K10	C30MA 25, C30MA 25 P, C30FA 25	25	4
C13D 35 C	MK12-C	10	K12	C30MA 35, C30MA 35 P, C30FA 35	35	2
C13D 50 C	MK14-C	13	K14	C30MA 50, C30MA 50 P, C30FA 50	50	1
C13D 70 C	MK16-C	13	K16	C30MA 70, C30MA 70 P, C30FA 70	70	2/0
C13D 95 C	MK18-C	14	K18	C30MA 95, C30MA 95 P, C30FA 95	95	3/0
C13D 120 C	MK20-C	14	K20	C30MA 120, C30MA 120 P, C30FA 120	120	4/0



Contacts	Pages
C30	300 A F.6

C13PZE C

for 300 A crimp contacts

Hex profile



Item	Description	Part No.	
	Battery operated hydraulic crimping tool for 300 A C30 series contacts mod. CEMBRE B1350-C for EU for UK for AUS for US/CAN	C13PZE C EU C13PZE C UK C13PZE C AU C13PZE C US	<p>Technical informations:</p> <ul style="list-style-type: none"> - Crimping force 132 kN - Minimum operating pressure 692 bar - Dimensions: 338 × 344 × 83 mm - Weight (with battery): 6,5 kg - Operating temperature: -15 °C to +50 °C
	Crimping dies according to DIN 46235 for 300 A C30 contacts with 16 mm ² (AWG 6) wire cross-section with 25 mm ² (AWG 4) wire cross-section with 35 mm ² (AWG 2) wire cross-section with 50 mm ² (AWG 1) wire cross-section with 70 mm ² (AWG 2/0) wire cross-section with 95 mm ² (AWG 3/0) wire cross-section with 120 mm ² (AWG 4/0) wire cross-section	C13D 16 C C13D 25 C C13D 35 C C13D 50 C C13D 70 C C13D 95 C C13D 120 C	<p>Battery informations:</p> <ul style="list-style-type: none"> - Type CB1852L (Li-Ion) 18 V, 5,2 Ah, 93.6 Wh - Weight: 0,66 kg - Battery charger input: 220 V-240 V / 50-60 Hz (EU, UK, AU) - Battery charger input: 115 V / 60 Hz (US)



Tool information

Part No.	Cembre part No.	Pressing width (mm)	Punching identification	Contacts	Wire cross-section	
					mm ²	AWG
C13D 16 C	MK8-C	10	K8	C30MA 16, C30MA 16 P, C30FA 16	16	6
C13D 25 C	MK10-C	10	K10	C30MA 25, C30MA 25 P, C30FA 25	25	4
C13D 35 C	MK12-C	10	K12	C30MA 35, C30MA 35 P, C30FA 35	35	2
C13D 50 C	MK14-C	13	K14	C30MA 50, C30MA 50 P, C30FA 50	50	1
C13D 70 C	MK16-C	13	K16	C30MA 70, C30MA 70 P, C30FA 70	70	2/0
C13D 95 C	MK18-C	14	K18	C30MA 95, C30MA 95 P, C30FA 95	95	3/0
C13D 120 C	MK20-C	14	K20	C30MA 120, C30MA 120 P, C30FA 120	120	4/0


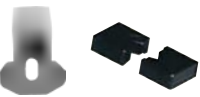

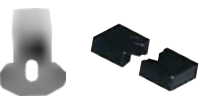

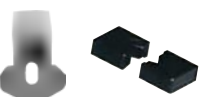


Contacts	Pages
C30	300 A F.6

CPPZ C

for 200 A / 100 A / 70 A crimp contacts for CGT PE terminal adapters

Hex profile



Item	Description	Part No.
	Manual crimping tool for 200 A, 100 A and 70 A contacts, CEMBRE HT 45 model case included (positioner and crimping dies excluded)	CPPZ C
	Positioner insert for CY contacts	CYPZ LOC
	Crimping dies for CY contacts 16 mm ² (AWG 6) 25 mm ² (AWG 4) 35 mm ² (AWG 2) 50 mm ² (AWG 1) 70 mm ² (AWG 2/0)	CGD 25 C CYD 35 C CYD 35 C CYD 50 C CYD 70 C
	Positioner insert for CG contacts	CGPZ LOC
	Crimping dies for CG contacts 10 mm ² (AWG 8-7) 16 mm ² (AWG 6-5) 25 mm ² (AWG 4-3) 35 mm ² (AWG 2)	CGD 10 C CGD 16 C CGD 25 C CGD 35 C
	Positioner insert for CX7/RX7 contacts	CX7PZ LOC
	Crimping dies for CX7/RX7 contacts 6 mm ² (AWG 10) 10 mm ² (AWG 8-7) 16 mm ² (AWG 6-5) 25 mm ² (AWG 4-3)	CGD 10 C CGD 10 C CGD 16 C CGD 25 C
	Crimping dies for PE terminal adapters CGT 6.0 6 mm ² (AWG 10) CGT 10 10 mm ² (AWG 8-7) CGT 16 16 mm ² (AWG 6-5) CGT 25 25 mm ² (AWG 4-3)	CGD 10 C CGD 10 C CGD 16 C CGD 25 C

Crimping dies information

Part No.	Cembre Part No.	Pressing width (mm)	Punching identification	Contacts	mm ²	AWG	
						min	max
CGD 10 C	ME2	7	A2	CX7MA 6.0, CX7MA 6.0 P, CX7FA 6.0, RX7M2D 6.0, RX7M2D 6.0 P, RX7F2D 6.0, CGT 6.0	6	—	10 (5,26)
		7			10	8 (8,4)	7 (10,6)
CGD 16 C	ME3	7	A3	CX7MA 16, CX7MA 16 P, CX7MA 16 XF, CX7MA 16 XFP, CX7FA 16, CX7FA 16 XF, CGT 16	16	6 (13,3)	5 (16,8)
		7					
CGD 25 C	ME5	7	A5	CX7MA 25, CX7MA 25 P, CX7FA 25, RX7M2D 25, RX7M2D 25 P, RX7F2D 25, CGT 25	25	4 (21,2)	3 (26,7)
CGD 10 C	ME2	7	A2	CGMA 10, CGFA 10	10	8 (8,4)	7 (10,6)
CGD 16 C	ME3	7	A3	CGMA 16, CGFA 16	16	6 (13,3)	5 (16,8)
CGD 25 C	ME5	7	A5	CGMA 25, CGFA 25	25	4 (21,2)	3 (26,7)
CGD 35 C	ME7	7	A7	CGMA 35, CGFA 35	35	—	2 (33,6)
CGD 25 C	ME5	7	A5	CYMA 16, CYFA 16	16	—	6 (13,3)
CYD 35 C	ME9	7	A9	CYMA 35, CYFA 35	35	—	2 (33,6)
CYD 50 C	ME12	7	A12	CYMA 50, CYFA 50	50	—	1 (42,4)
CYD 70 C	ME17	7	A17	CYMA 70, CYFA 70	70	—	2/0 (67,4)

Contacts	Pages
CY 200 A	F.7
CG 100 A	F.8
CX7 / RX7 HNM 70 A	F.9



Tutorial

CPPZ C

use and maintenance instructions

1. General specifications

The **CPPZ C crimping tool** is a hydraulically operated tool suitable for manually crimping contact series (70A/100A/200A max) removable crimp contacts which may be used in **MIXO** series type **CX7**, **CG**, **CY** and **CGT** adapters. By using a suitable, hexagonal footprint crimp matrix pair, these pliers allow crimped connections to be made which conform to the highest quality standards.

The main features of these pliers are listed below:

- Scope of application: suitable for crimping wire terminals for up to 150 mm² flexible copper wires.
- Force developed: 50 kN (6 tons).
- Nominal operating pressure: 600 bar (8.700 psi).
- Dimensions: length 346 mm (13,6");
 - width (locked moving handle) 130 mm (5,1");
 - width (free moving handle) 250 mm (9,8").
- Weight: (without matrixes and without ILME locator) 2,0 kg (4,4 lbs).
- Recommended oil: ENI ARNICA ISO32 or SHELL TELLUS S2 V 32 or equivalent.
- Other features: please read the user and maintenance manual supplied with the tool.

The pliers are equipped with a locator specifically designed for ILME crimp contacts to be mounted on the moving part of the pliers head by means of the Allen screw provided.

NOTE: It is possible to use the CPPZ C pliers with the CX7 70 A, CG 100 A and CY 200 A contact series, by simply fitting the CX7PZ LOC, CGPZ LOC or CYPZ LOC locator and crimping matrixes to be purchased separately.

WARNING: For crimping the CGT adapters, the crimp locating operation must be carried out by the user.

2. Preliminary operations

According to requirements, the pliers can be fitted with one or more pairs of crimp matrixes selected from the matrixes listed in the catalogue, to crimp the contacts shown in the table page F.26.

NOTE: The crimp contacts are only suitable for crimping flexible copper wires featuring a nominal section shown in the table with the crimp matrixes shown in the table. Any contacts – wires – matrixes combination which does not conform to these instructions is not physically possible (ex: using 35 mm² contacts with CGD 25 C matrixes is not possible because the pliers head would not close) or produces non conforming crimped connections or not usable in the MIXO series.

Open the tool head by moving the matrix supporting hook ③ outwards until the matrix support ① is released.

With reference to **Figures 1 and 2**, select a pair of matrixes suitable to the type of contact and insert them in the housings: one in the matrix support ①, the other one in the matrix pusher support ②. (NB: the two matrixes of each pair are the same).

Insert the contact by resting it in the locator with the tip forward, then close the head.

The contact crimp housing will be accessible in the mouth between the matrixes.

Remove the moving handle ④ by removing the handle locking belt from the handle.

Before carrying out the next operations, make sure the head is fully closed to avoid damages.

The pliers head can rotate by 180° in relation to the body, thus allowing the operator to work in the most comfortable position.

WARNING: do not force the head by trying to rotate it when the tool is under pressure.

3. Approaching the matrixes

If possible closing the dies, rest the pliers head on a work top, then move the moving handle to start moving the matrixes closer to the contact, then carry on moving them until the contact is locked between the matrixes.

Push the correctly stripped and suitable long (**15 mm**) wire all the way in the contact (or the CGT adapters) crimp housing by carefully checking that the braids are fully compacted, are not damaged and, above all, are all fully inserted.

Correctly pushing the contact in the locator ensures that the matrixes are exactly in the right area to compress (the contact crimp shaft centre). Make sure that the locator is free from any residue which would alter the position of the contact. For crimping the CGT 16 earth adapter, manually locate the area to be crimped between the matrixes. If necessary, re-open the matrixes by following the instructions described in paragraph 4 and reposition the contact.

4. Crimping

Continue to operate the moving handle (pumping): the piston will gradually move forward until the matrixes come into contact. Continue the pumping action until the maximum pressure valve clicks in.

5. Releasing the dies

Fully press the pressure release lever ⑤ located on the pliers pumping body until the piston goes back and the matrixes open. To remove the crimped contact, re-open the pliers head.

6. Storage

Fully return the piston as described in paragraph 4, then lock the moving handle in position by using the belt provided.

7. Cleaning and maintenance

The tool is very sturdy and does not require any special care; a correct operation is ensured by following a few simple precautions.

The tool is supplied with a user and maintenance manual, which gives all detailed instructions. Read this manual before use.

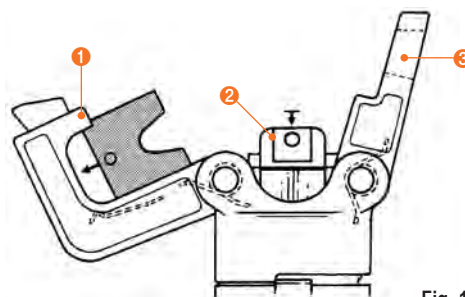


Fig. 1

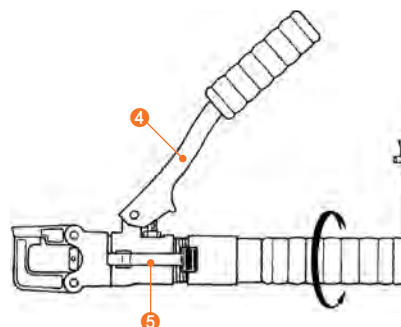


Fig. 2

CGPZ VLG carrying case

- for CPPZ C* crimping tool
- dimensions 445 x 290 x h 95 mm
- weight 1,2 kg
- houses 20 pairs of matrixes

* to store the CPPZ C crimping tool inside the carrying case, turn the pliers head by 180° so that the locator becomes visible.












NOTE: Part No. CPPZ CF tool case kit. Manual crimping tools carrying case (CGPZ VLG) complete with crimping tool (CPPZ C), crimping dies (CGD/CYD) and locator (CX7PZ LOC, CGPZ LOC, CYPZ LOC).

CPPZE C

for 200 A / 100 A / 70 A crimp contacts

Hex profile



Item	Description	Part No.	
	Battery operated hydraulic crimping tool for 200 A, 100 A and 70 A contacts mod. CEMBRE B450ND-BV for EU for UK for AUS for US/CAN case included (positioner and crimping dies excluded)	CPPZE C EU CPPZE C UK CPPZE C AU CPPZE C US	Technical informations: - Crimping force: 50 kN - Minimum operating pressure: 600 bar - Dimensions: 364 x 126 x 79 mm - Weight: 2,6 kg (with battery) - Operating temperature: -15 to +50 °C
	Positioner insert for CY contacts	CYPZ LOC	
	Crimping dies for CY contacts 16 mm ² (AWG 6) 25 mm ² (AWG 4) and 35 mm ² (AWG 2) 50 mm ² (AWG 1) 70 mm ² (AWG 2/0)	CGD 25 C CYD 35 C CYD 50 C CYD 70 C	
	Positioner insert for CG contacts	CGPZ LOC	
	Crimping dies for CG contacts 10 mm ² (AWG 8-7) 16 mm ² (AWG 6-5) 25 mm ² (AWG 4-3) 35 mm ² (AWG 2)	CGD 10 C CGD 16 C CGD 25 C CGD 35 C	
	Positioner insert for CX7/RX7 contacts	CX7PZ LOC	
	Crimping dies for CX7/RX7 contacts 6 mm ² (AWG 10) 10 mm ² (AWG 8-7) 16 mm ² (AWG 6-5) 25 mm ² (AWG 4-3)	CGD 10 C CGD 10 C CGD 16 C CGD 25 C	
	Crimping dies for PE terminal adapters CGT 6.0 6 mm ² (AWG 10) CGT 10 10 mm ² (AWG 8-7) CGT 16 16 mm ² (AWG 6-5) CGT 25 25 mm ² (AWG 4-3)	CGD 10 C CGD 10 C CGD 16 C CGD 25 C	

Crimping dies information

Part No.	Cembre Part No.	Pressing width (mm)	Punching identification	Contacts	mm ²	AWG	
						min	max
CGD 10 C	ME2	7	A2	CX7MA 6.0, CX7MA 6.0 P, CX7FA 6.0, RX7M2D 6.0, RX7M2D 6.0 P, RX7F2D 6.0, CGT 6.0	6	—	10 (5,26)
		7			10	8 (8,4)	7 (10,6)
CGD 16 C	ME3	7	A3	CX7MA 16, CX7MA 16 P, CX7FA 10, RX7M2D 10, RX7M2D 10 P, RX7F2D 10, CGT 10 RX7M2D 16, RX7M2D 16 P, RX7M2D 16 XF, RX7M2D 16 XF, RX7F2D 16, RX7F2D 16 XF	16	6 (13,3)	5 (16,8)
		7			25	4 (21,2)	3 (26,7)
CGD 10 C	ME2	7	A2	CGMA 10, CGFA 10	10	8 (8,4)	7 (10,6)
CGD 16 C	ME3	7	A3	CGMA 16, CGFA 16	16	6 (13,3)	5 (16,8)
CGD 25 C	ME5	7	A5	CGMA 25, CGFA 25	25	4 (21,2)	3 (26,7)
CGD 35 C	ME7	7	A7	CGMA 35, CGFA 35	35	—	2 (33,6)
CGD 25 C	ME5	7	A5	CYMA 16, CYFA 16	16	—	6 (13,3)
					25	—	4 (21,2)
CYD 35 C	ME9	7	A9	CYMA 25, CYFA 25 CYMA 35, CYFA 35	25	—	4 (21,2)
					35	—	2 (33,6)
CYD 50 C	ME12	7	A12	CYMA 50, CYFA 50	50	—	1 (42,4)
CYD 70 C	ME17	7	A17	CYMA 70, CYFA 70	70	—	2/0 (67,4)

Contacts		Pages
CY	200 A	F.7
CG	100 A	F.8
CX7 / RX7 HNM	70 A	F.9

CPPZEH C

for 200 A / 100 A / 70 A crimp contacts

Hex profile



Item	Description	Part No.	
	Battery operated hydraulic crimping tool for 200 A, 100 A and 70 A contacts mod. CEMBRE B500 for EU for UK for AUS for US/CAN case included (positioner and crimping dies excluded)	CPPZEH C EU CPPZEH C UK CPPZEH C AU CPPZEH C US	Technical informations: - Crimping force: 63 kN - Minimum operating pressure: 661 bar - Dimensions: 300 x 343 x 83 mm - Weight: 4,2 kg (with battery) - Operating temperature: -15 to +50 °C
	Positioner insert for CY contacts Crimping dies for CY contacts 16 mm ² (AWG 6) 25 mm ² (AWG 4) and 35 mm ² (AWG 2) 50 mm ² (AWG 1) 70 mm ² (AWG 2/0)	CYPZEH LOC CGD 25EH C CYD 35EH C CYD 50EH C CYD 70EH C	Battery informations: - Rechargeable battery: 18 V / 5,2 Ah / 93,6 Wh - Battery charger input: 220-240 V / 50-60 Hz (EU, UK, AU) - Battery charger input: 115 V / 60 Hz (US) - Type: CB1852L (Li-Ion) - Weight: 0,66 kg
	Positioner insert for CG contacts Crimping dies for CG contacts 10 mm ² (AWG 8-7) 16 mm ² (AWG 6-5) 25 mm ² (AWG 4-3) 35 mm ² (AWG 2)	CGPZEH LOC CGD 10EH C CGD 16EH C CGD 25EH C CGD 35EH C	
	Positioner insert for CX7/RX7 contacts Crimping dies for CX7/RX7 contacts 6 mm ² (AWG 10) 10 mm ² (AWG 8-7) 16 mm ² (AWG 6-5) 25 mm ² (AWG 4-3)	CX7PZEH LOC CGD 10EH C CGD 10EH C CGD 16EH C CGD 25EH C	
	Crimping dies for PE terminal adapters CGT 6.0 6 mm ² (AWG 10) CGT 10 10 mm ² (AWG 8-7) CGT 16 16 mm ² (AWG 6-5) CGT 25 25 mm ² (AWG 4-3)	CGD 10EH C CGD 10EH C CGD 16EH C CGD 25EH C	

Crimping dies information

Part No.	Cembre Part No.	Pressing width (mm)	Punching identification	Contacts	mm ²	AWG	
						min	max
CGD 10EH C	ME2-50	7	A2	CX7MA 6.0, CX7MA 6.0 P, CX7FA 6.0, RX7M2D 6.0, RX7M2D 6.0 P, RX7F2D 6.0	6	—	10 (5,26)
		7			10	8 (8,4)	7 (10,6)
CGD 16EH C	ME3-50	7	A3	CX7MA 16, CX7MA 16 P, CX7MA 16 XF, CX7MA 16 XFP, CX7FA 16, CX7FA 16 XF RX7M2D 16, RX7M2D 16 P, RX7M2D 16 XF, RX7M2D 16 XFP, RX7F2D 16, RX7F2D 16 XF	16	6 (13,3)	5 (16,8)
		7			25	4 (21,2)	3 (26,7)
CGD 10EH C	ME2-50	7	A2	CGMA 10, CGFA 10	10	8 (8,4)	7 (10,6)
CGD 16EH C	ME3-50	7	A3	CGMA 16, CGFA 16	16	6 (13,3)	5 (16,8)
CGD 25EH C	ME5-50	7	A5	CGMA 25, CGFA 25	25	4 (21,2)	3 (26,7)
CGD 35EH C	ME7-50	7	A7	CGMA 35, CGFA 35	35	—	2 (33,6)
CGD 25EH C	ME5-50	7	A5	CYMA 16, CYFA 16	16	—	6 (13,3)
					25	—	4 (21,2)
CYD 50EH C	ME12-50	7	A12	CYMA 50, CYFA 50	50	—	1 (42,4)
CYD 70EH C	ME17-50	7	A17	CYMA 70, CYFA 70	70	—	2/0 (67,4)




Contacts	Pages
CY 200 A	F.7
CG 100 A	F.8
CX7 / RX7 HNM 70 A	F.9

CXPZ D

for 40 A crimp contacts

MIL profile



Item	Description	Part No.
	Manual crimping tool for 40 A contacts up to size 6.0 DANIELS M309 model (turret excluded) With crimping depth adjuster dial selector	CXPZ D
	Positioner for 40 A contacts (CX and RX HNM series) It precisely positions the contact where crimping is performed. Each series of contacts requires its own turret.	CXTP 40
	"Go/no go" control gauge, to verify indenter closure To be used to periodically check that the crimping tool meets standard requirements.	CXPNP

40 A contact head turret/positioner

CX/RX series		1,5 mm ²	2,5 mm ²	4,0 mm ²	6,0 mm ²	10 mm ²	conductor section AWG
male	female	16	14	12	10	8	
1,5	1,5	5					M309
2,5	2,5		5				
4,0	4,0			6			
6,0	6,0				7		
10	10					8	WA-27-309-EP

TOOLS

F

Contacts	Pages
CX / RX HNM 40 A	F.10

CXPZ D

use and maintenance instructions

1. General specifications

The CXPZ D crimping tool performed with 8 pressure points. The tool is equipped with a geared mechanism to control the complete crimping cycle.

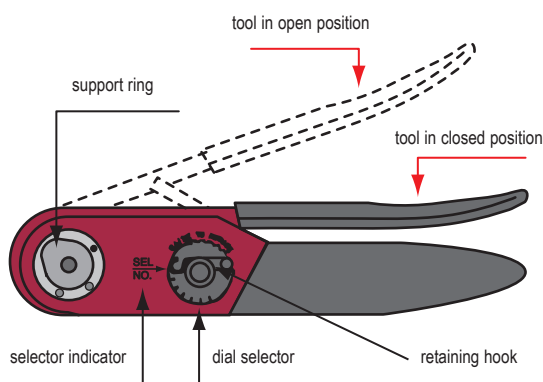
The tool must be equipped with an interchangeable turret (CXTP) according to the series of contacts to be crimped.

1.1 Crimping range

Conductor cross-sectional area range: from 1,5 mm² (16 AWG) to 6 mm² (10 AWG).

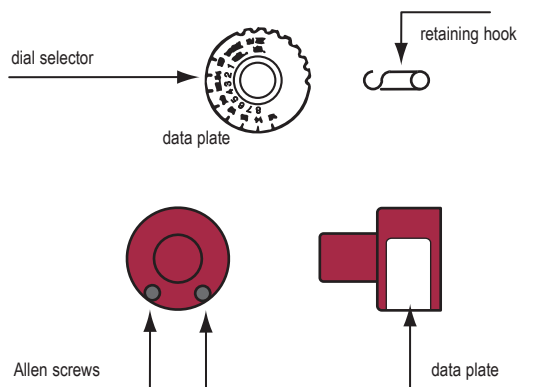
Caution!

The handle of the tool must be in the open position when the turret is installed, disassembled or opened. If not, the turret and the crimping tool may be damaged.



2. CXTP positioner installation

- 1 The crimping tool must be in the open position.
- 2 Position the CXTP 40 positioner on the support ring located on the crimping tool (matching the special pin on the base of the turret with the corresponding hole on the support ring), aligning the tapped holes with the socket head screws.
- 3 With the CXTP 40 positioner positioned against the support ring, tighten the socket head screws with the 9/64" (3,5 mm) Allen wrench (supplied with the kit).
- 4 Refer to the data plate on the CXTP 40 positioner. From the column indicating the proper conductor cross-sectional area, determine the number that corresponds to the contact being used.
- 5 Remove the retaining hook from the crimping tool dial selector. Lift the dial selector and turn it until the selector number is aligned with the indicator (SEL.NO.). Replace the retaining hook (if necessary).



3. Crimping instructions

- 1 Insert the contact and the prepared* conductor through the opening of the indenter in the turret positioner.
- 2 Tighten the crimping tool handle until the stop gear is released. The tool will return to the open position.
- 3 Check the position of the crimping on the contact crimping foot. Ideally, the crimping should be between the inspection hole and the top edge of the crimping foot.
The head of the contact should not be squared and the inspection hole should be intact.

* i.e. stripped at the correct length and with strands lightly twisted to recover regular lay of strands

4. Removing the CXPT positioner

With the crimping tool in the open position, to disassemble the turret, loosen the socket head screws using the 9/64" (3,5 mm) Allen wrench (supplied with the kit). After the threads are released from the support ring, pull off the positioner with a straight movement.

5. Instructions to check calibration

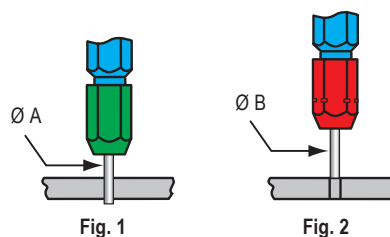
The operations to check the crimping tool must be carried out with the dial selector in position 4 and with the CXPNP gauge (formerly Daniels G425, now Daniels G436 or G1004 which are equivalent for the purpose). **ATTENTION! Do not crimp the gauge.**

5.1 Calibration check

- Put the crimping tool in the completely closed position.
- "GO" - Insert the end (green) of the gauge as shown (Fig. 1). The gauge must pass freely between the indenter tips.
- "NO GO" - Insert the end (red) of the gauge as shown (Fig. 2). The gauge should not pass through the opening.

"Go / no go" control gauge information

Gauge	Tool selector pos. No	Ø A ± 0,00254 (GO) green	Ø B ± 0,00254 (NO GO) red
CXPNP	4	1,549 (mm) 0,0609 (in)	1,676 (mm) 0,0659 (in)



6. Crimping tool maintenance


No maintenance is required. However, it is good practice to keep the indenter tips free from residual deposits of the coloured band (some types of crimp contacts as per MIL standards are identified by coloured bands in the crimping area) and any other debris. A metal brush may be used for this purpose. The following is strongly recommended:






- 1 DO NOT immerse the tools in a solution to clean them.
- 2 DO NOT brush oil in the tools to lubricate them.
- 3 DO NOT try to disassemble the tool or repair it.

This is a high-precision manual crimping tool and must be used as such.

CXPZP D

for 40 A crimp contacts

MIL profile 

Item	Description	Part No.
	Pneumatic crimping tool for 40 A contacts model DANIELS WA27-309-EP supplied with bench support CCSPZP and pneumatic foot valve CCVPP (positioner CXTP 40 and control gauge CXPNPP are optional)	CXPZP D
	Positioner for 40 A contacts (CX and RX HNM series) It precisely positions the contact where crimping is performed. Each series of contacts requires its own turret.	CXTP 40
	"Go/no go" control gauge to verify indenter closure To be used to periodically check that the crimping tool meets standard requirements.	CXPNPP
	Already included in CXPZP D Bench support for CCPZP D pneumatic crimping tool (DANIELS BM-2A)	CCSPZP
	Pneumatic foot valve (DANIELS WA10A)	CCVPP

40 A contact head turret/positioner

CX/RX series		1,5 mm ²	2,5 mm ²	4,0 mm ²	6,0 mm ²	10 mm ²	conductor section AWG
male	female	16	14	12	10	8	M309
1,5	1,5	5					
2,5	2,5		5				
4,0	4,0			6			
6,0	6,0				7		
10	10					8	WA-27-309-EP

Contacts	Pages
CX / RX HNM 40 A	F.10

TOOLS

F

CXPZP D

use and maintenance instructions

1. General specifications

This is the pneumatic version of the CXPZ D hand crimping tool (DANIELS M309). Crimping is performed with 8 pressure points. The tool is equipped with a geared mechanism to control the complete crimping cycle.

The tool must be equipped with the interchangeable positioner CXTP 40 suitable for series CX (or RX HNM version) crimp contacts.

The tool comes already equipped with a pneumatic foot pedal valve (WA10A) attached to the tool through 2,7 m (9 ft.) air hose.

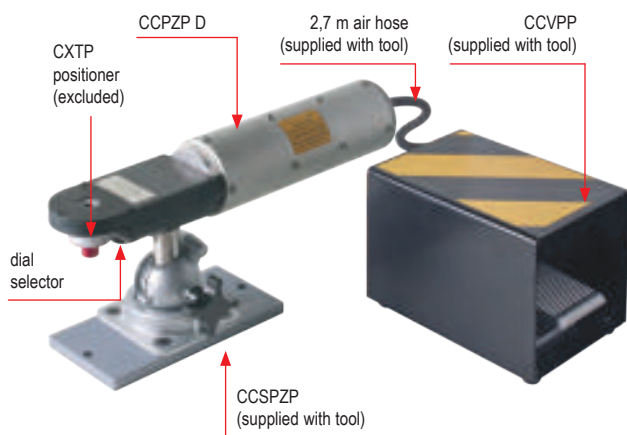
The tool operating pressure is 5,5 – 8,3 bar. It is recommended to utilise a lubrication, adjustment and air filtering unit.

1.1 Crimping range

Conductor cross-sectional area range: from 1,5 mm² (16 AWG) to 10 mm² (8 AWG).

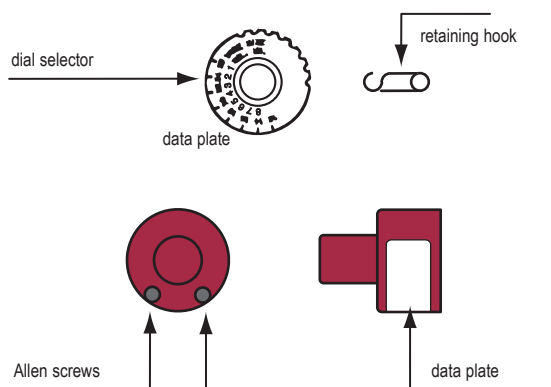
1.2 Operation with pneumatic foot valve (supplied with tool)

Connect the foot valve between the compressed air source and the tool air inlet.



2. CXTP 40 positioner installation

- Place the CXTP 40 positioner on the support ring located on the crimping tool (matching the special pin on the base of the turret with the corresponding hole on the support ring), aligning the tapped holes with the socket head screws.
- With the CXTP 40 positioner places against the support ring, tighten the socket head screws with the 9/64" (3,5 mm) Allen wrench (supplied with the kit).
- Refer to the dataplate on the CXTP 40 positioner. From the column indicating the proper conductor cross-sectional area, determine the number that corresponds to the contact being used.
- Remove the retaining hook from the crimping tool dial selector. Lift the dial selector and turn it until the selector number is aligned with the indicator (SEL.NO.). Replace the retaining hook (if necessary).



3. Checking the crimping complete cycle ratcheting control mechanism

Correct operation can be checked based on the following procedure:

- Install the CXTP 40 positioner (see paragraph 2).
- Reduce the pressure to 1 bar.
- Using a series CX contact that corresponds to the installed turret, e.g. size 1.5, and a wire with cross-sectional area 1.5 mm² (16 AWG) use the crimping tool, referring to the crimping instructions. The indenters will not reach the fully closed position and the contact will be internally blocked if the geared mechanism is operating correctly.
- To release the partially crimped contact, increase the air pressure of the line to 5,5 – 8,3 bar and again use the crimping tool. It will then complete the crimping, allowing the indenters to return to the fully open position.

4. Removing the CXPT 40 positioner

With the crimping tool in the open position, to disassemble the positioner, loosen the socket head screws using the 9/64" (3,5 mm) Allen wrench (supplied with the kit). After the threads are released from the support ring, pull off the positioner with a straight movement.

5. Releasing a partially crimped contact

To release a partially crimped contact, do the following:

- Increase the air pressure to 8.5 bar and use the crimping tool. If the increase in air pressure does not release the contact, do the following.
- Turn the dial selector clockwise to the highest lockable setting (the dial selector must be in the blocked position before continuing). Use the crimping tool.
- If it does not release after several attempts, contact the ILME offices.

6. Crimping instructions

- Insert the contact and the prepared conductor through the opening of the indenter in the turret positioner.
- Activate the hand valve or the foot valve. Once crimping has been completed, the tool will return to the open position.
- Check the position of the crimping on the contact crimping foot. Ideally, the crimping should be between the inspection hole and the top edge of the crimping foot. The head of the contact should not be squared and the inspection hole should be intact.

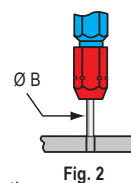
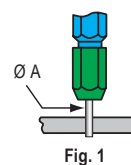
7. Instructions to check calibration

The operations to check the crimping tool must be carried out with the dial selector in **position 5** and the **CXPNPP** gauge (DANIELS G1005 – formerly G425, which is equivalent).

CAUTION! Do not crimp the gauge.

7.1 Calibration check

- Put the crimping tool in the completely closed position.
- “GO” - Insert the end (green) of the gauge as shown (Fig. 1). The gauge must pass freely between the indenter tips.
 - “NO GO” - Insert the end (red) of the gauge as shown (Fig. 2). The gauge should not pass through the opening.



“Go / no go” control gauge information

Gauge	Tool selector pos. No	∅ A ± 0,00254 (GO) green	∅ B ± 0,00254 (NO GO) red
CXPNPP	5	1,7526 (mm) 0,069 (in)	1,8796 (mm) 0,074 (in)

8. Crimping tool maintenance

No maintenance is required. However, it is good practice to keep the indenter tips free from residual deposits of the coloured band (some types of crimp contacts as per MIL standards are identified by coloured bands in the crimping area) and any other debris. A metal brush may be used for this purpose.

- The following is strongly recommended:
- DO NOT immerse the tools in a solution to clean them.
 - DO NOT brush oil in the tools to lubricate them.
 - DO NOT try to disassemble the tool or repair it.




This is a high-precision crimping tool and must be used as such.

CCPZ MIL

for 16 A / 10 A crimp contacts

MIL profile



Item	Description	Part No.
	Manual crimping tool for 10/16 A contacts DANIELS AF8 model (turret excluded) With crimping depth adjuster dial selector	CCPZ MIL
	Positioner inserts for 10 A contacts (CD and RD HNM series)	CCTP 10
	Positioner inserts for 16 A contacts (CC and RC HNM series)	CCTP 16
	Conforms to international standard MIL-C-22520/1. It precisely positions the contact where crimping is performed. Each series of contacts requires its own turret.	
	"Go/no go" control gauge, to verify indenter closure	CCPNP
	Conforms to international standard MIL-C-22520/3. To be used to periodically check that the crimping tool meets standard requirements.	

10 A contact head turret/positioner

CD/RD series		0,14 mm ²	0,25 mm ²	0,34 mm ²	0,5 mm ²	0,75 mm ²	1,0 mm ²	1,5 mm ²	2,5 mm ²	conductor section AWG
red (male)	blue (female)	26	24	22	20	18	17	16	14	crimping depth adjuster selection CCTP-10
0,3	0,3	5	5	6						
0,5	0,5				6					
0,7	0,7					6				
1,0	1,0						6			
1,5	1,5							7		
2,5	2,5								7	

16 A contact head turret/positioner

CC/RC series		0,14 mm ²	0,25 mm ²	0,34 mm ²	0,5 mm ²	0,75 mm ²	1,0 mm ²	1,5 mm ²	2,5 mm ²	3,0 mm ²	4,0 mm ²	conductor section AWG
red (male)	blue (female)	26	24	22	20	18	17	16	14	12	12	crimping depth adjuster selection CCTP-16
0,3	0,3	5	5	6								
0,5	0,5		6	6	7							
0,7	0,7			6	6	7						
1,0	1,0			6	6	7	7					
1,5	1,5				6	7	7	8				
2,5	2,5					6	6	7	7			
3,0	3,0							6	7	7		
4,0	4,0									7	8	

Contacts		Pages
CC / RC HNM	16 A	F.11-13
CD / RD HNM	10 A	F.14-16



Tutorial

CCPZ MIL

use and maintenance instructions

1. General specifications

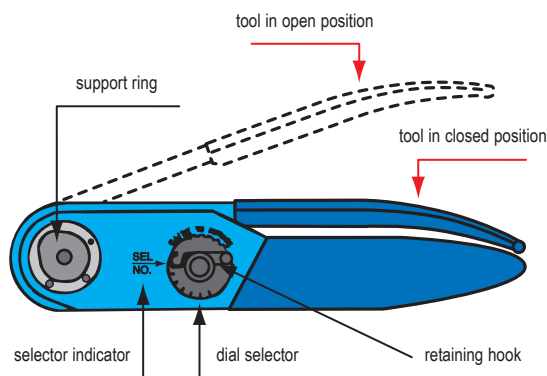
The **CCPZ MIL crimping tool** conforms to the international standard MIL-C-22520/1. Crimping is performed with 8 pressure points. The tool is equipped with a geared mechanism to control the complete crimping cycle. **The tool must be equipped with an interchangeable positioner (CCTP) according to the series of contacts to be crimped.**

1.1 Crimping range

Conductor cross-sectional area range:
 from 0,14 mm² (26 AWG) to 4 mm² (12 AWG) for positioner 16 A,
 from 0,14 mm² (26 AWG) to 2,5 mm² (14 AWG) for positioner 10 A

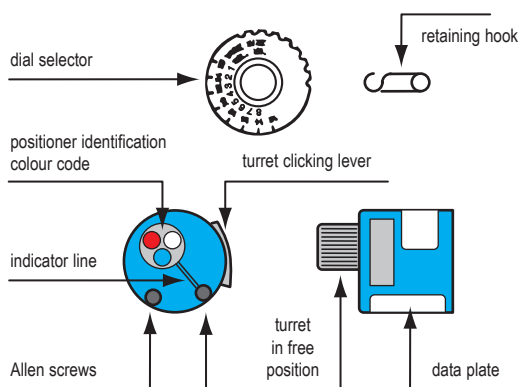
Caution!

The handle of the tool must be in the open position when the turret is installed, disassembled or opened. If not, the turret and the crimping tool may be damaged.



2. CCTP positioner installation

- 1 The crimping tool must be in the open position.
- 2 Press the clicking lever that releases the positioner in the adjustment position.
- 3 Position the previously selected CCTP positioner on the support ring located on the crimping tool (matching the special pin on the base of the turret with the corresponding hole on the support ring), aligning the tapped holes with the socket head screws.
- 4 With the CCTP positioner positioned against the support ring, tighten the socket head screws with the 9/64" (3,5 mm) Allen wrench (supplied with the kit).
- 5 Refer to the data plate on the CCTP positioner. From the colour code column, select the colour of the positioner that corresponds to the appropriate code and dimension of the contact to be crimped.
- 6 With the CCTP positioner in the adjustment position, turn the turret until the colour-coded positioner is aligned with the indicator line. Press the turret until it clicks into the connected position.
- 7 Refer to the data plate on the CCTP positioner. From the column indicating the proper conductor section, determine the number that corresponds to the contact being used.
- 8 Remove the retaining hook from the crimping tool dial selector. Lift the dial selector and turn it until the selector number is aligned with the indicator (SEL.NO.). Replace the retaining hook (if necessary).



3. Crimping instructions

- 1 Insert the contact and the prepared conductor through the opening of the indenter in the turret positioner.
- 2 Tighten the crimping tool handle until the stop gear is released. The tool will return to the open position.
- 3 Check the position of the crimping on the contact crimping foot. Ideally, the crimping should be between the inspection hole and the top edge of the crimping foot.
The head of the contact should not be squared and the inspection hole should be intact.

4. Removing the CCTP positioner

With the crimping tool in the open position, to disassemble the positioner, loosen the socket head screws using the 9/64" (3,5 mm) Allen wrench (supplied with the kit). After the threads are released from the support ring, pull off the positioner with a straight movement.

5. Instructions to check calibration

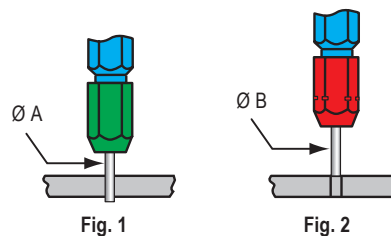
The operations to check the crimping tool must be carried out with the dial selector in position 4 and the CCPNP gauge.
ATTENTION! Do not crimp the gauge.

5.1 Calibration check

- Put the crimping tool in the completely closed position.
- “GO” - Insert the end (green) of the gauge as shown (Fig. 1). The gauge must pass freely between the indenter tips.
- “NO GO” - Insert the end (red) of the gauge as shown (Fig. 2). The gauge should not pass through the opening.

“Go / no go” control gauge information

Gauge	Tool selector pos. No	Ø A ± 0,00254 (GO) green	Ø B ± 0,00254 (NO GO) red
CCPNP	4	0,991 (mm) 0,0390 (in)	1,118 (mm) 0,0440 (in)



6. Crimping tool maintenance


- No maintenance is required.
- However, it is good practice to keep the indenter tips free from residual deposits of the coloured band (some types of crimp contacts as per MIL standards are identified by coloured bands in the crimping area) and any other debris.
- A metal brush may be used for this purpose.
- The following is strongly recommended:






- 1 DO NOT immerse the tools in a solution to clean them.
- 2 DO NOT brush oil in the tools to lubricate them.
- 3 DO NOT try to disassemble the tool or repair it.

This is a high-precision manual crimping tool and must be used as such. For automatic crimping operations refer to the CCPZP and/or CCPZPA crimping tool models.

CCPZP

for 16 A / 10 A crimp contacts

MIL profile 

Item	Description	Part No.
	Pneumatic crimping tool for 10/16 A contacts DANIELS WA27F model (turret excluded)	CCPZP
	Positioner inserts for 10 A contacts (CD and RD HNM series) Positioner inserts for 16 A contacts (CC and RC HNM series)	CCTP 10 CCTP 16
	Conforms to international standard MIL-C-22520/1. It precisely positions the contact where crimping is performed. Each series of contacts requires its own turret. "Go/no go" control gauge to verify indenter closure	CCPNP
	Conforms to international standard MIL-C-22520/3. To be used to periodically check that the crimping tool meets standard requirements. Bench support for CCPZP pneumatic crimping tool (DANIELS BM-2A)	CCSPZP
	Pneumatic foot valve (DANIELS WA10A)	CCVPP

TOOLS

F

Contacts		Pages
CC / RC HNM	16 A	F.11-13
CD / RD HNM	10 A	F.14-16



Tutorial

CCPZP

use and maintenance instructions

1. General specifications

This is the pneumatic version of the **DANIELS AF8 crimping tool (CCPZ MIL)**. Crimping is performed with 8 pressure points. The tool is equipped with a geared mechanism to control the complete crimping cycle.

The tool must be equipped with an interchangeable turret (CCTP) according to the series of contacts to be crimped.

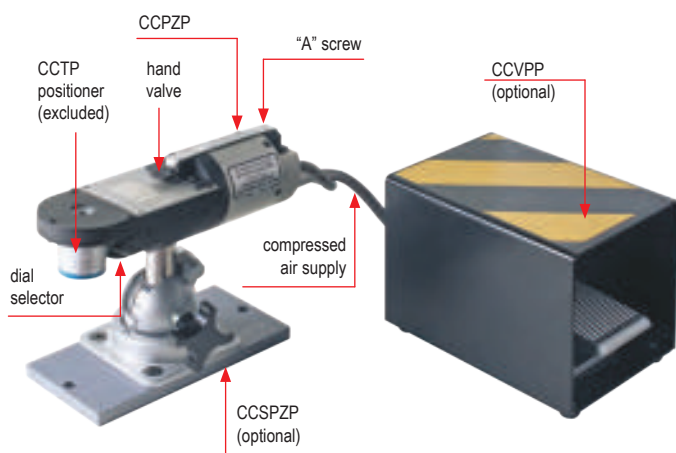
It is possible to use a hand valve (located on the crimping tool) or a foot valve (optional). The tool operating pressure is 5,5 - 8,3 bar. It is recommended to utilise an adjustment and air filtering unit.

1.1 Crimping range

Conductor cross-sectional area range: from 0,14 mm² (26 AWG) to 4 mm² (12 AWG).

1.2 Operation with pneumatic foot valve (optional)

Connect the foot valve between the compressed air source and the tool air inlet. Lower the hand valve on the tool and stop it in the lowered position with the stop "A" screw using a 1/16" (1,5 mm) Allen wrench.



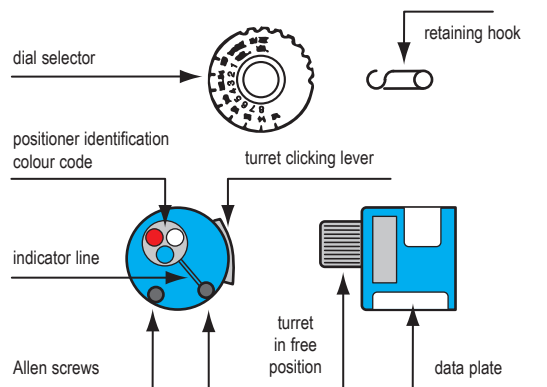
2. Checking the crimping complete cycle control mechanism

Correct operation can be checked based on the following procedure:

- 1 Install a CCTP turret (see point 3).
- 2 Reduce the pressure to 1 bar.
- 3 Using a contact that corresponds to the installed turret, with size 0,5, and a wire with section 0,5 mm², use the crimping tool, referring to the crimping instructions. The indenters will not reach the fully closed position and the contact will be internally blocked if the geared mechanism is operating correctly.
- 4 To release the partially crimped contact, increase the air pressure of the line to 5,5 - 8,3 bar and again use the crimping tool. It will then complete the crimping, allowing the indenters to return to the fully open position.

3. CCTP positioner installation (Fig. A)

- 1 Position the previously selected CCTP positioner on the support ring located on the crimping tool (matching the special pin on the base of the turret with the corresponding hole on the support ring), aligning the tapped holes with the socket head screws.
- 2 With the CCTP positioner positioned against the support ring, tighten the socket head screws with the 9/64" (3,5 mm) Allen wrench (supplied with the kit).
- 3 Refer to the data plate on the CCTP positioner. From the colour code column, select the colour of the positioner that corresponds to the appropriate code and dimension of the contact to be crimped.
- 4 With the CCTP positioner in the adjustment position, turn the turret selector until the colour-coded positioner is aligned with the indicator line. Press the turret until it clicks into the connected position.
- 5 Refer to the data plate on the CCTP positioner. From the column indicating the proper conductor section, determine the number that corresponds to the contact being used.
- 6 Remove the retaining hook from the crimping tool dial selector. Lift the dial selector and turn it until the selector number is aligned with the indicator (SEL.NO.). Replace the retaining hook (if necessary).



4. Crimping instructions

- 1 Insert the contact and the prepared conductor through the opening of the indenter in the turret positioner.
- 2 Activate the hand valve or the foot valve. Once crimping has been completed, the tool will return to the open position.
- 3 Check the position of the crimping on the contact crimping foot. Ideally, the crimping should be between the inspection hole and the top edge of the crimping foot. The head of the contact should not be squared and the inspection hole should be intact.

5. Releasing a partially crimped contact

To release a partially crimped contact, do the following:

- 1 Increase the air pressure to 8,3 bar and use the crimping tool. If the increase in air pressure does not release the contact, do the following.
- 2 Turn the dial selector clockwise to the highest lockable setting (the dial selector must be in the blocked position before continuing). Use the crimping tool.
- 3 If it does not release after several attempts, contact the ILME offices.

6. Removing the CCTP positioner

With the crimping tool in the open position, to disassemble the turret, loosen the socket head screws using the 9/64" (3,5 mm) Allen wrench (supplied with the kit).

After the threads are released from the support ring, pull off the turret with a straight movement.

7. Instructions to check calibration

The operations to check the crimping tool must be carried out with the dial selector in position 4 and the CCPNP gauge.

ATTENTION! Do not crimp the gauge.

7.1 Calibration check

Put the crimping tool in the completely closed position.

"GO" - Insert the end (green) of the gauge as shown (Fig. 1).

The gauge must pass freely between the indenter tips.

"NO GO" - Insert the end (red) of the gauge as shown (Fig. 2).

The gauge should not pass through the opening.

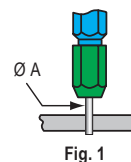


Fig. 1

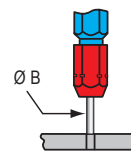


Fig. 2

"Go / no go" control gauge information

Gauge	Tool selector pos. No	Ø A ± 0,00254 (GO) green	Ø B ± 0,00254 (NO GO) red
CCPNP	4	0,991 (mm) 0,0390 (in)	1,118 (mm) 0,0440 (in)

8. Crimping tool maintenance

No maintenance is required.



However, it is good practice to keep the indenter tips free from residual deposits of the coloured band (some types of crimp contacts as per MIL standards are identified by coloured bands in the crimping area) and any other debris. A metal brush may be used for this purpose. The following is strongly recommended:

- 1 DO NOT immerse the tools in a solution to clean them.
 - 2 DO NOT brush oil in the tools to lubricate them.
 - 3 DO NOT try to disassemble the tool or repair it.
- This is a high precision crimping tool and must be used as such.

CCPZPA

for 16 A/10 A crimp contacts

MIL profile 

Item	Description	Part No.
	Pneumatic crimping tool with automatic positioner DANIELS WA27FAP model (inserts excluded)	CCPZPA
	Positioner inserts: for male 10 A contacts (CDM/RDM series) for female 10 A contacts (CDF/RDF series)	CCTPADM CCTPADF
	Positioner inserts: for male 16 A contacts (CCM/RCM series) for female 16 A contacts (CCF/RCF series)	CCTPACM CCTPACF
	It precisely positions the contact where crimping is performed. Each contact requires its own positioner insert selected according to the type of contact (10 A or 16 A) and the kind (male or female).	
	"Go/no go" control gauge to verify indenter closure	CCPNP
	To be used to periodically check that the crimping tool meets standard requirements.	

Contacts		Pages
CC / RC HNM	16 A	F.11-13
CD / RD HNM	10 A	F.14-16

CCPZPA

use and maintenance instructions

1. General specifications

This is the pneumatic version of the manual crimping tool. Crimping is performed with 8 pressure points. The tool is equipped with a geared mechanism to control the complete crimping cycle. Thanks to the automatic positioner it is possible to crimp simply by inserting the uncrimped contact + wire into the tool crimping cavity.

It is also necessary to order the interchangeable positioner inserts relative to the series of contacts to be crimped.

The tool operating pressure is 5,5 - 8,3 bar. It is recommended to utilise an adjustment and air filtering unit.

1.1 Crimping range

Conductor cross-sectional area range: from 0,12 mm² (26 AWG) to 4 mm² (12 AWG).

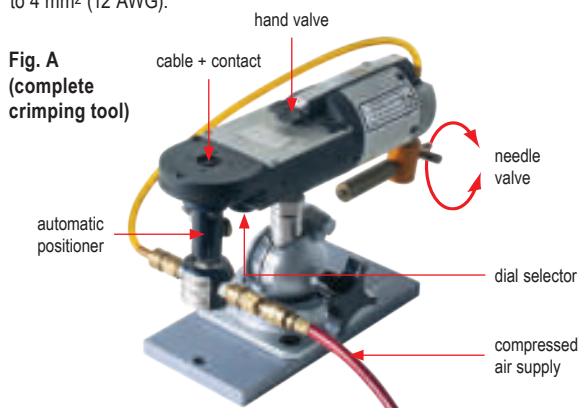
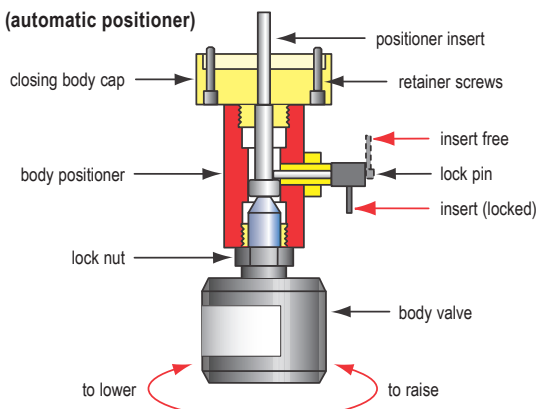


Fig. B (automatic positioner)



2. Installation or replacement of a positioner insert

- 1 Disconnect the workshop compressed air source.
- 2 Disconnect the air hoses from the automatic positioner (rapid connectors).
- 3 Remove the connection screws, using the 9/64" (3,5 mm) Allen wrench (supplied with the kit), to separate the automatic positioner from the crimping tool.

The indenters will not reach the fully closed position and the contact will be internally blocked if the geared mechanism is operating correctly.

- 4 Unscrew the positioner closing housing.
- 5 Install or replace the proper positioner insert in the positioner housing, replacing the underlying spring.
- 6 Reverse the operations, as described from point 4 to point 1.

3. Crimping position adjustment (Fig. B)

- 1 Release the automatic positioner from the crimping tool body (see points 1 and 2 "Installation or replacement of a positioner insert").
- 2 While holding the body positioner in position using a 19 mm wrench, loosen the lock nut with a 14 mm wrench.
- 3 Push the positioner insert toward the bottom and lock it using the lock pin. The indenters will not reach the fully closed position and the contact will be internally blocked if the geared mechanism is operating correctly.
- 4 If the pin doesn't lock, unscrew the body valve toward the bottom.
- 5 With the pin locked, tighten the body valve toward the top until it strikes against the positioner insert.
- 6 While maintaining that position, tighten the lock nut.
- 7 Replace and connect the positioner on the crimping tool.
- 8 Release the lock pin in the "free" position.

4. Checking the crimping complete cycle control mechanism

Correct operation can be checked based on the following procedure:

- 1 Reduce the pressure to 1 bar.
- 2 Using a contact that corresponds to the installed positioner, with size 0,5 and a wire with section 0,5 mm², use the crimping tool, referring to the crimping instructions. The indenters will not reach the fully closed position and the contact will be internally blocked if the geared mechanism is operating correctly.
- 3 To release the partially crimped contact, increase the air pressure of the line to 5,5 - 8,3 bar and again use the crimping tool. It will then complete the crimping, allowing the indenters to return to the fully open position. The indenters will not reach the fully closed position and the contact will be internally blocked if the geared mechanism is operating correctly.

5. Crimping instructions

- 1 To obtain the suitable selector number, refer to the data plate located on the cover of the positioner insert case, and adjust the dial selector as specified.
- 2 Insert the contact and the prepared conductor through the opening of the indenter in the crimping tool casing (Fig. A).
- 3 Exert slight pressure until the crimping tool automatically crimps the contact. **CAUTION: Wire sections less than 0,34 mm² (24 AWG) up to 0,08 mm² (28 AWG) or equivalent are not sufficiently rigid, so that it may be rather difficult to push the contact + wire.**
- 4 Check the position of the crimping on the contact crimping foot. Ideally, the crimping should be between the inspection hole and the top edge of the crimping foot. The head of the contact should not be squared and the inspection hole should be intact.

6. Instructions to check calibration

The operations to check the crimping tool must be carried out with the dial selector in position 4 and the CCPNP gauge.

ATTENTION! Do not crimp the gauge.

6.1 Calibration check

- 1 Disconnect the compressed air.
- 2 Push the positioner insert toward the bottom and lock it using the lock pin.
- 3 Reconnect the compressed air.
- 4 Turn the needle valve counter-clockwise to open the air supply (Fig. A).
- 5 The indenters will extend and remain in the extracted position until the valve is closed.
- 6 Check using the gauge, referring to the "go / no go" instructions reported below.
- 7 When the calibration check has been completed, close the needle valve turning it clockwise (Fig. A).
- 8 Put the lock pin in the "free" position.
 - "GO" - Insert the end (green) of the gauge as shown (Fig. 1). The gauge must pass freely between the indenter tips.
 - "NO GO" - Insert the end (red) of the gauge as shown (Fig. 2). The gauge should not pass through the opening.

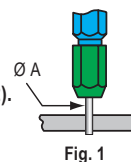


Fig. 1

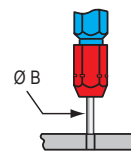


Fig. 2

"Go / no go" control gauge information

Gauge	Tool selector pos. No	Ø A ± 0,00254 (GO) green	Ø B ± 0,00254 (NO GO) red
CCPNP	4	0,991 (mm) 0,0390 (in)	1,118 (mm) 0,0440 (in)

7. Crimping tool maintenance

No maintenance is required. However, it is good practice to keep the indenter tips free from residual deposits of the coloured band (some types of crimp contacts as per MIL standards are identified by coloured bands in the crimping area) and any other debris. A metal brush may be used for this purpose. The following is strongly recommended:



1. DO NOT immerse the tools in a solution to clean them.
 2. DO NOT brush oil in the tools to lubricate them.
 3. DO NOT try to disassemble the tool or repair it.
- This is a high-precision crimping tool and must be used as such.

CCPZ RN

for 40 A / 16 A / 10 A crimp contacts

MIL profile



Item	Description	Part No.
	Manual crimping tool for 40/16/10 A contacts RENNSTEIG model (turret included) With incorporated positioner	CCPZ RN
	"Go/no go" control gauge, to verify indenter closure	CCPNP RN
	To be used to periodically check that the crimping tool meets standard requirements.	

Contacts		Pages
CX / RX HNM	40 A	F.10
CC / RC HNM	16 A	F.11-13
CD / RD HNM	10 A	F.14-16



Tutorial

CCPZ RN

use and maintenance instructions

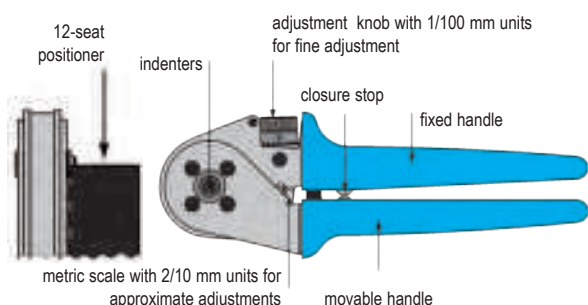
1. General specifications

The **CCPZ RN crimping tool** crimps with 8 pressure points, obtaining similar results to the prescriptions of standard MIL-C-22520/1. The tool has a geared mechanism for controlling the complete crimping cycle, and houses a positioning turret with 12 positions, six of which can be used for positioning the ILME male and female crimping contacts of series CD (10A max), CC (16A max) and CX (40 A max).

1.1 Crimping range

Conductor cross-sectional area range: from 0,14 mm² (26 AWG) to 10 mm² (8 AWG).

Caution! The handle of the tool must be in the open position when the turret is installed, disassembled or opened. If not, the turret and the crimping tool may be damaged.



2. Description of tool

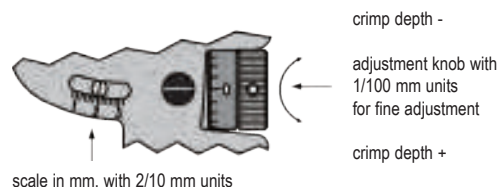
Crimping tool components: a first mobile handle, with a precision stop mechanism with teeth and an opening limiting guide; a second fixed handle with metric scale (units of 2/10 mm); an adjustment system with fine step adjustments of 1/100 mm; four indenters; a 12-seat positioner, fully rotating through 360° for accurate positioning of contacts. A reference table engraved on the tool surface provides the positioner (POS) number and crimping depth (SET) to select according to the type and size of the ILME contact (the crimping tool can be set to any crimping depth which may be required by the contact manufacturer).

3. Adjustment of crimp depth

Crimp depth to be adjusted as follows: the adjustment knob should be turned clockwise to reduce crimping depth, and anti-clockwise to increase it.

3.1 Adjustment tolerances:

- 1 scale mark on the knob = adjustment of 1/100 mm (0,01 mm);
- 1 complete rotation of knob = adjustment of 2/10 mm (0,2 mm, this indication can be read on the knob and on the approximate scale);
- 5 knob rotations = adjustment of 1,0 mm (this indication can be read on the scale).



4. Crimping instructions

The reference matrix on the crimping tool indicates the correct seat of the positioner (POS M1, F2, M3, F4, M5, F6) to select, and the crimping depth (SET) to adjust for the contact to be crimped.

The contact is inserted through the crimper entry hole on the opposite side of the positioner.

The contact is closed by closing the handles in the first stop position, in order to prevent the contact coming out off the crimper and to facilitate fitting the conductor in the contact.

The precision stop mechanism with teeth ensures consistently precise crimps, by forcing the crimper to close completely and finish the crimping cycle before the crimper can be re-opened.

Tool adjustment

Positioner seat = M1 (male) - F2 (female)

M1 - CDM../RDM..	F2 - CDF../RDF..	Section (mm ²)	Crimp depth (mm)
0,3	0,3	0,14-0,37	1,3
0,5	0,5	0,5	1,55
0,7	0,7	0,75	1,55
1,0	1,0	1,0	1,55
1,5	1,5	1,5	1,55
2,5	2,5	2,5	1,55

Positioner seat = M3 (male) - F4 (female)

M3 - CCM../RCM..	F4 - CCF../RCF..	Section (mm ²)	Crimp depth (mm)
0,3	0,3	0,14	1,2
0,3	0,3	0,25-0,37	1,3
0,5	0,5	0,5	1,55
0,7	0,7	0,75	1,55
1,0	1,0	1,0	1,55
1,5	1,5	1,5	1,8
2,5	2,5	2,5	1,8
3,0	3,0	3,0	1,9
4,0	4,0	4,0	2,0

Positioner seat = M5 (male) - F6 (female)

M5 - CXM../RXM..	F6 - CXF../RXF..	Section (mm ²)	Crimp depth (mm)
1,5	1,5	1,5	1,55
2,5	2,5	2,5	1,8
4,0	4,0	4,0	2,0
6,0	6,0	6,0	2,5
10,0	10,0	10,0	2,3

5. Calibration check

The crimping tool is adjusted in the manufacturer's plant. To ensure correct calibration, we advise you to check the tool with a gauge every working day.

This is easily done with the CCPNP RN cylindrical gauge in the 2,0 mm Ø position.

ATTENTION! Do not crimp the gauge.

Crimp depth of 2 mm can be adjusted with the adjustment knob (scale marked on "2", screw indicator on "0" as shown in the above figure).

Put the crimping tool in the completely position.

"GO" - Insert the end of the gauge as shown (Fig. 1).

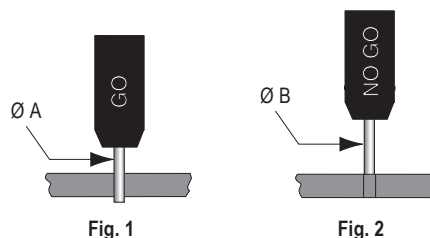
The gauge must pass freely between the indenter tips.

"NO GO" - Insert the end of the gauge as shown (Fig. 2).

The gauge should not pass through the opening.

"Go / no go" control gauge information

Gauge	Tool selector pos. No	Ø A (GO)	Ø B (NO GO)
CCPNP RN	2	1,94 (mm)	2,06 (mm)



6. Maintenance and repair

Keep the crimping tool clean and store it correctly when not in use.

The joints need to be lubricated periodically, and the pin stop circular clips must always stay in position.


This is a high precision crimping tool and must be used as such.

CCPZE RN

for 40 A / 16 A / 10 A crimp contacts

MIL profile



Item	Description	Part No.
	Battery operated hydraulic crimping tool for 40/16/10 A contacts (standard and HNM versions series CD/RD, CC/RC and CX/RX) RENNSTEIG HC-20 model. for EU for UK for AUS for US/CAN Digital indenter w/ incorporated positioner and locator, battery charger, bench mount and case included	CCPZE RN EU CCPZE RN UK CCPZE RN AU CCPZE RN US
	"Go/no go" control gauge, to verify indenter closure	CCPNP RN
	RENNSTEIG 4/8-indent crimping head 8.75 "ILME" (without device or locator)	CCPZE RN
	Li-Ion battery 12 V _{DC} / 1.5 Ah Li-Ion battery 12V _{DC} / 3.0 Ah	CCPZEB1.5 RN CCPZEB3.0 RN

Tool technical informations:

- Crimping force: 19 kN
- Size (L x H x W): 285 x 70 x 96 mm (310 x 70 x 96 mm with 3,0 Ah battery)
- Weight: 1,63 kg (with 1,5 Ah battery)
- Operating temperature: -10 to +50 °C
- Protection degree: IP20

Indenter technical informations:

- For crimping turned contacts according to MIL/SAE AS22520
- Indent settings in 0,01 mm increments, with digital setting and readout
- Setting functions in mm and inch
- Electronic wear monitoring

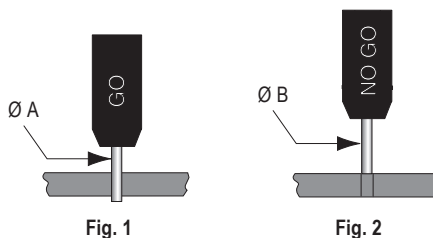
Rechargeable battery informations:

- Li-Ion battery 12 V_{DC} / 1.5 Ah (optional 3,0 Ah)
- Battery charger input: 220-240 V / 50-60 Hz (EU, UK, AU)
- Battery charger input: 115 V / 60 Hz (US)



"Go / no go" control gauge information

Gauge	Tool selector pos. No	Ø A (GO) (mm)	Ø B (NO GO) (mm)
CCPNP RN	2	1,94	2,06



Digital indenter with incorporated positioner



The reference matrix on the crimping tool indicates the correct seat of the positioner (POS M1, F2, M3, F4, M5, F6) to select, and the crimping depth (SET) to adjust for the contact to be crimped.

Positioner seat = M1 (male) - F2 (female)

CDM.. / RDM2D (male) CDF.. / RDF2D (female)	Section (mm ²)	Crimping depth (mm)
0,3	0,14-0,37	1,3
0,5	0,5	1,55
0,7	0,75	1,55
1,0	1,0	1,55
1,5	1,5	1,55
2,5	2,5	1,55

Positioner seat = M3 (male) - F4 (female)

CCM.. / RCM2D (male) CCF.. / RCF2D (female)	Section (mm ²)	Crimping depth (mm)
0,3	0,14 0,25-0,37	1,2 1,3
0,5	0,5	1,45
0,7	0,75	1,45
1,0	1,0	1,45
1,5	1,5	1,7
2,5	2,5	1,7
3,0	3,0	1,75
4,0	4,0	1,78

Positioner seat = M5 (male) - F6 (female)

CXM.. / RXM2D (male) CXF.. / RXF2D (female)	Section (mm ²)	Crimping depth (mm)
1,5	1,5	1,55
2,5	2,5	1,8
4,0	4,0	2,0
6,0	6,0	2,35
10,0	10,0	2,3


Contacts		Pages
CX / RX HNM	40 A	F.10
CC / RC HNM	16 A	F.11-13
CD / RD HNM	10 A	F.14-16

CCPZP RN

for 40 A/16 A/10 A crimp contacts

MIL profile



Item	Description	Part No.
	Pneumatic crimping tool for 40/16/10 A contacts (standard and HNM versions series CD/RD, CC/RC and CX/RX) RENNSTEIG CM 25-3 model. Digital indenter w/ incorporated positioner, locator and pedal footswitch included	CCPZP RN
	"Go/no go" control gauge, to verify indenter closure	CCPNP RN

Tool technical informations:

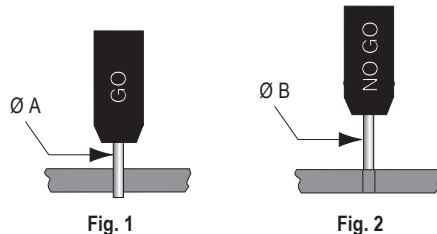
- Crimping force: 25 kN
- Operating pressure: 6 bar
- Air requirement: 0,75 l per working stroke
- Size (L x H x W): 325 x 500 x 280
- Weight: 30,5 kg

Indenter technical informations:

- For crimping turned contacts according to MIL/SAE AS22520
- Indent settings in 0,01 mm increments, with digital setting and readout
- Setting functions in mm and inch.
- Electronic wear monitoring with warning function

"Go / no go" control gauge information

Gauge	Tool selector pos. No	Ø A (GO) (mm)	Ø B (NO GO) (mm)
CCPNP RN	2	1,94	2,06



Digital indenter with incorporated positioner



The reference matrix on the crimping tool indicates the correct seat of the positioner (POS M1, F2, M3, F4, M5, F6) to select, and the crimping depth (SET) to adjust for the contact to be crimped.

Positioner seat = M1 (male) - F2 (female)

CDM.. / RDM2D (male) CDF.. / RDF2D (female)	Section (mm ²)	Crimping depth (mm)
0,3	0,14-0,37	1,3
0,5	0,5	1,55
0,7	0,75	1,55
1,0	1,0	1,55
1,5	1,5	1,55
2,5	2,5	1,55

Positioner seat = M3 (male) - F4 (female)

CCM.. / RCM2D (male) CCF.. / RCF2D (female)	Section (mm ²)	Crimping depth (mm)
0,3	0,14	1,2
	0,25-0,37	1,3
0,5	0,5	1,55
0,7	0,75	1,55
1,0	1,0	1,55
1,5	1,5	1,8
2,5	2,5	1,8
3,0	3,0	1,9
4,0	4,0	2,0


Positioner seat = M5 (male) - F6 (female)



CXM.. / RXM2D (male) CXF.. / RXF2D (female)	Section (mm ²)	Crimping depth (mm)
1,5	1,5	1,55
2,5	2,5	1,8
4,0	4,0	2,0
6,0	6,0	2,5
10,0	10,0	2,3

Contacts		Pages
CX / RX HNM	40 A	F.10
CC / RC HNM	16 A	F.11-13
CD / RD HNM	10 A	F.14-16

CIPZ D

for 5 A crimp contacts

MIL profile 

Item	Description	Part No.
	Manual crimping tool for CI/RI contacts DANIELS AFM8 model (positioner excluded)	CIPZ D
	Positioner (DANIELS K1450I) for CI/RI contacts (CI..A - CI..D - CI..2D CI..JD - RI..D series)	CITP D
	"Go/no go" control gauge, to verify indenter closure	CCPNP
	To be used to periodically check that the crimping tool meets standard requirements.	

TOOLS

F

Contacts	Pages
CI / RI HNM	5 A F.17



Tutorial

CIPZ D

use and maintenance instructions

1. General specifications

The **CIPZ D crimping tool** (Daniels designation AFM8) conforms to the U.S. Military Standard **MIL-C-22520/2C** (designation M22520/2-01)*. Crimping is performed with 8 pressure points and the tool is equipped with a geared mechanism to control the complete crimping cycle.

The tool must be equipped with an interchangeable positioner (CITP D) according to the series of contacts to be crimped.

* Since October 2011 the MIL-C-22520 series is being progressively replaced by a corresponding **SAE 1) AS22520** series. The military series will be fully cancelled once all SAE parts will be published. SAE International, so named since 2006 and established in 1905 as the *Society of Automotive Engineers*, is a U.S.-based, globally active professional association and standards developing organization working in various industries, having as core business the transport industries such as automotive, aerospace, and commercial vehicles.

2. Crimping range

Conductor cross-sectional area range: from 0,08 mm² (28 AWG) to 0,52 mm² (20 AWG).

Caution! The handle of the tool must be in the open position when the positioner is installed, disassembled or opened. If not, the positioner and the crimping tool may be damaged.

3. CITP D positioner installation

- 1 The crimping tool must be in the open position.
- 2 Remove the safety clip from the positioner guide.
- 3 Insert the previously selected **CITP D** positioner into the positioner guide on the head of the tool. Push down and rotate 90 degrees until bayonet pins lock.
- 4 Refer to the data plate on the **CITP D** positioner for the setup of the selector number that determines crimp height, based on the contact size and conductor size.
- 5 With the tool in open position, remove the spring clip then raise and rotate selector knob until number indicated on data plate for conductor size to be crimped is in line with SEL. NO. arrow. Reinstall spring clip to avoid unintended change of setup.

4. Crimping instructions

- 1 Insert the contact and the prepared (correctly stripped) conductor through the indenter opening in the positioner.
- 2 Squeeze the crimping tool handles together until ratchet releases. Handles will return to open position.
- 3 Check the position of the crimping on the contact crimp barrel. Ideally, the crimping should be between the inspection hole and the top edge of the crimp barrel.
The edge of the contact barrel should not result squared and the inspection hole should remain intact.

5. Removing the CITP D positioner

With the crimping tool in the open position, to disassemble the positioner, push down on the positioner to release the bayonet pins from the positioner guide. Turn 90 degrees anticlockwise and remove the positioner from the tool.

6. Instructions to check calibration

The operations to check the crimping tool must be carried out with the dial selector in position 8 and the CCPNP gauge.

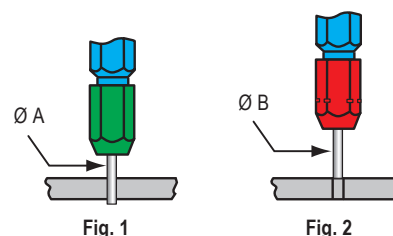
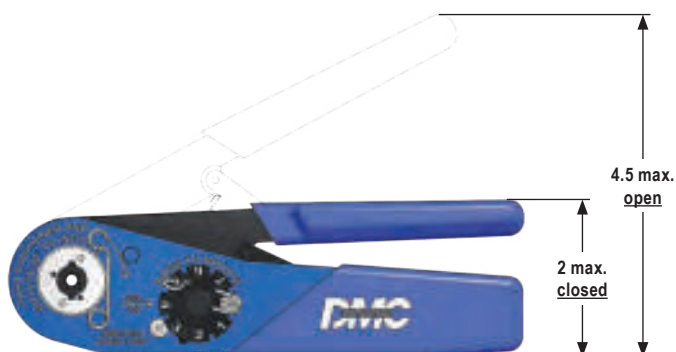
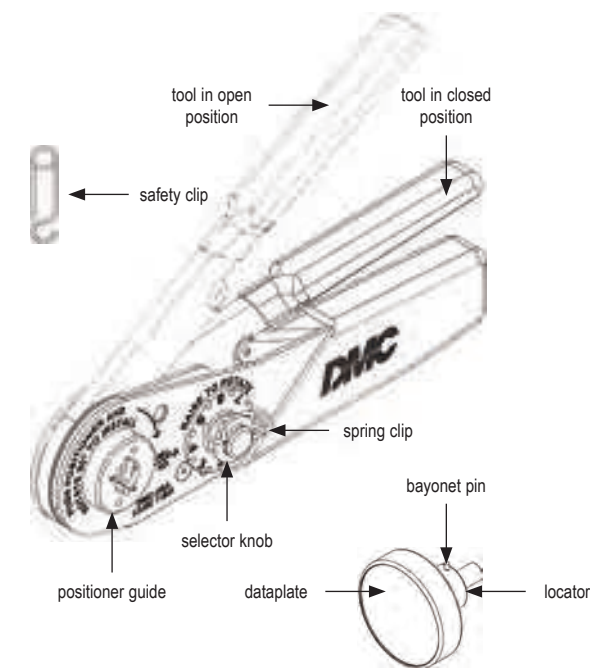
ATTENTION! Do not crimp the gauge.

6.1 Calibration check

- Put the crimping tool in the completely closed position.
- “GO” - Insert the end (green) of the gauge as shown (Fig. 1). The gauge must pass freely between the indenter tips.
 - “NO GO” - Insert the end (red) of the gauge as shown (Fig. 2). The gauge should not pass through the opening.

“Go / no go” control gauge information

Gauge	Tool selector pos. No	Ø A ± 0,00254 (GO) green	Ø B ± 0,00254 (NO GO) red
CCPNP	4	0,991 (mm) 0,0390 (in)	1,118 (mm) 0,0440 (in)



7. Crimping tool maintenance

No maintenance is required. However, it is good practice to keep the indenter tips free from residual deposits of the coloured band (some types of crimp contacts as per SAE (MIL) standards are identified by coloured bands in the crimping area) and any other debris. A small wire brush may be used for this purpose.

- The following is strongly recommended:
- 1 DO NOT immerse the tools in a solution to clean them.
 - 2 DO NOT brush oil in the tools to lubricate them.
 - 3 DO NOT try to disassemble the tool or repair it.






This is a high-precision manual crimping tool and must be used as such.

CIPZP D

for 5 A crimp contacts

MIL profile



Item	Description	Part No.
	Pneumatic crimping tool for CI/RI contacts DANIELS WA22 model equivalent to CIPZ D (turret excluded)	CIPZP D
	Positioner (DANIELS K1450I) for CI/RI contacts (CI..A - CI..D - CI..2D CI..JD - RI..D series) Conforms to international standard MIL-C-22520/1. It precisely positions the contact where crimping is performed.	CITP D
	"Go/no go" control gauge to verify indenter closure Conforms to international standard MIL-C-22520/3. To be used to periodically check that the crimping tool meets standard requirements.	CCPNP
	Bench support for CCPZP D pneumatic crimping tool (DANIELS BM-2A)	CCSPZP
	Pneumatic foot valve (DANIELS WA10A)	CCVPP

"Go / no go" control gauge information

Gauge	Tool select pos. No.	Ø A ± 0,00254 mm (GO) green	Ø B ± 0,00254 mm (NO GO) red
CCPNP	8	0,991 (mm) 0,0390 (in)	1,118 (mm) 0,0440 (in)

Contacts	Pages
CI / RI HNM	5 A F.17





CXPZ TP – CCPZ TP

for 40 A/16 A/10 A crimp contacts

Square profile



Item	Description	Part No.
	<p>Manual crimping tool for 40 A contacts RENNSTEIG model (crimping dies and turret head are included)</p> <p>CXPZ TP is a simple but effective "square shaping" manual crimping tool incorporating discrete (3-size nests) crimping dies and turret positioner for relevant crimp contacts sizes ranging from 1.5 to 6.0. Size 10 requires CCPZ RN (Rennsteig PEW 8.75) or CXPZP D (Daniels WA27-309-EP)</p> <p>For series CX/RX (40 A) contacts, manual crimping tool CXPZ D (up to size 6.0) and CCPZ RN (for all sizes) or the pneumatic CXPZP D for large volumes of crimps, are recommended for highly demanding applications, such as in transportation.</p>	<p>CXPZ TP</p>
	<p>Manual crimping tool for 16 A and 10 A contacts RENNSTEIG model (crimping dies and turret head are included)</p> <p>CCPZ TP is a simple but effective "square shaping" manual crimping tool incorporating discrete (4-size nests) crimping dies and dedicated turret positioner for relevant crimp contacts series and sizes.</p> <p>For series CD/RD (10 A) and CC/RC (16 A) contacts, manual crimping tool CCPZ MIL, their equivalent pneumatic CCPZP and CCPZPA for large volumes of crimps, or even the fully automatic stripper crimper machine ZFU, as well as the universal crimping tool CCPZ RN, are recommended for highly demanding applications, such as in transportation.</p>	<p>CCPZ TP</p>


Contacts		Pages
CX / RX HNM	40 A	F.10
CC / RC HNM	16 A	F.11-13
CD / RD HNM	10 A	F.14-16

SDPZ TP

for 10 A crimp contacts

Stamped contacts



Item	Description	Part No.
	Manual crimping tool for 10 A SD contacts (for loose pcs) RENNSTEIG PEW12 model (crimping dies and turret head are included)	SDPZ TP



Contacts		Pages
SD	10 A	F.18

SIPZ W – SIPZC W

for 5 A crimp contacts

Stamped contacts



Item	Description	Part No.
	Manual crimping tool for 5 A SI contacts (for loose pcs.) WEZAG CS 10-D model	SIPZ W
	Manual crimping tool for 5 A SI contacts (for coils) WEZAG CS 20 KTVR-D model	SIPZC W

Application range


Cross section range (mm ² / AWG)	Crimp height ± 0,05	Crimp width ± 0,05	Contact type
0,08-0,2 / 28-24	0,70	1,15	SI stamped
0,2-0,52 / 24-20	0,75	1,45	

Contacts	Pages
SI	F.19

ZFU-CD

for 16 A / 10 A crimp contacts

Crimping machine

Item	Description	Part No.
	Automatic stripping and crimping machine Zoller+Fröhlich AM-03 Universal model	ZFU-CD

- Technical informations:**
- Drive: electro-pneumatic
 - Electric feeder: 230 V / 50 Hz
 - Absorbed power: 120 VA
 - Fuse: 2 x 2 A mT
 - Air operating pressure: 5.5 bar
 - Air consumption: 2 nl/cycle
 - Conductors conformity: IEC 60228 class 5
 - Rated section: 0,34-2,5 mm² (AWG 22-14)
 - Feeding length: 52 mm
 - Contacts: loose, turned
 - Contact breaker: see list of tools
 - Feeding: vibrating conveyor
 - Crimping form: 4/8 ratchets
 - Cycle time: 2,5 s - 3 s
 - Continuous sound level: < 70 dB (A)
 - Size (L x H x W): 530 x 480 x 500 mm
 - Weight: 40 kg
 - Colour: RAL 5012

Tool list

Contacts	CD, RD.. (10 A max)						CC, RC.. (16 A max)				
	0,34	0,5	0,75	1,0	1,5	2,5	0,5	0,75	1,0	1,5	2,5
Conductor section (mm ²)	0,34	0,5	0,75	1,0	1,5	2,5	0,5	0,75	1,0	1,5	2,5
AWG (approximate)	22	20	18	18	16	14	20	18	18	16	14
Feeding bowl/male	A						B (M)				
Feeding bowl/female	-						B (F)				
Feeding tube	A						B				
Wire holder	0,34	0,5-1,5			2,5		0,5-1,5			2,5	
Starting unit	AB						AB				
Stripping blades	V-shaped blades						V-shaped blades				
Rear blade spacers left/right	0,5 / 1,0 mm						0,5 / 1,0 mm				
Contact holder - pins	A (M)						B				
Contact holder - bushes	A (F)						B				
Contact stop	A						B				

Preset stripping and contact crimping programs

Contacts	CD, RD.. (10 A max)						CC, RC.. (16 A max)				
	0,34	0,5	0,75	1,0	1,5	2,5	0,5	0,75	1,0	1,5	2,5
Conductor section (mm ²)	0,34	0,5	0,75	1,0	1,5	2,5	0,5	0,75	1,0	1,5	2,5
AWG (approximate)	22	20	18	18	16	14	20	18	18	16	14
Program number	1A	2A	3A	4A	5A	6A	7B	8B	9B	10B	11B
Stripping position (mm)	0,75	1,00	1,20	1,30	1,40	1,70	1,00	1,20	1,30	1,40	1,70
Crimping position	1,30	1,35	1,40	1,50	1,55	1,60	1,40	1,40	1,50	1,55	1,70

Contacts		Pages
CC / RC HNM	16 A	F.11-13
CD / RD HNM	10 A	F.14-16

Supplied with the following accessories:

- 1x vibrating conveyor feeder bowl for CD, RD contact series;
- 1x vibrating conveyor feeder bowl for male CC, RC contact series;
- 1x vibrating conveyor feeder bowl for female CC, RC contact series;
- 1x feeder tube (contact passage from vibrating conveyor to machine) for CD, RD contact series;
- 1x feeder tube (contact passage from vibrating conveyor to machine) for CC, RC contact series;
- 1x contact holder (in crimping position) for male CD, RD contact series;
- 1x contact holder (in crimping position) for female CD, RD contact series;
- 1x contact holder (in crimping position) for CC, RC contact series;
- 1x contact stop for CD, RD contact series;
- 1x contact stop for CC, RC contact series;
- 1x wire holder for 0,34 mm² cables;
- 1x wire holder for 0,5 to 1,5 mm² cables;
- 1x wire holder for 2,5 mm² cables;
- 1x "GO / NO GO" control gauge;
- 1x Allen wrench for setup operations;
- 1x set of spacers to regulate the stripping length;
- 1x removal tool to extract contacts from the crimping chamber.

General specifications

The **Zoller+Fröhlich AM-03** Universal stripping-crimping machine is a semi-automatic, electro-pneumatically operated bench machine used to quickly and reliably strip flexible copper wires and to crimp loose, turned crimp male and female, **CD, RD HNM** series (10 A max) and **CC, RC HNM** series (16 A max) contacts in a single run.

The contacts are automatically fed by means of a vibro-conveyor unit fitted on the top section of the machine.

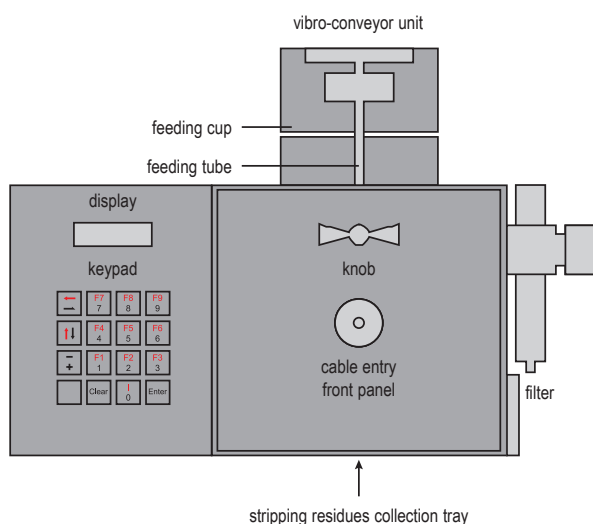
The machine carries out the crimping operation with four, eight pressure point indenters, in compliance with the requirements set out in the MIL-C-22520/1 standard.

The stripping depth and crimping depth adjustment is controlled by a software controlled motor. Up to 50 different combinations may be stored and retrieved from the program; these combinations are useful, for example, to meet different requirements related to the wire insulator type and thickness.

The adjustment and programming operations are carried out by using the keypad located on the front panel. The LCD display shows all the functions, the main information and any errors.

The machine is fitted with devices used to check that the crimping cycle has been completed.

The general safety instructions described in the machine user and maintenance manual must be followed and the use of the machine should only be restricted to qualified and trained personnel.



Crimping range

Wire section: from 0,34 mm² (AWG 26) to 2,5 mm² (AWG 14).

Description of the machine

To ensure a correct operation, the machine must be positioned on a hard bench, which does not amplify the effects of the internal movements occurring inside the machine. The machine consists of a vibrator which loads the contacts, of a tube which feeds the contacts and of a motorised wire stripping and contact crimping unit.

For each type and size of contact, the machine is provided with a factory stored preset program (see the machine user manual), which may be customised at any time.

The program allows the user to:

load, edit and save a program, as well as check/edit the stripping length and depth and the crimping depth.

Warning: when the machine is switched on, the working program is always the last program used.

The machine electronics adjustment is carried out by means of the keypad. Select one of the 12 programs (see table on page F.50) according to the contact used*.

Each program stores the stripping and crimping depth.

The stripping depth is the measurement in mm of how much the stripping blades must penetrate the insulator to strip it off, and depends on the type of cable used.

The crimping depth is the measurement in mm of how much the four indenters must penetrate the contact at the end of the crimping operation.

This depth depends on the size and shape of the contact (crimp shaft thickness) and determines the quality of the crimping operation in terms of gas tightness and resistance to tensile stress.

* The machine also has a 12C program suitable for 10 A, 2,5 mm² crimp contacts with 6 mm stripping length.

This program is therefore unsuitable for ILME CD, RD HNM series contacts (stripping length 8 mm).

Operational setups

The tool carrier carriage may be accessed by opening the front door, by anticlockwise rotation of the knob, which releases the pressure from all the valves.

For tool selection, see table on page F.50.

- For CD, RD HNM series male and female crimp contacts (10 A max), the feeding cup A must be fitted onto the machine, whilst for CC, RC HNM series crimp contacts (16 A max) feeding cup B (M) for male contacts and B (F) for female contacts must be used.
- The feeding tubes to be fitted are A for CD, RD HNM series contacts and B for CC, RC HNM series contacts respectively.
- The wire holders which support the wire during the stripping stage feature three different sizes for CD, RD HNM contacts and two sizes for CC, RC HNM contacts.
- The contact holders are two (A (M) for male contacts and A (F) for female contacts) for CD, RD HNM series contacts, according to the different rear diameter between male and female contacts in this series, whilst there is only one holder (B) for CC, RC HNM series contacts.
- The contact holder is A for CD, RD HNM series contacts and B for CC, RC HNM series contacts.

Feeding the wire

The wire must be cut straight and the single braids must not be bent or pulled apart; in particular, the first 4 cm must be perfectly straight.

Checking the stripping depth:

The machine can be operated simply as a stripping machine by disabling the crimping operation. Please refer to the machine user manual.

Maintenance and repairs

Stripping residues collection tray: empty the tray approximately every 2000 cycles (the frequency depends on the sizes of the stripped wire and on the stripping length).

Pneumatically controlled maintenance unit: regularly drain any water that may have collected.

The trap may be cleaned with water.

To remove the trap, simply disconnect the air supply.

The filter unit may be unscrewed for cleaning purposes, then immersed in a cleaning agent (such as petrol or oil), thoroughly washed and dried.

Checking the calibration values

The correct calibration of the machine must be periodically checked by using the "GO / NO GO" caliper supplied as standard with the machine, by following the procedure described in the machine user and maintenance manual.

Crimping machine




Item	Description	Part No.				
	Automatic stripping and crimping machine for 10 A stamped contacts SD series (Reel version -R) Schäfer Werkzeug EPS 2001 model Complete of stripping unit, crimp monitor system and paper winder	SDPZP Z				
	Crimping applicator for 10 A SDFA / SDMA 1.0R 0,37-0,5 mm ² (AWG 26-22)	SDTP 0.5 S				
	Crimping applicator for 10 A SDFA / SDMA 1.0R 0,75-1,0 mm ² (AWG 18)	SDTP 1.0 S				
	Crimping applicator for 10 A SDFA / SDMA 2.5R 1,5-2,5 mm ² (AWG 16-14)	SDTP 2.5 S				
<table border="1"> <thead> <tr> <th>Contacts</th> <th>Pages</th> </tr> </thead> <tbody> <tr> <td>SD</td> <td>10 A F.18</td> </tr> </tbody> </table>		Contacts	Pages	SD	10 A F.18	Technical informations: <ul style="list-style-type: none"> - Dimensions (W x L x H): 520 x 480 x 730 mm - Closing height: 135,78 mm - Stroke: 40 mm - Weight: 100 kg - Drive: 0.75 kW three-phase motor - Motor speed: 440 – 2000 RPM - Pressing force: 20 kN - Power supply: 230 V, 50/60 Hz - Compressed air: 6 bar - Network: RJ-45
Contacts	Pages					
SD	10 A F.18					

all dimensions are considered without contact reel

SIPZP Z

for 5 A stamped crimp contacts

Crimping machine

Item	Description	Part No.
	<p>Automatic stripping and crimping machine for 5 A stamped contacts SI series (Reel version -R) Shäfer Werkzeug EPS 2002 model</p> <p>Complete of stripping unit, crimp monitor system and paper winder</p>	SIPZP Z
	<p>Crimping applicator for 5 A SIF / SIM 0.2R 0,08-0,21 mm² (AWG 28-24)</p>	SITP 0.2 S
	<p>Crimping applicator for 5 A SIF / SIM 0.5R 0,21-0,52 mm² (AWG 24-20)</p>	SITP 0.5 S




Contacts	Pages
SI	F.19

Technical informations:

- Dimensions (W x L x H): 520 x 480 x 730 mm
- Closing height: 135,78 mm
- Stroke: 40 mm
- Weight: 100 kg
- Drive: 0.75 kW three-phase motor
- Motor speed: 440 – 2000 RPM
- Pressing force: 20 kN
- Power supply: 230 V, 50/60 Hz
- Compressed air: 6 bar
- Network: RJ-45







all dimensions are considered without contact reel

CX7ES – CXES**for 70 A/40 A crimp contacts****Removal tools**

Item	Description	Part No.
	Removal tool for 80 A / 70 A contacts (CX7 series)	CX7ES
	Removal tool for 40 A contacts (CX/RX series) and cables Ø ≤ 5 mm	CXES
	Removal tool for 40 A contacts (CX/RX series) and cables Ø ≤ 7,5 mm	CXES-10

Contacts		Pages
CX7 / RX7 HNM	70 A	F.9
CX / RX HNM	40 A	F.10

CQES – CCES – CIVES**for 16 A/10 A/5 A crimp contacts****Removal tools**



Item	Description	Part No.
	Removal tool for 16 A contacts (CC and RC HNM series)	CQES
	Removal tool for 10 A contacts (CD and RD HNM series)	CCES
	Replacement tip for CCES removal tool	CCPR RN
	Removal tools for 5 A contacts, 0,2 - 0,5 mm ² (CI and RI HNM series)	CIVES
	Removal tools for 5 A contacts, 0,75 mm ² (CI and RI HNM series)	CIES B
	Insertion tool for insertion of crimped contacts up to 0,75 mm ²	CCINA

Contacts		Pages
CC / RC HNM	16 A	F.11-13
CD / RD HNM	10 A	F.14-16
CI / RI HNM	5 A	F.17

CHES – CH1ES

Removal tools

for CX 02..H contact holder



Item	Description	Part No.
	Contact holder removal tool for CX 02 4H and CX 02 H inserts	CHES
	Contact holder removal tool for CX 02 CH inserts	CH1ES

Inserts		Poles	Pages
CX 02 4H	40 A	2	C.52
CX 02 H	16 A	2	C.53
CX 02 CH	16 A	2	C.54

CMPEs – CMPEs B

for metal pneumatic contacts

Removal tools


Item	Description	Part No.
	Removal tool for metal pneumatic contacts Ø 3 - 4 and 6 mm	CMPEs
	Removal tool for metal pneumatic contacts Ø 8 and 10 mm	CMPEs B

Inserts	Poles	Pages
CX 03 MP	3	C.90
CX 3.0 MPA / MPQ / MP		C.91
CX 4.0 MPA / MPQ / MP		C.91
CX 6.0 MPA / MPQ / MP		C.91
CX 02 MPB	2	C.92
CX 8.0 MPQ / MP		C.93
CX 10 MPQ / MP		C.93

CLES

Removal tool

for POF/MOST® and coaxial contacts


Item	Description	Part No.
	Removal tool for the extraction of contacts from the CX L and CX R inserts	CLES

Inserts	Poles	Pages
CX 04 R	4	C.80
CX 04 L	4	C.81

CLCES

Removal tool

for LC fibre optic contacts


Item	Description	Part No.
	Removal tool for the extraction of LC fibre optic contacts or LC duplex patch cord from the CX 06 LC inserts	CLCES

Inserts	Poles	Pages
CX 06 LC	6	C.85

CX BES

Extraction tool

for MIXO BUS connectors


Item	Description	Part No.
	Extraction tool for shielded connectors	CX BES

Inserts		Poles	Pages
CX 1/2 BD	10 A	1/2 (aux.)	A.37
CX 02 B		1 + shield	C.62
CX 01 BC	16 A	1 + shield	C.63
CX 01 B	10 A	1 + shield	C.64
CX 04 B	10 A	4 + shield	C.64
CX 08 B	5 A	8 + shield	C.65

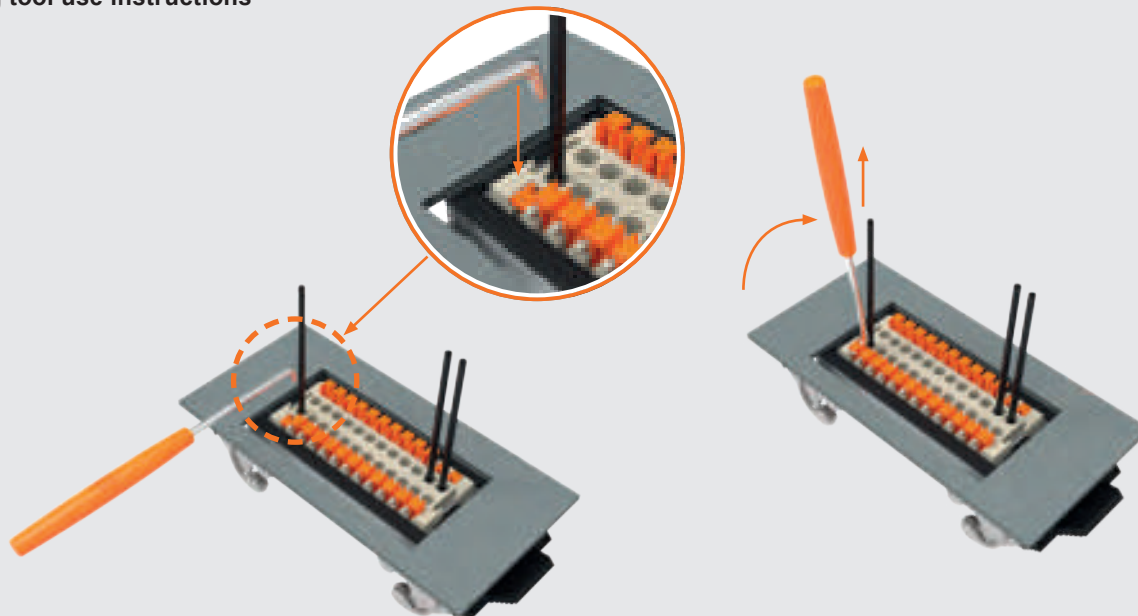
CSHES

Reopening tool

for SQUICH® inserts

Item	Description	Part No.
	<p>Reopening tool for SQUICH® actuator button</p> <p>It allows the release of the connection from a SQUICH® terminal without disassembly the insert from the bulkhead mounting housing, by operating from the accessible rear side of the control panel. With mains power disconnected, the smoothed hook-shaped tool tip is inserted in the slot of the actuator button head of the corresponding terminal, then by a delicate tilt towards the centre of the connector, the tools acts as a lifting lever for the actuator button, releasing the wire.</p> <p>Not suitable for SQUICH® terminals of CKSH inserts or MIXO CX 05 SH modular inserts.</p>	CSHES

Reopening tool use instructions



Inserts	Poles	Pages	
CSAH	10 A	10 to 32 + ⊕	B.24-26
CSH	16 A	6 to 48 + ⊕	B.52-57
JSH...S	16 A	6 to 48 + ⊕	B.58-63
CSHT	16 A	10 to 24 + ⊕	B.66-68
CDSH	10 A	9 to 84 + ⊕	B.102-107
CDSH 06 NC	10 A	6 + ⊕	B.108
CMSH	16 A	3/2 (aux.) to 20/4 (aux.) + ⊕	B.149-153
RSH	16 A	6 to 24 + ⊕	H.14-17
RDSH	10 A	9 to 42 + ⊕	H.26-29






Watch our clip

CCW CT

Punching tool

for bulkhead mounting housings

Item	Description	Part No.
	Hydraulic punching tool (without punching unit)	CCW CT
	Punching unit for M20 hole Punching unit for M25 hole Punching unit for M32 hole	CCW M20 CCW M25 CCW M32
	Punching units for panel cut-out of bulkhead mounting housings for size 21.21 CK/CKA for size 21.21 CK/CKA IA4 and AP/IAP25 for size 21.21 CGK IP68 for size 21.21 IVG for size 32.13 for MIXO ONE for MIXO TWO CXA 02 IA, MXA 02 AP/IAP for size 49.16 for size 66.16 for size 44.27 for size 57.27 for size 77.27 for size 104.27	CCW PD 03 CCW PD 03.4 CCW PD 03G CCW PD 03IVG CCW PD 08 CCW PD 1M CCW PD 2MIAP CCW PD 15 CCW PD 25 CCW PD 06 CCW PD 10 CCW PD 16 CCW PD 24

Tool information

Punching unit	Bulkhead mounting housing	Pilot hole	Mounting configuration		Draw stud	Adapter	Spacer
			Hydraulic tool operation CCW CT	Manual operation			
	Size	(mm)					
CCW M20	M20 hole or MKA IAF20 housings	Ø 10,0	without adapter and with spacer	–	CCW CT	CCW CT	CCW CT
CCW M25 dim. Ø 25 mm	M25 hole or MKA IAF25 housings	Ø 10,0	with adapter and with spacer	–	CCW CT	CCW CT	CCW CT
CCW M32	M32 hole for MKA IF	Ø 20,0	with adapter and with spacer	–	CCW CT	CCW CT	CCW CT
CCW PD 03	21.21	Ø 14,5	with adapter and with spacer	with screw ball-bearing nut (no adapter and no spacer)	CCW PD 03	CCW PD 03	CCW CT
CCW PD 03.4	21.21 (CK/CKA IA4 and IAP25)				CCW PD 03.4	CCW PD 03.4	CCW PD 03.4
CCW PD 03G	21.21 (CGK IP68)				CCW PD 03G	CCW PD 03G	CCW CT
CCW PD 03IVG	21.21 (IVG)	Ø 14,5	with adapter and with spacer	with screw ball-bearing nut (no adapter and no spacer)	CCW PD 03IVG	CCW PD 03IVG	CCW CT
CCW PD 08	32.13	Ø 14,5	with adapter and with spacer	with screw ball-bearing nut (no adapter and no spacer)	CCW PD 08	CCW PD 08	CCW PD 08
CCW PD 1M	MIXO ONE	Ø 14,5	without adapter and without spacer	with screw ball-bearing nut (no adapter and no spacer)	CCW PD 1M	CCW PD 1M	CCW CT
CCW PD 2MIAP	MIXO TWO (CXA 02 IA, MXA 02 AP/IAP)	Ø 20,4	without adapter and without spacer	–	CCW PD 2MIAP	CCW PD 2MIAP	CCW PD 2MIAP
CCW PD 15	49.16	Ø 20,4	without adapter and without spacer	–	CCW PD 15	not needed	not needed
CCW PD 25	66.16				CCW PD 25	not needed	not needed
CCW PD 06	44.27	Ø 25,4	without adapter and without spacer	–	CCW PD 06	not needed	not needed
CCW PD 10	57.27				CCW PD 10	not needed	not needed
CCW PD 16	77.27				CCW PD 16	not needed	not needed
CCW PD 24	104.27				CCW PD 24	not needed	not needed

CCW CT

use and maintenance instructions

Hydraulic operating instructions (CCW PD ..)

1. Screw the short thread of the 13,0/11,0 mm draw stud ③ into the 3/4" UNF adapter ⑦ (CCW PD 03/03G only).
2. Screw the 13,0/11,0 mm draw stud ③ complete with the 3/4" UNF adapter ⑦ onto the hydraulic cylinder or screw the short thread of any of the larger draw studs ③ (without the adapter) directly onto the hydraulic cylinder (CCW PD 03/03G only).
3. Put the die ④ onto the draw stud ③ and move it towards the hydraulic cylinder. If necessary, place the spacer ⑥ between the hydraulic cylinder and die ④.
4. Insert draw stud ③ with pre-mounted die through the pilot hole in the sheet until the die abuts the sheet.
5. Place the punch ② onto the draw stud and move it towards the sheet until it abuts the sheet.
6. Screw the counter nut ① onto the thread of the draw stud ③.
7. Adjust punch rectangularly (4 marks on die) and tighten counter nut manually.

Punching

8. Operate hydraulic punch CCW CT driver until punch is drawn through sheet.
9. Depressurise hydraulic punch driver after punching.
10. Remove the counter nut ① and punch ② from the draw stud ③.
11. Remove the die ④ from the draw stud ③ and remove slugs from the die ④.

Drilling mounting holes

When punching, the position of mounting holes are marked. Use suitable spiral drill to drill mounting holes.

Manual operating instructions (CCW PD 03/..03G/..03IVG/ and ..1M)

Knockout punch mounting

1. Screw the ball-bearing nut ⑤ onto the long thread of the draw stud 13,0/11,0 mm ③. Put the die ④ onto the draw stud ③ and move it towards the ball bearing nut ⑤.
2. For further steps refer to hydraulic operating instructions steps 4 to 7.

Punching

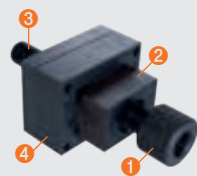
3. Use screw wrench SW 24 to rotate ball-bearing nut ⑤ until punch is drawn through sheet.
4. For further steps refer to hydraulic operating instructions steps 10 to 11.

Prior to commissioning please read operating instructions.

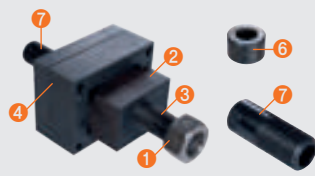
Components under voltage must not be machined.

Prior to operating ensure de-energised state of the work environment (e.g. switch cabinet) or the material to be machined.

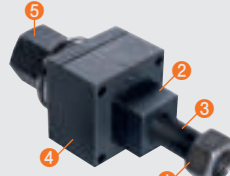
Hydraulic operating CCW PD.. (except CCW PD 03/ 03G)



Hydraulic operating (CCW PD 03G/..03IVG/..1M and CCW M32)



Manual operating (CCW PD 03/..03G/..03IVG/ and ..1M)



Legend:

- ① Counter nut
- ② Punch
- ③ Draw stud
- ④ Die
- ⑤ Ball-bearing nut
- ⑥ Spacer
- ⑦ Adapter

Tool information

Product number	Bulkhead mounting housing size	Accessories	Draw stud	Pilot hole	Sheet thickness	Manual screw-wrench use	Hydraulic use
	Size		Delivered with	Ø (mm)			
CCW M20	M20 hole or MKA IAF20 housings	Punch and die 20,5 M20	3/8"	10,0	St./Fe. 2 mm	●	●
CCW M25 *	M25 hole or MKA IAF25 housings	Punch and die 25,4 M25	3/8"	10,0	St./Fe. 2 mm		● **
CCW M32	M32 hole for MKA IF	Punch and die 32,5 M32	13,0/11,0 mm	20,0	St./Fe. 2 mm		●
		Panel cut-outs (mm) ****					
CCW PD 03	21.21	22,2 × 22,2	13,0/11,0 mm	14,5	St./Fe. 2 mm	●	● ***
CCW PD 03.4	21.21 (CK/CKA IA4 and IAP25)	25 × 25	13,0/11,0 mm	14,5	St./Fe. 2 mm	●	●
CCW PD 03G	21.21 (CGK IP68)	21,3 × 21,3	13,0/11,0 mm	14,5	St./Fe. 2 mm	●	● ***
CCW PD 03IVG	21.21 (IVG)	26 × 26	13,0/11,0 mm	14,5	St./Fe. 2 mm	●	● ***
CCW PD 08	32.13	38,5 × 40	13,0/11,0 mm	14,5	St./Fe. 2 mm	●	●
CCW PD 1M	MIXO ONE	32 × 27,5	13,0/11,0 mm	14,5	St./Fe. 2 mm	●	●
CCW PD 2MIAP	MIXO TWO (CXA 02 IA, MXA 02 AP/IAP)	23 × 27,1	13,0/11,0 mm	20,4	St./Fe. 2 mm		●
CCW PD 15	49.16	24 × 57	19,0/14,0 mm	20,4 M20	St./Fe. 3 mm		●
CCW PD 25	66.16	24 × 73	19,0/14,0 mm	20,4 M20	St./Fe. 3 mm		●
CCW PD 06	44.27	36 × 52	25,0/21,0 mm	25,4 M25	St./Fe. 3 mm		●
CCW PD 10	57.27	36 × 65	25,0/21,0 mm	25,4 M25	St./Fe. 3 mm		●
CCW PD 16	77.27	36 × 86	25,0/21,0 mm	25,4 M25	St./Fe. 3 mm		●
CCW PD 24	104.27	36 × 112	25,0/21,0 mm	25,4 M25	St./Fe. 3 mm		●

* CCW M25 can be used to drill M25 hole.

** Adapter M25 and spacer (delivered with CCW CT) needed.



*** Adapter (delivered with CCW PD 03/03G/IVG) and spacer (delivered with CCW CT) needed.

**** Relevant Panel cut-outs can be found at the end of each enclosure series pages.

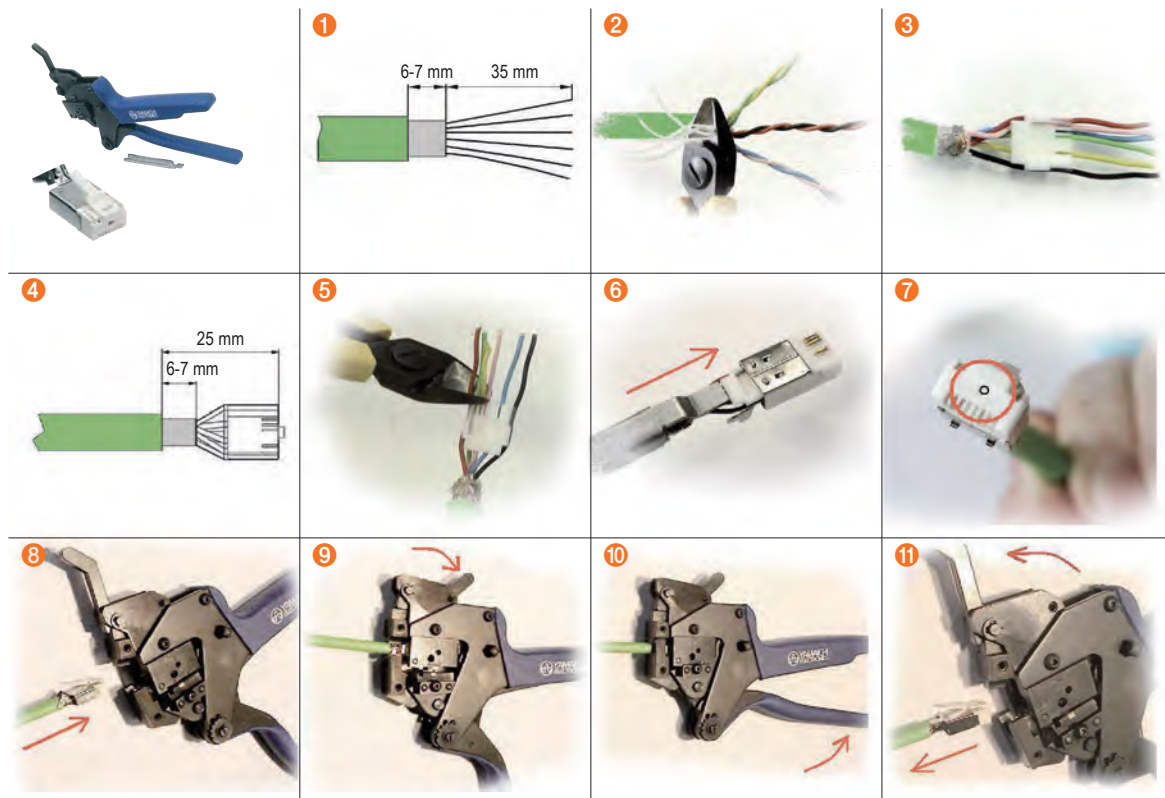
CJPZ Y – CJST

Data connectors tools

for RJ45 Cat. 5

Item	Description	Part No.
	RJ45 CJ series plug insert crimp pliers basic tool YAMAICHI Y-ConTool-11 mod. with plug insert inserter	CJPZ Y
	Y-ConTool-20 shielded cable stripper cuts the cable sheath and releases the wires in a single operations	CJST

RJ45 plug insert crimp pliers mounting instructions



The diagram illustrates the 11 steps for mounting an RJ45 plug insert using crimp pliers:



- Strip the outer sheath of the cable by 35 mm, leaving 6-7 mm of the shield exposed.
- Strip the individual conductors to the required length.
- Twist the conductors together.
- Strip the shield to 25 mm, leaving 6-7 mm of the shield exposed.
- Strip the conductors to the required length.
- Strip the shield to the required length.
- Strip the conductors to the required length.
- Strip the shield to the required length.
- Strip the conductors to the required length.
- Strip the shield to the required length.
- Strip the conductors to the required length.
- Strip the shield to the required length.

Inserts	Pages
CX JM	A.30, C.74-75

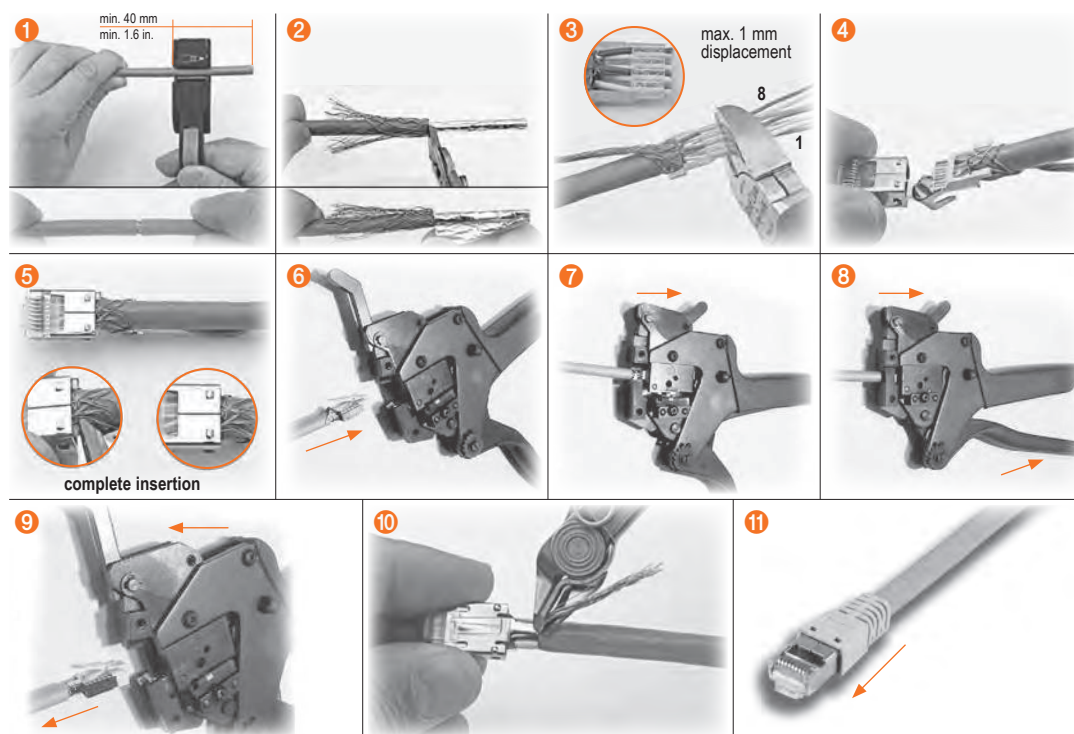
CJPZ T – CJST

Data connectors tools

for RJ45 Cat. 6A

Item	Description	Part No.
	RJ45 CJ series plug insert manual crimp pliers	CJPZ T
	Y-ConTool-20 shielded cable stripper cuts the cable sheath and releases the wires in a single operations	CJST

RJ45 plug insert crimp pliers mounting instructions




Inserts	Pages
CX 8 J6M	A.31, C.70

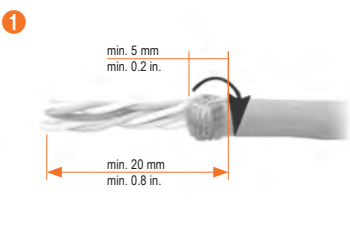
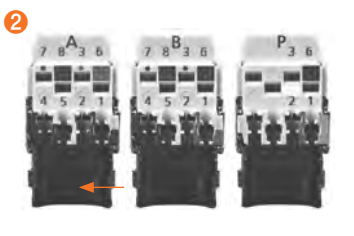
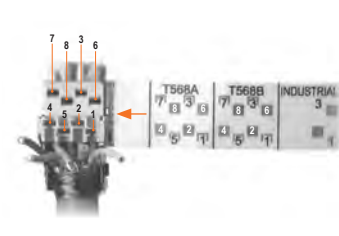
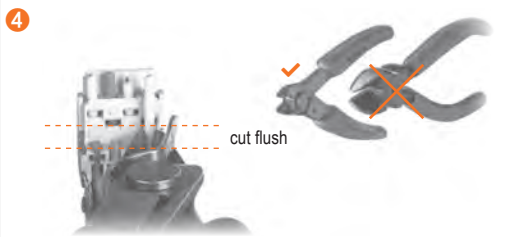
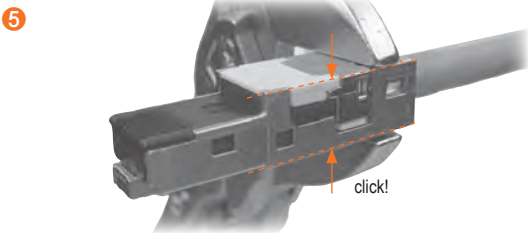

CJPW K

Data connectors tool

for CX 8 J6IM insert

Item	Description	Part No.
	Manual IDC wrench pliers for CX 8 J6IM insert	CJPW K

CX 8 J6IM IDC plug insert crimp pliers mounting instructions

Tool information

RJ45 pin No.	Connection		Application					
	Colour Code T568		DIN 47100	Industrial PROFINET	10BT/100BT	1 - 10 Gigabit Ethernet	Token Ring ISDN/So	Upo/TEL
	A	B						
1	WH-GN	WH-OG	WH	YE	●	●		
2	GN	OG	BN	OG	●	●		
3	WH-OG	WH-GN	GN	WH	●	●	●	
4	BU	BU	YE	—		●	●	●
5	WH-BU	WH-BU	GY	—		●	●	●
6	OG	GN	PK	BU	●	●	●	
7	WH-BN	WH-BN	BU	—		●		
8	BN	BN	RD	—		●		



Legend: BU = blue GY = grey PK = pink WH = white
 BN = brown GN = green OG = orange RD = red YE = yellow

Inserts	Pages
CX 8 J6IM	A.32, C.71

COPZ – COST

Data connectors tools

for coaxial RF contacts

Item	Description	Part No.
	Manual crimping tool for CX 50 R and CX 75 R coaxial contacts	COPZ
	Coaxial cable stripper for the preparation of the cable according to the drawing	COST

Crimping instructions

- 1) Strip the cable as per drawing using the tool **COST**.
- 2) Crimp the central contact of coaxial connector in the correct crimping area with the position 0,72 of crimping tool **COPZ**.
- 3) Insert the brass back end on the cable.
- 4) Insert the central contact in the coaxial connector, put the braid shield around the back cylinder of contact.
- 5) Insert the brass back end on the braid shield.
- 6) Crimp the ferrule with position 3,25 of crimping tool **COPZ**.

- It is recommended to use coding pins **CRM CX / CRF CX**;
- fit the brass tube on the cable;
- as alternative to crimping, it is possible to solder the central contact.





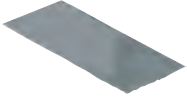


Tutorial

Contacts	Pages
CX 50 R	C.80
CX 75 R	C.80

CLPZ R

Data connectors tools

for POF / MOST® crimp contacts

Item	Description	Part No.
	Manual crimping tool for POF CX PL and MOST® CX ML contacts, RENNSTEIG model On request tool CLPZ RATIOPLAST 910 CZ 001 00 008 for POF and MOST® contacts crimping on the back	CLPZ R
	Polishing disc (RATIOPLAST 910 PS 0SC 00 001) for POF and MOST® contacts	CLDL
	Polish paper: grain size 1000 (RATIOPLAST 910 PB 001 00 001) grain size 4000 (RATIOPLAST 910 PB 001 40 250)	CLC1 CLC4
	Jacket stripper for POF and MOST® fibre optic with PA jacket (RATIOPLAST 910 AZ 001 00 PA1) Fibre stripper for POF fibre optic (RATIOPLAST 910 AB 001 00 001)	CLSG CLSP
	Cable cutter for Ø 2,3 mm max for POF and MOST® fibre optic (RATIOPLAST 910 SW 001 00 001)	CLTE

As alternative to crimping please use glue UHU PLUS ENDFEST 300 (BICOMPONENT), part No. "CL GL" (provide a strain relief by cable glands):

- mix the two components on a sheet (just a drop/each)
- the stripped ca. 5 mm POF (that means the inner fibre) has to be dipped in the glue (just 5 mm);
- the POF has to be pushed now in the contact/ferrule;
- min. one night to hard/dry the glue;
- finally the POF has to be polished (polishing disc).

Contacts	Pages
CX PLM / PLF	C.81
CX MLM / MLF	C.81

CLPZ R

use and maintenance instructions

General specifications

Strip the fibre about 12 mm for male contact and about 15 mm for female contact (see Figures 1 and 2).

Fig. 1 - Example of cable stripping for male crimp contact

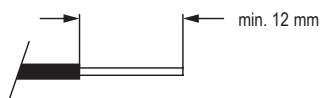
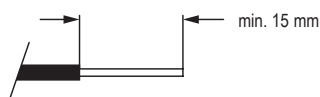


Fig. 2 - Example of cable stripping for female crimp contact



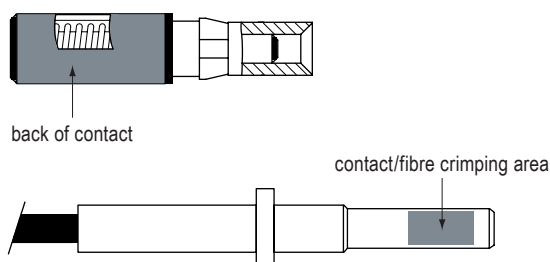
Crimping instructions

- The data sheet for crimping tool **CLPZ R** explains how the crimping tool works and how to adjust the crimping depth and locator for the contacts to be crimped. Position the turret on 3, push and turn of 90° the knob of turret. Adjust the crimping depth on 2 (unscrew the allen screw, after adjusting refix the screw). For the female contact: unscrew the back of the contact, pull out the internal central part; on Figure 4 is indicated the crimping area (front part of contact). For male contact: crimp the front part of contact.
- Push the stripped fibre as far as possible into the contact sleeve so that it protrudes approx. 1 mm from the tip of the contact.

Fig. 3 - Male contact/fibre crimping area

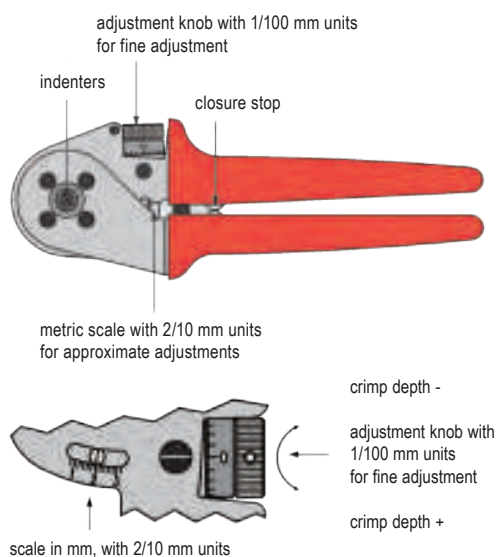


Fig. 4 - Female contact/fibre crimping area



- Insert the contact together with the fibre optic cable as far as possible into the crimping opening of the crimping tool (**CLPZ R**, see Figure 5) while applying gentle pressure to the fibre optic cable and connector, close the tool until you hear it disengages.

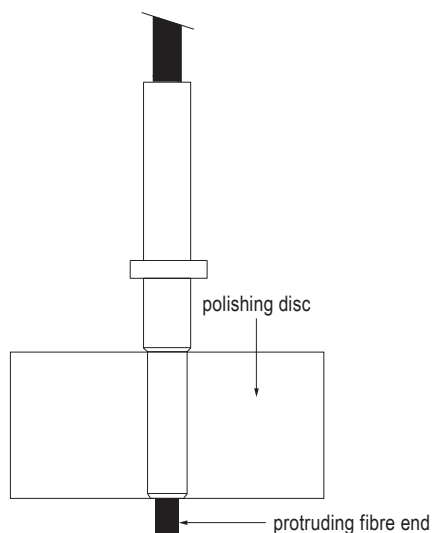
Fig. 5 (manual crimping tool)



Finishing the front surface

- Insert the contact into the polishing disc (**CLDL**) as shown in Figure 6. Work on a smooth surface (such as a sheet of glass), use grade 1000 polishing paper to grind off the protruding fibre and polish it with grade 4000 polishing paper.
- Wipe away any residue remaining after grinding. The best optical attenuation values are achieved when a wet grinding method is used.

Fig. 6 - Polishing Disc with Guide for Connector Sleeve





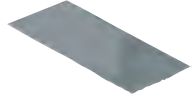


Final mounting instructions

Screw the back female part contact. Put inside the CX 04 LF/ CX 04 LM insert.

CLPZ R

Data connectors tools

for POF CL series contacts

Item	Description	Part No.
	Manual crimping tool for POF CLF DD / CLM DD contacts RENNSTEIG model crimping tool	CLPZ R
	Polishing disc (RATIOPLAST 910 PS 0SC 00 001) for POF contacts	CLDL DD
	Polish paper: grain size 1000 (RATIOPLAST 910 PB 001 00 001) grain size 4000 (RATIOPLAST 910 PB 001 40 250)	CLC1 CLC4
	Jacket stripper for POF fibre optic with PA jacket (RATIOPLAST 910 AZ 001 00 PA1) Fibre stripper for POF fibre optic (RATIOPLAST 910 AB 001 00 001)	CLSG CLSP
	Cable cutter for Ø 2,3 mm max for POF fibre optic (RATIOPLAST 910 SW 001 00 001)	CLTE

TOOLS

F

Contacts	Pages
CLM DD / CLF DD	F.21

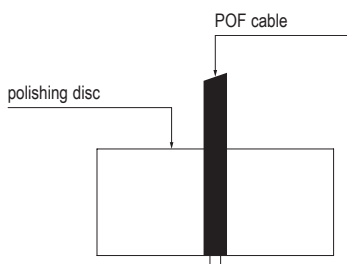
CLPZ R

use and maintenance instructions

Finishing the front surface of the fibre optic

- Before crimping, insert POF fibre optic into the polishing disc (CLDL DD) as shown in Fig. 1.
 - Work on a smooth surface (such as a sheet of glass), use grade 1000 polishing paper to grind off the protruding fibre and polish it with grade 4000 polishing paper.
 - Polish making 8-shape circles.
 - Wipe away any residue remaining after grinding.
- The best optical attenuation values are achieved when a wet grinding method is used.

Fig. 1 - Polishing Disc with Guide for POF fibre



General specifications

Strip the fibre 19 mm for male contact and 14 mm for female contact (refer to Figures 2 and 3).

Fig. 2 - Example of cable stripping for male crimp contact

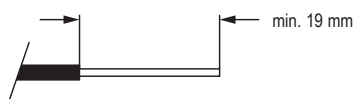
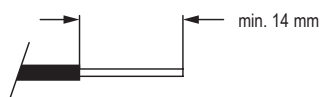


Fig. 3 - Example of cable stripping for female crimp contact



Crimping instructions

- The CLPZ R crimping tool data sheet explains how the crimping tool works and how to adjust the crimping depth and locator to crimp the contacts as shown in Fig. 4.
- Select position no. 1 on the turret (for male contact) and no. 2 (for female contact), push and turn of 90° the knob of the turret.
- Adjust the crimping depth on 1,45 (unscrew the allen screw, after adjusting refix the screw).
- Insert the contact together with the fibre optic cable as far as possible into the crimping opening of the crimping tool (CLPZ R, refer to Fig. 5) while applying gentle pressure to the fibre optic connector, close the tool until you hear it disengages.

Fig. 4 - Crimping area

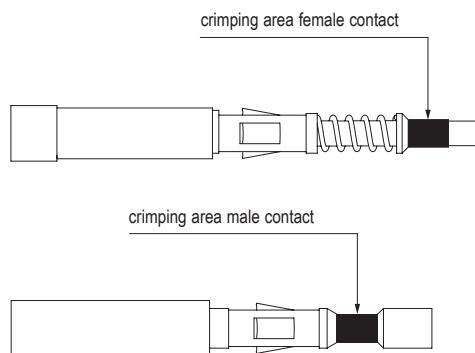
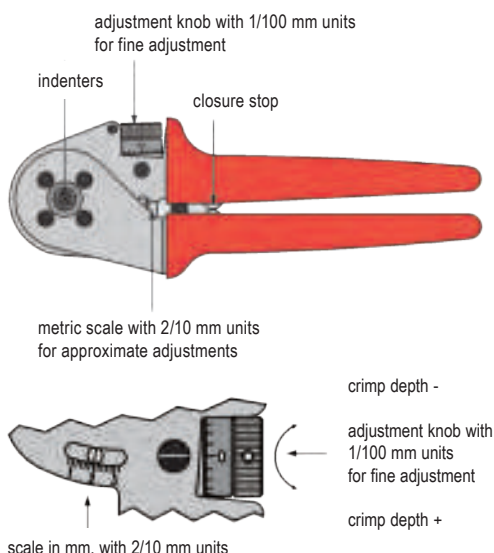


Fig. 5 (manual crimping tool)



Final mounting instructions

Screw the back female part contact. Put inside the CD/CDD/CX insert.

GENERAL CATALOGUE


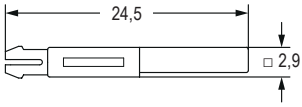

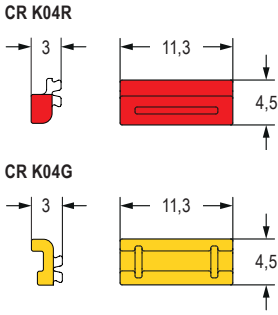
Accessories

Contents

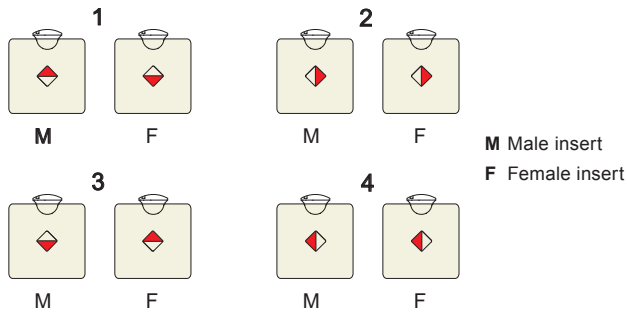
	Coding pins	G.2-15
	Bridges	G.16-18
	Termination connectors	G.19
	Cable anchorages	G.20-25
	Stainless-steel self-centring floating frames	G.26
	D-SUB adapter plates	G.27
	Crimp flanges and sleeves	G.28-29
	Closure and reduction plates	G.30
	Inserts joining block	G.31
	DIN rail mounting	G.32
	Screws	G.33
	Special enclosures	G.34-40
	Kit for control equipment	G.42
	Locking devices	G.43-44
	Counterflanges for V-TYPE and IP68 series	G.45
	Temporary protection cover	G.46-49

CR K03/CR K04

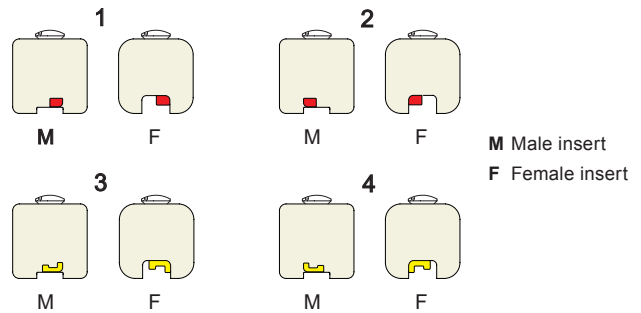
Coding pins

Item	Description	Part No.	Dimension
	Thermoplastic coding pin, 4 codings For CK/CKSH 03 inserts	CR K03	
	Red thermoplastic coding pin, For CK/CKSH 04 inserts Yellow thermoplastic coding pin For CK/CKSH 04 inserts	CR K04R CR K04G	

CR K03 coding options



CR K04 coding options


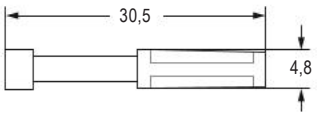

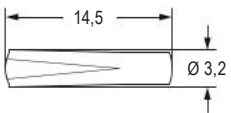

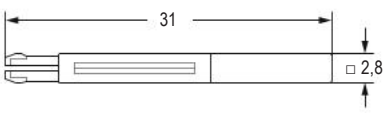


Inserts	Pages
CK 03 / CK 04	A.16
JK 03 / JK 04	A.17
CKD 03 / CKD 04	A.18
CKSH 03 / CKSH 04	A.19

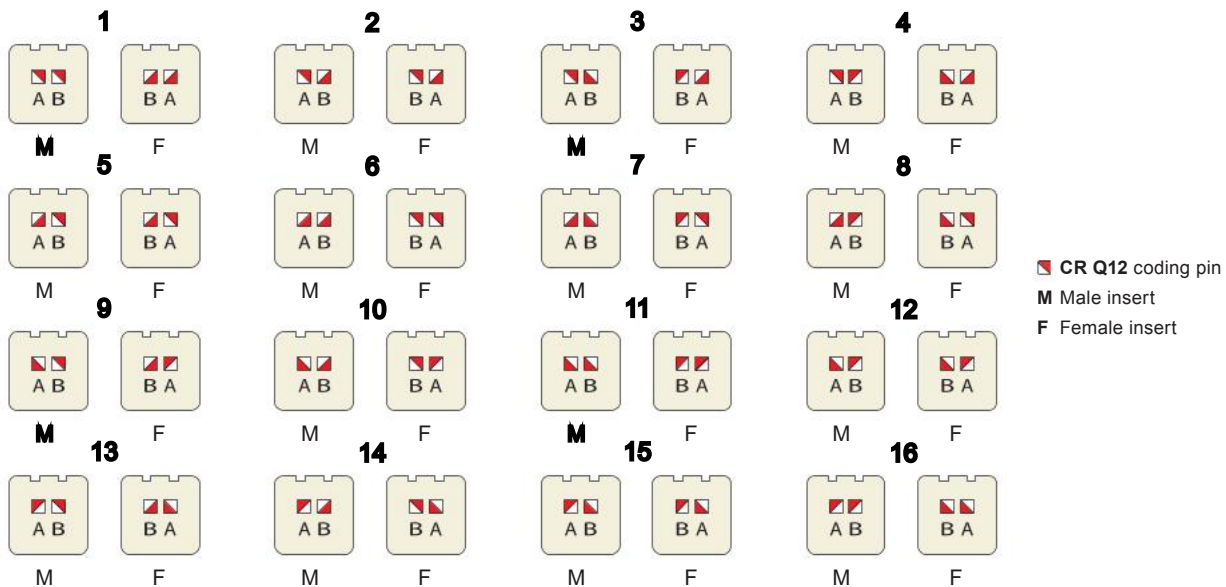


CR CP/CR Q12

Coding pins

Item	Description	Part No.	Dimension
	Thermoplastic coding pin For CDC, CQ 05, CQ 08, CQE, CQEE, HNM, CCE, CMCE and MIXO (16 A) inserts Pin to be inserted into one contact cavity of the female insert instead of the crimp contact, the male's corresponding insert must be left empty	CR CPQ	
	Thermoplastic coding pin For CD/CDD, HNM inserts Pin to be inserted into one contact cavity of the female insert instead of the crimp contact, the male's corresponding insert must be left empty	CR CP	
	Thermoplastic coding pin, 16 codings For CQ 12 inserts	CR Q12	

CR Q12 coding options




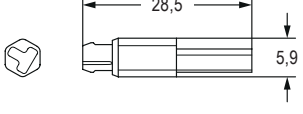

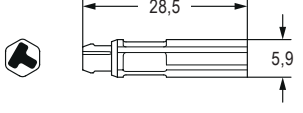
■ CR Q12 coding pin
 M Male insert
 F Female insert

Inserts	Pages
CR CPQ	
CQ 05	A.8
CQ 08	B.11
CDC	B.19-21
CCE	B.44-49
CQE / CQEE	B.72-79
CMCE	B.144-148
16 A MIXO modular inserts	C.39-45 53-54
CR CP	
CD 07 / CD 08	A.22 24
CD	B.30-32 90-93
CDD	B.33-34 94-96
CR Q12	
CQ 12	A.11

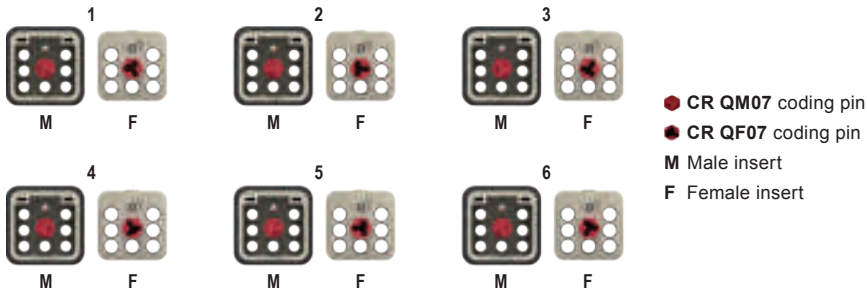
HNM inserts	Pages
CR CPQ	
RQ 05	H.7
RCE	H.10-13
RQEE	H.18-19
16 A HNM MIXO modular inserts	H.44-47
CR CP	
CD 08	H.9
RD	H.20-21
RDD	H.22-25

CR Q07

Coding pins

Item	Description	Part No.	Dimension
	Male thermoplastic coding pin, 6 codings For CQM 07 inserts	CR QM07	
	Female thermoplastic coding pin, 6 codings For CQF 07 inserts	CR QF07	

CR QM07 / CR QF07 coding options


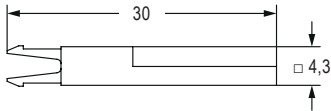


● CR QM07 coding pin
● CR QF07 coding pin
M Male insert
F Female insert

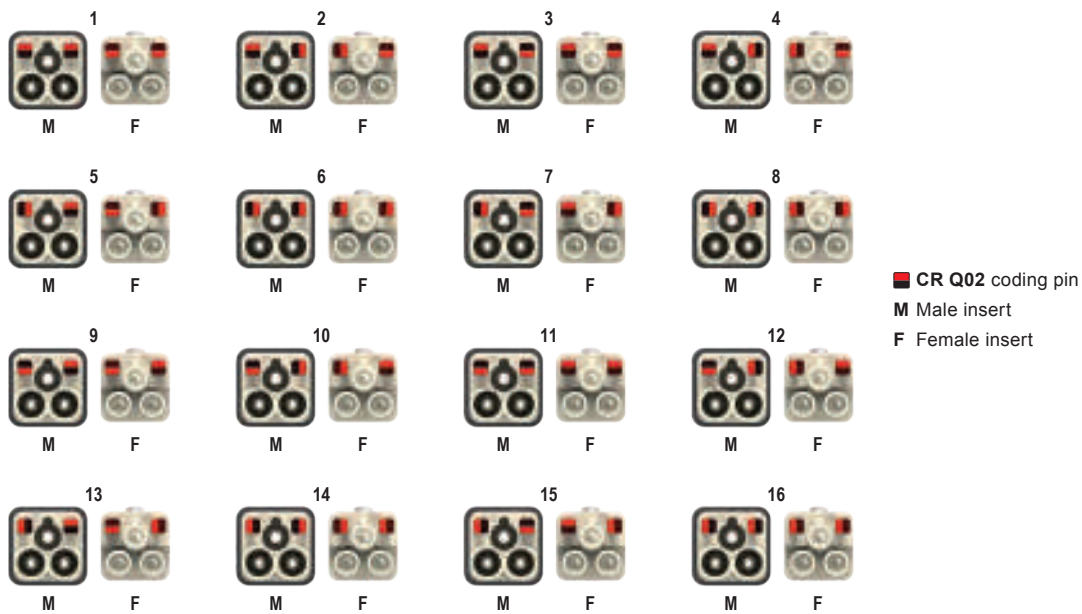
Inserts	Pages
CQ 07	A.10

CR Q02

Coding pins

Item	Description	Part No.	Dimension
	Thermoplastic coding pin, 16 codings For CQ4 02 inserts	CR Q02	

CR Q02 coding options


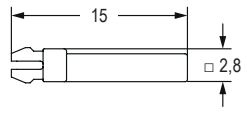


■ CR Q02 coding pin
M Male insert
F Female insert

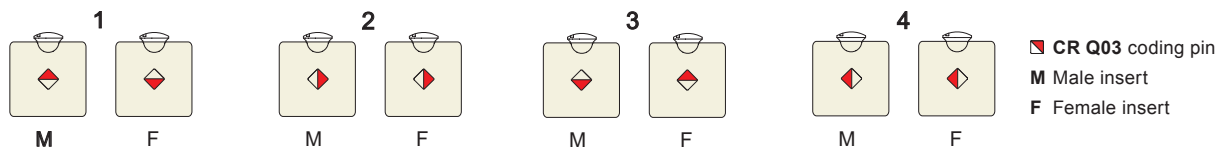
Inserts	Pages
CQ4 02 H	A.4
CQ4 02	A.5

CR Q03

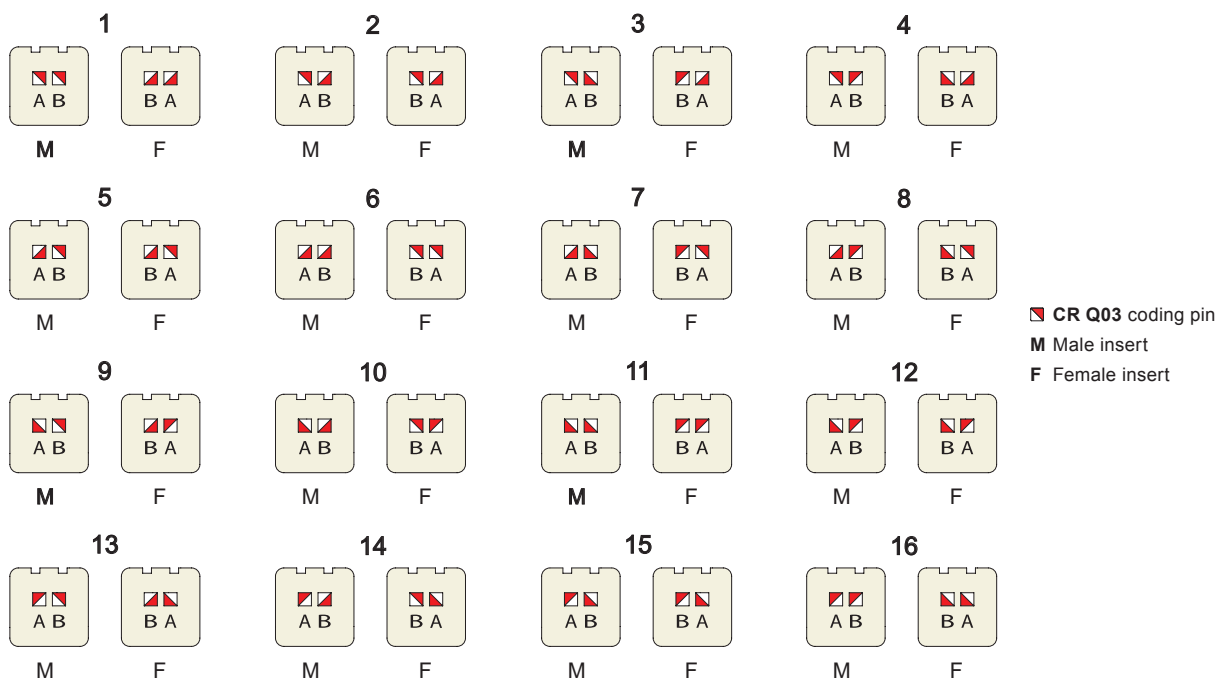
Coding pins

Item	Description	Part No.	Dimension
	Thermoplastic coding pin For CQ4 03 inserts and CQAM 12 T1 termination connectors	CR Q03	

CR Q03 coding options for CQ4 03 (1 pin)



CR Q03 coding options for CQAM 12 T1 (2 pins)


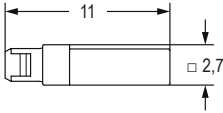


Inserts	Pages
CQ4 03	A.6
CQAM 12 T1	G.19
HNM inserts	Pages
CQ4 03	H.6




CR Q03/2

Coding pins

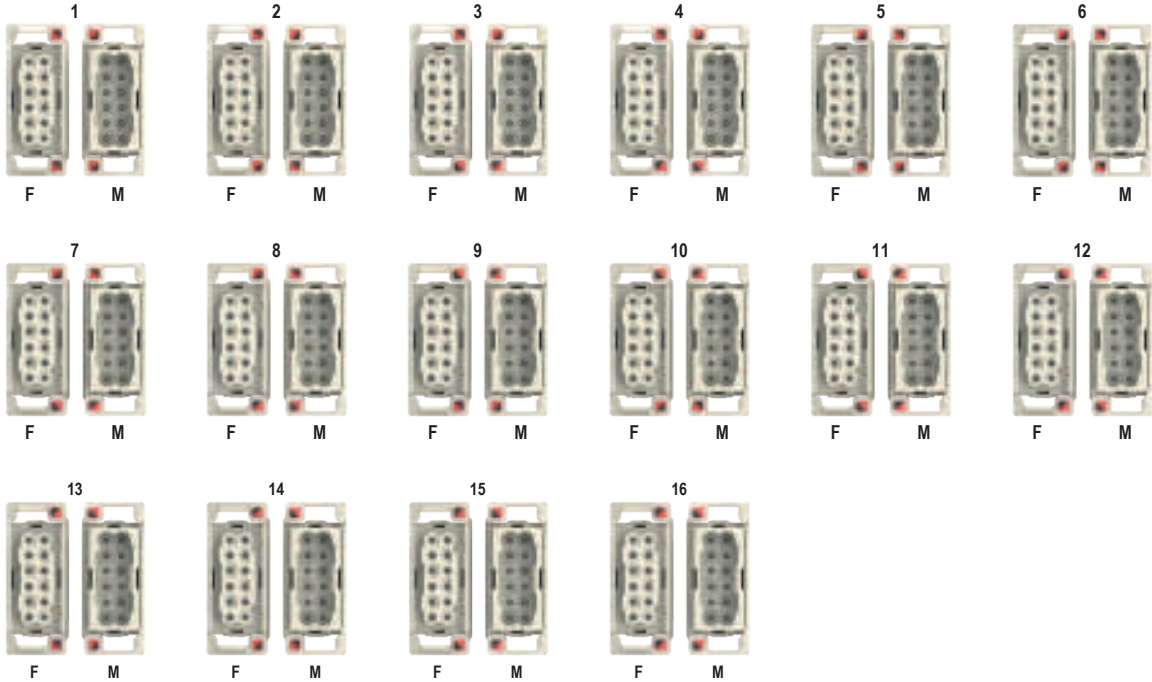
Item	Description	Part No.	Dimension
	Thermoplastic coding pin For CQ4 03/2 inserts and CX 01 TP MIXO holders	CR Q03/2	

CR Q03/2 coding options



■ CR Q03/2 coding pin
M Male insert
F Female insert

CR Q03/2 coding options available with CX 01 TP MIXO holders


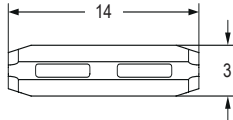


■ CR Q03/2 coding pin
M Male insert
F Female insert

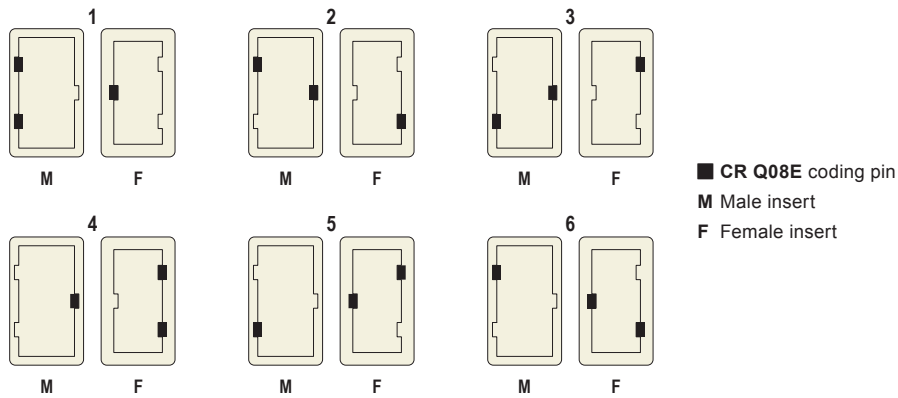
Inserts	Pages
CQ4 03/2	A.7
CX 01 TP	C.103

CR Q08E

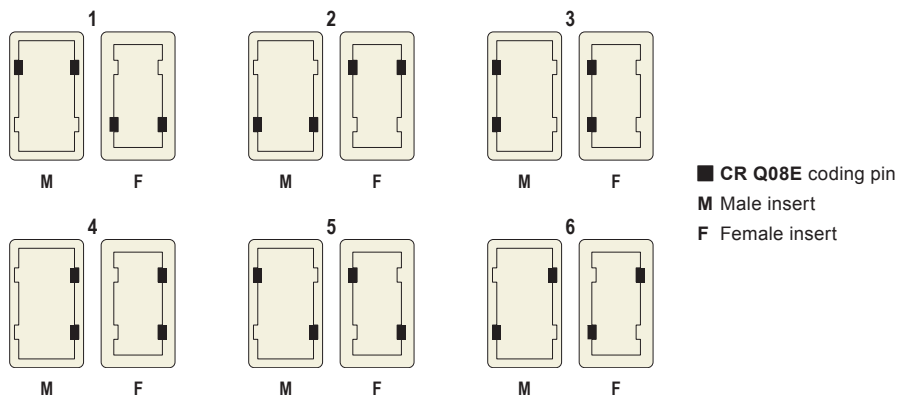
Coding pins

Item	Description	Part No.	Dimension
	Thermoplastic coding pin, 6 codings For CQ 08E , CQY 08E and CQEY inserts	CR Q08E	

CR Q08E coding options for CQEY 10 and CQEY 18 (3 pins)




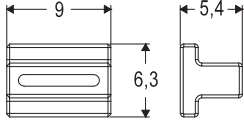
CR Q08E coding options for CQ 08E, CQY 08E, CQEY 32/32N and CQEY 46/46N (4 pins)



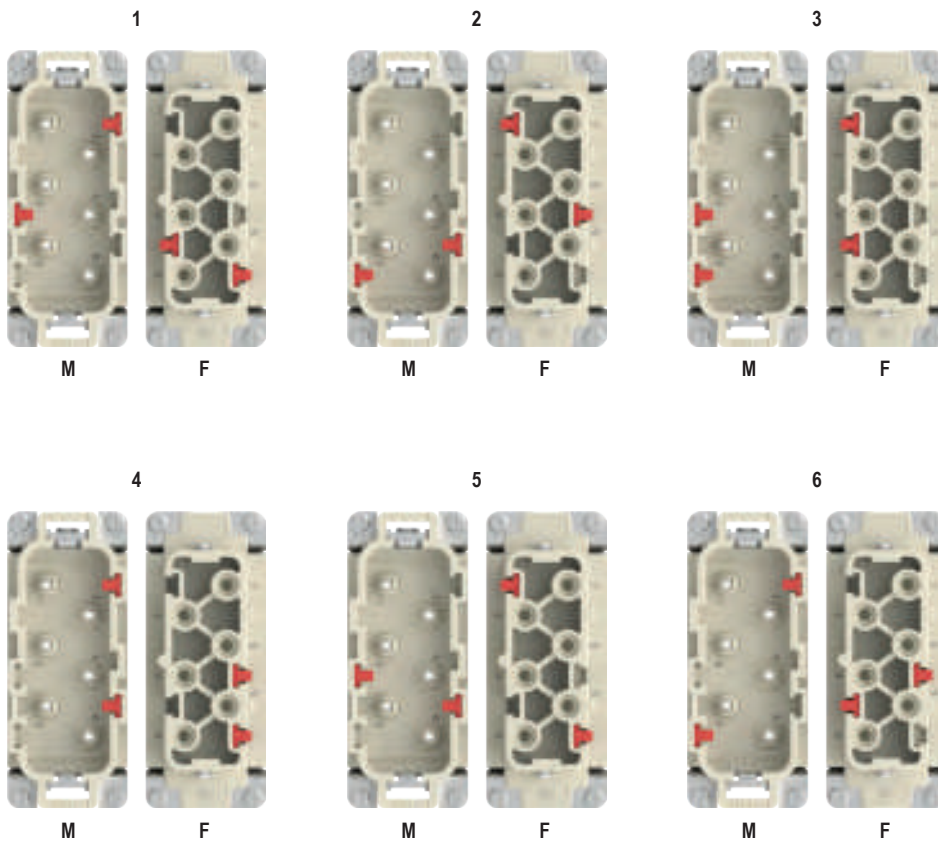
Inserts	Pages
CQ 08E	B.9
CQY 08E	B.10
CQEY	B.76-81

CR CPC

Coding pins

Item	Description	Part No.	Dimension
	Thermoplastic coding pin For CPY 06 inserts	CR CPC	


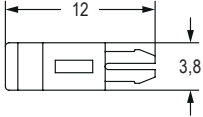
CR CPC coding options for CPY 06 (4 pins)



Inserts	Pages
CPY 06	B.114-115

CR CDS

Coding pins

Item	Description	Part No.	Dimension
	Thermoplastic coding pin For CDSH , CDSH 06 NC and HNM inserts	CR CDS	

CR CDS coding options


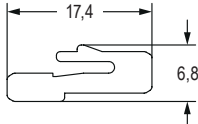


inserts size	9P + ⊕	18P + ⊕	27P + ⊕ 54P + ⊕	42P + ⊕ 84P + ⊕
slot for male and female coding pins	3 (M) + 3 (F)	6 (M) + 6 (F)	9 (M) + 9 (F) 18 (M) + 18 (F)	14 (M) + 14 (F) 28 (M) + 28 (F)
required coding pins for each coupling	3 pins = 2 (M) + 1 (F)	6 pins = 3 (M) + 3 (F)	9 pins = 5 (M) + 4 (F) 18 pins = 10 (M) + 8 (F)	14 pins = 7 (M) + 7 (F) 28 pins = 14 (M) + 14 (F)
possible codings	with 3 pins = 3	with 6 pins = 20	with 9 pins = 126 with 18 pins = 126 × 126	with 14 pins = 3.432 with 28 pins = 3.432 × 3.432

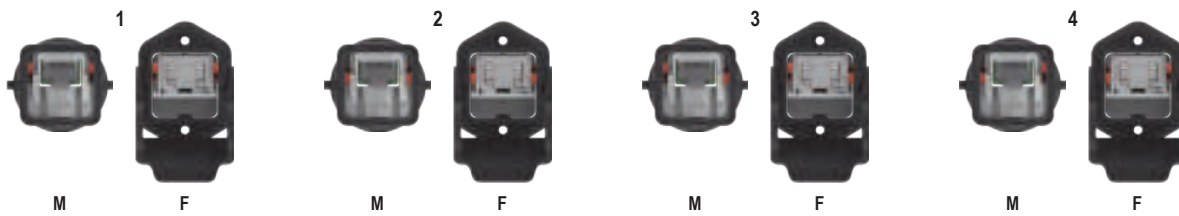
Inserts	Pages
CDSH	B.102-107
CDSH 06 NC	B.108
HNM inserts	Pages
RDSH	H.26-29

CR KC

Coding pins for RJ45 connectors

Item	Description	Part No.	Dimension
	Thermoplastic coding pin, 4 codings For RJ45 connectors	CR KC	

CR KC coding options



 CR KC coding pin


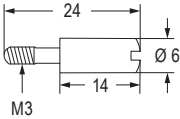

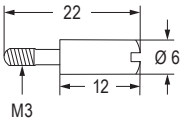
M Male insert

F Female insert

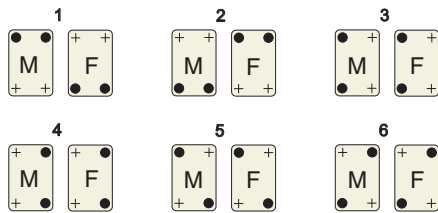
Inserts	Pages
RJ45 Cat. 5	A.30
RJ45 Cat. 6A	A.31-33
RJ45 Complete connectors, Cat. 5	A.40-42

CR 20

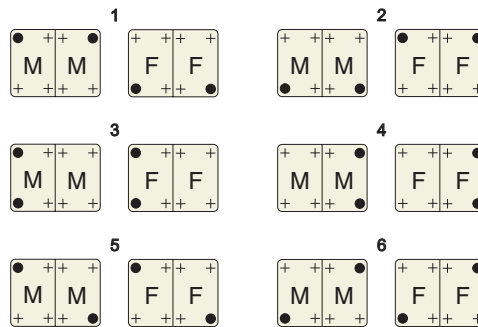
Coding pins

Item	Description	Part No.	Part No.	Dimension
	Single coding pin, 6 codings Single code pin Cannot be used with MIXO inserts	Stainless steel CR 20	Zinc plated steel CR 20 D	
	Single coding pin, 6 codings Single code pin To be used only with MIXO inserts	Stainless steel CR 20 CX	Zinc plated steel CR 20 CX D	

CR coding options – application with single insert



CR coding options – application with double insert



- Coding pin (CR 20/CR 20 D and CR 20 CX/CR 20 CX D)
- + Normal fixing screw
- M Male insert
- F Female insert

Inserts	Pages
Sizes 49.16 to 66.40	B.16-34
Sizes 44.27 to 104.62	B.38-171
HNM inserts, sizes 44.27 to 104.27	H.10-32
Accessories	Pages
Frames for modular units	C.94-95
Frames for HNM modular units	H.62

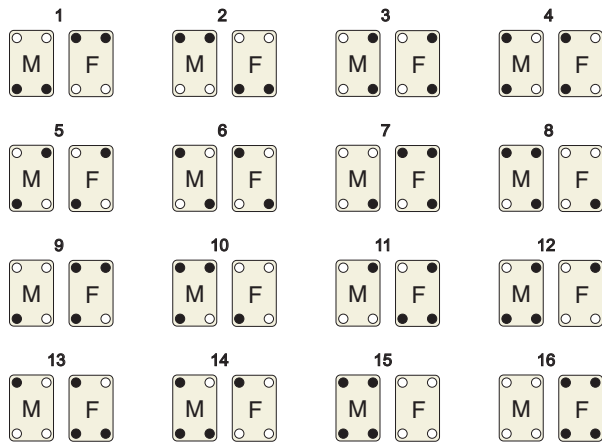


CR

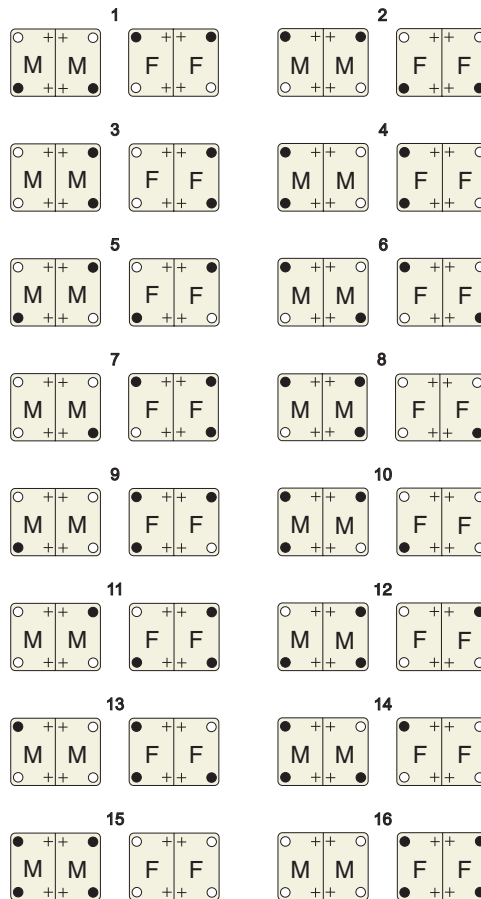
Coding pins - 16 codings

Item	Description	Part No.	Part No.	Dimension
	Coding and guiding pins, 16 codings Male coding pin Female coding pin Cannot be used with MIXO inserts	Stainless steel CRM CRF	Zinc plated steel CRM D CRF D	CRM/CRM D CRF/CRF D
	Coding and guiding pins, 16 codings Male coding pin Female coding pin To be used only with MIXO inserts	Stainless steel CRM CX CRF CX	Zinc plated steel CRM CX D CRF CX D	CRM CX/CRM CX D CRF CX/CRF CX D

CR coding options – application with single insert



CR coding options – application with double insert


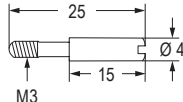
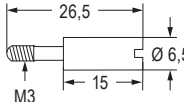
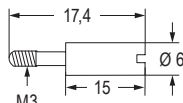

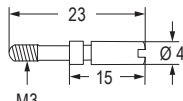
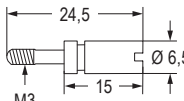
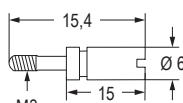


- Male coding and guiding pins: **CRM / CRM D** and **CRM CX / CRM CX D**
- Female coding and guiding pins: **CRF / CRF D** and **CRF CX / CRF CX D**
- + Normal fixing screw
- M Male insert
- F Female insert

Inserts	Pages
Sizes 49.16 to 66.40	B.16-34
Sizes 44.27 to 104.62	B.38-171
HNM inserts, sizes 44.27 to 104.27	H.10-32
Accessories	Pages
Frames for modular units	C.94-95
Frames for HNM modular units	H.62

CR

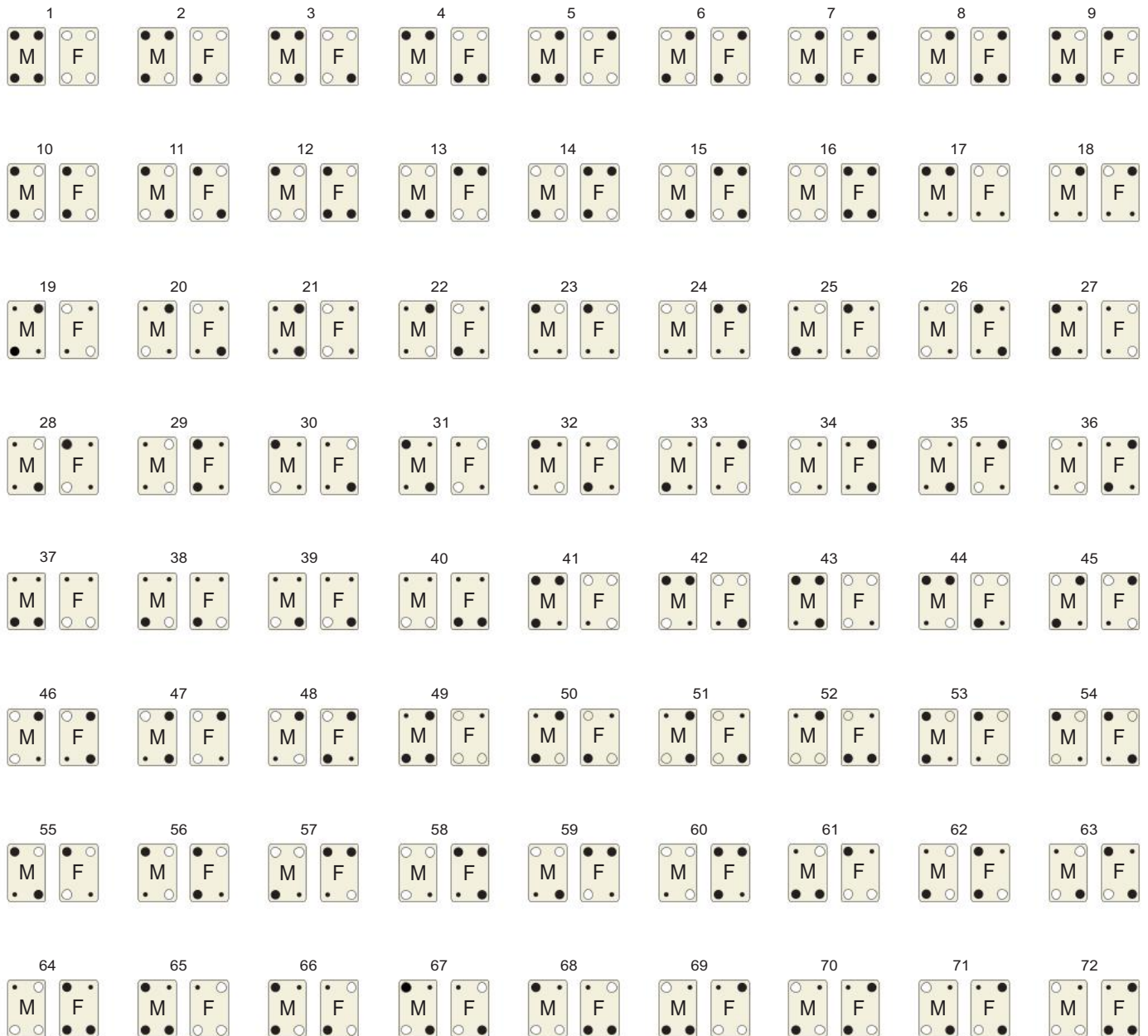
Coding pins - 72 codings

Item	Description	Part No.	Part No.	Dimension
	Coding and guiding pins, 72 codings Male coding pin Female coding pin Single code pin Cannot be used with MIXO inserts	Stainless steel CRM CRF CR 72	Zinc plated steel CRM D CRF D CR 72 D	<div style="display: flex; justify-content: space-around;"> <div style="text-align: center;"> <p>CRM/CRM D</p>  </div> <div style="text-align: center;"> <p>CRF/CRF D</p>  </div> </div> <div style="text-align: center; margin-top: 10px;"> <p>CR 72/CR 72 D</p>  </div>
	Coding and guiding pins, 72 codings Male coding pin Female coding pin Single code pin To be used only with MIXO inserts	Stainless steel CRM CX CRF CX CR 72 CX	Zinc plated steel CRM CX D CRF CX D CR 72 CX D	<div style="display: flex; justify-content: space-around;"> <div style="text-align: center;"> <p>CRM CX/CRM CX D</p>  </div> <div style="text-align: center;"> <p>CRF CX/CRF CX D</p>  </div> </div> <div style="text-align: center; margin-top: 10px;"> <p>CR 72 CX/CR 72 CX D</p>  </div>

Inserts	Pages
Sizes 49.16 to 66.40	B.16-34
Sizes 44.27 to 104.62	B.38-171
HNM inserts, sizes 44.27 to 104.27	H.10-32
Accessories	Pages
Frames for modular units	C.94-95
Frames for HNM modular units	H.62




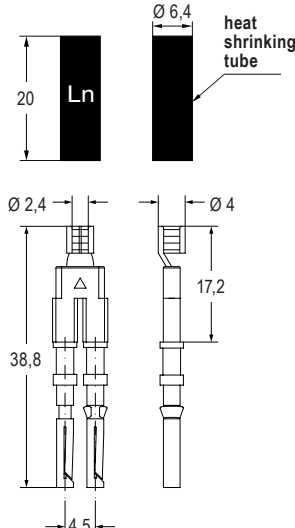
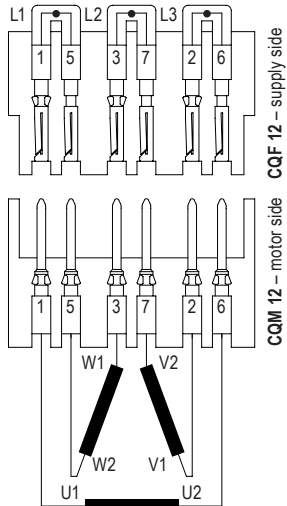
CR coding options – application with single insert



- Male coding and guiding pins: **CRM / CRM D** and **CRM CX / CRM CX D**
- Female coding and guiding pins: **CRF / CRF D** and **CRF CX / CRF CX D**
- Single code pins: **CR 72 / CR 72 D** and **CR 72 CX / CR 72 CX D**
- M Male insert
- F Female insert

CR BDE

Bridges for delta connection

Item	Description	Part No.	Dimension																				
 <p>Bridge with 2 female 10 A contacts, silver plated, for delta connection</p> <p>Example of delta connection using CQF 12</p> <p>The typical use of the product requires three bridges each with its shrinking tube with L1 / L2 / L3 marking to identify the phases in the wiring</p>	<p>CR BDE</p>																						
			<table border="1"> <tbody> <tr> <td>1-5</td> <td>Bridge L1 (winding U1 / W2)</td> <td>9</td> <td>auxiliary circuit</td> </tr> <tr> <td>2-6</td> <td>Bridge L2 (winding V1 / U2)</td> <td>10</td> <td>auxiliary circuit</td> </tr> <tr> <td>3-7</td> <td>Bridge L3 (winding W1 / V2)</td> <td>11</td> <td>auxiliary circuit</td> </tr> <tr> <td>4</td> <td>auxiliary circuit</td> <td>12</td> <td>auxiliary circuit</td> </tr> <tr> <td>8</td> <td>auxiliary circuit</td> <td>⊕</td> <td>protective earth</td> </tr> </tbody> </table>	1-5	Bridge L1 (winding U1 / W2)	9	auxiliary circuit	2-6	Bridge L2 (winding V1 / U2)	10	auxiliary circuit	3-7	Bridge L3 (winding W1 / V2)	11	auxiliary circuit	4	auxiliary circuit	12	auxiliary circuit	8	auxiliary circuit	⊕	protective earth
1-5	Bridge L1 (winding U1 / W2)	9	auxiliary circuit																				
2-6	Bridge L2 (winding V1 / U2)	10	auxiliary circuit																				
3-7	Bridge L3 (winding W1 / V2)	11	auxiliary circuit																				
4	auxiliary circuit	12	auxiliary circuit																				
8	auxiliary circuit	⊕	protective earth																				

ACCESSORIES



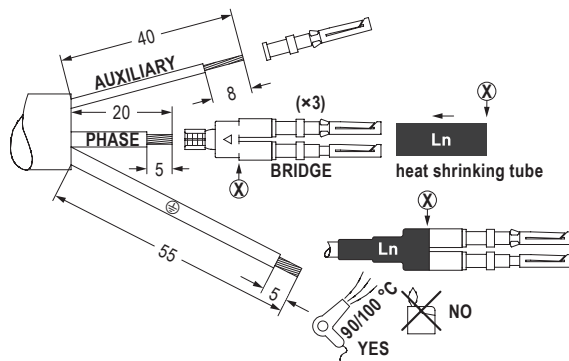
Crimp pliers for CR BDE bridges, CEMBRE IDT model. For wires with cross section ranging from 1,5 to 2,5 mm² (AWG 16-14)

CRPZ

Matrix for CRPZ crimp pliers

CRD

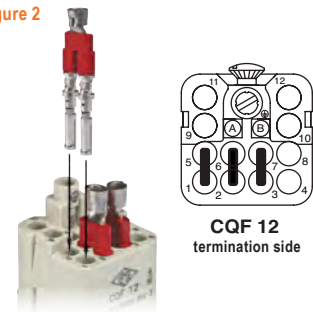
Figure 1



Assembly instructions

- 1) Cut and strip the wires as shown in Figure 1.
- 2) Crimp the contacts on the auxiliary wires and the bridge end to the phase wires (3 units) using CRPZ pliers and CRD matrix (position 2,5).
- 3) Insert the insulating heat shrinking tubes on the bridges, their end must be aligned with the position ⊗. Then heat them at 90/100 °C till they shrink over the wires.
- 4) Insert the 3 bridges according to the Figure 2.

Figure 2



Inserts	Pages
CQF 12	A.11
CDDF	B.94-99
CX 17 DF	C.48

CR BST

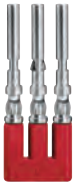
Bridges for star connection

Item

Description

Part No.

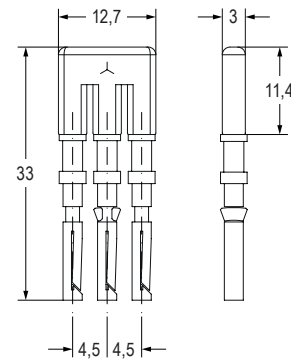
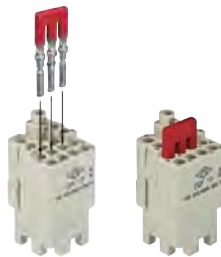
Dimension



Bridge with 3 female 10 A contacts, silver plated, for star connection

[CR BST](#)

Example of star connection using CQF 12



5-6-7 Bridge W2 / U2 / V2

1 L1

2 L2

3 L3

4 auxiliary circuit

8 auxiliary circuit

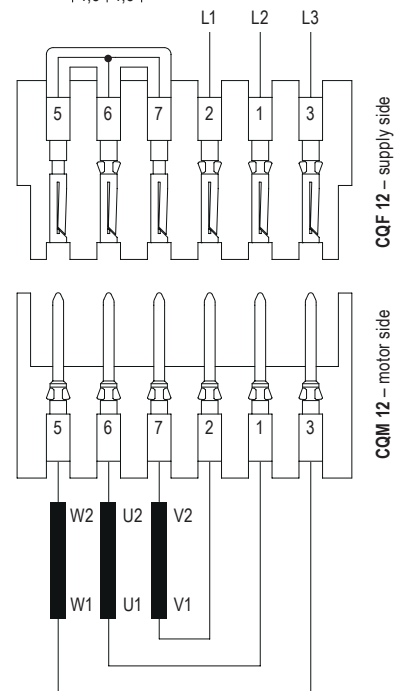
9 auxiliary circuit

10 auxiliary circuit

11 auxiliary circuit

12 auxiliary circuit

⊕ protective earth



Inserts

Pages

CQF 12

A.11

CDDF

B.94-99


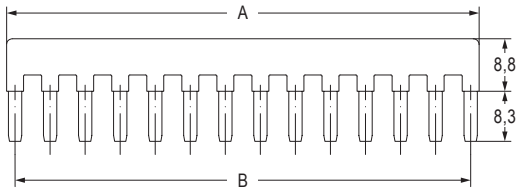
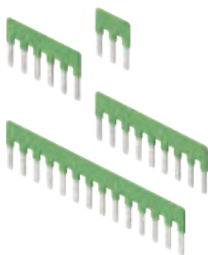
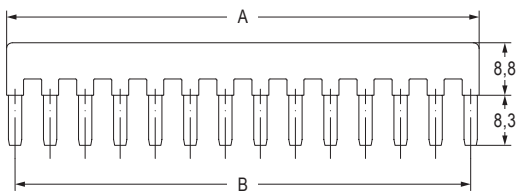
CX 17 DF

C.48

CR BDSH

Parallel bridges for CDSH inserts

EN 61984 rating **10 A 50 V 0,8 kV 3**
 Ambient temperature limit **-40 °C ... +125 °C**

Item	Description	Part No.	Dimension																				
	Parallel bridge, light blue colour, 3 pin	CR BDSH3A																					
	Parallel bridge, light blue colour, 6 pin	CR BDSH6A																					
	Parallel bridge, light blue colour, 9 pin	CR BDSH9A																					
	Parallel bridge, light blue colour, 14 pin	CR BDSH14A																					
	To be used only with un-ferruled conductors up to 1,5 mm ² (16 AWG).		<table border="1"> <thead> <tr> <th>Part No.</th> <th>n° of pins</th> <th>A (mm)</th> <th>B (mm)</th> </tr> </thead> <tbody> <tr> <td>CR BDSH3A</td> <td>3</td> <td>14,6</td> <td>11,6</td> </tr> <tr> <td>CR BDSH6A</td> <td>6</td> <td>32</td> <td>29</td> </tr> <tr> <td>CR BDSH9A</td> <td>9</td> <td>49,4</td> <td>48,4</td> </tr> <tr> <td>CR BDSH14A</td> <td>14</td> <td>78,4</td> <td>75,4</td> </tr> </tbody> </table>	Part No.	n° of pins	A (mm)	B (mm)	CR BDSH3A	3	14,6	11,6	CR BDSH6A	6	32	29	CR BDSH9A	9	49,4	48,4	CR BDSH14A	14	78,4	75,4
Part No.	n° of pins	A (mm)	B (mm)																				
CR BDSH3A	3	14,6	11,6																				
CR BDSH6A	6	32	29																				
CR BDSH9A	9	49,4	48,4																				
CR BDSH14A	14	78,4	75,4																				
	Parallel bridge, green colour, 3 pin	CR BDSH3G																					
	Parallel bridge, green colour, 6 pin	CR BDSH6G																					
	Parallel bridge, green colour, 9 pin	CR BDSH9G																					
	Parallel bridge, green colour, 14 pin	CR BDSH14G																					
	To be used only with un-ferruled conductors up to 1,5 mm ² (16 AWG).		<table border="1"> <thead> <tr> <th>Part No.</th> <th>n° of pins</th> <th>A (mm)</th> <th>B (mm)</th> </tr> </thead> <tbody> <tr> <td>CR BDSH3G</td> <td>3</td> <td>14,6</td> <td>11,6</td> </tr> <tr> <td>CR BDSH6G</td> <td>6</td> <td>32</td> <td>29</td> </tr> <tr> <td>CR BDSH9G</td> <td>9</td> <td>49,4</td> <td>48,4</td> </tr> <tr> <td>CR BDSH14G</td> <td>14</td> <td>78,4</td> <td>75,4</td> </tr> </tbody> </table>	Part No.	n° of pins	A (mm)	B (mm)	CR BDSH3G	3	14,6	11,6	CR BDSH6G	6	32	29	CR BDSH9G	9	49,4	48,4	CR BDSH14G	14	78,4	75,4
Part No.	n° of pins	A (mm)	B (mm)																				
CR BDSH3G	3	14,6	11,6																				
CR BDSH6G	6	32	29																				
CR BDSH9G	9	49,4	48,4																				
CR BDSH14G	14	78,4	75,4																				

Inserts	Pages
CDSH	B.102-107
HNM inserts	Pages
RDSH	H.26-29

The rated current applies to the conductor used to feed the **CR BDSH** parallel bridge, it applies to the above indicated maximum wire size and is distributed to all pins in parallel in a manner inversely proportional to the impedance of the served branch circuit. When all branches are with identical impedance, the current is equally divided by the number of served branches in parallel

CKM/CQAM


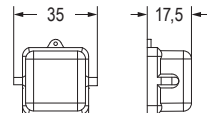

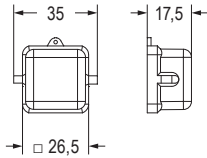


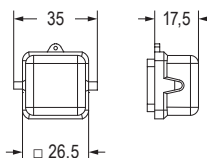

Termination connectors

EN 61984 rating

- CKM 03 T..	10 A	400 V	4 kV	3
- CQAM 12 T1	10 A	400 V	6 kV	3
	10 A	400 / 690 V	6 kV	2



CAIUS ECBT2.E115072 | ECBT8.E115072


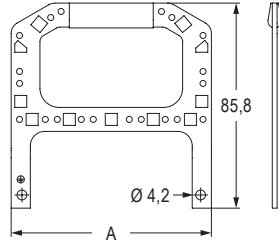

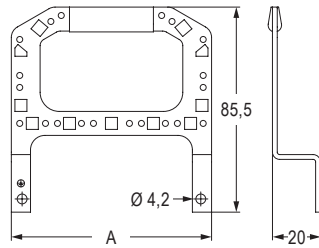

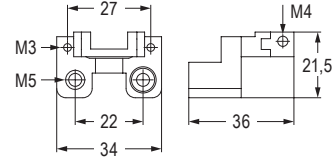

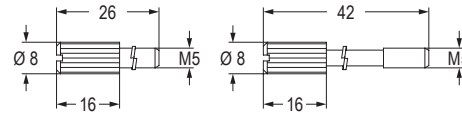

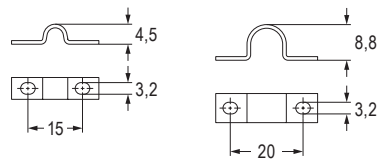
Item	Description	Part No.	Dimension
	Termination connector for CKF and CKSHF 03 inserts With pegs and seal Connects pole 2 with pole 3	CKM 03 T1	  <ul style="list-style-type: none"> interconnected 2-3 poles
	Termination connector for CKF and CKSHF 03 inserts With pegs and seal Connects pole 1 with pole 2 When the termination connector is mated with a CK..F 03 insert (complete with enclosure with lever), it performs a dual function, to connects two socket insert poles and to acts as a cover (IP65 protection rating compliant with EN 60529 standard)	CKM 03 T3	  <ul style="list-style-type: none"> interconnected 1-2 poles
	Termination connector for CQF 12 inserts With pegs and seal Connects pole 5 with pole 6 and pole 7 with pole 8 When the termination connector is mated with a CQF 12 insert (complete with enclosure with lever), it performs a dual function, to connects two socket insert poles and to acts as a cover (IP65 protection rating compliant with EN 60529 standard) CR Q03 coding pins can be used with CQAM 12 T1 . In this case the CQF 12 inserts must be provided with CR Q12 coding pins	CQAM 12 T1	  <ul style="list-style-type: none"> interconnected 5-6/7-8 poles

Inserts	Pages
CKF 03	A.16
JKF 03	A.17
CKFD 03	A.18
CKSHF 03	A.19
CQF 12	A.11

CR SS

Cable anchorages

size **77.27 – 104.27**

Item	Description	Part No.	Dimension
	<p>Cable anchorages shield, for: inserts size 77.27 – MIXO frames, 4 mod. units inserts size 104.27 – MIXO frames, 6 mod. units</p> <p>Cannot be used with CT, CTS and CTSE inserts</p> <p>CR ... SS anchorages (with grip to facilitate connector disconnection) are used for earth connecting of several conductors and/or of the screen of shielded cables.</p> <p>For use with CR SP supports, see note below this page.</p>	<p>CR 16 SS CR 24 SS</p>	 <p>Part No. A (mm) CR 16 SS 83,5 CR 24 SS 110</p>
	<p>Anchorage for cables outside enclosures, for: inserts size 77.27 – MIXO frames, 4 mod. units inserts size 104.27 – MIXO frames, 6 mod. units</p> <p>Cannot be used with CT, CTS and CTSE inserts</p> <p>CR ... SS anchorages (with grip to facilitate connector disconnection) are used for earth connecting of several conductors and/or of the screen of shielded cables.</p> <p>For use with CR SP supports, see note below this page.</p>	<p>CR 16 SSD CR 24 SSD</p>	 <p>Part No. A (mm) CR 16 SSD 83,5 CR 24 SSD 110</p>
	<p>Supports, for grip panels of cables outside enclosure, 2 pcs. Equipped with fixing screws and washers for earth connection</p>	<p>CR SP</p>	
	<p>Short screws in zinc iron, 2 pcs. Long screws in zinc iron, 2 pcs.</p>	<p>CR 26 V CR 42 V</p>	
	<p>Clamp for shielding cables Ø 5 mm Clamp for shielding cables Ø 10 mm To be mounted on CR ... SS earthing terminals</p>	<p>CR 05 CA CR 10 CA</p>	

Materials	
Anchorage	zinc plated steel
Supports	die-cast zinc

Inserts	Pages
Standard inserts, sizes 77.27 and 104.27	B.40-171
HNM inserts, sizes 77.27 and 104.27	H.12-32

Accessories	Pages
4- and 6-slot sized frames for modular units	C.95
4- and 6-slot sized frames for HNM modular units	H.62

In the fixed part, a pair of **CR SP** supports is fitted on the connector insert, using the insert's fixing screws. A **CR ... SS/SSD** anchorage is then fitted on the **CR SP** supports, using the supplied fixing screws and washers. All parts are secured on the rear panel with a pair of **CR 26 V** special short screws.


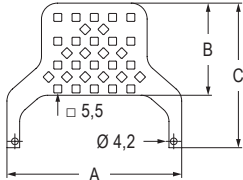

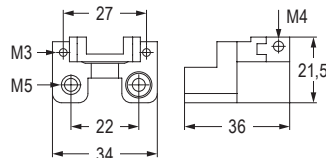

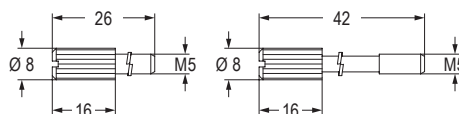
In the mobile part too, a pair of **CR SP** supports are fitted on the connector insert and a **CR ... SS/SSD** anchorage is secured on it. A pair of **CR 42 V** long screws fasten the free part to the fixed part.

By unscrewing the **CR 26 V** special short screws, the whole assembly (free part and fixed part) can be removed from the panel for inspection.

CR FS

Cable anchorages

size **44.27 – 104.27**

Item	Description	Part No.	Dimension																				
	<p>Cable anchorages shield, for: inserts size 44.27 – MIXO frames, 2 mod. units inserts size 57.27 – MIXO frames, 3 mod. units inserts size 77.27 – MIXO frames, 4 mod. units inserts size 104.27 – MIXO frames, 6 mod. units</p> <p>Cannot be used with CT, CTS and CTSE inserts</p> <p>The CR..FS series anchorages are employed for use of inserts (normal or MIXO modular) <u>without</u> enclosures and enable anchoring cables with clamps to prevent transmitting traction forces to contacts.</p> <p>For use with CR SP supports, see note below this page.</p>	<p>CR 06 FS CR 10 FS CR 16 FS CR 24 FS</p>	 <table border="1"> <thead> <tr> <th>Part No.</th> <th>A (mm)</th> <th>B (mm)</th> <th>C (mm)</th> </tr> </thead> <tbody> <tr> <td>CR 06 FS</td> <td>50</td> <td>25</td> <td>60</td> </tr> <tr> <td>CR 10 FS</td> <td>63</td> <td>25</td> <td>60</td> </tr> <tr> <td>CR 16 FS</td> <td>83,5</td> <td>35</td> <td>70</td> </tr> <tr> <td>CR 24 FS</td> <td>110</td> <td>58</td> <td>93</td> </tr> </tbody> </table>	Part No.	A (mm)	B (mm)	C (mm)	CR 06 FS	50	25	60	CR 10 FS	63	25	60	CR 16 FS	83,5	35	70	CR 24 FS	110	58	93
Part No.	A (mm)	B (mm)	C (mm)																				
CR 06 FS	50	25	60																				
CR 10 FS	63	25	60																				
CR 16 FS	83,5	35	70																				
CR 24 FS	110	58	93																				
	<p>Supports, for grip panels of cables outside enclosure, 2 pcs. Equipped with fixing screws and washers for earth connection</p>	<p>CR SP</p>																					
	<p>Short screws in zinc iron, 2 pcs. Long screws in zinc iron, 2 pcs.</p>	<p>CR 26 V CR 42 V</p>																					

Materials	
Anchorage	zinc plated steel
Supports	die-cast zinc

Inserts	Pages
Standard inserts, sizes 44.27 to 104.27	B.38-171
HNM inserts, sizes 44.27 to 104.27	H.10-32

Accessories	Pages
Frames for modular units	C.95
Frames for HNM modular units	H.62

In the fixed part, a pair of **CR SP** supports is fitted on the connector insert, using the insert's fixing screws. A **CR..FS** anchorage is then fitted on the **CR SP** supports, using the supplied fixing screws and washers. All parts are secured on the rear panel with a pair of **CR 26 V** special short screws.


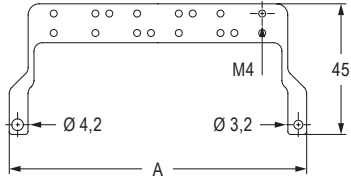
In the mobile part too, a pair of **CR SP** supports are fitted on the connector and a **CR..FS** anchorage is secured on it. A pair of **CR 42 V** long screws fasten the free part to the fixed part.


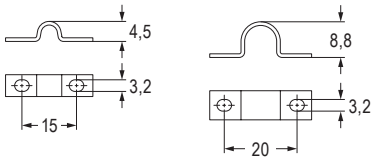
By unscrewing the **CR 26 V** special short screws, the whole assembly (free part and fixed part) can be removed from the panel for inspection.

CR ST

Cable anchorages

size **44.27 – 104.27**

Item	Description	Part No.	Dimension										
	<p>Shield earthing anchorage, for: enclosures 44.27 – MIXO frames, 2 mod. units enclosures 57.27 – MIXO frames, 3 mod. units* enclosures 77.27 – MIXO frames, 4 mod. units enclosures 104.27 – MIXO frames, 6 mod. units</p> <p>* fixed using the standard screws of the MIXO frame, the draw size are supplied with a special M4 screw that replaces the standard one.</p> <p>To be mounted on MIXO frames, in bulkhead mounting housings, COB series enclosures and high construction hoods with top entry</p>	<p>CR 06 ST CR 10 ST CR 16 ST CR 24 ST</p>	 <table border="1"> <thead> <tr> <th>Part No.</th> <th>A (mm)</th> </tr> </thead> <tbody> <tr> <td>CR 06 ST</td> <td>48</td> </tr> <tr> <td>CR 10 ST</td> <td>59,6</td> </tr> <tr> <td>CR 16 ST</td> <td>80</td> </tr> <tr> <td>CR 24 ST</td> <td>107</td> </tr> </tbody> </table>	Part No.	A (mm)	CR 06 ST	48	CR 10 ST	59,6	CR 16 ST	80	CR 24 ST	107
Part No.	A (mm)												
CR 06 ST	48												
CR 10 ST	59,6												
CR 16 ST	80												
CR 24 ST	107												

	<p>Clamp for shielding cables Ø 5 mm Clamp for shielding cables Ø 10 mm</p> <p>To be mounted in CR ... ST and CR ... STA earthing terminals.</p> <p>The diameter to consider is that of the cable shield (screen), not the outer overall one.</p>	<p>CR 05 CA CR 10 CA</p>	
---	--	---	---

Materials	
Anchorage	zinc plated steel

Accessories	Pages
Frames for modular units	C.95
Frames for HNM modular units	H.62

Anchorage **CR ... ST** are designed for installation on the frames of the MIXO modular units, for earth connecting the screening braid of shielded cables.

CR STA

Shield earthing anchorages

size **44.27 – 104.27**

Item	Description	Part No.	Dimension
	Shield earthing anchorages, high construction , for shielded cables, to be mounted in 44.27 enclosures and 2-slot sized MIXO frames To be mounted on MIXO frames in bulkhead mounting housing, IP68 series and BIG series	CR 06 STA	
	Shield earthing anchorages, high construction , for shielded cables, to be mounted in 57.27 enclosures and 3-slot sized MIXO frames To be mounted on MIXO frames in bulkhead mounting housing, IP68 series and BIG series	CR 10 STA	
	Shield earthing anchorages, high construction , for shielded cables, to be mounted in 77.27, 77.62 enclosures and 4-slot sized MIXO frames To be mounted on MIXO frames in bulkhead mounting housing, IP68 series and BIG series	CR 16 STA	
	Shield earthing anchorages, high construction , for shielded cables, to be mounted in 104.27, 104.62 enclosures and 6-slot sized MIXO frames To be mounted on MIXO frames in bulkhead mounting housing, IP68 series and BIG series	CR 24 STA	
	Clamp for shielding cables Ø 5 mm Clamp for shielding cables Ø 10 mm To be mounted in CR ... ST and CR ... STA earthing terminals. The diameter to consider is that of the cable shield (screen), not the outer overall one.	CR 05 CA CR 10 CA	


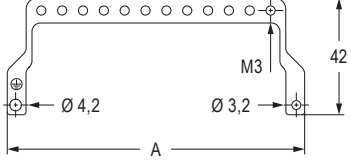

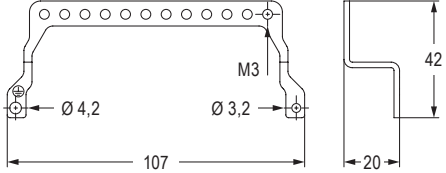
Materials	
Anchorage	zinc plated steel

Accessories	Pages
Frames for modular units	C.95
Frames for HNM modular units	H.62

CR AT

Cable anchorages

size **44.27 – 104.27**

Item	Description	Part No.	Dimension										
	<p>Anchorage for several PE connection cable, for: enclosures 44.27 – MIXO frames, 2 mod. units enclosures 57.27 – MIXO frames, 3 mod. units enclosures 77.27 – MIXO frames, 4 mod. units enclosures 104.27 – MIXO frames, 6 mod. units</p> <p>To be mounted on MIXO frames, in bulkhead mounting housings, COB series enclosures and high construction hoods with top entry</p>	<p>CR 06 AT CR 10 AT CR 16 AT CR 24 AT</p>	 <table border="1"> <thead> <tr> <th>Part No.</th> <th>A (mm)</th> </tr> </thead> <tbody> <tr> <td>CR 06 AT</td> <td>48</td> </tr> <tr> <td>CR 10 AT</td> <td>59,6</td> </tr> <tr> <td>CR 16 AT</td> <td>80</td> </tr> <tr> <td>CR 24 AT</td> <td>107</td> </tr> </tbody> </table>	Part No.	A (mm)	CR 06 AT	48	CR 10 AT	59,6	CR 16 AT	80	CR 24 AT	107
Part No.	A (mm)												
CR 06 AT	48												
CR 10 AT	59,6												
CR 16 AT	80												
CR 24 AT	107												
	<p>Zinc plated steel cable anchorage for: enclosures 104.27 – MIXO frames, 6 mod. units</p>	<p>CR 24 ATD</p>											

ACCESSORIES

G

Materials	
Anchorage	zinc plated steel


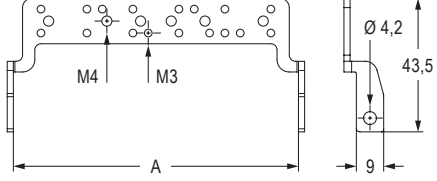

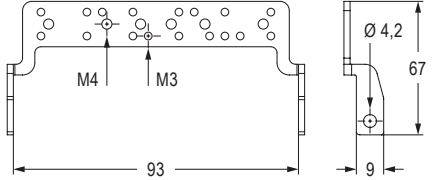

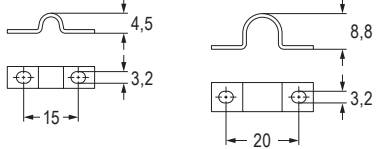
Anchorage **CR ... AT/ATD** are designed for installation on the frames of the MIXO modular units, for earth connecting several cables.

Accessories	Pages
Frames for modular units	C.95
Frames for HNM modular units	H.62

CR SC

Cable anchorages

size **44.27 – 104.27**


Item	Description	Part No.	Dimension
	<p>Ground terminal for shielding cables, for: enclosures and inserts size 44.27 enclosures and inserts size 57.27 enclosures and inserts size 77.27 enclosures and inserts size 104.27</p> <p>Cannot be used with CT, CTS and CTSE inserts</p> <p>To be mounted in bulkhead mounting housings, COB series enclosures and high construction hoods with top entry</p>	<p>CR 06 SC CR 10 SC CR 16 SC CR 24 SC</p>	 <p>Part No. A (mm)</p> <p>CR 06 SC 33</p> <p>CR 10 SC 46</p> <p>CR 16 SC 66,5</p> <p>CR 24 SC 93</p>
	<p>Ground terminal for shielding cables for CSS inserts size 104.27</p> <p>Can be used only in bulkhead mounting housings</p>	CR 24 SCA	
	<p>Clamp for shielding cables Ø 5 mm Clamp for shielding cables Ø 10 mm To be mounted on CR ... SC anchorages</p>	<p>CR 05 CA CR 10 CA</p>	
Materials	Anchorage zinc plated steel		

Inserts	Pages
Standard inserts, sizes 44.27 to 104.27	B.38-171
HNM inserts, sizes 44.27 to 104.27	H.10-32

CR..DF

Stainless-steel self-centring floating frames

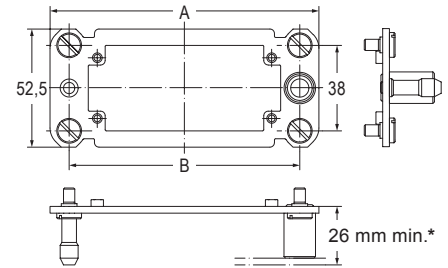
Mechanical life (cycles)	≥ 500
Compensation range	
- x axis	± 1,5 mm
- y axis	± 1,5 mm

Item	Description
	<p>Stainless steel frame, to be mounted on: inserts size 44.27 and MIXO frames, 2 inserts inserts size 57.27 and MIXO frames, 3 inserts inserts size 77.27 and MIXO frames, 4 inserts inserts size 104.27 and MIXO frames, 6 inserts</p> <p>Cannot be used with CT, CTS and CTSE inserts</p> <p>Supplied with 4 M5 shoulder screws with cylindrical head and notch to fix the frame in place</p> <p>As the frames are floating, the PE earthing connection of the metal surfaces on which they are mounted (mounting bases) must be performed separately and cannot be done by connecting the PE earthing contact to the corresponding connector inserts.</p>

Part No.

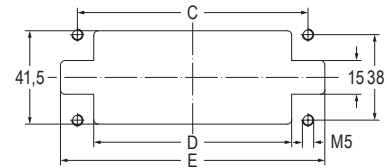
- [CR 06 DF](#)
- [CR 10 DF](#)
- [CR 16 DF](#)
- [CR 24 DF](#)

Dimension



*Distance for:
 - electric and fibre optic contacts: 26,5 mm max.;
 - pneumatic contacts: 26,5 mm max.

panel cut-out



Part No.	A (mm)	B (mm)	C (mm)	D (mm)	E (mm)
CR 06 DF	86	69	69	54,5	84
CR 10 DF	99	82	82	67,5	97
CR 16 DF	119,5	102,5	102,5	88	117,5
CR 24 DF	146	129	129	114,5	144

Materials	
Floating frame	stainless steel
Fixing screws	zinc-plated steel

Inserts	Pages
Standard inserts, sizes 44.27 to 104.27	B.38-171
HNM inserts, sizes 44.27 to 104.27	H.10-32

Accessories	Pages
Frames for modular units	C.95
Frames for HNM modular units	H.62


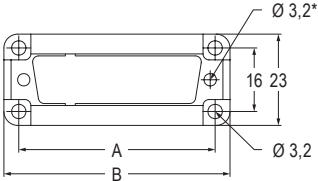
Designed to be used in the transportation, printing and power electronic industries (for example boxes for rack cabinets) and in all industrial applications that require, during assembly or maintenance, the connection of connectors without possibility of controlling the alignment.


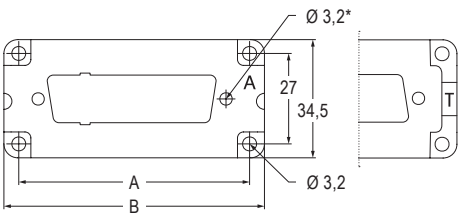

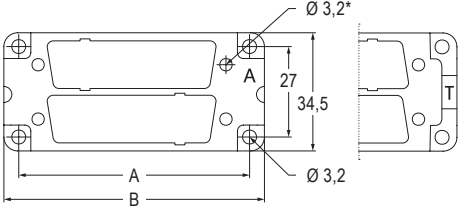
Enables the self-centring coupling of two corresponding connectors without the use of enclosures; they freely move on their base plate (± 1,5 mm on both axes) ensuring the alignment of the coupling.



CR AD

D-SUB adapter plates


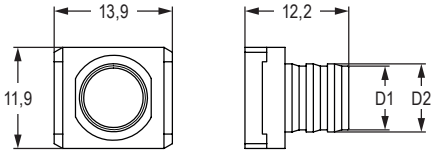
Item	Description	Part No.	Dimension												
	<p>Adapter plates for D-Sub inserts for CZ/MZ/MZF enclosures:</p> <p>Size 49.16: 1xD-Sub insert 9 poles Size 49.16: 1xD-Sub insert 15 poles Size 49.16: 1xD-Sub insert 25 poles Size 66.16: 1xD-Sub insert 37 poles Size 66.16: 1xD-Sub insert 50 poles</p> <p>D-Sub inserts not included Use M3 passing screws tightened with nuts and washers (not included)</p> <p>One-way mounting in bulkhead housings or hoods.</p>	<p>CR 09 AD CR 15 AD CR 25 AD CR 37 AD CR 50 AD</p>	 <table border="1"> <thead> <tr> <th>Part No.</th> <th>A (mm)</th> <th>B (mm)</th> <th>* for pass-through M3 screws</th> </tr> </thead> <tbody> <tr> <td>CR 09/15/25 AD</td> <td>49,5</td> <td>56,5</td> <td></td> </tr> <tr> <td>CR 37/50 AD</td> <td>66</td> <td>73,5</td> <td></td> </tr> </tbody> </table>	Part No.	A (mm)	B (mm)	* for pass-through M3 screws	CR 09/15/25 AD	49,5	56,5		CR 37/50 AD	66	73,5	
Part No.	A (mm)	B (mm)	* for pass-through M3 screws												
CR 09/15/25 AD	49,5	56,5													
CR 37/50 AD	66	73,5													

	<p>Adapter plates for D-Sub inserts for CH/MH/CA/MA/MF enclosures:</p> <p>Size 44.27: 1xD-Sub insert 9 poles Size 44.27: 1xD-Sub insert 15 poles Size 57.27: 1xD-Sub insert 25 poles Size 77.27: 1xD-Sub insert 37 poles Size 77.27: 1xD-Sub insert 50 poles</p>	<p>CR 09 AD1 CR 15 AD1 CR 25 AD1 CR 37 AD1 CR 50 AD1</p>	 <table border="1"> <thead> <tr> <th>Part No.</th> <th>A (mm)</th> <th>B (mm)</th> <th>* for pass-through M3 screws</th> </tr> </thead> <tbody> <tr> <td>CR 09/15 AD1</td> <td>44</td> <td>51,5</td> <td></td> </tr> <tr> <td>CR 25 AD1</td> <td>57</td> <td>64,5</td> <td></td> </tr> <tr> <td>CR 37/50 AD1</td> <td>77,5</td> <td>85</td> <td></td> </tr> </tbody> </table>	Part No.	A (mm)	B (mm)	* for pass-through M3 screws	CR 09/15 AD1	44	51,5		CR 25 AD1	57	64,5		CR 37/50 AD1	77,5	85	
Part No.	A (mm)	B (mm)	* for pass-through M3 screws																
CR 09/15 AD1	44	51,5																	
CR 25 AD1	57	64,5																	
CR 37/50 AD1	77,5	85																	
	<p>Adapter plates for D-Sub inserts for CH/MH/CA/MA/MF enclosures:</p> <p>Size 44.27: 2xD-Sub inserts 9 poles Size 44.27: 2xD-Sub inserts 15 poles Size 57.27: 2xD-Sub inserts 25 poles Size 77.27: 2xD-Sub inserts 37 poles Size 77.27: 2xD-Sub inserts 50 poles</p> <p>D-Sub inserts not included Use M3 passing screws tightened with nuts and washers (not included)</p> <p>Mounting on bulkhead housings The D-Sub connector must be mounted on the side marked with the letter "A"</p> <p>Mounting on hoods The D-Sub connector must be mounted on the side marked with the letter "T"</p>	<p>CR 09 AD2 CR 15 AD2 CR 25 AD2 CR 37 AD2 CR 50 AD2</p>	 <table border="1"> <thead> <tr> <th>Part No.</th> <th>A (mm)</th> <th>B (mm)</th> <th>* for pass-through M3 screws</th> </tr> </thead> <tbody> <tr> <td>CR 09/15 AD2</td> <td>44</td> <td>51,5</td> <td></td> </tr> <tr> <td>CR 25 AD2</td> <td>57</td> <td>64,5</td> <td></td> </tr> <tr> <td>CR 37/50 AD2</td> <td>77,5</td> <td>85</td> <td></td> </tr> </tbody> </table>	Part No.	A (mm)	B (mm)	* for pass-through M3 screws	CR 09/15 AD2	44	51,5		CR 25 AD2	57	64,5		CR 37/50 AD2	77,5	85	
Part No.	A (mm)	B (mm)	* for pass-through M3 screws																
CR 09/15 AD2	44	51,5																	
CR 25 AD2	57	64,5																	
CR 37/50 AD2	77,5	85																	

Enclosures	Pages
Slim enclosures sizes 49.16 and 66.16	E.14-43
Standard enclosures sizes 44.27, 57.27 and 77.27	E.48-301
HNM enclosures sizes 44.27, 57.27 and 77.27	H.74-79

CX..CF

Crimp flanges for MIXO shielded modules

Item	Description	Part No.	Dimension
	Crimp flanges, for MIXO shielded modules	CX 30.40CF	
		CX 35.45CF	
		CX 40.50CF	
		CX 45.55CF	
		CX 50.60CF	
		CX 55.65CF	
		CX 60.70CF	
		CX 65.75CF	
		CX 70.80CF	
		CX 76.85CF	
		CX 80.90CF	
		CX 85.95CF	
		CX 90.100CF	

Part No.	D1 (mm)	D2 (mm)
CX 30.40CF	3	4
CX 35.45CF	3,5	4,5
CX 40.50CF	4	5
CX 45.55CF	4,5	5,5
CX 50.60CF	5	6
CX 55.65CF	5,5	6,5
CX 60.70CF	6	7
CX 65.75CF	6,5	7,5
CX 70.80CF	7	8
CX 76.85CF	7,6	8,5
CX 80.90CF	8	9
CX 85.95CF	8,5	9,5
CX 90.100CF	9	10

Materials	
Crimp flanges	zinc die-cast


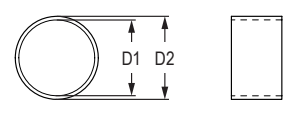

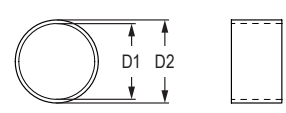

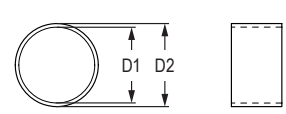

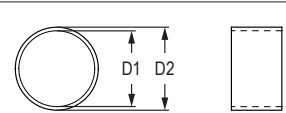
MIXO Modular Inserts	Pages
Cable clamps	C.61, H.56



Tutorial

CX..S

Crimp sleeves for MIX0 shielded modules

Item	Description	Part No.	Dimension																					
	<p>Crimp sleeves for CX..CF crimp flanges, from ID 5 mm/OD 6 mm to ID 7,5 mm/OD 8,5 mm</p> <p>ID: Inner Diameter OD: Outer Diameter</p> <p>Crimping tool, for crimp sleeves with diameter 6-8,5 mm</p>	<p>CX 50.60 S CX 55.65 S CX 60.70 S CX 65.75 S CX 70.80 S CX 75.85 S</p> <p>CCFPZ M2</p>	 <table border="1"> <thead> <tr> <th>Part No.</th> <th>D1 (mm)</th> <th>D2 (mm)</th> </tr> </thead> <tbody> <tr> <td>CX 50.60 S</td> <td>5</td> <td>6</td> </tr> <tr> <td>CX 55.65 S</td> <td>5,5</td> <td>6,5</td> </tr> <tr> <td>CX 60.70 S</td> <td>6</td> <td>7</td> </tr> <tr> <td>CX 65.75 S</td> <td>6,5</td> <td>7,5</td> </tr> <tr> <td>CX 70.80 S</td> <td>7</td> <td>8</td> </tr> <tr> <td>CX 75.85 S</td> <td>7,5</td> <td>8,5</td> </tr> </tbody> </table>	Part No.	D1 (mm)	D2 (mm)	CX 50.60 S	5	6	CX 55.65 S	5,5	6,5	CX 60.70 S	6	7	CX 65.75 S	6,5	7,5	CX 70.80 S	7	8	CX 75.85 S	7,5	8,5
Part No.	D1 (mm)	D2 (mm)																						
CX 50.60 S	5	6																						
CX 55.65 S	5,5	6,5																						
CX 60.70 S	6	7																						
CX 65.75 S	6,5	7,5																						
CX 70.80 S	7	8																						
CX 75.85 S	7,5	8,5																						
	<p>Crimp sleeves for CX..CF crimp flanges, from ID 8 mm/OD 9 mm to ID 10,5 mm/OD 11,5 mm</p> <p>ID: Inner Diameter OD: Outer Diameter</p> <p>Crimping tool, for crimp sleeves with diameter 9-11,5 mm</p>	<p>CX 80.90 S CX 85.95 S CX 90.100 S CX 95.105 S CX 100.110 S CX 105.115 S</p> <p>CCFPZ M1</p>	 <table border="1"> <thead> <tr> <th>Part No.</th> <th>D1 (mm)</th> <th>D2 (mm)</th> </tr> </thead> <tbody> <tr> <td>CX 80.90 S</td> <td>8</td> <td>9</td> </tr> <tr> <td>CX 85.95 S</td> <td>8,5</td> <td>9,5</td> </tr> <tr> <td>CX 90.100 S</td> <td>9</td> <td>10</td> </tr> <tr> <td>CX 95.105 S</td> <td>9,5</td> <td>10,5</td> </tr> <tr> <td>CX 100.110 S</td> <td>10</td> <td>11</td> </tr> <tr> <td>CX 105.115 S</td> <td>10,5</td> <td>11,5</td> </tr> </tbody> </table>	Part No.	D1 (mm)	D2 (mm)	CX 80.90 S	8	9	CX 85.95 S	8,5	9,5	CX 90.100 S	9	10	CX 95.105 S	9,5	10,5	CX 100.110 S	10	11	CX 105.115 S	10,5	11,5
Part No.	D1 (mm)	D2 (mm)																						
CX 80.90 S	8	9																						
CX 85.95 S	8,5	9,5																						
CX 90.100 S	9	10																						
CX 95.105 S	9,5	10,5																						
CX 100.110 S	10	11																						
CX 105.115 S	10,5	11,5																						
	<p>Crimp sleeves for CX..CF crimp flanges, from ID 11 mm/OD 12 mm to ID 12,5 mm/OD 13,5 mm</p> <p>ID: Inner Diameter OD: Outer Diameter</p> <p>Crimping tool, for crimp sleeves with diameter 12-13,5 mm</p>	<p>CX 110.120 S CX 115.125 S CX 120.130 S CX 125.135 S</p> <p>CCFPZ M3</p>	 <table border="1"> <thead> <tr> <th>Part No.</th> <th>D1 (mm)</th> <th>D2 (mm)</th> </tr> </thead> <tbody> <tr> <td>CX 110.120 S</td> <td>11</td> <td>12</td> </tr> <tr> <td>CX 115.125 S</td> <td>11,5</td> <td>12,5</td> </tr> <tr> <td>CX 120.130 S</td> <td>12</td> <td>13</td> </tr> <tr> <td>CX 125.135 S</td> <td>12,5</td> <td>13,5</td> </tr> </tbody> </table>	Part No.	D1 (mm)	D2 (mm)	CX 110.120 S	11	12	CX 115.125 S	11,5	12,5	CX 120.130 S	12	13	CX 125.135 S	12,5	13,5						
Part No.	D1 (mm)	D2 (mm)																						
CX 110.120 S	11	12																						
CX 115.125 S	11,5	12,5																						
CX 120.130 S	12	13																						
CX 125.135 S	12,5	13,5																						
	<p>Crimp sleeves for CX..CF crimp flanges, from ID 13 mm/OD 14 mm to ID 14 mm/OD 15 mm</p> <p>ID: Inner Diameter OD: Outer Diameter</p> <p>Crimping tool, for crimp sleeves with diameter 14-15 mm</p>	<p>CX 130.140 S CX 137.150 S CX 140.150 S</p> <p>CCFPZ M4</p>	 <table border="1"> <thead> <tr> <th>Part No.</th> <th>D1 (mm)</th> <th>D2 (mm)</th> </tr> </thead> <tbody> <tr> <td>CX 130.140 S</td> <td>13</td> <td>14</td> </tr> <tr> <td>CX 137.150 S</td> <td>13,7</td> <td>15</td> </tr> <tr> <td>CX 140.150 S</td> <td>14</td> <td>15</td> </tr> </tbody> </table>	Part No.	D1 (mm)	D2 (mm)	CX 130.140 S	13	14	CX 137.150 S	13,7	15	CX 140.150 S	14	15									
Part No.	D1 (mm)	D2 (mm)																						
CX 130.140 S	13	14																						
CX 137.150 S	13,7	15																						
CX 140.150 S	14	15																						

Materials

Crimp sleeves copper alloy

MIXO Modular Inserts

Cable clamps

Pages


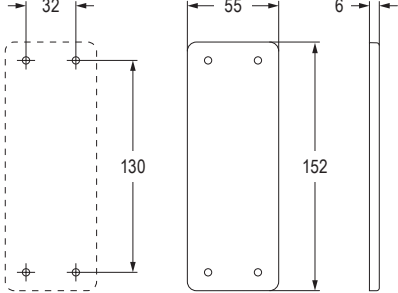

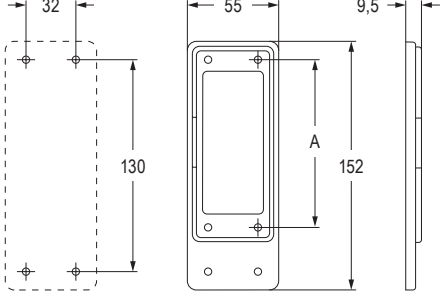
C.61, H.56



Tutorial

CRH/CRZ

Closure and reduction plates


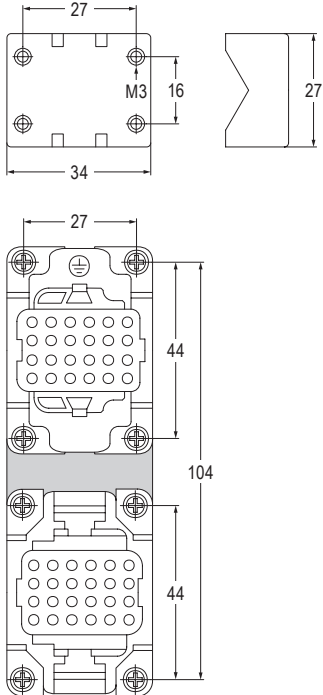
Item	Description	Part No.	Dimension										
	Closure plate, with gasket	CRH 24											
	Reduction plate, with gasket For 44.27 bulkhead mounting housings For 57.27 bulkhead mounting housings For 77.27 bulkhead mounting housings For 104.27 bulkhead mounting housings Cannot be used with T-TYPE and IP68 CG/MG series	CRZ 06 CRZ 10 CRZ 16 CRZ 24	 <table border="1"> <thead> <tr> <th>Part No.</th> <th>A (mm)</th> </tr> </thead> <tbody> <tr> <td>CRZ 06</td> <td>70</td> </tr> <tr> <td>CRZ 10</td> <td>83</td> </tr> <tr> <td>CRZ 16</td> <td>103</td> </tr> <tr> <td>CRZ 24</td> <td>130</td> </tr> </tbody> </table>	Part No.	A (mm)	CRZ 06	70	CRZ 10	83	CRZ 16	103	CRZ 24	130
Part No.	A (mm)												
CRZ 06	70												
CRZ 10	83												
CRZ 16	103												
CRZ 24	130												

Materials	
Closure/reduction plate	self-extinguishing thermoplastic resin
Gasket	vinyl-nitrile elastomer

Enclosures	Pages
Bulkhead mounting housings sizes 44.27, 57.27, 77.27 and 104.27	E.48-303
HNM Bulkhead mounting housings sizes 44.27, 57.27, 77.27 and 104.27	H.74-80

CBGF

Inserts joining block

Item	Description	Part No.	Dimension
	<p>Insert joining block, to mate two inserts</p> <p>Allows two 44.27 size inserts to be inserted in 104.27 size enclosures and on the following COB series items: COB TCQ, COB 24 BC, COB TSF, COB TSFS, COB 24 CMS</p> <p>Allows female inserts and male inserts in the same enclosure or mounting</p> <p>Allows mixed type inserts in the same enclosure or mounting (for example, 6 poles 16 A CNEF + 24 poles 10 A CDDF)</p>	<p>CBGF</p>	


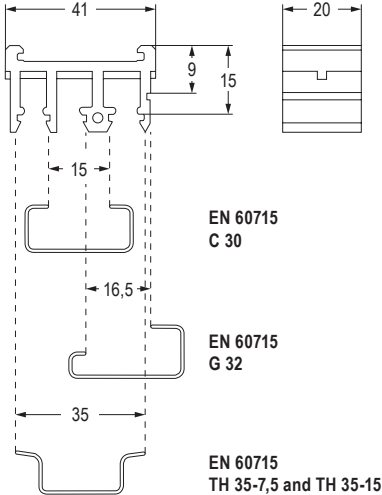

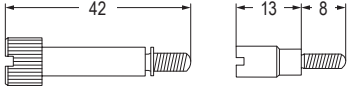

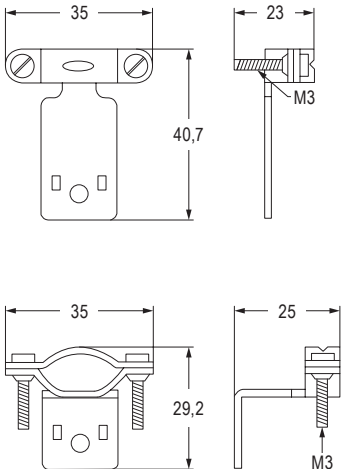
Materials	
Joining block	die-cast aluminium alloy

Inserts	Pages
Standard inserts, size 44.27	B.38-130
HNM inserts, size 44.27	H.10-26

Enclosures size 104.27	Pages
Metallic with C-TYPE lever	E.70-77
COB system for switch cabinet	E.286-289

CT/CRB/CRA






DIN rail mounting

Item	Description	Part No.	Dimension
	Support for rail mounting DIN EN 60715 for CT, CTS and CTSE inserts	CTAPE	
	M4 Screw pin for CD, CNE, CCE and CSH inserts M3 Bush for CT, CTS and CTSE inserts To guarantee a stable and safe coupling between inserts (without enclosures) with terminal blocks and inserts without terminal blocks.	CRBM CRBF	
	Straight cable clamping plate Angled cable clamping plate In accordance with the recommendations of standard IEC 60352-2, the weight of the conductor groups or multipolar cables must not cause any stress on the contacts inside the inserts. It is therefore advisable to use cable-clamping plates in those inserts without enclosures.	CRAD CRAS	

Inserts	Pages
CNE	B.38-43
CCE	B.44-49
CSH	B.52-57
CD	B.90-93
CT / CTSE, CT / CTS	B.126-135,138-141

CRIC / CR V..G

Screws

Item	Description	Part No.
	<p>Insert fastening screws, to be fitted instead of the current insert fastening screws</p> <p>The approved method of mounting insert is by fixing the four screws in an ILME enclosures</p>	CRIC M3
	<p>Screws for second protective PE For CDA, CDC, CSAH inserts</p>	CR VATG
	<p>Screws for second protective PE For CD 15-25, CDD 38 inserts</p>	CR VDTG
	<p>Screws for second protective PE For CD 40-64, CDD 24-42-72-108, CQE, CQEE, CNE, CSS, CX 8/24, CCE, CMSH, CME, CMCE, CSH, CDSH inserts</p>	CR VNTG
	<p>Screws for second protective PE For CP, CX 12/2, CX 6/36, CX 6/12, CX 4/0, CX 4/2 inserts</p>	CR VPTG

Inserts	Pages
Slim inserts, sizes 49.16 to 66.40	B.16-34
Standard inserts, sizes 44.27 to 104.62	B.38-171
HNM inserts, sizes 44.27 to 104.27	H.10-32
180 °C inserts, sizes 44.27 to 104.62	I.5-13

Special enclosures


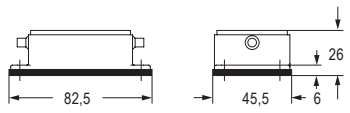
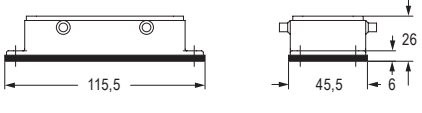
Bulkhead connectors

size **44.27 – 104.27**

Heavy-Duty Applications

EN 60529	-
UL 50 / UL 50E	Type 12 / 4 / 4X
Ambient temperature limits	-40 °C ... +125 °C
Mechanical life (cycles)	≥ 500

ECBT2.E115072 | ECBT8.E115072

Item	Description	Size	Part No.	Dimension
	Bulkhead mounting housings with 2 or 4 pegs 1) compatible only with V-Type lever and JEI® plastic lever enclosures 2) may be combined also with enclosures: - surface mounting housings - hoods with lever and gasket IP degrees are according to the type of lever of the counterpart enclosures. Panel cut-out drawings on page E.86.	44.27	CHI 06 LCH ¹⁾	 <p>CHI 06 LCH</p>
		57.27	CHI 10 CH ²⁾	
		77.27	CHI 16 CH ²⁾	 <p>CHI 16 CH</p>
		104.27	CHI 24 CH ²⁾	

Inserts	Pages
CNE	B.38-43
CCE	B.44-49
CSH / JSH S	B.52-63
CSHT	B.66-68
CQE / CQEE	B.72-79
CQEY	B.82-87
CD	B.90-93
CDD	B.94-99
CDSH	B.102-107
CP / CPY	B.112-115
CSS	B.118-123
CT / CTSE, CT / CTS	B.126-135,138-141
CMCE / CMSH	B.144-153
CX / CXC	B.156-171
Frames for modular units	C.95

Complete with:



Enclosures with levers and gasket
IL-BRID (Bulkhead, Surface, Hoods)
Pages E.90-103



Enclosures with levers and gasket
V-TYPE (Bulkhead, Surface, Hoods)
Pages E.124-127,129,131,133,135


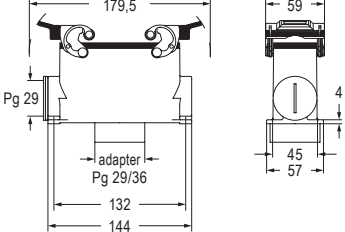
Special enclosures

Surface mounting with bottom entry

size **104.27**
**Heavy-Duty
Applications**


EN 60529	IP65 / IP66 / IP69
UL 50 / UL 50E	Type 12 / 4 / 4X
Ambient temperature limits	-40 °C ... +125 °C
Mechanical life (cycles)	≥ 500

CAVUS ECBT2.E115072 | ECBT8.E115072

Item	Description	Part No.	Entry	Dimension
	Surface mounting housings, 2 C-Type levers and gasket, high construction, bottom entry - With metal adapter: Pg 29 (hole), Pg 36 (thread)	CAP 24 G36	side: Pg 29 bottom: Pg 36	

Inserts size 104.27	Pages
CNE	B.41
CCE	B.47
CSH / JSH S	B.55,61
CSHT	B.68
CQE / CQEE	B.75,79
CQEY	B.85
CD	B.91
CDD	B.97
CDSH	B.105
CSS	B.121
CMCE / CMSH	B.146,151
CX / CXC	B.156-157,161-162
6-slot sized frames for modular units	C.95

Accessories:

CHCP 24
 Dust protection
 cover
 Page G.46

CR LCK
 Locking
 device
 Page G.43

Special enclosures


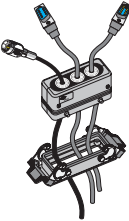
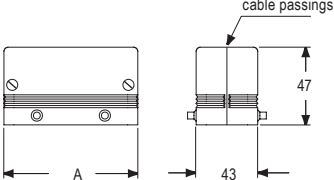
Cable passing hoods

size **77.27 – 104.27**

Heavy-Duty Applications

EN 60529	IP54
UL 50 / UL 50E	Type 12
Ambient temperature limits	-40 °C ... +125 °C
Mechanical life (cycles)	≥ 500

ECBT2.E115072 | ECBT8.E115072

Item	Description	Size.	Part No.	Entry	Dimension												
 	<p>Hoods, 4 pegs, without gasket, for cable passing</p> <p>The CYR enclosures are used in installations that require a passage for round cables for data transmission (e.g. computers or PLC) via equipment such as command or control panels, ensuring a good condition of the cable connections.</p> <p>The enclosures are in two parts and have sealing gaskets to preserve the degree of protection of the equipment. The enclosures also contain a rapid cable block device.</p> <p>The CYR 16.3 and 24.4 can be used with the bulkhead mounting housings with 2 levers respectively.</p>	<p>77.27</p> <p>104.27</p>	<p>CYR 16.3</p> <p>CYR 24.4</p>	<p>3 cables</p> <p>4 cables</p>	 <table border="1"> <thead> <tr> <th>Part No.</th> <th>A</th> <th>grommet entry</th> <th>nr.</th> </tr> </thead> <tbody> <tr> <td>CYR 16.3</td> <td>93,5</td> <td>ø 5 / 13,5</td> <td>3</td> </tr> <tr> <td>CYR 24.4</td> <td>120</td> <td>ø 5 / 13,5</td> <td>4</td> </tr> </tbody> </table>	Part No.	A	grommet entry	nr.	CYR 16.3	93,5	ø 5 / 13,5	3	CYR 24.4	120	ø 5 / 13,5	4
Part No.	A	grommet entry	nr.														
CYR 16.3	93,5	ø 5 / 13,5	3														
CYR 24.4	120	ø 5 / 13,5	4														

Enclosures size 77.27 and 104.27	Pages
Metallic with C-TYPE lever	E.64,72
Metallic with IL-BRID lever	E.98,102
Metallic with JEI®-P lever	E.116,118
Metallic with V-TYPE IP67 lever	E.126-127

Complete with:

 <p>Bulkhead enclosures C-TYPE Pages E.64,72</p>	 <p>Bulkhead enclosures IL-BRID Pages E.98,102</p>
 <p>Bulkhead enclosures JEI®-P Pages E.116,118</p>	 <p>Bulkhead enclosures V-TYPE Pages E.126-127</p>

Special enclosures

In-line joints

size **77.27**
**Heavy-Duty
Applications**


EN 60529	IP65
UL 50 / UL 50E	Type 12 / 4 / 4X
Ambient temperature limits	-40 °C ... +125 °C
Mechanical life (cycles)	≥ 500

ECBT2.E115072 | ECBT8.E115072

Item	Description	Part No.	Dimension
	<p>Enclosure for in-line joints, made in two halves</p> <p>CYG 16 in-line joint</p> <ul style="list-style-type: none"> - The joint is made with the CYG 16 enclosure and two bulkhead housings size 77.27 with one or two levers (to be ordered separately). - the joint is ideal for use with extension connections and/or as adapter. - made in two halves to facilitate conductor cabling. - two inserts in various combinations may be inserted in the joint (to be ordered separately): female/female inserts (as adapter joint), male/male inserts (as adapter joint) and female/male inserts (as extension joint) 	CYG 16	

Enclosures size 77.27	Pages
Metallic with C-TYPE lever	E.60,62,64
Metallic with IL-BRID lever	E.96,98
Metallic with JEI®-P lever	E.115-116
Metallic with V-TYPE IP67 lever	E.126,132
HNM - High Number of Matings	H.78

Complete with:

Bulkhead enclosures
C-TYPE
Pages E.60,62,64

Bulkhead enclosures
JEI®-P
Pages E.115-116

Bulkhead enclosures
HNM series
Pages H.78


Bulkhead enclosures
IL-BRID
Pages E.96,98

Bulkhead enclosures
V-TYPE
Pages E.126,132

Special enclosures – T-BOX


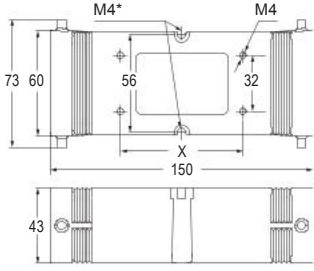

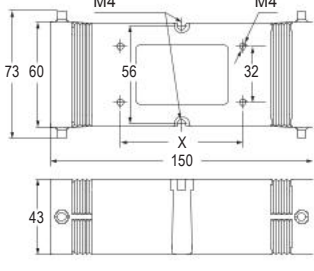
Branch coupling

size **44.27 – 57.27**

Heavy-Duty Applications 

EN 60529	IP66 / IP69
UL 50 / UL 50E	Type 12 / 4 / 4X
Ambient temperature limits	-40 °C ... +125 °C

 ECBT2.E115072 | ECBT8.E115072

Item	Description	Part No.	Dimension
	Branch-off T-BOX coupling for:	CYG 06H06	
	- 2 hoods with 1 lever and gasket size 44.27 on both sides - 1 bulkhead housing size 44.27 on front		
	Branch-off T-BOX coupling for:	CYG 06H10	
	- 2 hoods with 1 lever and gasket size 44.27 on both sides - 1 bulkhead housing size 57.27 on front		

Part No.	X
CYG 06H06	70
CYG 06H10	83

* M4 tap processing is required for proper attachment

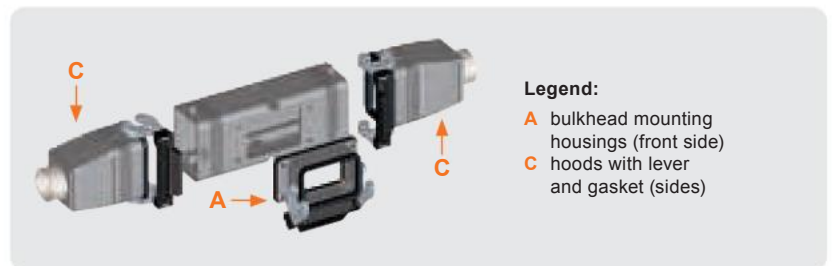
	Branch-off T-BOX coupling to be fitted in DIN rails for:	CYG 06H06D	
	- 2 hoods with 1 lever and gasket size 44.27 on both sides - 1 bulkhead housing size 44.27 on front		
	Branch-off T-BOX coupling to be fitted in DIN rails for:	CYG 06H10D	
	- 2 hoods with 1 lever and gasket size 44.27 on both sides - 1 bulkhead housing size 57.27 on front		

Part No.	X
CYG 06H06D	70
CYG 06H10D	83

ACCESSORIES

How to use the CYG 06H branch coupling:

- The cables are branched off by using the CYG 06H coupling in the 1 or 2 branch-off versions.
- Multi-pole inserts 44.27 size can be fitted inside the two side recesses.
- The entire unit can be used with one lever hoods complete with connector inserts.
- The front faces can be fitted with 44.27 and/or 57.27 size bulkhead housings.
- The coupling may also be used as an adapter by using a combination of different insert versions.
- The CHC 06 LG cover may be used to close the coupling side faces.
- In the branch-offs, the CSS series dual spring terminal inserts allow two wires to be connected without having to fit additional terminals inside the coupling.



Legend:

- A** bulkhead mounting housings (front side)
- C** hoods with lever and gasket (sides)

Complete with:

	Bulkhead enclosures		Hoods		Cover
	C-TYPE Pages E.48 E.54 E.56		C-TYPE Page E.48		C-TYPE Pages E.52
	IL-BRID Pages E.90 E.92 E.94		IL-BRID Page E.91		IL-BRID Pages E.90



Special enclosures – T-BOX


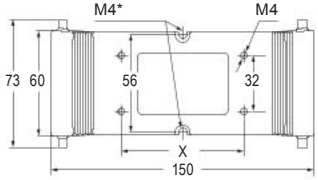

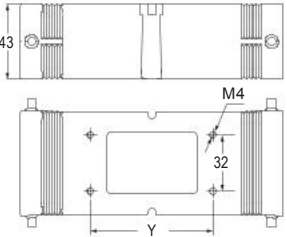
size **44.27 – 57.27**

Branch coupling

Heavy-Duty Applications


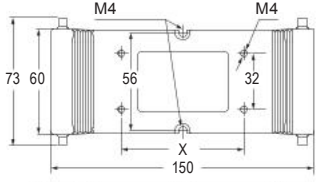

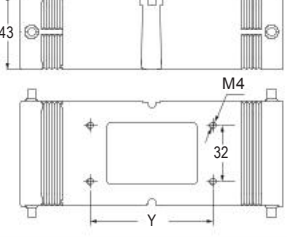
EN 60529	IP66 / IP69
UL 50 / UL 50E	Type 12 / 4 / 4X
Ambient temperature limits	-40 °C ... +125 °C

CALUS ECBT2.E115072 | ECBT8.E115072

Item	Description	Part No.	Dimension
	Branch-off T-BOX coupling for:	CYG 06H0610	
	- 2 hoods with 1 lever and gasket size 44.27 on both sides - 1 bulkhead housing size 44.27 on front - 1 bulkhead housing size 57.27 on screw fixing rear		
	Branch-off T-BOX coupling for:	CYG 06H1006	
	- 2 hoods with 1 lever and gasket size 44.27 on both sides - 1 bulkhead housing size 57.27 on front - 1 bulkhead housing size 44.27 on screw fixing rear		

Part No.	X	Y
CYG 06H0610	70	83
CYG 06H1006	83	70

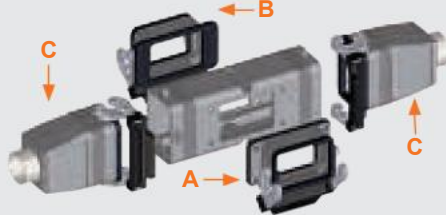
* M4 tap processing is required for proper attachment

	Branch-off T-BOX coupling for:	CYG 06H0606	
	- 2 hoods with 1 lever and gasket size 44.27 on both sides - 1 bulkhead housing size 44.27 on front - 1 bulkhead housing size 44.27 on screw fixing rear		
	Branch-off T-BOX coupling for:	CYG 06H1010	
	- 2 hoods with 1 lever and gasket size 44.27 on both sides - 1 bulkhead housing size 57.27 on front - 1 bulkhead housing size 57.27 on screw fixing rear		

Part No.	X	Y
CYG 06H0606	70	70
CYG 06H1010	83	83







How to use the CYG 06H branch coupling:

- The cables are branched off by using the CYG 06H coupling in the 1 or 2 branch-off versions.
- Multi-pole inserts 44.27 size can be fitted inside the two side recesses.
- The entire unit can be used with one lever hoods complete with connector inserts.
- The front faces can be fitted with 44.27 and/or 57.27 size bulkhead housings.
- The coupling may also be used as an adapter by using a combination of different insert versions.
- The CHC 06 LG cover may be used to close the coupling side faces.
- In the branch-offs, the CSS series dual spring terminal inserts allow two wires to be connected without having to fit additional terminals inside the coupling.



Legend:

- A** bulkhead mounting housings (front side)
- B** bulkhead mounting housings (screw fixing rear)
- C** hoods with lever and gasket (sides)

	Bulkhead enclosures C-TYPE Pages E.48 , E.54 , E.56		Hoods C-TYPE Page E.48		Cover C-TYPE Pages E.52
	IL-BRID Pages E.90 , E.92 , E.94		IL-BRID Page E.91		IL-BRID Pages E.90

Special Enclosures – T-BOX

size **21.21**

T-junction for 21.21 inserts

Heavy-Duty Applications



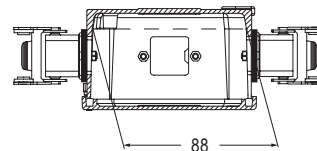
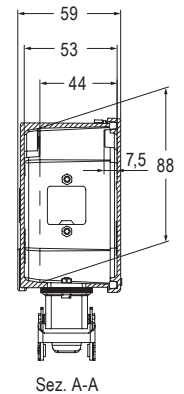
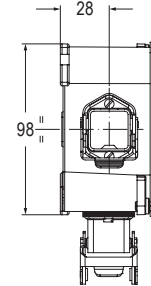
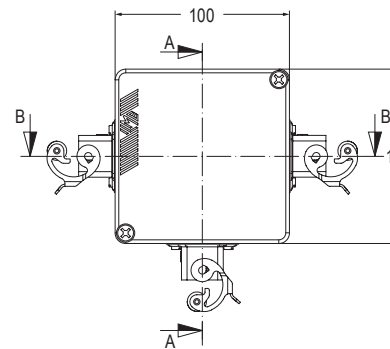
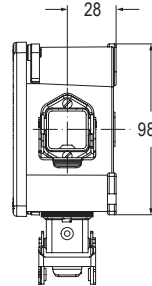
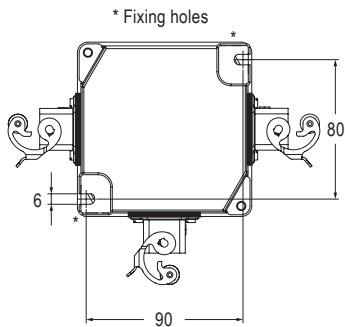
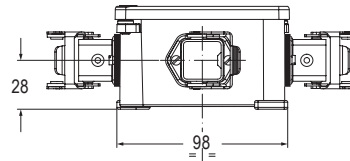
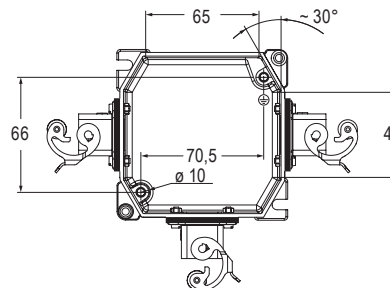
EN 60529	IP44
With CKR 65	IP66 / IP67
UL 50 / UL 50E	Type 12 / 4 / 4X
Ambient temperature limits	-40 °C ... +110 °C
Mechanical life (cycles)	≥ 500

Item	Description	Part No.	Dimension
------	-------------	----------	-----------



T-junction box with 3 CKAX 03 I housings pre-assembled

CYG 9KAXI3

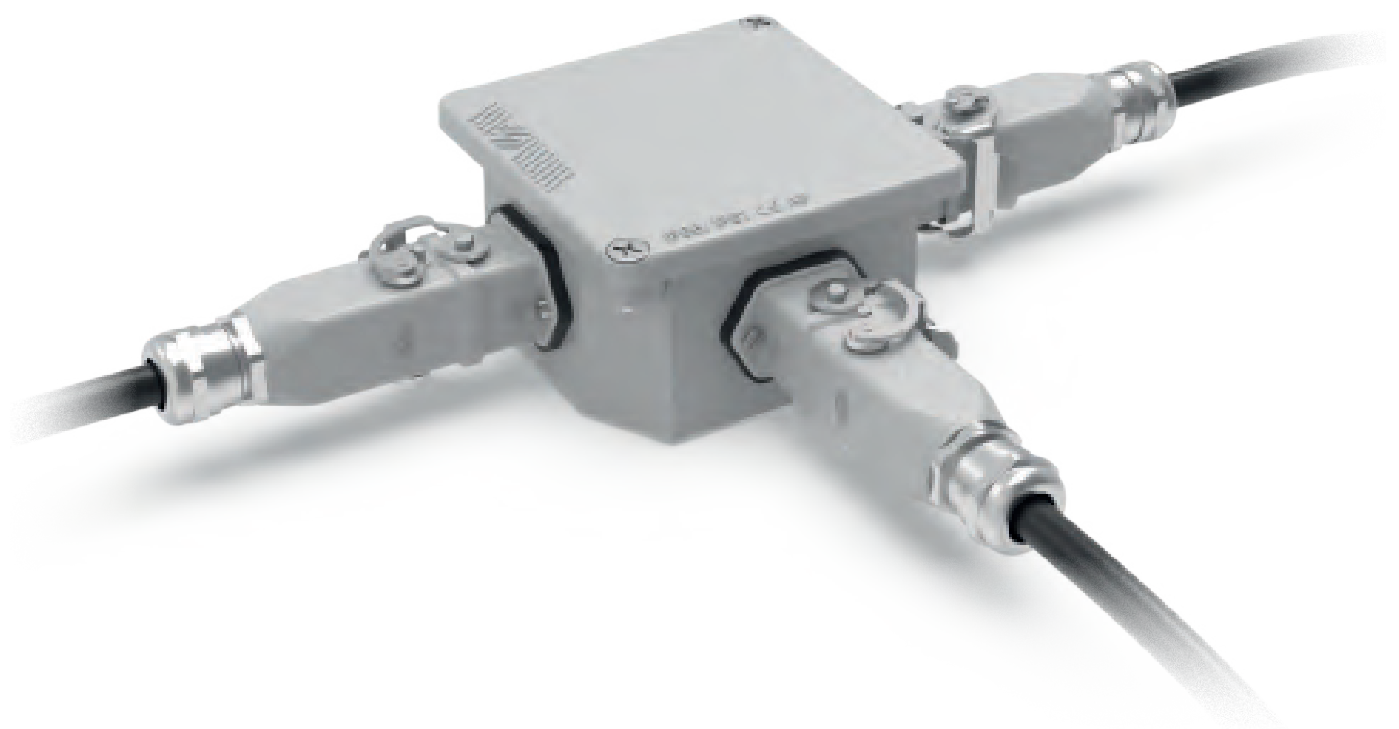


Compact 21.21 Inserts	Pages
CQ4 / CQ / CQY	A.4-12
CK / CKSH	A.16-19
CD / CDY	A.22-25
Data inserts	A.30-38

Complete with:


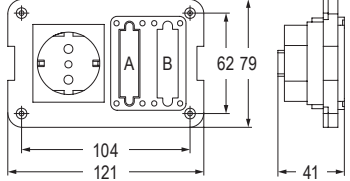

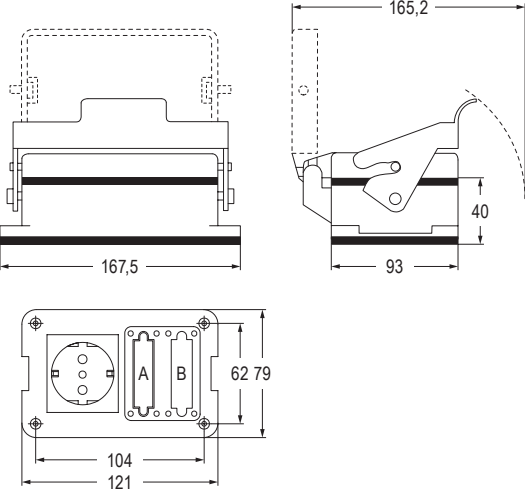


Hoods
21.21 enclosures
Pages A.64,66



SDS / CHSDS

Kit for control equipment


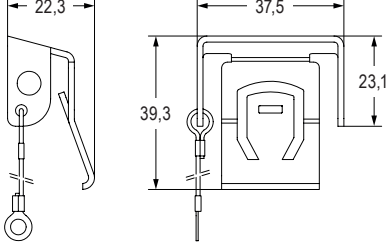

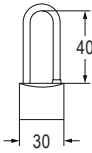
Item	Description	Part No.	Dimension
	<p>Kit for control equipment plate only With Shuko® socket 16 A and 2 seats for CR 09/15/25 AD plates</p> <p>Closed seat "A" for use with one insert only. The closings achieved by means of a plastic membrane that can easily be removed if the second seat is required.</p>	<p>SDS</p>	
	<p>Kit for control equipment plate with CHI 48 LS enclosure With Shuko® socket 16 A and 2 seats for CR 09/15/25 AD plates</p> <p>Closed seat "A" for use with one insert only. The closings achieved by means of a plastic membrane that can easily be removed if the second seat is required.</p>	<p>CHSDS</p>	

ACCESSORIES
G

Enclosures size 104.62	Pages
CHI 48 LS	E.84
CHIW 48 LS	E.168
CHIE 48 LS	E.192

CR CLK


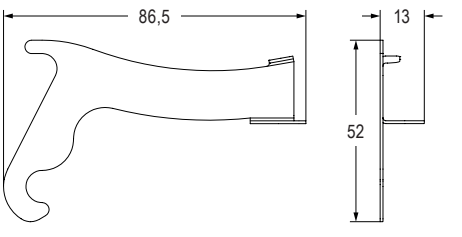

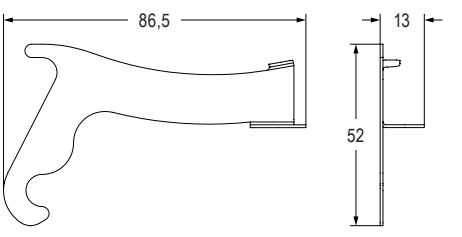


Locking devices for CLASS series

Item	Description	Part No.	Dimension
	<p>Stainless steel locking device for two-lever housings With eyelet for fixing on housings</p> <p>Cannot be used with hoods with locking levers and gasket, and high construction surface mounting housing.</p>	CR CLK	
	<p>Padlock, supplied with 2 keys</p>	TM BLC125	

Enclosures size 57.27, 77.27 and 104.27	Pages
CHI	E.56,64,72
MHP / CHP	E.56,64,72
MAP / CAP	E.56,64,72

CR YLK

Locking devices for CENTRAL LEVER series

Item	Description	Part No.	Dimension
	Stainless steel locking device for size 104.27 enclosures with central lever To be mounted on housings	CR YLK24	
	Stainless steel locking device for size 104.27 enclosures with central lever To be mounted on hoods	CR YLK24 SL	
	Padlock, supplied with 2 keys	CR BLC622	

ACCESSORIES


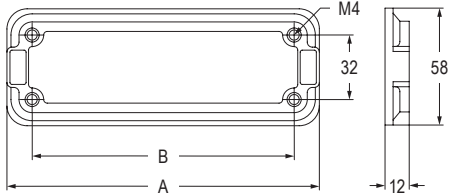

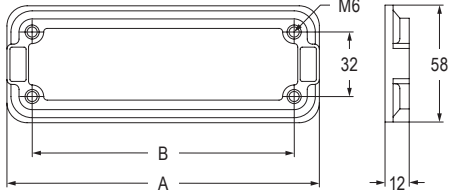
G

Enclosures size 104.27	Pages
Standard applications with Central lever	E.261



C7..FL/CG..FL


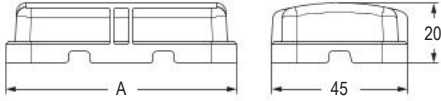

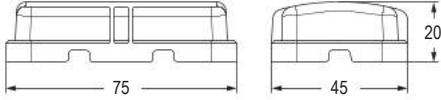
Counterflanges for V-TYPE and IP68 series

Item	Description	Part No.	Dimension															
	Counterflanges for V-TYPE IP67 bulkhead mounting housings Size 44.27 Size 57.27 Size 77.27 Size 104.27	C7 06 FL C7 10 FL C7 16 FL C7 24 FL	 <table border="1"> <thead> <tr> <th>Part No.</th> <th>A (mm)</th> <th>B (mm)</th> </tr> </thead> <tbody> <tr> <td>C7 06 FL</td> <td>96</td> <td>70</td> </tr> <tr> <td>C7 10 FL</td> <td>109</td> <td>83</td> </tr> <tr> <td>C7 16 FL</td> <td>128</td> <td>103</td> </tr> <tr> <td>C7 24 FL</td> <td>155</td> <td>130</td> </tr> </tbody> </table>	Part No.	A (mm)	B (mm)	C7 06 FL	96	70	C7 10 FL	109	83	C7 16 FL	128	103	C7 24 FL	155	130
Part No.	A (mm)	B (mm)																
C7 06 FL	96	70																
C7 10 FL	109	83																
C7 16 FL	128	103																
C7 24 FL	155	130																
	Counterflanges for IP68 bulkhead mounting housings Size 44.27 Size 57.27 Size 77.27 Size 104.27	CG 06 FL CG 10 FL CG 16 FL CG 24 FL	 <table border="1"> <thead> <tr> <th>Part No.</th> <th>A (mm)</th> <th>B (mm)</th> </tr> </thead> <tbody> <tr> <td>CG 06 FL</td> <td>96</td> <td>70</td> </tr> <tr> <td>CG 10 FL</td> <td>109</td> <td>83</td> </tr> <tr> <td>CG 16 FL</td> <td>129</td> <td>103</td> </tr> <tr> <td>CG 24 FL</td> <td>156</td> <td>130</td> </tr> </tbody> </table>	Part No.	A (mm)	B (mm)	CG 06 FL	96	70	CG 10 FL	109	83	CG 16 FL	129	103	CG 24 FL	156	130
Part No.	A (mm)	B (mm)																
CG 06 FL	96	70																
CG 10 FL	109	83																
CG 16 FL	129	103																
CG 24 FL	156	130																

Enclosures size 44.27, 57.27, 77.27 and 104.27	Pages
C7..FL	
C7I	E.124-127
CG..FL	
CGI	E.142-149
C7IW	E.154,156,158,160
C7IE	E.174,176,178,180
CGIE	E.194-197

CHCP


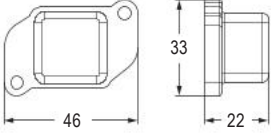

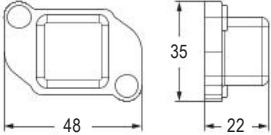

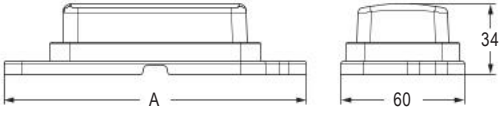

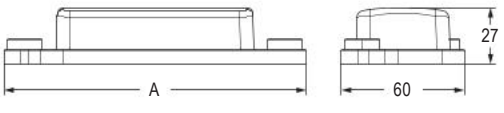
Temporary protection cover

Item	Description	Part No.	Dimension										
	Dust protection cover for housings and hoods, with 1-2 levers, 2-4 pegs Size 44.27 Size 57.27 Size 77.27 Size 104.27 Possibility of using cable ties to increase the retention of the insulating cover on the hood Cannot be used with T-TYPE, IP68 and COB series	CHCP 06 CHCP 10 CHCP 16 CHCP 24	 <table border="1"> <thead> <tr> <th>Part No.</th> <th>A (mm)</th> </tr> </thead> <tbody> <tr> <td>CHCP 06</td> <td>62</td> </tr> <tr> <td>CHCP 10</td> <td>75</td> </tr> <tr> <td>CHCP 16</td> <td>96</td> </tr> <tr> <td>CHCP 24</td> <td>122</td> </tr> </tbody> </table>	Part No.	A (mm)	CHCP 06	62	CHCP 10	75	CHCP 16	96	CHCP 24	122
Part No.	A (mm)												
CHCP 06	62												
CHCP 10	75												
CHCP 16	96												
CHCP 24	122												
	Painting protection cover for housings and hoods, with 1-2 levers, 2-4 pegs Size 57.27 For housings and hoods with gasket only Cannot be used with T-TYPE, IP68 and COB series	CHCP 10 V											

Enclosures size 44.27, 57.27, 77.27 and 104.27	Pages
Metallic with C-TYPE lever	E.48-77
Metallic with IL-BRID lever	E.90-107
Metallic with JEI®-P lever	E.112-119
Metallic with V-TYPE IP67 lever	E.124-135
Metallic W-TYPE	E.154-165
Metallic E-Xtreme®	E.174-189
EMC (Electromagnetic Shielding)	E.208-219
Standard applications with Central lever	E.254-261
BIG Enclosures for multiple cable entries	E.268-279
Light and Sound applications with JEI®-P lever	E.296-303
HNM - High Number of Matings	E.174-81
180 °C High Temperatures	E.18-25

CGKCP / CGCP


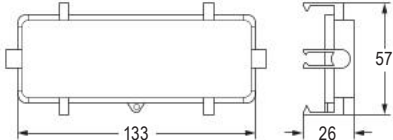
Temporary protection cover

Item	Description	Part No.	Dimension										
	Dust protection cover for IP68 housings Size 21.21 Possibility to fix by 2×M3 screws	CGKCP FX											
	Dust protection cover for IP68 hoods Size 21.21 Possibility of using cable ties to increase the retention of the insulating cover on the hood	CGKCP MB											
	Dust protection cover for IP68 housings Size 44.27 Size 57.27 Size 77.27 Size 104.27 Possibility to fix by 2×M6 screws	CGCP 06 FX CGCP 10 FX CGCP 16 FX CGCP 24 FX	 <table border="1"> <thead> <tr> <th>Part No.</th> <th>A (mm)</th> </tr> </thead> <tbody> <tr> <td>CGCP 06 FX</td> <td>134</td> </tr> <tr> <td>CGCP 10 FX</td> <td>148</td> </tr> <tr> <td>CGCP 16 FX</td> <td>168</td> </tr> <tr> <td>CGCP 24 FX</td> <td>195</td> </tr> </tbody> </table>	Part No.	A (mm)	CGCP 06 FX	134	CGCP 10 FX	148	CGCP 16 FX	168	CGCP 24 FX	195
Part No.	A (mm)												
CGCP 06 FX	134												
CGCP 10 FX	148												
CGCP 16 FX	168												
CGCP 24 FX	195												
	Dust protection cover for IP68 hoods Size 44.27 Size 57.27 Size 77.27 Size 104.27 Possibility of using cable ties to increase the retention of the insulating cover on the hood	CGCP 06 MB CGCP 10 MB CGCP 16 MB CGCP 24 MB	 <table border="1"> <thead> <tr> <th>Part No.</th> <th>A (mm)</th> </tr> </thead> <tbody> <tr> <td>CGCP 06 MB</td> <td>134</td> </tr> <tr> <td>CGCP 10 MB</td> <td>148</td> </tr> <tr> <td>CGCP 16 MB</td> <td>168</td> </tr> <tr> <td>CGCP 24 MB</td> <td>195</td> </tr> </tbody> </table>	Part No.	A (mm)	CGCP 06 MB	134	CGCP 10 MB	148	CGCP 16 MB	168	CGCP 24 MB	195
Part No.	A (mm)												
CGCP 06 MB	134												
CGCP 10 MB	148												
CGCP 16 MB	168												
CGCP 24 MB	195												

Enclosures	Pages
Metallic IP68 high protection, screw locking size 21.21	A.78 80
Metallic IP68 high protection, screw locking size 44.27, 57.27, 77.27 and 104.27	E.142 144 146 148
Metallic E-Xtreme® IP68, screw locking size 44.27, 57.27, 77.27 and 104.27	E.194-197

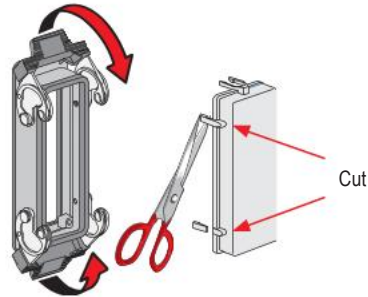
CPT

Temporary protection cover

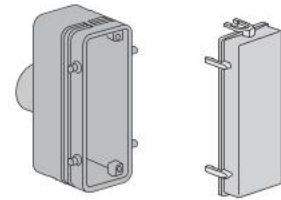
Item	Description	Part No.	Dimension
	Temporary protection cover for 104.27 housings and hoods, with 1-2 levers and 2-4 pegs Cannot be used with T-TYPE, IP68 and COB series	CPT 24	

Guidances for enclosures

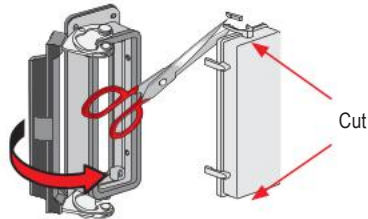
with 2 levers



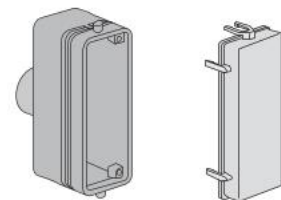
with 4 pegs



with 1 lever




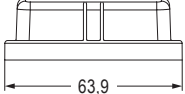
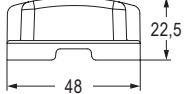
with 2 pegs



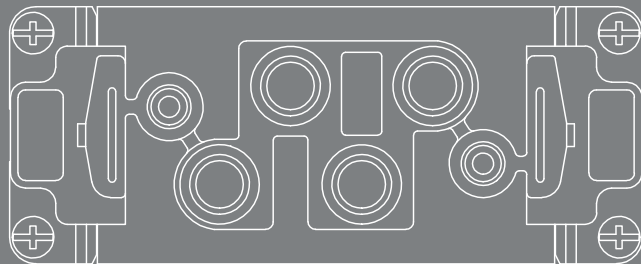
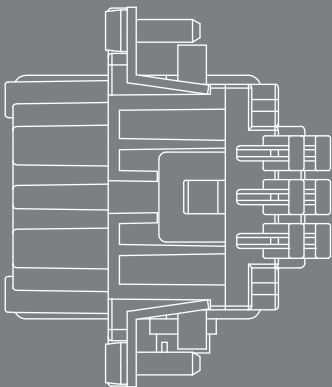
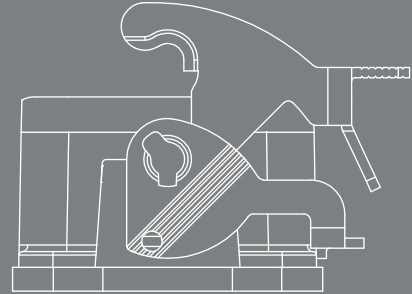
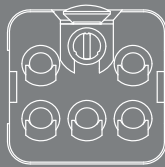
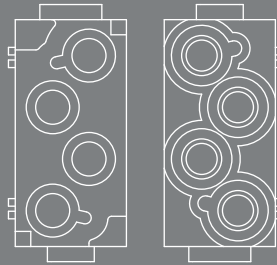
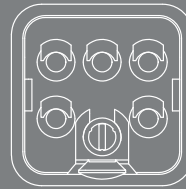
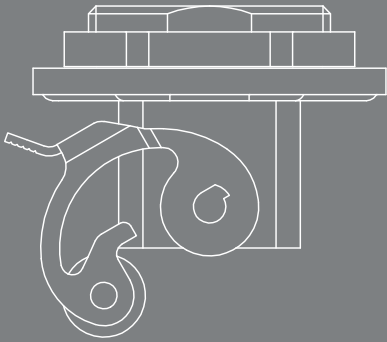
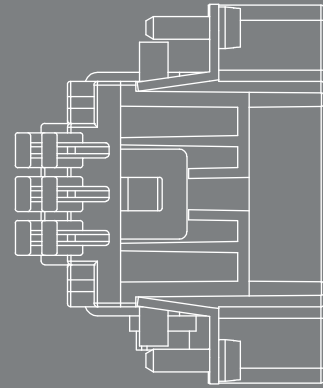
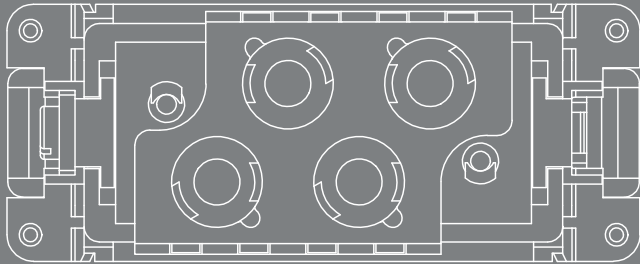
Enclosures size 104.27	Pages
Metallic with C-TYPE lever	E.70-77
Metallic with IL-BRID lever	E.100-103 107
Metallic with JEI®-P lever	E.117-118
Metallic with V-TYPE IP67 lever	E.127 134-135
Metallic W-TYPE	E.160-161 165
Metallic E-Xtreme®	E.180-181 188-189
EMC (Electromagnetic Shielding)	E.214-215 219
Standard applications with Central lever	E.260-261
BIG Enclosures for multiple cable entries	E.271 278-279
Light and Sound applications with JEI®-P lever	E.302-303
HNM - High Number of Matings	1.80-81
180 °C High Temperatures	.24-25

TCP

Temporary protection cover for T-TYPE series

Item	Description	Part No.	Dimension	
	<p>Disposable polypropylene dust protection cover for T-TYPE size 44.27 hoods</p> <p>Special ribs for fastening with cable tie (not provided)</p>	TCP 06		







Enclosures size 44.27	Pages
Thermoplastic T-TYPE	E.226-227
Thermoplastic T-TYPE/W	E.226-227
Hygienic series for food and beverage	E.244

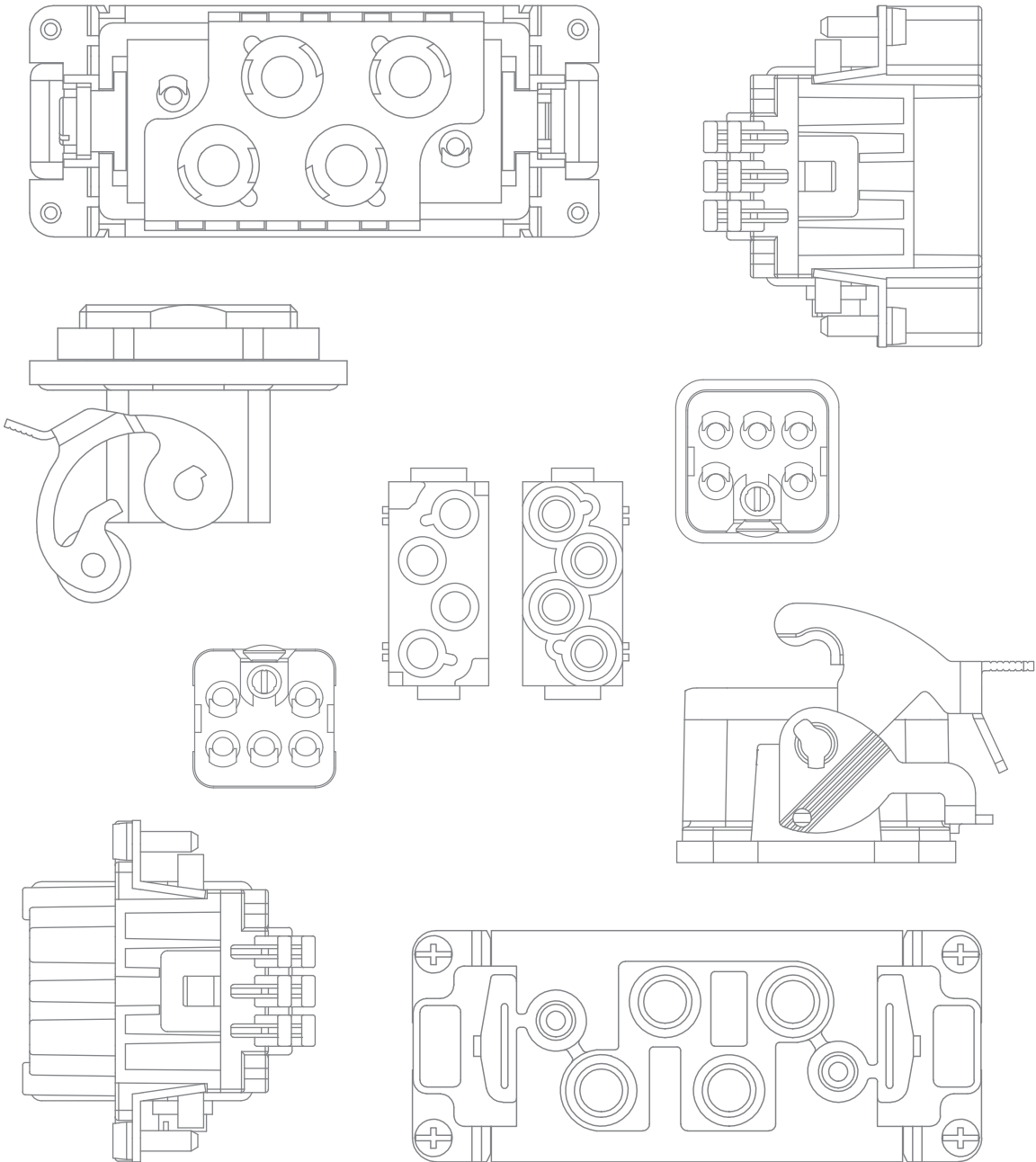


GENERAL CATALOGUE

HNM - High Number of Mating cycles connectors series

Contents






Inserts		H.4
21.21 inserts	Compact size 21.21 CQ4 / RQ / CQ HNM series	
	- 40 A crimp	H.6
	- 16 A crimp	H.7
	- 6,5 A crimp	H.8
	CD HNM series	
	- 10 A crimp	H.9
Standard inserts	Size 44.27, 57.27, 77.27 and 104.27	
	RCE series	
	- 16 A crimp	H.10-13
	RSH series	
	- 16 A tool-less - SQUICH®	H.14-17
	RQEE series	
	- 16 A crimp	H.18-19
	RD series	
	- 10 A crimp	H.20-21
	RDD series	
	- 10 A crimp	H.22-25
	RDSH series	
	- 10 A tool-less - SQUICH®	H.26-29
Combined inserts	Size 77.27 and 104.27	
	RXC / RX series	
	- 80 A crimp	H.30-31
	- 40 A crimp	H.32



GENERAL CATALOGUE

HNM - High Number of Mating cycles connectors series

Contents

MIXO modular inserts		<i>H.34</i>
Modules	Power & Signal	
	- 70 A crimp	H.38
	- 40 A crimp	H.39-43
	- 16 A crimp	H.44-47
	- 10 A crimp	H.48-50
	- 4 A crimp	H.51-52
	Shielded	
	- 10 A crimp	H.53
	- 5 A crimp	H.54
	- 4 A crimp	H.55
	Pneumatic	
	- Metal	H.58-61
MIXO frames & accessories		
	- MIXO frames	H.62
	- CGT PE terminal adapters	H.63
	- Stainless-steel self-centring floating frames	H.64
	- MIXO thermoplastic docking frames	H.65-68
	- Dummy modules	H.69
Enclosures		<i>H.70</i>
	Compact size 21.21	H.72-73
	Size 44.27, 54.27, 77.27 and 104.27	H.74-81

HNM

inserts



Specifically designed for applications requiring a high number of mating cycles, the HNM product range guarantees up to 10 000 matings for standard-size inserts (44.27, 57.27, 77.27 and 104.27) and up to 5 000 for compact 21.21 size inserts.

The connector inserts are ideal for frequent disconnection applications: test benches, charging systems, and removable tooling equipment.

Product Range

Compact 21.21 size


- > **CQ4F / M 03** inserts with 40 A HNM crimp contacts, RX series
- > **RQF / M 05** inserts with 16 A HNM crimp contacts, RC series
- > **RDF** inserts with 10 A HNM crimp contacts, RD series
- > **CQF** inserts with 5 A HNM crimp contacts, RI series

Standard 44.27, 57.27, 77.27 and 104.27 size

- > **RCE** inserts with 16 A HNM crimp contacts, RC series
- > **RSH** inserts with 16 A tool-less - SQUICH® termination technology
- > **RQE / RQEE** inserts with 16 A HNM crimp contacts, RC series
- > **RD / RDD** inserts with 10 A HNM crimp contacts, RD series
- > **RDSH** inserts with 10 A tool-less - SQUICH® termination technology

Combined 77.27 and 104.27 size

- > **RX** inserts with 40 A HNM crimp contacts series RX
- > **RXC** inserts with 80 A HNM crimp contacts series RX7

 **NOTE:** For contacts in the HNM version (series RI, RD, RC, RX and RX7), the same tools are suitable for crimping, insertion/extraction (where indicated) as those used for the corresponding contacts in the standard version (respectively series CI, CD, CC, CX and CX7).

FOCUS

HNM treatment

The HNM treatment applied to the standard and combined crimp, screw and tool-less inserts (lubrication of the PE plates and HNM contacts) extends the mechanical life of each connector from 500 to 10 000 mating cycles when used in combination with dedicated HNM enclosures, ensuring optimal performance and reducing the connection progressive deterioration.

Suitable HNM inserts are available for the whole product range, identified where needed by the "HNM" identifier acronym.



CQ4 03 HNM (High Number of Mating cycles)

40 A 400 V

size **21.21**

3 poles + ⊕

Crimp connection


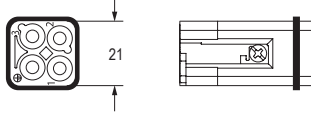

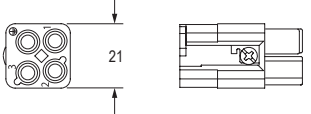
EN 61984 rating	40 A 400 V 6 kV 3
Rated voltage (UL / CSA)	600 V
Insulation resistance	≥ 10 GΩ
Contact resistance	≤ 0,3 mΩ
Ambient temperature limit	-40 °C ... +125 °C
Mechanical life (cycles)	≥ 5 000

CE UK EAC

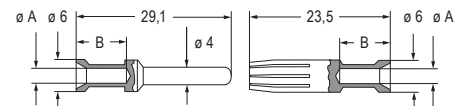
DNV (pending: CQC)

CAIUS

ECBT2.E115072 | ECBT8.E115072
PVVA2.E506437 | PVVA8.E506437

Item	Description	Part No.	Dimension
	Male inserts for male contacts Without contacts (to be ordered separately) Male insert is protected from access with the back of the hand (IP1X or IPXXA)	CQ4M 03	
	Female inserts for female contacts Without contacts (to be ordered separately) Female insert is finger proof (IP2X or IPXXB) even if not coupled	CQ4F 03	

40 A HNM crimp contacts	section (mm ²)		section (AWG)		Male	Female
		1,5	2,5	16	14	
	4	6	12	10		
	10		8			
					gold	
					RXM2D 1.5	RXF2D 1.5
					RXM2D 2.5	RXF2D 2.5
					RXM2D 4.0	RXF2D 4.0
					RXM2D 6.0	RXF2D 6.0
					RXM2D 10	RXF2D 10



Wiring information, RX contacts

conductor section (mm ²)	conductor slot \varnothing A (mm)	stripping length B (mm)
1,5	1,8	9
2,5	2,2	9
4	2,85	9,6
6	3,5	9,6
10	4,3	15

Wire diameter: up to 7 mm.

It is recommended to use the crimping tools and removal tools homologated by ILME (please see page F.23)

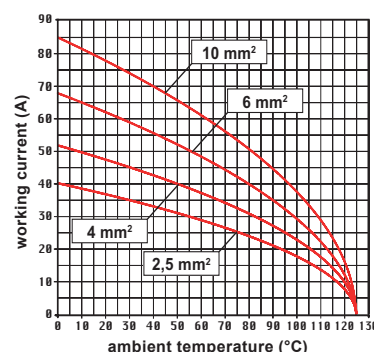
Materials

Insert	polycarbonate (PC)
UL 94 flame rating	V-0
Colour	pebble grey, RAL 7032
Contacts	copper alloy, gold ● plated (HNM version)



CR Q03
Coding pins
Page G.6

Compact 21.21 enclosures	Pages
Specialized Applications	
HNM High Number of Mating cycles	H.72-73



CQ4 03 inserts max. current load derating diagram



RQ 05 HNM (High Number of Mating cycles)

16 A 230/400 V

size **21.21**

5 poles + ⊕


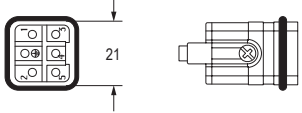
Crimp connection

EN 61984 rating	16 A 230 / 400 V 4 kV 3
	16 A 320 / 500 V 4 kV 2
Rated voltage (UL / CSA)	600 V
Insulation resistance	≥ 10 GΩ
Contact resistance	≤ 1 mΩ
Ambient temperature limit	-40 °C ... +125 °C
Mechanical life (cycles)	≥ 5 000

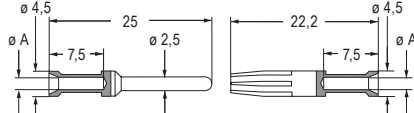


DNV VERITAS (pending: CQC)

CEC® ECBT2.E115072 | ECBT8.E115072

Item	Description	Part No.	Dimension
	Male inserts for male contacts Without contacts, including PE (to be ordered separately) PE screw connection for unprepared wires only	RQM 05	

	Female inserts for female contacts Without contacts, including PE (to be ordered separately) PE screw connection for unprepared wires only	RQF 05	
--	---	------------------------	---

16 A HNM crimp contacts	section (mm ²)		Male	Female	
	0,14-0,37	26-22			
0,5	20		RCM2D 0.3	RCF2D 0.3	
0,75	18		RCM2D 0.5	RCF2D 0.5	
1	18		RCM2D 0.7	RCF2D 0.7	
1,5	16		RCM2D 1.0	RCF2D 1.0	
2,5	14		RCM2D 1.5	RCF2D 1.5	
3	12		RCM2D 2.5	RCF2D 2.5	
4	12		RCM2D 3.0	RCF2D 3.0	
			RCM2D 4.0	RCF2D 4.0	

Wiring information, RC contacts

conductor section (mm ²)	conductor slot ø A (mm)	stripping length (mm)
0,14-0,37	0,9	7,5
0,5	1,1	7,5
0,75	1,3	7,5
1,0	1,45	7,5
1,5	1,8	7,5
2,5	2,2	7,5
3,0	2,55	7,5
4,0	2,85	7,5

Wire diameter: up to 4,7 mm.

It is recommended to use the crimping tools and removal tools homologated by ILME (please see page F.23)

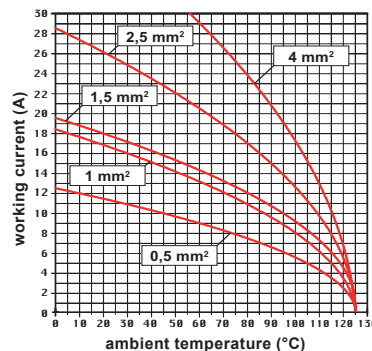
Materials

Insert	polycarbonate (PC)
UL 94 flame rating	V-0
Colour	pebble grey, RAL 7032
Contacts	copper alloy, gold ● plated (HNM version)



CR CPQ
Coding pins
Page G.3

Compact 21.21 enclosures	Pages
Specialized Applications	
HNM High Number of Mating cycles	H.72-73



RQ 05 inserts max. current load derating diagram

Can also be used partially fitted with 4 mm² section contacts

CQ 21 HNM (High Number of Mating cycles)

6,5 A 50 V_{AC} / 120 V_{DC}

size **21.21**
21 poles + ⊕

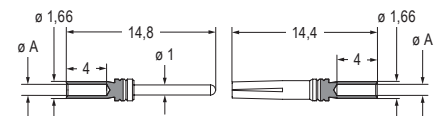
Crimp connection

EN 61984 rating	6,5 A 50 V _{AC} / 120 V _{DC} 0,8 kV 3
Rated voltage (UL / CSA)	250 V
Insulation resistance	≥ 10 GΩ
Contact resistance	≤ 4 mΩ
Ambient temperature limit	-40 °C ... +125 °C
Mechanical life (cycles)	≥ 5 000

(pending: CQC)

ECBT2.E115072 | ECBT8.E115072

Item	Description	Part No.	Dimension
	Male inserts for male contacts Without contacts (to be ordered separately) Seat of contact #9 set forward to obtain pre-leading contact	CQM 21	
	Female inserts for female contacts Without contacts (to be ordered separately) Seat of contact #9 set forward to obtain pre-leading contact	CQF 21	
	5 A HNM crimp contacts section (mm ²) section (AWG)	Male gold RIMD 0.2 RIMD 0.3 RIMD 0.5	Female RIFD 0.2 RIFD 0.3 RIFD 0.5



Wiring information, RI contacts

conductor section (mm ²)	conductor slot ϕA (mm)	stripping length (mm)
0,08-0,21	0,64	4
0,13-0,33	0,9	4
0,33-0,52	1,12	4

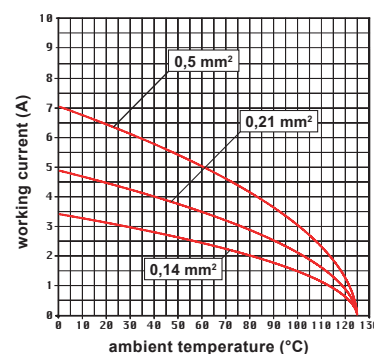
Wire diameter: up to 1,7 mm.

It is recommended to use the crimping tools and removal tools homologated by ILME (please see page F.23)

Materials

Insert	polycarbonate (PC)
UL 94 flame rating	V-0
Colour	pebble grey, RAL 7032
Contacts	copper alloy, gold plated (HNM version)

Compact 21.21 enclosures	Pages
Specialized Applications	
HNM High Number of Mating cycles	H.72-73



CQ 21 inserts max. current load derating diagram

CD 08 HNM (High Number of Mating cycles)

10 A 50 V_{AC} / 120 V_{DC}

size **21.21**

8 poles

Crimp connection

EN 61984 rating	10 A 50 V _{AC} / 120 V _{DC} 0,8 kV 3
Rated voltage (UL / CSA)	50 V _{AC} / 120 V _{DC}
Insulation resistance	≥ 10 GΩ
Contact resistance	≤ 3 mΩ
Ambient temperature limit	-40 °C ... +125 °C
Mechanical life (cycles)	≥ 5 000

(pending: CQC)

ECBT2.E115072 | ECBT8.E115072

Item	Description	Part No.	Dimension
	Male inserts for male contacts Without contacts (to be ordered separately)	CDM 08	
	Female inserts for female contacts Without contacts (to be ordered separately) Can be mounted into the straight bulkhead housings CK 1 from the rear	CDF 08	

	10 A HNM crimp contacts		Male	Female	
	section (mm ²)	section (AWG)			
	0,14-0,37	26-22	RDM2D 0.3	RDF2D 0.3	
	0,5	20	RDM2D 0.5	RDF2D 0.5	
	0,75	18	RDM2D 0.7	RDF2D 0.7	
	1	18	RDM2D 1.0	RDF2D 1.0	
	1,5	16	RDM2D 1.5	RDF2D 1.5	
	2,5	14	RDM2D 2.5	RDF2D 2.5	

Wiring information, RD contacts

conductor section (mm ²)	conductor slot ø A (mm)	stripping length B (mm)
0,14-0,37	0,9	8
0,5	1,1	8
0,75	1,3	8
1,0	1,45	8
1,5	1,8	8
2,5	2,2	6

Wire diameter: up to 3,8 mm.

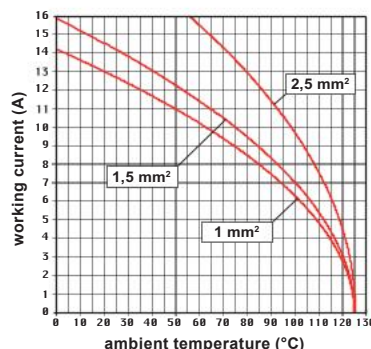
It is recommended to use the crimping tools and removal tools homologated by ILME (please see page [F.23](#))

Materials

Insert	polycarbonate (PC)
UL 94 flame rating	V-0
Colour	pebble grey, RAL 7032
Contacts	copper alloy, gold plated (HNM version)

CR CP
Coding pins
Page [G.3](#)

Compact 21.21 enclosures	Pages
Specialized Applications	
HNM High Number of Mating cycles	1.72-73



CD 08 inserts max. current load derating diagram

RCE 06 HNM (High Number of Mating cycles)

16 A 500 V

size **44.27**


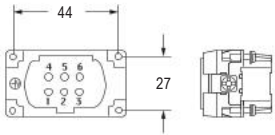

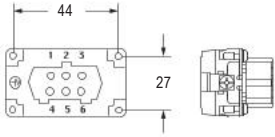
6 poles + ⊕

Crimp connection

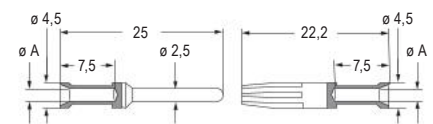
EN 61984 rating	16 A 500 V 6 kV 3
	16 A 400 / 690 V 6 kV 2
Rated voltage (UL / CSA)	600 V
Insulation resistance	≥ 10 GΩ
Contact resistance	≤ 1 mΩ
Ambient temperature limit	-40 °C ... +125 °C
Mechanical life (cycles)	≥ 10 000



CAIUS ECBT2.E115072 | ECBT8.E115072

Item	Description	Part No.	Dimension
	Male inserts for male contacts Without contacts (to be ordered separately)	RCEM 06	
	Female inserts for female contacts Without contacts (to be ordered separately)	RCEF 06	

16 A HNM crimp contacts	section (mm ²)		section (AWG)		Male	Female
		0,14-0,37	26-22			RCM2D 0.3
	0,5	20			RCM2D 0.5	RCF2D 0.5
	0,75	18			RCM2D 0.7	RCF2D 0.7
	1	18			RCM2D 1.0	RCF2D 1.0
	1,5	16			RCM2D 1.5	RCF2D 1.5
	2,5	14			RCM2D 2.5	RCF2D 2.5
	3	12			RCM2D 3.0	RCF2D 3.0
	4	12			RCM2D 4.0	RCF2D 4.0



Wiring information, RC contacts

conductor section (mm ²)	conductor slot ø A (mm)	stripping length (mm)
0,14-0,37	0,9	7,5
0,5	1,1	7,5
0,75	1,3	7,5
1,0	1,45	7,5
1,5	1,8	7,5
2,5	2,2	7,5
3,0	2,55	7,5
4,0	2,85	7,5

Wire diameter: up to 4,7 mm.

It is recommended to use the crimping tools and removal tools homologated by ILME (please see page [F.23](#))

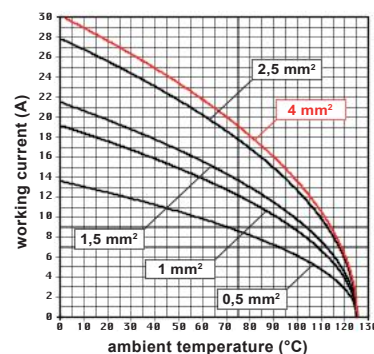
Materials

Insert	polycarbonate (PC)
UL 94 flame rating	V-0
Colour	pebble grey, RAL 7032
Contacts	copper alloy, gold ● plated (HNM version)



CR CPQ
Coding pins
Page [6.3](#)

Enclosures size 44.27	Pages
Specialized Applications	
HNM High Number of Mating cycles	1.74-73



RCE 06 inserts max. current load derating diagram



RCE 10 HNM (High Number of Mating cycles)

16 A 500 V

size **57.27**


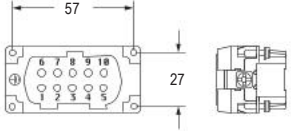

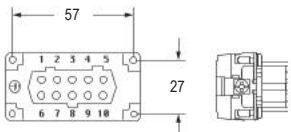
10 poles + ⊕

Crimp connection

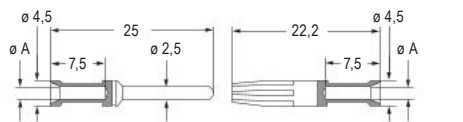
EN 61984 rating	16 A 500 V 6 kV 3
	16 A 400 / 690 V 6 kV 2
Rated voltage (UL / CSA)	600 V
Insulation resistance	≥ 10 GΩ
Contact resistance	≤ 1 mΩ
Ambient temperature limit	-40 °C ... +125 °C
Mechanical life (cycles)	≥ 10 000



CAIUS ECBT2.E115072 | ECBT8.E115072

Item	Description	Part No.	Dimension
	Male inserts for male contacts Without contacts (to be ordered separately)	RCEM 10	
	Female inserts for female contacts Without contacts (to be ordered separately)	RCEF 10	

16 A HNM crimp contacts	section (mm ²)		section (AWG)		Male	Female																	
	0,14-0,37	0,5	0,75	1	1,5	2,5	3	4	RCM2D 0.3	RCF2D 0.3	RCM2D 0.5	RCF2D 0.5	RCM2D 0.7	RCF2D 0.7	RCM2D 1.0	RCF2D 1.0	RCM2D 1.5	RCF2D 1.5	RCM2D 2.5	RCF2D 2.5	RCM2D 3.0	RCF2D 3.0	RCM2D 4.0



Wiring information, RC contacts

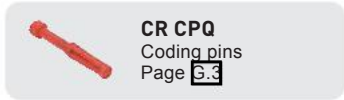
conductor section (mm ²)	conductor slot ø A (mm)	stripping length (mm)
0,14-0,37	0,9	7,5
0,5	1,1	7,5
0,75	1,3	7,5
1,0	1,45	7,5
1,5	1,8	7,5
2,5	2,2	7,5
3,0	2,55	7,5
4,0	2,85	7,5

Wire diameter: up to 4,7 mm.

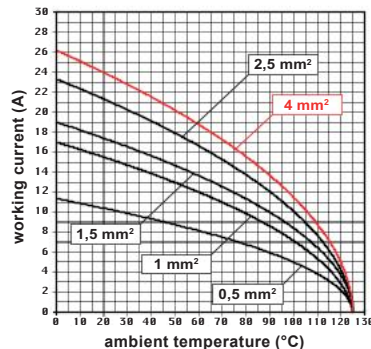
It is recommended to use the crimping tools and removal tools homologated by ILME (please see page [F.23](#))

Materials

Insert	polycarbonate (PC)
UL 94 flame rating	V-0
Colour	pebble grey, RAL 7032
Contacts	copper alloy, gold ● plated (HNM version)



Enclosures size 57.27	Pages
Specialized Applications	
HNM High Number of Mating cycles	1.76-77



RCE 10 inserts max. current load derating diagram

RCE 16 HNM (High Number of Mating cycles)

16 A 500 V

 size **77.27**
16 poles + ⊕

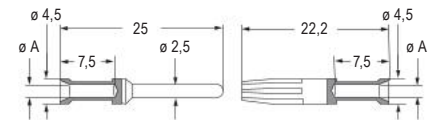
Crimp connection

EN 61984 rating	16 A 500 V 6 kV 3
	16 A 400 / 690 V 6 kV 2
Rated voltage (UL / CSA)	600 V
Insulation resistance	≥ 10 GΩ
Contact resistance	≤ 1 mΩ
Ambient temperature limit	-40 °C ... +125 °C
Mechanical life (cycles)	≥ 10 000



ECBT2.E115072 | ECBT8.E115072

Item	Description	Part No.	Dimension
	Male inserts for male contacts Without contacts (to be ordered separately)	RCEM 16	
	Female inserts for female contacts Without contacts (to be ordered separately)	RCEF 16	
	16 A HNM crimp contacts section (mm ²) section (AWG) 0,14-0,37 26-22 0,5 20 0,75 18 1 18 1,5 16 2,5 14 3 12 4 12	Male RCM2D 0.3 RCM2D 0.5 RCM2D 0.7 RCM2D 1.0 RCM2D 1.5 RCM2D 2.5 RCM2D 3.0 RCM2D 4.0	Female RCF2D 0.3 RCF2D 0.5 RCF2D 0.7 RCF2D 1.0 RCF2D 1.5 RCF2D 2.5 RCF2D 3.0 RCF2D 4.0



Wiring information, RC contacts

conductor section (mm ²)	conductor slot ø A (mm)	stripping length (mm)
0,14-0,37	0,9	7,5
0,5	1,1	7,5
0,75	1,3	7,5
1,0	1,45	7,5
1,5	1,8	7,5
2,5	2,2	7,5
3,0	2,55	7,5
4,0	2,85	7,5

Wire diameter: up to 4,7 mm.

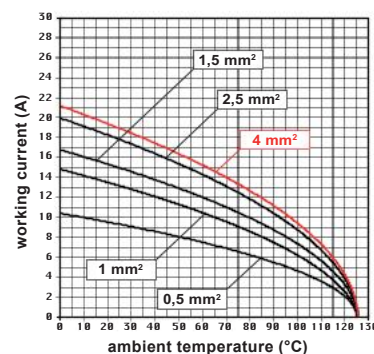
 It is recommended to use the crimping tools and removal tools homologated by ILME (please see page [F.23](#))

Materials

Insert	polycarbonate (PC)
UL 94 flame rating	V-0
Colour	pebble grey, RAL 7032
Contacts	copper alloy, gold ● plated (HNM version)


CR CPQ
 Coding pins
 Page [6.3](#)

Enclosures size 77.27	Pages
Specialized Applications	
HNM High Number of Mating cycles	1.78-79


RCE 16 inserts max. current load derating diagram

RCE 24 HNM (High Number of Mating cycles)

16 A 500 V

size **104.27**

24 poles + ⊕

Crimp connection

EN 61984 rating	16 A 500 V 6 kV 3
	16 A 400 / 690 V 6 kV 2
Rated voltage (UL / CSA)	600 V
Insulation resistance	≥ 10 GΩ
Contact resistance	≤ 1 mΩ
Ambient temperature limit	-40 °C ... +125 °C
Mechanical life (cycles)	≥ 10 000



CAIUS ECBT2.E115072 | ECBT8.E115072

Item	Description	Part No.	Dimension																														
	Male inserts for male contacts Without contacts (to be ordered separately)	RCEM 24																															
	Female inserts for female contacts Without contacts (to be ordered separately)	RCEF 24																															
	<table border="1"> <thead> <tr> <th>16 A HNM crimp contacts</th> <th>Male</th> <th>Female</th> </tr> </thead> <tbody> <tr> <td>section (mm²)</td> <td></td> <td></td> </tr> <tr> <td>0,14-0,37</td> <td>RCM2D 0.3</td> <td>RCF2D 0.3</td> </tr> <tr> <td>0,5</td> <td>RCM2D 0.5</td> <td>RCF2D 0.5</td> </tr> <tr> <td>0,75</td> <td>RCM2D 0.7</td> <td>RCF2D 0.7</td> </tr> <tr> <td>1</td> <td>RCM2D 1.0</td> <td>RCF2D 1.0</td> </tr> <tr> <td>1,5</td> <td>RCM2D 1.5</td> <td>RCF2D 1.5</td> </tr> <tr> <td>2,5</td> <td>RCM2D 2.5</td> <td>RCF2D 2.5</td> </tr> <tr> <td>3</td> <td>RCM2D 3.0</td> <td>RCF2D 3.0</td> </tr> <tr> <td>4</td> <td>RCM2D 4.0</td> <td>RCF2D 4.0</td> </tr> </tbody> </table>	16 A HNM crimp contacts	Male	Female	section (mm ²)			0,14-0,37	RCM2D 0.3	RCF2D 0.3	0,5	RCM2D 0.5	RCF2D 0.5	0,75	RCM2D 0.7	RCF2D 0.7	1	RCM2D 1.0	RCF2D 1.0	1,5	RCM2D 1.5	RCF2D 1.5	2,5	RCM2D 2.5	RCF2D 2.5	3	RCM2D 3.0	RCF2D 3.0	4	RCM2D 4.0	RCF2D 4.0		
16 A HNM crimp contacts	Male	Female																															
section (mm ²)																																	
0,14-0,37	RCM2D 0.3	RCF2D 0.3																															
0,5	RCM2D 0.5	RCF2D 0.5																															
0,75	RCM2D 0.7	RCF2D 0.7																															
1	RCM2D 1.0	RCF2D 1.0																															
1,5	RCM2D 1.5	RCF2D 1.5																															
2,5	RCM2D 2.5	RCF2D 2.5																															
3	RCM2D 3.0	RCF2D 3.0																															
4	RCM2D 4.0	RCF2D 4.0																															

Wiring information, RC contacts

conductor section (mm ²)	conductor slot ø A (mm)	stripping length (mm)
0,14-0,37	0,9	7,5
0,5	1,1	7,5
0,75	1,3	7,5
1,0	1,45	7,5
1,5	1,8	7,5
2,5	2,2	7,5
3,0	2,55	7,5
4,0	2,85	7,5

Wire diameter: up to 4,7 mm.

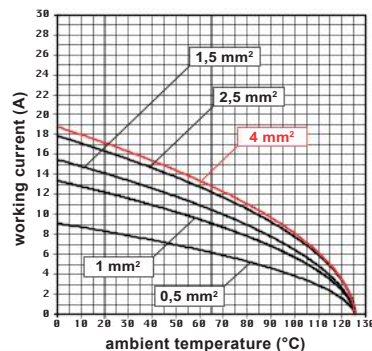
It is recommended to use the crimping tools and removal tools homologated by ILME (please see page [F.23](#))

Materials

Insert	polycarbonate (PC)
UL 94 flame rating	V-0
Colour	pebble grey, RAL 7032
Contacts	copper alloy, gold ● plated (HNM version)

CR CPQ
Coding pins
Page [3.3](#)

Enclosures size 104.27	Pages
Specialized Applications	
HNM High Number of Mating cycles	1.80-81



RCE 24 inserts max. current load derating diagram

RSH 06 HNM (High Number of Mating cycles)

16 A 500 V

size **44.27**
6 poles + ⊕

Tool-less connection – SQUICH®

EN 61984 rating	16 A 500 V 6 kV 3
Rated voltage (UL / CSA)	600 V
Insulation resistance	≥ 10 GΩ
Contact resistance	≤ 3 mΩ
Ambient temperature limit	-40 °C ... +125 °C
Mechanical life (cycles)	≥ 10 000

CE UK EAC

DNV VERITAS (pending: CQC)

CAIUS ECBT2.E115072 | ECBT8.E115072

Item	Description	Part No.	Dimension
	Male inserts with male contacts Spring clamp connections, with actuator button	RSHM 06	
	Female inserts with female contacts Spring clamp connections, with actuator button	RSHF 06	

Materials

Insert	polycarbonate (PC)
UL 94 flame rating	V-0
Colour	pebble grey, RAL 7032
Contacts	built-in, copper alloy, gold ● plated (HNM version)

Wiring information

Wires cross sectional area	
- unprepared	0,14 mm ² - 2,5 mm ² (AWG 26-14)
- prepared	0,14 mm ² - 2,5 mm ² (AWG 26-14)
Stripping length	9...11 mm

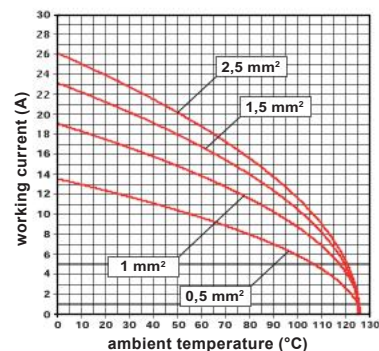
Enclosures size 44.27

Pages

Specialized Applications

HNM High Number of Mating cycles

[1.74-73](#)



RSH 06 inserts max. current load derating diagram



RSH 10 HNM (High Number of Mating cycles)

16 A 500 V

size **57.27**
10 poles + ⊕

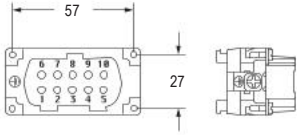
Tool-less connection – SQUICH®

EN 61984 rating	16 A 500 V 6 kV 3
Rated voltage (UL / CSA)	600 V
Insulation resistance	≥ 10 GΩ
Contact resistance	≤ 3 mΩ
Ambient temperature limit	-40 °C ... +125 °C
Mechanical life (cycles)	≥ 10 000

CE UK EAC

DNV VERITAS (pending: CQC)

UL US ECBT2.E115072 | ECBT8.E115072

Item	Description	Part No.	Dimension
	Male inserts with male contacts Spring clamp connections, with actuator button	RSHM 10	
	Female inserts with female contacts Spring clamp connections, with actuator button	RSHF 10	

Materials

Insert	polycarbonate (PC)
UL 94 flame rating	V-0
Colour	pebble grey, RAL 7032
Contacts	built-in, copper alloy, gold ● plated (HNM version)

Wiring information

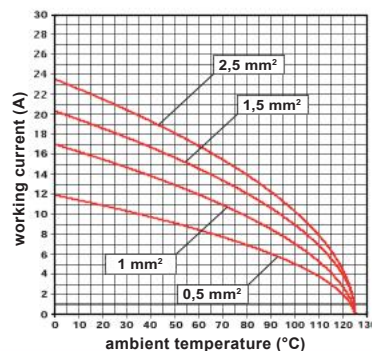
Wires cross sectional area	
- unprepared	0,14 mm ² - 2,5 mm ² (AWG 26-14)
- prepared	0,14 mm ² - 2,5 mm ² (AWG 26-14)
Stripping length	9...11 mm

Enclosures size 57.27

Pages

Specialized Applications

HNM High Number of Mating cycles	1.76-77
----------------------------------	-------------------------



RSH 10 inserts max. current load derating diagram



RSH 16 HNM (High Number of Mating cycles)

16 A 500 V

size **77.27**
16 poles + ⊕

Tool-less connection – SQUICH®

EN 61984 rating	16 A 500 V 6 kV 3
Rated voltage (UL / CSA)	600 V
Insulation resistance	≥ 10 GΩ
Contact resistance	≤ 3 mΩ
Ambient temperature limit	-40 °C ... +125 °C
Mechanical life (cycles)	≥ 10 000



DNV VERITAS (pending: CQC)

CAIUS ECBT2.E115072 | ECBT8.E115072

Item	Description	Part No.	Dimension
	Male inserts with male contacts Spring clamp connections, with actuator button	RSHM 16	
	Female inserts with female contacts Spring clamp connections, with actuator button	RSHF 16	

Materials

Insert	polycarbonate (PC)
UL 94 flame rating	V-0
Colour	pebble grey, RAL 7032
Contacts	built-in, copper alloy, gold ● plated (HNM version)

Wiring information

Wires cross sectional area	
- unprepared	0,14 mm ² - 2,5 mm ² (AWG 26-14)
- prepared	0,14 mm ² - 2,5 mm ² (AWG 26-14)
Stripping length	9...11 mm

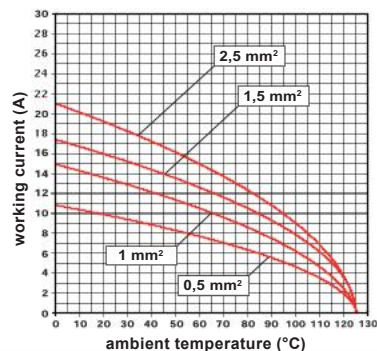
Enclosures size 77.27

Pages

Specialized Applications

HNM High Number of Mating cycles

1.78-79



RSH 16 inserts max. current load derating diagram



RSH 24 HNM (High Number of Mating cycles)

16 A 500 V

size **104.27**
24 poles + ⊕


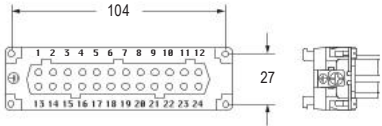
Tool-less connection – SQUICH®

EN 61984 rating	16 A 500 V 6 kV 3
Rated voltage (UL / CSA)	600 V
Insulation resistance	≥ 10 GΩ
Contact resistance	≤ 3 mΩ
Ambient temperature limit	-40 °C ... +125 °C
Mechanical life (cycles)	≥ 10 000

CE UK EAC

DNV VERITAS (pending: CQC)

ALUS ECBT2.E115072 | ECBT8.E115072

Item	Description	Part No.	Dimension
	Male inserts with male contacts Spring clamp connections, with actuator button	RSHM 24	
	Female inserts with female contacts Spring clamp connections, with actuator button	RSHF 24	

Materials

Insert	polycarbonate (PC)
UL 94 flame rating	V-0
Colour	pebble grey, RAL 7032
Contacts	built-in, copper alloy, gold ● plated (HNM version)

Wiring information

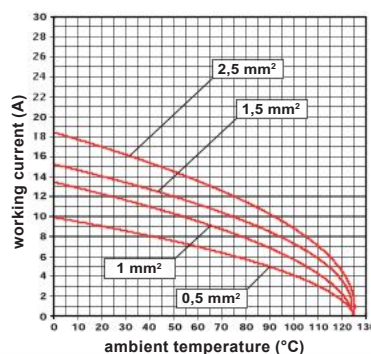
Wires cross sectional area	
- unprepared	0,14 mm ² - 2,5 mm ² (AWG 26-14)
- prepared	0,14 mm ² - 2,5 mm ² (AWG 26-14)
Stripping length	9...11 mm

Enclosures size 104.27

Pages

Specialized Applications

HNM High Number of Mating cycles	1.80-81
----------------------------------	----------------



RSH 24 inserts max. current load derating diagram

RQEE 40 HNM (High Number of Mating cycles)

16 A 500 V


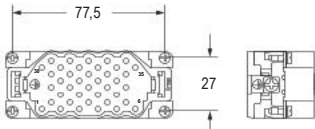

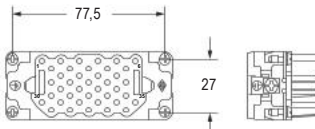

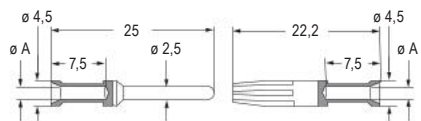
 size **77.27**
40 poles + ⊕

Crimp connection

EN 61984 rating	16 A 500 V 6 kV 3
Rated voltage (UL / CSA)	600 V
Insulation resistance	≥ 10 GΩ
Contact resistance	≤ 1 mΩ
Ambient temperature limit	-40 °C ... +125 °C
Mechanical life (cycles)	≥ 10 000



CRIUS ECBT2.E115072 | ECBT8.E115072

Item	Description	Part No.	Dimension	
	Male inserts for male contacts Without contacts (to be ordered separately)	RQEEM 40		
	Female inserts for female contacts Without contacts (to be ordered separately)	RQEEF 40		
	16 A HNM crimp contacts section (mm ²) section (AWG) 0,14-0,37 26-22 0,5 20 0,75 18 1 18 1,5 16 2,5 14 3 12 4 12	Male gold RCM2D 0.3 RCM2D 0.5 RCM2D 0.7 RCM2D 1.0 RCM2D 1.5 RCM2D 2.5 RCM2D 3.0 RCM2D 4.0	Female RCF2D 0.3 RCF2D 0.5 RCF2D 0.7 RCF2D 1.0 RCF2D 1.5 RCF2D 2.5 RCF2D 3.0 RCF2D 4.0	

Wiring information, RC contacts

conductor section (mm ²)	conductor slot ø A (mm)	stripping length (mm)
0,14-0,37	0,9	7,5
0,5	1,1	7,5
0,75	1,3	7,5
1,0	1,45	7,5
1,5	1,8	7,5
2,5	2,2	7,5
3,0	2,55	7,5
4,0	2,85	7,5

Wire diameter: up to 4,7 mm.

 It is recommended to use the crimping tools and removal tools homologated by ILME (please see page [F.23](#))

Materials

Insert	polycarbonate (PC)
UL 94 flame rating	V-0
Colour	pebble grey, RAL 7032
Contacts	copper alloy, gold ● plated (HNM version)

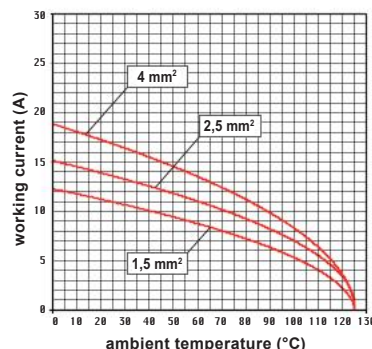

CR CPQ
 Coding pins
 Page [6.3](#)

Enclosures size 77.27

Pages

Specialized Applications

HNM High Number of Mating cycles

[1.78-79](#)

RQEE 40 inserts max. current load derating diagram

RQEE 64 HNM (High Number of Mating cycles)

16 A 500 V

size **104.27**

64 poles + ⊕

Crimp connection

EN 61984 rating	16 A 500 V 6 kV 3
Rated voltage (UL / CSA)	600 V
Insulation resistance	≥ 10 GΩ
Contact resistance	≤ 1 mΩ
Ambient temperature limit	-40 °C ... +125 °C
Mechanical life (cycles)	≥ 10 000



CAIUS ECBT2.E115072 | ECBT8.E115072

Item	Description	Part No.	Dimension	
	Male inserts for male contacts Without contacts (to be ordered separately)	RQEEM 64		
	Female inserts for female contacts Without contacts (to be ordered separately)	RQEEF 64		
	16 A HNM crimp contacts section (mm ²) section (AWG) 0,14-0,37 26-22 0,5 20 0,75 18 1 18 1,5 16 2,5 14 3 12 4 12	Male RCM2D 0.3 RCM2D 0.5 RCM2D 0.7 RCM2D 1.0 RCM2D 1.5 RCM2D 2.5 RCM2D 3.0 RCM2D 4.0	Female RCF2D 0.3 RCF2D 0.5 RCF2D 0.7 RCF2D 1.0 RCF2D 1.5 RCF2D 2.5 RCF2D 3.0 RCF2D 4.0	 Wiring information, RC contacts

Wiring information, RC contacts

conductor section (mm ²)	conductor slot ø A (mm)	stripping length (mm)
0,14-0,37	0,9	7,5
0,5	1,1	7,5
0,75	1,3	7,5
1,0	1,45	7,5
1,5	1,8	7,5
2,5	2,2	7,5
3,0	2,55	7,5
4,0	2,85	7,5

Wire diameter: up to 4,7 mm.

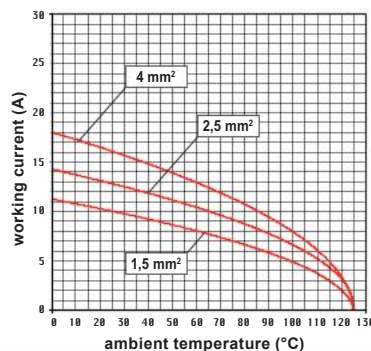
It is recommended to use the crimping tools and removal tools homologated by ILME (please see page [F.23](#))

Materials

Insert	polycarbonate (PC)
UL 94 flame rating	V-0
Colour	pebble grey, RAL 7032
Contacts	copper alloy, gold ● plated (HNM version)

CR CPQ
Coding pins
Page [3.3](#)

Enclosures size 104.27	Pages
Specialized Applications	
HNM High Number of Mating cycles	1.80-81



RQEE 64 inserts max. current load derating diagram

RD 40 HNM (High Number of Mating cycles)

10 A 250 V

size **77.27**


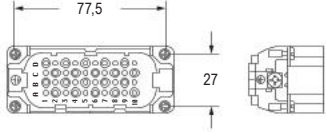

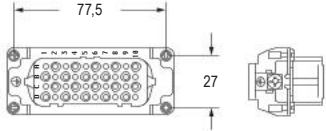

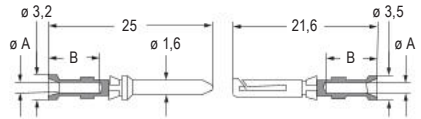
40 poles + ⊕

Crimp connection

EN 61984 rating	10 A 250 V 4 kV 3
	10 A 230 / 400 V 4 kV 2
Rated voltage (UL / CSA)	600 V
Insulation resistance	≥ 10 GΩ
Contact resistance	≤ 3 mΩ
Ambient temperature limit	-40 °C ... +125 °C
Mechanical life (cycles)	≥ 10 000



CAI[®] US ECBT2.E115072 | ECBT8.E115072

Item	Description	Part No.	Dimension																												
	Male inserts for male contacts Without contacts (to be ordered separately)	RDM 40																													
	Female inserts for female contacts Without contacts (to be ordered separately)	RDF 40																													
	10 A HNM crimp contacts <table border="1"> <thead> <tr> <th>section (mm²)</th> <th>section (AWG)</th> </tr> </thead> <tbody> <tr><td>0,14-0,37</td><td>26-22</td></tr> <tr><td>0,5</td><td>20</td></tr> <tr><td>0,75</td><td>18</td></tr> <tr><td>1</td><td>18</td></tr> <tr><td>1,5</td><td>16</td></tr> <tr><td>2,5</td><td>14</td></tr> </tbody> </table>	section (mm ²)	section (AWG)	0,14-0,37	26-22	0,5	20	0,75	18	1	18	1,5	16	2,5	14	<table border="1"> <thead> <tr> <th>Male</th> <th>Female</th> </tr> </thead> <tbody> <tr><td>RDM2D 0.3</td><td>RDF2D 0.3</td></tr> <tr><td>RDM2D 0.5</td><td>RDF2D 0.5</td></tr> <tr><td>RDM2D 0.7</td><td>RDF2D 0.7</td></tr> <tr><td>RDM2D 1.0</td><td>RDF2D 1.0</td></tr> <tr><td>RDM2D 1.5</td><td>RDF2D 1.5</td></tr> <tr><td>RDM2D 2.5</td><td>RDF2D 2.5</td></tr> </tbody> </table>	Male	Female	RDM2D 0.3	RDF2D 0.3	RDM2D 0.5	RDF2D 0.5	RDM2D 0.7	RDF2D 0.7	RDM2D 1.0	RDF2D 1.0	RDM2D 1.5	RDF2D 1.5	RDM2D 2.5	RDF2D 2.5	
section (mm ²)	section (AWG)																														
0,14-0,37	26-22																														
0,5	20																														
0,75	18																														
1	18																														
1,5	16																														
2,5	14																														
Male	Female																														
RDM2D 0.3	RDF2D 0.3																														
RDM2D 0.5	RDF2D 0.5																														
RDM2D 0.7	RDF2D 0.7																														
RDM2D 1.0	RDF2D 1.0																														
RDM2D 1.5	RDF2D 1.5																														
RDM2D 2.5	RDF2D 2.5																														

Wiring information, RD contacts

conductor section (mm ²)	conductor slot ø A (mm)	stripping length B (mm)
0,14-0,37	0,9	8
0,5	1,1	8
0,75	1,3	8
1,0	1,45	8
1,5	1,8	8
2,5	2,2	6

Wire diameter: up to 3,8 mm.

It is recommended to use the crimping tools and removal tools homologated by ILME (please see page [F.23](#))

Materials

Insert	polycarbonate (PC)
UL 94 flame rating	V-0
Colour	pebble grey, RAL 7032
Contacts	copper alloy, gold ● plated (HNM version)



CR CP
Coding pins
Page [E.3](#)

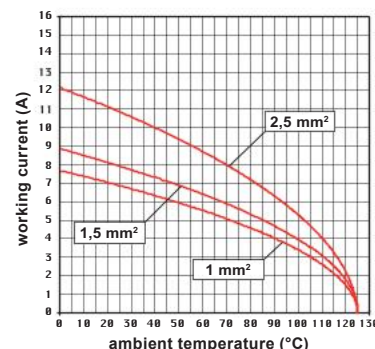
Enclosures size 77.27

Pages

Specialized Applications

HNM High Number of Mating cycles

[1.78-79](#)



RD 40 inserts max. current load derating diagram

For applications requiring higher voltages, please see the special voltage application section on page [E.83](#)

RD 64 HNM (High Number of Mating cycles)

10 A 250 V

size **104.27**

64 poles + ⊕

Crimp connection

EN 61984 rating	10 A 250 V 4 kV 3
	10 A 230 / 400 V 4 kV 2
Rated voltage (UL / CSA)	600 V
Insulation resistance	≥ 10 GΩ
Contact resistance	≤ 3 mΩ
Ambient temperature limit	-40 °C ... +125 °C
Mechanical life (cycles)	≥ 10 000

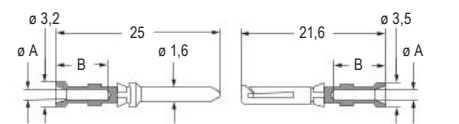


CEC US ECBT2.E115072 | ECBT8.E115072

Item	Description	Part No.	Dimension
	Male inserts for male contacts Without contacts (to be ordered separately)	RDM 64	
	Female inserts for female contacts Without contacts (to be ordered separately)	RDF 64	

10 A HNM crimp contacts		Male	Female
section (mm ²)	section (AWG)		
0,14-0,37	26-22	RDM2D 0.3	RDF2D 0.3
0,5	20	RDM2D 0.5	RDF2D 0.5
0,75	18	RDM2D 0.7	RDF2D 0.7
1	18	RDM2D 1.0	RDF2D 1.0
1,5	16	RDM2D 1.5	RDF2D 1.5
2,5	14	RDM2D 2.5	RDF2D 2.5

Part No.	Male	Female
	RDM2D 0.3	RDF2D 0.3
	RDM2D 0.5	RDF2D 0.5
	RDM2D 0.7	RDF2D 0.7
	RDM2D 1.0	RDF2D 1.0
	RDM2D 1.5	RDF2D 1.5
	RDM2D 2.5	RDF2D 2.5



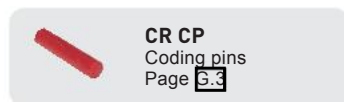
Wiring information, RD contacts

conductor section (mm ²)	conductor slot ø A (mm)	stripping length B (mm)
0,14-0,37	0,9	8
0,5	1,1	8
0,75	1,3	8
1,0	1,45	8
1,5	1,8	8
2,5	2,2	6

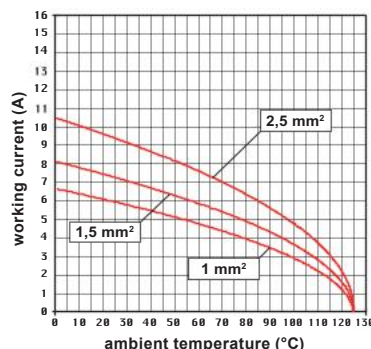
Wire diameter: up to 3,8 mm.

It is recommended to use the crimping tools and removal tools homologated by ILME (please see page [E.23](#))

Materials	
Insert	polycarbonate (PC)
UL 94 flame rating	V-0
Colour	pebble grey, RAL 7032
Contacts	copper alloy, gold ● plated (HNM version)



Enclosures size 104.27	Pages
Specialized Applications	
HNM High Number of Mating cycles	E.80-81



RD 64 inserts max. current load derating diagram

For applications requiring higher voltages, please see the special voltage application section on page [E.83](#)

RDD 24 HNM (High Number of Mating cycles)

10 A 250 V


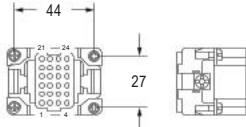

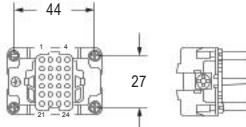

size **44.27**
24 poles + ⊕

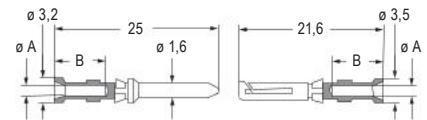
Crimp connection

EN 61984 rating	10 A 250 V 4 kV 2
Rated voltage (UL / CSA)	600 V
Insulation resistance	≥ 10 GΩ
Contact resistance	≤ 3 mΩ
Ambient temperature limit	-40 °C ... +125 °C
Mechanical life (cycles)	≥ 10 000



CAIUS ECBT2.E115072 | ECBT8.E115072

Item	Description	Part No.	Dimension
	Male inserts for male contacts Without contacts (to be ordered separately)	RDDM 24	
	Female inserts for female contacts Without contacts (to be ordered separately)	RDDF 24	
	10 A HNM crimp contacts section (mm ²) section (AWG) 0,14-0,37 26-22 0,5 20 0,75 18 1 18 1,5 16 2,5 14	Male gold RDM2D 0.3 RDM2D 0.5 RDM2D 0.7 RDM2D 1.0 RDM2D 1.5 RDM2D 2.5	Female RDF2D 0.3 RDF2D 0.5 RDF2D 0.7 RDF2D 1.0 RDF2D 1.5 RDF2D 2.5



Wiring information, RD contacts

conductor section (mm ²)	conductor slot ø A (mm)	stripping length B (mm)
0,14-0,37	0,9	8
0,5	1,1	8
0,75	1,3	8
1,0	1,45	8
1,5	1,8	8
2,5	2,2	6

Wire diameter: up to 3,8 mm.

It is recommended to use the crimping tools and removal tools homologated by ILME (please see page [F.23](#))

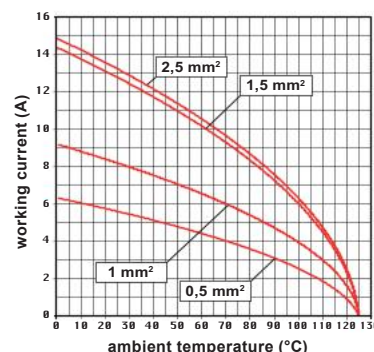
Materials

Insert	polycarbonate (PC)
UL 94 flame rating	V-0
Colour	pebble grey, RAL 7032
Contacts	copper alloy, gold ● plated (HNM version)



CR CP
Coding pins
Page [E.3](#)

Enclosures size 44.27	Pages
Specialized Applications	
HNM High Number of Mating cycles	1.74-75



RDD 24 inserts max. current load derating diagram

For applications requiring higher voltages, please see the special voltage application section on page [E.83](#)



RDD 42 HNM (High Number of Mating cycles)

10 A 250 V

size **57.27**


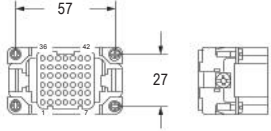
42 poles + ⊕

Crimp connection

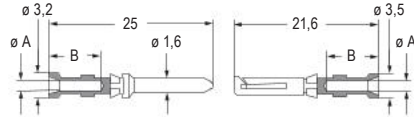
EN 61984 rating	10 A 250 V 4 kV 2
Rated voltage (UL / CSA)	600 V
Insulation resistance	≥ 10 GΩ
Contact resistance	≤ 3 mΩ
Ambient temperature limit	-40 °C ... +125 °C
Mechanical life (cycles)	≥ 10 000



CAIUS ECBT2.E115072 | ECBT8.E115072

Item	Description	Part No.	Dimension
	Male inserts for male contacts Without contacts (to be ordered separately)	RDDM 42	

	Female inserts for female contacts Without contacts (to be ordered separately)	RDDF 42	
--	--	-------------------------	---

10 A HNM crimp contacts	section (mm ²)		section (AWG)		Male	Female	
	0,14-0,37	0,5	0,75	1	1,5	2,5	
	26-22	20	18	18	16	14	

PI08	Male	Female
	RDM2D 0.3	RDF2D 0.3
RDM2D 0.5	RDF2D 0.5	
RDM2D 0.7	RDF2D 0.7	
RDM2D 1.0	RDF2D 1.0	
RDM2D 1.5	RDF2D 1.5	
RDM2D 2.5	RDF2D 2.5	

Wiring information, RD contacts

conductor section (mm ²)	conductor slot ø A (mm)	stripping length B (mm)
0,14-0,37	0,9	8
0,5	1,1	8
0,75	1,3	8
1,0	1,45	8
1,5	1,8	8
2,5	2,2	6

Wire diameter: up to 3,8 mm.

It is recommended to use the crimping tools and removal tools homologated by ILME (please see page [E.23](#))

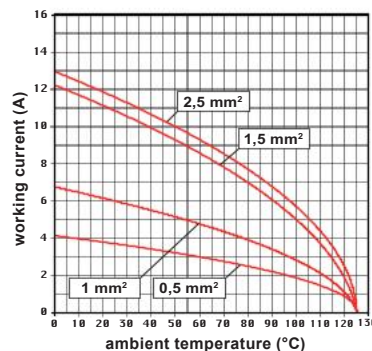
Materials

Insert	polycarbonate (PC)
UL 94 flame rating	V-0
Colour	pebble grey, RAL 7032
Contacts	copper alloy, gold ● plated (HNM version)



CR CP
Coding pins
Page [E.3](#)

Enclosures size 57.27	Pages
Specialized Applications	
HNM High Number of Mating cycles	1.76-77



RDD 42 inserts max. current load derating diagram

For applications requiring higher voltages, please see the special voltage application section on page [E.83](#)

RDD 72 HNM (High Number of Mating cycles)

10 A 250 V


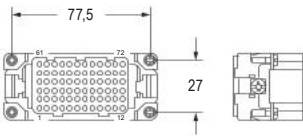

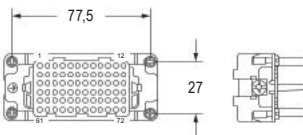

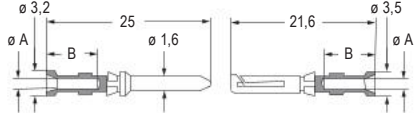
size **77.27**
72 poles + ⊕

Crimp connection

EN 61984 rating	10 A 250 V 4 kV 2
Rated voltage (UL / CSA)	600 V
Insulation resistance	≥ 10 GΩ
Contact resistance	≤ 3 mΩ
Ambient temperature limit	-40 °C ... +125 °C
Mechanical life (cycles)	≥ 10 000



CAI[®] US ECBT2.E115072 | ECBT8.E115072

Item	Description	Part No.	Dimension
	Male inserts for male contacts Without contacts (to be ordered separately)	RDDM 72	
	Female inserts for female contacts Without contacts (to be ordered separately)	RDDF 72	
	10 A HNM crimp contacts section (mm ²) section (AWG)	Male Female	
	0,14-0,37 26-22	gold RDM2D 0.3 RDF2D 0.3	
	0,5 20	RDM2D 0.5 RDF2D 0.5	
	0,75 18	RDM2D 0.7 RDF2D 0.7	
	1 18	RDM2D 1.0 RDF2D 1.0	
	1,5 16	RDM2D 1.5 RDF2D 1.5	
	2,5 14	RDM2D 2.5 RDF2D 2.5	

Wiring information, RD contacts

conductor section (mm ²)	conductor slot ø A (mm)	stripping length B (mm)
0,14-0,37	0,9	8
0,5	1,1	8
0,75	1,3	8
1,0	1,45	8
1,5	1,8	8
2,5	2,2	6

Wire diameter: up to 3,8 mm.

It is recommended to use the crimping tools and removal tools homologated by ILME (please see page [E.23](#))

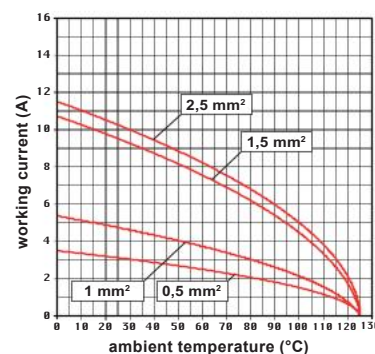
Materials

Insert	polycarbonate (PC)
UL 94 flame rating	V-0
Colour	pebble grey, RAL 7032
Contacts	copper alloy, gold ● plated (HNM version)



CR CP
Coding pins
Page [E.3](#)

Enclosures size 77.27	Pages
Specialized Applications HNM High Number of Mating cycles	E.178-79



RDD 72 inserts max. current load derating diagram

For applications requiring higher voltages, please see the special voltage application section on page [E.83](#)



RDD 108 HNM (High Number of Mating cycles)

10 A 250 V

size **104.27**


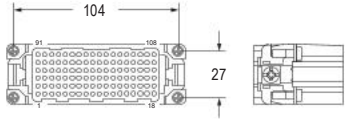

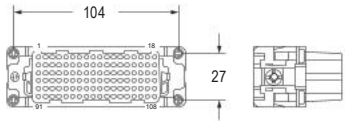
108 poles + ⊕

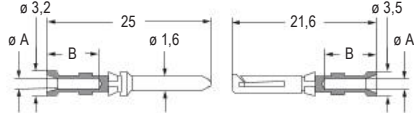
Crimp connection

EN 61984 rating	10 A 250 V 4 kV 2
Rated voltage (UL / CSA)	600 V
Insulation resistance	≥ 10 GΩ
Contact resistance	≤ 3 mΩ
Ambient temperature limit	-40 °C ... +125 °C
Mechanical life (cycles)	≥ 10 000



CEC US ECBT2.E115072 | ECBT8.E115072

Item	Description	Part No.	Dimension
	Male inserts for male contacts Without contacts (to be ordered separately)	RDDM 108	
	Female inserts for female contacts Without contacts (to be ordered separately)	RDDF 108	

10 A HNM crimp contacts	section (mm ²)		section (AWG)		Male	Female	
	0,14-0,37	0,5	0,75	1	1,5	2,5	
	26-22	20	18	18	16	14	
					RDM2D 0.3	RDF2D 0.3	
					RDM2D 0.5	RDF2D 0.5	
					RDM2D 0.7	RDF2D 0.7	
					RDM2D 1.0	RDF2D 1.0	
					RDM2D 1.5	RDF2D 1.5	
					RDM2D 2.5	RDF2D 2.5	

Wiring information, RD contacts

conductor section (mm ²)	conductor slot ø A (mm)	stripping length B (mm)
0,14-0,37	0,9	8
0,5	1,1	8
0,75	1,3	8
1,0	1,45	8
1,5	1,8	8
2,5	2,2	6

Wire diameter: up to 3,8 mm.

It is recommended to use the crimping tools and removal tools homologated by ILME (please see page [F.23](#))

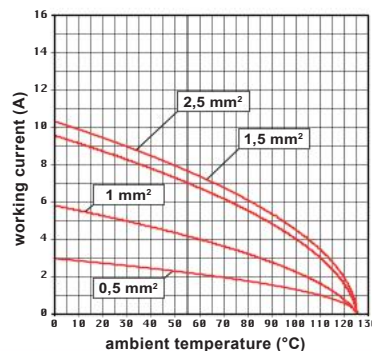
Materials

Insert	polycarbonate (PC)
UL 94 flame rating	V-0
Colour	pebble grey, RAL 7032
Contacts	copper alloy, gold ● plated (HNM version)



CR CP
Coding pins
Page [E.3](#)

Enclosures size 104.27	Pages
Specialized Applications	
HNM High Number of Mating cycles	F.80-81



RDD 108 inserts max. current load derating diagram

For applications requiring higher voltages, please see the special voltage application section on page [E.83](#)


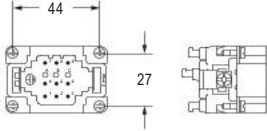

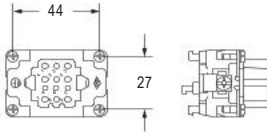
**RDSH 09 HNM (High Number of Mating cycles)****10 A 400 V**size **44.27****9 poles + ⊕****Tool-less connection – SQUICH®**

EN 61984 rating	10 A 400 V 6 kV 3
	10 A 400 / 690 V 6 kV 2
Rated voltage (UL / CSA)	600 V
Insulation resistance	≥ 10 GΩ
Contact resistance	≤ 3 mΩ
Ambient temperature limit	-40 °C ... +125 °C
Mechanical life (cycles)	≥ 10 000



DNV VERITAS (pending: CQC)

CIRIUS ECBT2.E115072 | ECBT8.E115072

Item	Description	Part No.	Dimension
	Male inserts with male contacts Spring clamp connections, with actuator button	RDSHM 09	
	Female inserts with female contacts Spring clamp connections, with actuator button	RDSHF 09	

Materials

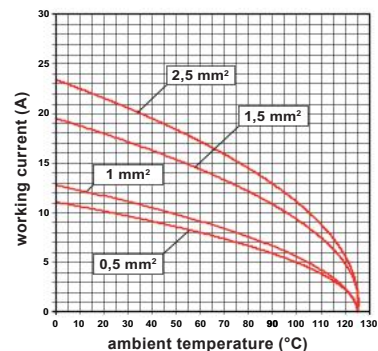
Insert	polycarbonate (PC)
UL 94 flame rating	V-0
Colour	pebble grey, RAL 7032
Contacts	built-in, copper alloy, gold ● plated (HNM version)

Wiring information

Wires cross sectional area	
- unprepared	0,14 mm ² - 2,5 mm ² (AWG 26-14)
- prepared	up to 1,5 mm ² (AWG 16)
Stripping length	9...11 mm

CR CDSCoding pins
Page [6.9](#)**Enclosures size 44.27****Pages****Specialized Applications**

HNM High Number of Mating cycles

1.74-73**RDSH 09 inserts max. current load derating diagram**



RDSH 18 HNM (High Number of Mating cycles)

10 A 400 V

size **57.27**

18 poles + ⊕


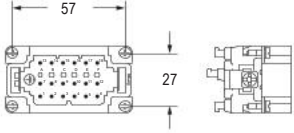

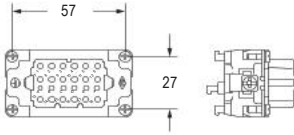
Tool-less connection – SQUICH®

EN 61984 rating	10 A 400 V 6 kV 3
	10 A 400 / 690 V 6 kV 2
Rated voltage (UL / CSA)	600 V
Insulation resistance	≥ 10 GΩ
Contact resistance	≤ 3 mΩ
Ambient temperature limit	-40 °C ... +125 °C
Mechanical life (cycles)	≥ 10 000

CE UK EAC

DNV VERITAS (pending: CQC)

ALUS ECBT2.E115072 | ECBT8.E115072

Item	Description	Part No.	Dimension
	Male inserts with male contacts Spring clamp connections, with actuator button	RDSHM 18	
	Female inserts with female contacts Spring clamp connections, with actuator button	RDSHF 18	

Materials

Insert	polycarbonate (PC)
UL 94 flame rating	V-0
Colour	pebble grey, RAL 7032
Contacts	built-in, copper alloy, gold ● plated (HNM version)

Wiring information

Wires cross sectional area	0,14 mm ² - 2,5 mm ² (AWG 26-14)
- unprepared	up to 1,5 mm ² (AWG 16)
- prepared	9...11 mm
Stripping length	



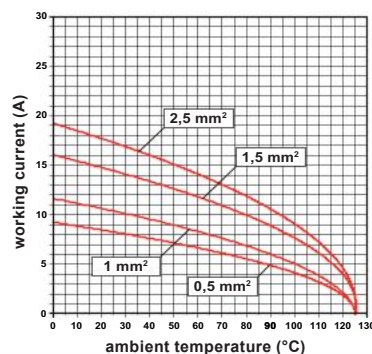
CR CDS
Coding pins
Page [6.9](#)

Enclosures size 57.27

Pages

Specialized Applications

HNM High Number of Mating cycles [1.76-77](#)



RDSH 18 inserts max. current load derating diagram



RDSH 27 HNM (High Number of Mating cycles)

10 A 400 V

size **77.27**
27 poles + ⊕



Tool-less connection – SQUICH®

EN 61984 rating	10 A 400 V 6 kV 3
	10 A 400 / 690 V 6 kV 2
Rated voltage (UL / CSA)	600 V
Insulation resistance	≥ 10 GΩ
Contact resistance	≤ 3 mΩ
Ambient temperature limit	-40 °C ... +125 °C
Mechanical life (cycles)	≥ 10 000



DNV VERITAS (pending: CQC)

CAIUS ECBT2.E115072 | ECBT8.E115072


Item	Description	Part No.	Dimension
	Male inserts with male contacts Spring clamp connections, with actuator button	RDSHM 27	
	Female inserts with female contacts Spring clamp connections, with actuator button	RDSHF 27	

Materials

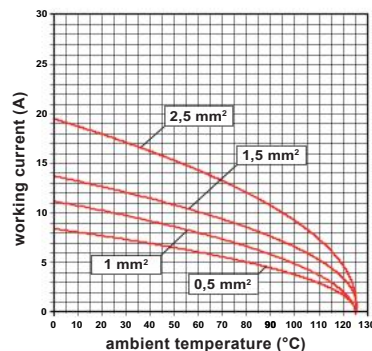
Insert	polycarbonate (PC)
UL 94 flame rating	V-0
Colour	pebble grey, RAL 7032
Contacts	built-in, copper alloy, gold ● plated (HNM version)

Wiring information

Wires cross sectional area	0,14 mm ² - 2,5 mm ² (AWG 26-14)
- unprepared	
- prepared	up to 1,5 mm ² (AWG 16)
Stripping length	9...11 mm

 **CR CDS**
Coding pins
Page [6.9](#)

Enclosures size 77.27	Pages
Specialized Applications	
HNM High Number of Mating cycles	1.78-79



RDSH 27 inserts max. current load derating diagram



RDSH 42 HNM (High Number of Mating cycles)

10 A 400 V

size **104.27**

42 poles + ⊕


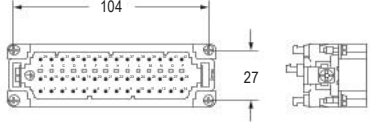

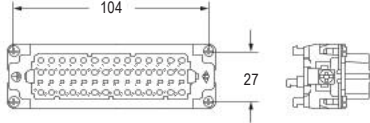
Tool-less connection – SQUICH®

EN 61984 rating	10 A 400 V 6 kV 3
	10 A 400 / 690 V 6 kV 2
Rated voltage (UL / CSA)	600 V
Insulation resistance	≥ 10 GΩ
Contact resistance	≤ 3 mΩ
Ambient temperature limit	-40 °C ... +125 °C
Mechanical life (cycles)	≥ 10 000



DNV VERITAS (pending: CQC)

UL US ECBT2.E115072 | ECBT8.E115072


Item	Description	Part No.	Dimension
	Male inserts with male contacts Spring clamp connections, with actuator button	RDSHM 42	
	Female inserts with female contacts Spring clamp connections, with actuator button	RDSHF 42	

Materials

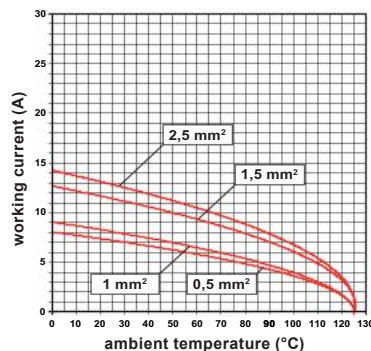
Insert	polycarbonate (PC)
UL 94 flame rating	V-0
Colour	pebble grey, RAL 7032
Contacts	built-in, copper alloy, gold ● plated (HNM version)

Wiring information

Wires cross sectional area	0,14 mm ² - 2,5 mm ² (AWG 26-14)
- unprepared	up to 1,5 mm ² (AWG 16)
- prepared	9...11 mm
Stripping length	

 **CR CDS**
Coding pins
Page [6.9](#)

Enclosures size 104.27	Pages
Specialized Applications	
HNM High Number of Mating cycles	1.80-81



RDSH 42 inserts max. current load derating diagram

RXC 4/2 HNM (High Number of Mating cycles)

80 A 830 V / 16 A 400 V

size **77.27**
4 / 2 poles + ⊕

Crimp connection

EN 61984 rating	80 A 830 V 8 kV 3	16 A 400 V 6 kV 3
Rated voltage (UL / CSA)	600 V	
Insulation resistance	≥ 10 GΩ	
Contact resistance	80 A (4 poles)	≤ 0,3 mΩ
	16 A (2 poles)	≤ 1 mΩ
Ambient temperature limit	-40 °C ... +125 °C	
Mechanical life (cycles)	≥ 10 000	

CE UK (pending: EAC)

(pending: CQC, DNV and BV)

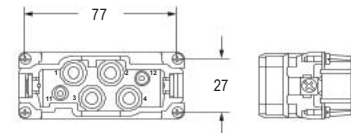
(pending: cURus)

Item	Description	Part No.	Dimension
------	-------------	----------	-----------



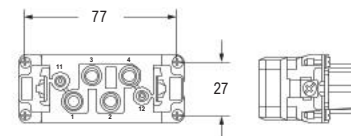
Male inserts for male contacts
Without contacts
(to be ordered separately)

[RXCM 4/2](#)



Female inserts for female contacts
Without contacts
(to be ordered separately)

[RXCF 4/2](#)



80 A HNM crimp contacts	
section (mm ²)	section (AWG)
6	10
10	8-7
16	6-5
16 (XF)*	6-5
25	4-3

Male

Female

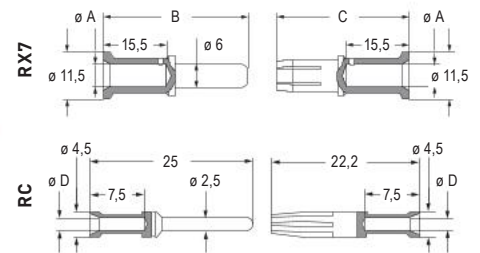
gold	Male	Female
	RX7M2D 6.0	RX7F2D 6.0
	RX7M2D 10	RX7F2D 10
	RX7M2D 16	RX7F2D 16
	RX7M2D 16 XF	RX7F2D 16 XF
	RX7M2D 25	RX7F2D 25



16 A HNM crimp contacts	
section (mm ²)	section (AWG)
0,14-0,37	26-22
0,5	20
0,75	18
1	18
1,5	16
2,5	14
3	12
4	12

gold	Male	Female
	RCM2D 0.3	RCF2D 0.3
	RCM2D 0.5	RCF2D 0.5
	RCM2D 0.7	RCF2D 0.7
	RCM2D 1.0	RCF2D 1.0
	RCM2D 1.5	RCF2D 1.5
	RCM2D 2.5	RCF2D 2.5
	RCM2D 3.0	RCF2D 3.0
	RCM2D 4.0	RCF2D 4.0

* for extra-flexible Class 6 conductors



Wiring information, RX7 and RC contacts

conductor section (mm ²)	conductor slot ø A (mm)	length B (mm)	length C (mm)	conductor section (mm ²)	conductor slot ø D (mm)
6	3,5	36,0	33,0	0,14-0,37	0,9
10	4,3	35,2	32,2	0,5	1,1
16	5,5	35,2	32,2	0,75	1,3
16 (XF)	6,1	35,2	32,2	1,0	1,45
25	7,0	35,2	32,2	1,5	1,8
-	-	-	-	2,5	2,2
-	-	-	-	3,0	2,55
-	-	-	-	4,0	2,85

Wire diameter: up to 10 mm (RX7 series); up to 4,7 mm (RC series).

It is recommended to use the crimping tools and removal tools homologated by ILME (please see page [E.23](#))

Materials

Insert	polycarbonate (PC)
UL 94 flame rating	V-0
Colour	pebble grey, RAL 7032
Contacts	copper alloy, gold ● plated (HNM version)

Enclosures size 77.27

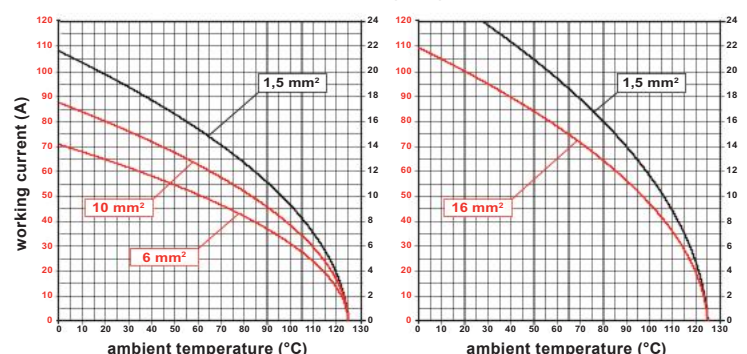
Pages

Specialized Applications

HNM High Number of Mating cycles

1.78-79

RXC 4/2 inserts max. current load derating diagrams



Can be used in bulkhead mounting housings or in high construction housings or in high construction hoods.

RXC 4/8 HNM (High Number of Mating cycles)

80 A 400 V / 16 A 230/400 V

size **104.27**

4 / 8 poles + ⊕

Crimp connection

EN 61984 rating	80 A 400 V 6 kV 3
	16 A 230 / 400 V 4 kV 3
Rated voltage (UL / CSA)	600 V
Insulation resistance	≥ 10 GΩ
Contact resistance	80 A (4 poles) ≤ 0,3 mΩ
	16 A (8 poles) ≤ 1 mΩ
Ambient temperature limit	-40 °C ... +125 °C
Mechanical life (cycles)	≥ 10 000

CE UK (pending: EAC)

(pending: CQC, DNV and BV)

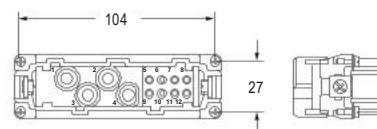
(pending: cURus)

Item	Description	Part No.	Dimension
------	-------------	----------	-----------



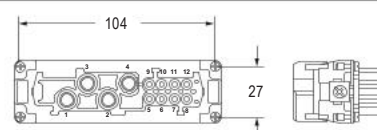
Male inserts for male contacts
Without contacts
(to be ordered separately)

[RXCM 4/8](#)



Female inserts for female contacts
Without contacts
(to be ordered separately)

[RXCF 4/8](#)



80 A HNM crimp contacts

section (mm ²)	section (AWG)
6	10
10	8-7
16	6-5
16 (XF)*	6-5
25	4-3

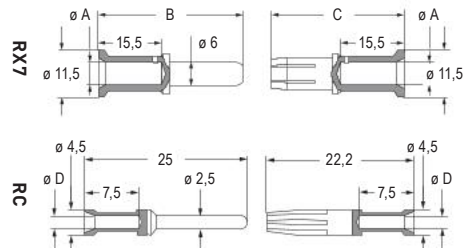
Male

Female

gold

RX7M2D 6.0
RX7M2D 10
RX7M2D 16
RX7M2D 16 XF
RX7M2D 25

RX7F2D 6.0
RX7F2D 10
RX7F2D 16
RX7F2D 16 XF
RX7F2D 25



16 A HNM crimp contacts

section (mm ²)	section (AWG)
0,14-0,37	26-22
0,5	20
0,75	18
1	18
1,5	16
2,5	14
3	12
4	12

gold

RCM2D 0.3
RCM2D 0.5
RCM2D 0.7
RCM2D 1.0
RCM2D 1.5
RCM2D 2.5
RCM2D 3.0
RCM2D 4.0

RCF2D 0.3
RCF2D 0.5
RCF2D 0.7
RCF2D 1.0
RCF2D 1.5
RCF2D 2.5
RCF2D 3.0
RCF2D 4.0

Wiring information, RX7 and RC contacts

conductor section (mm ²)	conductor slot ø A (mm)	length B (mm)	length C (mm)	conductor section (mm ²)	conductor slot ø D (mm)
6	3,5	36,0	33,0	0,14-0,37	0,9
10	4,3	35,2	32,2	0,5	1,1
16	5,5	35,2	32,2	0,75	1,3
16 (XF)	6,1	35,2	32,2	1,0	1,45
25	7,0	35,2	32,2	1,5	1,8
-	-	-	-	2,5	2,2
-	-	-	-	3,0	2,55
-	-	-	-	4,0	2,85

* for extra-flexible Class 6 conductors

Wire diameter: up to 10 mm (RX7 series); up to 4,7 mm (RC series).

It is recommended to use the crimping tools and removal tools homologated by ILME (please see page [F.23](#))

Materials

Insert	polycarbonate (PC)
UL 94 flame rating	V-0
Colour	pebble grey, RAL 7032
Contacts	copper alloy, gold ● plated (HNM version)

The derating curves for the connector's **power** and **signal** poles in the diagrams below are valid for the following combinations:

- power 4 mm² with signal 1 mm²;
- power 6 mm² with signal 1 mm²;
- power 10 mm² or 6 mm² with signal 1,5 mm²;
- power 16 mm² with signal 2,5 mm².

Enclosures size 104.27

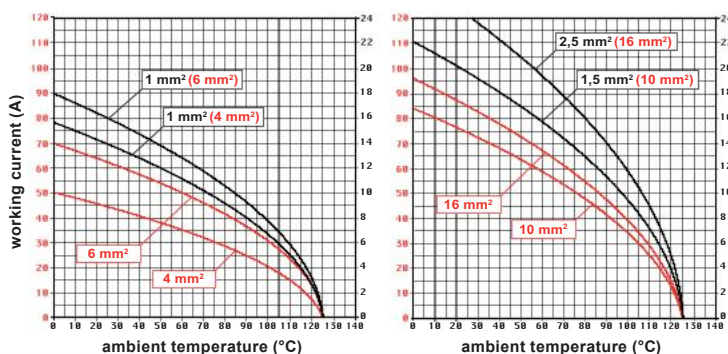
Pages

Specialized Applications

HNM High Number of Mating cycles

-1.80-81

RXC 4/8 inserts max. current load derating diagrams



Can be used in bulkhead mounting housings or in high construction housings or in high construction hoods.

RX 12/2 HNM (High Number of Mating cycles)

40 A 690 V / 10 A 250 V

size **77.27**
12 / 2 poles + ⊕

Crimp connection

EN 61984 rating	40 A 690 V 8 kV 3	10 A 250 V 4 kV 3
Rated voltage (UL / CSA)	600 V	
Insulation resistance	≥ 10 GΩ	
Contact resistance	40 A (12 poles)	≤ 0,3 mΩ
	10 A (2 poles)	≤ 1 mΩ
Ambient temperature limit	-40 °C ... +125 °C	
Mechanical life (cycles)	≥ 10 000	



CAIUS ECBT2.E115072 | ECBT8.E115072

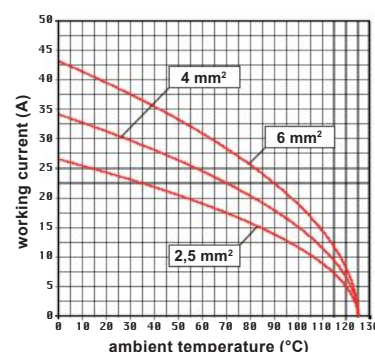
Item	Description	Part No.	Dimension																																										
	Male inserts for male contacts Without contacts (to be ordered separately)	RXM 12/2																																											
	Female inserts for female contacts Without contacts (to be ordered separately)	RXF 12/2																																											
	40 A HNM crimp contacts section (mm ²) section (AWG) 1,5 16 2,5 14 4 12 6 10	Male gold RXM2D 1.5 RXM2D 2.5 RXM2D 4.0 RXM2D 6.0	Female RXF2D 1.5 RXF2D 2.5 RXF2D 4.0 RXF2D 6.0																																										
	10 A HNM crimp contacts section (mm ²) section (AWG) 0,14-0,37 26-22 0,5 20 0,75 18 1 18 1,5 16 2,5 14	gold RDM2D 0.3 RDM2D 0.5 RDM2D 0.7 RDM2D 1.0 RDM2D 1.5 RDM2D 2.5	RDF2D 0.3 RDF2D 0.5 RDF2D 0.7 RDF2D 1.0 RDF2D 1.5 RDF2D 2.5																																										
			 Wiring information, RX and RD contacts <table border="1"> <thead> <tr> <th>conductor section (mm²)</th> <th>conductor slot ø A (mm)</th> <th>stripping length B (mm)</th> <th>conductor section (mm²)</th> <th>conductor slot ø C (mm)</th> <th>stripping length D (mm)</th> </tr> </thead> <tbody> <tr> <td>1,5</td> <td>1,8</td> <td>9</td> <td>0,14-0,37</td> <td>0,9</td> <td>8</td> </tr> <tr> <td>2,5</td> <td>2,2</td> <td>9</td> <td>0,5</td> <td>1,1</td> <td>8</td> </tr> <tr> <td>4</td> <td>2,85</td> <td>9,6</td> <td>0,75</td> <td>1,3</td> <td>8</td> </tr> <tr> <td>6</td> <td>3,5</td> <td>9,6</td> <td>1,0</td> <td>1,45</td> <td>8</td> </tr> <tr> <td>-</td> <td>-</td> <td>-</td> <td>1,5</td> <td>1,8</td> <td>8</td> </tr> <tr> <td>-</td> <td>-</td> <td>-</td> <td>2,5</td> <td>2,2</td> <td>6</td> </tr> </tbody> </table>	conductor section (mm ²)	conductor slot ø A (mm)	stripping length B (mm)	conductor section (mm ²)	conductor slot ø C (mm)	stripping length D (mm)	1,5	1,8	9	0,14-0,37	0,9	8	2,5	2,2	9	0,5	1,1	8	4	2,85	9,6	0,75	1,3	8	6	3,5	9,6	1,0	1,45	8	-	-	-	1,5	1,8	8	-	-	-	2,5	2,2	6
conductor section (mm ²)	conductor slot ø A (mm)	stripping length B (mm)	conductor section (mm ²)	conductor slot ø C (mm)	stripping length D (mm)																																								
1,5	1,8	9	0,14-0,37	0,9	8																																								
2,5	2,2	9	0,5	1,1	8																																								
4	2,85	9,6	0,75	1,3	8																																								
6	3,5	9,6	1,0	1,45	8																																								
-	-	-	1,5	1,8	8																																								
-	-	-	2,5	2,2	6																																								

Wire diameter: up to 5,3 mm (RX series); up to 3,8 mm (RD series).
 For basic or high thickness gold plating, please refer to page [F.16](#)
 It is recommended to use the crimping tools and removal tools homologated by ILME (please see page [F.23](#))

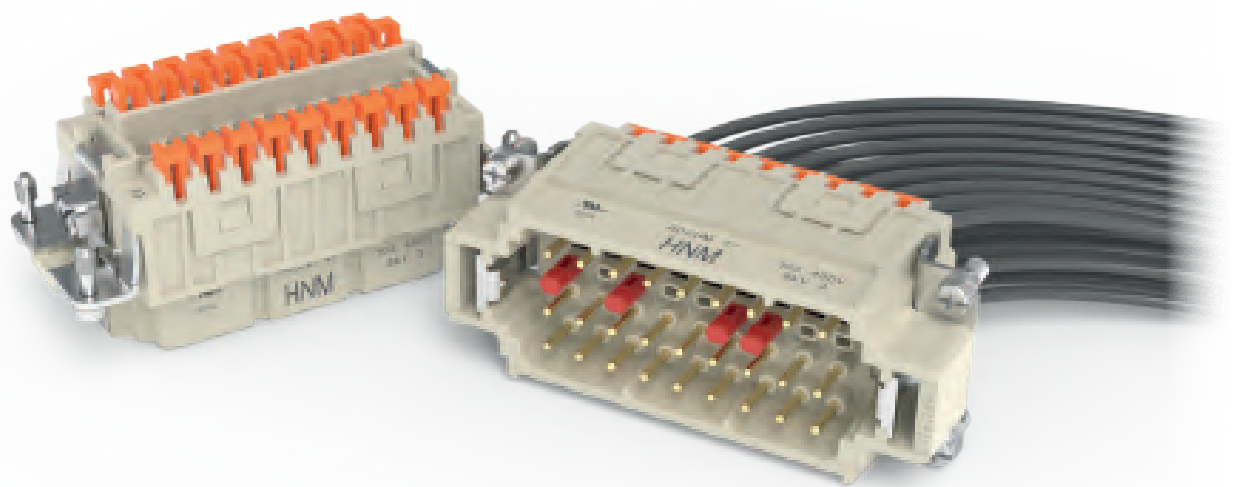
Materials

Insert	polycarbonate (PC)
UL 94 flame rating	V-0
Colour	pebble grey, RAL 7032
Contacts	copper alloy, gold plated (HNM version)

Enclosures size 77.27	Pages
Specialized Applications	
HNM High Number of Mating cycles	1.78-79



RX 12/2 inserts max. current load derating diagram



HNM

modular inserts



Within the range of the **HNM products**, all MIXO modules for 70 A, 40 A, 16 A and 10 A contacts, combined with the use of the specifically designed high-thickness gold-plated and lubricated HNM contacts of:

- > **RX7** series 80 A HNM variant of CX7 series
- > **RX** series 40 A HNM variant of CX series
- > **RC** series 16 A HNM variant of CC series
- > **RD** series 10 A HNM variant of CD series
- > **RI** series 5 A HNM variant of CI series

and mounted in the dedicated **MIXO HNM frames RX 02 /03 /04 /06 TF /TM**, also employing especially gold-plated PE contacts, allow the creation of HNM modular connector inserts for up to 10 000 mating cycles.

Specialized HNM applications to be used outside of an enclosure system can also benefit from the ILME self-centring floating frames **CX 02 /03 /04 /06 DF /DM** or the MIXO thermoplastic docking frames, **CX 02 /03 /04 /06 PDF /PDM**. Simple and economical solutions of providing a self-centring docking frame for drawer-like connections realized with MIXO modular inserts.

- > **Up to 10 000 matings in combination with HNM enclosures**
- > **Up to 5 000 matings with standard hoods with single lever**

NOTE: For contacts in the HNM version (RI, RD, RC, RX and RX7 series), the same tools are suitable for crimping, insertion/extraction (where indicated) as those used for the corresponding contacts in the standard version (respectively CI, CD, CC, CX and CX7 series).



The MIXO modules that by using HNM 40 A contacts series RX, HNM 16 A contacts series RC and HNM 10 A contacts series RD together with MIXO HNM frames RX 02...06 TF/M can create MIXO HNM modular connector inserts are:

- > **CX 02 7F /M**
with 70 A HNM crimp contacts RX7 series
- > **CX 04 XF /XM**
with 40 A HNM crimp contacts RX series
- > **CX 3/4 XDF /M**
with 40 A and 10 A HNM crimp contacts RX and RD series
- > **CX 06 CF /M**
CX 06P CF /M
CX 08 CF /M
CX 20 CF /M
with 16 A HNM crimp contacts RC series
- > **CX 02 4F /M**
CX 03 4F /M
CX 03 4BF /M
series with 16 A and HNM crimp contacts RD series
- > **CX 12 DF /M**
CX 17 DF /M
CX 42 DF /M
series with 16 A and HNM crimp contacts RD series
- > **CX 36 IF /M**
CX 25 IBF /IBM
with 5 A HNM crimp contacts RI series
- > **RX 08 D5F /M**
RX 08 D5GF /M
RX 08 I6F /M
RX 08 I6GF /M
RX 20S IF /M
RX 20S IGF /M
with 5 A HNM crimp contacts RI series

HNM modular inserts

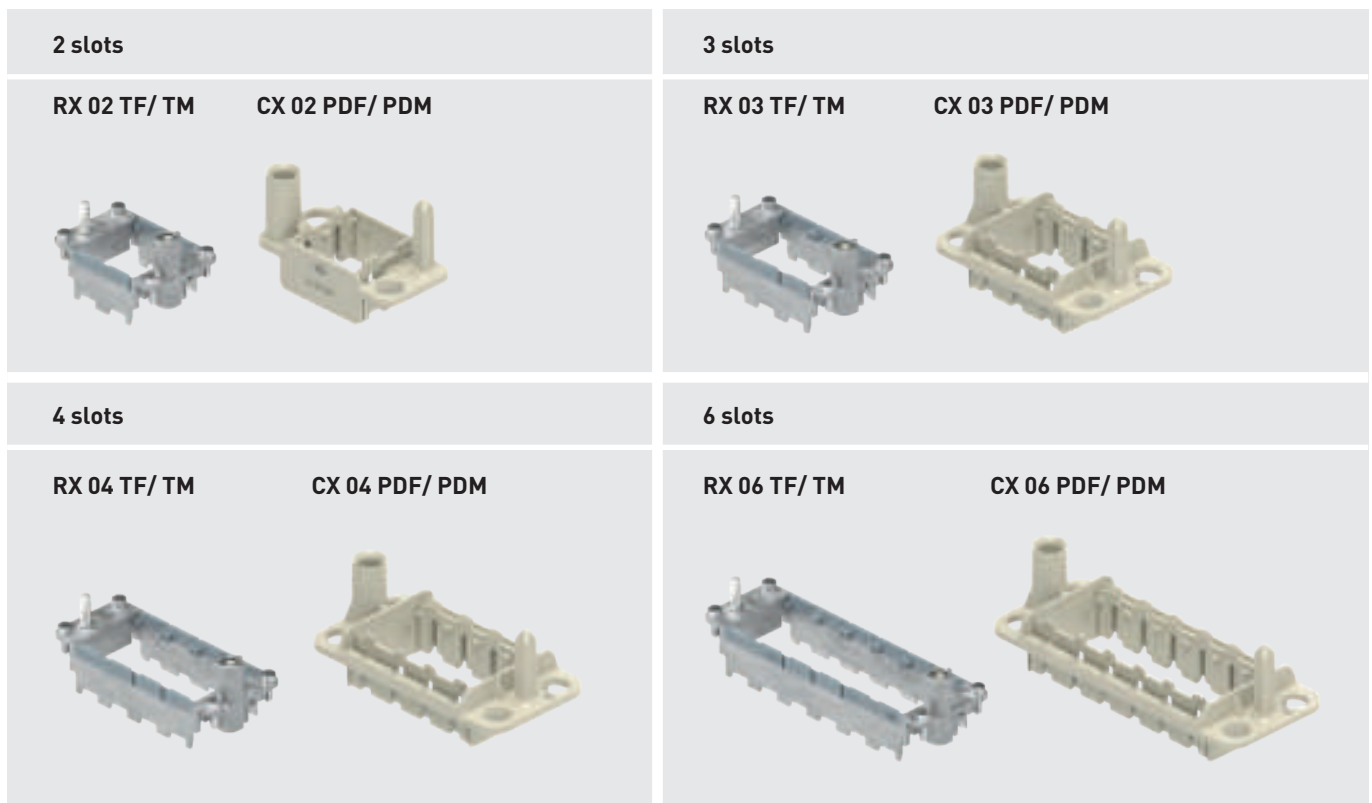
HNM modular inserts, once assembled as multi-module insert, can be directly mounted in both of the following metal and in the MIXO thermoplastic **docking frames** (see page H.62).

Metal frames	Enclosures size	Docking frames
RX 02 TF/ RX 02 TM	44.27	CX 02 PDF/ PDM
RX 03 TF/ RX 03 TM	57.27	CX 03 PDF/ PDM
RX 04 TF/ RX 04 TM	77.27	CX 04 PDF/ PDM
RX 06 TF/ RX 06 TM	104.27	CX 06 PDF/ PDM
RX 04 TF/ RX 04 TM (× 2)	77.62	--
RX 06 TF/ RX 06 TM (× 2)	104.62	--

Use the **MIXO HNM frames** (provided with special gold plated PE contacts) together with R series of crimp contacts and the relevant connector hoods and housings, to produce, where required, an **HNM connector** (High Number of Mating cycles, up to 10 000 cycles of operation).

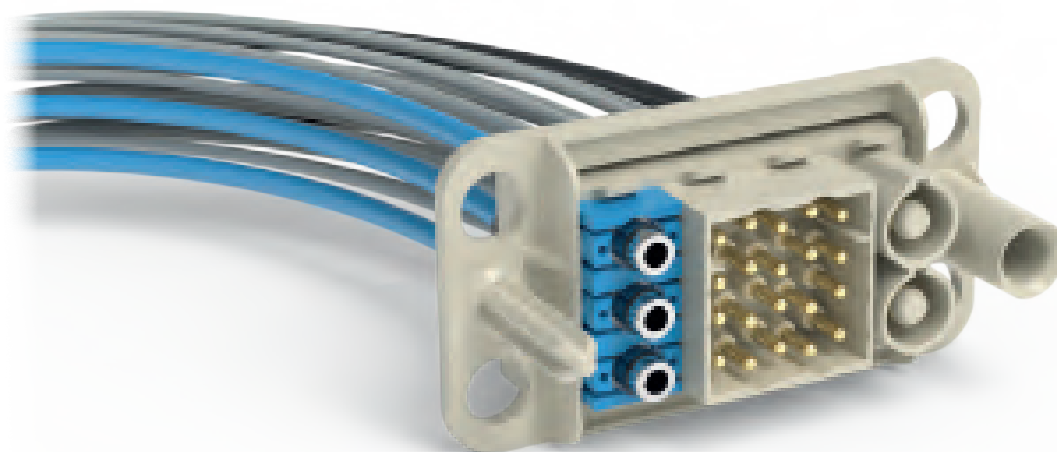
Single-sized modules, where specified, can also be installed directly inside **MIXO ONE** and **MIXO TWO** enclosures.

NOTE: MIXO thermoplastic docking frames cannot be mounted inside enclosures.



In addition, HNM modular inserts can be used with the COB series panel supports:

Frames	COB panel supports part No.
RX 02 TF/ RX 02 TM (fixed)	COB 06 BC and COB TCQ
RX 02 TF/ RX 02 TM (mobile)	COB TSF, COB TSFS and COB 06 CMS
RX 03 TF/ RX 03 TM (fixed)	COB 10 BC and COB TCQ
RX 03 TF/ RX 03 TM (mobile)	COB TSF, COB TSFS and COB 10 CMS
RX 04 TF/ RX 04 TM (fixed)	COB 16 BC and COB TCQ
RX 04 TF/ RX 04 TM (mobile)	COB TSF, COB TSFS and COB 16 CMS
RX 06 TF/ RX 06 TM (fixed)	COB 24 BC and COB TCQ
RX 06 TF/ RX 06 TM (mobile)	COB TSF, COB TSFS and COB 24 CMS



CX 02 7 HNM (High Number of Mating cycles)

70 A 1000 V

 size **1 module**
2 poles
Crimp connection

EN 61984 rating	70 A 1 000 V 8 kV 3
	70 A 1 600 V 12 kV 2
Rated voltage (UL / CSA)	600 V
Insulation resistance	≥ 10 GΩ
Contact resistance	≤ 0,5 mΩ
Ambient temperature limit	-40 °C ... +125 °C
Mechanical life (cycles)	≥ 10 000



(pending: CQC)

ECBT2.E115072 | ECBT8.E115072

Item	Description	Part No.	Dimension
	Male inserts for male contacts Without contacts (to be ordered separately)	CX 02 7M	
	Female inserts for female contacts Without contacts (to be ordered separately)	CX 02 7F	
	70 A HNM crimp contacts section (mm ²) section (AWG) 10 8-7 16 6-5 16 (XF)* 6-5 25 4-3	Male gold RX7M2D 10 RX7M2D 16 RX7M2D 16 XF RX7M2D 25	Female RX7F2D 10 RX7F2D 16 RX7F2D 16 XF RX7F2D 25
	70 A HNM finger-proof crimp contacts section (mm ²) section (AWG) 6 10 10 8-7 16 6-5 16 (XF)* 6-5 25 4-3	gold RX7M2D 6.0 P RX7M2D 10 P RX7M2D 16 P RX7M2D 16XFP RX7M2D 25 P	<p>conductor stripping length: 15 mm</p>

* for extra-flexible Class 6 conductors

Wiring information, RX7 and RX7 P contacts

conductor section (mm ²)	conductor slot ø A (mm)	length B (mm)	length C (mm)	length D (mm)
6	3,5	36,0	33,0	36,6
10	4,3	35,2	32,2	35,8
16	5,5	35,2	32,2	35,8
16 (XF)	6,1	35,2	32,2	35,8
25	7,0	35,2	32,2	35,8

Wire diameter: up to 10 mm.

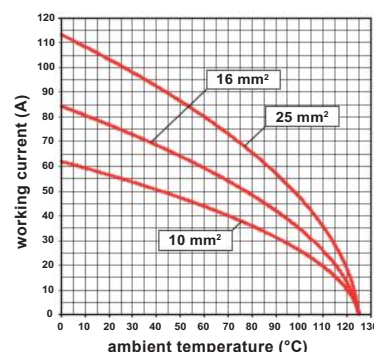
 It is recommended to use the crimping tools and removal tools homologated by ILME (please see page [E.23](#))

Materials

Insert	polycarbonate (PC)
UL 94 flame rating	V-0
Colour	pebble grey, RAL 7032
Contacts	copper alloy, gold ● plated (HNM version)

Accessories

	Pages
MIXO Frames	
Metal frames for HNM modular units	1.62
Thermoplastic docking frames	1.65-68


CX 02 7 inserts max. current load derating diagram

Can be used in bulkhead mounting housings or in high construction housings or in high construction hoods.

CX 02 4 HNM (High Number of Mating cycles)

40 A 1000 V

size **1 module**
2 poles


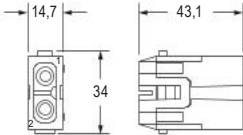

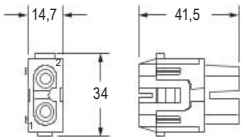
Crimp connection

EN 61984 rating	40 A 1 000 V 8 kV 3
Rated voltage (UL / CSA)	600 V
Insulation resistance	≥ 10 GΩ
Contact resistance	≤ 0,3 mΩ
Ambient temperature limit	-40 °C ... +125 °C
Mechanical life (cycles)	≥ 10 000

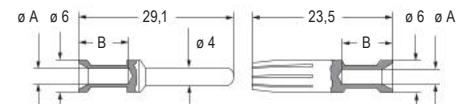
CE UK EAC

DNV VERITAS (pending: CQC)

CALUS ECBT2.E115072 | ECBT8.E115072

Item	Description	Part No.	Dimension
	Male inserts for male contacts Without contacts (to be ordered separately)	CX 02 4M	
	Female inserts for female contacts Without contacts (to be ordered separately)	CX 02 4F	

40 A HNM crimp contacts		Male	Female
section (mm ²)	section (AWG)		
1,5	16	RXM2D 1.5	RXF2D 1.5
2,5	14	RXM2D 2.5	RXF2D 2.5
4	12	RXM2D 4.0	RXF2D 4.0
6	10	RXM2D 6.0	RXF2D 6.0
10	8	RXM2D 10	RXF2D 10




Wiring information, RX contacts

conductor section (mm ²)	conductor slot ø A (mm)	stripping length B (mm)
1,5	1,8	9
2,5	2,2	9
4	2,85	9,6
6	3,5	9,6
10	4,3	15

Wire diameter: up to 7 mm.

It is recommended to use the crimping tools and removal tools homologated by ILME (please see page [E.23](#))

Materials

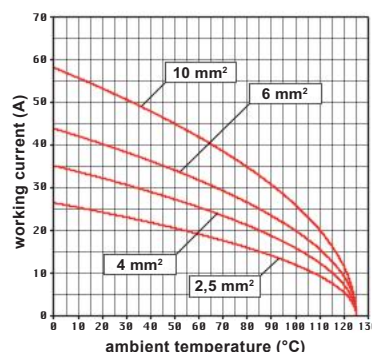
Insert	polycarbonate (PC)
UL 94 flame rating	V-0
Colour	pebble grey, RAL 7032
Contacts	copper alloy, gold  plated (HNM version)

Accessories

Pages

MIXO Frames	
Metal frames for HNM modular units	1.62
Thermoplastic docking frames	1.65-68

Can be used in bulkhead mounting housings or in high construction housings or in high construction hoods.



CX 02 4 inserts max. current load derating diagram


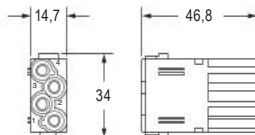

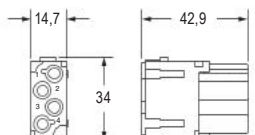
**CX 04 X HNM (High Number of Mating cycles)****40 A 830 V**size **1 module****4 poles****Crimp connection**





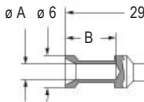
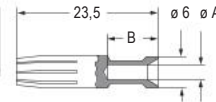
EN 61984 rating	40 A 830 V 8 kV 3
	40 A 1 000 V 8 kV 2
Rated voltage (UL / CSA)	600 V
Insulation resistance	≥ 10 GΩ
Contact resistance	≤ 0,3 mΩ
Ambient temperature limit	-40 °C ... +125 °C
Mechanical life (cycles)	≥ 10 000



DNV VERITAS (pending: CQC)

CFLUS ECBT2.E115072 | ECBT8.E115072

Item	Description	Part No.	Dimension
	Male inserts for male contacts Without contacts (to be ordered separately) Male insert is protected from access with the back of the hand (IP1X or IPXXA)	CX 04 XM	
	Female inserts for female contacts Without contacts (to be ordered separately) Female insert is finger proof (IP2X or IPXXB) even if not coupled Female inserts are supplied with × 2 red lock-in tab that must be used instead of those supplied with the frames (code CX CFMX)	CX 04 XF	

40 A HNM crimp contacts section (mm ²)	section (AWG)	Male		Female	
					
1,5	16	RXM2D 1.5	RXF2D 1.5		
2,5	14	RXM2D 2.5	RXF2D 2.5		
4	12	RXM2D 4.0	RXF2D 4.0		
6	10	RXM2D 6.0	RXF2D 6.0		

Wiring information, RX contacts

conductor section (mm ²)	conductor slot ø A (mm)	stripping length B (mm)
1,5	1,8	9
2,5	2,2	9
4	2,85	9,6
6	3,5	9,6

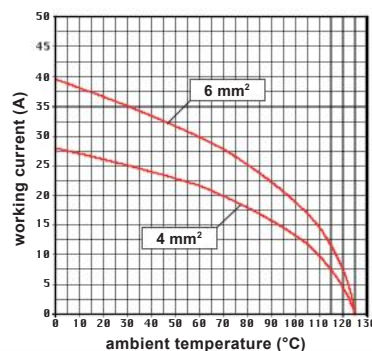
Wire diameter: up to 5,3 mm.

It is recommended to use the crimping tools and removal tools homologated by ILME (please see page [F.23](#))**Materials**

Insert	polycarbonate (PC)
UL 94 flame rating	V-0
Colour	pebble grey, RAL 7032
Contacts	copper alloy, gold  plated (HNM version)

Accessories**Pages**

Accessories	Pages
MIXO Frames	
Metal frames for HNM modular units	1.62
Thermoplastic docking frames	1.65-68

**CX 04 X inserts max. current load derating diagram**

Can be used in bulkhead mounting housings or in high construction housings or in high construction hoods.

CX 3/4 XD HNM (High Number of Mating cycles)

40 A 830 V / 10 A 830 V

size **1 module**

3 / 4 poles

Crimp connection

EN 61984 rating	40 A 830 V 8 kV 3
	10 A 830 V 8 kV 3
Rated voltage (UL / CSA)	600 V
Insulation resistance	≥ 10 GΩ
Contact resistance	40 A (3 poles) ≤ 0,3 mΩ
	10 A (4 poles) ≤ 3 mΩ
Ambient temperature limit	-40 °C ... +125 °C
Mechanical life (cycles)	≥ 10 000



DNV VERITAS (pending: CQC)

CBUS ECBT2.E115072 | ECBT8.E115072

Item	Description	Part No.	Dimension
	Male inserts for male contacts Without contacts (to be ordered separately) Male insert is protected from access with the back of the hand (IP1X or IPXXA)	CX 3/4 XDM	

	Female inserts for female contacts Without contacts (to be ordered separately) Female insert is finger proof (IP2X or IPXXB) even if not coupled	CX 3/4 XDF	
--	--	----------------------------	--

	40 A HNM crimp contacts	Male	Female	
	section (mm ²) section (AWG)			
	1,5 16	RXM2D 1.5	RXF2D 1.5	
	2,5 14	RXM2D 2.5	RXF2D 2.5	
	4 12	RXM2D 4.0	RXF2D 4.0	
	6 10	RXM2D 6.0	RXF2D 6.0	
	10 A HNM crimp contacts			
	section (mm ²) section (AWG)			
	0,14-0,37 26-22	RDM2D 0.3	RDF2D 0.3	
	0,5 20	RDM2D 0.5	RDF2D 0.5	
	0,75 18	RDM2D 0.7	RDF2D 0.7	
	1 18	RDM2D 1.0	RDF2D 1.0	
	1,5 16	RDM2D 1.5	RDF2D 1.5	
	2,5 14	RDM2D 2.5	RDF2D 2.5	

Wiring information, RX and RD contacts

conductor section (mm ²)	conductor slot ø A (mm)	stripping length B (mm)	conductor section (mm ²)	conductor slot ø C (mm)	stripping length D (mm)
1,5	1,8	9	0,14-0,37	0,9	8
2,5	2,2	9	0,5	1,1	8
4	2,85	9,6	0,75	1,3	8
6	3,5	9,6	1,0	1,45	8
-	-	-	1,5	1,8	8
-	-	-	2,5	2,2	6

Wire diameter: up to 5,3 mm (RX series); up to 3,8 mm (RD series).

It is recommended to use the crimping tools and removal tools homologated by ILME (please see page [E.23](#))

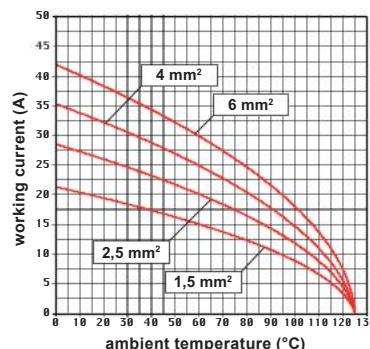
Materials

Insert	polycarbonate (PC)
UL 94 flame rating	V-0
Colour	pebble grey, RAL 7032
Contacts	copper alloy, gold plated (HNM version)

Accessories

Pages	
MIXO Frames	
Metal frames for HNM modular units	1.62
Thermoplastic docking frames	1.65-68

Can be used in bulkhead mounting housings or in high construction housings or in high construction hoods.



CX 3/4 XD inserts max. current load derating diagram

CX 03 4B HNM (High Number of Mating cycles)

40 A 500 V

 size **1 module**
3 poles
Crimp connection

EN 61984 rating	40 A 500 V 6 kV 3
Rated voltage (UL / CSA)	600 V
Insulation resistance	≥ 10 GΩ
Contact resistance	≤ 0,3 mΩ
Ambient temperature limit	-40 °C ... +125 °C
Mechanical life (cycles)	≥ 10 000

(pending: CQC)

ECBT2.E115072 | ECBT8.E115072

Item	Description	Part No.	Dimension
	Male inserts for male contacts Without contacts (to be ordered separately)	CX 03 4BM	
	Female inserts for female contacts Without contacts (to be ordered separately)	CX 03 4BF	

40 A HNM crimp contacts		Male	Female	
section (mm ²)	section (AWG)			
1,5	16	RXM2D 1.5	RXF2D 1.5	
2,5	14	RXM2D 2.5	RXF2D 2.5	
4	12	RXM2D 4.0	RXF2D 4.0	
6	10	RXM2D 6.0	RXF2D 6.0	
10	8	RXM2D 10	RXF2D 10	

Wiring information, RX contacts

conductor section (mm ²)	conductor slot ø A (mm)	stripping length B (mm)
1,5	1,8	9
2,5	2,2	9
4	2,85	9,6
6	3,5	9,6
10	4,3	15

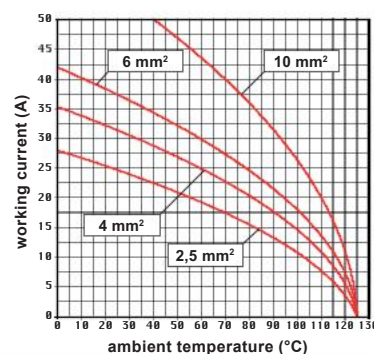
Wire diameter: up to 7 mm

 It is recommended to use the crimping tools and removal tools homologated by ILME (please see page [E.23](#))

Materials

Insert	polycarbonate (PC)
UL 94 flame rating	V-0
Colour	pebble grey, RAL 7032
Contacts	copper alloy, gold plated (HNM version)

Accessories	Pages
MIXO Frames	
Metal frames for HNM modular units	1.62
Thermoplastic docking frames	1.65-68


CX 03 4B inserts max. current load derating diagram

Can be used in bulkhead mounting housings or in high construction housings or in high construction hoods.

CX 03 4 HNM (High Number of Mating cycles)

40 A 400/690 V

size **1 module**
3 poles


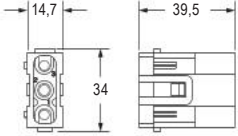

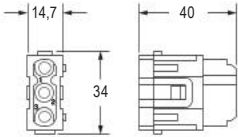
Crimp connection

EN 61984 rating	40 A 400 / 690 V 6 kV 3
Rated voltage (UL / CSA)	600 V
Insulation resistance	≥ 10 GΩ
Contact resistance	≤ 0,3 mΩ
Ambient temperature limit	-40 °C ... +125 °C
Mechanical life (cycles)	≥ 10 000

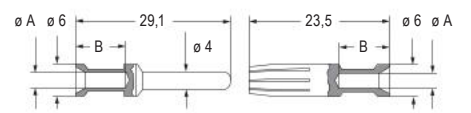


DNV VERITAS (pending: CQC)

CECUS ECBT2.E115072 | ECBT8.E115072

Item	Description	Part No.	Dimension
	Male inserts for male contacts Without contacts (to be ordered separately)	CX 03 4M	
	Female inserts for female contacts Without contacts (to be ordered separately)	CX 03 4F	

40 A HNM crimp contacts		Male	Female
section (mm ²)	section (AWG)		
1,5	16	RXM2D 1.5	RXF2D 1.5
2,5	14	RXM2D 2.5	RXF2D 2.5
4	12	RXM2D 4.0	RXF2D 4.0
6	10	RXM2D 6.0	RXF2D 6.0



Wiring information, RX contacts

conductor section (mm ²)	conductor slot ø A (mm)	stripping length B (mm)
1,5	1,8	9
2,5	2,2	9
4	2,85	9,6
6	3,5	9,6

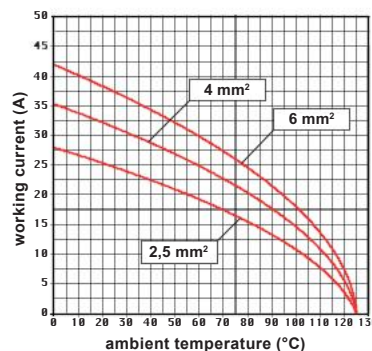
Wire diameter: up to 5,3 mm

It is recommended to use the crimping tools and removal tools homologated by ILME (please see page [E.23](#))

Materials

Insert	polycarbonate (PC)
UL 94 flame rating	V-0
Colour	pebble grey, RAL 7032
Contacts	copper alloy, gold plated (HNM version)

Accessories	Pages
MIXO Frames	
Metal frames for HNM modular units	1.62
Thermoplastic docking frames	1.65-68



CX 03 4 inserts max. current load derating diagram

CX 06P C HNM (High Number of Mating cycles)

16 A 830 V

size **1 module**

6 poles protected


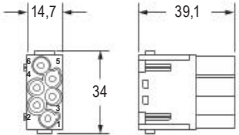
Crimp connection

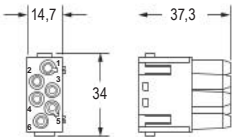
EN 61984 rating	16 A 830 V 8 kV 3
Rated voltage (UL / CSA)	600 V
Insulation resistance	≥ 10 GΩ
Contact resistance	≤ 1 mΩ
Ambient temperature limit	-40 °C ... +125 °C
Mechanical life (cycles)	≥ 10 000

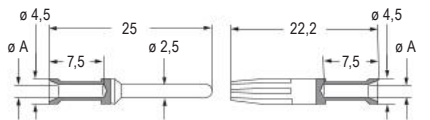
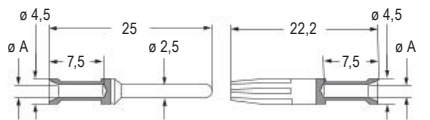
CE UK EAC

DNV VERITAS (pending: CQC)

CAIUS ECBT2.E115072 | ECBT8.E115072

Item	Description	Part No.	Dimension
	Male inserts for male contacts Without contacts (to be ordered separately) Male insert is protected from access with the back of the hand (IP1X or IPXXA)	CX 06P CM	

	Female inserts for female contacts Without contacts (to be ordered separately) Female insert is finger proof (IP2X or IPXXB) even if not coupled	CX 06P CF	
---	--	---------------------------	---

16 A HNM crimp contacts		Male	Female	
section (mm ²)	section (AWG)			
0,14-0,37	26-22	RCM2D 0.3	RCF2D 0.3	
0,5	20	RCM2D 0.5	RCF2D 0.5	
0,75	18	RCM2D 0.7	RCF2D 0.7	
1	18	RCM2D 1.0	RCF2D 1.0	
1,5	16	RCM2D 1.5	RCF2D 1.5	
2,5	14	RCM2D 2.5	RCF2D 2.5	
3	12	RCM2D 3.0	RCF2D 3.0	
4	12	RCM2D 4.0	RCF2D 4.0	


Wiring information, RC contacts

conductor section (mm ²)	conductor slot ø A (mm)	stripping length (mm)
0,14-0,37	0,9	7,5
0,5	1,1	7,5
0,75	1,3	7,5
1,0	1,45	7,5
1,5	1,8	7,5
2,5	2,2	7,5
3,0	2,55	7,5
4,0	2,85	7,5

Wire diameter: up to 4,7 mm.

It is recommended to use the crimping tools and removal tools homologated by ILME (please see page [F.23](#))

Materials

Insert	polycarbonate (PC)
UL 94 flame rating	V-0
Colour	pebble grey, RAL 7032
Contacts	copper alloy, gold  plated (HNM version)

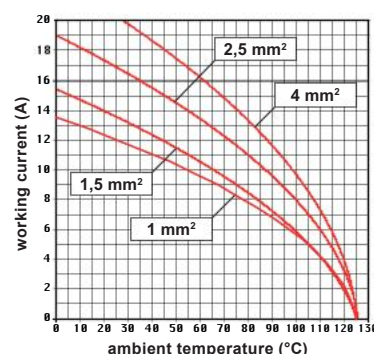


CR CPQ
Coding pins
Page [E.3](#)

Accessories

MIXO Frames

	Pages
Metal frames for HNM modular units	1.62
Thermoplastic docking frames	1.65-68



CX 06P C inserts max. current load derating diagram

It is recommended the use of **CRF CX / CRM CX** coding pins together with relevant MIXO frames.

CX 20 C HNM (High Number of Mating cycles)

16 A 500 V

size **2 modules**

20 poles

Crimp connection

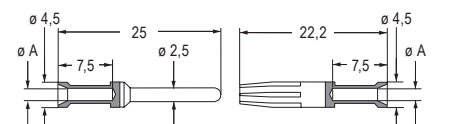
EN 61984 rating	16 A 500 V 6 kV 3
	16 A 830 V 8 kV 2
Rated voltage (UL / CSA)	600 V
Insulation resistance	≥ 10 GΩ
Contact resistance	≤ 1 mΩ
Ambient temperature limit	-40 °C ... +125 °C
Mechanical life (cycles)	≥ 10 000



ECBT2.E115072 | ECBT8.E115072

Item	Description	Part No.	Dimension
	Male inserts for male contacts Without contacts (to be ordered separately)	CX 20 CM	
	Female inserts for female contacts Without contacts (to be ordered separately)	CX 20 CF	

16 A HNM crimp contacts	section (mm ²)		Male	Female
	0,14-0,37	26-22		
0,5	20		RCM2D 0.3	RCF2D 0.3
0,75	18		RCM2D 0.5	RCF2D 0.5
1	18		RCM2D 0.7	RCF2D 0.7
1,5	16		RCM2D 1.0	RCF2D 1.0
2,5	14		RCM2D 1.5	RCF2D 1.5
3	12		RCM2D 2.5	RCF2D 2.5
4	12		RCM2D 3.0	RCF2D 3.0
			RCM2D 4.0	RCF2D 4.0



Wiring information, RC contacts

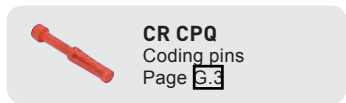
conductor section (mm ²)	conductor slot ø A (mm)	stripping length (mm)
0,14-0,37	0,9	7,5
0,5	1,1	7,5
0,75	1,3	7,5
1,0	1,45	7,5
1,5	1,8	7,5
2,5	2,2	7,5
3,0	2,55	7,5
4,0	2,85	7,5

Wire diameter: up to 4,7 mm.

It is recommended to use the crimping tools and removal tools homologated by ILME (please see page [E.23](#))

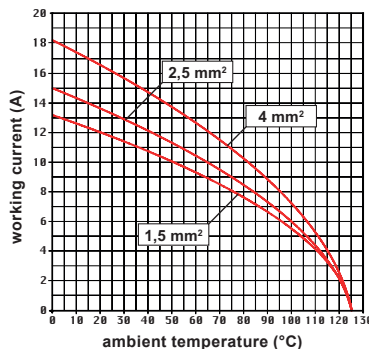
Materials

Insert	polycarbonate (PC)
UL 94 flame rating	V-0
Colour	pebble grey, RAL 7032
Contacts	copper alloy, gold ● plated (HNM version)



Accessories

	Pages
MIXO Frames	
Metal frames for HNM modular units	1.62
Thermoplastic docking frames	1.65-68



CX 20 C inserts max. current load derating diagram

On request, wiring with 3 fastened **CX 20 CM/CF** inserts with poles numbered from 1-60 references: **CX 60 CM** and **CX 60 CF**

CX 06 C HNM (High Number of Mating cycles)

16 A 500 V

size **1 module**
6 poles

Crimp connection

EN 61984 rating	16 A 500 V 6 kV 3
	16 A 400 / 690 V 6 kV 2
Rated voltage (UL / CSA)	600 V
Insulation resistance	≥ 10 GΩ
Contact resistance	≤ 1 mΩ
Ambient temperature limit	-40 °C ... +125 °C
Mechanical life (cycles)	≥ 10 000



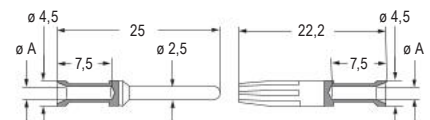
DNV VERITAS (pending: CQC)

CAIUS ECBT2.E115072 | ECBT8.E115072

Item	Description	Part No.	Dimension
	Male inserts for male contacts Without contacts (to be ordered separately)	CX 06 CM	
	Female inserts for female contacts Without contacts (to be ordered separately)	CX 06 CF	

16 A HNM crimp contacts	section (mm ²)		section (AWG)		Male	Female
		0,14-0,37	0,5	26-22		
	0,5	0,75	20			
	0,75	1	18			
	1	1,5	18			
	1,5	2,5	16			
	2,5	3	14			
	3	4	12			
	4		12			

Male	Female
RCM2D 0.3	RCF2D 0.3
RCM2D 0.5	RCF2D 0.5
RCM2D 0.7	RCF2D 0.7
RCM2D 1.0	RCF2D 1.0
RCM2D 1.5	RCF2D 1.5
RCM2D 2.5	RCF2D 2.5
RCM2D 3.0	RCF2D 3.0
RCM2D 4.0	RCF2D 4.0




Wiring information, RC contacts

conductor section (mm ²)	conductor slot ø A (mm)	stripping length (mm)
0,14-0,37	0,9	7,5
0,5	1,1	7,5
0,75	1,3	7,5
1,0	1,45	7,5
1,5	1,8	7,5
2,5	2,2	7,5
3,0	2,55	7,5
4,0	2,85	7,5

Wire diameter: up to 4,7 mm.

It is recommended to use the crimping tools and removal tools homologated by ILME (please see page [F.23](#))

Materials

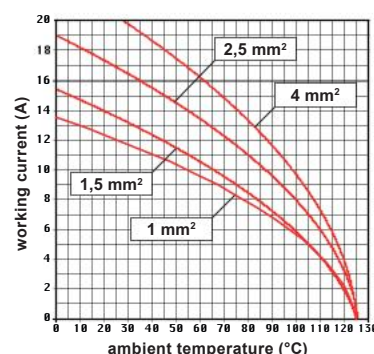
Insert	polycarbonate (PC)
UL 94 flame rating	V-0
Colour	pebble grey, RAL 7032
Contacts	copper alloy, gold  plated (HNM version)



CR CPQ
Coding pins
Page [E.3](#)

Accessories

	Pages
MIXO Frames	
Metal frames for HNM modular units	1.62
Thermoplastic docking frames	1.65-68



CX 06 C inserts max. current load derating diagram



CX 08 C HNM (High Number of Mating cycles)

16 A 400 V

size **1 module**

8 poles


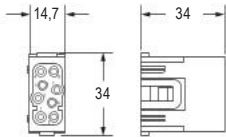

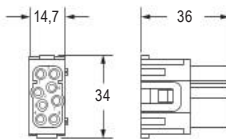
Crimp connection

EN 61984 rating	16 A 500 V 6 kV 3
	16 A 400 / 690 V 6 kV 2
Rated voltage (UL / CSA)	600 V
Insulation resistance	≥ 10 GΩ
Contact resistance	≤ 1 mΩ
Ambient temperature limit	-40 °C ... +125 °C
Mechanical life (cycles)	≥ 10 000

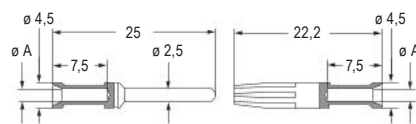


DNV VERITAS (pending: CQC)

CEC US ECBT2.E115072 | ECBT8.E115072

Item	Description	Part No.	Dimension
	Male inserts for male contacts Without contacts (to be ordered separately)	CX 08 CM	
	Female inserts for female contacts Without contacts (to be ordered separately)	CX 08 CF	

16 A HNM crimp contacts		Male	Female
section (mm ²)	section (AWG)		
0,14-0,37	26-22	RCM2D 0.3	RCF2D 0.3
0,5	20	RCM2D 0.5	RCF2D 0.5
0,75	18	RCM2D 0.7	RCF2D 0.7
1	18	RCM2D 1.0	RCF2D 1.0
1,5	16	RCM2D 1.5	RCF2D 1.5
2,5	14	RCM2D 2.5	RCF2D 2.5
3	12	RCM2D 3.0	RCF2D 3.0
4	12	RCM2D 4.0	RCF2D 4.0



Wiring information, RC contacts

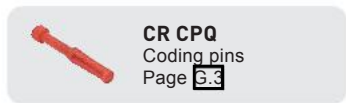
conductor section (mm ²)	conductor slot ø A (mm)	stripping length (mm)
0,14-0,37	0,9	7,5
0,5	1,1	7,5
0,75	1,3	7,5
1,0	1,45	7,5
1,5	1,8	7,5
2,5	2,2	7,5
3,0	2,55	7,5
4,0	2,85	7,5

Wire diameter: up to 4,7 mm.

It is recommended to use the crimping tools and removal tools homologated by ILME (please see page [E.23](#))

Materials

Insert	polycarbonate (PC)
UL 94 flame rating	V-0
Colour	pebble grey, RAL 7032
Contacts	copper alloy, gold ● plated (HNM version)

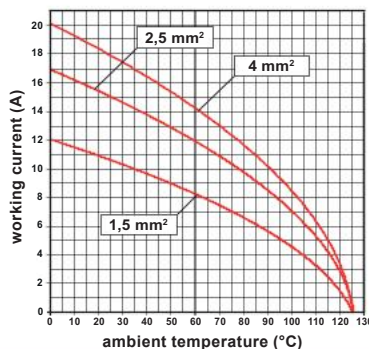


CR CPQ
Coding pins
Page [E.3](#)

Accessories

Pages

Accessories	Pages
MIXO Frames	
Metal frames for HNM modular units	1.62
Thermoplastic docking frames	1.65-68



CX 08 C inserts max. current load derating diagram

CX
H

CX 12 D HNM (High Number of Mating cycles)

10 A 250 V

size **1 module**

12 poles


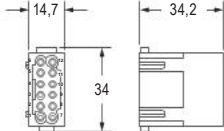

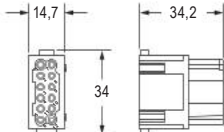
Crimp connection

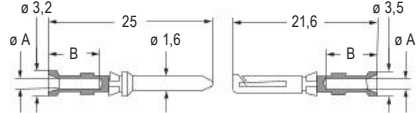
EN 61984 rating	10 A 250 V 4 kV 3
Rated voltage (UL / CSA)	600 V
Insulation resistance	≥ 10 GΩ
Contact resistance	≤ 3 mΩ
Ambient temperature limit	-40 °C ... +125 °C
Mechanical life (cycles)	≥ 10 000

CE UK EAC

DNV VERITAS (pending: CQC)

CAIUS ECBT2.E115072 | ECBT8.E115072

Item	Description	Part No.	Dimension
	Male inserts for male contacts Without contacts (to be ordered separately)	CX 12 DM	
	Female inserts for female contacts Without contacts (to be ordered separately)	CX 12 DF	

10 A HNM crimp contacts		Male	Female	
section (mm ²)	section (AWG)			
0,14-0,37	26-22	RDM2D 0.3	RDF2D 0.3	
0,5	20	RDM2D 0.5	RDF2D 0.5	
0,75	18	RDM2D 0.7	RDF2D 0.7	
1	18	RDM2D 1.0	RDF2D 1.0	
1,5	16	RDM2D 1.5	RDF2D 1.5	
2,5	14	RDM2D 2.5	RDF2D 2.5	


Wiring information, RD contacts

conductor section (mm ²)	conductor slot ø A (mm)	stripping length B (mm)
0,14-0,37	0,9	8
0,5	1,1	8
0,75	1,3	8
1,0	1,45	8
1,5	1,8	8
2,5	2,2	6

Wire diameter: up to 3,8 mm.

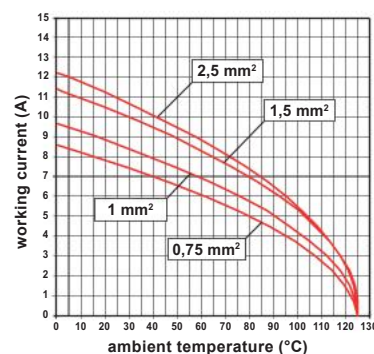
It is recommended to use the crimping tools and removal tools homologated by ILME (please see page [F.23](#))

Materials

Insert	polycarbonate (PC)
UL 94 flame rating	V-0
Colour	pebble grey, RAL 7032
Contacts	copper alloy, gold  plated (HNM version)

Accessories

	Pages
MIXO Frames	
Metal frames for HNM modular units	1.62
Thermoplastic docking frames	1.65-68



CX 12 D inserts max. current load derating diagram

CX 17 D HNM (High Number of Mating cycles)

10 A 160 V

size **1 module**

17 poles


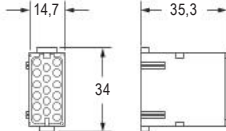

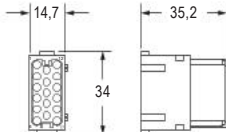
Crimp connection

EN 61984 rating	10 A 160 V 2,5 kV 3
	10 A 250 V 4 kV 2
Rated voltage (UL / CSA)	250 V
Insulation resistance	≥ 10 GΩ
Contact resistance	≤ 3 mΩ
Ambient temperature limit	-40 °C ... +125 °C
Mechanical life (cycles)	≥ 10 000

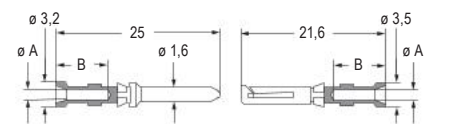
CE UK EAC

DNV VERITAS (pending: CQC)

CEC US ECBT2.E115072 | ECBT8.E115072

Item	Description	Part No.	Dimension
	Male inserts for male contacts Without contacts (to be ordered separately)	CX 17 DM	
	Female inserts for female contacts Without contacts (to be ordered separately)	CX 17 DF	

10 A HNM crimp contacts		Male	Female
section (mm ²)	section (AWG)		
0,14-0,37	26-22	RDM2D 0.3	RDF2D 0.3
0,5	20	RDM2D 0.5	RDF2D 0.5
0,75	18	RDM2D 0.7	RDF2D 0.7
1	18	RDM2D 1.0	RDF2D 1.0
1,5	16	RDM2D 1.5	RDF2D 1.5
2,5	14	RDM2D 2.5	RDF2D 2.5




Wiring information, RD contacts

conductor section (mm ²)	conductor slot ø A (mm)	stripping length B (mm)
0,14-0,37	0,9	8
0,5	1,1	8
0,75	1,3	8
1,0	1,45	8
1,5	1,8	8
2,5	2,2	6

Wire diameter: up to 3,8 mm.

It is recommended to use the crimping tools and removal tools homologated by ILME (please see page [F.23](#))

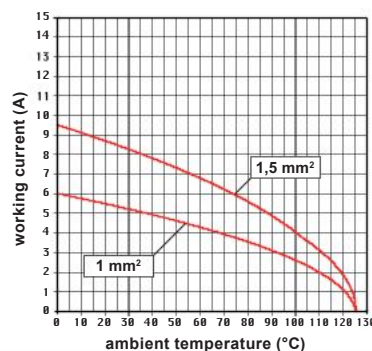
Materials

Insert	polycarbonate (PC)
UL 94 flame rating	V-0
Colour	pebble grey, RAL 7032
Contacts	copper alloy, gold  plated (HNM version)

Accessories

	Pages
MIXO Frames	
Metal frames for HNM modular units	1.62
Thermoplastic docking frames	1.65-68

Can be used in bulkhead mounting housings or in high construction housings or in high construction hoods.



CX 17 D inserts max. current load derating diagram

CX 42 D HNM (High Number of Mating cycles)

10 A 150 V

size **2 modules**

42 poles


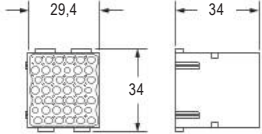
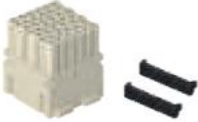
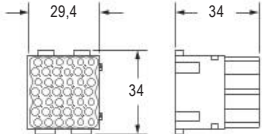

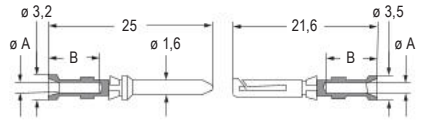
Crimp connection

EN 61984 rating	10 A 150 V 2,5 kV 3
Rated voltage (UL / CSA)	250 V
Insulation resistance	≥ 10 GΩ
Contact resistance	≤ 3 mΩ
Ambient temperature limit	-40 °C ... +125 °C
Mechanical life (cycles)	≥ 10 000

CE UK EAC

DNV VERITAS (pending: CQC)

CAIUS ECBT2.E115072 | ECBT8.E115072

Item	Description	Part No.	Dimension																												
	Male inserts for male contacts Without contacts (to be ordered separately) Supplied with 2 dedicated black coloured 2-slot sized lock-in tab. For spare lock-in tab CX CFMD see SPARE PARTS catalogue	CX 42 DM																													
	Female inserts for female contacts Without contacts (to be ordered separately) Supplied with 2 dedicated black coloured 2-slot sized lock-in tab. For spare lock-in tab CX CFMD see SPARE PARTS catalogue	CX 42 DF																													
	10 A HNM crimp contacts <table border="1"> <thead> <tr> <th>section (mm²)</th> <th>section (AWG)</th> </tr> </thead> <tbody> <tr><td>0,14-0,37</td><td>26-22</td></tr> <tr><td>0,5</td><td>20</td></tr> <tr><td>0,75</td><td>18</td></tr> <tr><td>1</td><td>18</td></tr> <tr><td>1,5</td><td>16</td></tr> <tr><td>2,5</td><td>14</td></tr> </tbody> </table>	section (mm ²)	section (AWG)	0,14-0,37	26-22	0,5	20	0,75	18	1	18	1,5	16	2,5	14	<table border="1"> <thead> <tr> <th>Male</th> <th>Female</th> </tr> </thead> <tbody> <tr><td>RDM2D 0.3</td><td>RDF2D 0.3</td></tr> <tr><td>RDM2D 0.5</td><td>RDF2D 0.5</td></tr> <tr><td>RDM2D 0.7</td><td>RDF2D 0.7</td></tr> <tr><td>RDM2D 1.0</td><td>RDF2D 1.0</td></tr> <tr><td>RDM2D 1.5</td><td>RDF2D 1.5</td></tr> <tr><td>RDM2D 2.5</td><td>RDF2D 2.5</td></tr> </tbody> </table>	Male	Female	RDM2D 0.3	RDF2D 0.3	RDM2D 0.5	RDF2D 0.5	RDM2D 0.7	RDF2D 0.7	RDM2D 1.0	RDF2D 1.0	RDM2D 1.5	RDF2D 1.5	RDM2D 2.5	RDF2D 2.5	
section (mm ²)	section (AWG)																														
0,14-0,37	26-22																														
0,5	20																														
0,75	18																														
1	18																														
1,5	16																														
2,5	14																														
Male	Female																														
RDM2D 0.3	RDF2D 0.3																														
RDM2D 0.5	RDF2D 0.5																														
RDM2D 0.7	RDF2D 0.7																														
RDM2D 1.0	RDF2D 1.0																														
RDM2D 1.5	RDF2D 1.5																														
RDM2D 2.5	RDF2D 2.5																														

Wiring information, RD contacts

conductor section (mm ²)	conductor slot ø A (mm)	stripping length B (mm)
0,14-0,37	0,9	8
0,5	1,1	8
0,75	1,3	8
1,0	1,45	8
1,5	1,8	8
2,5	2,2	6

Wire diameter: up to 3,6 mm.

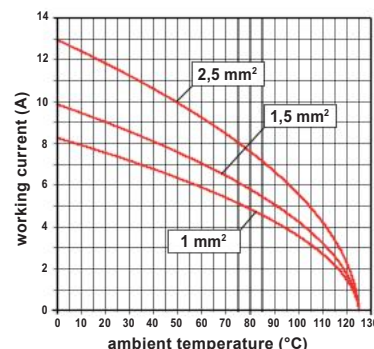
It is recommended to use the crimping tools and removal tools homologated by ILME (please see page [F.23](#))

Materials

Insert	polycarbonate (PC)
UL 94 flame rating	V-0
Colour	pebble grey, RAL 7032
Contacts	copper alloy, gold ● plated (HNM version)

Accessories

	Pages
MIXO Frames	
Metal frames for HNM modular units	1.62
Thermoplastic docking frames	1.65-68



CX 42 D inserts max. current load derating diagram

Can be used in bulkhead mounting housings or in high construction housings or in high construction hoods.

CX 25 IB HNM (High Number of Mating cycles)

4 A 50 V

size **1 module**

25 poles

Crimp connection

EN 61984 rating	4 A 50 V 0,8 kV 3
	4 A 160 V 2,5 kV 2
Rated voltage (UL / CSA)	600 V
Insulation resistance	≥ 10 GΩ
Contact resistance	≤ 4 mΩ
Ambient temperature limit	-40 °C ... +125 °C
Mechanical life (cycles)	≥ 10 000



CEC® ECBT2.E115072 | ECBT8.E115072

Item	Description	Part No.	Dimension																				
	Male inserts for male contacts Without contacts (to be ordered separately)	CX 25 IBM																					
	Female inserts for female contacts Without contacts (to be ordered separately)	CX 25 IBF																					
	5 A HNM crimp contacts <table border="1"> <tr> <th>section (mm²)</th> <th>section (AWG)</th> </tr> <tr> <td>0,08-0,21</td> <td>28-24</td> </tr> <tr> <td>0,13-0,33</td> <td>26-22</td> </tr> <tr> <td>0,33-0,52</td> <td>22-20</td> </tr> <tr> <td>0,52-0,75</td> <td>20-18</td> </tr> </table>	section (mm ²)	section (AWG)	0,08-0,21	28-24	0,13-0,33	26-22	0,33-0,52	22-20	0,52-0,75	20-18	<table border="1"> <tr> <th>Male</th> <th>Female</th> </tr> <tr> <td>RIMD 0.2</td> <td>RIFD 0.2</td> </tr> <tr> <td>RIMD 0.3</td> <td>RIFD 0.3</td> </tr> <tr> <td>RIMD 0.5</td> <td>RIFD 0.5</td> </tr> <tr> <td>RIMD 0.7</td> <td>RIFD 0.7</td> </tr> </table>	Male	Female	RIMD 0.2	RIFD 0.2	RIMD 0.3	RIFD 0.3	RIMD 0.5	RIFD 0.5	RIMD 0.7	RIFD 0.7	
section (mm ²)	section (AWG)																						
0,08-0,21	28-24																						
0,13-0,33	26-22																						
0,33-0,52	22-20																						
0,52-0,75	20-18																						
Male	Female																						
RIMD 0.2	RIFD 0.2																						
RIMD 0.3	RIFD 0.3																						
RIMD 0.5	RIFD 0.5																						
RIMD 0.7	RIFD 0.7																						

Wiring information, RI contacts

conductor section (mm ²)	conductor slot ø A (mm)	stripping length (mm)
0,08-0,21	0,64	4
0,13-0,33	0,9	4
0,33-0,52	1,12	4
0,52-0,75	1,30	4

Wire diameter: up to 2,1 mm.

It is recommended to use the crimping tools and removal tools homologated by ILME (please see page [E.23](#))

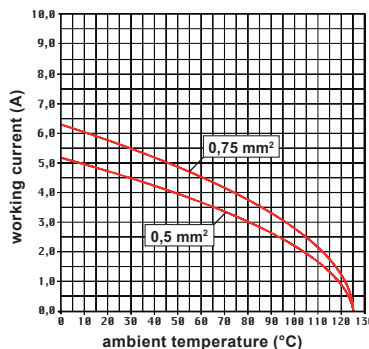
Materials

Insert	polycarbonate (PC)
UL 94 flame rating	V-0
Colour	pebble grey, RAL 7032
Contacts	copper alloy, gold plated (HNM version)

Accessories

Pages

MIXO Frames	
Metal frames for HNM modular units	1.62
Thermoplastic docking frames	1.65-68



CX 25 IB inserts max. current load derating diagram

It is recommended the use of **CRF CX / CRM CX** coding pins together with relevant MIXO frames.

CX 36 I HNM (High Number of Mating cycles)

4 A 32 V

size **1 module**


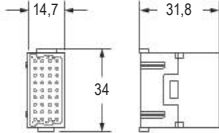

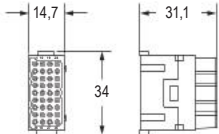

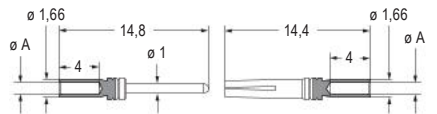
36 poles

Crimp connection

EN 61984 rating	4 A 32 V 0,8 kV 3
Rated voltage (UL / CSA)	30 V
Insulation resistance	≥ 10 GΩ
Contact resistance	≤ 4 mΩ
Ambient temperature limit	-40 °C ... +125 °C
Mechanical life (cycles)	≥ 10 000



CAIUS ECBT2.E115072 | ECBT8.E115072


Item	Description	Part No.	Dimension																				
	Male inserts for male contacts Without contacts (to be ordered separately)	CX 36 IM																					
	Female inserts for female contacts Without contacts (to be ordered separately)	CX 36 IF																					
	5 A HNM crimp contacts <table border="1"> <thead> <tr> <th>section (mm²)</th> <th>section (AWG)</th> </tr> </thead> <tbody> <tr> <td>0,08-0,21</td> <td>28-24</td> </tr> <tr> <td>0,13-0,33</td> <td>26-22</td> </tr> <tr> <td>0,33-0,52</td> <td>22-20</td> </tr> </tbody> </table>	section (mm ²)	section (AWG)	0,08-0,21	28-24	0,13-0,33	26-22	0,33-0,52	22-20	<table border="1"> <thead> <tr> <th></th> <th>Male</th> <th>Female</th> </tr> </thead> <tbody> <tr> <td>gold</td> <td>RIMD 0.2</td> <td>RIFD 0.2</td> </tr> <tr> <td></td> <td>RIMD 0.3</td> <td>RIFD 0.3</td> </tr> <tr> <td></td> <td>RIMD 0.5</td> <td>RIFD 0.5</td> </tr> </tbody> </table>		Male	Female	gold	RIMD 0.2	RIFD 0.2		RIMD 0.3	RIFD 0.3		RIMD 0.5	RIFD 0.5	
section (mm ²)	section (AWG)																						
0,08-0,21	28-24																						
0,13-0,33	26-22																						
0,33-0,52	22-20																						
	Male	Female																					
gold	RIMD 0.2	RIFD 0.2																					
	RIMD 0.3	RIFD 0.3																					
	RIMD 0.5	RIFD 0.5																					

Wiring information, RI contacts

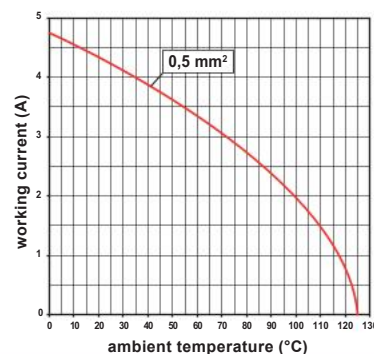
conductor section (mm ²)	conductor slot ø A (mm)	stripping length (mm)
0,08-0,21	0,64	4
0,13-0,33	0,9	4
0,33-0,52	1,12	4

Wire diameter: up to 1,7 mm.

It is recommended to use the crimping tools and removal tools homologated by ILME (please see page [E.23](#))

Materials	
Insert	polycarbonate (PC)
UL 94 flame rating	V-0
Colour	pebble grey, RAL 7032
Contacts	copper alloy, gold  plated (HNM version)

Accessories	Pages
MIXO Frames	
Metal frames for HNM modular units	1.62
Thermoplastic docking frames	1.65-68



CX 36 I inserts max. current load derating diagram

RX 08 D5 / RX 08 D5G

HNM (High Number of Mating cycles)

size **1 module**

10 A 50 V

8 poles + shield connection

Crimp connection

EN 61984 rating	10 A 50 V 0,8 kV 3
Rated voltage (UL / CSA)	50 V
Insulation resistance	≥ 10 GΩ
Contact resistance	≤ 3 mΩ
Ambient temperature limit	-40 °C ... +85 °C
Mechanical life (cycles)	≥ 10 000



ILME ECBT2.E115072 | ECBT8.E115072

Item	Description	Part No.	Dimension
	Male inserts, single cable entry	RX 08 D5M	
	Male inserts, double cable entry (contacts to be ordered separately)	RX 08 D5M2	
	Shield electrically separated from PE circuit MIXO frame		
	Female inserts, single cable entry	RX 08 D5F	
	Female inserts, double cable entry (contacts to be ordered separately)	RX 08 D5F2	
	Shield electrically separated from PE circuit MIXO frame		
	Male inserts, single cable entry	RX 08 D5GM	
	Male inserts, double cable entry (contacts to be ordered separately)	RX 08 D5GM2	
	Shield electrically in contact with PE circuit MIXO frame by dual stainless steel springs on the insert		
	Female inserts, single cable entry	RX 08 D5GF	
	Female inserts, double cable entry (contacts to be ordered separately)	RX 08 D5GF2	
	Shield electrically in contact with PE circuit MIXO frame by dual stainless steel springs on the insert		
	10 A HNM crimp contacts	Male	Female
	section (mm ²)		
	section (AWG)		
	0,14-0,37	RDM2D 0.3	RDF2D 0.3
	0,5	RDM2D 0.5	RDF2D 0.5
	0,75	RDM2D 0.7	RDF2D 0.7
	1	RDM2D 1.0	RDF2D 1.0
	1,5	RDM2D 1.5	RDF2D 1.5
	2,5	RDM2D 2.5	RDF2D 2.5
	Wire diameter: up to 3,8 mm.		
	It is recommended to use the crimping tools and removal tools homologated by ILME (please see page F.23)		
		Wiring information, RD contacts	
	conductor section (mm ²)	conductor slot ø A (mm)	stripping length B (mm)
	0,14-0,37	0,9	8
	0,5	1,1	8
	0,75	1,3	8
	1,0	1,45	8
	1,5	1,8	8
	2,5	2,2	6

Materials	
Insert	polycarbonate (PC)
UL 94 flame rating	V-0
Colour	pebble grey, RAL 7032
Contacts	copper alloy, gold ● plated (HNM version)

Accessories	Pages
MIXO Frames	
Metal frames for HNM modular units	F.62
Thermoplastic docking frames	F.65-68

	CX..CA Cable clamps Page F.56		CX..CF Crimp flanges (1) Page E.28		CX..S Crimp sleeves (1) Page E.29
--	--	--	---	--	--

(1) Upon request we can supply crimp flanges (code CX..CF) and crimp sleeves (code CX..S) of different diameters that must be chosen according to the specific cable shield and insulation diameter. Please contact ILME Commercial Offices.

Megabit Ethernet Cat 5, Class D up to 100 Mhz and up to 100 Mbit/s.

It is recommended the use of CRF CX / CRM CX coding pins together with relevant MIXO frames.

RX 08 I6 / RX 08 I6G HNM (High Number of Mating cycles)

5 A 50 V

 size **1 module**
8 poles + shield connection

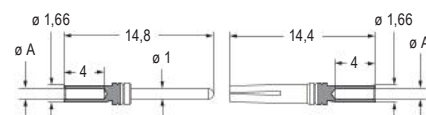
Crimp connection

EN 61984 rating	5 A 50 V 0,8 kV 3
Rated voltage (UL / CSA)	50 V
Insulation resistance	≥ 10 GΩ
Contact resistance	≤ 4 mΩ
Ambient temperature limit	-40 °C ... +85 °C
Mechanical life (cycles)	≥ 10 000



ECBT2.E115072 | ECBT8.E115072

Item	Description	Part No.	Dimension
	Male inserts for male contacts Without contacts (to be ordered separately) Shield electrically separated from PE circuit MIXO frame	RX 08 I6M	
	Female inserts for female contacts Without contacts (to be ordered separately) Shield electrically separated from PE circuit MIXO frame	RX 08 I6F	
	Male inserts for male contacts Without contacts (to be ordered separately) Shield electrically in contact with PE circuit MIXO frame by dual stainless steel springs on the insert	RX 08 I6GM	
	Female inserts for female contacts Without contacts (to be ordered separately) Shield electrically in contact with PE circuit MIXO frame by dual stainless steel springs on the insert	RX 08 I6GF	
	5 A HNM crimp contacts section (mm ²) section (AWG) 0,08-0,21 28-24 0,13-0,33 26-22 0,33-0,52 22-20	Male gold RIMD 0.2 RIMD 0.3 RIMD 0.5	Female RIFD 0.2 RIFD 0.3 RIFD 0.5



Wiring information, RI contacts

conductor section (mm ²)	conductor slot ϕA (mm)	stripping length (mm)
0,08-0,21	0,64	4
0,13-0,33	0,9	4
0,33-0,52	1,12	4

Wire diameter: up to 1,7 mm.

 For basic or high thickness gold plating, please refer to page [F.17](#)
It is recommended to use the crimping tools and removal tools homologated by ILME (please see page [F.23](#))

Materials

Insert	polycarbonate (PC)
UL 94 flame rating	V-0
Colour	pebble grey, RAL 7032
Contacts	copper alloy, gold plated (HNM version)

Accessories

Pages

MIXO Frames

Metal frames for HNM modular units	F.62
Thermoplastic docking frames	F.65-68


CX..CA
 Cable clamps
 Page [F.56](#)

CX..CF
 Crimp flanges (1)
 Page [G.28](#)

CX..S
 Crimp sleeves (1)
 Page [G.29](#)

 (1) Upon request we can supply crimp flanges (code **CX..CF**) and crimp sleeves (code **CX..S**) of different diameters that must be chosen according to the specific cable shield and insulation diameter. Please contact ILME Commercial Offices.

 Gigabit Ethernet Cat 6_A, Class E_A up to 500 Mhz and up to 10 Gbit/s.

 It is recommended the use of **CRF CX / CRM CX** coding pins together with relevant MIXO frames.

RX 20S I / RX 20S IG HNM (High Number of Mating cycles)

4 A 32 V

size **1 module**

20 poles + shield connection

Crimp connection

EN 61984 rating	4 A 32 V 0,8 kV 3
Rated voltage (UL / CSA)	32 V
Insulation resistance	≥ 10 GΩ
Contact resistance	≤ 4 mΩ
Ambient temperature limit	-40 °C ... +85 °C
Mechanical life (cycles)	≥ 10 000



ILME ECBT2.E115072 | ECBT8.E115072

Item	Description	Part No.	Dimension	
	Male inserts for male contacts Without contacts (to be ordered separately) Shield electrically separated from PE circuit MIXO frame	RX 20S IM		
	Female inserts for female contacts Without contacts (to be ordered separately) Shield electrically separated from PE circuit MIXO frame	RX 20S IF		
	Male inserts for male contacts Without contacts (to be ordered separately) Shield electrically in contact with PE circuit MIXO frame by dual stainless steel springs on the insert	RX 20S IGM		
	Female inserts for female contacts Without contacts (to be ordered separately) Shield electrically in contact with PE circuit MIXO frame by dual stainless steel springs on the insert	RX 20S IGF		
	5 A HNM crimp contacts section (mm ²) section (AWG) 0,08-0,21 28-24 0,13-0,33 26-22 0,33-0,52 22-20	Male RIMD 0.2 RIMD 0.3 RIMD 0.5	Female RIFD 0.2 RIFD 0.3 RIFD 0.5	

Wiring information, RI contacts

conductor section (mm ²)	conductor slot ø A (mm)	stripping length (mm)
0,08-0,21	0,64	4
0,13-0,33	0,9	4
0,33-0,52	1,12	4

Wire diameter: up to 1,9 mm.

For basic or high thickness gold plating, please refer to page [F.17](#)

It is recommended to use the crimping tools and removal tools homologated by ILME (please see page [F.23](#))

Materials

Insert	polycarbonate (PC)
UL 94 flame rating	V-0
Colour	pebble grey, RAL 7032
Contacts	copper alloy, gold ● plated (HNM version)

Accessories

Pages

MIXO Frames	
Metal frames for HNM modular units	F.62
Thermoplastic docking frames	F.65-68


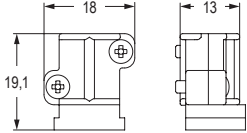

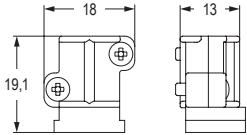

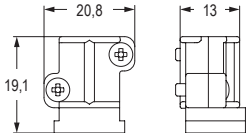

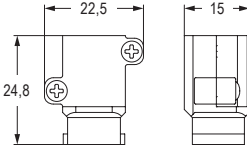
CX..CA Cable clamps Page F.56	CX..CF Crimp flanges (1) Page G.28	CX..S Crimp sleeves (1) Page G.29
--	---	--

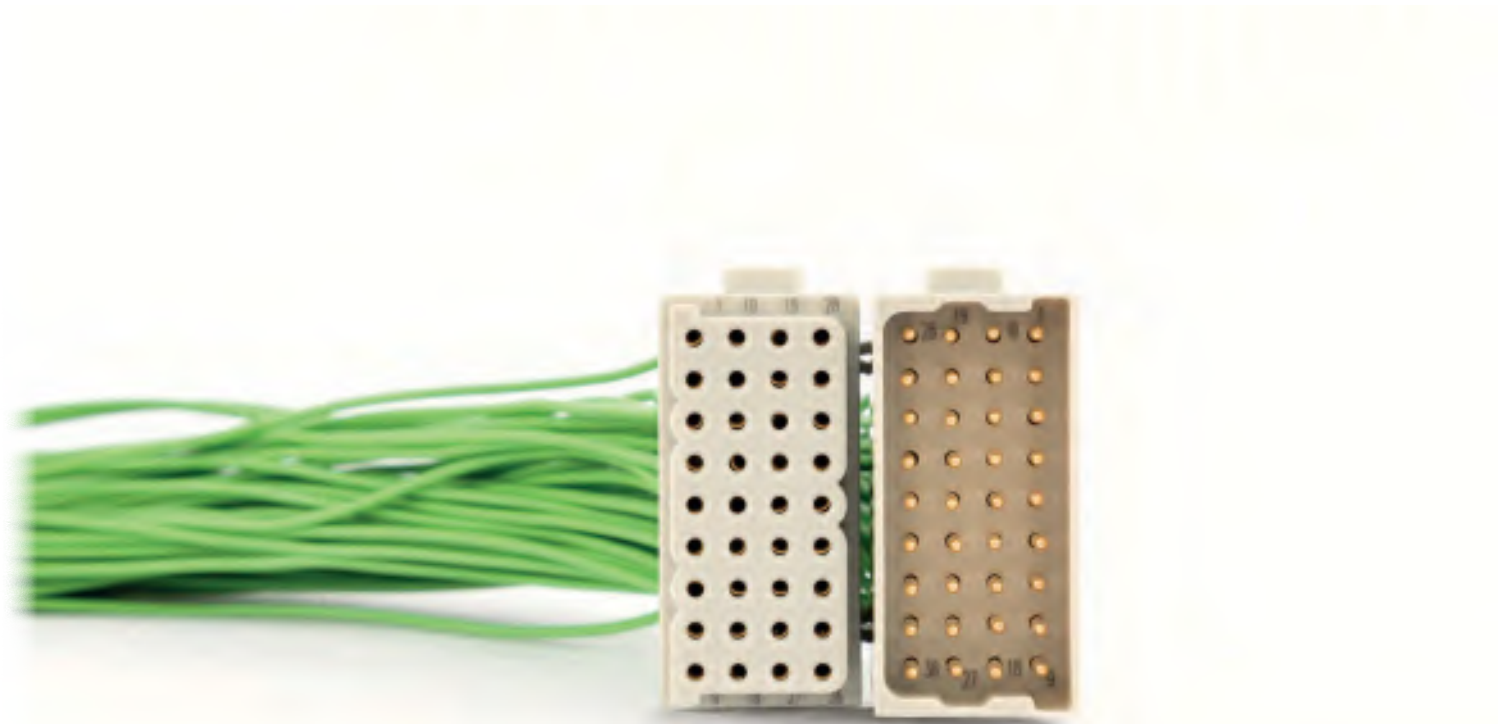
(1) Upon request we can supply crimp flanges (code **CX..CF**) and crimp sleeves (code **CX..S**) of different diameters that must be chosen according to the specific cable shield and insulation diameter. Please contact ILME Commercial Offices.

It is recommended the use of **CRF CX / CRM CX** coding pins together with relevant MIXO frames.

CX..CA

Cable clamps for MIX0 Megabit /Gigabit /Shielded

Item	Description	Part No.	Dimension
	Cable clamp for 5-7 mm cable diameter Crimp flanges and sleeves supplied upon request	CX 5/7 CA	
	Cable clamp for 7-10 mm cable diameter Crimp flanges and sleeves supplied upon request	CX 7/10 CA	
	Cable clamp for 10-12 mm cable diameter Can't be used with CX 08 D5F/M2/D5GF/M2 and RX 08 D5F/M2/D5GF/M2 HNM modular units. Crimp flanges and sleeves supplied upon request	CX 10/12 CA	
	Cable clamp for 11-14 mm cable diameter Can't be used with CX 08 D5F/M2/D5GF/M2 and RX 08 D5F/M2/D5GF/M2 HNM modular units. Crimp flanges and sleeves supplied upon request	CX 11/14 CA	



CX 03 MP HNM (High Number of Mating cycles)


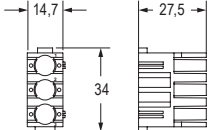
 size **1 module**

Inserts for metal pneumatic contacts

Insulation resistance	≥ 10 GΩ
Ambient temperature limit	-40 °C ... +80 °C
Mechanical life (cycles)	≥ 10 000



(pending: cURus)

Item	Description	Part No.	Dimension
	Inserts with 3 housings for tube Ø 3 - 4 - 6 mm Without contacts (to be ordered separately)	CX 03 MP	

Materials

Insert	polycarbonate (PC)
UL 94 flame rating	V-0
Colour	blue, RAL 5015

- Identical male and female modular units; female contacts with or without closing valve;
- pneumatic contacts for pressure values up to 10 bar, for use with clean and dry compressed air;
- use of tubes with Ø 3 - 4 and 6 mm, and replacement of tubes with assembled units;
- possibility of using tubes with different diameters in the same modular unit;
- coding and guiding pins must be used for pneumatic contacts modules (**CRM CX / CRF CX**);
- these pins also provide coding if pneumatic contacts modules are used exclusively;
- the use of pneumatic contacts requires an appropriate filtering and dehydration system to prevent dangerous condensation.

Accessories

	Pages
MIXO Frames	
Metal frames for HNM modular units	H.62
Thermoplastic docking frames	H.65-68

CX..MPA/MPQ/MP HNM (High Number of Mating cycles)

Metal pneumatic contacts

size **1 module**

Insulation resistance	≥ 10 GΩ
Ambient temperature limit	-40 °C ... +80 °C
Mechanical life (cycles)	≥ 10 000

Item	Description	Part No.	Dimension
	Quick-fitting (outer Ø) male contacts, without shut-off valve, for tube Ø 3 mm	angled CX 3.0 MPAM	 CX .. MPAM A (mm) B (mm) 3.0 43,5 15,5 4.0 45,1 18,7 6.0 47,5 20,5
	without shut-off valve, for tube Ø 4 mm	CX 4.0 MPAM	
	without shut-off valve, for tube Ø 6 mm	CX 6.0 MPAM	
	Quick-fitting (outer Ø) female contacts, without shut-off valve, for tube Ø 3 mm	angled CX 3.0 MPAF	 CX .. MPAF A (mm) B (mm) 3.0 42,4 15,5 4.0 44,0 18,7 6.0 46,4 20,5
	without shut-off valve, for tube Ø 4 mm	CX 4.0 MPAF	
	without shut-off valve, for tube Ø 6 mm	CX 6.0 MPAF	
	Quick-fitting (outer Ø) female contacts, with shut-off valve, for tube Ø 3 mm	angled CX 3.0 MPAV	 CX .. MPAV A (mm) B (mm) 3.0 49,9 15,5 4.0 51,5 18,7 6.0 53,9 20,5
	with shut-off valve, for tube Ø 4 mm	CX 4.0 MPAV	
	with shut-off valve, for tube Ø 6 mm	CX 6.0 MPAV	
	Quick-fitting (outer Ø) male contacts, without shut-off valve, for tube Ø 3 mm	straight CX 3.0 MPQM	 CX .. MPQM A (mm) 3.0 41,2 4.0 45,5 6.0 47,5
	without shut-off valve, for tube Ø 4 mm	CX 4.0 MPQM	
	without shut-off valve, for tube Ø 6 mm	CX 6.0 MPQM	
	Quick-fitting (outer Ø) female contacts, without shut-off valve, for tube Ø 3 mm	straight CX 3.0 MPQF	 CX .. MPQF A (mm) 3.0 40,1 4.0 44,4 6.0 46,4
	without shut-off valve, for tube Ø 4 mm	CX 4.0 MPQF	
	without shut-off valve, for tube Ø 6 mm	CX 6.0 MPQF	
	Quick-fitting (outer Ø) female contacts, with shut-off valve, for tube Ø 3 mm	straight CX 3.0 MPQV	 CX .. MPQV A (mm) 3.0 47,6 4.0 51,9 6.0 53,9
	with shut-off valve, for tube Ø 4 mm	CX 4.0 MPQV	
	with shut-off valve, for tube Ø 6 mm	CX 6.0 MPQV	
	Hose barbs (inner Ø) male contacts, without shut-off valve, for tube Ø 3 mm	straight CX 3.0 MPM	 CX .. MPM A (mm) B (mm) 3.0 37,6 7,9 4.0 41,3 11,6 6.0 40,2 10,4
	without shut-off valve, for tube Ø 4 mm	CX 4.0 MPM	
	without shut-off valve, for tube Ø 6 mm	CX 6.0 MPM	
	Hose barbs (inner Ø) female contacts, without shut-off valve, for tube Ø 3 mm	straight CX 3.0 MPF	 CX .. MPF A (mm) B (mm) 3.0 36,5 7,9 4.0 40,2 11,6 6.0 39,1 10,4
	without shut-off valve, for tube Ø 4 mm	CX 4.0 MPF	
	without shut-off valve, for tube Ø 6 mm	CX 6.0 MPF	
	Hose barbs (inner Ø) female contacts, with shut-off valve, for tube Ø 3 mm	straight CX 3.0 MPV	 CX .. MPV A (mm) B (mm) 3.0 39,5 7,9 4.0 43,2 11,6 6.0 42,1 10,4
	with shut-off valve, for tube Ø 4 mm	CX 4.0 MPV	
	with shut-off valve, for tube Ø 6 mm	CX 6.0 MPV	

Materials	
Contact	nickel plated brass

CX 02 MPB HNM (High Number of Mating cycles)

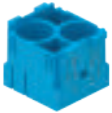
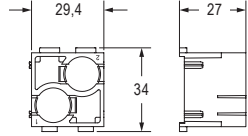

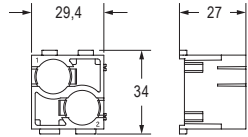
 size **2 modules**

Inserts for metal pneumatic contacts

Insulation resistance	≥ 10 GΩ
Ambient temperature limit	-40 °C ... +80 °C
Mechanical life (cycles)	≥ 10 000

(pending: DNV and BV)

(pending: cURus)

Item	Description	Part No.	Dimension
	Male inserts with 2 housings for tube Ø 8 - 10 mm Without contacts (to be ordered separately)	CX 02 MPBM	
	Female inserts with 2 housings for tube Ø 8 - 10 mm Without contacts (to be ordered separately)	CX 02 MPBF	

Materials

Insert	polycarbonate (PC)
UL 94 flame rating	V-0
Colour	blue, RAL 5015

- Identical male and female modular units;
- pneumatic contacts for pressure values up to 10 bar, for use with clean and dry compressed air;
- use of tubes with Ø 8 and 10 mm, and replacement of tubes with assembled units;
- possibility of using tubes with different diameters in the same modular unit;
- female contacts with or without closing valve;
- working temperature range:
40 °C ÷ + 80 °C;
- coding and guiding pins must be used for pneumatic contacts modules (**CRM CX / CRF CX**);
- these pins also provide coding if pneumatic contacts modules are used exclusively;
- the use of pneumatic contacts requires an appropriate filtering and dehydration system to prevent dangerous condensation.

Accessories

	Pages
MIXO Frames	
Metal frames for HNM modular units	H.62
Thermoplastic docking frames	H.65-68

Can be used in bulkhead mounting housings or in high construction housings or in high construction hoods.

CX..MPQ / MP HNM (High Number of Mating cycles)

size 2 modules

Metal pneumatic contacts

Insulation resistance	≥ 10 GΩ
Ambient temperature limit	-40 °C ... +80 °C
Mechanical life (cycles)	≥ 10 000

Item	Description	Part No.	Dimension
	Quick-fitting (outer Ø) male contacts, without shut-off valve, for tube Ø 8 mm without shut-off valve, for tube Ø 10 mm	straight CX 8.0 MPQM CX 10 MPQM	
	Quick-fitting (outer Ø) female contacts, without shut-off valve, for tube Ø 8 mm without shut-off valve, for tube Ø 10 mm	straight CX 8.0 MPQF CX 10 MPQF	
	Quick-fitting (outer Ø) female contacts, with shut-off valve, for tube Ø 8 mm with shut-off valve, for tube Ø 10 mm	straight CX 8.0 MPQV CX 10 MPQV	
	Hose barbs (inner Ø) male contacts, without shut-off valve, for tube Ø 8 mm without shut-off valve, for tube Ø 10 mm	straight CX 8.0 MPM CX 10 MPM	
	Hose barbs (inner Ø) female contacts, without shut-off valve, for tube Ø 8 mm without shut-off valve, for tube Ø 10 mm	straight CX 8.0 MPF CX 10 MPF	
	Hose barbs (inner Ø) female contacts, with shut-off valve, for tube Ø 8 mm with shut-off valve, for tube Ø 10 mm	straight CX 8.0 MPV CX 10 MPV	

Materials

Contact	nickel plated brass
---------	---------------------

RX..T HNM (High Number of Mating cycles)

Frames for modular units

2-slot sized – 6-slot sized

Mechanical life (cycles)

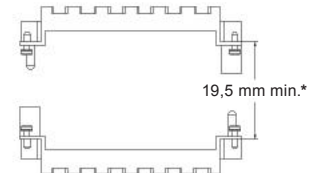
- with HNM frames and standard enclosures, single lever	≥ 5 000
- with HNM frames and HNM enclosures	≥ 10 000

ECBT2.E115072 | ECBT8.E115072

Item	Description	Part No.	Dimension															
	Frames for modular units for 2 modular units, size 44.27 for 3 modular units, size 57.27 for 4 modular units, size 77.27 for 6 modular units, size 104.27 Supplied with lock-in tab Assignment of attribute "for hoods" is merely conventional: this type can be mounted either in a hood or in a housing. In a modular connector coupling there shall be always a male frame and female type	Type for hoods RX 02 TM RX 03 TM RX 04 TM RX 06 TM	 <table border="1"> <thead> <tr> <th>Part No.</th> <th>A (mm)</th> <th>for hoods size</th> </tr> </thead> <tbody> <tr> <td>RX 02 TM</td> <td>44</td> <td>44.27</td> </tr> <tr> <td>RX 03 TM</td> <td>57</td> <td>57.27</td> </tr> <tr> <td>RX 04 TM</td> <td>77,5</td> <td>77.27</td> </tr> <tr> <td>RX 06 TM</td> <td>104</td> <td>104.27</td> </tr> </tbody> </table>	Part No.	A (mm)	for hoods size	RX 02 TM	44	44.27	RX 03 TM	57	57.27	RX 04 TM	77,5	77.27	RX 06 TM	104	104.27
	Part No.	A (mm)	for hoods size															
RX 02 TM	44	44.27																
RX 03 TM	57	57.27																
RX 04 TM	77,5	77.27																
RX 06 TM	104	104.27																
	Frames for modular units, for housings for 2 modular units, size 44.27 for 3 modular units, size 57.27 for 4 modular units, size 77.27 for 6 modular units, size 104.27 Supplied with lock-in tab Assignment of attribute "for housings" is merely conventional: this type can be mounted either in a hood or in a housing. In a modular connector coupling there shall be always a male frame and female type	Type for housings RX 02 TF RX 03 TF RX 04 TF RX 06 TF	 <table border="1"> <thead> <tr> <th>Part No.</th> <th>A (mm)</th> <th>for housings size</th> </tr> </thead> <tbody> <tr> <td>RX 02 TF</td> <td>44</td> <td>44.27</td> </tr> <tr> <td>RX 03 TF</td> <td>57</td> <td>57.27</td> </tr> <tr> <td>RX 04 TF</td> <td>77,5</td> <td>77.27</td> </tr> <tr> <td>RX 06 TF</td> <td>104</td> <td>104.27</td> </tr> </tbody> </table>	Part No.	A (mm)	for housings size	RX 02 TF	44	44.27	RX 03 TF	57	57.27	RX 04 TF	77,5	77.27	RX 06 TF	104	104.27
	Part No.	A (mm)	for housings size															
RX 02 TF	44	44.27																
RX 03 TF	57	57.27																
RX 04 TF	77,5	77.27																
RX 06 TF	104	104.27																

Polarisation of frames with relative identification letters and couplings

frames	size 44.27	size 57.27	size 77.27	size 104.27
for hoods				
for housings				



*Distance for:
 - electric and fibre optic contacts: 20,5 mm max.;
 - pneumatic contacts 20,5 mm max.

The module support frames are marked:
 - hoods: **A-B** (44.27), **A-C** (57.27), **A-D** (77.27) and **A-F** (104.27)
 - housings: **a-b** (44.27), **a-c** (57.27), **a-d** (77.27) and **a-f** (104.27)

Positioning the modules in the frames according to the respective letters is ensuring the specular assembly of modules, for which the hood will be coupled correctly to the housing.

Enclosures sizes 44.27, 57.27, 77.27 and 104.27	Pages
Specialized Applications	
HNM High Number of Mating cycles	1.74-81

C-TYPE and V-TYPE 2-levers version cannot be used to reach 5 000 matings


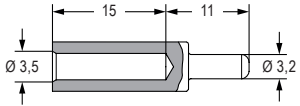

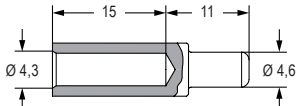

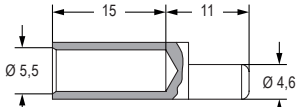

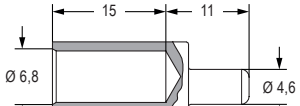

Earth terminal
 - large: for cables from 4-6 mm², AWG 12-10
 - small: for cables from 1-2,5 mm², AWG 18-14

In order to accommodate larger PE conductor cross-sectional area, use **CGT PE** adapters, see page **H.63**

It is recommended the use of **CRF CX / CRM CX** coding pins.

CGT

PE terminal adapters for MIXO frames

Item	Description	Part No.	Dimension
	PE wire terminal adapter 6 mm ² (10 AWG) Cannot be used with T-TYPE surface mounting housings and horizontal cable outlet hoods.	CGT 6.0	
	PE wire terminal adapter 10 mm ² (8 AWG) Cannot be used with T-TYPE surface mounting housings and horizontal cable outlet hoods.	CGT 10	
	PE wire terminal adapter 16 mm ² (6 AWG) Cannot be used with T-TYPE surface mounting housings and horizontal cable outlet hoods.	CGT 16	
	PE wire terminal adapter 25 mm ² (4 AWG) Cannot be used with T-TYPE surface mounting housings and horizontal cable outlet hoods.	CGT 25	
	Headless screw M4×6, stainless steel, kit of 10 pcs. For the use with T-TYPE bulkhead housings and vertical entry hoods it is needed to replace the M4 screw of the 6 mm ² PE contact of the frame with the headless screw CR VGM4	CR VGM4	

Materials

PE terminals	nickel-plated brass
--------------	---------------------

How to use the PE adapters:

- Strip 15 mm of flexible PE protective cable.
- Crimp the cable on the CGT adapter by using the CPPZ C pliers with the CGD 10 C dies for 6 mm² and 10 mm², CGD 16 C dies for 16 mm² and CGD 25 C dies for 25 mm².
- Fix the adapter tip in the larger earth terminal (6 mm²) for CGT 10, CGT 16, CGT 25 or in the smaller earth terminal (2,5 mm²) for CGT 6.0 of frames RX...TM/TF.


Accessories	Pages
MIXO Frames	
Metal frames for HNM modular units	H.62

Can be used in bulkhead mounting housings or in high construction hoods.

CR..DF HNM (High Number of Mating cycles)

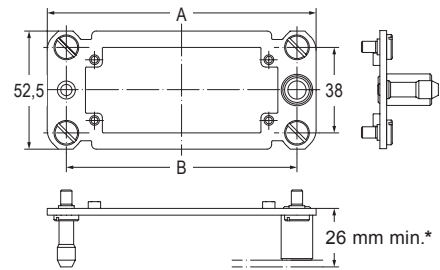
Stainless-steel self-centring floating frames

Mechanical life (cycles)	
- with HNM frames and HNM enclosures	≥ 10 000
Compensation range	
- x axis	± 1,5 mm
- y axis	± 1,5 mm

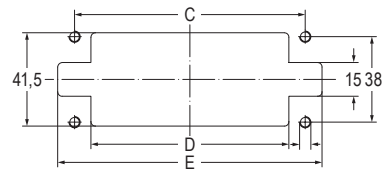
Item	Description
	<p>Stainless steel frame, to be mounted on: inserts size 44.27 and MIXO frames, 2 inserts inserts size 57.27 and MIXO frames, 3 inserts inserts size 77.27 and MIXO frames, 4 inserts inserts size 104.27 and MIXO frames, 6 inserts</p> <p>Cannot be used with CT, CTS and CTSE inserts</p> <p>Supplied with 4 M5 shoulder screws with cylindrical head and notch to fix the frame in place</p> <p>As the frames are floating, the PE earthing connection of the metal surfaces on which they are mounted (mounting bases) must be performed separately and cannot be done by connecting the PE earthing contact to the corresponding connector inserts.</p>

Part No.

[CR 06 DF](#)
[CR 10 DF](#)
[CR 16 DF](#)
[CR 24 DF](#)

Dimension


*Distance for:
 - electric and fibre optic contacts: 26,5 mm max.;
 - pneumatic contacts: 26,5 mm max.

panel cut-out


Part No.	A (mm)	B (mm)	C (mm)	D (mm)	E (mm)
CR 06 DF	86	69	69	54,5	84
CR 10 DF	99	82	82	67,5	97
CR 16 DF	119,5	102,5	102,5	88	117,5
CR 24 DF	146	129	129	114,5	144

Materials	
Floating frame	stainless steel
Fixing screws	zinc-plated steel

Designed to be used in the transportation, printing and power electronic industries (for example boxes for rack cabinets) and in all industrial applications that require, during assembly or maintenance, the connection of connectors without possibility of controlling the alignment.

Enables the self-centring coupling of two corresponding connectors without the use of enclosures; they freely move on their base plate ($\pm 1,5$ mm on both axes) ensuring the alignment of the coupling.

CX 02 PD HNM (High Number of Mating cycles)

Thermoplastic docking frames

2-slot sized

EN 60529 rating	IP2X (IPXXB)
UL 50 / UL 50E	
Ambient temperature limit	-40 °C ... +125 °C
Mechanical life when fitted with MIXO modules (cycles)	≥ 10 000

(pending: CQC, DNV and BV)

(pending: cURus)

Item	Description	Part No.	Dimension
------	-------------	----------	-----------

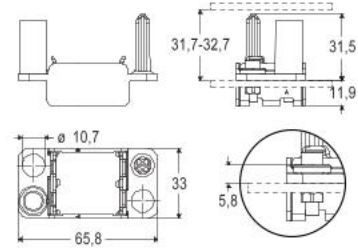


Float-mount thermoplastic insulating docking frame for 2 modular units

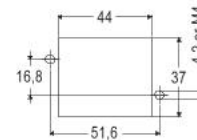
* supplied with 2x floating washers to enable the frame to be float-mounted using standard M4 fixing screws (not supplied)

The leading centring system compensates for tolerances of ± 2 mm both in x and y axes.

[CX 02 PDM](#)

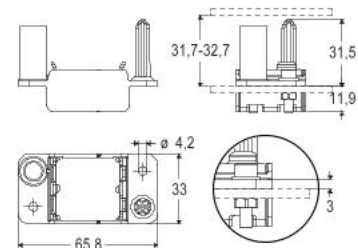


Panel cut-out

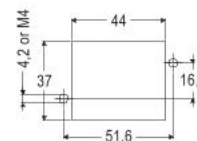


Fixed-mount thermoplastic insulating docking frame for 2 modular units

[CX 02 PDF](#)



Panel cut-out



Materials	
Frame	polycarbonate (PC)
UL 94 flame rating	V-0
Colour	pebble grey, RAL 7032

CX 03 PD HNM (High Number of Mating cycles)

Thermoplastic docking frames

3-slot sized

EN 60529 rating	IP2X (IPXXB)
UL 50 / UL 50E	
Ambient temperature limit	-40 °C ... +125 °C
Mechanical life when fitted with MIXO modules (cycles)	≥ 10 000

(pending: CQC, DNV and BV)

(pending: cURus)

Item	Description	Part No.	Dimension
------	-------------	----------	-----------

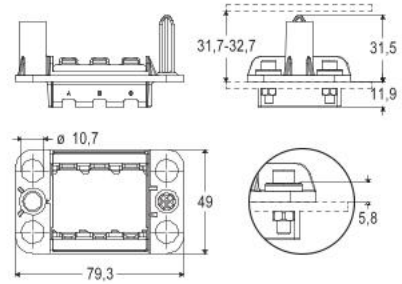


Float-mount thermoplastic insulating docking frame for 3 modular units

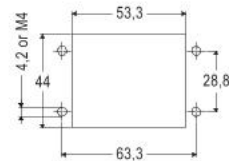
[CX 03 PDM](#)

* supplied with 4× floating washers to enable the frame to be float-mounted using standard M4 fixing screws (not supplied)

The leading centring system compensates for tolerances of ± 2 mm both in x and y axes.

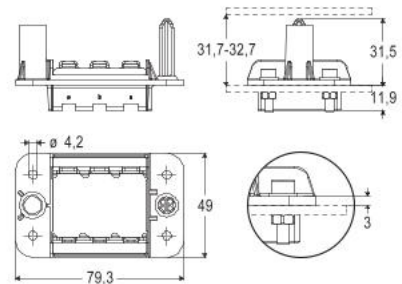


Panel cut-out

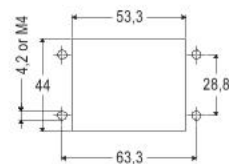


Fixed-mount thermoplastic insulating docking frame for 3 modular units

[CX 03 PDF](#)



Panel cut-out



Materials

Frame	polycarbonate (PC)
UL 94 flame rating	V-0
Colour	pebble grey, RAL 7032

CX 04 PD HNM (High Number of Mating cycles)

Thermoplastic docking frames

4-slot sized

EN 60529 rating	IP2X (IPXXB)
UL 50 / UL 50E	
Ambient temperature limit	-40 °C ... +125 °C
Mechanical life when fitted with MIXO modules (cycles)	≥ 10 000

(pending: CQC, DNV and BV)

(pending: cURus)

Item	Description	Part No.	Dimension
------	-------------	----------	-----------

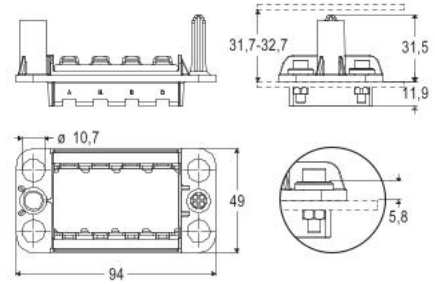


Float-mount thermoplastic insulating docking frame for 4 modular units

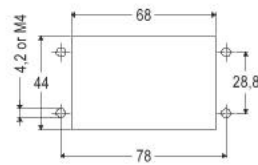
[CX 04 PDM](#)

* supplied with 4x floating washers to enable the frame to be float-mounted using standard M4 fixing screws (not supplied)

The leading centring system compensates for tolerances of ± 2 mm both in x and y axes.

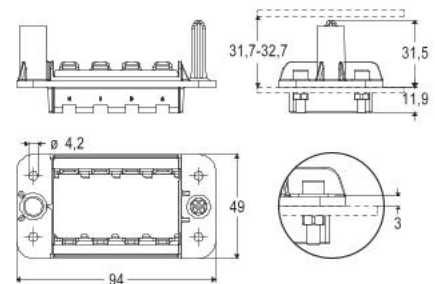


Panel cut-out

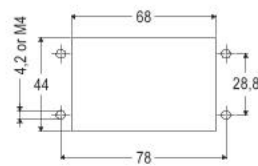


Fixed-mount thermoplastic insulating docking frame for 4 modular units

[CX 04 PDF](#)



Panel cut-out



Materials

Frame	polycarbonate (PC)
UL 94 flame rating	V-0
Colour	pebble grey, RAL 7032

CX 06 PD HNM (High Number of Mating cycles)

Thermoplastic docking frames

6-slot sized

EN 60529 rating	IP2X (IPXXB)
UL 50 / UL 50E	
Ambient temperature limit	-40 °C ... +125 °C
Mechanical life when fitted with MIXO modules (cycles)	≥ 10 000

(pending: CQC, DNV and BV)

(pending: cURus)

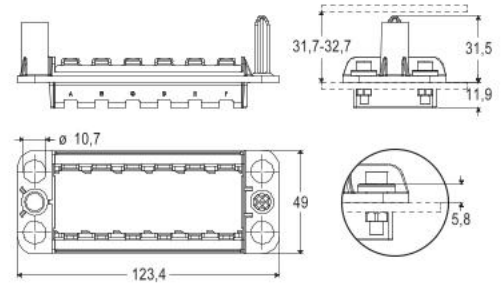
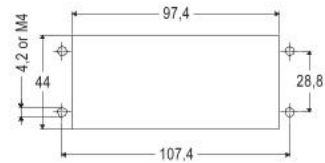
Item	Description	Part No.	Dimension
------	-------------	----------	-----------



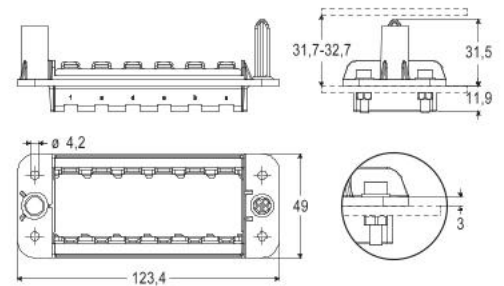
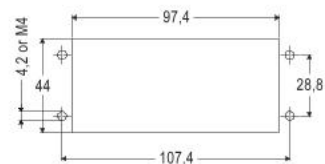
Float-mount thermoplastic insulating docking frame for 6 modular units

* supplied with 4× floating washers to enable the frame to be float-mounted using standard M4 fixing screws (not supplied)

The leading centring system compensates for tolerances of ± 2 mm both in x and y axes.

[CX 06 PDM](#)

Panel cut-out


Fixed-mount thermoplastic insulating docking frame for 6 modular units

[CX 06 PDF](#)

Panel cut-out


Materials	
Frame	polycarbonate (PC)
UL 94 flame rating	V-0
Colour	pebble grey, RAL 7032




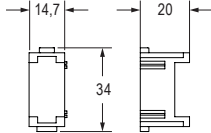
CX FM

Dummy module

size **1 module**



CALUS ECBT2.E115072 | ECBT8.E115072

Item	Description	Part No.	Dimension
	<p>Dummy module for unused frame seats</p> <p>This version is formed by a single piece and has a reduced weight.</p> <p>It allows the mating of a MIXO insert including it with a corresponding MIXO insert even having, in front of the dummy module, a regular male or female module equipped with contacts, which obviously will not work.</p> <p>The sole exceptions to this feature are that an insert with this dummy module cannot mate an inserts showing in front a CX 3/4 XDF/M, CX 04 XF/M or CX 02 HF modules.</p>	<p>CX FM</p>	

Materials

Insert	polycarbonate (PC)
UL 94 flame rating	V-0
Colour	pebble grey, RAL 7032

Accessories

	Pages
MIXO Frames	
Metal frames for HNM modular units	H.62
Thermoplastic docking frames	H.65-68

Individual modules with a width of 14,7 mm can be installed in plastic supports.



HNM

enclosures



The HNM series of connector enclosures has been developed to be combined with the HNM series multipole connector inserts to provide the same reliable protection as the standard series but for a consistently extended, high number of matings. When the number of 500 mating cycles guaranteed life of standard connector hoods and housings is insufficient to provide a reasonably long-life span in those

connector applications that by function are foreseen to be subject to very frequent connections and disconnections, it is necessary to opt for a solution able to increase that guaranteed lifetime. The HNM series of connector enclosures achieves this goal, extending the guaranteed number of matings up to 10 000 (5 000 for the 21.21 size).

TECHNICAL FEATURES

- > Compact housings size 21.21 (bulkhead-mounting or surface mounting) are equipped with CLASS single-locking levers made of stainless steel with special anti-friction treatment.
- > The CLASS locking lever has been chosen and treated to reduce wear due to friction at a minimum. Even mated on standard hoods, it can reduce wear on the corresponding locking pegs, producing virtually no friction by applying extraordinary lubrication on the hinged rolls. The counterpart hoods are, therefore, standard metallic types with fused pegs.
- > Standard housings size 44.27, 57.27, 77.27 and 104.27 (bulkhead-mount or surface mount) equipped with V-TYPE single locking lever with special anti-friction treatment have to be mated to hoods with riveted anti-friction pegs that facilitate frequent opening and closing.
- > The locking means, comprising both the locking lever and locking pegs, are chosen and treated to reduce wear due to friction at a minimum, thanks to the use of the clever proprietary design of the V-TYPE locking lever, which is already in standard enclosures can provide significantly reduced wear on the corresponding locking pegs, producing minimal friction, furtherly reduced by the application of a special anti-friction lubrication treatment.



- > Riveted anti-friction rolling pegs already provide the counterpart hoods for locking on the long side and are further improved by the special anti-friction lubrication treatment.
- > **The HNM size 21.21 series of connector enclosures achieves this goal, extending the guaranteed number of matings up to 5 000.**



Riveted **anti-friction** pegs

V-TYPE single locking lever with special **anti-friction** treatment

Stainless steel lever with special **anti-friction** treatment on the hinged rolls



HNM series – High Number of Mating cycles

 size **21.21**


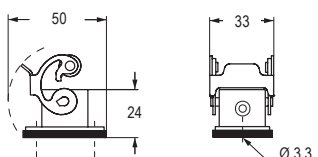

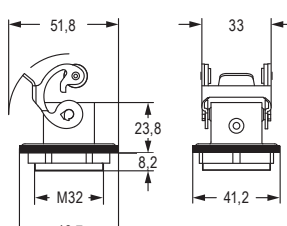

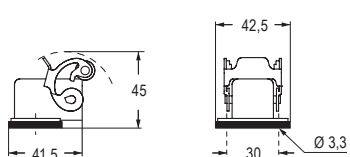

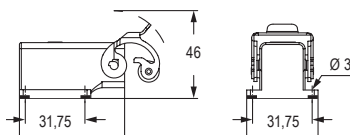

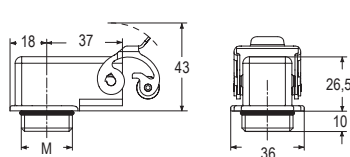
Housings – 1 lever

Specialized Applications



EN 60529	IP44
With CKR 65 (D)	IP66 / IP67 / IP69
UL 50 / UL 50E	Type 12
With CKR 65 (D)	Type 4 / 4X
Ambient temperature limits	-40 °C ... +125 °C
Mechanical life (cycles)	≥ 5 000


 C[®] AUS ECBT2.E115072 | ECBT8.E115072

Item	Description	Part No.	Entry	Dimension
	Bulkhead mounting housings, 1 stainless steel lever	RKAX 03 I		
	Bulkhead mounting housings, 1 stainless steel lever, M32 fixing thread, with O-ring gasket or with flange gasket - Locknut supplied on request, see Cable glands catalogue (article AS M32N metallic).	With O-ring gasket RKAX IF With flange gasket and locknut RKAX IFC	M32 M32	
	Angled bulkhead mounting housings, 1 stainless steel lever Not suitable for CQ4 series inserts	RKAX 03 IA		
	Angled bulkhead mounting housings, 1 stainless steel lever, fixing by 4 screws	RKAX 03 IA4		
	Angled bulkhead mounting housings, 1 stainless steel lever, M20 or M25 fixing thread, with O-ring gasket	RKAX IAF20 RKAX IAF25	M20 M25	

Compact 21.21 Inserts	Poles	Pages
CQ4	40 A	H.6
RQ	16 A	H.7
CQ	6,5 A	H.8
CD	10 A	H.9

Note: to obtain the IP66 / IP67 / IP69 degree of protection it is necessary to replace the fixing screw supplied with all inserts, with the one with gasket included in the CKR 65 kit, to be purchased separately, except for the inserts listed below (already supplied with a fixing screw with gasket):

- CQF/M 07, CQF/M 12
- CJ KF
- CJK 8FT /8IFT
- CUK 2FT /3FT
- CX 1/2 BDF/M
- CLK 04 SCF /SCF-H /SCM

Complete with:



Hoods
21.21 enclosures
Pages A.64

Accessories:



CKR 65
gasket and screw kits
for IP66 / IP67 / IP69, page A.67



HNM series – High Number of Mating cycles

size **21.21**

Housings and hoods – 1 lever

Specialized Applications

EN 60529	IP44
With CKR 65 (D)	IP66 / IP67 / IP69
UL 50 / UL 50E	Type 12
With CKR 65 (D)	Type 4 / 4X
Ambient temperature limits	-40 °C ... +125 °C
Mechanical life (cycles)	≥ 5 000



ECBT2.E115072 | ECBT8.E115072

Item	Description	Part No.	Entry	Dimension														
	Angled bulkhead mounting housings, 1 stainless steel lever, with cable entry, open or closed bottom flange Not suitable for CQ4 series inserts	Open bottom flange RKAX IAP20	M20															
		Closed bottom flange RKAX AP20	M20			Angled surface mounting housings, 1 stainless steel lever, with cable entry, fixing by 4 screws, open or closed bottom flange	Open bottom RKAX IAP25	M25		Closed bottom RKAX AP25	M25		Hoods, 1 stainless steel lever, top entry Not suitable for CQ4 series inserts	RKAX VG20	M20			Hoods, 1 stainless steel lever, top entry
	Angled surface mounting housings, 1 stainless steel lever, with cable entry, fixing by 4 screws, open or closed bottom flange	Open bottom RKAX IAP25	M25															
		Closed bottom RKAX AP25	M25			Hoods, 1 stainless steel lever, top entry Not suitable for CQ4 series inserts	RKAX VG20	M20			Hoods, 1 stainless steel lever, top entry	RKAX VG25	M25					
	Hoods, 1 stainless steel lever, top entry Not suitable for CQ4 series inserts	RKAX VG20	M20															
	Hoods, 1 stainless steel lever, top entry	RKAX VG25	M25															

Compact 21.21 Inserts	Poles	Pages
CQ4	40 A	3 + ⊕ H.6
RQ	16 A	5 + ⊕ H.7
CQ	6,5 A	21 + ⊕ H.8
CD	10 A	8 H.9

Note: to obtain the IP66 / IP67 / IP69 degree of protection it is necessary to replace the fixing screw supplied with all inserts, with the one with gasket included in the CKR 65 kit, to be purchased separately, except for the inserts listed below (already supplied with a fixing screw with gasket):

- CQF/M 07, CQF/M 12
- CJ KF
- CJK 8FT /8IFT
- CUK 2FT /3FT
- CX 1/2 BDF/M
- CLK 04 SCF /SCF-H /SCM

Complete with:



Hoods
21.21 enclosures
Pages A.64

Accessories:



CKR 65
gasket and screw kits
for IP66 / IP67 / IP69, page A.67



HNM series – High Number of Mating cycles

size **44.27**

Housings – 1 lever – with gasket

Specialized Applications

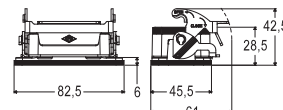


EN 60529	IP65 / IP66 / IP69
UL 50 / UL 50E	Type 12 / 4 / 4X
Ambient temperature limits	-40 °C ... +125 °C
Mechanical life (cycles)	≥ 10 000

CALUS ECBT2.E115072 | ECBT8.E115072

Item	Description	Part No.	Entry	Dimension
------	-------------	----------	-------	-----------

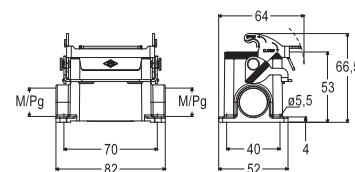
Bulkhead mounting housings,
1 lever and gasket [RVI 06 L](#)



Surface mounting housings,
1 lever and gasket [RVP 06 L20](#)
[RVP 06 L220](#)



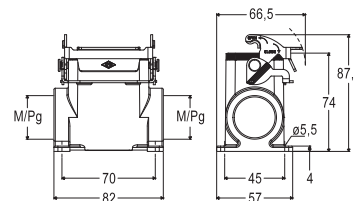
M20
M20 x 2



Surface mounting housings,
1 lever and gasket,
high construction [RVAP 06 L32](#)
[RVAP 06 L232](#)



M32
M32 x 2



STANDARD 44.27

H

Inserts size 44.27	Poles	Pages	MIXO Modular Inserts	Pages
RCE 16 A	6 + ⊕	H.10	MIXO HNM modules	H.38-60
RSH 16 A	6 + ⊕	H.14	RX 02 T (2-slot sized MIXO HNM frames)	H.62
RDD 10 A	24 + ⊕	H.22		
RDSH 10 A	9 + ⊕	H.26		

Accessories:



CR 06 DF
Self-centring floating
frame HNM
Page H.64



HNM series – High Number of Mating cycles

size **44.27**

Hoods – 2 anti-friction pegs – without gasket

Specialized Applications

CE UK



EN 60529	IP65 / IP66 / IP69
UL 50 / UL 50E	Type 12 / 4 / 4X
Ambient temperature limits	-40 °C ... +125 °C
Mechanical life (cycles)	≥ 10 000

ECBT2.E115072 | ECBT8.E115072

Item	Description	Side entry	Top entry	Entry	Dimension
	Hoods, 2 pegs, without gasket, side entry	RHO 06 L25		M25	
	Hoods, 2 pegs, without gasket, top entry		RHV 06 L25	M25	
	Hoods, 2 pegs, without gasket, side or top entry, high construction	RFO 06 L32	RFV 06 L32	M32	
	Hoods, 2 pegs, without gasket, high construction, designed to be drilled	Without entry		RAC 06 L	

STANDARD 44.27

H

Inserts size 44.27	Poles	Pages	MIXO Modular Inserts	Pages
RCE 16 A	6 + ⊕	H.10	MIXO HNM modules	H.38-60
RSH 16 A	6 + ⊕	H.14	RX 02 T (2-slot sized MIXO HNM frames)	H.62
RDD 10 A	24 + ⊕	H.22		
RDSH 10 A	9 + ⊕	H.26		

Accessories:



CR 06 DF
Self-centring floating frame HNM
Page H.64



HNM series – High Number of Mating cycles

size **57.27**

Housings – 1 lever – with gasket

Specialized Applications



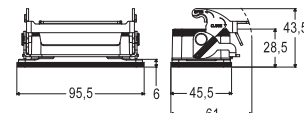
EN 60529	IP65 / IP66 / IP69
UL 50 / UL 50E	Type 12 / 4 / 4X
Ambient temperature limits	-40 °C ... +125 °C
Mechanical life (cycles)	≥ 10 000

CALUS ECBT2.E115072 | ECBT8.E115072

Item	Description	Part No.	Entry	Dimension
------	-------------	----------	-------	-----------

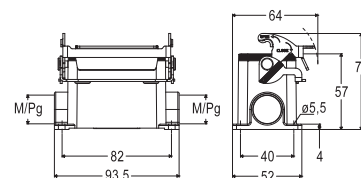


Bulkhead mounting housings,
1 lever and gasket [RVI 10 L](#)



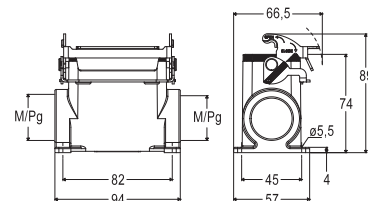
Surface mounting housings,
1 lever and gasket [RVP 10 L20](#)
[RVP 10 L220](#)

M20
M20 x 2



Surface mounting housings,
1 lever and gasket,
high construction [RVAP 10 L32](#)
[RVAP 10 L232](#)

M32
M32 x 2



STANDARD 57.27

H

Inserts size 57.27	Poles	Pages	MIXO Modular Inserts	Pages
RCE 16 A	10 + ⊕	H.11	MIXO HNM modules	H.38-60
RSH 16 A	10 + ⊕	H.15	RX 03 T (3-slot sized MIXO HNM frames)	H.62
RDD 10 A	42 + ⊕	H.23		
RDSH 10 A	18 + ⊕	H.27		

Accessories:



CR 10 DF
Self-centring floating
frame HNM
Page H.64



HNM series – High Number of Mating cycles

size **57.27**

Hoods – 2 anti-friction pegs – without gasket

Specialized Applications


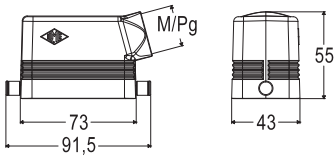

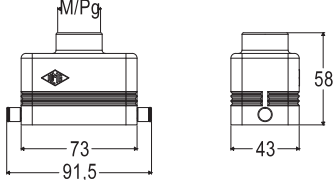

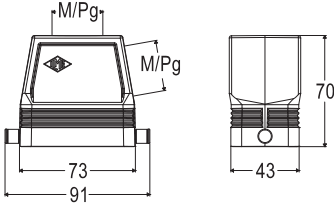

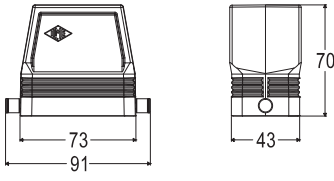


CE UK



EN 60529	IP65 / IP66 / IP69
UL 50 / UL 50E	Type 12 / 4 / 4X
Ambient temperature limits	-40 °C ... +125 °C
Mechanical life (cycles)	≥ 10 000

ALUS ECBT2.E115072 | ECBT8.E115072

Item	Description	Side entry	Top entry	Entry	Dimension
	Hoods, 2 pegs, without gasket, side entry	RHO 10 L25		M25	
	Hoods, 2 pegs, without gasket, top entry		RHV 10 L25	M25	
	Hoods, 2 pegs, without gasket, side or top entry, high construction	RFO 10 L32	RFV 10 L32	M32	
	Hoods, 2 pegs, without gasket, high construction, designed to be drilled	Without entry	RAC 10 L		

STANDARD 57.27

H

Inserts size 57.27	Poles	Pages	MIXO Modular Inserts	Pages
RCE 16 A	10 + ⊕	H.11	MIXO HNM modules	H.38-60
RSH 16 A	10 + ⊕	H.15	RX 03 T (3-slot sized MIXO HNM frames)	H.62
RDD 10 A	42 + ⊕	H.23		
RDSH 10 A	18 + ⊕	H.27		

Accessories:



CR 10 DF
Self-centring floating frame HNM
Page H.64



HNM series – High Number of Mating cycles

size **77.27**

Housings – 1 lever – with gasket

Specialized Applications

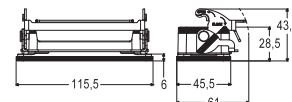


EN 60529	IP65 / IP66 / IP69
UL 50 / UL 50E	Type 12 / 4 / 4X
Ambient temperature limits	-40 °C ... +125 °C
Mechanical life (cycles)	≥ 10 000

CRUS ECBT2.E115072 | ECBT8.E115072

Item	Description	Part No.	Entry	Dimension
------	-------------	----------	-------	-----------

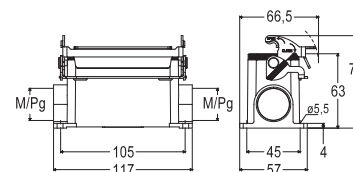
Bulkhead mounting housings,
1 lever and gasket [RVI 16 L](#)



Surface mounting housings,
1 lever and gasket [RVP 16 L25](#)
[RVP 16 L225](#)



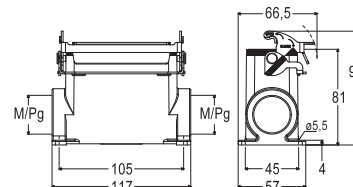
M25
M25 x 2



Surface mounting housings,
1 lever and gasket,
high construction [RVAP 16 L32](#)
[RVAP 16 L232](#)



M32
M32 x 2



STANDARD 77.27

H

Inserts size 77.27	Poles	Pages	MIXO Modular Inserts	Pages
RCE 16 A	16 + ⊕	H.12	MIXO HNM modules	H.38-60
RSH 16 A	16 + ⊕	H.16	RX 04 T (4-slot sized MIXO HNM frames)	H.62
RQEE 16 A	40 + ⊕	H.18		
RD 10 A	40 + ⊕	H.20		
RDD 10 A	72 + ⊕	H.24		
RDSH 10 A	27 + ⊕	H.28		
RXC 80 A / 16 A	4/2 + ⊕	H.30		
RX 40 A / 10 A	12/2 + ⊕	H.32		

Accessories:



CR 16 DF
Self-centring floating
frame HNM
Page H.64



HNM series – High Number of Mating cycles

size **77.27**

Hoods – 2 anti-friction pegs – without gasket

Specialized Applications

CE UK



EN 60529	IP65 / IP66 / IP69
UL 50 / UL 50E	Type 12 / 4 / 4X
Ambient temperature limits	-40 °C ... +125 °C
Mechanical life (cycles)	≥ 10 000

ECBT2.E115072 | ECBT8.E115072

Item	Description	Side entry	Top entry	Entry	Dimension
	Hoods, 2 pegs, without gasket, side entry	RHO 16 L32		M32	
	Hoods, 2 pegs, without gasket, top entry		RHV 16 L32	M32	
	Hoods, 2 pegs, without gasket, side or top entry, high construction	RFO 16 L32	RFV 16 L32	M32	
	Hoods, 2 pegs, without gasket, high construction, designed to be drilled	Without entry			

STANDARD 77.27

H

Inserts size 77.27	Poles	Pages	MIXO Modular Inserts	Pages
RCE 16 A	16 + ⊕	H.12	MIXO HNM modules	H.38-60
RSH 16 A	16 + ⊕	H.16	RX 04 T (4-slot sized MIXO HNM frames)	H.62
RQEE 16 A	40 + ⊕	H.18		
RD 10 A	40 + ⊕	H.20		
RDD 10 A	72 + ⊕	H.24		
RDSH 10 A	27 + ⊕	H.28		
RXC 80 A / 16 A	4/2 + ⊕	H.30		
RX 40 A / 10 A	12/2 + ⊕	H.32		

Accessories:



CR 16 DF
Self-centring floating frame HNM
Page H.64



HNM series – High Number of Mating cycles

size **104.27**

Housings – 1 lever – with gasket

Specialized Applications


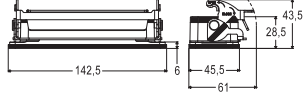

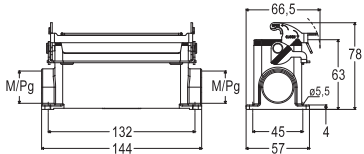

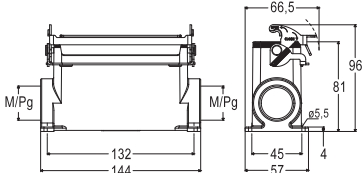


EN 60529	IP65 / IP66 / IP69
UL 50 / UL 50E	Type 12 / 4 / 4X
Ambient temperature limits	-40 °C ... +125 °C
Mechanical life (cycles)	≥ 10 000

CE UK CA



CROSS ECBT2.E115072 | ECBT8.E115072

Item	Description	Part No.	Entry	Dimension
	Bulkhead mounting housings, 1 lever and gasket	RVI 24 L		
	Surface mounting housings, 1 lever and gasket	RVP 24 L25 RVP 24 L225	M25 M25 x 2	
	Surface mounting housings, 1 lever and gasket, high construction	RVAP 24 L32 RVAP 24 L232	M32 M32 x 2	

Inserts size 104.27	Poles	Pages	MIXO Modular Inserts	Pages
RCE 16 A	24 + ⊕	H.13	MIXO HNM modules	H.38-60
RSH 16 A	24 + ⊕	H.17	RX 06 T (6-slot sized MIXO HNM frames)	H.62
RQEE 16 A	64 + ⊕	H.19		
RD 10 A	64 + ⊕	H.21		
RDD 10 A	108 + ⊕	H.25		
RDSH 10 A	42 + ⊕	H.29		
RXC 80 A / 16 A	4/8 + ⊕	H.31		

Accessories:



CR 24 DF
Self-centring floating
frame HNM
Page H.64



HNM series – High Number of Mating cycles

size **104.27**

Hoods – 2 anti-friction pegs – without gasket


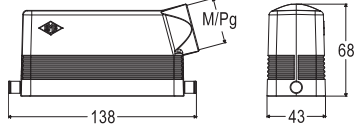

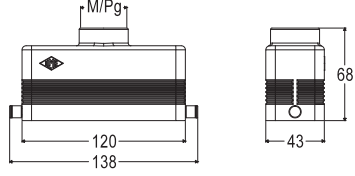

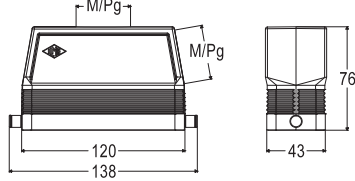

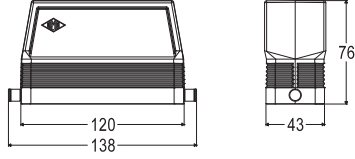
Specialized Applications



EN 60529	IP65 / IP66 / IP69
UL 50 / UL 50E	Type 12 / 4 / 4X
Ambient temperature limits	-40 °C ... +125 °C
Mechanical life (cycles)	≥ 10 000



CE UK
ECBT2.E115072 | ECBT8.E115072

Item	Description	Side entry	Top entry	Entry	Dimension
	Hoods, 2 pegs, without gasket, side entry	RHO 24 L32		M32	
	Hoods, 2 pegs, without gasket, top entry		RHV 24 L32	M32	
	Hoods, 2 pegs, without gasket, side or top entry, high construction	RFO 24 L40	RFV 24 L40	M40	
	Hoods, 2 pegs, without gasket, high construction, designed to be drilled	Without entry	RAC 24 L		

Inserts size 104.27	Poles	Pages	MIXO Modular Inserts	Pages
RCE 16 A	24 + ⊕	H.13	MIXO HNM modules	H.38-60
RSH 16 A	24 + ⊕	H.17	RX 06 T (6-slot sized MIXO HNM frames)	H.62
RQEE 16 A	64 + ⊕	H.19		
RD 10 A	64 + ⊕	H.21		
RDD 10 A	108 + ⊕	H.25		
RDSH 10 A	42 + ⊕	H.29		
RXC 80 A / 16 A	4/8 + ⊕	H.31		

Accessories:



CR 24 DF
Self-centring floating frame HNM
Page H.64

STANDARD 104.27

H

Panel cut-out drawings

For HNM series bulkhead mounting housings

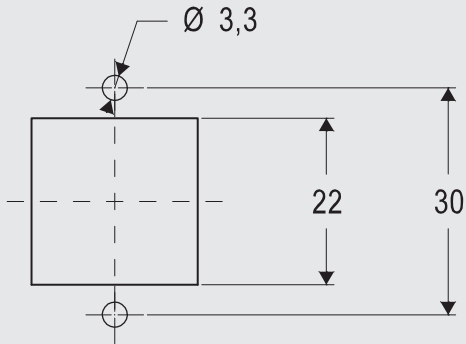
To guarantee the declared IP degree of protection of the housings reported in this catalogue, according to EN IEC 60529 or to the relevant Type rating per ANSI/UL 50 and 50E (for those products bearing approval to those ratings), the surface of the mounting panel must meet the following requirements (definitions are provided in ISO 4287 standard):

Waviness $Wt \leq 0,2$ mm over a distance of 200 mm
(measured on the panel without load)

Roughness $Ra \leq 16$ μm

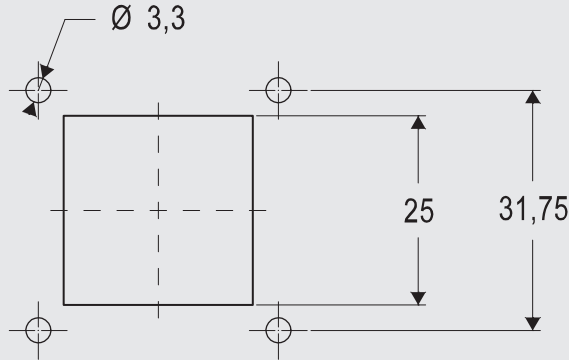
Scale 1:1

Size 21.21 fixing by 2 screws



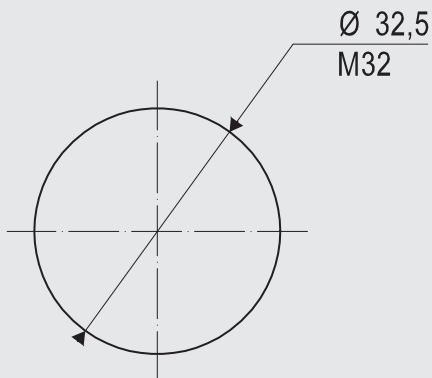
Required screws: 2
Screws size: M3
Recommended torque:
0,8 – 1,0 Nm / 7.1 – 8.9 lb.in

Size 21.21 fixing by 4 screws

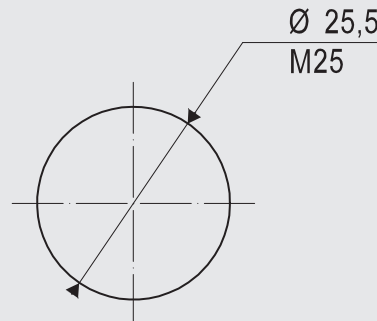


Required screws: 4
Screws size: M3
Recommended torque:
0,8 – 1,0 Nm / 7.1 – 8.9 lb.in

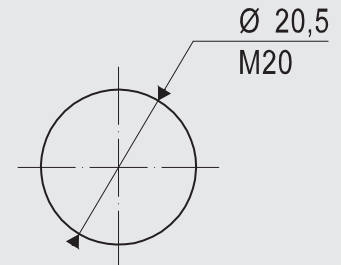
Size 21.21 with M32 fixing thread



Size 21.21 with M25 fixing thread



Size 21.21 with M20 fixing thread



Notes: The values of tightening torque indicated above are just recommended values, that must be related – by the designer of the final application – to the resistance class of the screws (not included), with the assumption that the mounting panel is sufficiently rigid (stiff). If the deflection of the panel, under the effect of tightening the screws, is greater than 0,7 mm over a distance of 100 mm, it is

necessary to use the counter-flanges mentioned in our catalogue or the special flange gaskets available upon request (please contact our Sales Department).

Panel cut-out drawings

For HNM series bulkhead mounting housings

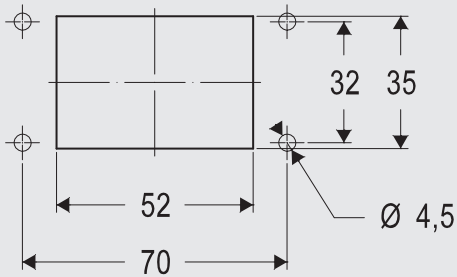
To guarantee the declared IP degree of protection of the housings reported in this catalogue, according to EN IEC 60529 or to the relevant Type rating per ANSI/UL 50 and 50E (for those products bearing approval to those ratings), the surface of the mounting panel must meet the following requirements (definitions are provided in ISO 4287 standard):

Waviness $Wt \leq 0,2$ mm over a distance of 200 mm
(measured on the panel without load)

Roughness $Ra \leq 16$ μm

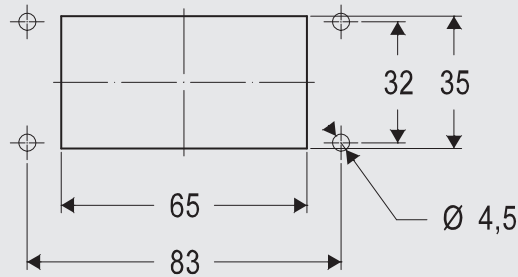
Scale 1:2

Size 44.27



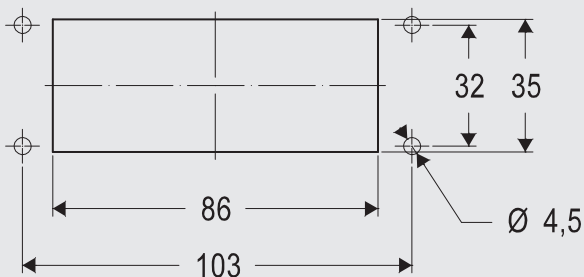
Required screws: 4
Screws size: M4
Recommended torque:
0,8 – 1,2 Nm / 7.1 – 10.6 lb.in

Size 57.27



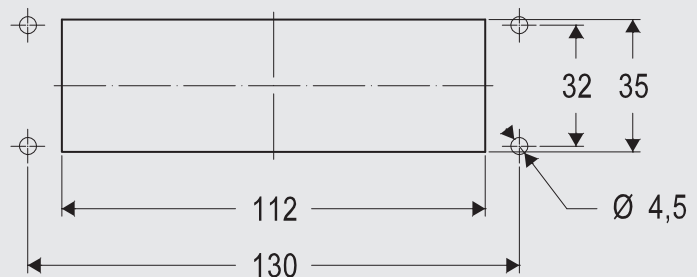
Required screws: 4
Screws size: M4
Recommended torque:
0,8 – 1,2 Nm / 7.1 – 10.6 lb.in

Size 77.27



Required screws: 4
Screws size: M4
Recommended torque:
0,8 – 1,2 Nm / 7.1 – 10.6 lb.in

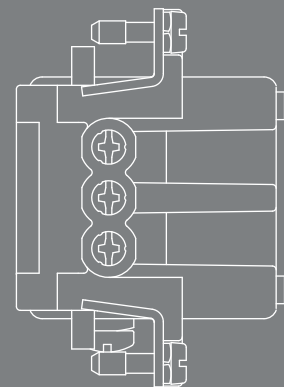
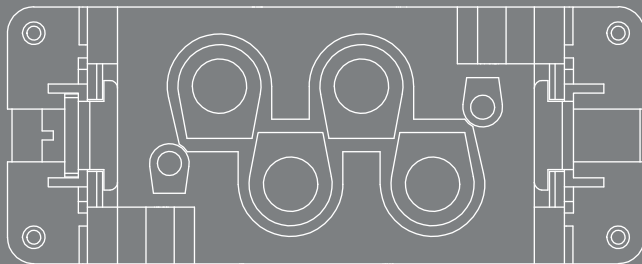
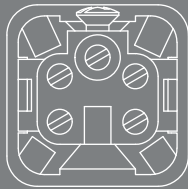
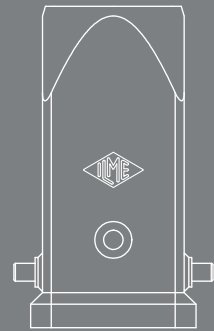
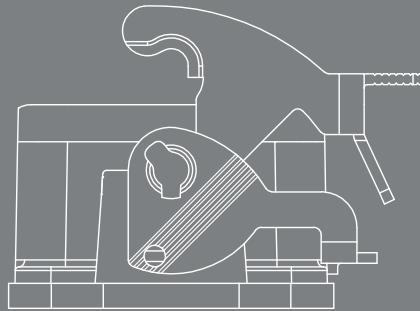
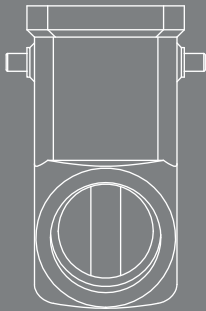
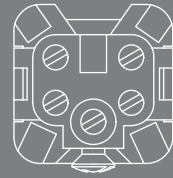
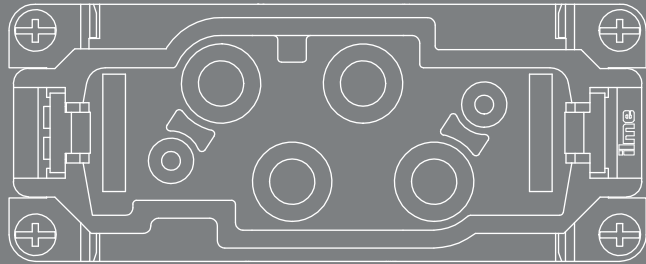
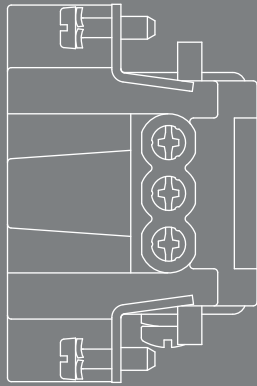
Size 104.27



Required screws: 4
Screws size: M4
Recommended torque:
0,8 – 1,2 Nm / 7.1 – 10.6 lb.in

Notes: The values of tightening torque indicated above are just recommended values, that must be related – by the designer of the final application – to the resistance class of the screws (not included), with the assumption that the mounting panel is sufficiently rigid (stiff). If the deflection of the panel, under the effect of tightening the screws, is greater than 0,7 mm over a distance of 100 mm, it is








necessary to use the counter-flanges mentioned in our catalogue or the special flange gaskets available upon request (please contact our Sales Department).



GENERAL CATALOGUE

180 °C High Temperature connectors series

Contents

Inserts		<i>1.2</i>
21.21 Inserts	Compact size 21.21 CK...RY series - 10 A screw	1.4
		
Standard inserts	Size 44.27, 57.27, 77.27, 104.27 and 104.62 CN...RY series - 16 A screw	1.5-9
		
	CP...RY series - 35 A screw	1.10
Combined inserts	Size 77.27 and 104.27 CX...RY series - 80 A screw	1.11-13
		
Enclosures		<i>1.14</i>
	Compact size 21.21	1.16-17
	Size 44.27, 54.27, 77.27 and 104.27	1.18-25
	Size 77.62 and 104.62	1.26-27

180 °C inserts



Connector inserts developed for use at high ambient temperatures up to 180 °C.

Thanks to a specific thermoplastic insulating material (brown "PPS" polyphenylene sulphide) and in combination with the dedicated connector enclosures "R-Type" for 180 °C, these multipole connectors are particularly suitable for installation on industrial equipment that might be installed in an environment exceeding the standard Upper Limiting Temperature (ULT) of 125 °C for the material.

SUM-UP

- > The 180 °C inserts range for high-temperature applications features screw-type termination technology connectors for 10 A, 16 A, 35 A, and 80 A nominal current carrying capacity.
- > Always refer to the current derating diagrams expressed in each product datasheet to determine the choice of the permanent load applicable to the contacts within the allowed field of operation.
- > Inserts for high-temperature applications are marked with "RY" in the part number.

Product Range

Compact 21.21 size

- > **CK 03 RY / CK 04 RY** inserts with 10 A nominal current

Standard 44.27, 57.27, 77.27, 104.27 and 104.62 size

- > **CNE...RY** inserts with 16 A nominal current
- > **CP 06 RY** inserts with 35 A nominal current

Combined 77.27 and 104.27 size

- > **CX 4/0 RY and CX 4/2 RY** inserts with 80 A nominal current
- > **CX 4/8 RY** inserts with 80 A nominal current

CK 03 RY / CK 04 RY

10 A 230/400 V

size **21.21**

3 poles + ⊕

4 poles + ⊕


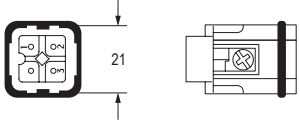

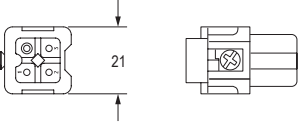

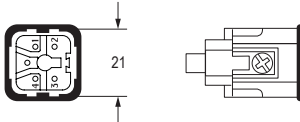

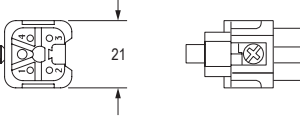
Screw connection

EN 61984 rating	10 A 230 / 400 V 4 kV 3
	10 A 400 / 690 V 4 kV 2
Rated voltage (UL / CSA)	600 V
Insulation resistance	≥ 10 GΩ
Contact resistance	≤ 2 mΩ
Ambient temperature limit	-40 °C ... +180 °C
Mechanical life (cycles)	≥ 500

CE UK EAC



ECBT2.E115072 | ECBT8.E115072

Item	Description	Part No.	Dimension
	3 poles male inserts with male contacts Use at temperatures up to 180 °C	CKM 03 RY	
	3 poles female inserts with female contacts Use at temperatures up to 180 °C Can be mounted into the straight bulkhead housings CK I from the rear	CKF 03 RY	
	4 poles male inserts with male contacts Use at temperatures up to 180 °C	CKM 04 RY	
	4 poles female inserts with female contacts Use at temperatures up to 180 °C Can be mounted into the straight bulkhead housings CK I from the rear	CKF 04 RY	

Materials

Insert	polyphenylene sulphide (PPS)
UL 94 flame rating	V-0
Colour	brown
Contacts	built-in, copper alloy, silver ● plated

Wiring information

Wires cross sectional area	0,5 mm ² - 2,5 mm ² (AWG 18-14)
Stripping length	6 mm
Terminal screw torque	0,5 Nm (4.4 lb.in)

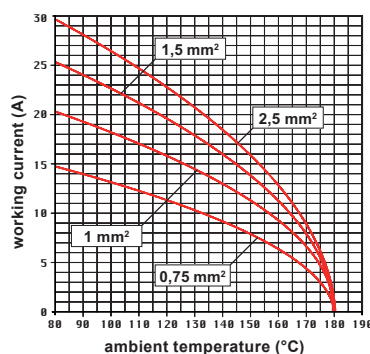
Compact 21.21 enclosures

Pages

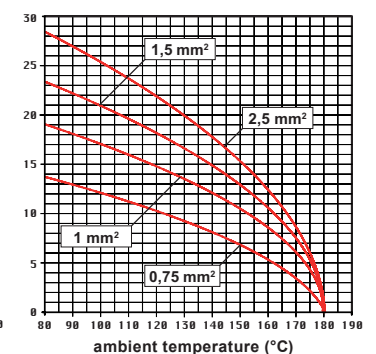
Specialized Applications

180 °C High Temperatures	I.16-17
--------------------------	---------

CK RY 03 inserts max. current load derating diagram



CK RY 04 inserts max. current load derating diagram





CNE 06 RY

16 A 500 V

size **44.27**

6 poles + ⊕

Screw connection

EN 61984 rating	16 A 500 V 6 kV 3
	16 A 400 / 690 V 6 kV 2
Rated voltage (UL / CSA)	600 V
Insulation resistance	≥ 10 GΩ
Contact resistance	≤ 1 mΩ
Ambient temperature limit	-40 °C ... +180 °C
Mechanical life (cycles)	≥ 500



ALUS ECBT2.E115072 | ECBT8.E115072

Item	Description	Part No.	Dimension
	Male inserts with male contacts With pressure plate For unprepared conductors Use at temperatures up to 180 °C	CNEM 06 RY	
	Female inserts with female contacts With pressure plate For unprepared conductors Use at temperatures up to 180 °C	CNEF 06 RY	

Materials

Insert	polyphenylene sulphide (PPS)
UL 94 flame rating	V-0
Colour	brown
Contacts	built-in, copper alloy, silver ● plated

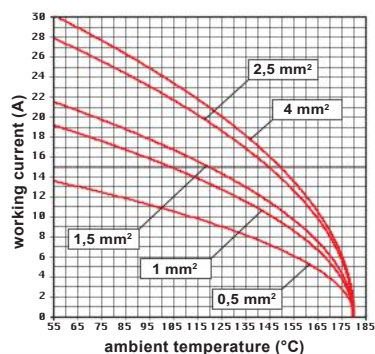
Wiring information

Wires cross sectional area	0,5 mm ² - 4 mm ² (AWG 20-12)
unprepared	7 mm
Stripping length	7 mm
Terminal screw torque	0,5 Nm (4.4 lb.in)



Enclosures size 44.27	Pages
Specialized Applications	
180 °C High Temperatures	.18-19

CNE 06 RY inserts max. current load derating diagram



CNE 10 RY

16 A 500 V

size **57.27**


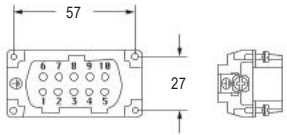

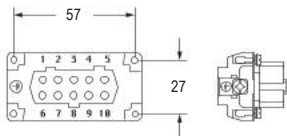
10 poles + ⊕

Screw connection

EN 61984 rating	16 A 500 V 6 kV 3
	16 A 400 / 690 V 6 kV 2
Rated voltage (UL / CSA)	600 V
Insulation resistance	≥ 10 GΩ
Contact resistance	≤ 1 mΩ
Ambient temperature limit	-40 °C ... +180 °C
Mechanical life (cycles)	≥ 500



ALUS ECBT2.E115072 | ECBT8.E115072

Item	Description	Part No.	Dimension
	Male inserts with male contacts With pressure plate For unprepared conductors Use at temperatures up to 180 °C	CNEM 10 RY	
	Female inserts with female contacts With pressure plate For unprepared conductors Use at temperatures up to 180 °C	CNEF 10 RY	

Materials

Insert	polyphenylene sulphide (PPS)
UL 94 flame rating	V-0
Colour	brown
Contacts	built-in, copper alloy, silver ● plated

Wiring information

Wires cross sectional area	0,5 mm ² - 4 mm ² (AWG 20-12)
unprepared	7 mm
Stripping length	7 mm
Terminal screw torque	0,5 Nm (4.4 lb.in)

> For unprepared conductors
with pressure plate



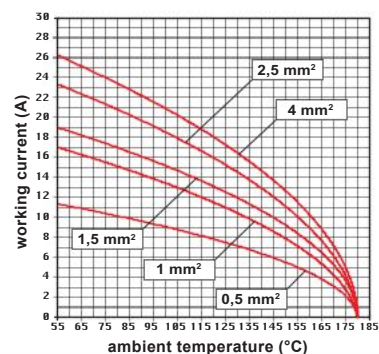
Enclosures size 57.27

Pages

Specialized Applications

180 °C High Temperatures

[.20-21](#)



CNE 10 RY inserts max. current load derating diagram



CNE 16 RY

16 A 500 V

size **77.27**


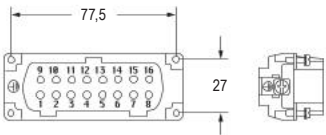

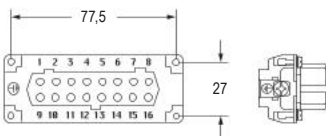
16 poles + ⊕

Screw connection

EN 61984 rating	16 A 500 V 6 kV 3
	16 A 400 / 690 V 6 kV 2
Rated voltage (UL / CSA)	600 V
Insulation resistance	≥ 10 GΩ
Contact resistance	≤ 1 mΩ
Ambient temperature limit	-40 °C ... +180 °C
Mechanical life (cycles)	≥ 500



ALUS ECBT2.E115072 | ECBT8.E115072

Item	Description	Part No.	Dimension
	Male inserts with male contacts With pressure plate For unprepared conductors Use at temperatures up to 180 °C	CNEM 16 RY	
	Female inserts with female contacts With pressure plate For unprepared conductors Use at temperatures up to 180 °C	CNEF 16 RY	

Materials

Insert	polyphenylene sulphide (PPS)
UL 94 flame rating	V-0
Colour	brown
Contacts	built-in, copper alloy, silver ● plated

Wiring information

Wires cross sectional area	0,5 mm ² - 4 mm ² (AWG 20-12)
unprepared	7 mm
Stripping length	7 mm
Terminal screw torque	0,5 Nm (4.4 lb.in)

> For unprepared conductors with pressure plate

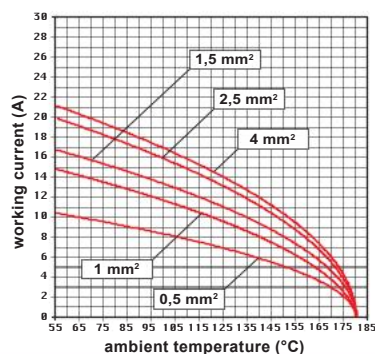


Enclosures size 77.27 and 77.62

Pages [22-23](#) [26](#)

Specialized Applications

180 °C High Temperatures	22-23	26
--------------------------	-----------------------	--------------------



CNE 16 RY inserts max. current load derating diagram

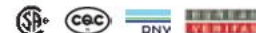
CNE 24 RY

16 A 500 Vsize **104.27****24 poles + ⊕**


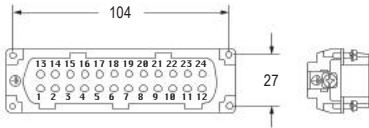

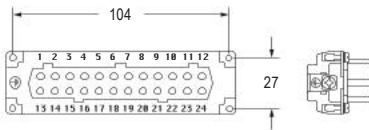
Screw connection

EN 61984 rating	16 A 500 V 6 kV 3
	16 A 400 / 690 V 6 kV 2
Rated voltage (UL / CSA)	600 V
Insulation resistance	≥ 10 GΩ
Contact resistance	≤ 1 mΩ
Ambient temperature limit	-40 °C ... +180 °C
Mechanical life (cycles)	≥ 500

CE UK EAC



CRAIUS ECBT2.E115072 | ECBT8.E115072

Item	Description	Part No.	Dimension
	Male inserts with male contacts With pressure plate For unprepared conductors Use at temperatures up to 180 °C	CNEM 24 RY	
	Female inserts with female contacts With pressure plate For unprepared conductors Use at temperatures up to 180 °C	CNEF 24 RY	

Materials

Insert	polyphenylene sulphide (PPS)
UL 94 flame rating	V-0
Colour	brown
Contacts	built-in, copper alloy, silver ● plated

Wiring information

Wires cross sectional area	0,5 mm ² - 4 mm ² (AWG 20-12)
unprepared	7 mm
Stripping length	7 mm
Terminal screw torque	0,5 Nm (4.4 lb.in)

> For unprepared conductors
with pressure plate

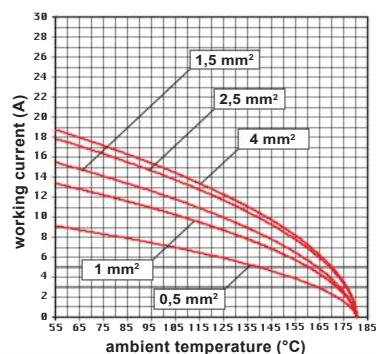


Enclosures size 104.27

Pages

Specialized Applications

180 °C High Temperatures

[.24-25](#)

CNE 24 RY inserts max. current load derating diagram



CNE 24 RY + CNE 24 RYN

16 A 500 V

size **104.62**


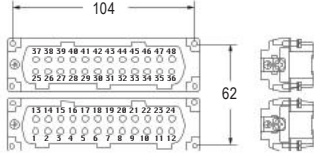

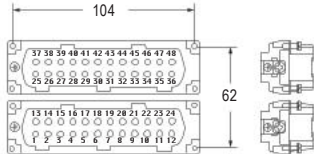
48 poles + ⊕

Screw connection

EN 61984 rating	16 A 500 V 6 kV 3
	16 A 400 / 690 V 6 kV 2
Rated voltage (UL / CSA)	600 V
Insulation resistance	≥ 10 GΩ
Contact resistance	≤ 1 mΩ
Ambient temperature limit	-40 °C ... +180 °C
Mechanical life (cycles)	≥ 500



ALUS ECBT2.E115072 | ECBT8.E115072

Item	Description	Part No.	Dimension
	Male inserts, No. (1-24) Male inserts, No. (25-48) With pressure plate For unprepared conductors Use at temperatures up to 180 °C	CNEM 24 RY CNEM 24 RYN	
	Female inserts, No. (1-24) Female inserts, No. (25-48) With pressure plate For unprepared conductors Use at temperatures up to 180 °C	CNEF 24 RY CNEF 24 RYN	

Materials

Insert	polyphenylene sulphide (PPS)
UL 94 flame rating	V-0
Colour	brown
Contacts	built-in, copper alloy, silver ● plated

Wiring information

Wires cross sectional area	0,5 mm ² - 4 mm ² (AWG 20-12)
unprepared	7 mm
Stripping length	7 mm
Terminal screw torque	0,5 Nm (4.4 lb.in)

> For unprepared conductors with pressure plate



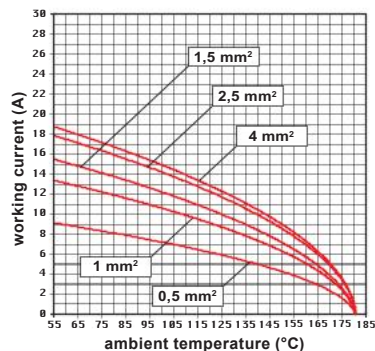
Enclosures size 104.62

Pages

Specialized Applications

180 °C High Temperatures

.27



CNE 24 RY inserts max. current load derating diagram

CP 06 RY

35 A 400/690 V

size **77.27**

6 poles +

Screw connection

EN 61984 rating	35 A 400 / 690 V 6 kV 3
Rated voltage (UL / CSA)	600 V
Insulation resistance	≥ 10 GΩ
Contact resistance	≤ 0,5 mΩ
Ambient temperature limit	-40 °C ... +180 °C
Mechanical life (cycles)	≥ 500

CE UK EAC

ECBT2.E115072 | ECBT8.E115072

Item	Description	Part No.	Dimension
	Male inserts for male contacts With pressure plate For unprepared conductors Use at temperatures up to 180 °C	CPM 06 RY	
	Female inserts for female contacts With pressure plate For unprepared conductors Use at temperatures up to 180 °C	CPF 06 RY	

Materials

Insert	polyphenylene sulphide (PPS)
UL 94 flame rating	V-0
Colour	brown
Contacts	built-in, copper alloy, silver ● plated

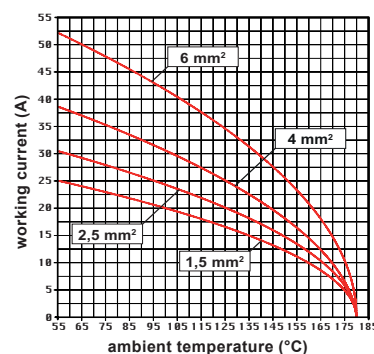
Wiring information

Wires cross sectional area unprepared	0,75 mm ² - 6 mm ² (AWG 18-10)
Stripping length	10,5 mm
Terminal screw torque	1,2 Nm (10.7 lb.in)

> For unprepared conductors with pressure plate



Enclosures size 77.27 and 77.62	Pages	Pages	
Specialized Applications			
180 °C High Temperatures	I.22-23	I.26	



CP RY 06 inserts max. current load derating diagram



CX 4/0 RY

80 A 830 V

size **77.27**

4 poles + ⊕

Screw connection

EN 61984 rating	80 A 830 V 8 kV 3
Rated voltage (UL / CSA)	600 V
Insulation resistance	≥ 10 GΩ
Contact resistance	≤ 0,3 mΩ
Ambient temperature limit	-40 °C ... +180 °C
Mechanical life (cycles)	≥ 500

CE UK EAC



ECBT2.E115072 | ECBT8.E115072

Item	Description	Part No.	Dimension
	Male inserts for male contacts Use at temperatures up to 180 °C	CXM 4/0 RY	
	Female inserts for female contacts Use at temperatures up to 180 °C	CXF 4/0 RY	

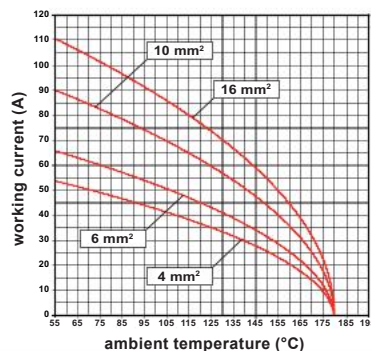
Materials

Insert	polyphenylene sulphide (PPS)
UL 94 flame rating	V-0
Colour	brown
Contacts	built-in, copper alloy, silver ● plated

Wiring information

Wires cross sectional area	4 mm ² - 16 mm ² (AWG 12-6)
Stripping length	14 mm
Terminal screw torque	2,5 Nm (22.1 lb.in)

Enclosures size 77.27 and 77.62	Pages	Pages
Specialized Applications		
180 °C High Temperatures	.22-23	.26



CX 4/0 RY inserts max. current load derating diagram

Can be used in bulkhead mounting housing or in high construction housing or in high construction hoods.

CX 4/2 RY


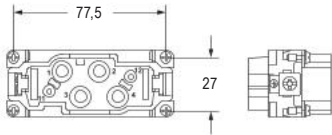

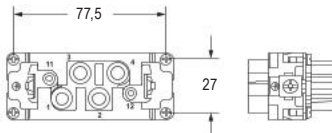
80 A 830 V / 16 A 400 Vsize **77.27**
4 / 2 poles + ⊕

Screw connection

EN 61984 rating	80 A 830 V 8 kV 3
	16 A 400 V 6 kV 3 / 16 A 400 / 690 V 6 kV 2
Rated voltage (UL / CSA)	600 V
Insulation resistance	≥ 10 GΩ
Contact resistance	80 A (4 poles) ≤ 0,3 mΩ
	16 A (2 poles) ≤ 1 mΩ
Ambient temperature limit	-40 °C ... +180 °C
Mechanical life (cycles)	≥ 500



ECBT2.E115072 | ECBT8.E115072

Item	Description	Part No.	Dimension
	Male inserts for male contacts Use at temperatures up to 180 °C	CXM 4/2 RY	
	Female inserts for female contacts Use at temperatures up to 180 °C	CXF 4/2 RY	

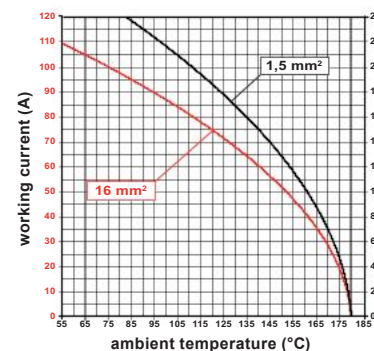
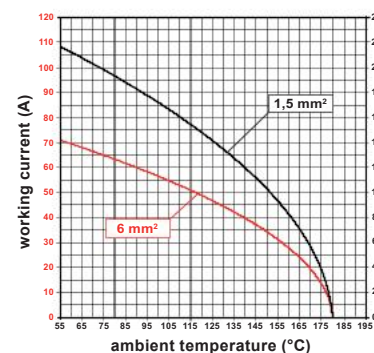
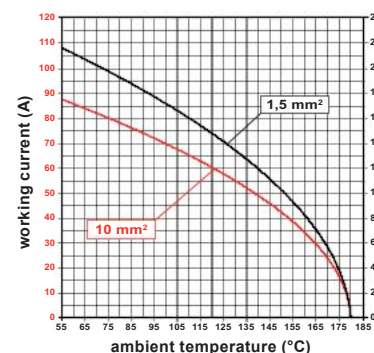
Materials

Insert	polyphenylene sulphide (PPS)
UL 94 flame rating	V-0
Colour	brown
Contacts	built-in, copper alloy, silver ● plated

Wiring information

Wires cross sectional area	
- 80 A contacts	4 mm ² - 16 mm ² (AWG 12-6)
- 16 A contacts	0,25 mm ² - 2,5 mm ² (AWG 24-14)
Stripping length	
- 80 A contacts	14 mm
- 16 A contacts	7 mm
Terminal screw torque	
- 80 A contacts	2,5 Nm (22.1 lb.in)
- 16 A contacts	0,5 Nm (4.4 lb.in)

CX 4/2 RY inserts max. current load derating diagrams



Enclosures size 77.27 and 77.62

Pages [Pages](#) [Pages](#) [Pages](#)

Specialized Applications

180 °C High Temperatures

[.22-23](#) [.26](#)

Can be used in bulkhead mounting housing or in high construction housing or in high construction hoods.

Any cross-sectional area on the signal side higher than that combined to the relevant cross-sectional area on the power side may be used, but with the derating curve for the cross-sectional area given as combined to that on the power side.

CX 4/8 RY

80 A 400 V / 16 A 230/400 V

size **104.27**
4 / 8 poles + ⊕


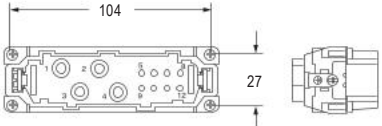

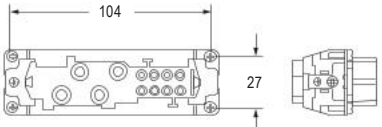
Screw connection

EN 61984 rating	80 A 400 V 6 kV 3 / 80 A 400 / 690 V 6 kV 2
	16 A 230 / 400 V 4 kV 3 / 16 A 400 V 4 kV 2
Rated voltage (UL / CSA)	600 V
Insulation resistance	≥ 10 GΩ
Contact resistance	80 A (4 poles) ≤ 0,3 mΩ
	16 A (8 poles) ≤ 1 mΩ
Ambient temperature limit	-40 °C ... +180 °C
Mechanical life (cycles)	≥ 500

CE UK EAC



ECBT2.E115072 | ECBT8.E115072

Item	Description	Part No.	Dimension
	Male inserts for male contacts Use at temperatures up to 180 °C	CXM 4/8 RY	
	Female inserts for female contacts Use at temperatures up to 180 °C	CXF 4/8 RY	

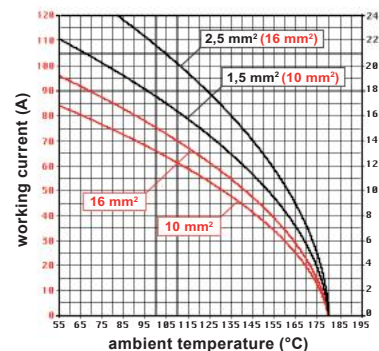
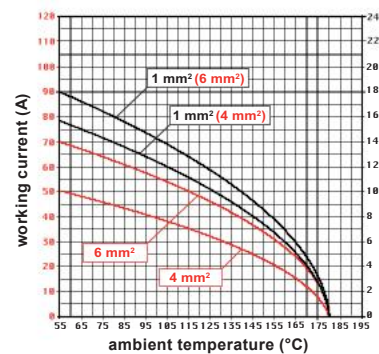
Materials

Insert	polyphenylene sulphide (PPS)
UL 94 flame rating	V-0
Colour	brown
Contacts	built-in, copper alloy, silver ● plated

Wiring information

Wires cross sectional area	
- 80 A contacts	4 mm ² - 16 mm ² (AWG 12-6)
- 16 A contacts	0,25 mm ² - 2,5 mm ² (AWG 24-14)
Stripping length	
- 80 A contacts	14 mm
- 16 A contacts	7 mm
Terminal screw torque	
- 80 A contacts	2,5 Nm (22.1 lb.in)
- 16 A contacts	0,5 Nm (4.4 lb.in)

CX 4/8 RY inserts max. current load derating diagrams



Enclosures size 104.27 and 104.62

Pages [Pages](#) [Pages](#) [Pages](#)

Specialized Applications

180 °C High Temperatures

[.24-25](#) [.27](#)

Can be used in bulkhead mounting housing or in high construction housing or in high construction hoods.

Any cross-sectional area in the signal side higher than that combined to the relevant cross-sectional area on the power side may be used, but with the derating curve for the cross-sectional area given as combined to that on the power side.

Any cross-sectional area in the signal side lower than that combined to the relevant cross-sectional area on the power side (e.g. 1 mm² signal with 16 mm² power) may be used at the current indicated to for the signal cross-sectional area belonging to the closest lower cross-sectional area on the power side (i.e. the 1 mm² curve combined to the 6 mm² power section).

The derating curves for the connector's
power and **signal** poles in the diagrams above are valid for the following combinations:

- **power** 4 mm² with **signal** 1 mm²;
- **power** 6 mm² with **signal** 1 mm²;
- **power** 10 or 6 mm² with **signal** 1,5 mm²;
- **power** 16 mm² with **signal** 2,5 mm².



180 °C enclosures

The heat shield



Series specifically developed for industrial applications where the temperatures can reach up to 180 °C.


The aluminium die-cast unpainted enclosures are equipped with stainless steel levers and FKM red gaskets (except MKAXR IF, MKAXXR IF \varnothing 32 mm O-ring and MHPR 48 L40 /LS40 \varnothing 40 mm O-ring).

Available in the sizes 21.21, 44.27, 57.27, 77.27, 104.27, 77.62, and 104.62, to be used in combination with the ILME high-temperature connector inserts made by self-extinguishing thermoplastic material ("PPS" polyphenylene sulphide).

SUM-UP

- > Enclosure body made of die-cast aluminium alloy.
- > Flange and interface sealing gaskets (as applicable) in FKM, anti-ageing heat-resistant fluoroelastomer.
- > Stainless steel V-TYPE locking mechanism for 44.27, 57.27, 77.27, and 104.27 size housings.
- > Single-block locking lever handles in stainless steel (for 21.21 sized CKA..R /MKA..R, 44.27 sized CV..R /MV..R, 77.62 sized CH..R 32.. /MHP..R 32.. and 104.62 sized CH..R 48.. /MHP..R 48.. versions).

✔ Markings and Approvals

-  certified for USA and Canada for Type 12 (indoor use) and Type 4 protection ratings, marked on the packaging label
- IP44 (size 21.21), IP65 (other sizes) degree of protection according to EN IEC 60529.



180 °C series – Heat shield enclosures

size **21.21**

Housings and hoods – 1 lever

Specialized Applications



EN 60529	IP44
UL 50 / UL 50E	Type 12
Ambient temperature limits	-40 °C ... +180 °C
Mechanical life (cycles)	≥ 500

CE UK CA



cURus ECBT2.E115072 | ECBT8.E115072

Item	Description	Part No.	Entry	Dimension
	Bulkhead mounting housings, 1 stainless steel lever	CKAXR 03 I		
	Angled bulkhead mounting housings, 1 stainless steel lever	CKAXR 03 IA		
	Angled bulkhead mounting housings, 1 stainless steel lever, with cable entry	With gasket MKAXR IAP20	M20	
		Without gasket MKAXR AP20	M20	
	Hood, 1 stainless steel lever, top entry	MKAXR VG20	M20	
	Bulkhead mounting housings, with 1 stainless steel lever or with 1 stainless steel rigid lever, with M32 fixing thread	With stainless steel lever MKAXR IF	M32	
	CQC, DNV, BV and cURus pending only for MKAXXR IF	With stainless steel rigid lever MKAXXR IF	M32	

Inserts size 21.21	Poles	Pages
CK 03 RY 10 A	3 + ⊕	I.4
CK 04 RY 10 A	4 + ⊕	I.4



180 °C series – Heat shield enclosures

size **21.21**

Hoods – 2 pegs


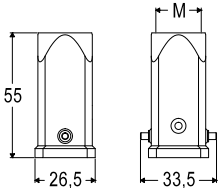

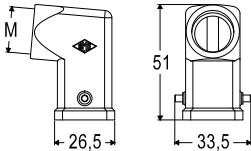
Specialized Applications



EN 60529	IP44
UL 50 / UL 50E	Type 12
Ambient temperature limits	-40 °C ... +180 °C
Mechanical life (cycles)	≥ 500



ALUS ECBT2.E115072 | ECBT8.E115072

Item	Description	Part No.	Entry	Dimension
	Hoods, with 2 pegs, top entry	MKAR V20	M20	
	Hoods, with 2 pegs, side entry	MKAR VA20	M20	

Inserts size 21.21	Poles	Pages
CK 03 RY 10 A	3 + ⊕	I.4
CK 04 RY 10 A	4 + ⊕	I.4



180 °C series – Heat shield enclosures

size **44.27**

Housings – 1 lever – with gasket


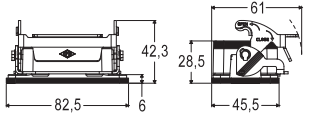

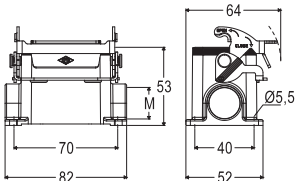

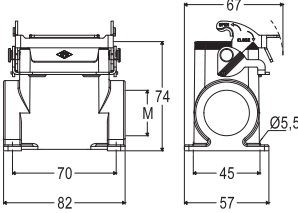
Specialized Applications



EN 60529	IP65
UL 50 / UL 50E	Type 12 / 4
Ambient temperature limits	-40 °C ... +180 °C
Mechanical life (cycles)	≥ 500

CE UK CA

C[®] A[®] US ECBT2.E115072 | ECBT8.E115072

Item	Description	Part No.	Entry	Dimension
	Bulkhead mounting housings, 1 lever and gasket	CVIR 06 L		
	Surface mounting housings, 1 lever and gasket	MVPR 06 L20	M20	
	Surface mounting housings, 1 lever and gasket, high construction	MVAPR 06 L32	M32	

Inserts size 44.27	Poles	Pages
CNE RY	16 A	6 + ☺ 1.5

180 °C series – Heat shield enclosures

size **44.27**

Hoods and covers – 2 pegs – without gasket


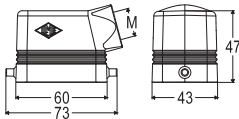

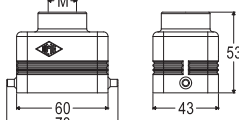

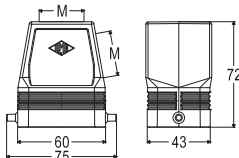

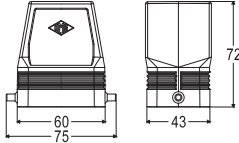

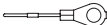
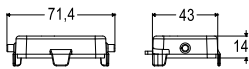
Specialized
Applications

CE UK



EN 60529	IP65
UL 50 / UL 50E	Type 12 / 4
Ambient temperature limits	-40 °C ... +180 °C
Mechanical life (cycles)	≥ 500

C^{AL}US[®] ECBT2.E115072 | ECBT8.E115072

Item	Description	Side entry	Top entry	Entry	Dimension
	Hoods, 2 pegs, without gasket, side entry	MHOR 06 L20		M20	
	Hoods, 2 pegs, without gasket, top entry		MHVR 06 L20	M20	
	Hoods, 2 pegs, without gasket, side or top entry, high construction	MFOR 06 L32	MFVR 06 L32	M32	
	Hoods, 2 pegs, without gasket, high construction, designed to be drilled	Without entry			
	Cover, 2 pegs, without gasket For enclosures with 1 lever and gasket with eyelet for housings 	Cover			

Inserts size 44.27	Poles	Pages
CNER Y	16 A	6 + ☉ 1.5


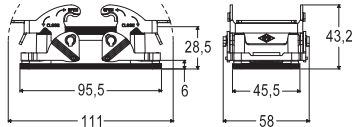

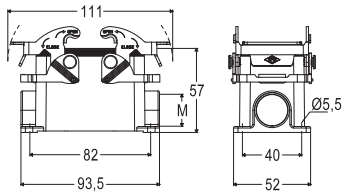

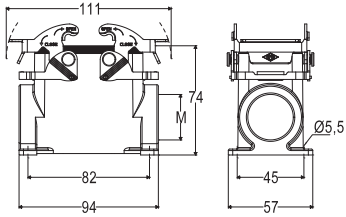


180 °C series – Heat shield enclosures

size **57.27****Housings – 2 levers – with gasket**Specialized
ApplicationsCE UK
CA

EN 60529	IP65
UL 50 / UL 50E	Type 12 / 4
Ambient temperature limits	-40 °C ... +180 °C
Mechanical life (cycles)	≥ 500

C[®] A[®] US ECBT2.E115072 | ECBT8.E115072

Item	Description	Part No.	Entry	Dimension
	Bulkhead mounting housings, 2 levers and gasket	CVIR 10		
	Surface mounting housings, 2 levers and gasket	MVPR 10.20	M20	
	Surface mounting housings, 2 levers and gasket, high construction	MVAPR 10.32	M32	

Inserts size 57.27	Poles	Pages
CNE RY	16 A	10 + ⊕ 1.6

180 °C series – Heat shield enclosures

size **57.27**

Hoods and covers – 4 pegs – without gasket


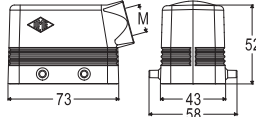

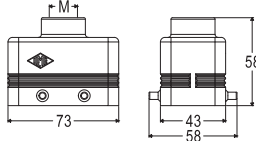

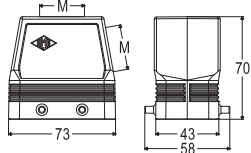

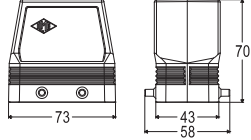

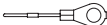
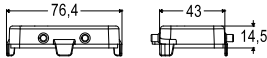
Specialized
Applications

CE UK



EN 60529	IP65
UL 50 / UL 50E	Type 12 / 4
Ambient temperature limits	-40 °C ... +180 °C
Mechanical life (cycles)	≥ 500

C^{AL}US[®] ECBT2.E115072 | ECBT8.E115072

Item	Description	Side entry	Top entry	Entry	Dimension
	Hoods, 4 pegs, without gasket, side entry	MHOR 10.20		M20	
	Hoods, 4 pegs, without gasket, top entry		MHVR 10.20	M20	
	Hoods, 4 pegs, without gasket, side or top entry, high construction	MFOR 10.32	MFVR 10.32	M32	
	Hoods, 4 pegs, without gasket, high construction, designed to be drilled	Without entry			
	Cover, 4 pegs, without gasket For enclosures with 2 levers and gasket with eyelet for housings 	Cover			

Inserts size 57.27	Poles	Pages
CNER Y	16 A	10 + ☉ 1.6


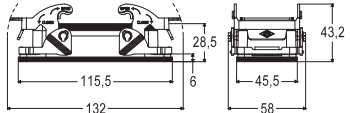

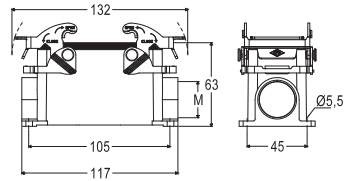

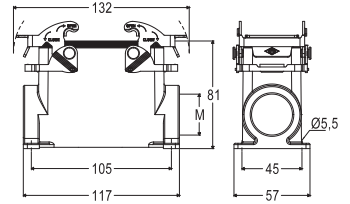


180 °C series – Heat shield enclosures

size **77.27****Housings – 2 levers – with gasket**Specialized
ApplicationsCE UK
CA

EN 60529	IP65
UL 50 / UL 50E	Type 12 / 4
Ambient temperature limits	-40 °C ... +180 °C
Mechanical life (cycles)	≥ 500

C[®]ALUS ECBT2.E115072 | ECBT8.E115072

Item	Description	Part No.	Entry	Dimension
	Bulkhead mounting housings, 2 levers and gasket	CVIR 16		
	Surface mounting housings, 2 levers and gasket	MVPR 16.25	M25	
	Surface mounting housings, 2 levers and gasket, high construction	MVAPR 16.32	M32	

Inserts size 77.27	Poles	Pages
CNE RY 16 A	16 + ⊕	I.7
CP RY 35 A	6 + ⊕	I.10
CX RY 80 A	4 + ⊕	I.11
CX RY 80A / 16 A	4/2 + ⊕	I.12



180 °C series – Heat shield enclosures

size **77.27**

Hoods and covers – 4 pegs – without gasket

Specialized Applications

CE UK



EN 60529	IP65
UL 50 / UL 50E	Type 12 / 4
Ambient temperature limits	-40 °C ... +180 °C
Mechanical life (cycles)	≥ 500

ECBT2.E115072 | ECBT8.E115072

Item	Description	Side entry	Top entry	Entry	Dimension
	Hoods, 4 pegs, without gasket, side entry	MHOR 16.25		M25	
	Hoods, 4 pegs, without gasket, top entry		MHVR 16.25	M25	
	Hoods, 4 pegs, without gasket, side or top entry, high construction	MFOR 16.40	MFVR 16.40	M40	
	Hoods, 4 pegs, without gasket, high construction, designed to be drilled		Without entry		CACR 16
	Cover, 4 pegs, without gasket For enclosures with 2 levers and gasket with eyelet for housings		Cover		CHCR 16

Inserts size 77.27	Poles	Pages	
CNE RY	16 A	16 + ⊕	I.7
CP RY	35 A	6 + ⊕	I.10
CX RY	80 A	4 + ⊕	I.11
CX RY	80A / 16 A	4/2 + ⊕	I.12



180 °C series – Heat shield enclosures

size **104.27****Housings – 2 levers – with gasket**


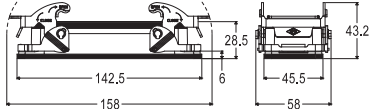

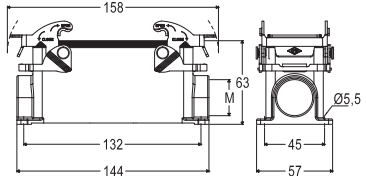

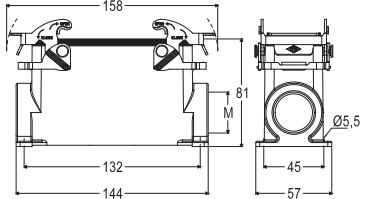
Specialized Applications



EN 60529	IP65
UL 50 / UL 50E	Type 12 / 4
Ambient temperature limits	-40 °C ... +180 °C
Mechanical life (cycles)	≥ 500

CE UK CA

CIRIUS[®] ECBT2.E115072 | ECBT8.E115072

Item	Description	Part No.	Entry	Dimension
	Bulkhead mounting housings, 2 levers and gasket	CVIR 24		
	Surface mounting housings, 2 levers and gasket	MVPR 24.25	M25	
	Surface mounting housings, 2 levers and gasket, high construction	MVAPR 24.32 MVAPR 24.40	M32 M40	

Inserts size 104.27	Poles	Pages
CNE RY 16 A	24 + ⊕	I.8
CX RY 80 A / 16 A	4/8 + ⊕	I.13



180 °C series – Heat shield enclosures

size **104.27**

Hoods and covers – 4 pegs – without gasket

Specialized Applications

CE UK



EN 60529	IP65
UL 50 / UL 50E	Type 12 / 4
Ambient temperature limits	-40 °C ... +180 °C
Mechanical life (cycles)	≥ 500

ECBT2.E115072 | ECBT8.E115072

Item	Description	Side entry	Top entry	Entry	Dimension
	Hoods, 4 pegs, without gasket, side entry	MHOR 24.25 MHOR 24.32		M25 M32	
	Hoods, 4 pegs, without gasket, top entry		MHVR 24.25	M25	
	Hoods, 4 pegs, without gasket, side or top entry, high construction	MFOR 24.32 MFOR 24.40	MFVR 24.40	M32 M40	
	Hoods, 4 pegs, without gasket, high construction, designed to be drilled		Without entry		
	Cover, 4 pegs, without gasket For enclosures with 2 levers and gasket with eyelet for housings		Cover		

Inserts size 104.27	Poles	Pages	
CNE RY	16 A	24 + ⊕	I.8
CX RY	80 A / 16 A	4/8 + ⊕	I.13



180 °C series – Heat shield enclosures


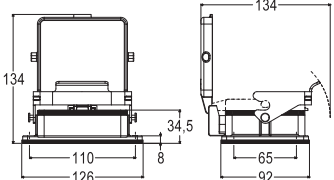

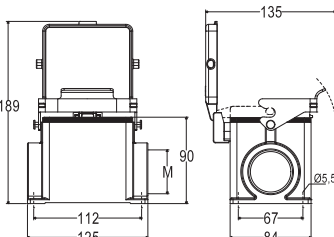

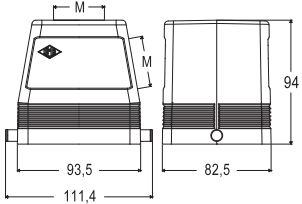
size **77.62**

Housings and hoods

Specialized
ApplicationsCE UK
CA

EN 60529	IP65
UL 50 / UL 50E	Type 12 / 4
Ambient temperature limits	-40 °C ... +180 °C
Mechanical life (cycles)	≥ 500

C[®]ALUS ECBT2.E115072 | ECBT8.E115072

Item	Description	Part No.	With cover	Entry	Dimension
	Bulkhead mounting housings, 1 lever and gasket, with or without metal cover	CHIR 32 L	CHIR 32 LS		
	Surface mounting housings, 1 lever and gasket, high construction, with or without metal cover	MHPR 32 L40	MHPR 32 LS40	M40	
	Hoods, 2 pegs, without gasket, side or top entry, high construction	Side entry MFOR 32 L40	Top entry MFVR 32 L40	M40	

Inserts size 2 × (77.27)	Poles	Pages
CNE RY 16 A	32 + ⊕	I.7
CP RY 35 A	12 + ⊕	I.10
CX RY 80 A	8 + ⊕	I.11
CX RY 80 A / 16 A	4/2 + ⊕	I.12



180 °C series – Heat shield enclosures

size **104.62**

Housings and hoods

Specialized Applications

CE UK



EN 60529	IP65
UL 50 / UL 50E	Type 12 / 4
Ambient temperature limits	-40 °C ... +180 °C
Mechanical life (cycles)	≥ 500

ECBT2.E115072 | ECBT8.E115072

Item	Description	Part No.	With cover	Entry	Dimension
	Bulkhead mounting housings, 1 lever and gasket, with or without metal cover	CHIR 48 L	CHIR 48 LS		
	Surface mounting housings, 1 lever and gasket, high construction, with or without metal cover	MHPR 48 L40	MHPR 48 LS40	M40 x 2	
	Hoods, 2 pegs, without gasket, side or top entry, high construction	Side entry MFOR 48 L40	Top entry MFVR 48 L40 MFVR 48 L63	M40 M63	

Inserts size 2 x (104.27)	Poles	Pages
CNE RY + RYN	16 A	48 + ⊕
CX RY	80 A / 16 A	4/8 + ⊕

CHIR.. – MHPR.. – MF..R

Panel cut-out drawings

For 180 °C series bulkhead mounting housings

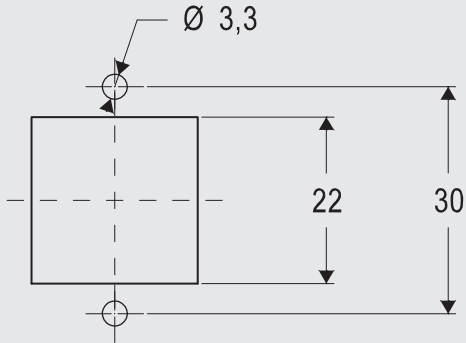
To guarantee the declared IP degree of protection of the housings reported in this catalogue, according to EN IEC 60529 or to the relevant Type rating per ANSI/UL 50 and 50E (for those products bearing approval to those ratings), the surface of the mounting panel must meet the following requirements (definitions are provided in ISO 4287 standard):

Waviness $Wt \leq 0,2$ mm over a distance of 200 mm
(measured on the panel without load)

Roughness $Ra \leq 16$ μm

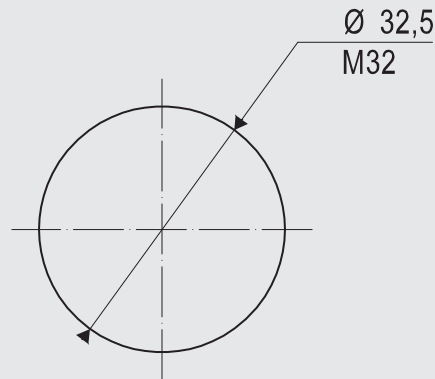
Scale 1:1

Size 21.21 fixing by 2 screws



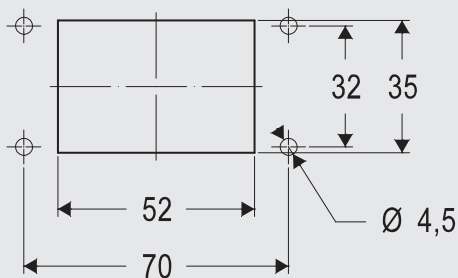
Required screws: 2
Screws size: M3
Recommended torque:
0,8 – 1,0 Nm / 7.1 – 8.9 lb.in

Size 21.21 with M32 fixing thread



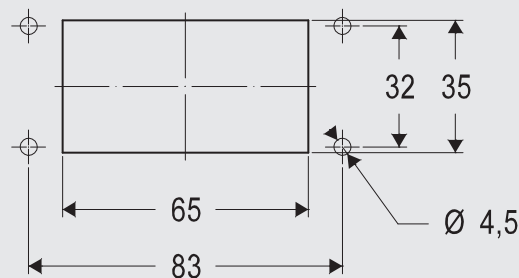
Scale 1:2

Size 44.27



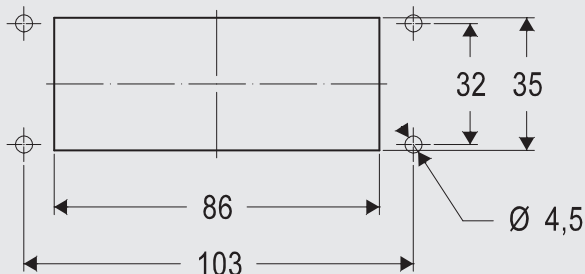
Required screws: 4
Screws size: M4
Recommended torque:
0,8 – 1,2 Nm / 7.1 – 10.6 lb.in

Size 57.27



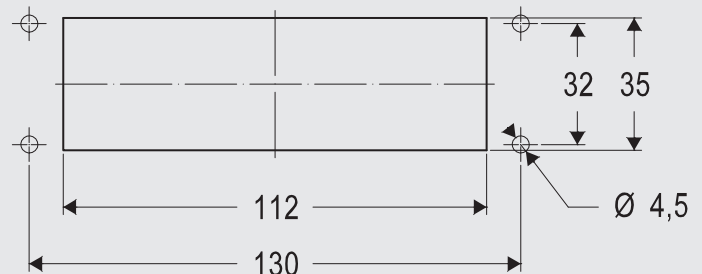
Required screws: 4
Screws size: M4
Recommended torque:
0,8 – 1,2 Nm / 7.1 – 10.6 lb.in

Size 77.27



Required screws: 4
Screws size: M4
Recommended torque:
0,8 – 1,2 Nm / 7.1 – 10.6 lb.in

Size 104.27



Required screws: 4
Screws size: M4
Recommended torque:
0,8 – 1,2 Nm / 7.1 – 10.6 lb.in

Notes: The values of tightening torque indicated above are just recommended values, that must be related – by the designer of the final application – to the resistance class of the screws (not included), with the assumption that the mounting panel is sufficiently rigid (stiff). If the deflection of the panel, under the effect of tightening the screws, is greater than 0,7 mm over a distance of 100 mm, it is

necessary to use the counter-flanges mentioned in our catalogue or the special flange gaskets available upon request (please contact our Sales Department).

Panel cut-out drawings

For 180 °C series bulkhead mounting housings

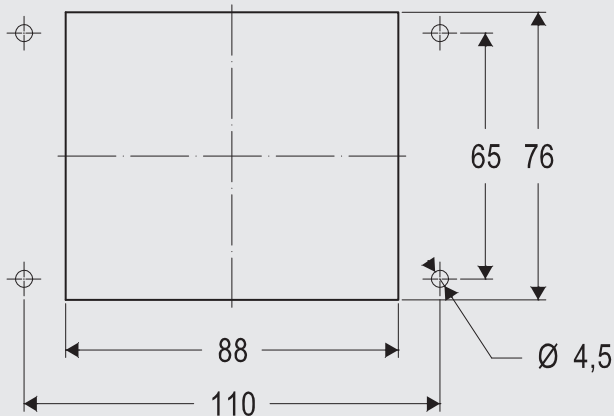
To guarantee the declared IP degree of protection of the housings reported in this catalogue, according to EN IEC 60529 or to the relevant Type rating per ANSI/UL 50 and 50E (for those products bearing approval to those ratings), the surface of the mounting panel must meet the following requirements (definitions are provided in ISO 4287 standard):

Waviness $W_t \leq 0,2$ mm over a distance of 200 mm
(measured on the panel without load)

Roughness $R_a \leq 16$ μm

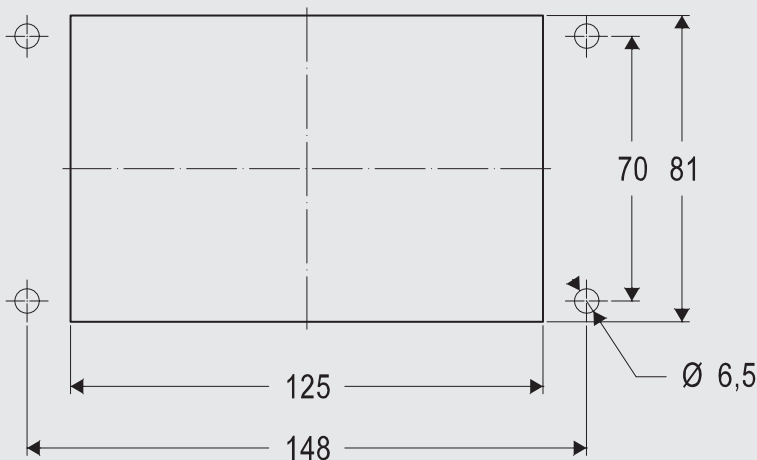
Scale 1:2

Size 77.62



Required screws: 4
Screws size: M4
Recommended torque:
1,2 – 1,8 Nm / 10.6 – 15.9 lb.in

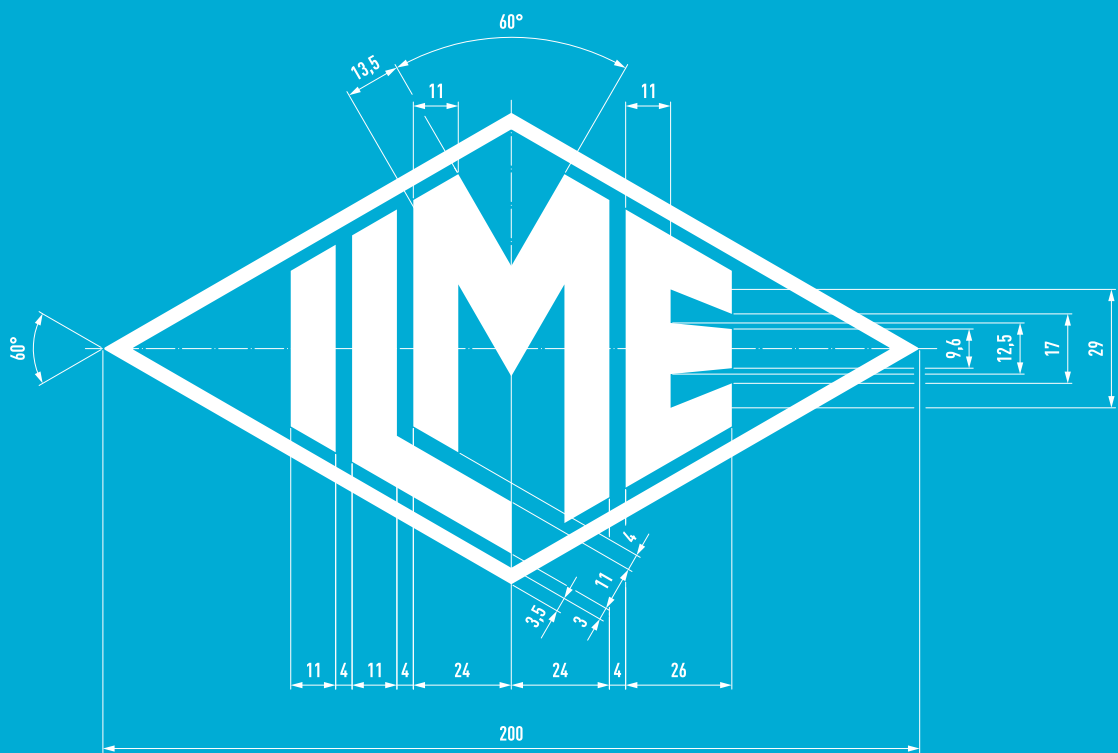
Size 104.62



Required screws: 4
Screws size: M6
Recommended torque:
3,0 – 3,6 Nm / 26.6 – 31.9 lb.in

Notes: The values of tightening torque indicated above are just recommended values, that must be related – by the designer of the final application – to the resistance class of the screws (not included), with the assumption that the mounting panel is sufficiently rigid (stiff). If the deflection of the panel, under the effect of tightening the screws, is greater than 0,7 mm over a distance of 100 mm, it is

necessary to use the counter-flanges mentioned in our catalogue or the special flange gaskets available upon request (please contact our Sales Department).



GENERAL CATALOGUE

Appendix

Contents

Recommended tightening torque	J.2
Range of conductor cross-sectional area and stripping length	J.4
Load curves	J.5
Degree of protection	J.6
Changeover from Pg threads to Metric	J.7
T-TYPE enclosures resistance to chemicals comparison table	J.8
Dimensioning of clearances and creepage distances	J.10
EU environmental legislation	J.16
Fire protection standards for railway applications	J.17
Standards and Certifications	J.19
Specifications	J.19
INDEX OF PART NUMBERS	J.20

RECOMMENDED TIGHTENING TORQUE

- Insert terminal screws, including PE terminal and fixing screws
- Axial screw inserts, MIXO series CX 02 4A / CX 02 4B
- Enclosures assembly screws
- Enclosures locking screws

Insert terminal screws, including PE terminal and fixing screws

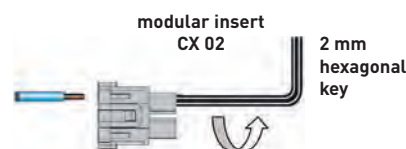
Increasing the tightening torque of terminal screws does not considerably improve the contact resistance. The screw torques are selected according to standard EN 60999-1, to provide excellent mechanical, thermal and electric behaviour. The conductor or terminal may be damaged if the recommended values are significantly exceeded.

Screw size	Connector type	Recommended tightening torque		Recommended size of screwdriver
		Nm	lb.in	
LINE TERMINALS				
M2,5	CT 40, 64	0,4	3.5	0,5 × 3
M2,6	CT 06..24	0,4	3.5	0,5 × 3
M3	CK	0,5	4.4	0,5 × 3
M3	CDA	0,5	4.4	Ph0 or 0,6 × 3,5
M3	CNE, CME	0,5	4.4	Ph0 or 0,8 × 4
M3	CX 4/2, CX 4/8 (16A)	0,5	4.4	0,6 × 3,5
M3	CX 4/8 Q (16A)	0,5	4.4	Ph0
M4	CP	1,2	10.6	Ph1 or 0,8 × 4
M7	CX 02 4A /4B	1,5 – 2	13.3 – 17.7	2 mm hex
M6	CX 4/.. (80A)	2,5	22.1	1,0 × 5,5
M6	CX 01 YA /YPEA (for tubular cable lug)	3	26.5	Torx® T30
M8	CX 01 30A /30PEA (for tubular cable lug)	10	88.5	Torx® T45
PE TERMINAL				
M3	CK, CQ 05, RQ 05, CQ 07, CQ 12	0,5	4.4	0,5 × 3
M4	all series except CD 15, CD 25, CDA, CDC, CSAH, MIXO	1,2	10.6	Ph2 or 1,0 × 5,5
M3,5	series CD 15, CD 25, CDA, CDC, CSAH	0,8	7.1	Ph1 or 0,8 × 5,5
M3	small PE terminal, MIXO frames series	0,5	4.4	Ph1 or 1,0 × 4,5
M4	large PE terminal, MIXO frames series	1,2	10.6	Ph1 or 1,0 × 5,5
M4	PE terminal, MIXO ONE and MIXO TWO enclosures	1,2	10.6	Ph1 or 1,0 × 5,5
FASTENING SCREWS				
M3	CK, CKS, CKSH, CD 07, CDY 07, CD 08, CDY 08, CQ 05, CQY 05, RQ 05, CQ 07, CQ 12, CQ 21, CQ4 02 /02 H, CQ4 03 /03/2, CJ KF /KM, CJK 8FT /8MT /CJK 8IFT /8IMT /8B IFT /8P IFT, CJK 8M, CUK 2FT /3FT, CLK 04 SC, CX 1/2 BD	0,5	4.4	Ph1 or 0,8 × 5,5
M3	assembly screws MIXO CX 01 GPE	0,5	4.4	Ph1 or 0,8 × 4
M3	screw for fastening inserts or frames to enclosures of all series except T-TYPE, CK-MK, CKA-MKA, RKA, CQ-MQ 08, MIXO ONE and MIXO TWO	0,8	7.1	Ph1 or 0,8 × 4
Ø 2,9	screws for fastening 32.13 inserts CQ 04/2, CQ 08, CQ 08E, CQY 08E, CQ 17 to CQ-MQ 08 and CQA-MQA 08 enclosures	0,7	6.2	Ph1
M3	screw for fastening inserts to T-TYPE enclosures	0,5	4.4	Ph1 or 0,8 × 4
Ø 2,9	series MIXO ONE enclosures, assembly of top and bottom parts	0,8	7.1	Ph1
	series MIXO TWO enclosures	0,8 – 1,2	7.1 – 10.6	3 mm hex
M4	CYR 16.3, CYR 24.4 cable pass-through hoods, assembly of two halves	1,2	10.6	Ph2 or 1,0 × 5,5
M4	CYR 16 in-line joint, assembly of two halves and mounting of two bulkhead mounting housings size 77.27	1,2	10.6	Ph2 or 1,0 × 5,5
M5	series BIG enclosures, assembly of top and bottom parts	1,0	8.8	Ph2

Axial screw inserts, MIXO series CX 02 4A / CX 02 4B

The connections of the conductors to the female and male inserts are made via axial screw. Fully insert the stripped wire in the back of the contact (axial screw terminals are supplied fully opened); while holding the wire down, insert a 2 mm hexagonal key in the front of the contact and tighten to recommended torque.

- Usable conductor cross-sections (EN 60228 class 5):
 - from 2,5 mm² to 8 mm² (14 AWG to 10 AWG) (CX 02 4AF/M)
 - from 6 mm² to 10 mm² (10 AWG to 8 AWG) (CX 02 4BF/M)
 - (extra-flexible EN 60228 class 6: 2,5 mm² ... 6 mm² (14 AWG to 10 AWG))
- Use only stranded flexible copper conductors
- Do not twist the strands!
- Tightening torque with 2 mm hexagonal Allen key:
 - 1,5 Nm (13,3 lb.in) max for conductors with cross-section 2,5 mm² ... 4 mm² (14 AWG to 12 AWG)
 - 2 Nm (17,7 lb.in) max for conductors with cross-section 6 ... 10 mm² (10 AWG to 8 AWG)
- Stripping length: 8+1 mm



Enclosures assembly screws

In the table below, the recommended minimum and maximum tightening torque to apply to the fixing screws of ILME bulkhead mounting housings are shown, assuming the use of steel screws with 8.8 resistance class and a good fixing panel surface according to the requirements mentioned therein.

Series	Number of screws	Screw size	Recommended torque		Flange sealing element
			Nm	lb.in	
CK /MK, CKX, CKA /MKA, CQ	2	M3	0,8 – 1,0	7.1 – 8.9	Gasket
CK 03 IA4, MK AP /IAP with M25 cable entry	4	M3	0,6 – 0,7	5.3 – 6.2	Gasket
CKA 03 IA4, MKA AP /IAP with M25 cable entry	4	M3	0,8 – 1,0	7.1 – 8.9	Gasket
MIXO ONE	4	M3	0,5 – 0,9	4.4 - 8.0	Gasket
MIXO TWO (bulkhead mounting)	2	M4	0,8 – 1,2	7.1 – 10.6	Gasket
MIXO TWO (surface mounting)	4	M4	0,8 – 1,2	7.1 – 10.6	Gasket
CZI 15 /25	4	M3	0,8 – 1,0	7.1 – 8.9	Gasket
CHI 50	4	M4	1,2 – 1,8	10.6 – 15.9	Gasket
CHI 06 /10 /16 /24	4	M4	0,8 – 1,2	7.1 – 10.6	Gasket
CHI 32	4	M4	1,2 – 1,8	10.6 – 15.9	Gasket
CHI 48	4	M6	3,0 – 3,6	26.6 – 31.9	Gasket
CGK /MGK (IP68)	2	M4	0,8 – 1,2	7.1 – 10.6	O-ring
CGI /MGI 06 /10 /16 /24 (IP68)	2	M6	3,0 – 3,6	26.6 – 31.9	O-ring
T-TYPE, T-TYPE /H, T-TYPE /C, T-TYPE /W	4	M4	0,8 – 1,2	7.1 – 10.6	Gasket
BIG series hoods with integrated special self-centring floating frame	4	M5	2,0 – 2,5	17.7 – 22.1	–

To guarantee the declared IP degree of protection of the housings reported in this catalogue, according to EN IEC 60529 or to the relevant Type rating per ANSI/UL 50 and 50E (for those products bearing approval to those ratings), the surface of the mounting panel must meet the following requirements (definitions are provided in ISO 4287 standard):

- Waviness $W_t \leq 0,2$ mm over a distance of 200 mm (measured on the panel without load)
- Roughness $R_a \leq 16$ μ m

NOTE: The values of tightening torque indicated in the above table are just recommended values, that must be related – by the designer of the final application – to the resistance class of the screws (not included in the delivery), with the assumption that the mounting panel is sufficiently rigid (stiff). If the deflection of the panel, under the effect of tightening the screws, is greater than 0,7 mm over a distance of 100 mm, it is necessary to use the counter-flanges mentioned in our catalogue or the special flange gaskets available upon request (please contact our Sales Department). For the CGI /MGI IP68 enclosures the specific counter-flanges mentioned in our catalogue are always recommended.

Enclosures locking screws

Series	Number of screws	Screw size	Recommended tightening torque		Recommended size of screwdriver
			Nm	lb.in	
CGK /MGK	2	M4	1,2	10.6	1,0 × 5,5 or 7 mm hexagonal key
CG /MG	2	M6	2,5	22.1	1,6 × 10 or 10 mm hexagonal key

RANGE OF CONDUCTOR CROSS-SECTIONAL AREA AND STRIPPING LENGTH

Connector inserts	Range of conductor cross-sectional area		Stripping length
	Connection technology		
	Screw	mm ²	AWG
CK	0,75 – 2,5	18 – 14	6
CX 4/2, CX 4/8 (16A poles) ¹⁾	0,75 – 4	18 – 12	7
	0,75 – 2,5	18 – 14	7
CNE ¹⁾	0,5 – 4	20 – 12	7
CNE..X	0,25 – 2,5	24 – 14	7
CDA ¹⁾	0,5 – 4	20 – 12	7
CDA..X	0,25 – 2,5	24 – 14	7
CT 06..24	0,75 – 2,5	18 – 14	12
CT 40 and 64	0,75 – 2,5	18 – 14	12
CME ¹⁾	0,5 – 4	20 – 12	7
CME..X	0,5 – 2,5	20 – 14	7
CP ¹⁾	0,75 – 6	18 – 10	10,5
CX 4/.. (80A poles)	4 – 16	12 – 5	14
MIXO CX 01 YA /YPEA (for tubular cable lug)	10 – 70	6 – 2/0	³⁾
MIXO CX 01 30A /30PEA (for tubular cable lug)	10 – 120	6 – 4/0	³⁾
Crimp			
MIXO (5A), CX 25 IB	0,08 – 0,75	28 – 18	4
CQ 21	0,08 – 0,5	28 – 20	4
CDD, CD, MIXO (10 A), CQ 12, CQ 07	0,14 – 2,5*	26 – 14	8 / *6 for 2,5 mm ²
CCE, CDC, CMCE, CQ, CQE, CQEE, MIXO (16 A)	0,14 – 4	26 – 12	7,5
CX, MIXO (40 A), CQ4 03	1,5 – 2,5	16 – 14	9
	4 – 6	12 – 10	9,6
	10	8	15
CX 4/.., RX 4/.. (80 A) MIXO (70 A)	10 – 25	7 – 4	15
MIXO (100 A), CX 6/6	10 – 35	7 – 2	15
MIXO (200 A)	16 – 70	6 – 2/0	15
MIXO (300 A)	16 – 25	6 – 4	19
	35	2	20
	50 – 120	1 – 4/0	22,5
Spring			
CSE, CSH, CTSE 06..24, CMSH, MIXO [CX 05 S ²⁾ , CX 05 SH], CSS	0,14 – 2,5	26 – 14	9 – 11
MIXO CX 06 CY, CX 08 CY, CQY 05, CQY 08E CQEY 10..46 (AXYR [®])	0,25 – 4 un-ferruled 0,25 – 2,5 ferruled	22 – 12 un-ferruled 22 – 14 ferruled	9 – 11
CTS 40/64	0,14 – 2,5 un-ferruled 0,14 – 1 ferruled	26 – 14 un-ferruled 26 – 18 ferruled	9 – 11
CKS, CKSH, CDS, CDSH, CSAH, CDY 07 /08 (AXYR [®]), MIXO CX 12 DY (AXYR [®])	0,14 – 2,5 un-ferruled 0,14 – 1,5 ferruled	26 – 14 un-ferruled 26 – 16 ferruled	9 – 11

¹⁾ For CNE, CDA, CP, CME, "CX 4/8 – pole 16A" series connectors with screw terminal and conductor protection plate, the use of ferrules is not necessary (= un-ferruled conductor).

The use of ferrules (= ferruled conductor) causes a reduction in maximum useful cross-section to the lower size (e.g. 4 mm² un-ferruled - 2,5 mm² ferruled).

²⁾ Available upon request.

³⁾ Stripping length according to tubular cable lug specification.

LOAD CURVES

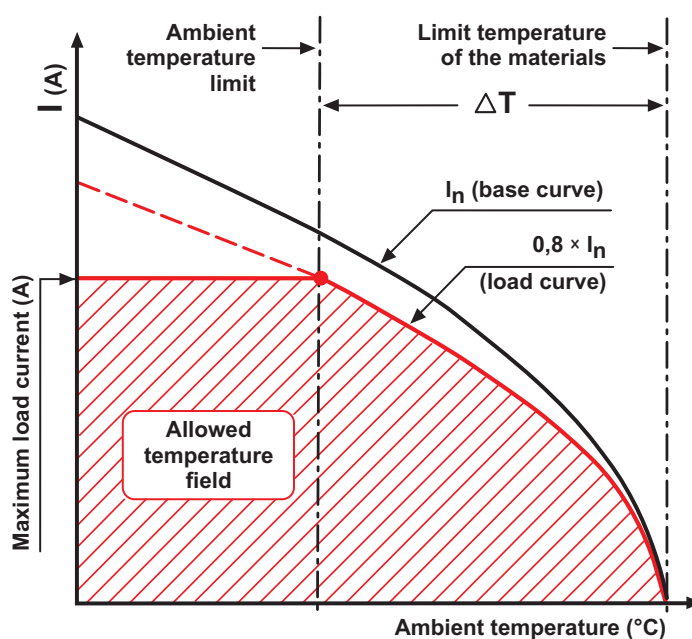
The permitted current-carrying capacity for connectors is variable: it decreases with the increase of the number of poles and of the ambient temperature in which the connector is installed and it depends upon the thermal properties of the material used for the contacts and the insulating parts, including that of the type of wiring used. The current-carrying capacity is obtained from the load curves which are constructed according to standard IEC 60512-5-2, for currents simultaneously circulating through all poles.

The limit current curves express current values of current that determine the achievement of the upper limiting temperature (ULT) of the materials. The choice of the permanent load applicable on the contacts **must be made within the possible field of operation possible delimited by the above-mentioned curves.**

Since use of connectors at the limit values of their characteristics is not recommended, the **base curve** is de-rated. The reduction of the load currents to 80% defines the correction curve, where both the maximum permissible contact resistances and the inaccuracy of the temperature measurements are sufficiently taken into consideration.

The correction curve represents the final **limit current curve (load curve)** as defined by standard IEC 60512-5-2. It therefore takes into consideration the differences between the various connector inserts, as well as errors in the temperature measurements.

All the load curves presented in this catalogue include the correction. See figure below.



Legend

Maximum load current (A)

Value for which the connector reaches the upper limit temperature of the material at the corresponding ambient temperature intersected on the load curve.

Limit temperature of the materials

Value determined by the characteristics of the material used. The sum of the ambient temperature and the increase of the ΔT (temperature rise) caused by the current flow shall not exceed the limit temperature of the materials.

Ambient temperature limit

The environmental conditions shall not exceed this value. It may be known and determines the maximum allowed load current, or it may be directly obtained from the load curve.

Base curve

Set of current and temperature values obtained from laboratory tests and influenced by the connector's characteristics (number of poles, constructional shape, thermal conductivity of the materials, etc.) and the cross-section of the conductor used.

Load curve (limit current curve)

Obtained from the base curve via the safety coefficient.

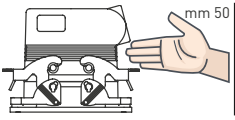
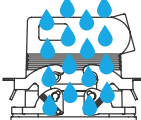
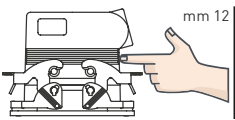
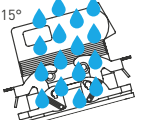
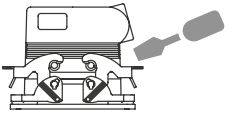
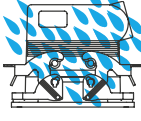
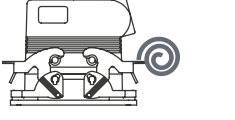
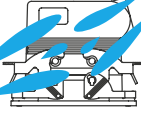
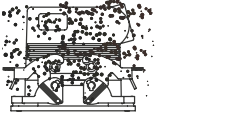
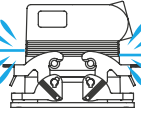
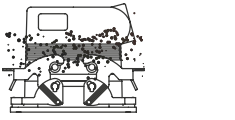
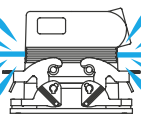
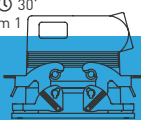
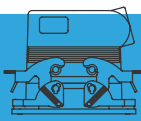

ΔT (temperature rise)

Temperature rise produced by a permanent current circulating through all the poles of a connector coupling; difference between the upper limiting temperature (ULT) of the material and the ambient temperature obtained on the limit current curve.

DEGREE OF PROTECTION

The connector's housing, sealing and locking mechanism protect the connection from external influences such as mechanical shocks, foreign bodies, humidity, dust, water or other fluids such as cleansing and cooling agents, oils, etc. The degree of protection the housing offers is explained in the IEC 60529, DIN EN 60529, standards that categorize enclosures according to foreign body and water protection.

In order to keep the declared degree of protection (IP code according to EN 60529, or Enclosure Type Rating according to ANSI/UL 50E), enclosures must be completed with cable glands and/or other accessories with at least an equal degree of protection.

FIRST Index figure	Degree of protection SOLIDS	SECOND Index figure	Degree of protection WATER
0	No protection	0	No protection
1	 Protected against access to hazardous parts with the back of a hand and protected against solid foreign objects of Ø 50 mm and greater	1	 Protected against vertically falling water drops
2	 Protected against access to hazardous parts with a finger - protected against solid foreign objects of Ø 12,5 mm and greater	2	 Protected against vertically falling water drops when enclosure tilted up to 15° (on either side of the vertical)
3	 Protected against access to hazardous parts with a tool - protected against solid foreign objects of Ø 2,5 mm and greater	3	 Protected against spraying water (at an angle up to 60° on either side of the vertical)
4	 Protected against access to hazardous parts with a wire - protected against solid foreign objects of Ø 1,0 mm and greater	4	 Protected against splashing water from any direction
5	 Protected against access to hazardous parts with a wire dust-protected (no harmful dust deposit)	5	 Protected against water jets from any direction
6	 Protected against access to hazardous parts with a wire dust-tight (total protection against dust)	6	 Protected against powerful water jets from any direction (similar to sea waves)
<p>RATING EXAMPLE</p> <p>IP 6 5</p>		7	 Protected against the effects of temporary immersion in water at a maximum depth of 1 metre for 30 min
		8	 Protected against the effects of continuous immersion in water at depth and/or duration upon agreement, more severe than for numeral 7
		9	 Protected against high pressure and temperature water jets from any direction

IP (Ingress Protection) Ratings Guide table

Description according to IEC 60529

CHANGEOVER FROM PG THREADS TO METRIC

After 31st December 1999, the German safety standard **DIN VDE 0619** (1987-09) and the standards it refers to – **DIN 46319** for dimensions with metric threads and **DIN 46320 (T1-T4)**, **DIN 46255** and **DIN 46259** for dimensions with Pg threads (Pg = Panzerrohr-Gewinde: literally “threads for armoured pipes”) – were withdrawn and European standard **EN 50262:1998** “Metric cable glands for electrical installations” has been in force since 1st January 2000. On 2016-09-23, **EN 62444:2013**, a modified version of IEC 62444:2010, finally replaced EN 50262 to cover with a broader scope, dimensions of metric cable glands with range M6 through M110, and as a guide even other type of entry threads of “Cable glands for electrical installations”.

The original **EN 50262:1998** standard defined new sizes with metric threads for cable glands according to **EN 60423** and established the safety prescriptions. However, it did not specify all cable glands’ dimensions: the span size of the tightening wrench, the diagonal dimension, or those of the sealings providing tightness to dust and liquids were left void of standardization, whereas the withdrawn DIN standards for Pg cable glands did cover any of such operational details. The standard came mandatorily into force on 1st April 2001, when the contrasting national standards were withdrawn.

EN 62444 is valid in all member countries of CENELEC (European Electrical Standardisation Committee) and its publication has led to a broadening of the supply of enclosures for multi-pole connectors for industrial use, to include new enclosure versions with cable entry suitable for metric cable glands.

In the meantime, **EN 61076-7-100:2006** “Connectors for electronic equipment – Product requirements – Part 7-100: Cable outlet accessories – Detail specification for a metric cable sealing consisting of an integrated part of heavy-duty rectangular or circular connector hoods and a sealing system” was published, providing dimensional requirements, application information and tests for metric cable sealing of heavy-duty rectangular or circular connector hoods (sized M12 × 1,5 through M50 × 1,5) to cover cable outlets comprising all the necessary parts designed to fulfil the specific degree of sealing of the hood that are not cable glands (i.e. that are not covered by EN 62444).

Cable gland producers have introduced the new metric series to add to the Pg size series, to gradually replace the latter type. The transitional period indicated in the new standard should have ended on 1st March 2001, after which date the use of cable entry devices with Pg thread and, as a result, enclosures with Pg thread, should have ended in new installations. Nevertheless, both the cable entry devices and the relevant enclosures with Pg thread, may continue to be used as spare parts. For the mandatory **CE** marking of these items, observance of the safety conditions specified by the Low Voltage Directive is sufficient, however adherence to the safety requirements of EN 62444 provides presumption of conformity.

 **To distinguish hoods and surface-mounting housings with metric entries from the relevant Pg versions (identified with a "C" pre-code), the ILME metric types are identified with an "M" pre-code. The transposition table below provides the correspondence rule adopted in most cases by ILME for creating the new metric versions.**

Pg → metric transposition table

Pg	Metric
Pg 11	M20
Pg 13.5	M20
Pg 16	M20
Pg 21	M25
Pg 29	M32
Pg 36	M40
Pg 42	M50
Pg 48	M63

Cable diameter for use with ILME cable glands

Series	Metric thread					
	20	25	32	40	50	63
AS M..P	6 - 12,5	10 - 18	14 - 24	15 - 24	23 - 30	26 - 35
AS M..E	8 - 12,5	13,5 - 18	17 - 24	—	—	—
AG M..T	6 - 8 - 10	11 - 14 - 17	19 - 21 - 24	26 - 29 - 32	35 - 38 - 41	—
AG M..I	5 - 12,5	9 - 18	14 - 25	18 - 32	24 - 38,5	—
AG M..R	6 - 8 - 10	11 - 14 - 17	19 - 21 - 24	—	—	—

For more information, please refer to the technical catalogue on www.ilme.com

T-TYPE ENCLOSURES

RESISTANCE TO CHEMICALS COMPARISON TABLE

The classification herewith provided is only a generic reference guide in order to enable a first selection. It is based on literature data provided by the suppliers of the raw materials used, which are related to tests carried out on specimens under test conditions which are not always homogeneous and involving accelerating techniques, therefore not necessarily describing real operational conditions. The actual behaviour of products in the field may therefore be positively or negatively

influenced by several variable environmental parameters such as temperature, relative humidity, simultaneous presence of a plurality of substances and their concentration, exposure time, dynamic or static application condition, and so on. The accuracy of transferring the indications given herein to the actual conditions of use is therefore merely indicative and does not imply any guarantee or responsibility by ILME.

	T-TYPE	T-TYPE/W	T-TYPE/H	T-TYPE/C
A				
Acetone (propanone)	x	x	x	x
Active chlorine	x	x	x	x
Alum	●	●	●	●
Ammonia, 10% aqueous solution	●	x	●	●
Ammonia, liquid	x	x	●	●
Ammonium acetate	●	x	●	●
Ammonium carbonate	●	●	●	x
Ammonium chloride	●	●	●	x
Ammonium nitrate	●	●	●	●
Ammonium phosphate	●	●	●	●
Ammonium sulphate	●	●	●	●
Amyl alcohol	□	□	□	x
Aniline	□	□	x	x
Aqua regia (1:3 nitric acid : hydrochloric acid)	x	x	x	x
Asphalt	□	□	□	x
B				
Beer	●	●	●	●
Benzene	x	□	x	x
Borax	□	□	□	□
Boric acid	●	●	●	●
Boric acid, 10% aqueous solution	●	●	●	●
Boric water (boric acid 3%)	●	●	●	●
Butane, gas	□	□	□	x
Butane, liquid	□	□	□	x
C				
Calcium chloride	●	●	●	●
Calcium chloride, 10% aqueous solution	●	●	●	●
Calcium chloride, diluted suspension	●	●	●	●
Calcium nitrate	●	●	●	●
Calcium sulphate	●	●	x	●
Caustic potash (potassium hydroxide) 10%	x	●	●	x
Citric acid 50% aqueous solution	x	x	●	●
Copper sulphate 10% aqueous solution	●	●	●	●
Cresol	□	□	x	x
Cresolic solution	□	□	x	x
Cutting oil	□	□	□	x
Cyclo-hexane	□	□	□	x
D				
Deca-hydro-naphtalene	x	x	x	x
Di-Ethylhexyl Phtalate	●	x	x	x
Di-isononyl Phtalate	●	x	x	x
Di-octyl Phtalate	●	●	x	x
Diesel Oil	□	□	□	□
Diluted Glucose	●	●	●	●

	T-TYPE	T-TYPE/W	T-TYPE/H	T-TYPE/C
D				
Diluted Glycerine	●	●	●	●
Diluted Glycol	●	●	●	●
Diluted Phenol	□	□	x	x
Diluted urea	●	●	●	●
E				
Ethanol (ethyl alcohol)	x	x	●	●
Ethyl alcohol, 10% aqueous solution	●	●	●	●
Ethylene-glycol or propylene-glycol	●	●	●	●
F				
Fatty acids	●	●	●	□
Ferric chloride, 10% aqueous solution	x	x	x	x
Formalin (formaldehyde 40% aqueous solution)	x	x	●	●
Fruit juices	●	●	●	●
Fuel oils	□	□	□	x
G				
Gaseous ammonia	□	x	●	●
Gaseous propane	x	●	●	x
Glycerine	●	●	●	●
Grinding oil	□	□	□	x
Gypsum (see calcium sulphate)	●	●	x	●
H				
Heptane	□	□	□	x
Hexane	□	□	□	x
Hydrochloric acid, <2% aqueous solution	x	x	●	□
Hydrogen sulphide	□	x	●	x
I				
Ink	●	●	●	●
IRM oil 901	●	●	●	●
IRM oil 902	□	●	●	x
IRM oil 903	x	□	□	□
Isopropyl alcohol	□	●	●	●
K				
Kitchen salt, aqueous solution	●	●	●	●
L				
Lactic acid	●	●	●	●
Linseed oil	●	●	●	●
Liquid soap	x	●	●	●
Lubricating engine oil	□	□	□	x
Lubricating oil	●	●	●	x

NOTE: As the characterizing element of the T-TYPE/W series is the different sealing gasket material, hoods and covers without sealing gaskets for this series are the same of T-TYPE Standard.

	T-TYPE	T-TYPE/W	T-TYPE/H	T-TYPE/C
M				
Mercury	●	●	●	●
Methanol (methyl alcohol)	x	x	●	●
Methyl alcohol, diluted 50%	□	□	●	●
Mineral based oil	●	●	●	●
Mineral oils (un-tasteful)	●	●	●	●
Mothballs (naphthalene, paradichlorobenzene)	□	□	x	x
Muriatic acid, concentrated	x	x	x	x

N				
n-Butanol (butyl alcohol)	●	●	●	●
Naphthalene	□	●	x	x
Normal (low octane) gasoline (petrol)	□	□	□	x

O				
Octane	□	□	□	x
Oleic acid	●	●	●	x
Oxalic acid	●	●	●	●
Ozone	x	x	x	□

P				
Paraffin oil	●	●	●	●
Petrol ether	□	□	□	□
Petroleum	●	●	●	●
Petroleum spirit (dry cleaning)	□	□	x	x
Potassium carbonate	●	●	●	●
Potassium chlorate	●	●	x	●
Potassium chloride	●	●	●	●
Potassium cyanide, aqueous solution	●	●	●	●
Potassium di-chromate	□	□	●	●
Potassium iodide	□	□	●	●
Potassium nitrate	□	x	x	●
Potassium persulphate	□	□	x	●
Potassium sulphate	□	□	●	●

S				
Sea water	●	●	●	●
Silicon oil	●	●	●	x
Soap solution	□	●	●	●
Sodium bicarbonate (oxide)	●	●	●	●
Sodium carbonate (washing soda)	●	●	●	●
Sodium chlorate	●	●	x	●
Sodium chloride (kitchen salt)	●	●	●	●
Sodium bisulphate, aqueous solution	●	●	●	●
Sodium hydroxide (caustic soda)	x	x	●	●
Sodium hydroxide 12,5% (liscivia)	□	x	●	●
Sodium Hypochlorite	x	x	●	●

	T-TYPE	T-TYPE/W	T-TYPE/H	T-TYPE/C
S				
Sodium nitrate	●	●	●	x
Sodium nitrite	□	□	●	x
Sodium perborate	●	●	●	●
Sodium phosphate	●	●	●	x
Sodium silicate	●	x	x	●
Sodium sulphate	●	●	●	●
Sodium sulphide	●	●	●	●
Sodium Thiosulphate (photographic fixer)	●	●	●	●
Solution for photographic processing	●	●	●	●
Starch, aqueous (amylum)	●	●	●	●
Stearic acid	●	●	●	●
Succinic acid (butanedioic acid)	●	●	●	●
Sulphur	●	●	x	x
Sulphur dioxide (sulphurous anhydride)	□	x	x	□
Sulphuric acid, 2% aqueous solution	x	x	□	□

T				
Tallow	●	●	●	●
Tar	□	□	x	□
Tartaric acid	●	●	●	●
Toluene	x	x	x	x
Transformer oil (dielectric)	●	●	●	●
Trichloroethylene	x	x	x	x
Tricresyl phosphate	●	●	x	x
Turpentine essence	x	□	□	x

U				
Urine	●	●	●	●

V				
Vegetable oil	●	●	●	●
Vinegar	x	□	●	□

W				
Water	●	●	●	●
White alcohol (isopropanol + ethanol)	□	●	●	●

X				
Xylene	x	x		

Legend

● : Resistant □ : Limited resistance x : Not resistant

DIMENSIONING OF CLEARANCES – CREEPAGE DISTANCES

European standard EN 61984:2009 which incorporates without modification the corresponding international standard IEC 61984 Ed. 2.0 (2008-10) is the reference standard for safety requirements and the relevant tests for multipole connectors for industrial uses.

It is applicable to connectors with rated voltage values of over 50 V, and up to 1.000 V, and rated currents values of up to 125 A per pole, for which no dedicated standard exists, or to which the detail specifications or the manufacturer refer in regard to safety aspects. It can be used as a guide for connectors with rated current exceeding 125 A per pole and for those with a rated voltage above 50 V (the latter excluded from the scope of the Low Voltage Directive 2014/35/EU).

The last edition of the EN 61984 standard also introduced the definition of **connector without breaking capacity (COC)** to better distinguish this category of products from **connectors with breaking capacity (CBC)**.

For the safety and performance requirements of connector terminals, which depend on the connection technology adopted, this standard integrally refers to the corresponding standards (EN IEC 60999 series for screw-type and screwless type terminals, EN IEC 60352 series for solderless connections and relevant terminations).

For determining the minimum clearances and creepage distances (i.e. distances through-air and along the insulating surface) for connectors, this standard now refers, without any modifications, to standard IEC 60664-1 Ed. 2.0 (2007-04)¹⁾. In the following, the method for determining the minimum insulation in connectors is illustrated with reference to the IEC 60664-1 standard. The rated characteristics of each ILME connector family are provided on pages INTRO.22-31. As already in the first edition, the following are now obsolete: the insulation group concept and the distinction of rated voltage values into DC and AC, voltage values 220 V and 380 V were adapted to standardised values 230 V and 400 V according to IEC 60038²⁾ and some concepts were taken from the regulations for LV electrical systems of the IEC 60364³⁾ series, such as:

- a. the **overvoltage category** (I, II, III, IV), according to the use of the equipment⁴⁾: this is correlated with the transient overvoltages taken as a basis for determining the rated impulse voltage;
- b. the **pollution degree** (1, 2, 3);
- c. the **material group** (I, II, III) classification of insulating materials according to their resistance to tracking;
- d. the **electric field condition** (*homogenous or inhomogeneous*).

a. Overvoltage categories (or impulse withstand category)

The overvoltage category of a circuit or of an electrical system is identified by a conventional numeral (from I to IV) based on the limitation or the control of the assumed transient overvoltage values obtained on a circuit or electrical system and depends on the means used to reduce the overvoltages.

Table F.1 provides the rated impulse voltage for equipment energised directly from the low voltage mains as a function of the rated voltage of the power supply system, of the relevant line-to-neutral voltage and of the overvoltage category.

- 1) Endorsed with modifications as European standard EN 60664-1:2007 and published by CENELEC member countries as a national standard: Italian standard CEI EN 60664-1:2008-04 (CEI 109-1), German standard DIN EN 60664-1:2008-01 (VDE 0110-1). Being a dated reference in EN 61984:2009, this is still the edition of reference, however, the latest edition Ed.3.0 is IEC 60664-1:2020-05 + IEC 60664-1/COR1:2020-10, harmonized in EU as EN IEC 60664-1:2020-07 + EN IEC 60664-1/AC:2020-12.
- 2) EN 60038:2011 (IEC 60038-2009, modified), Italian standard CEI EN 60038:2012-08 (CEI 8-6), German standard DIN EN 60038:2012-04 (VDE 0175-1).
- 3) Italian standard CEI 64-8, German standard DIN VDE 0100.
- 4) EN 60664-1 clarifies that the term "overvoltage category" is synonymous with "impulse withstand category" used in Clause 443 of IEC 60364-4-44.

TABLE F.1.
Rated impulse voltage for equipment powered directly from the low-voltage mains (IEC 60664-1 Ed. 2.0 2008-10)

Nominal voltage according to IEC 60038 (CENELEC HD 472 S1, CEI 8-6)		Voltage line to neutral derived from nominal voltages a.c. or d.c.	Rated impulse voltage ^{b)} Overvoltage category			
V Three-phase ^{a)}	V Single phase		≤ V	V		
			I	II	III	IV
		50	330	500	800	1 500
		100	500	800	1 500	2 500
	120-240	150	800	1 500	2 500	4 000
230/400 277/480		300	1 500	2 500	4 000	6 000
400/690		600	2 500	4 000	6 000	8 000
1 000		1 000	4 000	6 000	8 000	12 000

- a) The "I" symbol indicates a four-wire three phase distribution system (star distribution). The lower value is the voltage between phase and neutral (phase voltage), whereas the higher value is the voltage between the phases (mains voltage). Where only one value is indicated, it refers to three-wire, three-phase systems (delta distribution) and specifies the line-to-line value.
- b) Equipment with these rated impulse values can be used in installations in accordance with standard IEC 60364-4-443 (Italian standard CEI 64-8/4 Section 443, German DIN VDE 0100-443).

Industrial machinery and installations with fixed connection to the low voltage supply system, hence their relevant components including multipole connectors, constitute an example of equipment belonging to overvoltage category III.

Examples of general equipment that comes under overvoltage category II are household electrical appliances, portable tools and other household or similar equipment.

For distribution networks with rated voltage **230/400 V** (star distribution, neutral-earthed) and overvoltage category III (impulse withstand category III), the required rated impulse withstand voltage is **4 kV**.

For distribution networks with rated voltage **400 V** or **500 V** (star distribution without neutral or with unearthed neutral, or delta distribution unearthed or corner-earthed) and overvoltage category III (impulse withstand category III), the required rated impulse withstand voltage is **6 kV**.

b. Pollution degree

Pollution indicates the presence of any kind of foreign matter, whether solid, liquid or gaseous (ionised gas) that can result in a reduction of dielectric strength or surface resistivity of the insulation. The standard establishes four pollution degrees. The categories are identified by conventional numerals based on the quantity of polluting agents or on the frequency of the phenomenon which determines the reduction of the dielectric strength and/or of the surface resistivity.

Pollution degree 1

No pollution or only dry, non-conductive pollution. The pollution has no influence.

Pollution degree 2

Only non-conductive pollution occurs except that occasionally a temporary conductivity caused by condensation is to be expected.

Pollution degree 3

Conductive pollution occurs or dry non-conductive pollution occurs which becomes conductive due to condensation which is to be expected.

Pollution degree 4

Continuous conductivity occurs due to conductive dust, rain or other wet conditions.

Pollution degree 3 is typical of an industrial environment or similar, while pollution degree 2 is typical of a household or similar environment.

EN 61984 allows the dimensioning of creepage distances (insulating distances along the surfaces) of connectors installed in enclosures with degree of protection \geq IP54 for the pollution degree immediately below that of the application environment (e.g.: 2 instead of 3).

Abstract from EN 61984

6.19.2.1 For a connector with a degree of protection IP54 or higher according to IEC 60529, the insulating parts inside the enclosure may be dimensioned for a lower pollution degree.

This lower pollution degree also applies to mated connectors where the enclosure is ensured by the connector housing and which may only be disengaged for test and maintenance purposes.

One may therefore use connectors installed in housings or enclosures with a degree of protection \geq IP54, at the rated voltage suitable to pollution degree 2 in industrial applications with pollution degree 3, if, in compliance with EN 61984, the connector coupling is opened only occasionally for test and maintenance purposes. Even in the event of temporary or limited permanence in uncoupled state, a closing cover is recommended in order to guarantee at least the IP54 degree of protection.

However, this does not apply to connectors which remain uncoupled and exposed to an industrial atmosphere for an indefinite period.

It should also be noted that pollution might penetrate inside coupled connectors also from remote parts of the electrical system, e.g. through conduits providing cable entry to the connectors enclosure.

Moreover, connector enclosures are usually supplied without cable entry devices, to let the installer select the most suitable one for its end-use application. The IP degree of protection – or the Type rating according to North American standards – marked or assigned to the connector enclosures is guaranteed only for mated and locked connectors that employ cable entry devices with IP degree and/or Type rating equal or higher than those of the connector enclosures chosen, installed in a workmanlike manner.

Examples of application for the selection of pollution degree 2 for a connector:

- Connector on an electric motor controller, which is uncoupled only to replace a faulty motor, also in cases where pollution degree 3 is instead specified for the system.
- Connector on a machine built in modules, which is opened only for transport purposes and which is used only for faster installation and for safer putting into service. One must make sure that the connector has not been polluted during transport. To ensure this has not occurred, protective covers or adequate packing must be used.
- Connector inside a panel with degree of protection \geq IP54. In this case one may even avoid equipping the connector with an IP54 enclosure.

c. Material group

The insulating material influences the determination of the minimum creepage distance. It is characterised according to the damage it suffers from the concentrated release of energy during scintillations when a surface leakage current is interrupted due to the drying of the contaminated surface.

The **CTI** (comparative tracking index, index of resistance to surface currents, defined in EN IEC 60112) is assumed as index of the resistance to creep currents of the insulating materials in the presence of atmospheric contaminating agents.

The CTI constitutes the numerical value of the maximum voltage at which a material can resist against 50 drops of an electrolytic test solution without tracking failure, i.e. without failure of insulation due to a progressive formation of conductive paths on the surface and/or within the solid insulating material (causing permanent electric arc between the electrodes of the test equipment) due to the combined effect of electric stress and electrolytic contamination.

Solid insulating materials are classified into four groups:

group I	600 \leq CTI
group II	400 \leq CTI < 600
group IIIa	175 \leq CTI < 400
group IIIb	100 \leq CTI < 175

For the purpose of determining the minimum creepage distances, the values for groups IIIa / IIIb (Table F.2, IEC 60664-1) are identical.

The insulating materials used to manufacture the ILME multipole connectors belong to groups IIIa / IIIb.

d. Electric field conditions

Minimum clearance (shortest distance in air between two conductive parts) is determined by Table F.2 of IEC 60664-1, bearing in mind the following influencing factors:

- the rated impulse voltage;
- the electric field condition;
- the altitude: the values specified in Table 2 are valid up to 2 000 m; for higher altitudes, the corrective factors specified in Table F.8 of IEC 60664-1 shall be used;
- the micro-environment.

The shape and arrangement of the conductive parts influence homogeneity of the electric field, hence the clearance able to insulate live parts. Clearances of **case A (inhomogeneous field)** withstand the corresponding impulse voltage under all conditions: clearances not less than those specified in **Table F.2 – case A** can be used irrespective of the shape and arrangement of the conductive parts and without verification by an impulse test.

1. Determination of clearances

To determine minimum clearance, the following must be identified in accordance with IEC 60664-1 standard:

- a) the rated voltage of the power supply (usually 230/400 V thus a conventional voltage line-to-neutral of 300 V, in star distribution networks with earthed neutral, or 400 V for star networks without neutral, or with unearthed neutral, or in networks with secondary windings of the distribution transformer delta connected, unearthed or corner-earthed and, therefore, with conventional line voltage 600 V);
- b) the overvoltage category (usually III).
- c) The rated impulse voltage determined from Table B.2 of IEC 60664-1 (usually 4 kV or 6 kV).
- d) The electric field condition to which the parts through which the current flows shall be subjected (worst case = inhomogeneous field) and the pollution degree (usually 3).

EN 61984 requires that the **clearance** be dimensioned according to IEC 60664-1. For clearances up to 2 mm, typically for printed circuit board connectors, the reference standard may alternatively be IEC 60664-5, to be read in conjunction with IEC 60664-1. The minimum clearance (shortest distance in air between two conductive parts) is therefore given by **Table F.2** of IEC 60664-1, according to the rated impulse voltage derived from **Table B.2** of the same standard, which is part of **Annex B** (informative) **Nominal voltages of supply systems for different modes of overvoltage control**. This table is attributable in particular to devices that do not foresee upstream any overvoltage surge arrester; it represents, therefore the "worst case" and replaces **Table 5** of the previous edition of EN 61984. The rated impulse voltage must be chosen based on the nominal supply voltage and the overvoltage category. The assignment of connectors to a particular overvoltage category (usually III) is performed according to the rules of IEC 60664-1.

Here below three important definitions from EN 61984 to consider regarding "voltage":

rated voltage

value of voltage assigned by the manufacturer to the connector and to which the operating and performance characteristics are referred

NOTE - A connector may have more than one rated voltage value.

[IEC 60664-1:2007, definition 3.9, modified].

rated impulse voltage

impulse withstand voltage assigned by the manufacturer to the connector, characterizing the specified withstand capability of its insulation against transient overvoltages

[IEC 60664-1:2007, 3.9.2, modified].

impulse withstand voltage

highest peak value of impulse voltage of prescribed form and polarity which does not cause insulation breakdown of insulation under specified conditions

NOTE - The impulse withstand voltage is equal to or higher than the rated impulse voltage

[IEC 60664-1:2007, 3.8.1, modified].

In regard to the choice of the electric field condition, the clearances through possible windows and openings in the insulating material housings, shall comply with the values of Case A of Table F.2 of IEC 60664-1, i.e. for inhomogeneous field conditions.

TABLE B.2
Inherent control or control of equivalent protection [IEC 60664-1 Ed.2.0 (2007-04)].

Voltage line-to-neutral derived from nominal voltages a.c. or d.c. up to and including ¹⁾	Nominal voltages presently used in the world				Rated impulse voltage for the device ¹⁾ V			
	Three-phase four-wire systems with earthed neutral	Three-phase three-wire systems earthed or unearthed	Single-phase two-wire systems a.c. or d.c.	Single-phase three-wire systems a.c. or d.c.				
					Overvoltage category			
V	V	V	V	V	I	II	III	IV
50			12,5 24 25 30 42 48	30-60	330	500	800	1 500
100	66/115	60	60		500	800	1 500	2 500
150	120/208 ²⁾ 127/220	115, 120, 127	100 ³⁾ , 110, 120	100/ 200 ²⁾ 110-220 120-240	800	1 500	2 500	4 000
300	220/380, 230/400, 240/415, 260/440, 277/480	200 ³⁾ , 220, 230, 240, 260, 277	220	220-440	1 500	2 500	4 000	6 000
600	347/600 380/660 400/690 417/720 480/830	347, 380, 400, 415, 440, 480, 500, 577, 600	480	480-960	2 500	4 000	6 000	8 000
1 000		660 690, 720 830/1000	1 000		4 000	6 000	8 000	12 000

1) These columns are taken from Table F.1 indicating the rated impulse withstand voltages.

2) Used in the United States and Canada.

3) Used in Japan

With the three values (b) (c) and (d) the minimum clearance is determined in Table F.2 IEC 60664-1

TABLE F.2
Clearances to withstand transient overvoltages [IEC 60664-1
Ed. 2.0 (2007-04)].

Required impulse withstand voltage 1) 5)	Minimum clearances in air up to 2.000 m. above sea level					
	Case A Inhomogeneous field (see 3.15) Pollution degree 6)			Case B Homogeneous field (see 3.14) Pollution degree 6)		
	1	2	3	1	2	3
kV	mm	mm	mm	mm	mm	mm
0,33 2)	0,01	0,2 3) 4)	0,8 4)	0,01	0,2 3) 4)	0,8 4)
0,4	0,02			0,02		
0,50 2)	0,04			0,04		
0,6	0,06			0,06		
0,80 2)	0,1			0,1		
1	0,15			0,15		
1,2	0,25	0,25	0,2	0,3	0,3	
1,5 2)	0,5	0,5	0,3	0,3		
2	1	1	1	0,45	0,45	
2,5 2)	1,5	1,5	1,5	0,6	0,6	
3	2	2	2	0,8	0,8	
4,0 2)	3	3	3	1,2	1,2	1,2
5	4	4	4	1,5	1,5	1,5
6,0 2)	5,5	5,5	5,5	2	2	2
8,0 2)	8	8	8	3	3	3
10	11	11	11	3,5	3,5	3,5
12 2)	14	14	14	4,5	4,5	4,5
15	18	18	18	5,5	5,5	5,5
20	25	25	25	8	8	8
25	33	33	33	10	10	10
30	40	40	40	12,5	12,5	12,5
40	60	60	60	17	17	17
50	75	75	75	22	22	22
60	90	90	90	27	27	27
80	130	130	130	35	35	35
100	170	170	170	45	45	45

- 1) This voltage is
- for functional insulation, the maximum impulse voltage expected to occur across the clearance (see 5.1.5);
- for basic insulation directly exposed or significantly influenced by transient overvoltages from the low-voltage mains (see 4.3.3.3, 4.3.3.4.1 and 5.1.6), the rated impulse voltage of the equipment;
- for other basic insulations (see 4.3.3.4.2), the highest impulse voltage that can occur in the circuit.

For reinforced insulation see 5.1.6.

- 2) Preferred values as specified in 4.2.3.
3) For printed wiring material, the values for pollution degree 1 apply except that the value shall not be less than 0,04 mm, as specified in Table F.4.
4) The minimum clearances given for pollution degrees 2 and 3 are based on the reduced withstand characteristics of the associated creepage distance under humidity conditions (see IEC 60664-5).
5) For parts or circuits within equipment subjected to impulse voltages according to 4.3.3.4.2, interpolation of values is allowed. However, standardization is achieved by using the preferred series of impulse voltage values in 4.2.3.
6) The dimensions for pollution degree 4 are as specified for pollution degree 3, except that the minimum clearance is 1,6 mm.

When the clearance is less than the value indicated for case A, an impulse voltage test is required.

Compared to the previous edition of IEC 60664-1, Table F.2 has been modified. In particular: the columns referring to pollution degree 4 have been removed, the definition of this pollution degree has been modified in 4.6.2 to: "continuous conductivity occurs due to conductive dust, rain or other wet conditions"; and clearances for pollution degree 4 area as specified for degree of pollution 3, with the exception that the minimum clearance is 1,6 mm.

In 4.6.3 it states: "The dimensions for creepage distance cannot be specified where permanently conductive pollution is present (pollution degree 4). For temporarily conductive pollution (pollution degree 3), the surface of the insulation may be designed to avoid a continuous path of conductive pollution, e.g. by means of ribs and grooves (see 5.2.2.5 and 5.2.5)".

The values in bold are the most common in multipole connectors for industrial purposes.

If the component fulfils the minimum clearance prescribed for live parts at opposed polarities, it is exempted from the impulse withstand test. This test is run at sea level using increased voltage values in order to take into account rarefied air at high altitude (the prescribed values refer to 2 000 m a.s.l.). However, if this minimum clearance is not fulfilled, passing the test gives one the right to declare the relevant rated impulse voltage. Declaration of the rated impulse voltage is optional according to EN 61984: if the manufacturer declares the rated impulse voltage, the impulse withstand test is necessary as dielectric verification.

Alternatively, a dielectric voltage withstand test at mains frequencies of 50/60 Hz for 60 s (test 4a of IEC 60512) is necessary, but at reduced values compared to the peak values of the impulse test voltages of wave shape standardised at 1,2/50 µs.

For this purpose, standard EN 61984 provides the following cross-reference table:

TABLE 8
Test voltages (EN 61984 Ed. 2.0 - 2009-06)

Rated impulse withstand voltage U_{imp} kV	Test voltages		
	Impulse withstand voltage * kV (1,2/50 µs)		Withstand voltage (r.m.s. value) kV (50/60 Hz)
	at 2000 above sea level	at sea level	
0,5	0,5	0,55	0,37
0,8	0,8	0,91	0,5
1,5	1,5	1,75	0,84
2,5	2,5	2,95	1,39
4	4	4,8	2,21
6	6	7,3	3,31
8	8	9,8	4,26
12	12	14,8	6,6

* If the test laboratory is situated between sea level and an altitude of 2 000 m a.s.l., interpolation of impulse withstand voltage is allowed.

NOTE - This table uses the characteristics of an inhomogeneous field, case A of IEC 60664-1 (worst case).

2. Determination of minimum creepage distance

For the **minimum creepage distance** (*shortest distance along the surface of a solid insulating material between two conductive parts*, IEC 60664-1 definition 3.3) IEC 61984 refers to what prescribed by IEC 60664-1 in **Table F.4**. It is determined according to: rated voltage, pollution degree and insulating material group.

The rated voltage providing access to **Table F.4** (rationalised voltage derived from the nominal voltages at which the connector is deemed to operate) is determined by **Table F.3a** of IEC 60664-1 for single-phase two or three-wire AC or DC systems or **Table F.3b** for three-phase three or four-wire AC systems.

TABLE F.3a
Single-phase two or three-wire AC or DC systems
(IEC 60664-1 Ed. 2.0 - 2007-04).

Rated supply voltage ³⁾	Rationalised voltages for Table F.4	
	For insulation phase-phase ¹⁾	For insulation phase-phase ¹⁾
	All systems	Three-wire systems with intermediate earth point
V	V	V
12,5	12,5	-
24	25	-
25	25	-
30	32	-
42	50	-
48	50	-
50 ⁴⁾	50	-
60	63	-
30-60	63	32
100 ⁴⁾	100	-
110	125	-
120	125	-
150 ⁴⁾	160	-
220	250	-
110-220	250	125
120-240	250	125
300 ⁴⁾	320	-
220-440	500	250
600 ⁴⁾	630	-
480-960	1000	500
1000 ⁴⁾	1000	-

- 1) The line-to-earth insulation level for unearthed or impedance-earthed lines is equal to that between lines (phases), because the operating voltage of any line (phase) can, in practice, approach full voltage between lines (phases) [line voltage]. This is because the actual voltage to earth is determined by the insulation resistance and by the capacitive reactance of each line-to-earth. Consequently, a low (but acceptable) insulation resistance of a line can, in effect, earth it and increase voltage to earth of the other two phases at full voltage between the lines [line voltage].
- 2) For equipment for use on both three-phase three-wire and three-phase four-wire AC systems, earthed or unearthed, use only the values for three-wire systems.
- 3) It is assumed that the rated voltage of the equipment is not less than this value.
- 4) These values correspond to the values given in Table F.1.

Usually for three-phase systems with 230/400 V nominal voltage, the conventional line-to-line insulation voltage is 400 V and the line-to-earth for TT or TN systems is 250 V.

For three-phase systems with 400 V or 500 V nominal voltage, the conventional line-to-line insulation voltage is respectively 400 V and 500 V.

The pollution degree must be specified according to IEC 60664-1.

This strongly influences the **rated insulation voltage** of a connector. Therefore, the rated insulation voltage of a connector should be reconsidered time by time for each pollution degree.

TABLE F.3b
Three-phase four or three-wire AC systems
(IEC 60664-1 Ed. 2.0 - 2007-04).

Rated supply voltage ³⁾	Rationalised voltages for Table F.4		
	For insulation phase-phase ¹⁾	For insulation phase-phase ¹⁾	
	All systems	Four-wire three-phase systems with earthed neutral	Four-wire three-phase systems unearthed ¹⁾ or with earthed phase
V	V	V	V
63	63	32	63
110	125	80	125
120	125	80	125
127	125	80	125
150 ⁴⁾	160	-	160
208	200	125	200
220	250	160	250
230	250	160	250
240	250	160	250
300 ⁴⁾	320	-	320
380	400	250	400
400	400	250	400
415	400	250	400
440	500	250	500
480	500	320	500
500	500	320	500
575	630	400	630
600 ⁴⁾	630	-	630
660	630	400	630
690	630	400	630
720	800	500	800
830	800	500	800
960	1000	630	1000
1000 ⁴⁾	1000	-	1000

With this rationalized voltage value, the pollution degree and the material group the minimum creepage distance can be determined using **Table F.4**.

TABLE F.4
Creepage distances to avoid failure due to tracking
[IEC 60664-1 Ed.2.0 (2007-04)].

Effective voltage ¹⁾	Minimum creepage distances								
	Materials for printed circuits		Pollution degree						
			1			2			3
	All material groups	All material groups except IIIb	All material groups	Material group I	Material group II	Material group III	Material group I	Material group II	Material group III ²⁾
V	mm	mm	mm	mm	mm	mm	mm	mm	mm
10	0,0250	0,040	0,080	0,400	0,400	0,400	1,000	1,000	1,000
12.5	0,0250	0,040	0,090	0,420	0,420	0,420	1,050	1,050	1,050
16	0,0250	0,040	0,100	0,450	0,450	0,450	1,100	1,100	1,100
20	0,0250	0,040	0,110	0,480	0,480	0,480	1,200	1,200	1,200
25	0,0250	0,040	0,125	0,500	0,500	0,500	1,250	1,250	1,250
32	0,0250	0,040	0,14	0,53	0,53	0,53	1,30	1,30	1,30
40	0,0250	0,040	0,16	0,56	0,80	1,10	1,40	1,60	1,80
50	0,0250	0,040	0,18	0,60	0,85	1,20	1,50	1,70	1,90
63	0,0400	0,063	0,20	0,63	0,90	1,25	1,60	1,80	2,00
80	0,0630	0,100	0,22	0,67	0,95	1,30	1,70	1,90	2,10
100	0,1000	0,160	0,25	0,71	1,00	1,40	1,80	2,00	2,20
125	0,1600	0,250	0,28	0,75	1,05	1,50	1,90	2,10	2,40
160	0,2500	0,400	0,32	0,80	1,10	1,60	2,00	2,20	2,50
200	0,4000	0,630	0,42	1,00	1,40	2,00	2,50	2,80	3,20
250	0,5600	1,000	0,56	1,25	1,80	2,50	3,20	3,60	4,00
320	0,75	1,6	0,75	1,60	2,20	3,20	4,00	4,50	5,00
400	1,0	2,0	1,0	2,0	2,8	4,0	5,0	5,6	6,3
500	1,3	2,5	1,3	2,5	3,6	5,0	6,3	7,1	8,0 (7,9) ⁴⁾
630	1,8	3,2	1,8	3,2	4,5	6,3	8,0 (7,9) ⁴⁾	9,0 (8,4) ⁴⁾	10,0 (9,0) ⁴⁾
800	2,4	4,0	2,4	4,0	5,6	8,0	10,0 (9,0) ⁴⁾	11,0 (9,6) ⁴⁾	12,5 (10,2) ⁴⁾
1.000	3,2	5,0	3,2	5,0	7,1	10,0	12,5 (10,2) ⁴⁾	14,0 (11,2) ⁴⁾	16,0 (12,8) ⁴⁾
1.250			4,2	6,3	9,0	12,5	16,0 (12,8) ⁴⁾	18,0 (14,4) ⁴⁾	20,0 (16,0) ⁴⁾
1.600			5,6	8,0	11,0	16,0	20,0 (16,0) ⁴⁾	22,0 (17,6) ⁴⁾	25,0 (20,0) ⁴⁾
2.000			7,5	10,0	14,0	20,0	25,0 (20,0) ⁴⁾	28,0 (22,4) ⁴⁾	32,0 (25,6) ⁴⁾
2.500			10,0	12,5	18,0	25,0	32,0 (25,6) ⁴⁾	36,0 (28,8) ⁴⁾	40,0 (32,0) ⁴⁾
3.200			12,5	16,0	22,0	32,0	40,0 (32,0) ⁴⁾	45,0 (36,0) ⁴⁾	50,0 (40,0) ⁴⁾
4.000			16,0	20,0	28,0	40,0	50,0 (40,0) ⁴⁾	56,0 (44,8) ⁴⁾	63,0 (50,4) ⁴⁾
5.000			20,0	25,0	36,0	50,0	63,0 (50,4) ⁴⁾	90,0 (56,8) ⁴⁾	100,0 (64,0) ⁴⁾
6.300			25,0	32,0	45,0	63,0	80,0 (64,0) ⁴⁾	110,0 (72,0) ⁴⁾	125,0 (80,0) ⁴⁾
8.000			32,0	40,0	56,0	80,0	100,0 (80,0) ⁴⁾	140,0 (88,0) ⁴⁾	160,0 (100,0) ⁴⁾
10.000			40,0	50,0	71,0	100,0	125,0 (100,0) ⁴⁾	140,0 (112,0) ⁴⁾	160,0 (128,0) ⁴⁾
12.500			50,0 ³⁾	63,0 ³⁾	90,0 ³⁾	125,0 ³⁾			
16.000			63,0 ³⁾	80,0 ³⁾	110,0 ³⁾	160,0 ³⁾			
20.000			80,0 ³⁾	10,0 ³⁾	140,0 ³⁾	200,0 ³⁾			
25.000			10,0 ³⁾	125,0 ³⁾	180,0 ³⁾	250,0 ³⁾			
32.000			125,0 ³⁾	160,0 ³⁾	220,0 ³⁾	320,0 ³⁾			
40.000			160,0 ³⁾	200,0 ³⁾	280,0 ³⁾	400,0 ³⁾			
50.000			200,0 ³⁾	250,0 ³⁾	360,0 ³⁾	500,0 ³⁾			
63.000			250,0 ³⁾	320,0 ³⁾	450,0 ³⁾	600,0 ³⁾			

1) This voltage is

- for functional insulation, the working voltage;
- for basic and supplementary insulation of the circuit energized directly from the supply mains (see 4.3.2.2.1), the voltage rationalized through Table F.3a or Table F.3b, based on the rated voltage of the equipment, or the rated insulation voltage;
- for basic and supplementary insulation of systems, equipment and internal circuits not energized directly from the mains (see 4.3.2.2.2), the highest r.m.s. voltage which can occur in the system, equipment or internal circuit when supplied at rated voltage and under the most onerous combination of conditions of operation within equipment rating.

2) Material group IIIb is not recommended for application in pollution degree 3 above 630 V.

3) Provisional data based on extrapolation. Technical committees who have other information based on experience may use their dimensions.

4) The values given in brackets may be applied to reduce the creepage distance in case of using a rib (see 5.2.5).

NOTE - The high precision used in indicating creepage distances in this table does not mean that the uncertainty of measurement has to be of the same order of magnitude.

In **boldface** the typical values for multipole rectangular connectors for industrial uses are shown.

EU ENVIRONMENTAL LEGISLATION

RoHS 2 (2011/65/EU) and WEEE 2 (2012/19/EU) Directives

The **RoHS 2 2011/65/EU Directive** (recast) replaced on 2013-01-03 the original RoHS 2002/95/EC Directive (with its later amendment 2008/35/EC).

This Directive introduced the ban of use of certain hazardous substances in new electrical and electronic equipment (end products) placed on the market from 1st of July 2006 (the exceptions for some applications were listed in Annex of the Directive and in a number of further Decisions of the EU Commission). Indirectly – in the supply chain – the ban also applied to the electrical components of said electrical and electronic equipment.

The banned and/or restricted substances originally were:

Lead (Pb) (0,1 %), **Mercury (Hg)** (0,1 %), **Cadmium (Cd)** (0,01 %), **Hexavalent Chromium (Cr⁶⁺)** (0,1 %), **Poly-brominated biphenyls (PBB)** (0,1 %) and **Poly-brominated diphenyl ethers (PBDE)** (0,1 %) (the latter two being families of flame retardants for thermoplastic materials) to which the **Commission Delegated Directive 2015/863/EU** of 2015-03-31 added – with a period of grace of six and a half years – the following ones: **Bis(2-ethylhexyl) phthalate (DEHP)** (0,1 %), **Butyl benzyl phthalate (BBP)** (0,1 %), **Dibutyl phthalate (DBP)** (0,1 %), **Diisobutyl phthalate (DIBP)** (0,1 %).

All ILME finished products (industrial electrical equipment) as well as all ILME components (for industrial electrical equipment) in the sense of the Directive are in conformity with the **RoHS 2 2011/65/EU Directive** and all subsequent modifications within the terms of its scope and the starting dates (transitional periods) established for each category of EEE (electrical and electronic equipment) covered in Annex I of said Directive.

For all components (connector inserts, removable crimp contacts, enclosures for connectors, and accessories related to connectors as far as they are in the scope) the products comply with the limit values for certain substances as set out in said RoHS 2 2011/65/EU Directive and all subsequent modifications, including the permitted exemptions of Annexes III and IV.

Conformity to Directive 2011/65/EU (RoHS II) is intended to the text of the Directive as amended by any applicable later Directive or Commission Delegated Directive associated to it and issued up to the date of this Catalogue (54 documents plus 2 Corrigenda) and to the extent described in the text of this Declaration, including these notes.

Depending on the product, it may make use of exemption 6(b) for lead as an alloying element in aluminium containing up to 0,4% lead by weight (enclosures for multi-pole electrical connectors declared to be made by aluminium die cast alloy, except IP68 series of sizes 44.27 through 104.27 and E-Xtreme® series, which do not use such exemption) or exemption 6(c) for copper alloy containing up to 4% lead by weight (multi-pole connector inserts and removable crimp contacts, except CSH S series, which does not use such exemption as it is not using machined contacts).

NOTE 1 - Expiration of exemption 6(b) has been deferred to 21st July 2021 for our category of products by Commission Delegated Directive (EU) 2018/740; expiration of exemption 6(c) has been deferred to 21st July 2021 for our category of products by Commission Delegated Directive (EU) 2018/741. The above expirations may be subject to further deferment, based on a public enquiry procedure deemed to start on 1st January 2021.

NOTE 2 - Such products by themselves – as components – are not covered by the RoHS 2 Directive; therefore, for such products, there are no direct legal requirements. As no EU Declaration of Conformity can be issued, the above does not constitute a EU Declaration of Conformity to the RoHS 2 2011/65/EU Directive, and the e marking – which may be applied either on the part or on the packaging label in compliance with other applicable EU Directives, e.g. the Low Voltage Directive 2014/35/EU (a recasting of the previous directive 2006/95/EC in force from 2016-04-20) – is not referred to said RoHS 2 Directive.

The **WEEE 2 2012/19/EU Directive** (recast) replaced on 2014-02-15 the original WEEE 2002/96/EC Directive (and its later amendments 2003/108/EC and 2008/34/EC). Its last update is **Directive 2018/849/EU** of 2018-05-30. This Directive aims to recycle and minimise Waste from Electrical and Electronic Equipment (also referred to as WEEE). It encourages recycling, reuse and other forms of recovery of such technological waste and sets ambitious targets for recovery rate, variable depending on the product categories.

In the new Directive, a six-year **transitional period** was established up to 2018-08-14, during which the equipment included in its “open scope” still remained the same as per the former WEEE Directive. From 15th August 2018, the scope became “open”, subject to the exclusions for various categories of “equipment”, which include the **large-scale fixed installations**. *These are defined as “a large-size combination of several types of apparatus and, where applicable, other devices, which: (i) are assembled, installed and uninstalled by professionals; (ii) are intended to be used permanently as part of a building or a structure at a pre-defined and dedicated location; and (iii) can only be replaced by the same specifically designed equipment” and large-scale stationary industrial tools defined as “a large size assembly of machines, equipment, and/or components, functioning together for a specific application, permanently installed and uninstalled by professionals at a given place, and used and maintained by professionals in an industrial manufacturing facility or research and development facility”.*

Connectors and their accessories that, as components, are outside the scope of RoHS 2 Directive, do not fall in the scope of WEEE 2 even once “open scope”; moreover, they are primarily used in installations of industrial automation (large-scale stationary industrial tools) which are exempted from conformity to the WEEE 2 Directive.

As required by the WEEE 2 Directive, ILME will take care of any technical and administrative obligation for any ILME product that might be involved. As a manufacturer of electrical equipment and components for industrial use, ILME acknowledges the regulations introduced by these Directives. The above-mentioned Directives are already effective national law in all EU countries. Similar regional regulations aimed at the preservation of the environment are in force across the world outside Europe. For the products described in this Catalogue, although the restrictions of use of the above-mentioned hazardous substances are not legally applicable, in that no product in this Catalogue belongs to any of the product categories described and illustrated in the above mentioned RoHS 2 and WEEE 2 Directives, the “**RoHS conformity**” is important, as it is required downstream in the supply chain. ILME has therefore carried out the necessary corrective actions, which have led to the “**RoHS conformity**” of all products in this Catalogue, wherever required.

ILME products sold after 1st July 2006 do not contain any of the restricted substances in concentrations higher than those allowed by the RoHS 2 Directive and by the subsequent related Decisions taken by the EU Commission.

FIRE PROTECTION STANDARDS FOR RAILWAY APPLICATIONS

The European standard EN 45545 governing fire protection on railway vehicles was published in 2013. Current editions are:

- **EN 45545-1:2013**, Railway applications – Fire protection on railway vehicles – Part 1: General
- **EN 45545-2:2020+A1:2023**, Railway applications – Fire protection on railway vehicles - Part 2: Requirements for fire behaviour of materials and components
- **EN 45545-3:2024**, Railway applications – Fire protection on railway vehicles – Part 3: Fire resistance requirements for fire barriers
- **EN 45545-4:2024**, Railway applications – Fire protection on railway vehicles – Part 4: Fire safety requirements for rolling stock design
- **EN 45545-5:2013+A1:2015**, Railway applications – Fire protection on railway vehicles - Part 5: Fire safety requirements for electrical equipment including that of trolley buses, track guided buses and magnetic levitation vehicles
- **EN 45545-6:2013**, Railway applications – Fire protection on railway vehicles – Part 6: Fire control and management systems
- **EN 45545-7:2013**, Railway applications – Fire protection on railway vehicles – Part 7: Fire safety requirements for flammable liquid and flammable gas installations

The standard, whose most recent issues are at 2nd edition, replaces the previous voluntary Technical Specification CEN/ TS 45545:2009 and has formalised the withdrawal of all conflicting national standards as of 1st April 2016, the date on which the following parallel standards ceased to be effective: in Italy **UNI CEI 11170-1:2005**, **UNI CEI 11170-2:2005** and **UNI CEI 11170-3:2005**; in France, **NF F 16-101:1988** and **NF F 16-102:1992**; in Germany, **DIN 5510-2:2009**; in United Kingdom, **BS 6853:1999**. These, however, remained applicable until 31st march 2016. All certificates covering materials issued in line with national standards remained valid in Europe up until this date. As of 1st April 2016, the only reference standard was EN 45545:2013, and the subsequent new edition depending on the relevant date of entry into force with a period of grace as defined in each document. However, due to the huge number of customer specifications and technical documents making reference to obsolete standards, the railway business is still moving to a complete unification to the EN 45545 series.

EN 45545-2 specifies the requirements for the fire behaviour of materials and components of railway vehicles according to the different hazard levels defined by EN 45545-1:2013 (**HL** = Hazard Level).

See Table 1 – Hazard level classification (EN 45545-2:2020).

Each hazard level provides for its own specific test procedures, test conditions, fire protection requirements and severity (min or max threshold),

ranging from **R1 to R26**. Electrical components of small size and mass, such as electrical connectors, shall have a nominal fire behaviour rating (self-extinguishing) **94V-0 (standard UL 94)**.

The thermoplastic insulating material used in ILME connectors complies with the requirements of UL 94V-0. There are no requirements applicable to products with a combustible mass < 10 g not in contact with other

unclassified products, if they are installed adjacent to components for which no certificates are available. In this case, the requirements depend on the so-called grouping rules.

Connectors are unlisted products in Table 2 of EN 45545-2:2013.

As non-listed products, they must satisfy the requirements of Table 3, and as their exposed surface area is $\leq 0,2$ m², the set of requirements for

indoor location in a railway vehicle is **R22** while for outdoor location it is **R23** (Table 5 of EN 45545-2:2013).

For the materials of connectors, these are the sets of maximum applicable requirements. These sets establish parameters, procedures and limit thresholds (min or max) for the tests. In particular, R22 and R23 specify tests and limit values for **oxygen content** (oxygen index OI), **smoke density** (Ds max) and **toxicity** (conventional toxicity index CITNLP). **The polycarbonate used by ILME in its connectors meets the limit values specified in EN 45545-2**. See Table 2 – Requirements for unlisted products (including electrical connectors) – at following page.

Until the publication of the previously mentioned series of European standards, the most advanced fire safety standards for the railway industry were French:

- **NF F 16-101** Matériel roulant ferroviaire – Comportement au feu–Choix des matériaux;
- **NF F 16-102** Matériel roulant ferroviaire – Comportement au feu –Choix des équipements électriques; which in turn referred to the test methods described in standards:
- **NF x 70 100** Analyse de gaz de pyrolyse et de combustion;
- **NF x 10 702** Détermination de l'opacité des fumées en atmosphère non renouvelée.

Table 1 – Hazard level classification (EN 45545-2:2020)

Operation Category (#)	Design Category			
	A: Vehicles forming part of an automatic train having no emergency trained staff on board	D: Double decked vehicles	S: Sleeping and couchette vehicles	N: All other vehicles (standard vehicles)
OC 1	HL1	HL1	HL2	HL1
OC 2	HL2	HL2	HL2	HL2
OC 3	HL2	HL2	HL3	HL2
OC 4	HL3	HL3	HL3	HL3

(#) Relationship between the service, the infrastructure and the conditions for the evacuation of passengers and staff

Table 2 – Requirements for unlisted products (including electrical connectors)

Test method	Standard	Parameter	Unit	Interior	Exterior	R22 thresholds (more severe than R23)			ILME (polycarbonate)
						HL1:	HL2:	HL3:	
Oxygen index OI	EN ISO 4589-2	OI (min)	%	R22	R23	HL1: 28	HL2: 28	HL3: 32	better than R22-HL3
Smoke density	EN ISO 5659-2	D _s max ¹⁾	---	R22	R23	HL1: 600	HL2: 300	HL3: 150	better than R22-HL3
Toxicity of smoke	NF X70-100-1 NF X70-100-2	CIT _{NLP} (max) ²⁾	---	R22	R23	HL1: 1,2	HL2: 0,9	HL3: 0,75	better than R22-HL3

¹⁾ D_s max = maximum specific optical density of smoke
²⁾ CIT_{NLP} (max) = maximum conventional index of toxicity of smoke

These latter were somewhat similar, in terms of methods, to the American standards:

- **ASTM E 662** Standard Test Method for Specific Optical Density of Smoke Generated by Solid Materials;
- **ASTM E 162** Standard Test Method for Surface Flammability of Materials Using a Radiant Heat Energy Source.

Test methods referred to in the American reference standard specifying the performance criteria:

- **NFPA 130** Standard for Fixed Guideway Transit and Passenger Rail Systems.

Also widely used are the Bombardier Transportation smoke toxicity specifications:

- **SMP 800-C** Toxic Gas Generation.

In Italy, from 2006 to 31st March 2016, for installation on board railway vehicles, a certificate of conformity to the following Italian railway standards was required:

- **UNI CEI 11170-1:2005** Trains and trams – Fire safety guidelines for trains, trams and track guided vehicles – General principles;
- **UNI CEI 11170-2:2005** Trains and trams – Fire safety guidelines for trains, trams and track guided vehicles – Design recommendations – Fire containment measures – Indication, monitoring and evacuation systems;
- **UNI CEI 11170-3:2005** Trains and trams – Fire safety guidelines for trains, trams and track guided vehicles – Material fire behaviour assessment – Acceptance limits.

Published jointly by UNI and CEI on 2005-11-30 with parallel validity until 31st March 2016. In these standards, the requirements for materials relating to electrical connectors are contained in the 2nd schedule “Acceptability criteria for electrical and electronic materials and components” at the application “All other applications including flammable materials” (all applications other than electric cables). For these applications, four material tests are required:

- Exposure to a small flame according to EN ISO 11925-2 with, depending on the level of risk, a resistance to fire of the material of 15 s for LR1 and LR2 and a resistance of 30 s for LR3 and LR4.
- Smokiness in compliance with French standard NF F 16-101 with IF better or equal to F2 for all risk levels. The material we use is classified as F1 (better than F2) according to the tests carried out.
- Smoke optical density measurement, in compliance with French standard NF × 10-702 (from NF F 16-101) with values ≤ 100 for all risk levels LR1...4.
- Toxicity measurement, in compliance with Italian standard CEI 20-37/7, with T ≤ 2 for all risk levels LR1...4.

Tests

EU – The material tested in accordance with the European Norm **EN 45545-2:2013** – showed an oxygen index (OI) of 38%, a D_s max (flaming) = 117 and a smoke toxicity index CIT_{NLP} = 0,16, **compliant with the requirements of EN 45545-2:2013 for all risk levels: HL1 – HL2 – HL3** and, consequently, for all the design categories (A, D, S, N) and operation categories (1, 2, 3, 4) defined in EN 45545-1:2013.

France – The material used in our connectors is certified by an accredited laboratory CERTIFER, according to the previously mentioned French standards **NF F 16-101** and **NF F 16-102**, and has a **classification F1** (Index Fumée I.F. = 15) and a smoke toxicity index (Index Toxicité Fumée) **I.T.C. = 18**.

Both values meet the requirements set out by the French standards and by the Italian standard UNI CEI 11170-3 schedule 2, which relates to electrical connectors.

Germany – The material used in our connectors also complies with the German standard **DIN 5510-2:2009** with a **flammability class = S4, smoke spreading class = SR2 and drip class = ST2**.

UK – The material was also tested according to British Standard **BS 6853:1999**, with an **R (max) index = 0,6**, consequently within the limits of Tables 7 and 8 of the standard for vehicle categories Ia, Ib and II.

USA – Tests compliant with American standards have also been carried out at a qualified North American laboratory, confirming compliance with the requirements set out by the US Federal Transit Administration “Recommended Fire Safety Practices for Rail Transit Material Selection” for methods ASTM E 662 (NFPA 258) (specific optical smoke density), ASTM E 162 (ASTM D 3635) (surface flammability → flame propagation index) and Bombardier Transportation SMP 800-C (smoke and gas toxicity).

STANDARDS AND CERTIFICATIONS

cULus mark

ILME enclosures have been certified by UL as Recognised Components for the USA and Canada (cULus mark) as accessories of our set of UL and CSA ECBT2/ECBT8 certified connector inserts (file UL E115072, file CSA 082270_0_000). Such enclosures serve as well as accessories for the cULus certified connector inserts in our file E506437 for the PVVA2/PVVA8 product category (UL 2237).

The certification has been achieved by successfully completing several tests carried out in compliance with standard **ANSI/UL 50**, Enclosures for Electrical Equipment and **ANSI/UL 50E** Enclosures for Electrical Equipment, Environmental Considerations which are equivalent to the North American voluntary standard **NEMA 250** (NEMA = National Electrical Manufacturers Association) and to the equivalent Canadian standard **CSA C22.2 No.94** (Special Purpose Enclosures) for safety levels used in North America and required by the local installation codes (e.g.: NFPA 70 National Electrical Code in the US, CSA system standards for Canada); more specifically:

- **Type 12** (= NEMA 12): for internal use, similar to IP54 protection rating according to IEC/EN 60529; it covers Type 1 and Type 2.
- **Type 4** (= NEMA 4): for internal and external use, similar to IP66.
- **Type 4X** (= NEMA 4X): for internal and external use, as Type 4 + corrosion resistance, similar to IP66 protection rating.

Type 4 and Type 4X ratings are now also possible for indoor use only according to **UL 508** and **UL 2237**, for insulating enclosure which are then not required to pass tests for exposure to ultraviolet radiation (which is required for outdoor applications).

The certification includes the enclosure series with ISO, Pg and metric cable entry as well as NPT, all special versions similar to standard types.



SPECIFICATIONS



ISO 23570-3 standard
and DESINA® specification
compliant

Connectors compliant with DESINA® standard

DESINA® (which stands for **DE**centralised and **Standardised INst**allation technology) is an innovative installation concept behind a study headed by the German manufacturers of machine tools association (VDW), with the co-operation of users (including German automotive manufacturers) and component manufacturers, which has led to the introduction of a specification aimed to standardise electrical, hydraulic and pneumatic components and their interconnection on common platform for CNC controlled machine tools and manufacturing lines.

In the last few years, the DESINA® specification has been successfully enclosed in the ISO TC 184/SC 1 "Industrial automation systems and integration / Physical device control" as an ISO standard. This work has been completed, and the following standards have now become available:

ISO 23570-1 Industrial automation systems and integration – Distributed installation in industrial applications: Part 1 – Sensors and actuators.

ISO 23570-2 Industrial automation systems and integration – Distributed installation in industrial applications: Part 2 – Hybrid communication bus.

ISO 23570-3 Industrial automation systems and integration – Distributed installation in industrial applications: Part 3 – Power distribution bus.



EUROMAP (European Plastics and Rubber Machinery)

ILME connectors meet the Technical Recommendations:

- EUROMAP 12: CSAH / CDA / CDC inserts, 32 poles.
- EUROMAP 13: CSAH / CDA / CDC inserts, 16 poles.
- EUROMAP 14 – part 1: CSAH / CDA / CDC inserts, 16 poles (with CDC inserts the iron and constantan thermocouple crimp contacts may also be used).
- EUROMAP 14 – part 2: CSH / CNE / CCE / CSE inserts, 16 poles – CP inserts, 6 poles.
- EUROMAP 16: CD /CDY inserts, 8 poles, CSAH / CDA / CDC inserts, 10 poles.
- EUROMAP 27-1: MIXO inserts, CX 08 C /CY and CX 04 B.
- EUROMAP 28: CNE / CCE / CSH / CSE / CSS inserts, 6 poles.
- EUROMAP 29: CNE / CCE / CSH / CSE / CSS inserts, 24 poles.
- EUROMAP 62: CSAH / CDA / CDC inserts, 32 poles.
- EUROMAP 67: CD inserts, 50 poles (CD 25 Z version).
- EUROMAP 67.1: CD inserts, 50 poles (CD 25 Z version).
- EUROMAP 70: MIXO inserts, CX 12 D /DY.
- EUROMAP 71: CD inserts, 50 poles (CD 25 Z version).
- EUROMAP 73: MIXO inserts, CX 12 D /DY.
- EUROMAP 74: MIXO inserts, CX 12 D /DY.
- EUROMAP 78: MIXO inserts, CX 12 D /DY.
- EUROMAP 81.1: MIXO inserts CX 08 C /CY
- EUROMAP 81.2: MIXO inserts CX 08 C /CX + CX 12 D /DY

INDEX OF PART NUMBERS

A

AH M25IF.....	E.249	C7P 16.....	E.126	CAO 24 X.....	E.75	CAP 24.21.....	E.72
AH M25IFL.....	E.249	C7P 16.2.....	E.126	CAO 24 X29.....	E.75	CAP 24.29.....	E.72
AH M32IF.....	E.249	C7P 24.....	E.127	CAO 24 YX21.....	E.261	CAP 24.221.....	E.72
AH M32IFL.....	E.249	C7P 24.2.....	E.127	CAO 24 YX29.....	E.261	CAP 24.229.....	E.72
AT 8FT.....	A.43	C13D 16 C.....	F.24*	CAOW 06 L21.....	E.155	CAP 24 CP.....	E.74
AT 8IFT.....	A.43	C13D 25 C.....	F.24*	CAOW 10.21.....	E.157	CAP 24 CP2.....	E.74
AT LCMM.....	A.43	C13D 35 C.....	F.24*	CAOW 16.29.....	E.159	CAP 24 CP29.....	E.74
AT LCSM.....	A.43	C13D 50 C.....	F.24*	CAOW 24.29.....	E.161	CAP 24 CP229.....	E.74
ATR C22.....	A.43	C13D 70 C.....	F.24*	CAO W50.29.....	E.32	CAP 24 CS.....	E.74
AT U2F.....	A.43	C13D 95 C.....	F.24*	CAP 06 L.....	E.48	CAP 24 CS2.....	E.74
AT U3F.....	A.43	C13D 120 C.....	F.24*	CAP 06 L2.....	E.48	CAP 24 CS29.....	E.74
AW M25IJ.....	A.33	C13PZ C.....	F.24	CAP 06 L29.....	E.48	CAP 24 CS229.....	E.74
AW M25INJ.....	A.33	C13PZE C AU.....	F.25	CAP 06 L229.....	E.48	CAP 24 G36.....	G.35
AW M25PJ.....	A.33	C13PZE C EU.....	F.25	CAP 06 LS.....	E.48	CAP 24 L.....	E.70
		C13PZE C UK.....	F.25	CAP 06 LS2.....	E.48	CAP 24 L2.....	E.70
		C13PZE C US.....	F.25	CAP 06 LS29.....	E.48	CAP 24 L29.....	E.70
		C30FA 16.....	C.12*, F.6	CAP 06 LS229.....	E.48	CAP 24 L229.....	E.70
		C30FA 25.....	C.12*, F.6	CAP 06 YC229.....	E.254	CAP 24 LS.....	E.70
		C30FA 35.....	C.12*, F.6	CAP 10.21.....	E.56	CAP 24 LS2.....	E.70
		C30FA 50.....	C.12*, F.6	CAP 10.29.....	E.56	CAP 24 LS29.....	E.70
		C30FA 70.....	C.12*, F.6	CAP 10.221.....	E.56	CAP 24 LS229.....	E.70
		C30FA 95.....	C.12*, F.6	CAP 10.229.....	E.56	CAP 24 YC229.....	E.260
		C30FA 120.....	C.12*, F.6	CAP 10 CP.....	E.58	CAPS 06 L.....	E.216
		C30MA 16.....	C.13, F.6	CAP 10 CP2.....	E.58	CAPS 10.21.....	E.217
		C30MA 16 P.....	C.12, F.6	CAP 10 CP29.....	E.58	CAPS 16.21.....	E.218
		C30MA 25.....	C.13, F.6	CAP 10 CP229.....	E.58	CAPS 24.21.....	E.219
		C30MA 25 P.....	C.12, F.6	CAP 10 CS.....	E.58	CAPW 06 L.....	E.162
		C30MA 35.....	C.13, F.6	CAP 10 CS2.....	E.58	CAPW 10.21.....	E.163
		C30MA 35 P.....	C.12, F.6	CAP 10 CS29.....	E.58	CAPW 16.21.....	E.164
		C30MA 50.....	C.13, F.6	CAP 10 CS229.....	E.58	CAPW 24.21.....	E.165
		C30MA 50 P.....	C.12, F.6	CAP 10 L.....	E.54	CAV 06 YX21.....	E.255
		C30MA 70.....	C.13, F.6	CAP 10 L2.....	E.54	CAV 06 YX29.....	E.255
		C30MA 70 P.....	C.12, F.6	CAP 10 L29.....	E.54	CAV 10 X.....	E.59
		C30MA 95.....	C.13, F.6	CAP 10 L229.....	E.54	CAV 10 X29.....	E.59
		C30MA 95 P.....	C.12, F.6	CAP 10 LS.....	E.54	CAV 10 YX21.....	E.257
		C30MA 120.....	C.13, F.6	CAP 10 LS2.....	E.54	CAV 10 YX29.....	E.257
		C30MA 120 P.....	C.12, F.6	CAP 10 LS29.....	E.54	CAV 16 X.....	E.67
		CAC 06 L.....	E.49	CAP 10 LS229.....	E.54	CAV 16 X29.....	E.67
		CAC 10.....	E.57	CAP 10 YC229.....	E.256	CAV 16 YX21.....	E.259
		CAC 10 L.....	E.55	CAP 16.21.....	E.64	CAV 16 YX29.....	E.259
		CAC 16.....	E.65	CAP 16.29.....	E.64	CAV 24 X.....	E.75
		CAC 16 L.....	E.63	CAP 16.221.....	E.64	CAV 24 X29.....	E.75
		CAC 24.....	E.73	CAP 16.229.....	E.64	CAV 24 YX21.....	E.261
		CAC 24 L.....	E.71	CAP 16 CP.....	E.66	CAV 24 YX29.....	E.261
		CAC 50.....	E.21	CAP 16 CP2.....	E.66	CAVW 06 L21.....	E.155
		CACR 06 L.....	I.19	CAP 16 CP29.....	E.66	CAVW 06 LG.....	E.162
		CACR 10.....	I.21	CAP 16 CP229.....	E.66	CAVW 10.21.....	E.157
		CACR 16.....	I.23	CAP 16 CS.....	E.66	CAVW 10 G.....	E.163
		CACR 24.....	I.25	CAP 16 CS2.....	E.66	CAVW 16.29.....	E.159
		CAN 24.....	E.77	CAP 16 CS29.....	E.66	CAVW 16 G29.....	E.164
		CAO 06 YX21.....	E.255	CAP 16 CS229.....	E.66	CAVW 24.29.....	E.161
		CAO 06 YX29.....	E.255	CAP 16 L.....	E.62	CAVW 24 G.....	E.165
		CAO 10 X.....	E.59	CAP 16 L2.....	E.62	CAVW 50.29.....	E.32
		CAO 10 X29.....	E.59	CAP 16 L29.....	E.62	CAVX 50 G29.....	E.24
		CAO 10 YX21.....	E.257	CAP 16 L229.....	E.62	CBC 06 L.....	E.268
		CAO 10 YX29.....	E.257	CAP 16 LS.....	E.62	CBC 10.....	E.269
		CAO 16 X.....	E.67	CAP 16 LS2.....	E.62	CBC 16.....	E.270
		CAO 16 X29.....	E.67	CAP 16 LS29.....	E.62	CBC 24.....	E.271
		CAO 16 YX21.....	E.259	CAP 16 LS229.....	E.62	CBGF.....	G.31
		CAO 16 YX29.....	E.259	CAP 16 YC229.....	E.258	CC 0.5 AN.....	A.8, B.9*, C.39*, F.11

* These items are also shown in various sections throughout the catalogue

CC 0.7 AN	A.8, B.9*, C.39*, F.11	CCM2D 0.3	F.13	CCTPADM	F.38	CDFA 0.7	A.7*, B.6*, C.35*, F.14
CC 1.0 AN	A.8, B.9*, C.39*, F.11	CCM2D 0.5	F.13	CCVPP	F.32*	CDFA 1.0	A.7*, B.6*, C.35*, F.14
CC 1.5 AN	A.8, B.9*, C.39*, F.11	CCM2D 0.7	F.13	CCW CT	F.62	CDFA 1.5	A.7*, B.6*, C.35*, F.14
CC 2.5 AN	A.8, B.9*, C.39*, F.11	CCM2D 1.0	F.13	CCW M20	F.62	CDFA 2.5	A.7*, B.6*, C.35*, F.14
CCEF 06	B.44	CCM2D 1.5	F.13	CCW M25	F.62	CDFA 6A	D.14
CCEF 10	B.45	CCM2D 2.5	F.13	CCW M32	F.62	CDFA 6A28	D.4*
CCEF 16	B.46*	CCM2D 3.0	F.13	CCW PD 1M	F.62	CDFD 0.3	A.10*, B.6*, C.35*, F.14
CCEF 16 N	B.48	CCM2D 4.0	F.13	CCW PD 2MIAP	F.62	CDFD 0.5	A.10*, B.6*, C.35*, F.14
CCEF 24	B.47*	CCMA 0.3	A.8, B.9*, C.39*, F.11	CCW PD 03	F.62	CDFD 0.7	A.10*, B.6*, C.35*, F.14
CCEF 24 N	B.49	CCMA 0.5	A.8, B.9*, C.39*, F.11	CCW PD 03.4	F.62	CDFD 1.0	A.10*, B.6*, C.35*, F.14
CCEM 06	B.44	CCMA 0.7	A.8, B.9*, C.39*, F.11	CCW PD 03G	F.62	CDFD 1.5	A.10*, B.6*, C.35*, F.14
CCEM 10	B.45	CCMA 1.0	A.8, B.9*, C.39*, F.11	CCW PD 03IVG	F.62	CDFD 2.5	A.10*, B.6*, C.35*, F.14
CCEM 16	B.46*	CCMA 1.5	A.8, B.9*, C.39*, F.11	CCW PD 06	F.62	CDFD 6A	D.14
CCEM 16 N	B.48	CCMA 2.5	A.8, B.9*, C.39*, F.11	CCW PD 08	F.62	CDFJD 0.3	F.16
CCEM 24	B.47*	CCMA 3.0	A.8, B.9*, C.39*, F.11	CCW PD 10	F.62	CDFJD 0.5	F.16
CCEM 24 N	B.49	CCMA 4.0	A.8, B.9*, C.39*, F.11	CCW PD 15	F.62	CDFJD 0.7	F.16
CCES	F.55	CCMC 0.3	F.20	CCW PD 16	F.62	CDFJD 1.0	F.16
CCF2D 0.3	F.13	CCMC 0.5	F.20	CCW PD 24	F.62	CDFJD 1.5	F.16
CCF2D 0.5	F.13	CCMD 0.3	A.8, B.9*, C.39*, F.11	CCW PD 25	F.62	CCFJJD 2.5	F.16
CCF2D 0.7	F.13	CCMD 0.5	A.8, B.9*, C.39*, F.11	CDAF 10	B.16	CDFS 0.3	F.15
CCF2D 1.0	F.13	CCMD 0.7	A.8, B.9*, C.39*, F.11	CDAF 10 X	B.16	CDFS 0.5	F.15
CCF2D 1.5	F.13	CCMD 1.0	A.8, B.9*, C.39*, F.11	CDAF 16	B.17*	CDFS 0.7	F.15
CCF2D 2.5	F.13	CCMD 1.5	A.8, B.9*, C.39*, F.11	CDAF 16 N	B.18	CDFS 1.0	F.15
CCF2D 3.0	F.13	CCMD 2.5	A.8, B.9*, C.39*, F.11	CDAF 16 X	B.17*	CDFS 1.5	F.15
CCF2D 4.0	F.13	CCMD 3.0	A.8, B.9*, C.39*, F.11	CDAF 16 XN	B.18	CDFS 2.5	F.15
CCFA 0.3	A.8, B.9*, C.39*, F.11	CCMD 4.0	A.8, B.9*, C.39*, F.11	CDAM 10	B.16	CDM2D 0.3	F.16
CCFA 0.5	A.8, B.9*, C.39*, F.11	CCMF 0.3	F.20	CDAM 10 X	B.16	CDM2D 0.5	F.16
CCFA 0.7	A.8, B.9*, C.39*, F.11	CCMF 0.5	F.20	CDAM 16	B.17*	CDM2D 0.7	F.16
CCFA 1.0	A.8, B.9*, C.39*, F.11	CCMFA	D.4*	CDAM 16 N	B.18	CDM2D 1.0	F.16
CCFA 1.5	A.8, B.9*, C.39*, F.11	CCMJD 0.3	F.13	CDAM 16 X	B.17*	CDM2D 1.5	F.16
CCFA 2.5	A.8, B.9*, C.39*, F.11	CCMJD 0.5	F.13	CDAM 16 XN	B.18	CDM2D 2.5	F.16
CCFA 3.0	A.8, B.9*, C.39*, F.11	CCMJD 0.7	F.13	CDCF 10	B.19	CDM 07	A.22
CCFA 4.0	A.8, B.9*, C.39*, F.11	CCMJD 1.0	F.13	CDCF 16	B.20*	CDM 07 N	A.22
CCFC 0.3	F.20	CCMJD 1.5	F.13	CDCF 16 N	B.21	CDM 08	A.24, H.9
CCFC 0.5	F.20	CCMJD 2.5	F.13	CDCM 10	B.19	CDM 15	B.30
CCFD 0.3	A.8, B.9*, C.39*, F.11	CCMJD 3.0	F.13	CDCM 16	B.20*	CDM 25	B.31*
CCFD 0.5	A.8, B.9*, C.39*, F.11	CCMJD 4.0	F.13	CDCM 16 N	B.21	CDM 25 Z	B.32
CCFD 0.7	A.8, B.9*, C.39*, F.11	CCMS 0.3	F.12	CDDF 24	B.94	CDM 40	B.90*
CCFD 1.0	A.8, B.9*, C.39*, F.11	CCMS 0.5	F.12	CDDF 38	B.33*	CDM 64	B.91*
CCFD 1.5	A.8, B.9*, C.39*, F.11	CCMS 0.7	F.12	CDDF 42	B.95	CDMA 0.3	A.7*, B.6*, C.35*, F.14
CCFD 2.5	A.8, B.9*, C.39*, F.11	CCMS 1.0	F.12	CDDF 72	B.96*	CDMA 0.5	A.7*, B.6*, C.35*, F.14
CCFD 3.0	A.8, B.9*, C.39*, F.11	CCMS 1.5	F.12	CDDF 72 N	B.98	CDMA 0.7	A.7*, B.6*, C.35*, F.14
CCFD 4.0	A.8, B.9*, C.39*, F.11	CCMS 2.5	F.12	CDDF 108	B.97*	CDMA 1.0	A.7*, B.6*, C.35*, F.14
CCFF 0.3	F.20	CCMS 3.0	F.12	CDDF 108 N	B.99	CDMA 1.5	A.7*, B.6*, C.35*, F.14
CCFF 0.5	F.20	CCMS 4.0	F.12	CDDM 24	B.94	CDMA 2.5	A.7*, B.6*, C.35*, F.14
CCFFA	D.4*	CCPNP	F.34*	CDDM 38	B.33*	CDMA 6A	D.4*
CCFJD 0.3	F.13	CCPNP RN	F.40*	CDDM 42	B.95	CDMA 6A32	D.14
CCFJD 0.5	F.13	CCPR RN	F.55	CDDM 72	B.96*	CDMD 0.3	A.10*, B.6*, C.35*, F.14
CCFJD 0.7	F.13	CCPZEB1.5 RN	F.42	CDDM 72 N	B.98	CDMD 0.5	A.10*, B.6*, C.35*, F.14
CCFJD 1.0	F.13	CCPZEB3.0 RN	F.42	CDDM 108	B.97*	CDMD 0.7	A.10*, B.6*, C.35*, F.14
CCFJD 1.5	F.13	CCPZE RN	F.42	CDDM 108 N	B.99	CDMD 1.0	A.10*, B.6*, C.35*, F.14
CCFJD 2.5	F.13	CCPZE RN AU	F.42	CDF2D 0.3	F.16	CDMD 1.5	A.10*, B.6*, C.35*, F.14
CCFJD 3.0	F.13	CCPZE RN EU	F.42	CDF2D 0.5	F.16	CDMD 2.5	A.10*, B.6*, C.35*, F.14
CCFJD 4.0	F.13	CCPZE RN UK	F.42	CDF2D 0.7	F.16	CDMD 6A	D.14
CCFPZ M1	G.29	CCPZE RN US	F.42	CDF2D 1.0	F.16	CDMJD 0.3	F.16
CCFPZ M2	G.29	CCPZ MIL	F.34	CDF2D 1.5	F.16	CDMJD 0.5	F.16
CCFPZ M3	G.29	CCPZP	F.36	CDF2D 2.5	F.16	CDMJD 0.7	F.16
CCFPZ M4	G.29	CCPZPA	F.38	CDF 07	A.22	CDMJD 1.0	F.16
CCFS 0.3	F.12	CCPZP RN	F.43	CDF 07 N	A.22	CDMJD 1.5	F.16
CCFS 0.5	F.12	CCPZ RN	F.40	CDF 08	A.24, H.9	CDMJD 2.5	F.16
CCFS 0.7	F.12	CCPZ TP	F.47	CDF 15	B.30	CDMS 0.3	F.15
CCFS 1.0	F.12	CCSPZP	F.32*	CDF 25	B.31*	CDMS 0.5	F.15
CCFS 1.5	F.12	CCTP 10	F.34*	CDF 25 Z	B.32	CDMS 0.7	F.15
CCFS 2.5	F.12	CCTP 16	F.34*	CDF 40	B.90*	CDMS 1.0	F.15
CCFS 3.0	F.12	CCTPACF	F.38	CDF 64	B.91*	CDMS 1.5	F.15
CCFS 4.0	F.12	CCTPACM	F.38	CDFA 0.3	A.7*, B.6*, C.35*, F.14	CDMS 2.5	F.15
CCINA	F.55	CCTPADF	F.38	CDFA 0.5	A.7*, B.6*, C.35*, F.14	CDSHF 06 NC	B.108

* These items are also shown in various sections throughout the catalogue

CDSHF 09.....	B.102	CFV 10 LG21	E.54	CGCP 10 MB.....	G.47	CGO 24.29 B.....	E.149
CDSHF 18.....	B.103	CFV 10 LG29.....	E.54	CGCP 16 FX.....	G.47	CGO 24.36.....	E.148
CDSHF 27.....	B.104*	CFV 16.21.....	E.65	CGCP 16 MB.....	G.47	CGO 24.36 B.....	E.149
CDSHF 27 N.....	B.106	CFV 16.29.....	E.65	CGCP 24 FX.....	G.47	CGP 06.29.....	E.142
CDSHF 42.....	B.105*	CFV 16.216.....	E.69	CGCP 24 MB.....	G.47	CGP 10.29.....	E.144
CDSHF 42 N.....	B.107	CFV 16.221.....	E.69	CGD 10 C.....	F.26*	CGP 16.36.....	E.146
CDSHM 06 NC.....	B.108	CFV 16 G.....	E.64	CGD 10EH C.....	F.29	CGP 24.36.....	E.148
CDSHM 09.....	B.102	CFV 16 G29.....	E.64	CGD 16 C.....	F.26*	CGP 24.236.....	E.148
CDSHM 18.....	B.103	CFV 16 GYC21.....	E.258	CGD 16EH C.....	F.29	CGPZEH LOC.....	F.29
CDSHM 27.....	B.104*	CFV 16 GYC29.....	E.258	CGD 25 C.....	F.26*	CGPZ LOC.....	F.26*
CDSHM 27 N.....	B.106	CFV 16 L21.....	E.63	CGD 25EH C.....	F.29	CGT 6.0.....	C.96, H.63
CDSHM 42.....	B.105*	CFV 16 L29.....	E.63	CGD 35 C.....	F.26*	CGT 10.....	C.96, H.63
CDSHM 42 N.....	B.107	CFV 16 LG21.....	E.62	CGD 35EH C.....	F.29	CGT 16.....	C.96, H.63
CDYF 07.....	A.23	CFV 16 LG29.....	E.62	CGFA 10.....	B.156*, C.20*, F.8	CGT 25.....	C.96, H.63
CDYF 08.....	A.25	CFV 24.21.....	E.73	CGFA 16.....	B.156*, C.20*, F.8	CGV 06.16.....	E.142
CDYM 07.....	A.23	CFV 24.29.....	E.73	CGFA 25.....	B.156*, C.20*, F.8	CGV 06.16 B.....	E.143
CDYM 08.....	A.25	CFV 24.221.....	E.77	CGFA 35.....	B.156*, C.20*, F.8	CGV 06.21.....	E.142
CFF 10.....	E.61	CFV 24 G.....	E.72	CGI 06.....	E.142	CGV 06.21 B.....	E.143
CFF 16.....	E.69	CFV 24 G29.....	E.72	CGI 06 B.....	E.143	CGV 06.29.....	E.142
CFF 16.221.....	E.69	CFV 24 GYC21.....	E.260	CGI 10.....	E.144	CGV 06.29 B.....	E.143
CFF 24.....	E.77	CFV 24 GYC29.....	E.260	CGI 10 B.....	E.145	CGV 10.16.....	E.144
CFF 24.221.....	E.77	CFV 24 L21.....	E.71	CGI 16.....	E.146	CGV 10.16 B.....	E.145
CFO 06 L21.....	E.49	CFV 24 L29.....	E.71	CGI 16 B.....	E.147	CGV 10.21.....	E.144
CFO 06 L29.....	E.49	CFV 24 LG21.....	E.70	CGI 24.....	E.148	CGV 10.21 B.....	E.145
CFO 10.21.....	E.57	CFV 24 LG29.....	E.70	CGI 24 B.....	E.149	CGV 10.29.....	E.144
CFO 10.29.....	E.57	CFV 32.....	E.81	CGIE 06.....	E.194	CGV 10.29 B.....	E.145
CFO 10 L2.....	E.55	CFV 32.29.....	E.81	CGIE 10.....	E.195	CGV 16.21.....	E.146
CFO 10 L29.....	E.55	CFV 32.42.....	E.81	CGIE 16.....	E.196	CGV 16.21 B.....	E.147
CFO 16.21.....	E.65	CFV 32 G.....	E.80	CGIE 24.....	E.197	CGV 16.29.....	E.146
CFO 16.29.....	E.65	CFV 32 G29.....	E.80	CGK C.....	A.81	CGV 16.29 B.....	E.147
CFO 16 L21.....	E.63	CFV 32 G42.....	E.80	CGK C6.....	A.81	CGV 16.36.....	E.146
CFO 16 L29.....	E.63	CFV 32 LG.....	E.78	CGK C B.....	A.81	CGV 16.36 B.....	E.147
CFO 24.21.....	E.73	CFV 32 X.....	E.82	CGK CG.....	A.81	CGV 16.221.....	E.146
CFO 24.29.....	E.73	CFV 48 L.....	E.85	CGK CG B.....	A.81	CGV 16.221 B.....	E.147
CFO 24 L21.....	E.71	CFV 48 L29.....	E.85	CGKCP FX.....	G.47	CGV 24.21.....	E.148
CFO 24 L29.....	E.71	CFV 48 L42.....	E.85	CGKCP MB.....	G.47	CGV 24.21 B.....	E.149
CFO 32.....	E.81	CFV 50.21.....	E.21	CGK I.....	A.78	CGV 24.29.....	E.148
CFO 32.29.....	E.81	CFV 50.29.....	E.21	CGK IA.....	A.78	CGV 24.29 B.....	E.149
CFO 32.42.....	E.81	CFV 50 G29.....	E.20	CGK IAP13.....	A.78	CGV 24.36.....	E.148
CFO 32 L.....	E.79	CFV 50 X.....	E.23	CGK I B.....	A.79	CGV 24.36 B.....	E.149
CFO 32 X.....	E.82	CFV 50 X29.....	E.23	CGK V13.....	A.78	CGV 24.229.....	E.148
CFO 48 L.....	E.85	CFVS 06 L21.....	E.209	CGK V13 B.....	A.79	CGV 24.229 B.....	E.149
CFO 48 L29.....	E.85	CFVS 10.21.....	E.211	CGMA 10.....	B.156*, C.20*, F.8	CH1ES.....	F.56
CFO 48 L42.....	E.85	CFVS 16.29.....	E.213	CGMA 16.....	B.156*, C.20*, F.8	CHC 06 L.....	E.52
CFO 50.21.....	E.21	CFVS 24.29.....	E.215	CGMA 25.....	B.156*, C.20*, F.8	CHC 06 LC.....	E.52
CFO 50.29.....	E.21	CG 06 FL.....	G.45	CGMA 35.....	B.156*, C.20*, F.8	CHC 06 LG.....	E.52
CFO 50 X.....	E.23	CG 10 FL.....	G.45	CGO 06.16.....	E.142	CHC 06 SL.....	E.52
CFO 50 X29.....	E.23	CG 16 FL.....	G.45	CGO 06.16 B.....	E.143	CHC 10.....	E.60
CFOS 06 L21.....	E.209	CG 24 FL.....	G.45	CGO 06.21.....	E.142	CHC 10 C.....	E.60
CFOS 10.21.....	E.211	CGC 06.....	E.142	CGO 06.21 B.....	E.143	CHC 10 G.....	E.60
CFOS 16.29.....	E.213	CGC 06 B.....	E.143	CGO 06.29.....	E.142	CHC 10 L.....	E.60
CFOS 24.29.....	E.215	CGC 06 G.....	E.142	CGO 06.29 B.....	E.143	CHC 10 LG.....	E.60
CFV 06 GYC21.....	E.254	CGC 10.....	E.142*	CGO 10.16.....	E.144	CHC 10 S.....	E.60
CFV 06 GYC29.....	E.254	CGC 10 B.....	E.145	CGO 10.16 B.....	E.145	CHC 10 SL.....	E.60
CFV 06 L21.....	E.49	CGC 10 G.....	E.144	CGO 10.21.....	E.144	CHC 16.....	E.68
CFV 06 L29.....	E.49	CGC 16 B.....	E.147	CGO 10.21 B.....	E.145	CHC 16 C.....	E.68
CFV 06 LG21.....	E.48	CGC 16 G.....	E.146	CGO 10.29.....	E.144	CHC 16 G.....	E.68
CFV 06 LG29.....	E.48	CGC 24.....	E.148	CGO 10.29 B.....	E.145	CHC 16 L.....	E.68
CFV 10.21.....	E.57	CGC 24 B.....	E.149	CGO 16.21.....	E.146	CHC 16 LG.....	E.68
CFV 10.29.....	E.57	CGC 24 G.....	E.148	CGO 16.21 B.....	E.147	CHC 16 S.....	E.68
CFV 10.213.....	E.61	CGCE 06.....	E.194	CGO 16.29.....	E.146	CHC 16 SL.....	E.68
CFV 10 G.....	E.56	CGCE 10.....	E.195	CGO 16.29 B.....	E.147	CHC 24.....	E.76
CFV 10 G29.....	E.56	CGCE 16.....	E.196	CGO 16.36.....	E.146	CHC 24 C.....	E.76
CFV 10 GYC21.....	E.256	CGCE 24.....	E.197	CGO 16.36 B.....	E.147	CHC 24 G.....	E.76
CFV 10 GYC29.....	E.256	CGCP 06 FX.....	G.47	CGO 24.21.....	E.148	CHC 24 L.....	E.76
CFV 10 L21.....	E.55	CGCP 06 MB.....	G.47	CGO 24.21 B.....	E.149	CHC 24 LG.....	E.76
CFV 10 L29.....	E.55	CGCP 10 FX.....	G.47	CGO 24.29.....	E.148	CHC 24 S.....	E.76

* These items are also shown in various sections throughout the catalogue

CHC 24 SL	E.76	CHCW 24	E.161	CHIR 32 LS	I.26	CHP 24 CP	E.74
CHC 32	E.83	CHCW 24 G	E.165	CHIR 48 L	I.27	CHP 24 CP2	E.74
CHC 32 C	E.83	CHCW 24 S	E.161	CHIR 48 LS	I.27	CHP 24 CS	E.74
CHC 32 G	E.83	CHCW 32	E.167	CHIS 06 L	E.216	CHP 24 CS2	E.74
CHC 32 L	E.83	CHCW 32 G	E.166	CHIS 10	E.217	CHP 24 L	E.70
CHC 32 LG	E.83	CHCW 32 S	E.167	CHIS 16	E.218	CHP 24 L2	E.70
CHC 32 S	E.83	CHCW 50	E.32	CHIS 24	E.219	CHP 24 LS	E.70
CHC 32 SL	E.83	CHCW 50 G	E.32	CHIW 06 L	E.162	CHP 24 LS2	E.70
CHC 50	E.21	CHCW 50 S	E.32	CHIW 10	E.163	CHP 32	E.80
CHC 50 G	E.20	CHCX 50 G	E.24	CHIW 16	E.164	CHP 32.2	E.80
CHC 50 S	E.21	CHCXW 50 G	E.33	CHIW 24	E.165	CHP 32.29	E.80
CHCE 06 L	E.183	CHES	F.56	CHIW 32	E.166	CHP 32.42	E.80
CHCE 06 LG	E.182	CHI 06 L	E.48	CHIW 48 LS	E.168	CHP 32.229	E.80
CHCE 06 SL	E.183	CHI 06 LC	E.50	CHIW 50	E.32	CHP 32.242	E.80
CHCE 10	E.185	CHI 06 LCH	G.34	CHIX 32 L	E.78	CHP 32 L	E.78
CHCE 10 G	E.184	CHI 06 LCP	E.50	CHIX 32 LP	E.78	CHP 32 L2	E.78
CHCE 10 S	E.185	CHI 06 LCS	E.50	CHIX 32 LS	E.78	CHP 32 L29	E.78
CHCE 16	E.187	CHI 06 LS	E.48	CHIX 50	E.24	CHP 32 L42	E.78
CHCE 16 G	E.186	CHI 06 YC	E.254	CHIXW 50	E.33	CHP 32 L229	E.78
CHCE 16 S	E.187	CHI 10	E.56	CHO 06 L13	E.49	CHP 32 L242	E.78
CHCE 24	E.189	CHI 10 C	E.58	CHO 06 L16	E.49	CHP 32 LS	E.78
CHCE 24 G	E.188	CHI 10 CH	G.34	CHO 06 LX16	E.51	CHP 32 LS2	E.78
CHCE 24 S	E.189	CHI 10 CP	E.58	CHO 10	E.57	CHP 32 LS29	E.78
CHCE 32	E.191	CHI 10 CS	E.58	CHO 10 L16	E.55	CHP 32 LS42	E.78
CHCE 32 G	E.190	CHI 10 L	E.54	CHO 10 X	E.59	CHP 32 LS229	E.78
CHCE 32 S	E.191	CHI 10 LS	E.54	CHO 16	E.65	CHP 32 LS242	E.78
CHCE 50	E.39	CHI 10 YC	E.256	CHO 16 L	E.63	CHP 48 LS	E.84
CHCE 50 G	E.38	CHI 16	E.64	CHO 16 X	E.67	CHP 48 LS29	E.84
CHCE 50 S	E.39	CHI 16 C	E.66	CHO 24	E.73	CHP 50.21	E.20
CHCN 06 L	E.297	CHI 16 CH	G.34	CHO 24 L	E.71	CHP 50.29	E.20
CHCN 06 LG	E.296	CHI 16 CP	E.66	CHO 24 X	E.75	CHP 50.221	E.20
CHCN 10	E.299	CHI 16 CS	E.66	CHO 50	E.21	CHP 50.229	E.20
CHCN 10 G	E.298	CHI 16 L	E.62	CHO 50 X	E.23	CHP 50 LS21	E.22
CHCN 16	E.301	CHI 16 LS	E.62	CHOS 16	E.213	CHP 50 LS29	E.22
CHCN 16 G	E.300	CHI 16 YC	E.258	CHOS 24	E.215	CHP 50 LS221	E.22
CHCN 24	E.303	CHI 24	E.72	CHOW 16	E.159	CHP 50 LS229	E.22
CHCN 24 G	E.302	CHI 24 C	E.74	CHOW 24	E.161	CHPW 32	E.166
CHCP 06	G.46	CHI 24 CH	G.34	CHOW 32	E.167	CHPW 48 LS	E.168
CHCP 10	G.46	CHI 24 CP	E.74	CHOW 48 L	E.169	CHPW 50.21	E.32
CHCP 10 V	G.46	CHI 24 CS	E.74	CHOW 50	E.32	CHPW 50.229	E.32
CHCP 16	G.46	CHI 24 L	E.70	CHOX 50 X	E.25	CHPX 32 L	E.78
CHCP 24	G.46	CHI 24 LS	E.70	CHP 06 L	E.48	CHPX 32 L29	E.78
CHCR 06 L	I.19	CHI 24 YC	E.260	CHP 06 L2	E.48	CHPX 32 LP	E.78
CHCR 10	I.21	CHI 32	E.80	CHP 06 LS	E.48	CHPX 32 LP29	E.78
CHCR 16	I.23	CHI 32 CS	E.82	CHP 06 LS2	E.48	CHPX 32 LS	E.78
CHCR 24	I.25	CHI 32 L	E.78	CHP 10	E.56	CHPX 32 LS29	E.78
CHCS 06 L	E.209	CHI 32 LS	E.78	CHP 10.2	E.56	CHPX 50.21	E.24
CHCS 06 LG	E.216	CHI 48 L	E.84	CHP 10 CP	E.58	CHPX 50.29	E.24
CHCS 06 SL	E.209	CHI 48 LS	E.84	CHP 10 CP2	E.58	CHPXW 50.21	E.33
CHCS 10	E.211	CHI 50	E.20	CHP 10 CS	E.58	CHSDS	G.42
CHCS 10 G	E.217	CHI 50 CS	E.22	CHP 10 CS2	E.58	CHV 06 L13	E.49
CHCS 10 S	E.211	CHIE 06 L	E.182	CHP 10 L	E.54	CHV 06 L16	E.49
CHCS 16	E.213	CHIE 10	E.184	CHP 10 L2	E.54	CHV 06 LG	E.48
CHCS 16 G	E.218	CHIE 16	E.186	CHP 10 LS	E.54	CHV 06 LX16	E.51
CHCS 16 S	E.213	CHIE 24	E.188	CHP 10 LS2	E.54	CHV 10	E.57
CHCS 24	E.215	CHIE 32	E.190	CHP 16	E.64	CHV 10 G	E.56
CHCS 24 G	E.219	CHIE 48 LS	E.192	CHP 16.2	E.64	CHV 10 L	E.55
CHCS 24 S	E.215	CHIE 50	E.38	CHP 16 CP	E.66	CHV 10 LG	E.54
CHCW 06 L	E.155	CHIN 06 L	E.296	CHP 16 CP2	E.66	CHV 10 X	E.59
CHCW 06 LG	E.162	CHIN 06 LCH	E.297	CHP 16 CS	E.66	CHV 16	E.65
CHCW 06 SL	E.155	CHIN 10	E.298	CHP 16 CS2	E.66	CHV 16 G	E.64
CHCW 10	E.157	CHIN 10 CH	E.299	CHP 16 L	E.62	CHV 16 L	E.63
CHCW 10 G	E.163	CHIN 16	E.300	CHP 16 L2	E.62	CHV 16 LG	E.62
CHCW 10 S	E.157	CHIN 16 CH	E.301	CHP 16 LS	E.62	CHV 16 X	E.67
CHCW 16	E.159	CHIN 24	E.302	CHP 16 LS2	E.62	CHV 24	E.73
CHCW 16 G	E.164	CHIN 24 CH	E.303	CHP 24	E.72	CHV 24 G	E.72
CHCW 16 S	E.159	CHIR 32 L	I.26	CHP 24.2	E.72	CHV 24 L	E.71

* These items are also shown in various sections throughout the catalogue

CHV 24 LG.....	E.70	CJK 8P IFT.....	A.32	CKAX 03 ILS.....	A.56*	CKX 03 VG.....	A.55
CHV 24 X.....	E.75	CJ KF.....	A.30	CKAX 03 ILSA.....	A.56	CKX 03 VGS.....	A.55
CHVS 16.....	E.213	CJ KM.....	A.30	CKAX 03 VGS.....	A.57	CL 9/125 LC2.....	C.85
CHVS 24.....	E.215	CJPW K.....	F.66	CKAXE 03 I.....	A.76	CL 9/125 LC3.....	C.85
CHVW 16.....	E.159	CJPZ T.....	F.65	CKAXE 03 IA.....	A.76	CL 9/125 SC.....	A.38, C.84
CHVW 24.....	E.161	CJPZ Y.....	F.64	CKAXR 03 I.....	I.16	CL 125 LC2.....	C.85
CHVW 32.....	E.167	CJST.....	F.64*	CKAXR 03 IA.....	I.16	CL 125 LC3.....	C.85
CHVW 32 G.....	E.166	CJZ 8 IA4.....	A.42	CKAXS 03 AP.....	A.84	CL 125 SC.....	A.38, C.84
CHVW 48 L.....	E.169	CJZ 8 IA4N.....	A.42	CKAXS 03 I.....	A.84	CLC1.....	F.68*
CIES B.....	F.55	CJZ 8 IN.....	A.40	CKAXS 03 IA.....	A.84	CLC4.....	F.68*
CIF 2.4.....	D.14	CJZA 8 I.....	A.40	CKAXS 03 IA4.....	A.85	CLC 06 LG.....	E.90
CIF 2.4 A.....	D.14	CJZA 8 IA4.....	A.42	CKAXS 03 IAP.....	A.84	CLC 10 G.....	E.94
CIF2D 0.2.....	F.17	CJZAX 8 IA4.....	A.42	CKAXS 03 VG.....	A.88	CLC 10 LG.....	E.92
CIF2D 0.3.....	F.17	CJZAXX 8 IA4.....	A.42	CKAXW 03 AP.....	A.73	CLC 16 G.....	E.98
CIF2D 0.5.....	F.17	CK 03 C.....	A.50	CKAXW 03 I.....	A.72	CLC 16 LG.....	E.96
CIF2D 0.7.....	F.17	CK 03 CA.....	A.50	CKAXW 03 IA.....	A.72	CLC 24 G.....	E.102
CIF 5 2.4.....	D.14	CK 03 CAN.....	A.50	CKAXW 03 IA4.....	A.72	CLC 24 LG.....	E.100
CIFA 0.2.....	A.12, C.50*, F.17	CK 03 CAS.....	A.50	CKAXW 03 IAP.....	A.73	CLCES.....	F.59
CIFA 0.3.....	A.12, C.50*, F.17	CK 03 CN.....	A.50	CKAXW 03 VG.....	A.74	CLCS 06 LG.....	E.208
CIFA 0.5.....	A.12, C.50*, F.17	CK 03 CS.....	A.50	CKAXX 03 IA4.....	A.63	CLCS 10 G.....	E.210
CIFA 0.7.....	C.50, F.17	CK 03 CX.....	A.48	CKAXXS 03IA4.....	A.85	CLCS 16 G.....	E.212
CIFD 0.2.....	A.12, C.50*, F.17	CK 03 CXA.....	A.48	CKAXXW 03IA4.....	A.73	CLCS 24 G.....	E.214
CIFD 0.3.....	A.12, C.50*, F.17	CK 03 CXAN.....	A.48	CKF 03.....	A.16	CLDL.....	F.68
CIFD 0.5.....	A.12, C.50*, F.17	CK 03 CXN.....	A.48	CKF 03 N.....	A.16	CLDL DD.....	F.70
CIFD 0.7.....	C.50, F.17	CK 03 I.....	A.46*	CKF 03 RY.....	I.4	CLES.....	F.58*
CIFJD 0.2.....	F.17	CK 03 IA.....	A.46	CKF 04.....	A.16	CLF DD.....	F.21
CIFJD 0.3.....	F.17	CK 03 IA4.....	A.46	CKF 04 N.....	A.16	CLI 06 L.....	E.90
CIFJD 0.5.....	F.17	CK 03 IA4N.....	A.46	CKF 04 RY.....	I.4	CLI 06 LS.....	E.90
CIFJD 0.7.....	F.17	CK 03 IAN.....	A.46	CKFD 03.....	A.18	CLI 10.....	E.94
CIF Q4/2 2.4.....	D.10	CK 03 IAPNS.....	A.46	CKFD 04.....	A.18	CLI 10 L.....	E.92
CIF Q05 2.4.....	D.4	CK 03 IAPS.....	A.46	CKG 03 C.....	A.52	CLI 10 LS.....	E.92
CIF Q07 2.4.....	D.4	CK 03 IN.....	A.46*	CKG 03 CN.....	A.52	CLI 16.....	E.98
CIF Q08 1.6.....	D.10	CK 03 VANS.....	A.49	CKG 03 V.....	A.52	CLI 16 L.....	E.96
CIF Q12 2.4.....	D.6	CK 03 VAS.....	A.49	CKG 03 VA.....	A.52	CLI 16 LS.....	E.96
CIF X17 2.4.....	D.14	CK 03 VGNS.....	A.48	CKG 03 VAN.....	A.52	CLI 24.....	E.102
CIM2D 0.2.....	F.17	CK 03 VGS.....	A.48	CKG 03 VN.....	A.52	CLI 24 L.....	E.100
CIM2D 0.3.....	F.17	CK 03 VNS.....	A.49	CKH 03 C.....	A.96	CLI 24 LS.....	E.100
CIM2D 0.5.....	F.17	CK 03 VS.....	A.49	CKH 03 CA.....	A.96	CLIS 06 L.....	E.208
CIM2D 0.7.....	F.17	CKA 03 APS.....	A.58	CKH 03 CAS.....	A.96	CLIS 10.....	E.210
CIMA 0.2.....	A.12, C.50*, F.17	CKA 03 C.....	A.64	CKH 03 CS.....	A.96	CLIS 16.....	E.212
CIMA 0.3.....	A.12, C.50*, F.17	CKA 03 CA.....	A.64	CKH 03 CX.....	A.95	CLIS 24.....	E.214
CIMA 0.5.....	A.12, C.50*, F.17	CKA 03 CAS.....	A.64	CKH 03 CXA.....	A.95	CLK 04 SCF.....	A.38
CIMA 0.7.....	C.50, F.17	CKA 03 CS.....	A.64	CKH 03 I.....	A.94	CLK 04 SCF-H.....	A.38
CIMD 0.2.....	A.12, C.50*, F.17	CKA 03 I.....	A.58*	CKH 03 IA.....	A.94	CLK 04 SCM.....	A.38
CIMD 0.3.....	A.12, C.50*, F.17	CKA 03 IA.....	A.58	CKH 03 IA4.....	A.94	CLM DD.....	F.21
CIMD 0.5.....	A.12, C.50*, F.17	CKA 03 IA4.....	A.63	CKM 03.....	A.16	CL POF SC.....	A.38, C.84
CIMD 0.7.....	C.50, F.17	CKA 03 IAPS.....	A.58	CKM 03 N.....	A.16	CLPZ R.....	F.68*
CIMJD 0.2.....	F.17	CKA 03 ILS.....	A.58*	CKM 03 RY.....	I.4	CLSG.....	F.68*
CIMJD 0.3.....	F.17	CKA 03 ILSA.....	A.58	CKM 03 T1.....	G.19	CLSP.....	F.68*
CIMJD 0.5.....	F.17	CKA 03 VAS.....	A.64	CKM 03 T3.....	G.19	CLTE.....	F.68*
CIMJD 0.7.....	F.17	CKA 03 VGS.....	A.59	CKM 04.....	A.16	CMCEF 03.....	B.144
CIO 16.36.....	E.69	CKA 03 VS.....	A.64	CKM 04 N.....	A.16	CMCEF 06.....	B.145*
CIO 24.36.....	E.77	CKAG 03 C.....	A.66	CKM 04 RY.....	I.4	CMCEF 06 N.....	B.147
CIO 24 YX36.....	E.261	CKAG 03 V.....	A.66	CKMD 03.....	A.18	CMCEF 10.....	B.146*
CIPZ D.....	F.44	CKAG 03 VA.....	A.66	CKMD 04.....	A.18	CMCEF 10 N.....	B.148
CIPZP D.....	F.46	CKAS 03 IA4.....	A.85	CKR 65.....	A.67	CMCEM 06.....	B.147
CITP D.....	F.44*	CKAS 03 V.....	A.89	CKRH 65.....	A.97	CMCEM 06 N.....	B.147
CIV 16.29.....	E.69	CKAS 03 VA.....	A.89	CKSHF 03.....	A.19	CMCEM 10.....	B.146*
CIV 24.36.....	E.77	CKAW 03 V.....	A.75	CKSHF 04.....	A.19	CMCEM 10 N.....	B.148
CIV 24 YX36.....	E.261	CKAW 03 VA.....	A.75	CKSHM 03.....	A.19	CMECM 03.....	B.144
CIVES.....	F.55	CKAX 03 APS.....	A.56	CKSHM 04.....	A.19	CMECM 06.....	B.145
CJK 8B IFT.....	A.32	CKAX 03 CX.....	A.57	CKX 03 I.....	A.53	CMPEB.....	F.57
CJK 8FT.....	A.31	CKAX 03 CXA.....	A.57	CKX 03 IA.....	A.53	CMPEB B.....	F.57
CJK 8IFT.....	A.32	CKAX 03 I.....	A.56*	CKX 03 IA4.....	A.53	CMSHF 03.....	B.149
CJK 8IMT.....	A.32	CKAX 03 IA.....	A.56	CKX 03 IAP.....	A.53	CMSHF 06.....	B.150*
CJK 8M.....	A.33	CKAX 03 IA4.....	A.60	CKX 03 IAPS.....	A.53	CMSHF 06 N.....	B.152
CJK 8MT.....	A.31	CKAX 03 IAPS.....	A.56	CKX 03 IN.....	A.53	CMSHF 10.....	B.151*

* These items are also shown in various sections throughout the catalogue

CMSHF 10 N.....	B.153	CPPZE C US.....	F.28	CQF 21.....	A.12, H.8	CR 15 AD2.....	G.27
CMSHM 03.....	B.149	CPPZEH C AU.....	F.29	CQM 04/2.....	B.7	CR 16 AT.....	G.24
CMSHM 06.....	B.150*	CPPZEH C EU.....	F.29	CQM 04/2B.....	B.8	CR 16 BPE.....	E.236*
CMSHM 06 N.....	B.152	CPPZEH C UK.....	F.29	CQM 04/2E.....	B.6	CR 16 DF.....	C.97, G.26, H.64
CMSHM 10.....	B.151*	CPPZEH C US.....	F.29	CQM 05.....	A.8	CR 16 FS.....	G.21
CMSHM 10 N.....	B.153	CPT 24.....	G.48	CQM 07.....	A.10	CR 16 GTPC.....	E.249
CNEF 06 RY.....	I.5	CPYF 06.....	B.114*	CQM 08.....	B.11	CR 16 SC.....	G.25
CNEF 06 T.....	B.38	CPYF 06 N.....	B.115	CQM 08E.....	B.9	CR 16 SS.....	G.20
CNEF 06 TX.....	B.38	CPYM 06.....	B.114*	CQM 12.....	A.11	CR 16 SSD.....	G.20
CNEF 10 RY.....	I.6	CPYM 06 N.....	B.115	CQM 12 CIF.....	D.6	CR 16 ST.....	G.22
CNEF 10 T.....	B.39	CQ4F 02.....	A.5	CQM 17.....	B.12	CR 16 STA.....	G.23
CNEF 10 TX.....	B.39	CQ4F 02 H.....	A.4	CQM 21.....	A.12, H.8	CR 20.....	G.12
CNEF 16 RY.....	I.7	CQ4F 03.....	A.6, H.6	CQO 24.....	E.77	CR 20 CX.....	G.12
CNEF 16 T.....	B.40*	CQ4F 03/2.....	A.7	CQS 08 I.....	E.8	CR 20 CX D.....	G.12
CNEF 16 TN.....	B.42	CQ4M 02.....	A.5	CQS 08 IA.....	E.8	CR 20 D.....	G.12
CNEF 16 TX.....	B.40*	CQ4M 02 H.....	A.4	CQS 08 IAP.....	E.8	CR 21.21 GMH.....	A.97
CNEF 16 TXN.....	B.42	CQ4M 03.....	A.6, H.6	CQS 08 V.....	E.9	CR 21.21 GMS.....	A.90
CNEF 24 RY.....	I.8*	CQ4M 03/2.....	A.7	CQS 08 VA.....	E.9	CR 24 AT.....	G.24
CNEF 24 RYN.....	I.9	CQ 08 C.....	E.7	CQS 08 VG.....	E.8	CR 24 ATD.....	G.24
CNEF 24 T.....	B.41*	CQ 08 CA.....	E.7	CQV 24.....	E.77	CR 24 BPE.....	E.236*
CNEF 24 TN.....	B.43	CQ 08 I.....	E.6	CQYF 05.....	A.9	CR 24 DF.....	C.97, G.26, H.64
CNEF 24 TX.....	B.41*	CQ 08 IA.....	E.6	CQYF 08E.....	B.10	CR 24 FS.....	G.21
CNEF 24 TXN.....	B.43	CQ 08 IAP.....	E.6	CQYM 05.....	A.9	CR 24 GTPC.....	E.249
CNEM 06 RY.....	I.5	CQ 08 V.....	E.7	CQYM 08E.....	B.10	CR 24 SC.....	G.25
CNEM 06 T.....	B.38	CQ 08 VA.....	E.7	CR 03 C11B.....	A.68	CR 24 SCA.....	G.25
CNEM 06 TX.....	B.38	CQ 08 VG.....	E.6	CR 03 C11G.....	A.68	CR 24 SS.....	G.20
CNEM 10 RY.....	I.6	CQA 08 I.....	E.10	CR 03 C11N.....	A.68	CR 24 SSD.....	G.20
CNEM 10 T.....	B.39	CQAM 12 T1.....	G.19	CR 03 C11R.....	A.68	CR 24 ST.....	G.22
CNEM 10 TX.....	B.39	CQEEF 40.....	B.78	CR 03 C20B.....	A.68	CR 24 STA.....	G.23
CNEM 16 RY.....	I.7	CQEEF 64.....	B.79	CR 03 C20G.....	A.68	CR 25/16.....	E.290
CNEM 16 T.....	B.40*	CQEEM 40.....	B.78	CR 03 C20N.....	A.68	CR 25 AD.....	G.27
CNEM 16 TN.....	B.42	CQEEM 64.....	B.79	CR 03 C20R.....	A.68	CR 25 AD1.....	G.27
CNEM 16 TX.....	B.40*	CQEF 10.....	B.72	CR 03 C25B.....	A.68	CR 25 AD2.....	G.27
CNEM 16 TXN.....	B.42	CQEF 18.....	B.73	CR 03 C25G.....	A.68	CR 26 V.....	G.20*
CNEM 24 RY.....	I.8*	CQEF 32.....	B.74*	CR 03 C25N.....	A.68	CR 37 AD.....	G.27
CNEM 24 RYN.....	I.9	CQEF 32 N.....	B.76	CR 03 C25R.....	A.68	CR 37 AD1.....	G.27
CNEM 24 T.....	B.41*	CQEF 46.....	B.75*	CR 03 CKB.....	A.69	CR 37 AD2.....	G.27
CNEM 24 TN.....	B.43	CQEF 46 N.....	B.77	CR 03 CKG.....	A.69	CR 42 V.....	G.20*
CNEM 24 TX.....	B.41*	CQEM 10.....	B.72	CR 03 CKN.....	A.69	CR 50 AD.....	G.27
CNEM 24 TXN.....	B.43	CQEM 18.....	B.73	CR 03 CKR.....	A.69	CR 50 AD1.....	G.27
COB 03/3 BC.....	E.291	CQEM 32.....	B.74*	CR 03 GKIVGR.....	A.90	CR 50 AD2.....	G.27
COB 06 BC.....	E.287	CQEM 32 N.....	B.76	CR 05 CA.....	G.20*	CR 72.....	G.14
COB 06 CMS.....	E.289	CQEM 46.....	B.75*	CR 06 AT.....	G.24	CR 72 CX.....	G.14
COB 10 BC.....	E.287	CQEM 46 N.....	B.77	CR 06 BPE.....	E.236*	CR 72 CX D.....	G.14
COB 10 CMS.....	E.289	CQES.....	F.55	CR 06 DF.....	C.97, G.26, H.64	CR 72 D.....	G.14
COB 16 BC.....	E.287	CQEYF 10.....	B.82	CR 06 FS.....	G.21	CRAD.....	G.32
COB 16 CMS.....	E.289	CQEYF 18.....	B.83	CR 06 GTPC.....	E.249	CRAS.....	G.32
COB 24 BC.....	E.287	CQEYF 32.....	B.84*	CR 06 SC.....	G.25	CR BDE.....	G.16
COB 24 CMS.....	E.289	CQEYF 32 N.....	B.86	CR 06 ST.....	G.22	CR BDSH3A.....	G.18
COB L.....	E.292	CQEYF 46.....	B.85*	CR 06 STA.....	G.23	CR BDSH3G.....	G.18
COB TCQ.....	E.286	CQEYF 46 N.....	B.87	CR 08 EMC.....	E.9	CR BDSH6A.....	G.18
COB TSF.....	E.288	CQEYM 10.....	B.82	CR 09 AD.....	G.27	CR BDSH6G.....	G.18
COB TSFS.....	E.288	CQEYM 18.....	B.83	CR 09 AD1.....	G.27	CR BDSH9A.....	G.18
COPZ.....	F.67	CQEYM 32.....	B.84*	CR 09 AD2.....	G.27	CR BDSH9G.....	G.18
COST.....	F.67	CQEYM 32 N.....	B.86	CR 10 AT.....	G.24	CR BDSH14A.....	G.18
CPF 06.....	B.112*	CQEYM 46.....	B.85*	CR 10 BPE.....	E.236*	CR BDSH14G.....	G.18
CPF 06 N.....	B.113	CQEYM 46 N.....	B.87	CR 10 CA.....	G.20*	CRBF.....	G.32
CPF 06 RY.....	I.10	CQF 04/2.....	B.7	CR 10 DF.....	C.97, G.26, H.64	CR BLC622.....	G.44
CPF 06 X.....	B.112	CQF 04/2B.....	B.8	CR 10 FS.....	G.21	CRBM.....	G.32
CPM 06.....	B.112*	CQF 04/2E.....	B.6	CR 10 GTPC.....	E.249	CR BST.....	G.17
CPM 06 N.....	B.113	CQF 05.....	A.8	CR 10 MO.....	E.131	CR CDS.....	G.10
CPM 06 RY.....	I.10	CQF 07.....	A.10	CR 10 SC.....	G.25	CR CKT.....	A.67
CPM 06 X.....	B.112	CQF 08.....	B.11	CR 10 ST.....	G.22	CR CLK.....	G.43
CPPZ C.....	F.26	CQF 08E.....	B.9	CR 10 STA.....	G.23	CR CP.....	G.3
CPPZE C AU.....	F.28	CQF 12.....	A.11	CR 15/16.....	E.290	CR CPC.....	G.9
CPPZE C EU.....	F.28	CQF 12 CIF.....	D.6	CR 15 AD.....	G.27	CR CPQ.....	G.3
CPPZE C UK.....	F.28	CQF 17.....	B.12	CR 15 AD1.....	G.27	CR CX01B.....	C.107

* These items are also shown in various sections throughout the catalogue

CR CX01G.....	C.107	CSHM 06.....	B.52	CTSEM 24 LN.....	B.135	CVFV 10 G21.....	E.131
CR CX01N.....	C.107	CSHM 10.....	B.53	CTSEM 24 R.....	B.133*	CVFV 10 G29.....	E.131
CR CX01R.....	C.107	CSHM 16.....	B.54*	CTSEM 24 RN.....	B.135	CVFV 10 LG21.....	E.131
CRD.....	G.16	CSHM 16 N.....	B.56	CTSF 40 L.....	B.140	CVFV 10 LG29.....	E.131
CRF.....	G.13*	CSHM 24.....	B.55*	CTSF 40 R.....	B.140	CVFV 16 G21.....	E.133
CRF CX.....	G.13*	CSHM 24 N.....	B.57	CTSF 64 L.....	B.141	CVFV 16 G29.....	E.133
CRF CX D.....	G.13*	CSHMT 10.....	B.66	CTSF 64 R.....	B.141	CVFV 16 LG21.....	E.133
CRF D.....	G.13*	CSHMT 16.....	B.67	CTSM 40 L.....	B.140	CVFV 16 LG29.....	E.133
CR GND.....	C.62	CSHMT 24.....	B.68	CTSM 40 R.....	B.140	CVFV 24 G21.....	E.135
CRH 24.....	G.30	CSSF 06.....	B.118	CTSM 64 L.....	B.141	CVFV 24 G29.....	E.135
CRIC M3.....	G.33	CSSF 10.....	B.119	CTSM 64 R.....	B.141	CVFV 24 LG21.....	E.135
CR K03.....	G.2	CSSF 16.....	B.120*	CUK 2FT.....	A.36	CVFV 24 LG29.....	E.135
CR K04G.....	G.2	CSSF 16 N.....	B.122	CUK 3FT.....	A.36	CVI 06 LP.....	E.128
CR K04R.....	G.2	CSSF 24.....	B.121*	CVAP 06 LP.....	E.128	CVI 06 LS.....	E.128
CR KC.....	G.11	CSSF 24 N.....	B.123	CVAP 06 LP2.....	E.128	CVI 06 LSP.....	E.128
CRM.....	G.13*	CSSM 06.....	B.118	CVAP 06 LP29.....	E.128	CVI 10 L.....	E.130
CR MBT.....	A.80	CSSM 10.....	B.119	CVAP 06LP229.....	E.128	CVI 10 LA.....	E.131
CRM CX.....	G.13*	CSSM 16.....	B.120*	CVAP 06 LS.....	E.128	CVI 10 LP.....	E.130
CRM CX D.....	G.13*	CSSM 16 N.....	B.122	CVAP 06 LS2.....	E.128	CVI 10 LS.....	E.130
CRM D.....	G.13*	CSSM 24.....	B.121*	CVAP 06 LS29.....	E.128	CVI 10 LSP.....	E.130
CRN 1.....	E.77	CSSM 24 N.....	B.123	CVAP 06LS229.....	E.128	CVI 16 L.....	E.132
CRN 2.....	E.77	CT APE.....	G.32	CVAP 06LSP21.....	E.128	CVI 16 LP.....	E.132
CRN 3.....	E.77	CTF 06 L.....	B.126	CVAP 06LSP29.....	E.128	CVI 16 LS.....	E.132
CRN P.....	E.77	CTF 06 R.....	B.126	CVAP 10 L.....	E.131	CVI 16 LSP.....	E.132
CRPZ.....	G.16	CTF 10 L.....	B.127	CVAP 10 L2.....	E.131	CVI 24 L.....	E.134
CR Q02.....	G.5	CTF 10 R.....	B.127	CVAP 10 L29.....	E.131	CVI 24 LP.....	E.134
CR Q03.....	G.6	CTF 16 L.....	B.128	CVAP 10 L229.....	E.131	CVI 24 LS.....	E.134
CR Q03/2.....	G.7	CTF 16 R.....	B.128	CVAP 10 LP.....	E.130	CVI 24 LSP.....	E.134
CR Q08E.....	G.8	CTF 24 L.....	B.129	CVAP 10 LP2.....	E.130	CVIR 06 L.....	I.18
CR Q12.....	G.3	CTF 24 R.....	B.129	CVAP 10 LP29.....	E.130	CVIR 10.....	I.20
CRQ 16.....	E.9	CTF 40 L.....	B.138	CVAP 10LP229.....	E.130	CVIR 16.....	I.22
CRQ 16-1.....	E.9	CTF 40 R.....	B.138	CVAP 10 LS.....	E.130	CVIR 24.....	I.24
CRQ 16-2.....	E.9	CTF 64 L.....	B.139	CVAP 10 LS2.....	E.130	CVP 06 LP.....	E.128
CRQ 21.....	E.9	CTF 64 R.....	B.139	CVAP 10 LS29.....	E.130	CVP 06 LP2.....	E.128
CRQ 21-1.....	E.9	CTM 06 L.....	B.126	CVAP 10LS229.....	E.130	CVP 06 LS.....	E.128
CRQ 21-2.....	E.9	CTM 06 R.....	B.126	CVAP 10LSP21.....	E.130	CVP 06 LS2.....	E.128
CRQ 21-3.....	E.9	CTM 10 L.....	B.127	CVAP 10LSP29.....	E.130	CVP 06 LSP16.....	E.128
CR QF07.....	G.4	CTM 10 R.....	B.127	CVAP 16 L.....	E.133	CVP 10 L.....	E.131
CR QM07.....	G.4	CTM 16 L.....	B.128	CVAP 16 L2.....	E.133	CVP 10 L2.....	E.131
CR SP.....	G.20*	CTM 16 R.....	B.128	CVAP 16 L29.....	E.133	CVP 10 LP.....	E.130
CR VATG.....	G.33	CTM 24 L.....	B.129	CVAP 16 L229.....	E.133	CVP 10 LP2.....	E.130
CR VDTG.....	G.33	CTM 24 R.....	B.129	CVAP 16 LP.....	E.132	CVP 10 LS.....	E.130
CR VGM4.....	C.96, H.63	CTM 40 L.....	B.138	CVAP 16 LP2.....	E.132	CVP 10 LS2.....	E.130
CR VNTG.....	G.33	CTM 40 R.....	B.138	CVAP 16 LP29.....	E.132	CVP 10 LSP16.....	E.130
CR VPTG.....	G.33	CTM 64 L.....	B.139	CVAP 16LP229.....	E.132	CVP 16 L.....	E.133
CR YLK24.....	G.44	CTM 64 R.....	B.139	CVAP 16 LS.....	E.132	CVP 16 L2.....	E.133
CR YLK24 SL.....	G.44	CTSEF 06 L.....	B.130	CVAP 16 LS2.....	E.132	CVP 16 LP.....	E.132*
CRZ 06.....	G.30	CTSEF 06 R.....	B.130	CVAP 16 LS29.....	E.132	CVP 16 LP2.....	E.132*
CRZ 10.....	G.30	CTSEF 10 L.....	B.131	CVAP 16LS229.....	E.132	CVP 16 LS.....	E.132*
CRZ 16.....	G.30	CTSEF 10 R.....	B.131	CVAP 16LSP21.....	E.132	CVP 16 LS2.....	E.132*
CRZ 24.....	G.30	CTSEF 16 L.....	B.132*	CVAP 16LSP29.....	E.132	CVP 16 LSP21.....	E.132
CSAHF 10.....	B.24	CTSEF 16 LN.....	B.134	CVAP 24 L.....	E.135	CVP 24 L.....	E.135
CSAHF 16.....	B.25*	CTSEF 16 R.....	B.132*	CVAP 24 L2.....	E.135	CVP 24 L2.....	E.135
CSAHF 16 N.....	B.26	CTSEF 16 RN.....	B.134	CVAP 24 L29.....	E.135	CVP 24 LSP21.....	E.134
CSAHM 10.....	B.24	CTSEF 24 L.....	B.133*	CVAP 24 L229.....	E.135	CVV 06 LG.....	E.129
CSAHM 16.....	B.25*	CTSEF 24 LN.....	B.135	CVAP 24 LP.....	E.134	CVV 10 G.....	E.131
CSAHM 16 N.....	B.26	CTSEF 24 R.....	B.133*	CVAP 24 LP2.....	E.134	CVV 10 LG.....	E.131
CSHES.....	F.61	CTSEF 24 RN.....	B.135	CVAP 24 LP29.....	E.134	CVV 16 G.....	E.133
CSHF 06.....	B.52	CTSEM 06 L.....	B.130	CVAP 24LP229.....	E.134	CVV 16 LG.....	E.133
CSHF 10.....	B.53	CTSEM 06 R.....	B.130	CVAP 24 LS.....	E.134	CVV 24 G.....	E.135
CSHF 16.....	B.54*	CTSEM 10 L.....	B.131	CVAP 24 LS2.....	E.134	CVV 24 LG.....	E.135
CSHF 16 N.....	B.56	CTSEM 10 R.....	B.131	CVAP 24 LS29.....	E.134	CW 0.5 J2M4E.....	C.76
CSHF 24.....	B.55*	CTSEM 16 L.....	B.132*	CVAP 24LS229.....	E.134	CW 0.5 J2M8.....	C.76
CSHF 24 N.....	B.57	CTSEM 16 LN.....	B.134	CVAP 24LSP21.....	E.134	CW 0.5 JM4/2.....	C.76
CSHF 24 R.....	B.66	CTSEM 16 R.....	B.132*	CVAP 24LSP29.....	E.134	CW 0.5 JM4E.....	C.76
CSHFT 10.....	B.67	CTSEM 16 RN.....	B.134	CVFV 06 LG21.....	E.129	CW 0.5 JM8.....	C.76
CSHFT 16.....	B.67	CTSEM 24 L.....	B.133*	CVFV 06 LG29.....	E.129	CW 1 J2M87.....	A.34, C.73
CSHFT 24.....	B.68						

* These items are also shown in various sections throughout the catalogue

CW 1 LC9.....	C.85	CWC J6 10M.....	A.34	CX 01B 30PEM.....	C.13	CX 3.0 MPM.....	C.91, H.59
CW 1 LC50.....	C.85	CWC J6 15M.....	A.34	CX 01 BCF.....	C.63	CX 3.0 MPQF.....	C.91, H.59
CW 1 LC62.....	C.85	CWH J6 0.5M.....	A.35	CX 01 BCM.....	C.63	CX 3.0 MPQM.....	C.91, H.59
CW 1 SC9.....	A.38, C.84	CWH J6 0.5MA.....	A.35	CX 01 BF.....	C.64	CX 3.0 MPQV.....	C.91, H.59
CW 1 SC50.....	A.38, C.84	CWH J6 0.25M.....	A.35	CX 01 BM.....	C.64	CX 3.0 MPV.....	C.91, H.59
CW 1 SC62.....	A.38, C.84	CWH J6 1M.....	A.35	CX 01 GF.....	C.21	CX 3.0 PF.....	C.89
CW 2 J2M4E.....	C.76	CWH J6 1MA.....	A.35	CX 01 GM.....	C.21	CX 3.0 PM.....	C.89
CW 2 J2M8.....	C.76	CWH J6 2M.....	A.35	CX 01 GPEF.....	C.26	CX 3.0 VC.....	C.89
CW 2 J2M87.....	A.34, C.73	CWH J6 2MA.....	A.35	CX 01 GPEM.....	C.26	CX 03 4BF.....	C.36, H.42
CW 2 JM4/2.....	C.76	CWH J6 3M.....	A.35	CX 01 J8AIF.....	C.71	CX 03 4BM.....	C.36, H.42
CW 2 JM4E.....	C.76	CWH J6 3MA.....	A.35	CX 01 J8BIF.....	C.71	CX 03 4F.....	C.37, H.43
CW 2 JM8.....	C.76	CWH J6 5M.....	A.35	CX 01 J8F.....	C.70	CX 03 4M.....	C.37, H.43
CW 2 LC9.....	C.85	CWH J6 5MA.....	A.35	CX 01 J8IM.....	C.71	CX 3/4 XDF.....	C.35, H.41
CW 2 LC50.....	C.85	CWH J6 7.5M.....	A.35	CX 01 J8M.....	C.70	CX 3/4 XDM.....	C.35, H.41
CW 2 LC62.....	C.85	CWH J6 7.5MA.....	A.35	CX 01 J8PIF.....	C.71	CX 03 4YF.....	C.38
CW 2 MIAF.....	C.78	CWH J6 10M.....	A.35	CX 01 J8UM.....	C.72	CX 03 4YM.....	C.38
CW 2 MIAM.....	C.78	CWH J6 10MA.....	A.35	CX 01 JF.....	C.74	CX 03 MP.....	C.90, H.58
CW 2 SC9.....	A.38, C.84	CWH J6 15M.....	A.35	CX 01 JM.....	C.74	CX 03 P.....	C.88
CW 2 SC50.....	A.38, C.84	CWH JE 0.5M.....	A.35	CX 01 JIF.....	C.78	CX 03 PDF.....	C.99, H.66
CW 2 SC62.....	A.38, C.84	CWH JE 1M.....	A.35	CX 01 MIM.....	C.78	CX 03 PDM.....	C.99, H.66
CW 2 UAM.....	A.36, C.77	CWH JE 2M.....	A.35	CX 01 PEF.....	C.27	CX 03 TF.....	C.95
CW 3 J2M87.....	A.34, C.73	CWH JE 3M.....	A.35	CX 01 PEM.....	C.27	CX 03 TM.....	C.95
CW 3 LC9.....	C.85	CWH JE 5M.....	A.35	CX 01 T.....	C.94	CX 4.0 MPAF.....	C.91, H.59
CW 3 LC50.....	C.85	CWH JE 7.5M.....	A.35	CX 01 TPF.....	C.103	CX 4.0 MPAM.....	C.91, H.59
CW 3 LC62.....	C.85	CWH JE 10M.....	A.35	CX 01 TPM.....	C.103	CX 4.0 MPAV.....	C.91, H.59
CW 3 SC9.....	A.38, C.84	CWH JE 15M.....	A.35	CX 01 UF.....	C.77	CX 4.0 MPF.....	C.91, H.59
CW 3 SC50.....	A.38, C.84	CW J5 1M.....	A.34	CX 01 UM.....	C.77	CX 4.0 MPM.....	C.91, H.59
CW 3 SC62.....	A.38, C.84	CW J5 2M.....	A.34	CX 01 YAF.....	C.18	CX 4.0 MPQF.....	C.91, H.59
CW 5 J2M4E.....	C.76	CW J5 3M.....	A.34	CX 01 YAM.....	C.18	CX 4.0 MPQM.....	C.91, H.59
CW 5 J2M8.....	C.76	CW J5 5M.....	A.34	CX 01 YF.....	C.16	CX 4.0 MPQV.....	C.91, H.59
CW 5 J2M87.....	A.34, C.73	CW J5 7.5M.....	A.34	CX 01 YM.....	C.16	CX 4.0 MPV.....	C.91, H.59
CW 5 JM4/2.....	C.76	CW J5 10M.....	A.34	CX 01 YPEAF.....	C.19	CX 4.0 PF.....	C.89
CW 5 JM4E.....	C.76	CW J5 15M.....	A.34	CX 01 YPEAM.....	C.19	CX 4.0 PM.....	C.89
CW 5 JM8.....	C.76	CWK 2 J2M8.....	A.40	CX 01 YPEF.....	C.17	CX 4.0 VC.....	C.89
CW 5 LC9.....	C.85	CWK 5 J2M8.....	A.40	CX 01 YPEM.....	C.17	CX 4/2 JF.....	A.30, C.74*
CW 5 LC50.....	C.85	CWK 10 J2M8.....	A.40	CX 02 4AM.....	C.30	CX 4/2 JM.....	A.30, C.74*
CW 5 LC62.....	C.85	CWKA 2 J2M8.....	A.40	CX 02 4BF.....	C.30	CX 04 BF.....	C.64
CW 5 SC9.....	A.38, C.84	CWKA 5 J2M8.....	A.40	CX 02 4BM.....	C.30	CX 04 BM.....	C.64
CW 5 SC50.....	A.38, C.84	CWKA 10 J2M8.....	A.40	CX 02 4F.....	C.31, H.39	CX 4E JM.....	A.30, C.74*
CW 5 SC62.....	A.38, C.84	CW XJ0.5M.....	A.34	CX 02 4HF.....	C.52	CX 4 JF.....	A.30, C.74*
CW 5 UAM.....	A.36, C.77	CW XJ1M.....	A.34	CX 02 4HM.....	C.52	CX 4 JM.....	A.30, C.74*
CW 7.5J2M87.....	A.34, C.73	CW XJ2M.....	A.34	CX 02 4M.....	C.31, H.39	CX 04 LF.....	C.81
CW 10 J2M4E.....	C.76	CW XJ3M.....	A.34	CX 02 4YF.....	C.32	CX 04 LM.....	C.81
CW 10 J2M8.....	C.76	CW XJ5M.....	A.34	CX 02 4YM.....	C.32	CX 04 PDF.....	C.100, H.67
CW 10 J2M87.....	A.34, C.73	CW XJ7.5M.....	A.34	CX 02 7F.....	C.22, H.38	CX 04 PDM.....	C.100, H.67
CW 10 JM4/2.....	C.76	CW XJ10M.....	A.34	CX 02 7M.....	C.22, H.38	CX 04 RF.....	C.80
CW 10 JM4E.....	C.76	CX 1/2 BDF.....	A.37	CX 02 BF.....	C.62	CX 04 RM.....	C.80
CW 10 JM8.....	C.76	CX 1/2 BDM.....	A.37	CX 02 BM.....	C.62	CX 04 SCF.....	C.84
CW 10 LC9.....	C.85	CX 1.6 PF.....	C.89	CX 02 CHF.....	C.54	CX 04 SCF-H.....	C.84
CW 10 LC50.....	C.85	CX 1.6 PM.....	C.89	CX 02 CHM.....	C.54	CX 04 SCM.....	C.84
CW 10 LC62.....	C.85	CX 1.6 VC.....	C.89	CX 02 GF.....	C.20	CX 04 TF.....	C.95
CW 10 SC9.....	A.38, C.84	CX 01 9VF.....	C.79	CX 02 GM.....	C.20	CX 04 TM.....	C.95
CW 10 SC50.....	A.38, C.84	CX 01 9VF2.....	C.79	CX 02 HF.....	C.53	CX 04 XF.....	C.33, H.40
CW 10 SC62.....	A.38, C.84	CX 01 9VM.....	C.79	CX 02 HM.....	C.53	CX 04 XM.....	C.33, H.40
CW 15 J2M87.....	A.34, C.73	CX 01 9VM2.....	C.79	CX 02 JF.....	C.75	CX 04 XYF.....	C.34
CWC J5 1M.....	A.34	CX 01 9VTF.....	C.79	CX 02 JM.....	C.75	CX 04 XYM.....	C.34
CWC J5 2M.....	A.34	CX 01 30AF.....	C.14	CX 02 MPBF.....	C.92, H.60	CX 5/7 CA.....	C.61, H.56
CWC J5 3M.....	A.34	CX 01 30AM.....	C.14	CX 02 MPBM.....	C.92, H.60	CX 05 SHF.....	C.45
CWC J5 5M.....	A.34	CX 01 30F.....	C.12	CX 02 P.....	C.88	CX 05 SHM.....	C.45
CWC J5 7.5M.....	A.34	CX 01 30M.....	C.12	CX 02 PDF.....	C.98, H.65	CX 6.0 MPAF.....	C.91, H.59
CWC J5 10M.....	A.34	CX 01 30PEAF.....	C.15	CX 02 PDM.....	C.98, H.65	CX 6.0 MPAM.....	C.91, H.59
CWC J5 15M.....	A.34	CX 01 30PEAM.....	C.15	CX 02 TF.....	C.95	CX 6.0 MPAV.....	C.91, H.59
CWC J6 1M.....	A.34	CX 01 30PEF.....	C.13	CX 02 TM.....	C.95	CX 6.0 MPF.....	C.91, H.59
CWC J6 2M.....	A.34	CX 01 30PEM.....	C.13	CX 3.0 MPAF.....	C.91, H.59	CX 6.0 MPM.....	C.91, H.59
CWC J6 3M.....	A.34	CX 01B 30F.....	C.12	CX 3.0 MPAM.....	C.91, H.59	CX 6.0 MPQF.....	C.91, H.59
CWC J6 5M.....	A.34	CX 01B 30M.....	C.12	CX 3.0 MPAV.....	C.91, H.59	CX 6.0 MPQM.....	C.91, H.59
CWC J6 7.5M.....	A.34	CX 01B 30PEF.....	C.13	CX 3.0 MPF.....	C.91, H.59	CX 6.0 MPQV.....	C.91, H.59

* These items are also shown in various sections throughout the catalogue

CX 6.0 MPV.....	C.91, H.59	CX 10 MPM.....	C.93, H.61	CXCM 4/2.....	B.160	CYFA 70.....	C.16*, F.7
CX 6.0 PF.....	C.89	CX 10 MPQF.....	C.93, H.61	CXCM 4/8.....	B.162	CYG 4/2 JF.....	A.41
CX 6.0 PM.....	C.89	CX 10 MPQM.....	C.93, H.61	CXES.....	F.54	CYG 4/2 JFA.....	A.41
CX 6.0 VC.....	C.89	CX 10 MPQV.....	C.93, H.61	CXES-10.....	F.54	CYG 4 JF.....	A.41
CX 6/2 JM.....	A.30, C.74*	CX 10 MPV.....	C.93, H.61	CXF 4/0.....	B.158	CYG 4 JFA.....	A.41
CX 06 CF.....	C.41, H.46	CX 11/14 CA.....	C.61, H.56	CXF 4/0 RY.....	I.11	CYG 06H06.....	G.38
CX 06 CM.....	C.41, H.46	CX 12 DF.....	C.46, H.48	CXF 4/2.....	B.159	CYG 06H06D.....	G.38
CX 06 CYF.....	C.42	CX 12 DM.....	C.46, H.48	CXF 4/2 RY.....	I.12	CYG 06H10.....	G.38
CX 06 CYM.....	C.42	CX 12 DYF.....	C.47	CXF 4/8.....	B.161	CYG 06H10D.....	G.38
CX 06 LCF.....	C.85	CX 12 DYM.....	C.47	CXF 4/8 RY.....	I.13	CYG 06H0606.....	G.39
CX 06 LCM.....	C.85	CX 17 DF.....	C.48, H.49	CXF 6/6.....	B.157	CYG 06H0610.....	G.39
CX 06P CF.....	C.39, H.44	CX 17 DM.....	C.48, H.49	CXF 6/12.....	B.164	CYG 06H1006.....	G.39
CX 06P CM.....	C.39, H.44	CX 20 CF.....	C.40, H.45	CXF 6/36.....	B.169	CYG 06H1010.....	G.39
CX 06 PDF.....	C.101, H.68	CX 20 CM.....	C.40, H.45	CXF 8/0.....	B.156	CYG 8/2 JF.....	A.41
CX 06 PDM.....	C.101, H.68	CX 20S IF.....	C.60	CXF 8/24.....	B.170	CYG 8/2 JFA.....	A.41
CX 06 TF.....	C.95	CX 20S IGF.....	C.60	CXF 9/42.....	B.168	CYG 8 JF.....	A.41
CX 06 TM.....	C.95	CX 20S IGM.....	C.60	CXF 12/2.....	B.163	CYG 8 JFA.....	A.41
CX 7/10 CA.....	C.61, H.56	CX 20S IM.....	C.60	CXFA 1.5.....	A.4*, B.6*, C.31*, F.10	CYG 9KAXI3.....	G.40
CX7ES.....	F.54	CX 25 IBF.....	C.50, H.51	CXFA 2.5.....	A.4*, B.6*, C.31*, F.10	CYG 16.....	G.37
CX7FA 6.0.....	B.160*, C.22, F.9	CX 25 IBM.....	C.50, H.51	CXFA 4.0.....	A.4*, B.6*, C.31*, F.10	CYMA 16.....	C.16*, F.7
CX7FA 10.....	B.160*, C.22, F.9	CX 30.40CF.....	G.28	CXFA 6.0.....	A.4*, B.6*, C.31*, F.10	CYMA 25.....	C.16*, F.7
CX7FA 16.....	B.160*, C.22, F.9	CX 35.45CF.....	G.28	CXFA 10.....	A.4*, B.8*, C.31*, F.10	CYMA 35.....	C.16*, F.7
CX7FA 16 XF.....	B.160*, C.22	CX 36 IF.....	C.51, H.52	CXFFA.....	D.10	CYMA 50.....	C.16*, F.7
CX7FA 25.....	B.160*, C.22, F.9	CX 36 IM.....	C.51, H.52	CX FM.....	C.102, H.69	CYMA 70.....	C.16*, F.7
CX7MA 6.0.....	B.160*, C.22, F.9	CX 40.50CF.....	G.28	CXM 4/0.....	B.158	CYPZEH LOC.....	F.29
CX7MA 6.0 P.....	C.22, F.9	CX 42 DF.....	C.49, H.50	CXM 4/0 RY.....	I.11	CYPZ LOC.....	F.26*
CX7MA 10.....	B.160*, C.22, F.9	CX 42 DM.....	C.49, H.50	CXM 4/2.....	B.159	CYR 16.3.....	G.36
CX7MA 10 P.....	C.22, F.9	CX 45.55CF.....	G.28	CXM 4/2 RY.....	I.12	CYR 24.4.....	G.36
CX7MA 16.....	B.160*, C.22, F.9	CX 50.60CF.....	G.28	CXM 4/8.....	B.161	CZ7C 15 LG.....	E.26
CX7MA 16 P.....	C.22, F.9	CX 50.60 S.....	G.29	CXM 4/8 RY.....	I.13	CZ7C 25 LG.....	E.27
CX7MA 16 XF.....	B.160*, C.22	CX 50 RF.....	C.80	CXM 6/6.....	B.157	CZ7CE 15 LG.....	E.34
CX7MA 16 XFP.....	C.22, F.9	CX 50 RM.....	C.80	CXM 6/12.....	B.164	CZ7CE 25 LG.....	E.36
CX7MA 25.....	B.160*, C.22	CX 55.65CF.....	G.28	CXM 6/36.....	B.169	CZ7CS 15 LG.....	E.40
CX7MA 25 P.....	C.22, F.9	CX 55.65 S.....	G.29	CXM 8/0.....	B.156	CZ7CS 25 LG.....	E.42
CX7PZEH LOC.....	F.29	CX 60.70CF.....	G.28	CXM 8/24.....	B.170	CZ7CW 15 LG.....	E.28
CX7PZ LOC.....	F.26*	CX 60.70 S.....	G.29	CXM 9/42.....	B.168	CZ7CW 25 LG.....	E.30
CX 8.0 MPF.....	C.93, H.61	CX 65.75CF.....	G.28	CXM 12/2.....	B.163	CZ7I 15 L.....	E.26
CX 8.0 MPM.....	C.93, H.61	CX 65.75 S.....	G.29	CXMA 1.5.....	A.4*, B.6*, C.31*, F.10	CZ7I 15 LS.....	E.26
CX 8.0 MPQF.....	C.93, H.61	CX 70.80CF.....	G.28	CXMA 2.5.....	A.4*, B.6*, C.31*, F.10	CZ7I 25 L.....	E.27
CX 8.0 MPQM.....	C.93, H.61	CX 70.80 S.....	G.29	CXMA 4.0.....	A.4*, B.6*, C.31*, F.10	CZ7I 25 LS.....	E.27
CX 8.0 MPQV.....	C.93, H.61	CX 75.85 S.....	G.29	CXMA 6.0.....	A.4*, B.6*, C.31*, F.10	CZ7IE 15 L.....	E.34
CX 8.0 MPV.....	C.93, H.61	CX 75 RF.....	C.80	CXMA 10.....	A.4*, B.8*, C.31*, F.10	CZ7IE 25 L.....	E.36
CX 8/2 JF.....	A.30, C.74*	CX 75 RM.....	C.80	CXMFA.....	D.10	CZ7IS 15 L.....	E.40
CX 08 BF.....	C.65	CX 76.85CF.....	G.28	CX MLF.....	C.81	CZ7IS 25 L.....	E.42
CX 08 BM.....	C.65	CX 80.90CF.....	G.28	CX MLM.....	C.81	CZ7IW 15 L.....	E.28
CX 08 CF.....	C.43, H.47	CX 80.90 S.....	G.29	CXP 01 C.....	C.106	CZ7IW 25 L.....	E.30
CX 08 CM.....	C.43, H.47	CX 85.95CF.....	G.28	CXP 01 CLG.....	C.106	CZ7PS 15 L2.....	E.40
CX 08 CYF.....	C.44	CX 85.95 S.....	G.29	CXP 02 C.....	C.111	CZ7PS 25 L2.....	E.42
CX 08 CYM.....	C.44	CX 90.100CF.....	G.28	CXP 02 CLG.....	C.111	CZ7PW 15 L2.....	E.28
CX 08 D5F.....	C.58	CX 90.100 S.....	G.29	CX PLF.....	C.81	CZ7PW 25 L2.....	E.30
CX 08 D5F2.....	C.58	CX 95.105 S.....	G.29	CX PLM.....	C.81	CZAC 15 L.....	E.15
CX 08 D5GF.....	C.58	CX 100.110 S.....	G.29	CXPNP.....	F.30	CZAC 25 L.....	E.17
CX 08 D5GF2.....	C.58	CX 105.115 S.....	G.29	CXPNPP.....	F.32	CZAOW 15 L21.....	E.29
CX 08 D5GM.....	C.58	CX 110.120 S.....	G.29	CXPZ D.....	F.30	CZAOW 25 L21.....	E.31
CX 08 D5GM2.....	C.58	CX 115.125 S.....	G.29	CXPZ P.....	F.32	CZAP 25 L.....	E.16
CX 08 D5M.....	C.58	CX 120.130 S.....	G.29	CXPZ TP.....	F.47	CZAP 25 L2.....	E.16
CX 08 D5M2.....	C.58	CX 125.135 S.....	G.29	CXTP 40.....	F.30*	CZAP 25 L21.....	E.16
CX 08 I6F.....	C.59	CX 130.140 S.....	G.29	CYD 35 C.....	F.26*	CZAP 25 L221.....	E.16
CX 08 I6GF.....	C.59	CX 137.150 S.....	G.29	CYD 35EH C.....	F.29	CZAP 25 LS.....	E.16
CX 08 I6GM.....	C.59	CX 140.150 S.....	G.29	CYD 50 C.....	F.26*	CZAP 25 LS2.....	E.16
CX 08 I6M.....	C.59	CXA 01 I.....	C.106	CYD 50EH C.....	F.29	CZAP 25 LS21.....	E.16
CX 8 J6IM.....	A.32, C.71	CXA 02 I.....	C.110	CYD 70 C.....	F.26*	CZAP 25LS221.....	E.16
CX 8 J6M.....	A.31, C.70	CXA 02 IA.....	C.110	CYD 70EH C.....	F.29	CZAP 25LSP16.....	E.16
CX 8 JF.....	A.30, C.74*	CX APE.....	C.103	CYFA 16.....	C.16*, F.7	CZAP 25LSP21.....	E.16
CX 8 JM.....	A.30, C.74*	CX BES.....	F.60	CYFA 25.....	C.16*, F.7	CZAVW 15 L21.....	E.29
CX 10/12 CA.....	C.61, H.56	CXCF 4/2.....	B.160	CYFA 35.....	C.16*, F.7	CZAVW 25 L21.....	E.31
CX 10 MPF.....	C.93, H.61	CXCF 4/8.....	B.162	CYFA 50.....	C.16*, F.7	CZC 15 L.....	E.15

* These items are also shown in various sections throughout the catalogue

CZC 15 LG.....	E.14	JMPAP 06L232.....	E.112	JMPP 06 L220.....	E.112	M7AP 06 L232.....	E.124
CZC 15 SL.....	E.15	JMPAP 06L240.....	E.112	JMPP 10.20.....	E.114	M7AP 06 L240.....	E.124
CZC 25 L.....	E.17	JMPAP 10.25.....	E.114	JMPP 10.220.....	E.114	M7AP 06 LS32.....	E.124
CZC 25 LG.....	E.16	JMPAP 10.32.....	E.114	JMPP 10 L20.....	E.113	M7AP 06 LS40.....	E.124
CZC 25 SL.....	E.17	JMPAP 10.40.....	E.114	JMPP 10 L220.....	E.113	M7AP 06LS232.....	E.124
CZCE 15 L.....	E.35	JMPAP 10.225.....	E.114	JMPP 15 L25.....	E.18	M7AP 06LS240.....	E.124
CZCE 25 L.....	E.37	JMPAP 10.232.....	E.114	JMPP 15 L225.....	E.18	M7AP 10.32.....	E.125
CZCS 15 L.....	E.41	JMPAP 10.240.....	E.114	JMPP 16.25.....	E.116	M7AP 10.40.....	E.125
CZCS 25 L.....	E.43	JMPAP 10 L25.....	E.113	JMPP 16.225.....	E.116	M7AP 10.232.....	E.125
CZCW 15 L.....	E.29*	JMPAP 10 L32.....	E.113	JMPP 16 L25.....	E.115	M7AP 10.240.....	E.125
CZCW 25 L.....	E.31	JMPAP 10 L40.....	E.113	JMPP 16 L225.....	E.115	M7AP 16.32.....	E.126
CZFO 15 L16.....	E.15	JMPAP 10L225.....	E.113	JMPP 16.25.....	E.118	M7AP 16.40.....	E.126
CZFO 15 L21.....	E.15	JMPAP 10L232.....	E.113	JMPP 24.225.....	E.118	M7AP 16.232.....	E.126
CZFO 25 L16.....	E.17	JMPAP 10L240.....	E.113	JMPP 24 L25.....	E.117	M7AP 16.240.....	E.126
CZFO 25 L21.....	E.17	JMPAP 16.25.....	E.116	JMPP 24 L225.....	E.117	M7AP 16 S32.....	E.126
CZFOS 15 L21.....	E.41	JMPAP 16.32.....	E.116	JMPP 25 L25.....	E.19	M7AP 16 S232.....	E.126
CZFOS 25 L21.....	E.43	JMPAP 16.40.....	E.116	JMPP 25 L225.....	E.19	M7AP 24.32.....	E.127
CZFV 15 L16.....	E.15	JMPAP 16.225.....	E.116	JMPV 06 LG25.....	E.112	M7AP 24.40.....	E.127
CZFV 15 L21.....	E.15	JMPAP 16.232.....	E.116	JMPV 10 G25.....	E.114	M7AP 24.232.....	E.127
CZFV 25 L16.....	E.17	JMPAP 16.240.....	E.116	JMPV 10 LG25.....	E.113	M7AP 24.240.....	E.127
CZFV 25 L21.....	E.17	JMPAP 16 L25.....	E.115	JMPV 15 LG20.....	E.18	M7AP 24 S32.....	E.127
CZFV 25 L216.....	E.17	JMPAP 16 L32.....	E.115	JMPV 16 G32.....	E.116	M7AP 24 S232.....	E.127
CZFVS 15 L21.....	E.41	JMPAP 16 L40.....	E.115	JMPV 16 LG32.....	E.115	M7APE 06 L32.....	E.174
CZFVS 25 L21.....	E.43	JMPAP 16L225.....	E.115	JMPV 24 G32.....	E.118	M7APE 06 L40.....	E.174
CZI 15 L.....	E.14	JMPAP 16L232.....	E.115	JMPV 24 LG32.....	E.117	M7APE 06L232.....	E.174
CZI 15 LS.....	E.14	JMPAP 16L240.....	E.115	JMPV 25 LG20.....	E.19	M7APE 06L240.....	E.174
CZI 15 LSP.....	E.14	JMPAP 24.25.....	E.118	JPC 06 LG.....	E.119	M7APE 10.32.....	E.176
CZI 25 L.....	E.16	JMPAP 24.32.....	E.118	JPC 10 G.....	E.119	M7APE 10.40.....	E.176
CZI 25 LS.....	E.16	JMPAP 24.40.....	E.118	JPC 10 LG.....	E.119	M7APE 10.232.....	E.176
CZI 25 LSP.....	E.16	JMPAP 24.225.....	E.118	JPC 15 LG.....	E.18	M7APE 10.240.....	E.176
CZO 15 L.....	E.15	JMPAP 24.232.....	E.118	JPC 16 G.....	E.119	M7APE 16.32.....	E.178
CZO 25 L.....	E.17	JMPAP 24.240.....	E.118	JPC 16 LG.....	E.119	M7APE 16.40.....	E.178
CZOS 15 L.....	E.41	JMPAP 24 L25.....	E.117	JPC 24 G.....	E.119	M7APE 16.232.....	E.178
CZOS 25 L.....	E.43	JMPAP 24 L32.....	E.117	JPC 24 LG.....	E.119	M7APE 16.240.....	E.178
CZOW 15 L.....	E.29	JMPAP 24 L40.....	E.117	JPC 25 LG.....	E.19	M7APE 24.32.....	E.180
CZOW 25 L.....	E.31	JMPAP 24L225.....	E.117	JPI 06 L.....	E.112	M7APE 24.40.....	E.180
CZP 15 L.....	E.14	JMPAP 24L232.....	E.117	JPI 06 LS.....	E.112	M7APE 24.232.....	E.180
CZP 15 L2.....	E.14	JMPAP 24L240.....	E.117	JPI 10.....	E.114	M7APE 24.240.....	E.180
CZP 15 L21.....	E.14	JMPFO 06LG40.....	E.112	JPI 10 L.....	E.113	M7APW 06 L32.....	E.154
CZP 15 L221.....	E.14	JMPFO 10 G40.....	E.113	JPI 10 LS.....	E.113	M7APW 06 L40.....	E.154
CZP 15 LS.....	E.14	JMPFO 10LG40.....	E.113	JPI 15 L.....	E.18	M7APW 06L232.....	E.154
CZP 15 LS2.....	E.14	JMPFO 16 G40.....	E.116	JPI 16.....	E.116	M7APW 06L240.....	E.154
CZP 15 LS21.....	E.14	JMPFO 16LG40.....	E.115	JPI 16 L.....	E.115	M7APW 10.32.....	E.156
CZP 15 LS221.....	E.14	JMPFO 24 G40.....	E.118	JPI 16 LS.....	E.115	M7APW 10.40.....	E.156
CZP 15 LSP16.....	E.14	JMPFO 24LG40.....	E.117	JPI 24.....	E.118	M7APW 10.232.....	E.156
CZP 15 LSP21.....	E.14	JMPFV 06LG25.....	E.112	JPI 24 L.....	E.117	M7APW 10.240.....	E.156
CZV 15 L.....	E.15	JMPFV 06LG32.....	E.112	JPI 24 LS.....	E.117	M7APW 16.32.....	E.158
CZV 15 LG.....	E.14	JMPFV 06LG40.....	E.112	JPI 25 L.....	E.19	M7APW 16.40.....	E.158
CZV 25 L.....	E.17	JMPFV 10 G25.....	E.114	JSHF 06 S.....	B.58	M7APW 16.232.....	E.158
CZV 25 LG.....	E.16	JMPFV 10 G32.....	E.114	JSHF 10 S.....	B.59	M7APW 16.240.....	E.158
CZVS 15 L.....	E.41	JMPFV 10 G40.....	E.114	JSHF 16 S.....	B.60*	M7APW 24.32.....	E.160
CZVS 25 L.....	E.43	JMPFV 10LG25.....	E.113	JSHF 16 SN.....	B.62	M7APW 24.40.....	E.160
CZVW 15 L.....	E.29	JMPFV 10LG32.....	E.113	JSHF 24 S.....	B.61*	M7APW 24.232.....	E.160
CZVW 25 L.....	E.31	JMPFV 10LG40.....	E.113	JSHF 24 SN.....	B.63	M7APW 24.240.....	E.160
		JMPFV 16 G25.....	E.116	JSHM 06 S.....	B.58	M7P 06 L20.....	E.124
		JMPFV 16 G32.....	E.116	JSHM 10 S.....	B.59	M7P 06 L220.....	E.124
		JMPFV 16 G40.....	E.116	JSHM 16 S.....	B.60*	M7P 06 LS20.....	E.124
		JMPFV 16LG25.....	E.115	JSHM 16 SN.....	B.62	M7P 10.20.....	E.125
		JMPFV 16LG32.....	E.115	JSHM 24 S.....	B.61*	M7P 10 L220.....	E.125
		JMPFV 16LG40.....	E.115	JSHM 24 SN.....	B.63	M7P 16.25.....	E.126
		JMPFV 24 G25.....	E.118			M7P 16 L225.....	E.126
		JMPFV 24 G32.....	E.118			M7P 24.25.....	E.127
		JMPFV 24 G40.....	E.118			M7P 24 L225.....	E.127
		JMPFV 24LG25.....	E.117			M7PE 06 L20.....	E.174
		JMPFV 24LG32.....	E.117			M7PE 06 L220.....	E.174
		JMPFV 24LG40.....	E.117			M7PE 10.20.....	E.176
		JMPP 06 L20.....	E.112				
				M			
				M7AP 06 L32.....	E.124		
				M7AP 06 L40.....	E.124		

J

JKF 03.....	A.17
JKF 04.....	A.17
JKM 03.....	A.17
JKM 04.....	A.17
JMPAP 06 L25.....	E.112
JMPAP 06 L32.....	E.112
JMPAP 06 L40.....	E.112
JMPAP 06L225.....	E.112

* These items are also shown in various sections throughout the catalogue

M7PE 10.220	E.176	MAP 10 LS232	E.54	MAV 06 YX32	E.255	MBV 24.240D	E.278
M7PE 16.25	E.178	MAP 10 LS240	E.54	MAV 10 X32	E.59	MBV 24.240DG	E.279
M7PE 16.225	E.178	MAP 10 YC232	E.256	MAV 10 X40	E.59	MBV 24.332	E.271
M7PE 24.25	E.180	MAP 16.25	E.64	MAV 10 YX32	E.257	MBV 24.425	E.271
M7PE 24.225	E.180	MAP 16.32	E.64	MAV 10 YX40	E.257	MBV 24.720	E.271
M7PW 06 L32	E.154	MAP 16.40	E.64	MAV 16 X32	E.67	MBVO 06 L240	E.268
M7PW 06 L232	E.154	MAP 16.225	E.64	MAV 16 X40	E.67	MBVO 10.240	E.269
M7PW 10.20	E.156	MAP 16.232	E.64	MAV 16 YX32	E.259	MBVO 16.240	E.270
M7PW 10.220	E.156	MAP 16.240	E.64	MAV 16 YX40	E.259	MBVO 24.250	E.271
M7PW 16.25	E.158	MAP 16 CP32	E.66	MAV 24 X32	E.75	MBVO 24.440D	E.278
M7PW 16.225	E.158	MAP 16 CP40	E.66	MAV 24 X40	E.75	MBVO24.440DG	E.279
M7PW 24.25	E.160	MAP 16 CP232	E.66	MAV 24 YX32	E.261	MFF 10.20	E.61
M7PW 24.225	E.160	MAP 16 CP240	E.66	MAV 24 YX40	E.261	MFF 16.25	E.69
MAO 06 YX25	E.255	MAP 16 CS32	E.66	MAVE 06 L32	E.183	MFF 16.225	E.69
MAO 06 YX32	E.255	MAP 16 CS40	E.66	MAVE 06 LG32	E.182	MFF 24.25	E.77
MAO 10 X32	E.59	MAP 16 CS232	E.66	MAVE 10 G32	E.184	MFF 24.225	E.77
MAO 10 X40	E.59	MAP 16 CS240	E.66	MAVE 16 G32	E.186	MFO 06 L25	E.49
MAO 10 YX32	E.257	MAP 16 L32	E.62	MAVE 24 G32	E.188	MFO 06 L32	E.49
MAO 10 YX40	E.257	MAP 16 L40	E.62	MAVE 50.32	E.39	MFO 06 L40	E.49
MAO 16 X32	E.67	MAP 16 L232	E.62	MAVW 06 L32	E.155	MFO 06 LG40	E.48
MAO 16 X40	E.67	MAP 16 L240	E.62	MAVW 06 LG32	E.162	MFO 10.32	E.57
MAO 16 YX32	E.259	MAP 16 LS32	E.62	MAVW 10.32	E.157	MFO 10.40	E.57
MAO 16 YX40	E.259	MAP 16 LS40	E.62	MAVW 10 G32	E.163	MFO 10 G40	E.56
MAO 24 X32	E.75	MAP 16 LS232	E.62	MAVW 16.32	E.159	MFO 10 L32	E.55
MAO 24 X40	E.75	MAP 16 LS240	E.62	MAVW 16.40	E.159	MFO 10 L40	E.55
MAO 24 YX32	E.261	MAP 16 YC232	E.258	MAVW 16 G32	E.164	MFO 10 LG40	E.54
MAO 24 YX40	E.261	MAP 24.25	E.72	MAVW 24.32	E.161	MFO 16.32	E.65
MAOE 06 L32	E.183	MAP 24.32	E.72	MAVW 24.40	E.161	MFO 16.40	E.65
MAOE 50.32	E.39	MAP 24.40	E.72	MAVW 24 G32	E.165	MFO 16 G40	E.64
MAOW 06 L32	E.155	MAP 24.225	E.72	MAVW 50.32	E.32	MFO 16 L32	E.63
MAOW 10.32	E.157	MAP 24.232	E.72	MAVX 50 G32	E.24	MFO 16 L40	E.63
MAOW 16.32	E.159	MAP 24.240	E.72	MBO 06 L40	E.268	MFO 16 LG40	E.62
MAOW 16.40	E.159	MAP 24 CP32	E.74	MBO 06 L50	E.268	MFO 24.32	E.73
MAOW 24.32	E.161	MAP 24 CP40	E.74	MBO 10.40	E.269	MFO 24.40	E.73
MAOW 24.40	E.161	MAP 24 CP232	E.74	MBO 10.50	E.269	MFO 24 G40	E.72
MAOW 50.32	E.32	MAP 24 CP240	E.74	MBO 16.40	E.270	MFO 24 L32	E.71
MAP 06 L25	E.48	MAP 24 CS32	E.74	MBO 16.50	E.270	MFO 24 L40	E.71
MAP 06 L32	E.48	MAP 24 CS40	E.74	MBO 16.225	E.270	MFO 24 LG40	E.70
MAP 06 L40	E.48	MAP 24 CS232	E.74	MBO 16.225D	E.276	MFO 32.32	E.81
MAP 06 L225	E.48	MAP 24 CS240	E.74	MBO 16.225DG	E.277	MFO 32.40	E.81
MAP 06 L232	E.48	MAP 24 L32	E.70	MBO 24.40	E.271	MFO 32.50	E.81
MAP 06 L240	E.48	MAP 24 L40	E.70	MBO 24.50	E.271	MFO 32 L40	E.79
MAP 06 LS32	E.48	MAP 24 L232	E.70	MBO 24.225	E.271	MFO 32 X40	E.82
MAP 06 LS40	E.48	MAP 24 L240	E.70	MBV 06.40D	E.272	MFO 48 L32	E.85
MAP 06 LS232	E.48	MAP 24 LS32	E.70	MBV 06.40DG	E.273	MFO 48 L40	E.85
MAP 06 LS240	E.48	MAP 24 LS40	E.70	MBV 06 L40	E.268	MFO 48 L50	E.85
MAP 06 YC232	E.254	MAP 24 LS232	E.70	MBV 06 L50	E.268	MFO 50.25	E.21
MAP 10.25	E.56	MAP 24 LS240	E.70	MBV 06 L225	E.268	MFO 50.32	E.21
MAP 10.32	E.56	MAP 24 YC232	E.260	MBV 06 L320	E.268	MFO 50 X25	E.23
MAP 10.40	E.56	MAPE 06 L32	E.182	MBV 10.40	E.269	MFO 50 X32	E.23
MAP 10.225	E.56	MAPE 10.32	E.184	MBV 10.40D	E.274	MFOE 06 L32M	E.175
MAP 10.232	E.56	MAPE 16.32	E.186	MBV 10.40DG	E.275	MFOE 06 L40M	E.175
MAP 10.240	E.56	MAPE 24.32	E.188	MBV 10.50	E.269	MFOE 10.32	E.185
MAP 10 CP32	E.58	MAPN 06 L32	E.296	MBV 10.225	E.269	MFOE 10.32M	E.177
MAP 10 CP40	E.58	MAPN 10.32	E.298	MBV 10.420	E.269	MFOE 10.40M	E.177
MAP 10 CP232	E.58	MAPN 16.32	E.300	MBV 16.40	E.270	MFOE 16.32	E.187
MAP 10 CP240	E.58	MAPN 24.32	E.302	MBV 16.50	E.270	MFOE 16.32M	E.179
MAP 10 CS32	E.58	MAPS 06 L32	E.216	MBV 16.232	E.270	MFOE 16.40	E.187
MAP 10 CS40	E.58	MAPS 10.32	E.217	MBV 16.325	E.270	MFOE 16.40M	E.179
MAP 10 CS232	E.58	MAPS 16.32	E.218	MBV 16.620	E.270	MFOE 24.32	E.189
MAP 10 CS240	E.58	MAPS 24.32	E.219	MBV 16.620D	E.276	MFOE 24.32M	E.181
MAP 10 L32	E.54	MAPW 06 L32	E.162	MBV 16.620DG	E.277	MFOE 24.40	E.189
MAP 10 L40	E.54	MAPW 10.32	E.163	MBV 24.40	E.271	MFOE 24.40M	E.181
MAP 10 L232	E.54	MAPW 16.32	E.164	MBV 24.40D	E.278	MFON 06 L25	E.297
MAP 10 L240	E.54	MAPW 24.32	E.165	MBV 24.40DG	E.279	MFON 10.32	E.299
MAP 10 LS32	E.54	MAV 06LG25-F	E.53	MBV 24.50	E.271	MFON 16.32	E.301
MAP 10 LS40	E.54	MAV 06 YX25	E.255	MBV 24.240	E.271	MFON 24.32	E.303

* These items are also shown in various sections throughout the catalogue

MFOR 06 L32.....	I.19	MFV 24 L32.....	E.71	MFVW 48 L63.....	E.169	MGV 16.50 B.....	E.147
MFOR 10.32.....	I.21	MFV 24 L40.....	E.71	MFVX 50 X32.....	E.25	MGV 16.225.....	E.146
MFOR 16.40.....	I.23	MFV 24 LG25.....	E.70	MGK 2AP25.....	A.80	MGV 16.225 B.....	E.147
MFOR 24.32.....	I.25	MFV 24 LG32.....	E.70	MGK IAP20.....	A.78	MGV 24.32.....	E.148
MFOR 24.40.....	I.25	MFV 24 LG40.....	E.70	MGK V20.....	A.78	MGV 24.32 B.....	E.149
MFOR 32 L40.....	I.26	MFV 24 X40.....	E.82	MGK V20 B.....	A.79	MGV 24.40.....	E.148
MFOR 48 L40.....	I.27	MFV 32.32.....	E.81	MGK V25.....	A.78	MGV 24.40 B.....	E.149
MFOS 06 L32.....	E.209	MFV 32.40.....	E.81	MGK V25 B.....	A.79	MGV 24.50.....	E.148
MFOS 10.32.....	E.211	MFV 32.50.....	E.81	MGO 06.25.....	E.142	MGV 24.50 B.....	E.149
MFOS 16.32.....	E.213	MFV 32 G32.....	E.80	MGO 06.25 B.....	E.143	MGV 24.232.....	E.148
MFOS 16.40.....	E.213	MFV 32 G40.....	E.80	MGO 06.32.....	E.142	MGV 24.232 B.....	E.149
MFOS 24.32.....	E.215	MFV 32 G50.....	E.80	MGO 06.32 B.....	E.143	MGV 24.240.....	E.148
MFOS 24.40.....	E.215	MFV 32 L40.....	E.79	MGO 10.25.....	E.144	MGV 24.240 B.....	E.149
MFOV 06 L32.....	E.155	MFV 32 LG40.....	E.78	MGO 10.25 B.....	E.145	MGV 24.325.....	E.148
MFOV 10.32.....	E.157	MFV 48 L32.....	E.85	MGO 10.32.....	E.144	MGV 24.325 B.....	E.149
MFOV 16.32.....	E.159	MFV 48 L40.....	E.85	MGO 10.32 B.....	E.145	MGVE 06.25.....	E.194
MFOV 16.40.....	E.159	MFV 48 L50.....	E.85	MGO 16.32.....	E.146	MGVE 06.32.....	E.194
MFOV 24.32.....	E.161	MFV 48 L63.....	E.85	MGO 16.32 B.....	E.147	MGVE 06.40.....	E.194
MFOV 24.40.....	E.161	MFV 50.25.....	E.21	MGO 16.40.....	E.146	MGVE 10.25.....	E.195
MFOX 50 X32.....	E.25	MFV 50.32.....	E.21	MGO 16.40 B.....	E.147	MGVE 10.32.....	E.195
MFV 06 GYC25.....	E.254	MFV 50 G32.....	E.20	MGO 16.50.....	E.146	MGVE 10.40.....	E.195
MFV 06 GYC32.....	E.254	MFV 50 X25.....	E.23	MGO 16.50 B.....	E.147	MGVE 16.25.....	E.196
MFV 06 GYC40.....	E.254	MFV 50 X32.....	E.23	MGO 24.32.....	E.148	MGVE 16.32.....	E.196
MFV 06 L25.....	E.49	MFVE 06 L32M.....	E.175	MGO 24.32 B.....	E.149	MGVE 16.40.....	E.196
MFV 06 L32.....	E.49	MFVE 06 L40M.....	E.175	MGO 24.40.....	E.148	MGVE 16.50.....	E.196
MFV 06 L40.....	E.49	MFVE 10.32.....	E.185	MGO 24.40 B.....	E.149	MGVE 16.225.....	E.196
MFV 06 LG25.....	E.48	MFVE 10.32M.....	E.177	MGO 24.50.....	E.148	MGVE 24.32.....	E.197
MFV 06 LG32.....	E.48	MFVE 10.40M.....	E.177	MGO 24.50 B.....	E.149	MGVE 24.40.....	E.197
MFV 06 LG40.....	E.48	MFVE 16.32.....	E.187	MGOE 06.25.....	E.194	MGVE 24.50.....	E.197
MFV 10.32.....	E.57	MFVE 16.32M.....	E.179	MGOE 06.32.....	E.194	MGVE 24.232.....	E.197
MFV 10.40.....	E.57	MFVE 16.40.....	E.187	MGOE 10.25.....	E.195	MGVE 24.240.....	E.197
MFV 10.220.....	E.61	MFVE 16.40M.....	E.179	MGOE 10.32.....	E.195	MGVE 24.325.....	E.197
MFV 10 G25.....	E.56	MFVE 24.32.....	E.189	MGOE 16.32.....	E.196	MHO 06 L20.....	E.49
MFV 10 G32.....	E.56	MFVE 24.32M.....	E.181	MGOE 16.40.....	E.196	MHO 06 L25.....	E.49
MFV 10 G40.....	E.56	MFVE 24.40.....	E.189	MGOE 16.50.....	E.196	MHO 06 LX20.....	E.51
MFV 10 GYC25.....	E.256	MFVE 24.40M.....	E.181	MGOE 24.32.....	E.197	MHO 06 LX25.....	E.51
MFV 10 GYC32.....	E.256	MFVE 48 L63.....	E.193	MGOE 24.40.....	E.197	MHO 10.20.....	E.57
MFV 10 GYC40.....	E.256	MFVN 06 L25.....	E.297	MGOE 24.50.....	E.197	MHO 10.25.....	E.57
MFV 10 L32.....	E.55	MFVN 06 LG25.....	E.296	MGP 06.32.....	E.142	MHO 10 L20.....	E.55
MFV 10 L40.....	E.55	MFVN 10.32.....	E.299	MGP 10.32.....	E.144	MHO 10 L25.....	E.55
MFV 10 LG25.....	E.54	MFVN 10 G32.....	E.298	MGP 16.40.....	E.146	MHO 10 X20.....	E.59
MFV 10 LG32.....	E.54	MFVN 10 G220.....	E.298	MGP 24.40.....	E.148	MHO 10 X25.....	E.59
MFV 10 LG40.....	E.54	MFVN 16.32.....	E.301	MGP 24.240.....	E.148	MHO 16.25.....	E.65
MFV 16.32.....	E.65	MFVN 16 G32.....	E.300	MGPE 06.32.....	E.194	MHO 16.32.....	E.65
MFV 16.40.....	E.65	MFVN 16 G225.....	E.300	MGPE 10.32.....	E.195	MHO 16 L25.....	E.63
MFV 16.220.....	E.69	MFVN 24.32.....	E.303	MGPE 16.40.....	E.196	MHO 16 L32.....	E.63
MFV 16.225.....	E.69	MFVN 24 G32.....	E.302	MGPE 24.40.....	E.197	MHO 16 X25.....	E.67
MFV 16 G25.....	E.64	MFVN 24 G232.....	E.302	MGPE 24.240.....	E.197	MHO 16 X32.....	E.67
MFV 16 G32.....	E.64	MFVR 06 L32.....	I.19	MGV 06.25.....	E.142	MHO 24.25.....	E.73
MFV 16 G40.....	E.64	MFVR 10.32.....	I.21	MGV 06.25 B.....	E.143	MHO 24.32.....	E.73
MFV 16 GYC25.....	E.258	MFVR 16.40.....	I.23	MGV 06.32.....	E.142	MHO 24 L25.....	E.71
MFV 16 GYC32.....	E.258	MFVR 24.40.....	I.25	MGV 06.32 B.....	E.143	MHO 24 L32.....	E.71
MFV 16 GYC40.....	E.258	MFVR 32 L40.....	I.26	MGV 06.40.....	E.142	MHO 24 X25.....	E.75
MFV 16 L32.....	E.63	MFVR 48 L40.....	I.27	MGV 06.40 B.....	E.143	MHO 24 X32.....	E.75
MFV 16 L40.....	E.63	MFVR 48 L63.....	I.27	MGV 10.25.....	E.144	MHO 50.25.....	E.21
MFV 16 LG25.....	E.62	MFVS 06 L32.....	E.209	MGV 10.25 B.....	E.145	MHO 50.32.....	E.21
MFV 16 LG32.....	E.62	MFVS 10.32.....	E.211	MGV 10.32.....	E.144	MHO 50 X25.....	E.23
MFV 16 LG40.....	E.62	MFVS 16.32.....	E.213	MGV 10.32 B.....	E.145	MHO 50 X32.....	E.23
MFV 24.32.....	E.73	MFVS 16.40.....	E.213	MGV 10.40.....	E.144	MHOE 06 L20M.....	E.175
MFV 24.40.....	E.73	MFVS 24.32.....	E.215	MGV 10.40 B.....	E.145	MHOE 06 L25M.....	E.175
MFV 24.232.....	E.77	MFVS 24.40.....	E.215	MGV 16.25.....	E.146	MHOE 10.20M.....	E.177
MFV 24 G25.....	E.72	MFVW 06 L32.....	E.155	MGV 16.25 B.....	E.147	MHOE 10.25M.....	E.177
MFV 24 G32.....	E.72	MFVW 10.32.....	E.157	MGV 16.32.....	E.146	MHOE 16.25.....	E.187
MFV 24 G40.....	E.72	MFVW 16.32.....	E.159	MGV 16.32 B.....	E.147	MHOE 16.25M.....	E.179
MFV 24 GYC25.....	E.260	MFVW 16.40.....	E.159	MGV 16.40.....	E.146	MHOE 16.32.....	E.187
MFV 24 GYC32.....	E.260	MFVW 24.32.....	E.161	MGV 16.40 B.....	E.147	MHOE 16.32M.....	E.179
MFV 24 GYC40.....	E.260	MFVW 24.40.....	E.161	MGV 16.50.....	E.146	MHOE 24.25.....	E.189

* These items are also shown in various sections throughout the catalogue

MHOE 24.25M	E.181	MHP 32 L40	E.78	MHVE 10.20M	E.177	MKAS IAP25	A.85
MHOE 24.32	E.189	MHP 32 L50	E.78	MHVE 10.25M	E.177	MKAS IF	A.86
MHOE 24.32M	E.181	MHP 32 L240	E.78	MHVE 16.25	E.187	MKAS IVG20	A.87
MHOE 32.40	E.191	MHP 32 L250	E.78	MHVE 16.25M	E.179	MKAS V20	A.89
MHOE 48 L40	E.193	MHP 32 LS40	E.78	MHVE 16.32	E.187	MKAS V25	A.89
MHOE 50.25	E.39	MHP 32 LS50	E.78	MHVE 16.32M	E.179	MKAS VA20	A.89
MHOE 50.32	E.39	MHP 32 LS240	E.78	MHVE 24.25	E.189	MKAS VA25	A.89
MHON 06 L25	E.297	MHP 32 LS250	E.78	MHVE 24.25M	E.181	MKAS VG25	A.88
MHON 10.25	E.299	MHP 48 LS40	E.84	MHVE 24.32	E.189	MKA V20	A.64
MHON 16.32	E.301	MHP 48 LS50	E.84	MHVE 24.32M	E.181	MKA V25	A.64
MHON 24.32	E.303	MHP 50.32	E.20	MHVE 32.40	E.191	MKA VA20	A.64
MHOR 06 L20	1.19	MHP 50.40	E.20	MHVE 32 G40	E.190	MKA VA25	A.64
MHOR 10.20	1.21	MHP 50.232	E.20	MHVE 48 L40	E.193	MKA VG20	A.59
MHOR 16.25	1.23	MHP 50.240	E.20	MHVN 06 L25	E.297	MKA VG25	A.59
MHOR 24.25	1.25	MHP 50 CS32	E.22	MHVN 06 LG25	E.296	MKAW V20	A.75
MHOR 24.32	1.25	MHP 50 LS40	E.22	MHVN 10.25	E.299	MKAW V25	A.75
MHOS 16.25	E.213	MHP 50 LS232	E.22	MHVN 10 G25	E.298	MKAW VA20	A.75
MHOS 16.32	E.213	MHP 50 LS240	E.22	MHVN 16.32	E.301	MKAW VA25	A.75
MHOS 24.25	E.215	MHPE 32.50	E.190	MHVN 16 G32	E.300	MKAX AP20	A.56
MHOS 24.32	E.215	MHPE 48 LS40	E.192	MHVN 24.32	E.303	MKAX AP25	A.60
MHOW 16.25	E.159	MHPE 50.32	E.38	MHVN 24 G32	E.302	MKAXE AP20	A.76
MHOW 16.32	E.159	MHPE 50.240	E.38	MHVR 06 L20	1.19	MKAXE AP20	A.76
MHOW 24.25	E.161	MHPR 32 L40	1.26	MHVR 10.20	1.21	MKAXE IAF20	A.76
MHOW 24.32	E.161	MHPR 32 LS40	1.26	MHVR 16.25	1.23	MKAXE IAF25	A.76
MHOW 32.40	E.167	MHPR 48 L40	1.27	MHVR 24.25	1.25	MKAXE IAP20	A.76
MHOW 48 L40	E.169	MHPR 48 LS40	1.27	MHVS 16.25	E.213	MKAXE VG20	A.76
MHOW 50.25	E.32	MHPW 32.50	E.166	MHVS 16.32	E.213	MKAX IAF25	A.61
MHOW 50.32	E.32	MHPW 48 LS40	E.168	MHVS 24.25	E.215	MKAX IAP20	A.56
MHOX 50 X32	E.25	MHPW 50.32	E.32	MHVS 24.32	E.215	MKAX IAP25	A.60
MHP 06 L20	E.48	MHPW 50.240	E.32	MHVW 16.25	E.159	MKAX IF	A.61
MHP 06 L220	E.48	MHPX 32 L40	E.78	MHVW 16.32	E.159	MKAX IFC	A.61
MHP 06 LS20	E.48	MHPX 32 LP40	E.78	MHVW 24.25	E.161	MKAX IVG20	A.62
MHP 06 LS220	E.48	MHPX 32 LP50	E.78	MHVW 24.32	E.161	MKAXR AP20	1.16
MHP 10.20	E.56	MHPX 32 LS40	E.78	MHVW 32.40	E.167	MKAXR AP20	1.16
MHP 10.220	E.56	MHPX 50.32	E.24	MHVW 32 G40	E.166	MKAXR IF	1.16
MHP 10 CP20	E.58	MHPXW 50.32	E.33	MHVW 48 L40	E.169	MKAXR VG20	1.16
MHP 10 CP220	E.58	MHV 06 L20	E.49	MIO 16.40	E.69	MKAXS AP20	A.84
MHP 10 CS20	E.58	MHV 06 L25	E.49	MIO 16.50	E.69	MKAXS AP25	A.85
MHP 10 CS220	E.58	MHV 06 LG25	E.48	MIO 24.40	E.77	MKAXS IAP20	A.84
MHP 10 L20	E.54	MHV 06 LX20	E.51	MIO 24.50	E.77	MKAXS IAP25	A.85
MHP 10 L220	E.54	MHV 06 LX25	E.51	MIO 24 YX40	E.261	MKAXS IF	A.86
MHP 10 LS20	E.54	MHV 10.20	E.57	MIO 24 YX50	E.261	MKAXS IVG20	A.87
MHP 10 LS220	E.54	MHV 10.25	E.57	MIV 16.40	E.69	MKAXS VG20	A.88
MHP 16.25	E.64	MHV 10 G25	E.56	MIV 24.40	E.77	MKAXS VG25	A.88
MHP 16.225	E.64	MHV 10 L20	E.55	MIV 24.50	E.77	MKAX VG20	A.57
MHP 16 CP25	E.66	MHV 10 L25	E.55	MIV 24 YX40	E.261	MKAX VG25	A.57
MHP 16 CP225	E.66	MHV 10 LG25	E.54	MIV 24 YX50	E.261	MKAXW AP20	A.73
MHP 16 CS25	E.66	MHV 10 X20	E.59	MKA AP20	A.58	MKAXW AP25	A.73
MHP 16 CS225	E.66	MHV 10 X25	E.59	MKA AP25	A.63	MKAXW AP20	A.73
MHP 16 L25	E.62	MHV 16.25	E.65	MKAE V20	A.77	MKAXW IAP25	A.73
MHP 16 L225	E.62	MHV 16.32	E.65	MKAE VA20	A.77	MKAXW IF	A.72
MHP 16 LS25	E.62	MHV 16 G32	E.64	MKAG V20	A.66	MKAXW VG20	A.74
MHP 16 LS225	E.62	MHV 16 L25	E.63	MKAG V25	A.66	MKAXW VG25	A.74
MHP 24.25	E.72	MHV 16 L32	E.63	MKAG VA20	A.66	MKAXX AP25	A.63
MHP 24.225	E.72	MHV 16 LG32	E.62	MKAG VA25	A.66	MKAXX IAP25	A.63
MHP 24 CP25	E.74	MHV 16 X25	E.67	MKA IAF20	A.61	MKAXX IF	A.61
MHP 24 CP225	E.74	MHV 16 X32	E.67	MKA IAF25	A.61	MKAXX IFC	A.61
MHP 24 CS25	E.74	MHV 24.25	E.73	MKA IAP20	A.58	MKAXX IVG20	A.62
MHP 24 CS225	E.74	MHV 24.32	E.73	MKA IAP25	A.63	MKAXXR IF	1.16
MHP 24 L25	E.70	MHV 24 G32	E.72	MKA IF	A.61	MKAXXS AP25	A.85
MHP 24 L225	E.70	MHV 24 L25	E.71	MKA IFC	A.61	MKAXXS IAP25	A.85
MHP 24 LS25	E.70	MHV 24 L32	E.71	MKA IVG20	A.62	MKAXXS IF	A.86
MHP 24 LS225	E.70	MHV 24 LG32	E.70	MK AP25	A.47	MKAXXS IVG20	A.87
MHP 32.40	E.80	MHV 24 X25	E.75	MK APN25	A.47	MKAXXS VG25	A.88
MHP 32.50	E.80	MHV 24 X32	E.75	MKAR V20	1.17	MKAXX VG25	A.59
MHP 32.240	E.80	MHVE 06 L20M	E.175	MKAR VA20	1.17	MKAXXW AP25	A.73
MHP 32.250	E.80	MHVE 06 L25M	E.175	MKAS AP25	A.85	MKAXXW IAP25	A.73

* These items are also shown in various sections throughout the catalogue

MKAXXW IF	A.72	MLAP 10 LS32	E.92	MLFO 16 G40.....	E.99	MLV 24 LG32	E.101
MKAXXW VG25	A.74	MLAP 10 LS40	E.92	MLFO 16 LG40.....	E.97	MLV 24 X25	E.107
MKGGH V20	A.96	MLAP 10LS232	E.92	MLFO 24 G40	E.103	MLV 24 X32	E.107
MKGGH V25	A.96	MLAP 10LS240	E.92	MLFO 24 LG40.....	E.101	MQ 08 VO225	E.7
MKGGH VA20	A.96	MLAP 16.25	E.98	MLFV 06 LG25	E.91	MQA 08 O25	E.10
MKGGH VA25	A.96	MLAP 16.32	E.98	MLFV 06 LG32	E.91	MQA 08 V25	E.10
MKG V20	A.52	MLAP 16.40	E.98	MLFV 06 LG40.....	E.91	MQA 08 VO220.....	E.10
MKG V25	A.52	MLAP 16.225	E.98	MLFV 10 G25	E.95	MQA 08 VO225.....	E.10
MKG VA20	A.52	MLAP 16.232	E.98	MLFV 10 G32.....	E.95	MQO 24.40	E.77
MKG VA25	A.52	MLAP 16.240	E.98	MLFV 10 G40	E.95	MQS 08 VO225.....	E.9
MKG VAN20	A.52	MLAP 16 L32	E.96	MLFV 10 LG25	E.93	MQV 24.40	E.77
MKG VAN25	A.52	MLAP 16 L40	E.96	MLFV 10 LG32	E.93	MVAP 06 LP32.....	E.128
MKG VN20	A.52	MLAP 16 L232	E.96	MLFV 10 LG40.....	E.93	MVAP 06 LP40.....	E.128
MKG VN25	A.52	MLAP 16 L240	E.96	MLFV 16 G25	E.99	MVAP 06LP232	E.128
MKH AP25	A.94	MLAP 16 LS32	E.96	MLFV 16 G32	E.99	MVAP 06LP240	E.128
MKH IAP20	A.94	MLAP 16 LS40	E.96	MLFV 16 G40.....	E.99	MVAP 06 LS32.....	E.128
MKH IAP25	A.94	MLAP 16LS232	E.96	MLFV 16 LG25	E.97	MVAP 06 LS40	E.128
MKH V20	A.96	MLAP 16LS240	E.96	MLFV 16 LG32	E.97	MVAP 06LS232	E.128
MKH V25	A.96	MLAP 24.25	E.102	MLFV 16 LG40.....	E.97	MVAP 06LS240.....	E.128
MKH VA20	A.96	MLAP 24.32	E.102	MLFV 24 G25	E.103	MVAP 06LSP25	E.128
MKH VA25	A.96	MLAP 24.40	E.102	MLFV 24 G32.....	E.103	MVAP 06LSP32	E.128
MKH VG20	A.95	MLAP 24.225	E.102	MLFV 24 G40.....	E.103	MVAP 06LSP40	E.128
MKH VG25	A.95	MLAP 24.232	E.102	MLFV 24 LG25	E.101	MVAP 10 L32	E.131
MK IAP20	A.46	MLAP 24.240	E.102	MLFV 24 LG32.....	E.101	MVAP 10 L40	E.131
MK IAP25	A.46	MLAP 24 L32	E.100	MLFV 24 LG40.....	E.101	MVAP 10 L232	E.131
MK IAPN20	A.46	MLAP 24 L40	E.100	MLO 06 LX20.....	E.104	MVAP 10 L240	E.131
MK IAPN25	A.46	MLAP 24 L232	E.100	MLO 06 LX25.....	E.104	MVAP 10 LP32.....	E.130
MK V20.....	A.49	MLAP 24 L240	E.100	MLO 10 X20	E.105	MVAP 10 LP40.....	E.130
MK V25.....	A.49	MLAP 24 LS32	E.100	MLO 10 X25	E.105	MVAP 10LP232.....	E.130
MK VA20	A.49	MLAP 24 LS40	E.100	MLO 16 X25	E.106	MVAP 10LP240.....	E.130
MK VA25	A.49	MLAP 24LS232	E.100	MLO 16 X32	E.106	MVAP 10 LS32.....	E.130
MK VAN20	A.49	MLAP 24LS240	E.100	MLO 24 X25	E.107	MVAP 10 LS40.....	E.130
MK VAN25	A.49	MLAPS 06 L25	E.208	MLO 24 X32	E.107	MVAP 10LS232.....	E.130
MK VG20	A.48	MLAPS 06 L32	E.208	MLP 06 L20.....	E.90	MVAP 10LS240.....	E.130
MK VG25	A.48	MLAPS 10.25	E.210	MLP 06 L220.....	E.90	MVAP 10LSP25	E.130
MK VGN20	A.48	MLAPS 10.32	E.210	MLP 06 LS20	E.90	MVAP 10LSP32	E.130
MK VGN25	A.48	MLAPS 16.32	E.212	MLP 06 LS220	E.90	MVAP 10LSP40	E.130
MK VN20	A.49	MLAPS 16.40	E.212	MLP 10.20.....	E.94	MVAP 16 L32	E.133
MK VN25	A.49	MLAPS 24.32	E.214	MLP 10.220	E.94	MVAP 16 L40	E.133
MKX AP25	A.54	MLAPS 24.40	E.214	MLP 10 L20	E.92	MVAP 16 L232	E.133
MKX IAP25	A.53	MLAV 06 LG25	E.91	MLP 10 L220	E.92	MVAP 16 L240	E.133
MLAO 10 X32	E.105	MLAV 06 LG32	E.91	MLP 10 L220	E.92	MVAP 16 LP32	E.132
MLAO 10 X40	E.105	MLAV 10 G25	E.95	MLP 10 LS220	E.92	MVAP 16 LP40	E.132
MLAO 16 X32	E.106	MLAV 10 G32	E.95	MLP 16.25	E.98	MVAP 16LP232	E.132
MLAO 16 X40	E.106	MLAV 10 G40	E.95	MLP 16.225	E.98	MVAP 16LP240	E.132
MLAO 24 X32	E.107	MLAV 10 LG25	E.93	MLP 16 L25	E.96	MVAP 16 LS32	E.132
MLAO 24 X40	E.107	MLAV 10 LG32	E.93	MLP 16 L225	E.96	MVAP 16 LS40	E.132
MLAP 06 L25	E.90	MLAV 10 X32	E.105	MLP 16 LS25	E.96	MVAP 16LS232	E.132
MLAP 06 L32	E.90	MLAV 10 X40	E.105	MLP 16 LS225	E.96	MVAP 16LS240	E.132
MLAP 06 L40	E.90	MLAV 16 G25	E.99	MLP 24.25	E.102	MVAP 16LSP25	E.132
MLAP 06 L225	E.90	MLAV 16 G32	E.99	MLP 24.225	E.102	MVAP 16LSP32	E.132
MLAP 06 L232	E.90	MLAV 16 G40	E.99	MLP 24 L25	E.100	MVAP 16LSP40	E.132
MLAP 06 L240	E.90	MLAV 16 LG25	E.97	MLP 24 L225	E.100	MVAP 24 L32	E.135
MLAP 06 LS32	E.90	MLAV 16 LG32	E.97	MLP 24 LS25	E.100	MVAP 24 L40	E.135
MLAP 06 LS40	E.90	MLAV 16 LG40	E.97	MLP 24 LS225	E.100	MVAP 24 L232	E.135
MLAP 06LS232	E.90	MLAV 16 X32	E.106	MLV 06 LG25	E.91	MVAP 24 L240	E.135
MLAP 06LS240	E.90	MLAV 16 X40	E.106	MLV 06 LX20	E.104	MVAP 24 LP32	E.134
MLAP 10.25	E.94	MLAV 24 G25	E.103	MLV 06 LX25	E.104	MVAP 24 LP40	E.134
MLAP 10.32	E.94	MLAV 24 G32	E.103	MLV 10 G25	E.95	MVAP 24LP232	E.134
MLAP 10.40	E.94	MLAV 24 G40	E.103	MLV 10 LG25	E.93	MVAP 24LP240	E.134
MLAP 10.225	E.94	MLAV 24 LG25	E.101	MLV 10 X20	E.105	MVAP 24 LS32	E.134
MLAP 10.232	E.94	MLAV 24 LG32	E.101	MLV 10 X25	E.105	MVAP 24 LS40	E.134
MLAP 10.240	E.94	MLAV 24 LG40	E.101	MLV 16 G32	E.99	MVAP 24LS232	E.134
MLAP 10 L32	E.92	MLAV 24 X32	E.107	MLV 16 LG32	E.97	MVAP 24LS240	E.134
MLAP 10 L40	E.92	MLAV 24 X40	E.107	MLV 16 X25	E.106	MVAP 24LSP25	E.134
MLAP 10 L232	E.92	MLFO 06 LG40	E.91*	MLV 16 X32	E.106	MVAP 24LSP32	E.134
MLAP 10 L240	E.92	MLFO 10 G40.....	E.95	MLV 24 G32	E.103	MVAP 24LSP40	E.134

* These items are also shown in various sections throughout the catalogue

Worldwide Sales Organization

Headquarters

ILME S.p.A.

Via M.A. Colonna, 9
20149 Milano, Italia
T +39 0234560522
info@ilme.com

France

ILME FRANCE S.A.R.L.

431 rue Roland Garros
Parc d'Activités de l'Aéroport
42160 Andrézieux-Bouthéon
T +33 04 7736 2336
ilme-france@ilme.fr

Germany

ILME GmbH

Max-Planck-Straße 12
51674 Wiehl
T +49 (0)2261 7955 0
technik@ilme.de

Sweden

and Nordic Countries

ILME NORDIC AB

Transportvägen 18
246 42 Löddeköpinge
T +46 4618 2800
support@ilme.se

United Kingdom

ILME UK LIMITED

50 Evans Road, Venture Point
Speke, Liverpool L24 9PB
T +44 0151 336 9321
sales@ilmeuk.co.uk

Czech Republic

Representative Office

ILME S.p.A.

Business Center Rokytká
Sokolovská 270/201
Vysocany, Praha 9, 190 00
info@ilme.cz

China

ILME CHINA CO., LTD.

Room 101, Building 3
188 Xinjunhuan Road, Minhang
Shanghai 201114
T +86 21 6248 9961
info@ilmechina.com

Japan

ILME JAPAN CO., LTD.

K.I.B.C. Bldg 5-2
Minatojima Minamimachi 5-Chome
Chuo-Ku, Kobe 650-0047
T +81 78 302 2005
info@ilmejapan.co.jp

South Korea

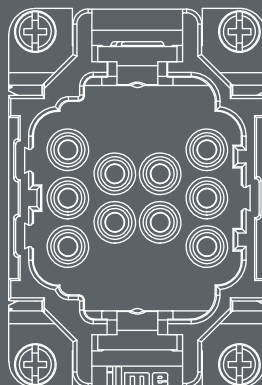
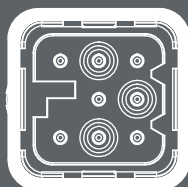
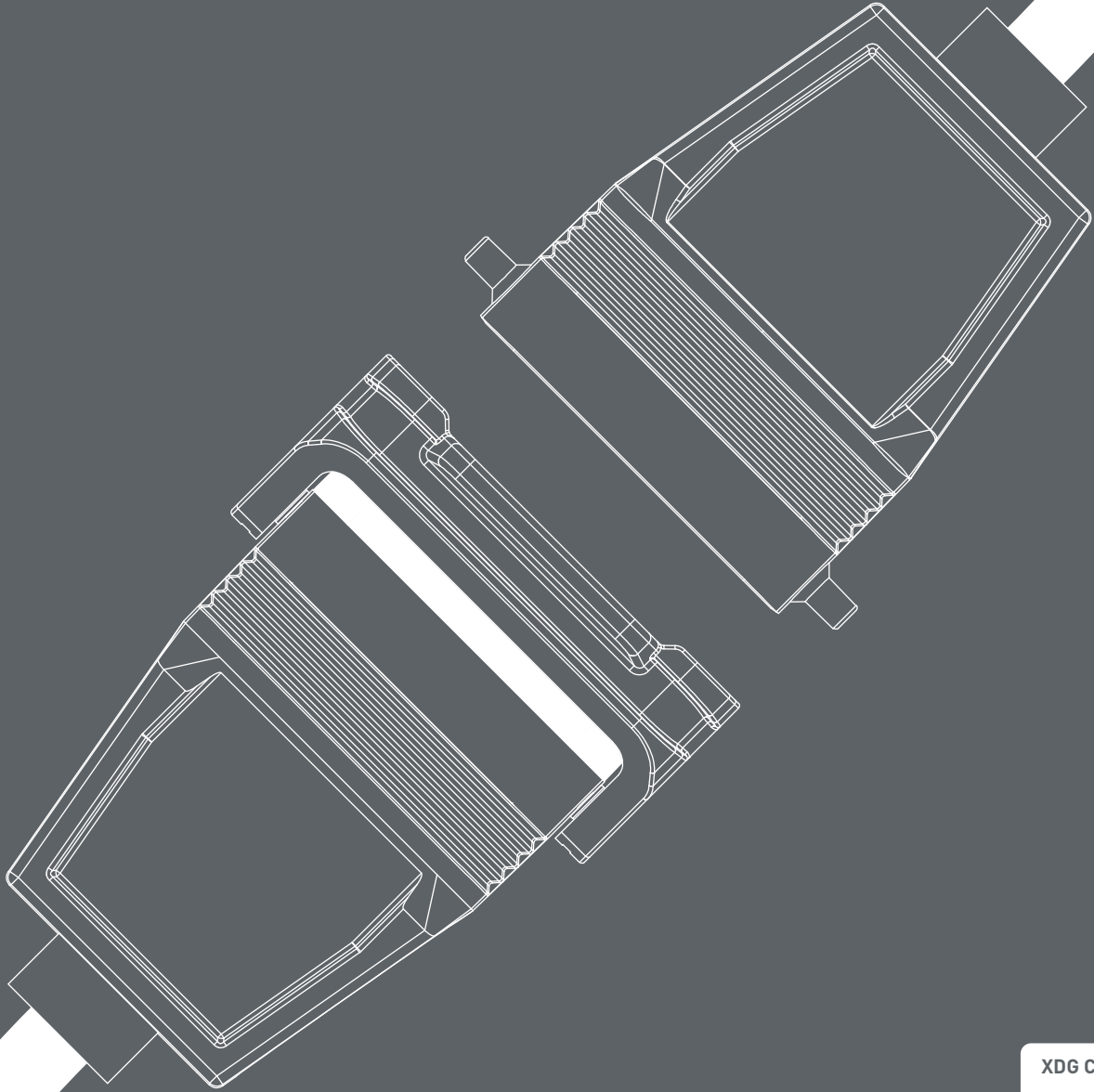
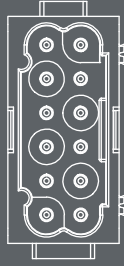
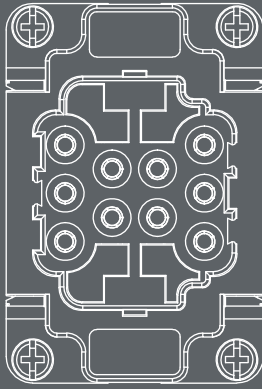
ILME KOREA CO.

714, DaeRyung Technotown 20th
5 Gasan Digital 1-Ro, GeumCheon-Gu
Seoul 08594
T +82-2-2225-8432
sales@ilme.kr

www.ilme.com



ILME S.p.A.
Via M.A. Colonna 9
20149 Milano, Italy
www.ilme.com



XDG CN 425

