



CA12, CA18 and CA30 capacitive IO-Link sensors

Sensors

CA12/18/30 series

IO-Link capacitive proximity sensors

Carlo Gavazzi is proud to introduce this series of high-quality capacitive sensors to meet the demands of a new industrial era; an era that requires devices with enhanced capabilities and new ways of accessing, communicating and processing data. The Carlo Gavazzi IO-Link sensors combine their excellent features with the benefits of the IO-Link standard, which opens up the access to detailed information, advanced functionality and flexibility.

The IO-Link system provides significant advantages including enhanced data availability and workability, remote configuration and automatic parameter settings, advanced diagnostics, simplified installation and easy sensor replacement.

Get ready for the era of Industry 4.0 and the Industrial Internet of Things!

8

PREDICTIVE MAINTENANCE

1

CONFIGURABLE SENSORS

7

MULTI-FUNCTION DEVICE

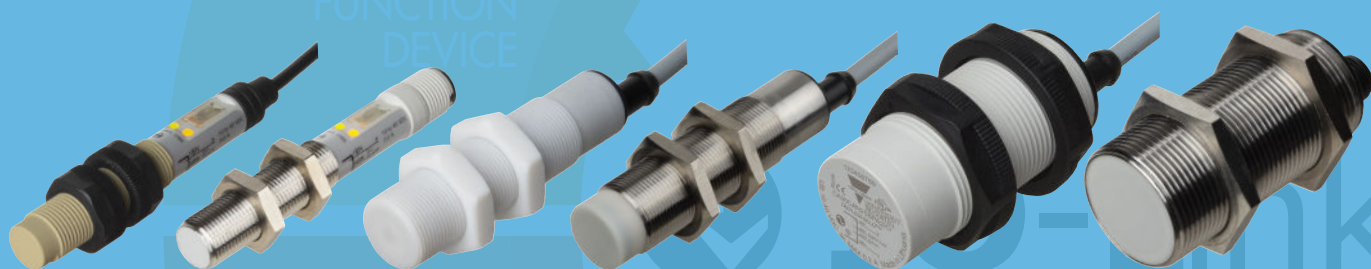

Universal, smart and easy



Data availability down to the field level

Using IO-Link, the sensors can deliver their data directly into the control system very efficiently.

Device identification

Each IO-Link sensor has an IODD (IO Device Description), which describes the sensor, its capabilities and parameters, process data, diagnosis data and user interface configuration. Furthermore, each sensor is equipped with an internal ID.

Automatic parameter settings

Initial setup of a new sensor is smooth and easy using previously stored parameters. Once a sensor has been replaced, the IO-Link master simply transmits parameters stored from the old sensor.

Centralized configuration and data management

IO-Link enables fast configuration and dynamic change of the sensor parameters on the fly, which considerably reduces downtime in case of product changeover and increases flexibility and diversity of the installation.

Universal, smart and easy

Simplified installation

An IO-Link system requires just standard, unshielded 3-wire cables, and a standardized uniform interface for sensors and actuators, which drastically reduces the complexity of the installation process. In addition, the automated parameter reassignment simplifies sensor replacement in case of defects and prevents incorrect settings. The IO-Link-enabled sensor acts as a standard sensor when installed in a non-IO-Link system, so the same sensor can

be stocked for both standard I/O (SIO) applications and IO-Link applications.

Simplified configuration with the Handheld IO-Link SCTL55 smart configurator

By using the Handheld IO-Link SCTL55 smart configurator from Carlo Gavazzi it is very smart and easy to configure your IO-Link sensor. When the SCTL55 smart configurator has automatically downloaded the sensor's IODD file you are ready to configure.



IO-Link

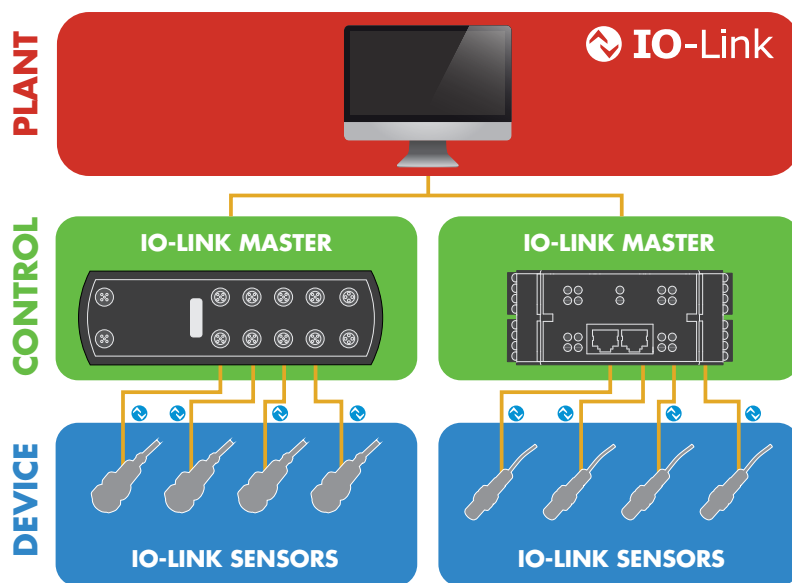

What is IO-Link?

IO-Link is an open communication universal standard protocol that allows IO-Link-enabled devices to exchange, collect and analyse data and convert it into actionable information.

IO-Link is recognised worldwide as an international standard (IEC 61131-9), and it is today considered as the "USB interface" for sensors and actuators in the industrial automation environment.

Plug and play

When the IO-Link sensor is connected to an IO-Link port, the IO-Link master sends a wake-up request to the sensor, which automatically switches to IO-Link mode, and a point-to-point bidirectional communication automatically starts between the master and the sensor.

Operating modes

The IO-Link-capable sensor can operate in two different modes; SIO mode (standard I/O) or IO-Link mode.

- SIO mode: the sensor works as a traditional sensor, and pin 4 acts as an ordinary digital output. SIO mode ensures backwards compatibility with standard sensor systems.
- IO-Link mode: exchange of data between sensor and IO-Link master takes place, and pin 4 is used for the transmission of IO-Link-related data.

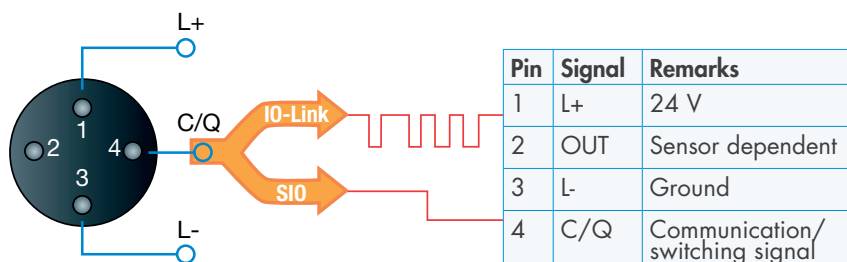

CA12/18/30 series

IO-Link capacitive proximity sensors

IO-Link functions

Fully configurable

IO-Link provides the first globally standardised interface for communication with the sensor. Once you have connected the sensor to the IO-Link port, you can access a multitude of configuration parameters and advanced functionalities. This way, the sensor can be tailored to meet your individual needs and requirements at a given time. The settings can also be stored in the master and can always be changed if the need occurs, or they can be smoothly transferred to a new sensor in case of sensor replacement.

1. Outputs/inputs

The sensor has two I/O terminals.

2. NPN, PNP, Push-pull, External input

The I/O terminals can be configured as: NPN, PNP, push-pull or external input (only output 2).

3. Normally open (N.O.) Normally closed (N.C.)

The output can be configured to normally open or normally closed.

4. Timer function

It is possible to activate different timer functions: ON delay, OFF delay, ON and OFF delay or one shot (leading edge or trailing edge).

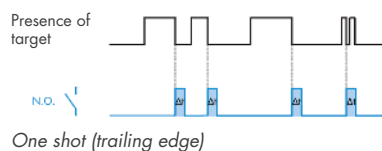
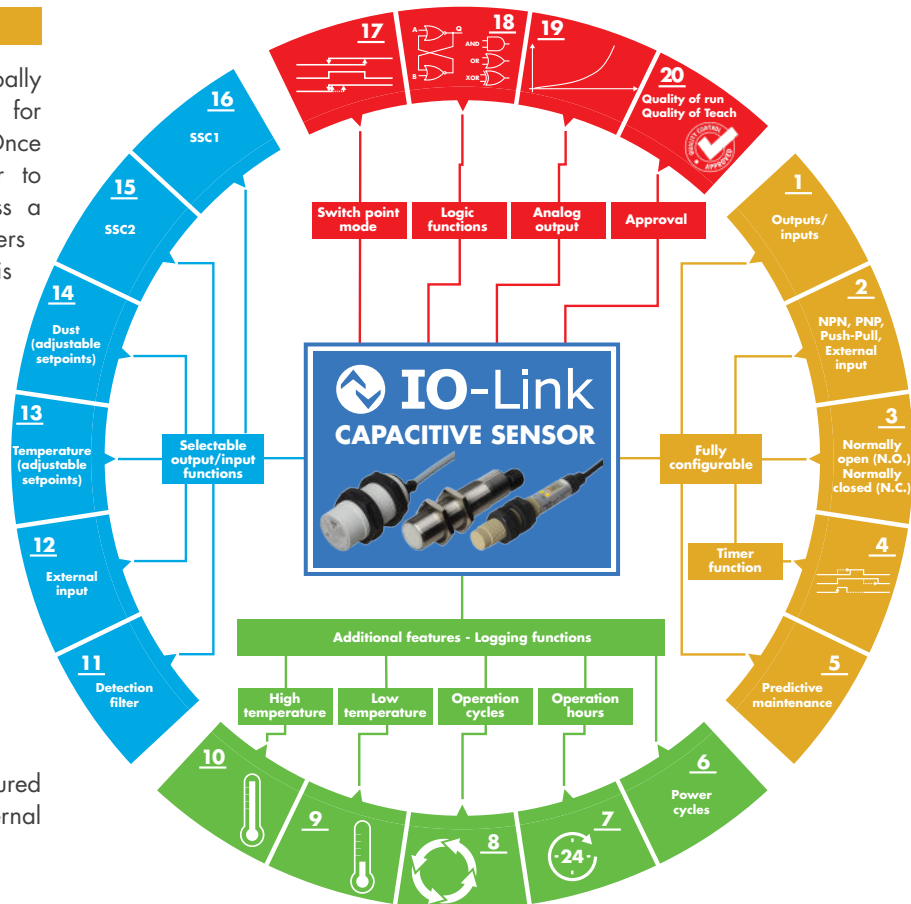
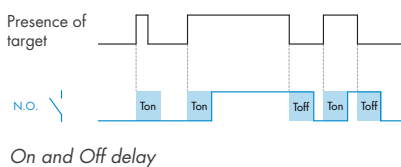
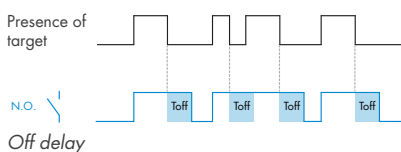
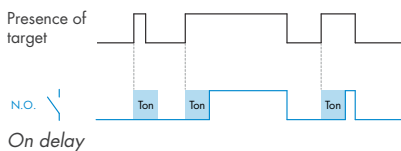

5. Predictive maintenance

The sensors can provide information about their basic status during normal operation, for instance an increase in contamination (dust build up). Maintenance can be requested before a system fails, thereby avoiding costly machine downtime.

Additional logging functions

The Carlo Gavazzi capacitive IO-Link sensors offer additional logging functions for advanced diagnostic mechanisms making both real-time and historic data available.

6. Power cycles

Counts and stores how many times the sensor has been powered up since its creation.

7. Operating hours

Counts and stores number of hours of power connected since its creation.

8. Operation cycle

Number of sensor detections (SSC1) since its creation.

9. Low temperature

Two different specifics are measured: The lowest temperature the sensor has been exposed to since

1. its creation (stored in sensor)
2. since last power-up.

10. High temperature

Two different specifics are logged: The highest temperature the sensor has been exposed to since

1. its creation (stored in sensor)
2. since last power-up.

IO-Link functions

Selectable output/ input functions

11. Detection filter

It is a stabilising filter that increases the immunity to the variation in the sensor's measurements and media. The detection filter can be set to measure the average value of 1 to 255 measurements.

12. External input

The external input can be controlled by outputs from sensors or PLC's.

13. Temperature alarm

The sensor can be configured to give an alarm if the temperature exceeds or drops below a preset value (Tmax or Tmin).

14. Dust alarm

The sensor can be configured to give an alarm if the contamination level exceeds a preset value of choice.

15. SSC1

The Switching Signal Channel 1 (SSC1) output can be configured to the following four detection modes: Single-point mode, two-point mode, windows mode and adjustable hysteresis. Two individual setpoints and hysteresis can be set.

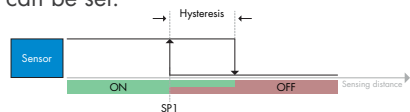

Single point mode

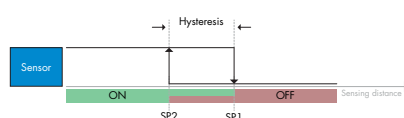

Two point mode

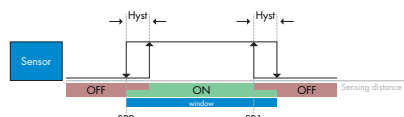

Windows mode

16. SSC2

The Switching Signal Channel 2 (SSC2) output can be configured to the same modes as SSC1.

Two individual setpoints and hysteresis can be set.

Switch point mode

17. Switch point mode

SSC1 and SSC2 can be configured to single-point mode, two-point mode, windows mode, adjustable hysteresis.

Logic functions

18. Logic functions

In the logic function block a logic function can be added directly to the selected signals from the input selector without using a PLC – making decentral decisions possible.

The logic functions available are: AND, OR, XOR and Gated SR-FF.

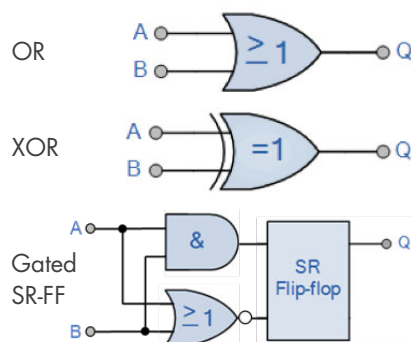
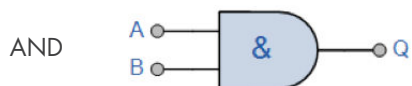

Analogue output

19. Analogue output

16 bit Analogue Output by IO-Link representing the Dielectric value measured by the sensor.

Approval

20. Quality of run

The quality of run value informs about the actual sensing performance compared to the set-points of the sensor, the higher the value the better quality of detection.



20. Quality of teach

The quality of teach value informs about how well the actually teach procedure was done, meaning the margin between the actual setpoints and the environmental influence of the sensor.

Protection *

4th Generation TRIPLESIELD™ technology



* Values differ for CA12

ECOLAB®

IP69K

CA12/18/30 series

IO-Link sensors in PBT housing

Features and functions

CA12CAF.IO Flush



CA12CAN..IO Non-Flush



All versions are available as Flush or Non-flush and cable or M12 plug versions.

Top part of the sensor

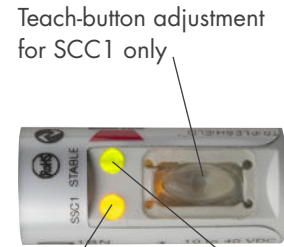

Yellow LED

- Output
- Short circuit
- Timer
- Find my sensor

Green LED

- Power
- Stability
- IO-Link communication
- Find my sensor

CA18CAF.IO Flush



CA18CAN..IO Non-Flush



All versions are available as Flush or Non-flush and cable or M12 plug versions.

Back part of the sensor

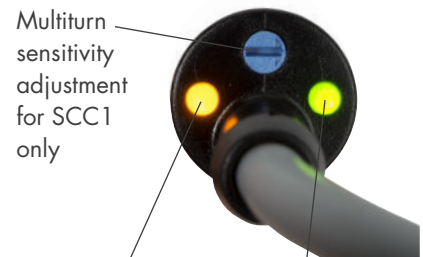

Yellow LED

- Output
- Short circuit
- Timer

Green LED

- Power
- Stability
- IO-Link communication

CA30CAF.IO Flush



CA30CAN..IO Non-Flush



All versions are available as Flush or Non-flush and cable or M12 plug versions.

Back part of the sensor



Yellow LED

- Output
- Short circuit
- Timer

Green LED

- Power
- Stability
- IO-Link communication

The Capacitive CA12CA/CA18CA/CA30CA IO-Link Family

	M12/M18/M30 DC IO-Link 4 TH Generation TRIPLESIELD™					
	M12		M18		M30	
Connection	Flush	Non-Flush	Flush	Non-Flush	Flush	Non-Flush
Cable	CA12CAF04BPA2IO	CA12CAN08BPA2IO	CA18CAF08BPA2IO	CA18CAN12BPA2IO	CA30CAF16BPA2IO	CA30CAN25BPA2IO
Plug	CA12CAF04BPM1IO	CA12CAN08BPM1IO	CA18CAF08BPM1IO	CA18CAN12BPM1IO	CA30CAF16BPM1IO	CA30CAN25BPM1IO
Sensing distance	0 - 4 mm	0 - 8 mm	0 - 8 mm	0 - 12 mm	0 - 16 mm	0 - 25 mm
Adjustable distance	0.5 - 4 mm	0.5 - 8 mm	2 - 10 mm	3 - 15 mm	2 - 20 mm	4 - 30 mm
IO-Link	Transmission type: COM2 (38.4 k Baud), Revision: 1.1, SDCI standard: IEC 61131-9, Profiles: Smart sensor (Process Data Variable; Device Identification), SIO mode: Yes, Required master part type: A, Min. process cycle time [ms]: 5					
Selectable function output 1	NPN, PNP or Push-Pull					
Selectable function output 2	NPN, PNP, Push-Pull, External input or External teach					
Diagnostic	Operating hours, Power cycles, Detection cycles, max. and min. Temperatures, Short-circuit, Maintenance, No of Parameter changes.					
Logic functions	AND, OR, X-OR, Gated SR-FF					
Timer functions	ON Delay, OFF delay, ON+OFF delay and One shot					
Sensitivity control	Teach-button, Teach by wire or by IO-Link		Trimmer input, Teach by wire or by IO-Link			
Rated operational voltage (U _r)	10 to 40 V DC (ripple included)					
No load supply current (I _s)	≤ 20 mA					
Minimum operational current (I _m)	≤ 0.5 mA					
Off-State current (I _o)	≤ 100 µA					
Voltage drop, digital (U _d)	≤ 1.0 V DC @ 200 mA DC					
Capacitive load	100 nF @ 200 mA					
Frequency of operating cycles (f)	Standard mode: < 15 Hz High speed mode: < 50 Hz		< 50 Hz			
Response time t _{ON} / t _{OFF}	Standard mode: < 26 ms / 37 ms High speed mode CAF: < 10 ms / 10 ms High speed mode CAN: < 9 ms / 11 ms		< 10 ms			
Power on delay (t _i)	≤ 300 ms					
Hysteresis (adjustable)	4%	6%	6%	15%	7%	10%
Led indications	Yellow LED steady: Output ON and signal stability. Yellow LED flashing: Output short-circuit, timer indication and teach. Green LED steady: Power ON and signal stability. Green LED flashing: IO-Link mode. Green and Yellow LEDs flashing: Find my sensor (only CA12..).					
Sensor protection	Shortcircuit (A), reverse polarity (B) and transients (C)					
Electrostatic discharge	Contact discharge: > 30 kV. Air discharge: > 30 kV (IEC 61000-4-2)		Contact discharge: > 40 kV. Air discharge: > 40 kV (IEC 61000-4-2)			
Electrical fast transients/burst	±4kV/5kHz (IEC 61000-4-4; EN 60947-1)					
Wire conducted disturbances	> 10 Vrms (IEC 61000-4-6)		> 20 Vrms (IEC 61000-4-6)			
Power - frequency magnetic fields	Continuous: > 60 A/m, 75.9 µ tesla. Short-time: > 600 A/m, 759 µ tesla (IEC 61000-4-8)					
Radiated RF electromagnetic fields	> 15 V/m (IEC 61000-4-3)		> 20 V/m (IEC 61000-4-3)			
Vibration	10 to 150 Hz, 1 mm/15G in X,Y and Z direction (EN 60068-2-6)					
Shock	30G/11 ms. 3 positive and 3 negative in X,Y and Z direction (EN 60068-2-27)					
Drop test	2 times from 1m, 100 times from 0,5m (EN 60068-2-31)					
Degree of protection	IP 67, IP 68 (EN 60529; EN 60947-1)		IP 67, IP 68, IP 69K (EN 60529; EN 60947-1; DIN 40050-9)			
NEMA type	1, 2, 12 (NEMA 250)		1, 2, 4, 4X, 5, 6, 6P, 12 (NEMA 250)			
Ambient temperature	Operating: -30 to +85°C (-22 to +185°F). Storage: -40 to +85°C (-40 to +185°F)					
Max. temperature on sensing face	-		120°C (248°F)			
CE marking	According to EN 60947-5-2					
Approvals	cULus (UL508)		cULus (UL508), ECOLAB			
Overvoltage category	III (IEC60664; EN 60947-1)					
Pollution degree	3(IEC60664/60664A; EN 60947-1)					
MTTF ₂	161.1 years @ 40°C (104°F)		114.6 years @ 40°C (104°F)		98.3 years @ 40°C (104°F)	
Material	Body front: 30% glass reinforced PBT. Body back: PBT. Teach-button: TPE. Back part: Polyester, softened, black.		Body: PBT grey, 30% glass reinforced. Trimmer shaft: Nylon, blue. Back part: Grilamid TR55, black.			
Tightening torque	≤ 1.8 Nm		≤ 2.6 Nm		≤ 7.5 Nm	
Cable	PVC, black, 2 m, 4 x 0.14 mm ² , Ø=3.3 mm, Oil proof		PVC, grey, 2 m, 4 x 0.34 mm ² , Ø=5.2 mm, Oil proof			
Connector	M12, 4-pin					
Dimensions	Cable: M12 x 78 mm, Plug: M12 x 80 mm		Cable and Plug: M18 x 70 mm		Cable and Plug: M30 x 61 mm	
Weight incl. packaging	Cable version ≤ 100 g, Plug version ≤ 55 g		Cable version ≤ 150 g, Plug version ≤ 75 g		Cable version ≤ 190 g, Plug version ≤ 106 g	
Accessories, additional	Connectors: CONE14NF...-series. Mounting brackets: AMB12-A... and AMB12-S...		Connectors: CONB14NF...-series. Mounting brackets: AMB18-A... and AMB18-S...		Connectors: CONB14NF...-series. Mounting brackets: AMB30-A... and AMB30-S...	
Additional Information	www.gavazziautomation.com					

CA12/18/30 series

IO-Link sensors in stainless steel housing

Features and functions

CA12EAF.IO Flush



CA12EAN.IO Non-flush



All versions are available as Flush or Non-flush and cable or M12 plug versions.

Top part of the sensor

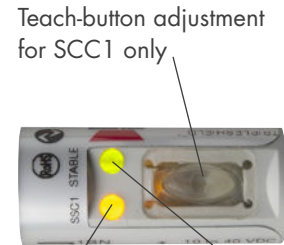

Yellow LED

- Output
- Short circuit
- Timer
- Find my sensor

Green LED

- Power
- Stability
- IO-Link communication
- Find my sensor

CA18EAF.IO Flush



CA18EAN.IO Non-Flush



All versions are available as Flush or Non-flush and cable or M12 plug versions.

Back part of the sensor

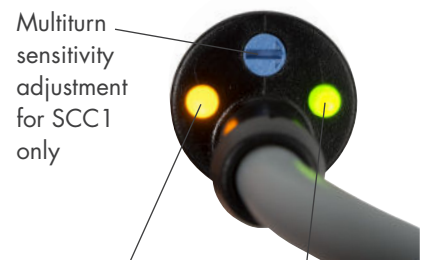

Yellow LED

- Output
- Short circuit
- Timer
- Find my sensor

Green LED

- Power
- Stability
- IO-Link communication
- Find my sensor

CA30EAF.IO Flush



CA30EAN.IO Non-Flush



All versions are available as Flush or Non-flush and cable or M12 plug versions.

Back part of the sensor



Yellow LED

- Output
- Short circuit
- Timer
- Find my sensor

Green LED

- Power
- Stability
- IO-Link communication
- Find my sensor

The Capacitive CA12EA/CA18EA/CA30EA IO-Link Family

	M12 / M18 / M30 DC IO-Link 4 TH Generation TRIPLESIELD™					
	M12		M18		M30	
Connection	Flush	Non-Flush	Flush	Non-Flush	Flush	Non-Flush
Cable	CA12EAF04BPA2IO	CA12EAN08BPA2IO	CA18EAF08BPA2IO	CA18EAN12BPA2IO	CA30EAF16BPA2IO	CA30EAN25BPA2IO
Plug	CA12EAF04BPM1IO	CA12EAN08BPM1IO	CA18EAF08BPM1IO	CA18EAN12BPM1IO	CA30EAF16BPM1IO	CA30EAN25BPM1IO
Sensing distance	0 - 4 mm	0 - 8 mm	0 - 8 mm	0 - 12 mm	0 - 16 mm	0 - 25 mm
Adjustable distance	0.5 - 4 mm	0.5 - 8 mm	2 - 10 mm	3 - 15 mm	2 - 20 mm	4 - 30 mm
IO-Link	Transmission type: COM2 (38.4 k Baud), Revision: 1.1, SDCI standard: IEC 61131-9, Profiles: Smart sensor (Process Data Variable; Device Identification), SIO mode: Yes, Required master port type: A, Min. process cycle time [ms]: 5					
Selectable function output 1	NPN, PNP or Push-Pull					
Selectable function output 2	NPN, PNP, Push-Pull, External input or External teach					
Diagnostic	Operating hours, Power cycles, Detection cycles, max. and min. Temperatures, Short-circuit, Maintenance, No of Parameter changes.					
Logic functions	AND, OR, X-OR, Gated SR-FF					
Timer functions	ON Delay, OFF delay, ON+OFF delay and One shot					
Sensitivity control	Teach-button, Teach by wire or by IO-Link		Trimmer input, Teach by wire or by IO-Link			
Rated operational voltage (U _r)	10 to 40 V DC (ripple included)					
No load supply current (I ₀)	≤ 20 mA					
Minimum operational current (I _m)	≤ 0.5 mA					
Off-State current (I _s)	≤ 100 μA					
Voltage drop, digital (U _d)	≤ 1.0 V DC @ 200 mA DC					
Capacitive load	100 nF @ 200 mA					
Frequency of operating cycles (f)	Standard mode: < 15 Hz High speed mode: < 50 Hz		50 Hz			
Response time t _{ON} / t _{OFF}	Standard mode: < 26 ms / 39 ms High speed mode EAF: < 10 ms / 10 ms High speed mode EAN: < 8 ms / 12 ms		10 ms			
Power on delay (t _i)	300 ms					
Hysteresis (adjustable)	6%	6%	14%	15%	8%	10%
Led indications	Yellow LED steady: Output ON and signal stability. Yellow LED flashing: Output short-circuit, timer indication and teach. Green LED steady: Power ON and signal stability. Green LED flashing: IO-Link mode. Green and Yellow LEDs flashing: Find my sensor (only CA12..).					
Sensor protection	Shortcircuit (A), reverse polarity (B) and transients (C)					
Electrostatic discharge	Contact discharge: > 30 kV. Air discharge: > 30 kV (IEC 61000-4-2)		Contact discharge: > 40 kV. Air discharge: > 40 kV (IEC 61000-4-2)			
Electrical fast transients/burst	±4kV/5kHz (IEC 61000-4-4; EN 60947-1)					
Wire conducted disturbances	> 10 Vrms (IEC 61000-4-6)		> 20 Vrms (IEC 61000-4-6)			
Power - frequency magnetic fields	Continuous: > 60 A/m, 75.9 μ tesla. Short-time: > 600 A/m, 759 μ tesla (IEC 61000-4-8)					
Radiated RF electromagnetic fields	> 15 V/m (IEC 61000-4-3)		> 20 V/m (IEC 61000-4-3)			
Vibration	10 to 150 Hz, 1 mm/15G in X,Y and Z direction (EN 60068-2-6)					
Shock	30G/11 ms. 3 positive and 3 negative in X,Y and Z direction (EN 60068-2-27)					
Drop test	2 times from 1m, 100 times from 0,5m (EN 60068-2-31)					
Degree of protection	IP 67, IP 68 (EN 60529; EN 60947-1)		IP 67, IP 68, IP 69K (EN 60529; EN 60947-1; DIN 40050-9)			
NEMA type	1, 2, 12 (NEMA 250)		1, 2, 4, 4X, 5, 6, 6P, 12 (NEMA 250)			
Ambient temperature	Operating: -30 to +85°C (-22 to +185°F). Storage: -40 to +85°C (-40 to +185°F)					
Max. temperature on sensing face	-		120°C (248°F)			
CE marking	According to EN 60947-5-2					
Approvals	cULus (UL508)		cULus (UL508), ECOLAB			
Overvoltage category	III (IEC60664; EN 60947-1)					
Pollution degree	3(IEC60664/60664A; EN 60947-1)					
MTTF ₂	161.1 years @ 40°C (104°F)		114.6 years @ 40°C (104°F)		98.3 years @ 40°C (104°F)	
Material	Body front: Stainless steel AISI316L. Body back: PBT. Teach-button: TPE. Back part: Polyester, softened, black.		Body: Stainless steel AISI316L. Front: PBT white, 30% glass reinforced. Trimmer shaft: Nylon, blue. Back part: Grilamid TR55, black.			
Tightening torque	≤ 17.5 Nm		≤ 25 Nm		≤ 30 Nm	
Cable	PVC, black, 2 m, 4 x 0.14 mm ² , Ø=3.3 mm, Oil proof		PVC, grey, 2 m, 4 x 0.34 mm ² , Ø=5.2 mm, Oil proof			
Connector	M12, 4-pin					
Dimensions	Cable: M12 x 78 mm, Plug: M12 x 80 mm		Cable and Plug: M18 x 70 mm		Cable and Plug: M30 x 61 mm	
Weight incl. packaging	Cable version ≤ 105 g, Plug version ≤ 60 g		Cable version ≤ 170 g, Plug version ≤ 95 g		Cable version ≤ 250 g, Plug version ≤ 175 g	
Accessories, additional	Connectors: CONE14NF...-series. Mounting brackets: AMB12-A... and AMB12-S...		Connectors: CONB14NF...-series. Mounting brackets: AMB18-A... and AMB18-S...		Connectors: CONB14NF...-series. Mounting brackets: AMB30-A... and AMB30-S...	
Additional Information	www.gavazziautomation.com					

CA12/18/30 series

IO-Link sensors in PEEK or PTFE housing

Features and functions

CA12KAF08BPM1IO Non-flush

M12 plug



CA12KAF08BPA2IO Non-flush

Cable



All versions are available as Non-flush and cable or M12 plug versions.

Top part of the sensor

Teach-button adjustment for SCC1 only

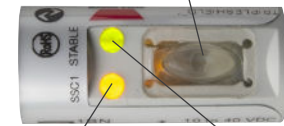

Yellow LED

- Output
- Short circuit
- Timer
- Find my sensor

Green LED

- Power
- Stability
- IO-Link communication
- Find my sensor

CA18FAF..IO Flush

M12 plug



120°C on sensing face

CA18FAN..IO Non-Flush

Cable



All versions are available as Flush or Non-flush and cable or M12 plug versions.

Back part of the sensor

Multiturn sensitivity adjustment for SCC1 only

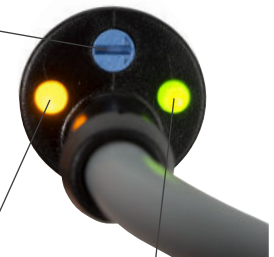

Yellow LED

- Output
- Short circuit
- Timer
- Find my sensor

Green LED

- Power
- Stability
- IO-Link communication
- Find my sensor

CA30FAF..IO Flush

M12 plug



120°C on sensing face

CA30FAN..IO Non-Flush

Cable



All versions are available as Flush or Non-flush and cable or M12 plug versions.

Back part of the sensor

Multiturn sensitivity adjustment for SCC1 only



Yellow LED

- Output
- Short circuit
- Timer
- Find my sensor

Green LED

- Power
- Stability
- IO-Link communication
- Find my sensor

The Capacitive CA12KA/CA18FA/CA30FA IO-Link Family

	M12/M18/M30 DC IO-Link 4 TH Generation TRIPLESIELD™					
	M12		M18		M30	
Connection	Non-Flush		Flush	Non-Flush	Flush	Non-Flush
Cable	CA12KAN08BPA2IO		CA18FAF08BPA2IO	CA18FAN12BPA2IO	CA30FAF16BPA2IO	CA30FAN25BPA2IO
Plug	CA12KAN08BPM1IO		CA18FAF08BPM1IO	CA18FAN12BPM1IO	CA30FAF16BPM1IO	CA30FAN25BPM1IO
Sensing distance	0 - 8 mm		0 - 8 mm	0 - 12 mm	0 - 16 mm	0 - 25 mm
Adjustable distance	0.5 - 8 mm		2 - 10 mm	3 - 15 mm	2 - 20 mm	4 - 30 mm
IO-Link	Transmission type: COM2 (38.4 k Baud), Revision: 1.1, SDCI standard: IEC 61131-9, Profiles: Smart sensor (Process Data Variable; Device Identification), SIO mode: Yes, Required master part type: A, Min. process cycle time [ms]: 5					
Selectable function output 1	NPN, PNP or Push-Pull					
Selectable function output 2	NPN, PNP, Push-Pull, External input or External teach					
Diagnostic	Operating hours, Power cycles, Detection cycles, max. and min. Temperatures, Short-circuit, Maintenance, No of Parameter changes.					
Logic functions	AND, OR, X-OR, Gated SR-FF					
Timer functions	ON Delay, OFF delay, ON+OFF delay and One shot					
Sensitivity control	Teach-button, Teach by wire or by IO-Link		Trimmer input, Teach by wire or by IO-Link			
Rated operational voltage (U _e)	10 to 40 VDC (ripple included)					
No load supply current (I _s)	≤ 20 mA					
Minimum operational current (I _m)	≤ 0.5 mA					
Off-State current (I _s)	≤ 100 µA					
Voltage drop, digital (U _d)	≤ 1.0 VDC @ 200 mA DC					
Capacitive load	100 nF @ 200 mA					
Frequency of operating cycles (f)	Standard mode: < 15 Hz High speed mode: < 50 Hz		< 50 Hz			
Response time t _{ON} / t _{OFF}	Standard mode: < 26 ms / 37 ms High speed mode: < 9 ms / 11 ms		< 10 ms			
Power on delay (t _i)	≤ 300 ms					
Hysteresis (adjustable)	6%		4%	15%	5%	10%
Led indications	Yellow LED steady: Output ON and signal stability. Yellow LED flashing: Output short-circuit, timer indication and teach. Green LED steady: Power ON and signal stability. Green LED flashing: IO-Link mode. Green and Yellow LEDs flashing: Find my sensor (only CA12..).					
Sensor protection	Shortcircuit (A), reverse polarity (B) and transients (C)					
Electrostatic discharge	Contact discharge: > 30 kV. Air discharge: > 30 kV (IEC 61000-4-2)		Contact discharge: > 40 kV. Air discharge: > 40 kV (IEC 61000-4-2)			
Electrical fast transients/burst	±4kV/5kHz (IEC 61000-4-4; EN 60947-1)					
Wire conducted disturbances	> 10 Vrms (IEC 61000-4-6)		> 20 Vrms (IEC 61000-4-6)			
Power - frequency magnetic fields	Continuous: > 60 A/m, 75.9 µ tesla. Short-time: > 600 A/m, 759 µ tesla (IEC 61000-4-8)					
Radiated RF electromagnetic fields	> 15 V/m (IEC 61000-4-3)		> 20 V/m (IEC 61000-4-3)			
Vibration	10 to 150 Hz, 1 mm/15G in X,Y and Z direction (EN 60068-2-6)					
Shock	30G /11 mS. 3 positive and 3 negative in X,Y and Z direction (EN 60068-2-27)					
Drop test	2 times from 1m, 100 times from 0,5m (EN 60068-2-31)					
Degree of protection	IP 67, IP 68 (EN 60529; EN 60947-1)		IP 67, IP 68, IP 69K (EN 60529; EN 60947-1; DIN 40050-9)			
NEMA type	1, 2, 12 (NEMA 250)		1, 2, 4, 4X, 5, 6, 6P, 12 (NEMA 250)			
Ambient temperature	Operating: -30 to +85°C (-22 to +185°F). Storage: -40 to +85°C (-40 to +185°F)					
Max. temperature on sensing face	-		120°C (248°F)			
CE marking	According to EN 60947-5-2					
Approvals	cULus (UL508)		cULus (UL508), ECOLAB			
Overvoltage category	III (IEC60664; EN 60947-1)					
Pollution degree	3(IEC60664/60664A; EN 60947-1)					
MTTF ₂	161.1 years @ 40°C (104°F)		114.6 years @ 40°C (104°F)		98.3 years @ 40°C (104°F)	
Material	Body front: PEEK. Body back: PBT. Teach-button: TPE. Back part: Polyester, softened, black.		Body: PTFE. Trimmer shaft: Nylon, blue. Back part: Grilamid TR55, black.			
Tightening torque	≤ 1.8 Nm		≤ 2.6 Nm		≤ 7.5 Nm	
Cable	PVC, black, 2 m, 4 x 0.14 mm ² , Ø=3.3 mm, Oil proof		PVC, grey, 2 m, 4 x 0.34 mm ² , Ø=5.2 mm, Oil proof			
Connector	M12, 4-pin					
Dimensions	Cable: M12 x 78 mm, Plug: M12 x 80 mm		Cable and Plug: M18 x 70 mm		Cable and Plug: M30 x 61 mm	
Weight incl. packaging	Cable version ≤ 100 g, Plug version ≤ 55 g		Cable version ≤ 150 g, Plug version ≤ 75 g		Cable version ≤ 190 g, Plug version ≤ 106 g	
Accessories, additional	Connectors: CONE14NF...-series. Mounting brackets: AMB12-A... and AMB12-S...		Connectors: CONB14NF...W-series. Mounting brackets: AMB18-A... and AMB18-S...		Connectors: CONB14NF...W-series. Mounting brackets: AMB30-A... and AMB30-S...	
Additional Information	www.gavazziautomation.com					

OUR SALES NETWORK IN EUROPE

AUSTRIA

Carlo Gavazzi GmbH
Ketzerergasse 374,
A-1230 Wien
Tel: +43 1 888 4112
Fax: +43 1 889 1053
office@carlogavazzi.at

BELGIUM

Carlo Gavazzi NV/SA
Mechelsesteenweg 311,
B-1800 Vilvoorde
Tel: +32 2 257 41 20
sales@carlogavazzi.be

DENMARK

Carlo Gavazzi Handel A/S
Over Hadstensevej 40,
DK-8370 Hadsten
Tel: +45 89 60 61 00
Fax: +45 86 98 15 30
handel@gavazzi.dk

FINLAND

Carlo Gavazzi OY AB
Ahventie, 4 B
FI-02170 Espoo
Tel: +358 9 756 2000
myynti@gavazzi.fi

FRANCE

Carlo Gavazzi Sarl
Zac de Paris Nord II, 69, rue de la Belle Etoile,
F-95956 Roissy CDG Cedex
Tel: +33 1 49 38 98 60
Fax: +33 1 48 63 27 43
french.team@carlogavazzi.fr

GERMANY

Carlo Gavazzi GmbH
Pfnorstr. 10-14
D-64293 Darmstadt
Tel: +49 6151 81 00 0
Fax: +49 6151 81 00 40
info@gavazzi.de

GREAT BRITAIN

Carlo Gavazzi UK Ltd
4.4 Frimley Business Park,
Frimley, Camberley, Surrey GU16 7SG
Tel: +44 1 276 854110
Fax: +44 1 276 682140
sales@carlogavazzi.co.uk

ITALY

Carlo Gavazzi SpA
Via Milano 13,
I-20045 Lainate
Tel: +39 02 931 76 1
info@gavazziacbu.it

NETHERLANDS

Carlo Gavazzi BV
Wijkermeerweg 23,
NL-1948 NT Beverwijk
Tel: +31 251 22 93 45
info@carlogavazzi.nl

NORWAY

Carlo Gavazzi AS
Melkeveien 13,
N-3919 Porsgrunn
Tel: +47 35 93 08 00
Fax: +47 35 93 08 01
posti@gavazzi.no

PORTUGAL

Carlo Gavazzi Lda
Rua dos Jerónimos 38-B,
P-1400-212 Lisboa
Tel: +351 21 361 70 60
Fax: +351 21 362 13 73
carlogavazzi@carlogavazzi.pt

SPAIN

Carlo Gavazzi SA
Avda. Iparraguirre, 80-82,
E-48940 Leioa (Bizkaia)
Tel: +34 94 480 40 37
Fax: +34 94 431 60 81
gavazzi@gavazzi.es

SWEDEN

Carlo Gavazzi AB
V:a Kyrkogatan 1,
S-652 24 Karlstad
Tel: +46 54 85 11 25
Fax: +46 54 85 11 77
info@carlogavazzi.se

SWITZERLAND

Carlo Gavazzi AG
Verkauf Schweiz/Vente Suisse
Sumpfstrasse 3,
CH-6312 Steinhausen
Tel: +41 41 747 45 35
Fax: +41 41 740 45 40
info@carlogavazzi.ch

OUR SALES NETWORK IN THE AMERICAS

USA

Carlo Gavazzi Inc.
750 Hastings Lane,
Buffalo Grove, IL 60089-6904, USA
Tel: +1 847 465 61 00
sales@carlogavazzi.com

CANADA

Carlo Gavazzi Inc.
2430 Meadowpine Blvd Unit 104,
Mississauga, ON L5N 6S2, Canada
Tel: +1 905 542 0979
gavazzi@carlogavazzi.com

MEXICO

Carlo Gavazzi Mexico S.A. de C.V.
Circuito Puericultores 22, Ciudad Satelite
Naucalpan de Juarez, Edo Mex. CP 53100
Mexico
T +52 55 5373 7042
F +52 55 5373 7042
mexicosales@carlogavazzi.com

BRAZIL

Carlo Gavazzi Automação Ltda.
Av. Francisco Matarazzo, 1752
Conj 2108 - CEP 05001-200 -
São Paulo - SP - Brazil
Tel: +55 11 3052 0832
Fax: +55 11 3057 1753
info@carlogavazzi.com.br

OUR SALES NETWORK IN ASIA AND PACIFIC

SINGAPORE

Carlo Gavazzi Automation Singapore Pte. Ltd.
61 Tai Seng Avenue #05-06
Print Media Hub @ Paya Lebar iPark
Singapore 534167
Tel: +65 67 466 990
Fax: +65 67 461 980
info@carlogavazzi.com.sg

MALAYSIA

Carlo Gavazzi Automation (M) SDN. BHD.
D12-06-G, Block D12,
Pusat Perdagangan Dana 1,
Jalan PJU 1A/46, 47301 Petaling Jaya,
Selangor, Malaysia.
Tel: +60 3 7842 7299
Fax: +60 3 7842 7399
sales@gavazzi-asia.com

CHINA

Carlo Gavazzi Automation
(China) Co. Ltd.
Unit 2308, 23/F.,
News Building, Block 1, 1002
Middle Shennan Zhong Road,
Futian District,
Shenzhen, China
Tel: +86 755 8369 9500
Fax: +86 755 8369 9300
sales@carlogavazzi.cn

HONG KONG

Carlo Gavazzi Automation
Hong Kong Ltd.
Unit No. 16 on 25th Floor, One Midtown,
No. 11 Hoi Shing Road, Tsuen Wan,
New Territories, Hong Kong
Tel: +852 26261332
Fax: +852 26261316

TAIWAN

Branch of Carlo Gavazzi Automation
Singapore Pte. Ltd.
12F-3, No. 530, Yingcai Rd.,
West Dist., Taichung City 403518,
Taiwan, China
Tel: +886 4 2258 4001
Fax: +886 4 2258 4002

OUR COMPETENCE CENTRES AND PRODUCTION SITES

DENMARK

Carlo Gavazzi Industri A/S
Hadsten

MALTA

Carlo Gavazzi Ltd
Zejtun

ITALY

Carlo Gavazzi Controls SpA
Belluno

LITHUANIA

Uab Carlo Gavazzi Industri Kaunas
Kaunas

CHINA

Carlo Gavazzi Automation (Kunshan) Co., Ltd.
Kunshan

HEADQUARTERS

Carlo Gavazzi Automation SpA
Via Milano, 13
I-20045 - Lainate (MI) - ITALY
Tel: +39 02 931 76 1
info@gavazziautomation.com

Energy to Components!

www.gavazziautomation.com